

Oil Solutions

Phone 0421 336 009

Fax 03 9012 4332

sales@oilsolutions.com.au

www.oilsolutions.com.au

Low Pressure Filter

Pi 230

Operating pressure 25/40 bar, Nominal size up to 800

1.Features

Efficient filters for modern hydraulic systems

- Modular design principle
- Compact design
- Minimal pressure drop
- Optical/electrical/electronic differential contamination control
- 3" SAE-bolt flange connection (DN 76)
- Inlet sideways or at the bottom, outlet sideways

Quality filters, easy to service

- Equipped with highly efficient Sm-x- or Sm-N 2-filter elements
- Optional with metallic support parts or a high differential pressure stability or with fully ashable and disposable MAHLE CC-elements
- ®-valued elements per ISO 16889
- High dirt holding capacity and differential pressure stability providing optimal element service life
- Maintainable with toggle-lock for easy element change

Worldwide distribution



2. Flow rates/pressure drop curve complete filter

■ 190 mm²/s (25° E)
■ 33 mm²/s (4,5° E)

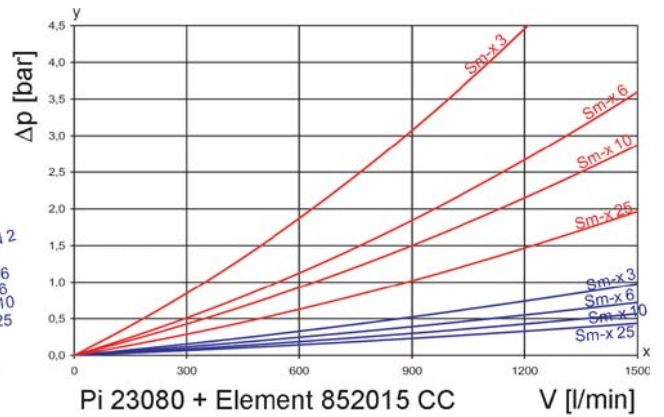
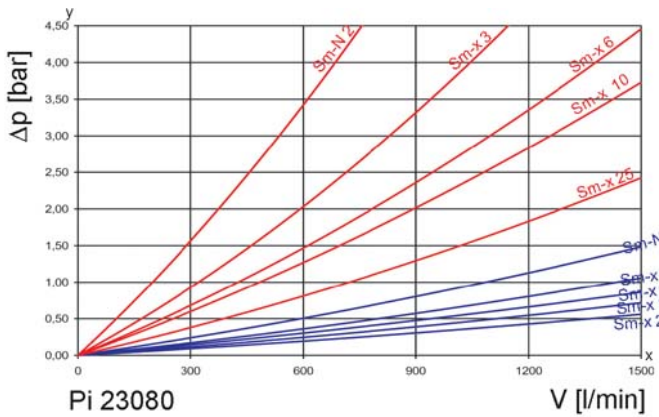
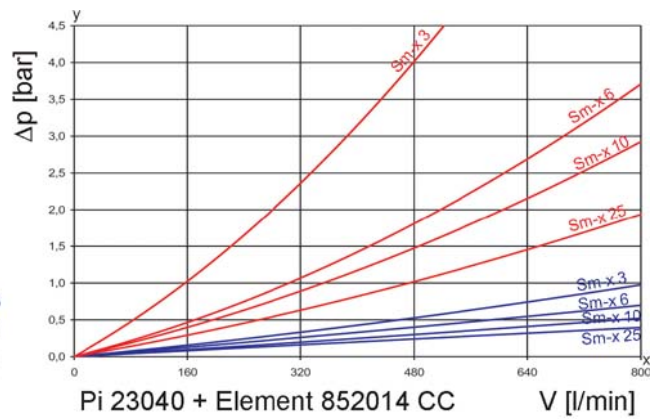
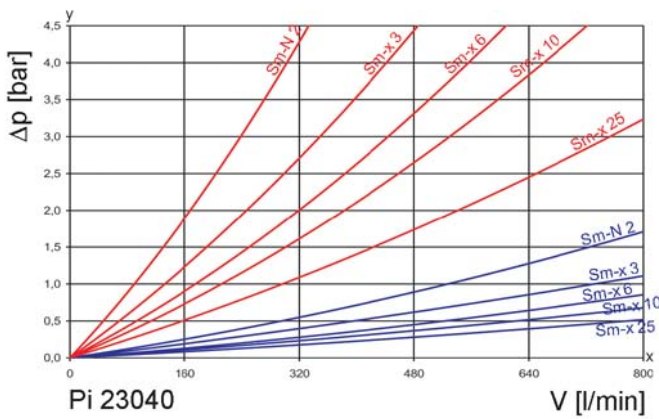

y = differential pressure Δp [bar]
 x = flow rate V [l/min]

3. Separation characteristics

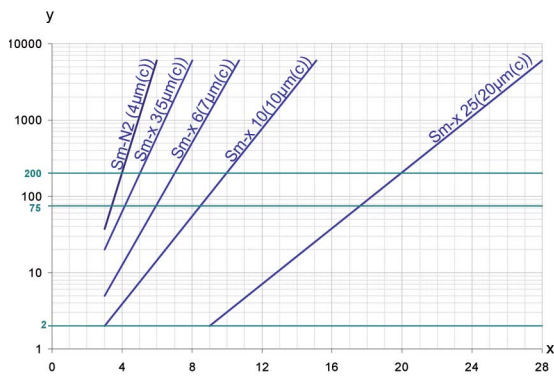

y = beta-ratio
x = particle size [µm]

determined by multipass tests (ISO 16889)
calibration according to ISO 11171 (NIST)

4. Filter performance data

measured according to ISO 16889 (multipass test)

Sm-x elements with
Δ p 20 bar

Sm-x	3	$\beta_{5(C)} \geq 200$
Sm-x	6	$\beta_{7(C)} \geq 200$
Sm-x	10	$\beta_{10(C)} \geq 200$
Sm-x	16	$\beta_{15(C)} \geq 200$
Sm-x	25	$\beta_{20(C)} \geq 200$

up to 10 bar differential
pressure

Sm-x vst elements with
Δ p 5 bar

Sm-x vst	3	$\beta_{5(C)} \geq 200$
Sm-x vst	6	$\beta_{7(C)} \geq 200$
Sm-x vst	10	$\beta_{10(C)} \geq 200$
Sm-x vst	16	$\beta_{15(C)} \geq 200$
Sm-x vst	25	$\beta_{20(C)} \geq 200$

up to 5 bar differential
pressure

5. Quality assurance

MAHLE filter and filter elements are manufactured respectively, tested in accordance with the following international standards:

Norm	Designation
DIN ISO 2941	Hydraulic fluid power filter elements; verification of collapse/burst resistance
DIN ISO 2942	Hydraulic fluid power filter elements; verification of fabrication integrity
DIN ISO 2943	Hydraulic fluid power filter elements; verification of material compatibility with fluids
DIN ISO 3723	Hydraulic fluid power filter elements; method for end load test
DIN ISO 3724	Hydraulic fluid power elements; verification of flow fatigue characteristics
ISO 3968	Hydraulic fluid power filters; evaluation of pressure drop versus flow characteristics
ISO 10771.1	Fatigue pressure testing of metal containing envelopes in hydraulic fluid applications
ISO 16889	Hydraulic fluid power filters; multipass method for evaluation filtration performance of a filter element

6. Symbols

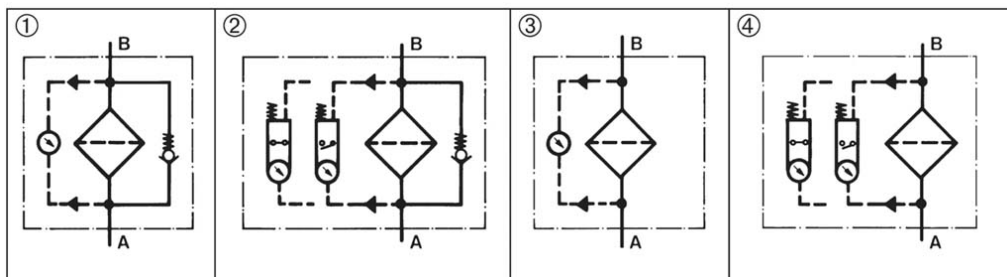

7. Order numbers

Example for ordering filters:

1. Housing design	2. Filter element
Nominal size: 400, with bypass, electrical contamination indicator, inlet at the side for standard filter elements Type: Pi 23040 / 22-058 Order number: 76320972	SM-x 10 Type: Pi 852014 SM-x 10 Order number: 76321814

7.1 Housing design standard

Nominal size NG [l/min]	Order number inlet at the bottom	Type inlet at the bottom	Order number inlet at the side	Type inlet at the side	①	②	③	④
					with bypass valve and optical indicator	with bypass valve and electrical indicator	with optical indicator	with electrical indicator
400	76334668	Pi 23040/12-057	76320931	Pi 23040/22-057				
	76320964	Pi 23040/12-058	76320972	Pi 23040/22-058				
	76321004	Pi 23040/12-068	76321012	Pi 23040/22-068				
	76321046	Pi 23040/12-069	76321053	Pi 23040/22-069				
800	76320949	Pi 23080/12-057	76320956	Pi 23080/22-057				
	76320980	Pi 23080/12-058	76320998	Pi 23080/22-058				
	76321020	Pi 23080/12-068	76321038	Pi 23080/22-068				
	76321061	Pi 23080/12-069	76321079	Pi 23080/22-069				

7.2 Filter elements standard*

Nominal size NG [l/min]	Order number	Type	Filter material	Collapse pressure [bar]	Filter surface [cm ²]
400	76136220	852014 Sm-N 2	Sm-N 2	20	18533
	76321830	852014 Sm-x 3	Sm-x 3		24830
	76321822	852014 Sm-x 6	Sm-x 6		24830
	76321814	852014 Sm-x 10	Sm-x 10		24830
	76321806	852014 Sm-x 25	Sm-x 25		24830
800	76326212	852015 Sm-N 2	Sm-N 2	20	42275
	76321897	852015 Sm-x 3	Sm-x 3		57200
	76321889	852015 Sm-x 6	Sm-x 6		57200
	76321871	852015 Sm-x 10	Sm-x 10		57200
	76321863	852015 Sm-x 25	Sm-x 25		57200

* further elements available upon request.

7.3 Housing design CC

Nominal size NG [l/min]	Order number inlet at the bottom	Type inlet at the bottom	Order number inlet at the side	Type inlet at the side	①	②	③	④
					with bypass valve and optical indicator	with bypass valve and electrical indicator	with optical indicator	with electrical indicator
400	79770074	Pi 23040/1C-057	79970116	Pi 23040/2C-057				
	76320642	Pi 23040/1C-058	76320659	Pi 23040/2C-058				
	76320683	Pi 23040/1C-068	76320691	Pi 23040/2C-068				
	76320725	Pi 23040/1C-069	76320733	Pi 23040/2C-069				
800	79768854	Pi 23080/1C-057	79768862	Pi 23080/2C-057				
	76320667	Pi 23080/1C-058	76320675	Pi 23080/2C-058				
	76320709	Pi 23080/1C-068	76320717	Pi 23080/2C-068				
	76320741	Pi 23080/1C-069	76320758	Pi 23080/2C-069				

7.4 Filter elements CC*

Nominal size NG [l/min]	Order number	Type	Filter material	Collapse pressure [bar]	Filter surface [cm ²]
400	76135859	852014 CC Sm-x 3	Sm-x 3	5	23000
	76135867	852014 CC Sm-x 6	Sm-x 6		23000
	76135875	852014 CC Sm-x 10	Sm-x 10		23000
	76135883	852014 CC Sm-x 25	Sm-x 25		23000
800	76322028	852015 CC Sm-x 3	Sm-x 3	5	60159
	76322010	852015 CC Sm-x 6	Sm-x 6		60159
	76322002	852015 CC Sm-x 10	Sm-x 10		60159
	76321996	852015 CC Sm-x 25	Sm-x 25		60159

* further elements available upon request respectively acc. leaflet "Filter elements and retrofit kits Pi 230/Pi 2300".

When filter with non bypass configuration is selected the collapse pressure of the element may not be exceeded.

8. Specifications

Operating pressure (10 ⁷ LW):	25 bar
Operating pressure (static):	40 bar
Temperature range:	-10 °C to +120 °C (other temperature ranges on request)
Bypass opening pressure:	Δ 3.5 bar ± 10 %
Filter head and cap material:	GAL
Filter bowl material:	AL
Sealing material:	NBR
Activating pressure of optical/ electrical differential pressure in- dicator:	Δ p 2.2 bar ± 0.3 bar
Electrical data of contamination indicator:	
Maximum voltage:	250 V AC/200 V DC
Maximum current on contact.:	1 A
Inrush current:	70 W
Type of protection:	IP 65 when inserted and secured
Contact:	bistable
Cable connection:	M 20 x 1.5

The switching function can be changed by turning the electric upper part by 180° (normally closed contact or normally open contact). The state on delivery is normally closed contact.

The use of quenching circuits must be checked in the case of inductivity in the DC circuit. The contamination indicator data sheet contains further information and additional contamination versions.

We draw attention to the fact that all values indicated are average values which do not always occur in specific cases of application. Our products are continually being further developed. Values, dimensions and weights can change as a result of this. Our specialized department will be please to offer you advice.

When using filters in areas which are to be classified according to the EU Directive 94/4 EC (ATEX 95), we recommend prior discussion with us. The standard version can be used for liquids based on mineral oil (corresponding to fluids in Group2 of Directive Directive 97/23 EC Article 9). Please consult with us if using other media.

Subject to technical alteration without prior notice.

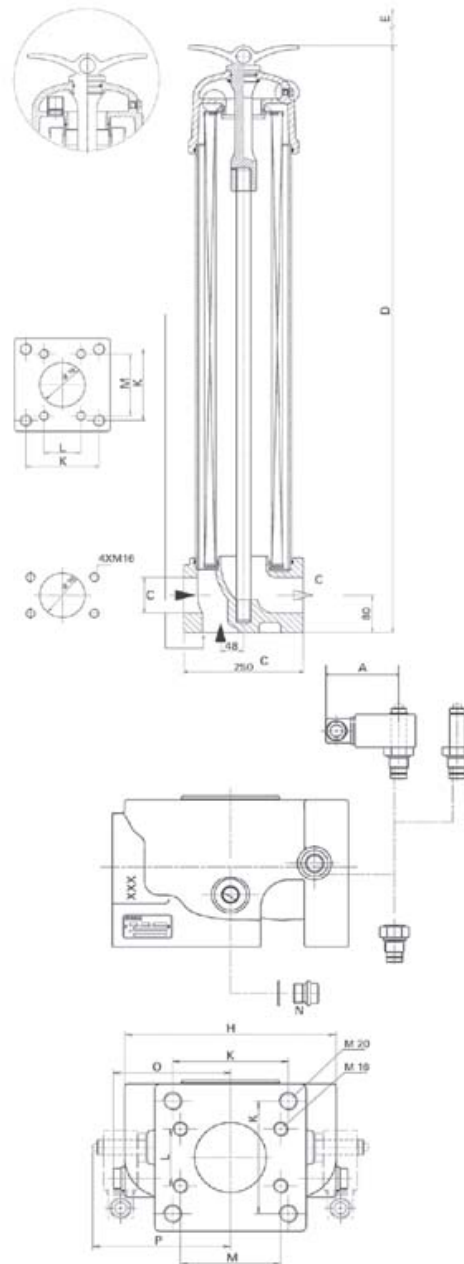

9. Dimensions

All dimensions except "C" and "N" in mm.

Type	A	B	C	D	E	F	G	H
Pi23040	78	80	SAE 3", 3000 psi	710	770	230	200	224
Pi23080	78	80	SAE 3", 3000 psi	1260	770	230	200	224

Type	I	K	L	M	N	O	P	Weight [kg]
Pi23040	250	122.3	61.9	106.6	G ½	124	146	29
Pi23080	250	122.3	61.9	106.6	G ½	124	146	38

10. Installation, operating and maintenance instructions

10.1 Filter installation

When installing filter make sure that sufficient space is available to remove spin-on cartridge.

10.2 Connecting the electrical contamination indicator

The electrical indicator is connected via a 2-pole appliance plug according to DIN EN 175301-803 with poles marked 1 and 2. The electrical section can be inverted to change from normally open to normally closed position or vice versa.

10.3 When must the filter be replaced?

- Filters equipped with optical and electrical contamination indicator: During cold starts, the indicator may give a warning signal. Depress the red button of the optical indicator once again and only after operating temperature has been reached. If the red button immediately pops out again and/or the electrical signal has not switched off after reaching operating temperature, the spin-on cartridge must be replaced after the end of the shift.
- Filters without contamination indicator: The filter element should be replaced after the trial run or flushing of the system. Afterwards follow the instructions of the manufacturer.
- Please always ensure that you have Original MAHLE replacement elements in stock: disposable elements Mic or Sm-x cannot be cleaned.

10.4. Element replacement

- Stop system and relieve filter from pressure.
- Loosen quick-action clamp, remove cover and open drain valve. Housing completely vented.
- Remove filter element from filter bowl.
- Check seals for damages. Replace, if necessary.
- Make sure that the part number on the spare element corresponds with the part number on the filter label. Open the plastic bag and push element over the spigot in the filter head. Now remove plastic bag.
- Close drain valve. Put the thumb screw together with the cover on the centre rod and tighten strong. Filter must be bled.

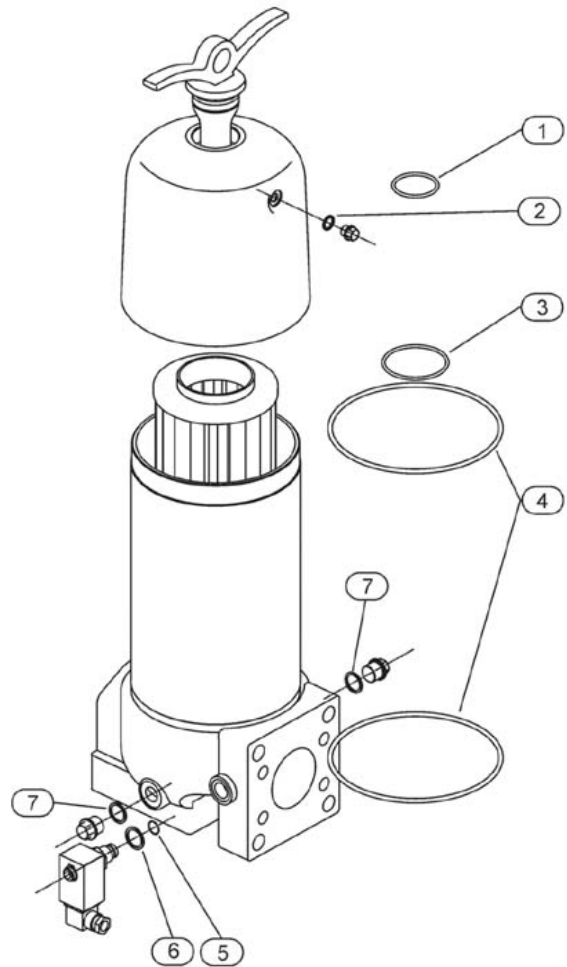

11. Spare parts list

Order numbers for spare parts		
Position	Type	Order number
①	Seal kit	
②	NBR	76321244
③	FPM	76321251
④	EPDM	76321269
	Differential pressure indicator	
	Optical PiS 3098/2,2	77669971
	Optical/electrical PiS 3097/2.2	77669948
⑤	Seal kit for differential pressure indicator	
	NBR	77760309
⑥	FPM	77760317
	EPDM	77760325

MAHLE

Industrial Filtration

MAHLE Filtersysteme GmbH
Industriefiltration
Schleifbachweg 45
D-74613 Öhringen
Phone +49 (0) 794/67-0
Fax +49 (0) 7941/67- 23429
industriefiltration@mahle.com
www.mahle-industriefiltration.com
76349484.11/2006