

# Oil Solutions



Pressure Gauges  
& Test Kits

Local solutions for  
individual customers  
worldwide

[www.oilsolutions.com.au](http://www.oilsolutions.com.au)    [sales@oilsolutions.com.au](mailto:sales@oilsolutions.com.au)

## Stauff Pressure Gauges

### SPG 63mm and 100mm

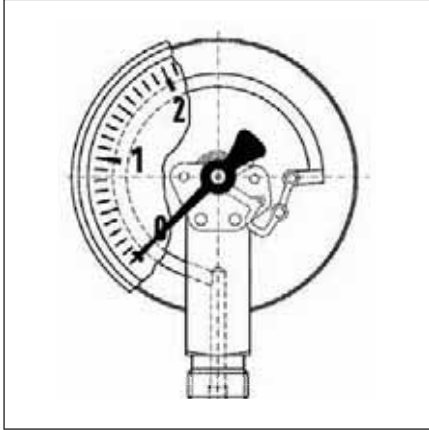

#### Application

For liquid media which is not highly viscous, do not crystallize and do not attack copper alloys.

For measurement in areas with high levels of vibration and high, dynamic pressure loads.

 When measuring gas or vapour, check for suitability and safety requirements in accordance with relevant Australian Standards.

**Type**  
SPG

**Nominal Size**  
63  
100

**Accuracy Class (EN 837-1/6)**  
1.6% of full scale 63 mm / 100 mm

**Ranges (EN 837-1/5)**  
-1/0 to -1/+15 bar  
0/0.6 to 0/1000 bar

**Application Area**  
Static load:  
 $\frac{3}{4}$  x full scale value  
Dynamic load:  
 $\frac{2}{3}$  x full scale value  
Short term:  
full scale value



SPG-63-SB



SPG-63-RB



SPG-100-SB



SPG-100-RB

#### Operating Temperature Range

Medium:  $T_{max} = +60^{\circ}\text{C}$   
Ambient:  $T_{max} = -20^{\circ}\text{C}$   
 $T_{max} = +60^{\circ}\text{C}$

#### Temperature Performance

Indication error when the temperature of the measuring element deviates from  $20^{\circ}\text{C}$ :  
rising temp. approx.  $\pm 0.4\%$  / 10K  
falling temp. approx.  $\pm 0.4\%$  / 10K  
percentage of full scale value.

#### Protection

IP 65 (EN 60529)  
with housing vent ( $\leq 25$  bar)  
IP 54

#### Standard Version

#### Connection

Brass, bottom or centre back  
63mm - G $\frac{1}{4}$  BSPP - spanner size 14  
100mm - G $\frac{1}{2}$  BSPP - spanner size 22  
(EN 837 - 1/7.3)

#### Measuring Element

Bourdon tube element, copper alloy  
 $\leq 60$  bar "C" Type bourdon tube  
 $> 60$  bar helical tube

#### Movement

Brass

#### Dial

Aluminium, white  
Dial marking black

#### Pointer

Aluminium, black

#### Housing

Stainless steel 1.4301  
with pressure relief port

#### Crimped Bezel

Stainless steel 1.4301

#### Front Glass

Plastic

#### Filling Liquid

Glycerine (99.5%)

#### Options (refer to page 4)

- Back flange 63mm / 100mm
- Clamp fixing
- 3-hole fixing, panel mounting bezel 63mm / 100mm
- Special scales on request refer to page 5

## Dimensions

### SPG 63mm

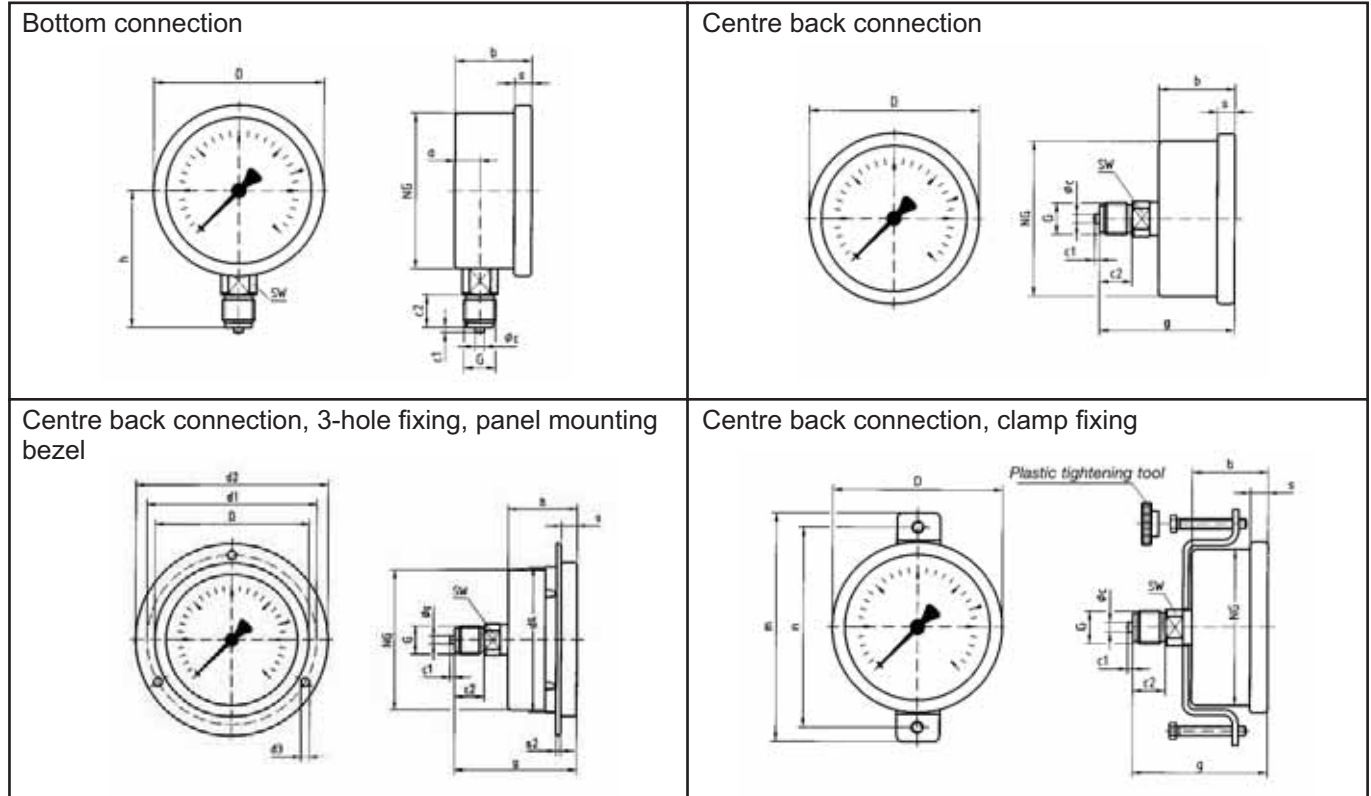

Nominal Size	a	a1	b	b1	Øc	c1	c2	d1*	d2	d3*	d4	D	G	g	h	m	n	s	s1	s2	SW
63 mm	9.5	13	30.5	34	5	2	13	75	85	3.6	64	68	G¼B	53.3	53	94	82	7	5.5	2	14

### SPG 100mm

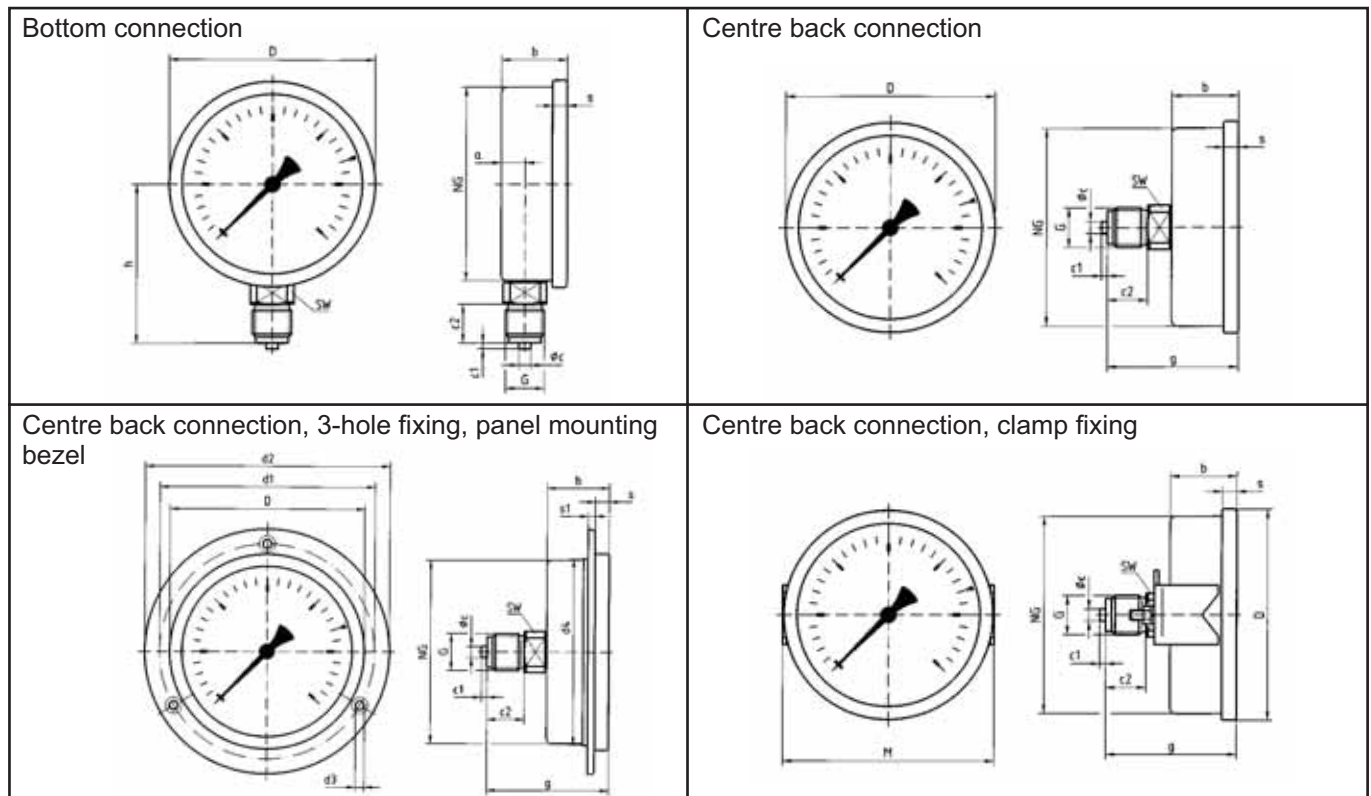

Nominal Size	a	b	Øc	c1	c2	d1	d2	d3	d4	D	g	G	h	M	s	s1	SW
100 mm	11.8	33.5	6	3	20	116	132	4.8	101	106	76.5	G½B	90	106	7	3.8	22

## Ordering Codes

63mm dia., S.S. Case, 1/4"BSPP, Dual Scale - bar/psi, Bottom Entry, Stem Mount



Code	Description
SPG63(-1/+0)1-SB	-1/0 BAR(-14.5-0 PSI) COMPOUND VAC/GAUGE
SPG63(-1/+3)1-SB	-1/+3BAR(-14.5-42 PSI) COMPOUND VAC/GAUGE
SPG63-0.6-1-SB	0-0.6 BAR(9 PSI) PRESSURE GAUGE
SPG63-1-1-SB	0-1 BAR(14.5 PSI) PRESSURE GAUGE
SPG63-3-1-SB	0-3 BAR(43.5 PSI) PRESSURE GAUGE
SPG63-4-1-SB	0-4 BAR(58 PSI) PRESSURE GAUGE
SPG63-6-1-SB	0 - 6 BAR(90 PSI) PRESSURE GAUGE
SPG63-10-1-SB	0 - 10 BAR(145 PSI) PRESSURE GAUGE
SPG63-16-1-SB	0 - 16 BAR(230 PSI) PRESSURE GAUGE
SPG63-25-1-SB	0 - 25 BAR(360 PSI) PRESSURE GAUGE
SPG63-40-1-SB	0 - 40 BAR(580 PSI) PRESSURE GAUGE
SPG63-60-1-SB	0 - 60 BAR(850 PSI) PRESSURE GAUGE
SPG63-100-1-SB	0 - 100 BAR(1450 PSI) PRESSURE GAUGE
SPG63-160-1-SB	0 - 160 BAR(2300 PSI) PRESSURE GAUGE
SPG63-250-1-SB	0 - 250 BAR(3600 PSI) PRESSURE GAUGE
SPG63-315-1-SB	0-315 BAR(4560 PSI) PRESSURE GAUGE
SPG63-400-1-SB	0 - 400 BAR(5800 PSI) PRESSURE GAUGE
SPG63-500-1-SB	0-500 BAR(7250 PSI) PRESSURE GAUGE
SPG63-600-1-SB	0 - 600 BAR(8500 PSI) PRESSURE GAUGE
SPG63-680-1-SB	0 - 680 BAR(10000 PSI) PRESSURE GAUGE
SPG63-1000-1-SB	0-1000 BAR(14500 PSI) PRESSURE GAUGE

100mm dia., S.S. Case, 1/2"BSPP, Dual Scale - bar/psi, Rear Entry



Code	Description
SPG100(-1/+3)1-RB	-1+3 BAR(-14.5-42 PSI) COMPOUND VAC/GAUGE
SPG100-6-1-RB	0-6 BAR(90 PSI) PRESSURE GAUGE
SPG100-10-1-RB	0 - 10 BAR(145 PSI) PRESSURE GAUGE
SPG100-16-1-RB	0-16 BAR(230 PSI) PRESSURE GAUGE
SPG100-25-1-RB	0-25 BAR(360 PSI) PRESSURE GAUGE
SPG100-40-1-RB	0 - 40 BAR(580 PSI) PRESSURE GAUGE
SPG100-60-1-RB	0 - 60 BAR(850 PSI) PRESSURE GAUGE
SPG100-80-1-RB	0-80 BAR(1160 PSI) PRESSURE GAUGE
SPG100-100-1-RB	0-100 BAR(1450 PSI) PRESSURE GAUGE
SPG100-160-1-RB	0-160 BAR(2300 PSI) PRESSURE GAUGE
SPG100-250-1-RB	0 -250 BAR(3600 PSI) PRESSURE GAUGE
SPG100-315-1-RB	0 -315 BAR(4560 PSI) PRESSURE GAUGE
SPG100-400-1-RB	0 -400 BAR(5800 PSI) PRESSURE GAUGE
SPG100-600-1-RB	0-600 BAR(8500 PSI) PRESSURE GAUGE
SPG100-700-1-RB	0-700 BAR(10150 PSI) PRESSURE GAUGE
SPG100-1000-1-RB	0-1000 BAR(14500 PSI) PRESSURE GAUGE

63mm dia., S.S. Case, 1/4"BSPP, Dual Scale - bar/psi, Rear Entry



Code	Description
SPG63(-1/+0)1-RBU	-1/0 BAR(-14.5-0 PSI) COMPOUND VAC/GAUGE
SPG63(-1/+3)1-RBU	-1/+3BAR(-14.5-42 PSI) COMPOUND VAC/GAUGE
SPG63-6-1-RBU	0 - 6 BAR(90 PSI) PRESSURE GAUGE
SPG63-10-1-RBU	0 - 10 BAR(145 PSI) PRESSURE GAUGE
SPG63-16-1-RBU	0 - 16 BAR(230 PSI) PRESSURE GAUGE
SPG63-25-1-RBU	0 - 25 BAR(360 PSI) PRESSURE GAUGE
SPG63-40-1-RBU	0 - 40 BAR(580 PSI) PRESSURE GAUGE
SPG63-60-1-RBU	0 - 60 BAR(850 PSI) PRESSURE GAUGE
SPG63-100-1-RBU	0 - 100 BAR(1450 PSI) PRESSURE GAUGE
SPG63-160-1-RBU	0 - 160 BAR(2300 PSI) PRESSURE GAUGE
SPG63-250-1-RBU	0 - 250 BAR(3600 PSI) PRESSURE GAUGE
SPG63-315-1-RBU	0-315 BAR(4560 PSI) PRESSURE GAUGE
SPG63-400-1-RBU	0 - 400 BAR(5800 PSI) PRESSURE GAUGE
SPG63-500-1-RBU	0-500 BAR(7250 PSI) PRESSURE GAUGE
SPG63-600-1-RBU	0-600 BAR(8500 PSI) PRESSURE GAUGE
SPG63-680-1-RBU	0 - 680 BAR(10000 PSI) PRESSURE GAUGE
SPG63-700-1-RBU	0-700 BAR(10150 PSI) PRESSURE GAUGE
SPG63-1000-1-RBU	0-1000 BAR(14500 PSI) PRESSURE GAUGE

63mm dia., S.S. Case, 1/4"BSPP, Dual Scale - kpa/psi, Stem Mount



Code	Description
SPG63-100/0-10-SB	-100/+0 KPA(-14.5/+0PSI) COMPOUND VAC/GAUGE
SPG63-60-10-SB	0-60 KPA (9 PSI) PRESSURE GAUGE
SPG63-100-10-SB	0-100 KPA (14.5 PSI) PRESSURE GAUGE
SPG63-250-10-SB	0-250 KPA (360 PSI) PRESSURE GAUGE
SPG63-600-10-SB	0-600 KPA (850 PSI) PRESSURE GAUGE
SPG63-1000-10-SB	0-1000 KPA (145 PSI) PRESSURE GAUGE
SPG63-1600-10-SB	0-1600 KPA (230 PSI) PRESSURE GAUGE
SPG63-2500-10-SB	0-2500 KPA (360 PSI) PRESSURE GAUGE
SPG63-4000-10-SB	0-4000 KPA (580 PSI) PRESSURE GAUGE
SPG63-10000-10-SB	0-10000 KPA (1450 PSI) PRESSURE GAUGE
SPG63-25000-10-SB	0-25000 KPA (3650 PSI) PRESSURE GAUGE
SPG63-31500-10-SB	0-31500 KPA (4560 PSI) PRESSURE GAUGE
SPG63-50000-10-SB	0-50000 KPA(7250 PSI) PRESSURE GAUGE
SPG63-100000-10-SB	0-100000 KPA (14500 PSI) PRESSURE GAUGE

100mm dia., S.S. Case, 1/2"BSPP, Dual Scale - bar/psi, Bottom Entry, Stem Mount



Code	Description
SPG100-6-1-SB	0-6 BAR(90 PSI) PRESSURE GAUGE
SPG100-10-1-SB	0 - 10 BAR(145 PSI) PRESSURE GAUGE
SPG100-16-1-SB	0-16 BAR(230 PSI) PRESSURE GAUGE
SPG100-25-1-SB	0-25 BAR(360 PSI) PRESSURE GAUGE
SPG100-40-1-SB	0 - 40 BAR(580 PSI) PRESSURE GAUGE
SPG100-60-1-SB	0 - 60 BAR(850 PSI) PRESSURE GAUGE
SPG100-100-1-SB	0 -100 BAR(1450 PSI) PRESSURE GAUGE
SPG100-160-1-SB	0 -160 BAR(2300 PSI) PRESSURE GAUGE
SPG100-250-1-SB	0-250 BAR(3600 PSI) PRESSURE GAUGE
SPG100-315-1-SB	0-315 BAR(4560 PSI) PRESSURE GAUGE
SPG100-400-1-SB	0 -400 BAR(5800 PSI) PRESSURE GAUGE
SPG100-600-1-SB	0 -600 BAR(8500 PSI) PRESSURE GAUGE
SPG100-680-1-SB	0-680 BAR(9860 PSI) PRESSURE GAUGE
SPG100-700-1-SB	0-700 BAR(10150 PSI) PRESSURE GAUGE
SPG100-1000-1-SB	0-1000 BAR(14500 PSI) PRESSURE GAUGE

63mm dia., S.S. Case, 1/4"BSPP, Dual Scale - kpg/psi, Rear Entry



Code	Description
SPG63-100/+0-10-RBU	-100/+0 KPA(-14.5/+0PSI) COMPOUND VAC/GAUGE
SPG63(-100+300)10-RBU	-100/+300KPA/PSI COMP/VAC PRESS GAUGE/RE
SPG63-60-10-RBU	0-60 KPA (9 PSI) PRESSURE GAUGE
SPG63-100-10-RBU	0-100 KPA (14.5 PSI) PRESSURE GAUGE
SPG63-250-10-RBU	0-250 KPA (360 PSI) PRESSURE GAUGE
SPG63-600-10-RBU	0-600 KPA (850 PSI) PRESSURE GAUGE
SPG63-1000-10-RBU	0-1000 KPA (145 PSI) PRESSURE GAUGE
SPG63-1600-10-RBU	0-1600 KPA (230 PSI) PRESSURE GAUGE
SPG63-2500-10-RBU	0-2500 KPA (360 PSI) PRESSURE GAUGE
SPG63-4000-10-RBU	0-4000 KPA (580 PSI) PRESSURE GAUGE
SPG63-10000-10-RBU	0-10000 KPA (1450 PSI) PRESSURE GAUGE
SPG63-31500-10-RBU	0-31500 KPA (4560 PSI) PRESSURE GAUGE
SPG63-100000-10-RBU	0-100000 KPA (14500 PSI) PRESSURE GAUGE

## Gauge Accessories



### Panel Mount Bracket

Code	Description
SPG63-BR	BRACKET - 63MM PANEL MOUNT GAUGE
SPG100-BR	BRACKET - 100MM PANEL MOUNT GAUGE



### Front Flange Bezel

Code	Description
SPG63-F	FLANGE - 63MM PANEL MOUNT GAUGE
SPG100-F	FLANGE - 100MM PANEL MOUNT GAUGE



### Gauge Protector

Code	Description
SPG-63-RGP	RUBBER GAUGE PROTECTOR



### Gauge Swivel Adaptors with O-Ring Seal

Code	Description
FT299/88	GAUGE ADAPT.(SW)1/8BSPP(F)-1/8BSPT(M)
FT299/44	GAUGE ADAPT.(SW)1/4BSPP(F)-1/4BSPT(M)
FT299/42	GAUGE ADAPT.(SW)1/4BSPP(F)-1/2BSPT(M)
FT299/24S	GAUGE ADAPT.(SW)1/2BSPP(F)-1/4BSPT(M)
FT299/24B	GAUGE ADAPT.(SW) 1/2 BSPP(F)-1/4 BSPP(M)
FT299/22	GAUGE ADAPT.(SW)1/2BSPP(F)-1/2BSPT(M)



### Gauge Isolator Valves

Code	Description
SWS-B04-S	VALVE,ISOLATOR-SINGLE STN GAUGE
SWS-B04-M	VALVE,ISOLATER-MULTI STN GAUGE

\* Multi-station suits 6 gauge points



### Gauge Saver - GSB P. max - 138 Bar (2000 PSI)

Code	Description
GSB-1	1/4" BSP BRASS GAUGE SAVER COMPLETE
GSB-3	3/8" BSP BRASS GAUGE SAVER COMPLETE
GSB-5	1/2" BSP BRASS GAUGE SAVER COMPLETE

## Digital Pressure Gauges

- +0.5% full scale accuracy
- Measurement of pressure peaks with 10ms-sample rate
- Operating temperature: -10°C...50°C (14...122°F)
- Back lighted display
- Battery-life indicator 1,500 hours (2x1.5 V battery)
- Pressure Connection G 1/4 BSPP (stainless steel)
- Zinc die cast housing with TPE protective cover
- Available Units (display): bar, PSI, Mpa, kPa, mbar



### Digital Pressure Gauges

Code	Description
SPG-DIGI-B0016	-1 -+16 BAR(-14.5-+230)PSI DIGITAL GAUGE
SPG-DIGI-B0100	0-100 BAR (0-1450)PSI DIGITAL GAUGE
SPG-DIGI-B0400	0-400 BAR(0-5800)PSI DIGITAL GAUGE
SPG-DIGI-B0600	0-600 BAR (0-8700)PSI DIGITAL GAUGE



### Digital Pressure Test Kits

Code	Description
SMB20/80-1-DIGI-X	PLASTIC BOX,1 GAUGE 80MM TEST 20 FITTING
SMB12/80-1-DIGI-X	PLASTIC BOX,1 GAUGE 80MM TEST 12 FITTING

## Other Pressure Gauges Available on Request

### Order Code - Stainless Steel Pressure Gauges

SPG	63	160	1	R	B	U
-----	----	-----	---	---	---	---

Size	
63	63 mm face
100	100 mm face

Pressure Range
Standard-Pressure will be indicated in the relevant catalogues
<b>STANDARD FORMAT:</b> 5 Digits only end value - reference to outside scale
Other values for vacuum gauges to be created as follows: Indicate BEGINNING and END (e.g: <<(-1)-00160>>

Connection
S = Stem mount R = Panel mount

Thread Form	
B04	¼" BSPP (63 mm face)
B08	½" BSPP (100 mm face)
N04	¼" NPT (63 mm face)
N08	½" NPT (100 mm face)
<b>Specials available on request</b>	
T04	¼" BSPT (63 mm face)
U04	7/16-20-UNF (063 mm face)
M14	M14x1.5 (63 mm face)

Normally Stocked

Scale Design		
1	BAR / PSI	BAR outside / PSI inside - standard
2	BAR	BAR - Scale
3	PSI	PSI - Scale
4	KGM / PSI	kg/cm <sup>2</sup> outside / PSI inside
5	PSI / BAR	PSI outside / BAR inside
6	MPa	MPa - Scale
7	MPa / PSI	MPa outside / PSI inside
8	MPa / KGF / CM <sup>2</sup>	MPa outside / kg/cm <sup>2</sup> inside
9	KGF / CM <sup>2</sup> / MPa	kg/cm <sup>2</sup> outside / MPa inside
10	KPa / PSI	KPa outside / PSI inside
11	BAR / MPa	BAR outside / MPa inside
12	BAR / KPa	BAR outside / KPa inside
13	KPa	KPa - Scale
14	mbar	mbar - Scale

Scale "1" = Normally stocked  
Scale "10" = Normally stocked

Accessories	
(U/F only for panel mount option)	
omit	none
U	U-bracket
F	Front flange
R	Rear flange
UF	U-bracket & Front flange

Logo
none = STAUFF (standard) Private label available on request

**Pressure information always refers to setting of the outside scale.**

Type	
SPG	s/steel pressure gauge

## Metal Case Test Kits



Test Hose included in Kit

Metal gauge boxes are available with 2, 3, 4, 5 & 6 gauges in a standard metal box which carries test hoses in the base. Compartments available to store Test couplings and adaptors sold separately. The top can be slipped off the hinges for hanging close to the test point by the top mounted handle. The test boxes use the SPG series of gauges and therefore the pressure ranges need to be selected from page 3. Either Stauff Test 20 or Stauff Test 12 can be selected as the means connection.

### Ordering Code

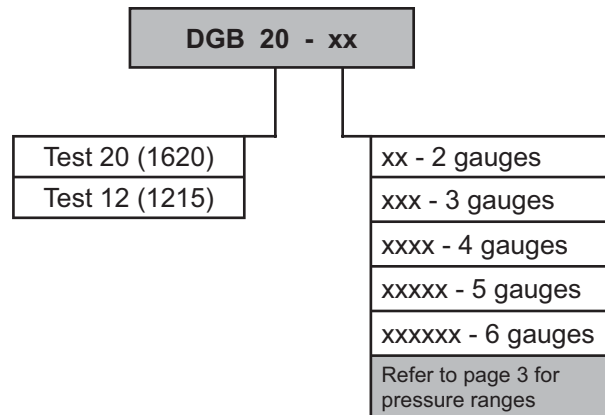

## Plastic Case Test Kits - Hand Held Gauges



Plastic Case Test Kit - 63mm Gauge

Plastic gauge boxes are available with 1, 2 & 3 63mm gauges and 1 gauge in 100mm, in a standard plastic box which carries test points and hoses in the base. The test boxes use the SPG series of gauges and therefore the pressure ranges need to be selected from page 3. Stauff Test 20 or Test 12 can be selected as the means connection.

### Ordering Code

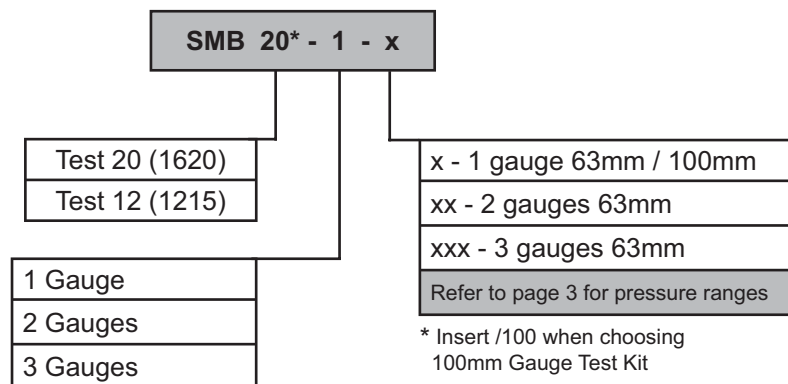

Plastic Case Test Kit -100mm Gauge

#### Contents 1 Gauge Box

- 1 - SMS20-2000A test hose 2m long
- 1 - Pressure Gauge 63mm dia (selected)
- 1 - SMA20G1/4P-OR gauge to hose adaptor
- 1 - SMD20G1/4P-OR direct gauge adaptor
- 1 - SMK20G1/4PC test coupling (1/4"BSPP)
- 1 - SMK20M10X1PA test coupling (M10x1)
- 1 - SRS20G3/8 thread adaptor 3/8"BSP
- 1 - SRS20G1/2 thread adaptor 1/2"BSP

#### Contents 2 Gauge Box

- 1 - SMS20-2000A test hose 2m long
- 2 - Pressure Gauge 63mm dia (selected)
- 1 - SMA20G1/4P-OR gauge to hose adaptor
- 1 - SMD20G1/4P-OR direct gauge adaptor
- 1 - SMK20G1/4PC test coupling (1/4"BSPP)
- 1 - SMK20M10X1PA test coupling (M10x1)
- 1 - SRS20G3/8 thread adaptor 3/8"BSP
- 1 - SRS20G1/2 thread adaptor 1/2"BSP

#### Contents 3 Gauge Box

- 2 - SMS20-2000A test hose 2m long
- 3 - Pressure Gauge 63mm dia (selected)
- 1 - SMA20G1/4P-OR gauge to hose adaptor
- 2 - SMD20G1/4P-OR direct gauge adaptor
- 3 - SMK20G1/4PC test coupling (1/4"BSPP)
- 3 - SMK20M10X1PA test coupling (M10x1)
- 1 - SRS20G3/8 thread adaptor 3/8"BSP
- 1 - SRS20G1/2 thread adaptor 1/2"BSP