



ATLANTIC
Fluid Tech



ATLANTIC
Fluid Tech

GENERAL CATALOGUE **20.1**

Innovative & High Performance Hydraulics



1800-OILSOL
1800-645765

<https://oilsolutions.com.au/>

sales@oilsolutions.com.au



ATLANTIC
Fluid Tech



OIL SOLUTIONS

PO Box 38
Strathfieldsaye, VIC, 3551
1800 OIL SOL
1800 645 765

sales@oilsolutions.com.au

www.oilsolutions.com.au

"For All Your Hydraulic Needs"

**SECTION
1**

Relief Valves

SECTION 1

RELIEF VALVES



Hydraulic scheme	Valve description	Valve type	Rated flow (l/min)	Max. pressure (bar)	Installation	Main port size or cavity type	Page
	CPLN-005-DPNA	Direct acting, poppet type	1,5	460	Cartridge	VP000005	1.01.010
	CPLN-010-DHNA	Direct acting, poppet type	3	350	Cartridge	SAE-08-2N	1.01.020 1.01.030
	KPLN-010-DPNA	Direct acting, poppet type	3	350	In line	G1/4" - G3/8"	1.01.040
	CPLN-020-DPNA	Direct acting, poppet type	20	420	Cartridge	SAE-08-2N	1.01.050 1.01.060
	KPLN-020-DPNA	Direct acting, poppet type	20	350	In line	G1/4" - G3/8"	1.01.070
	CPLN-030-DPNA	Direct acting, poppet type	30	420	Cartridge	VP000008	1.01.080
	CPLN-030-DHNA	Direct acting, poppet type	30	350	Cartridge	VP000008	1.01.090
	CPLN-030-DHAA	Direct acting, poppet type	30	350	Cartridge	VP000008	1.01.100
	KPLN-030-DPNA	Direct acting, poppet type	30	350	In line	G3/8" - G1/2"	1.01.110
	CPLN-080-DPNA	Direct acting, poppet type	80	420	Cartridge	VP000086	1.01.120
	KPLN-080-DPNA	Direct acting, poppet type	80	350	In line	G1/2" - G3/4"	1.01.130
	CPLN-120-DPNA	Direct acting, poppet type	120	350	Cartridge	VP000388	1.01.140
	CPLT-030-DPNA	Direct acting, poppet type, compensated	30	350	Cartridge	VP000008	1.02.150
	CPLT-030-DHNA	Direct acting, poppet type, compensated	30	350	Cartridge	VP000008	1.02.160
	CPLT-080-DHNA	Direct acting, poppet type, compensated	80	420	Cartridge	VP000086	1.02.170
	CPLT-080-DHNA	Direct acting, poppet type, chamber vented	80	420	Cartridge	SAE-16-3C	1.02.180
	CPLN-040-DHGD	Differential, poppet type	40	350	Cartridge	VP000080	1.03.190
	CPLN-090-DHGA	Direct acting, poppet type	90	380	Cartridge	VP000249	1.03.200
	CPAN-090-DHGA	Direct, poppet type, anticavitation	90	380	Cartridge	VP000249	1.03.210
	CPLN-150-DHGD	Differential, poppet type	150	350	Cartridge	VP000070	1.03.220
	KPLN-150-DHGD	Differential, poppet type	150	350	In line	G1/2" - G3/4"	1.03.230
	CPLN-160-DHGA	Direct, poppet type	160	400	Cartridge	VP000250	1.03.240
	CPAN-160-DHGA	Direct, poppet type, anticavitation	160	400	Cartridge	VP000250	1.03.250
	CPLN-250-DHGD	Differential, poppet type	250	350	Cartridge	VP000154	1.03.260
KPLN-250-DHGD	Differential, poppet type	250	350	In line	G1"	1.03.270	
	CPLN-120-PSNA	Pilot operated, spool type	120	350	Cartridge	SAE-10-2N	1.04.280
	KPLN-120-PSNA	Pilot operated, spool type	120	350	In line	G3/8" - G1/2"	1.04.290
	CPLN-300-PSNA	Pilot operated, spool type	300	350	Cartridge	SAE-16-2N	1.04.300
	CPLN-500-PHNA	Pilot operated, spool type	500	350	Cartridge	SAE-20-2N	1.04.310
	CPLT-120-PSNA	Pilot operated, spool type, compensated	120	350	Cartridge	SAE-10-2N	1.05.320
	CPLV-120-PSNA	Pilot operated, spool type	120	350	Cartridge	SAE-10-2N	1.06.330
	CPSK-001-PPNA	Direct acting, poppet type, kick down type	1	350	Cartridge	SAE-10-2N	1.07.340

RELIEF VALVE

CPLN-005-DPNA

DIRECT ACTING
WITH FILTER

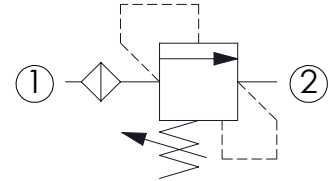
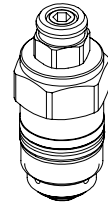
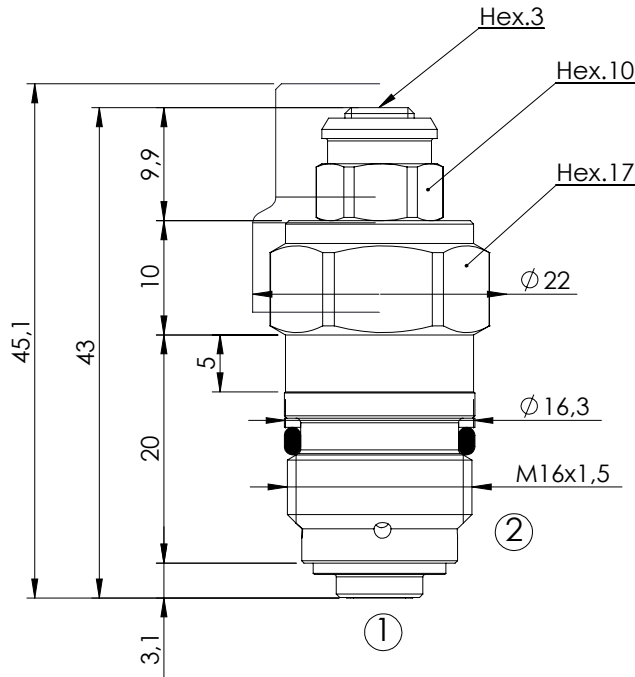

SPECIFICATIONS

Max. operating pressure:	460 bar
Rated flow:	1,5 l/min
Cavity:	VP000005
Weight:	0,05 kg

SEALING CAP

Ordering code:
ST000014

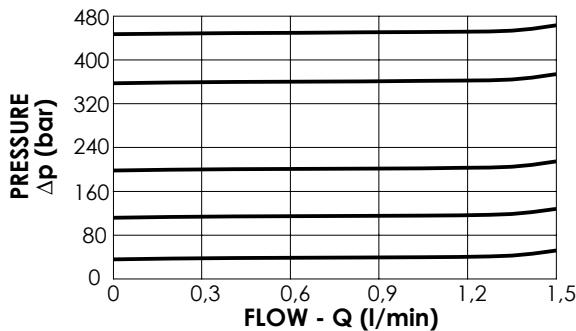
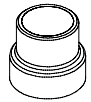

NOTES

Installation torque:	27 - 33 Nm
Seal kit:	RC700005

ORDERING CODES

Quick code	Description	Standard setting (bar/cracking pressure)	Adjustment range (bar)	Pressure increase (bar/turn)
CP000015	CPLN-005-DPNA-PF-005-N460	460	150-460	236
CP000002	CPLN-005-DPNA-PF-005-N350	350	120-350	165
CP000029	CPLN-005-DPNA-PF-005-N200	200	100-200	75
CP000030	CPLN-005-DPNA-PF-005-N100	100	25-100	41
CP000277	CPLN-005-DPNA-PF-005-N040	40	10-40	22

RELIEF VALVE

CPLN-010-DHNA

DIRECT ACTING
HARDENED SEAT

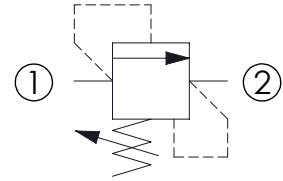
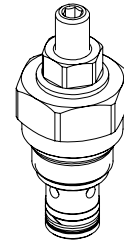
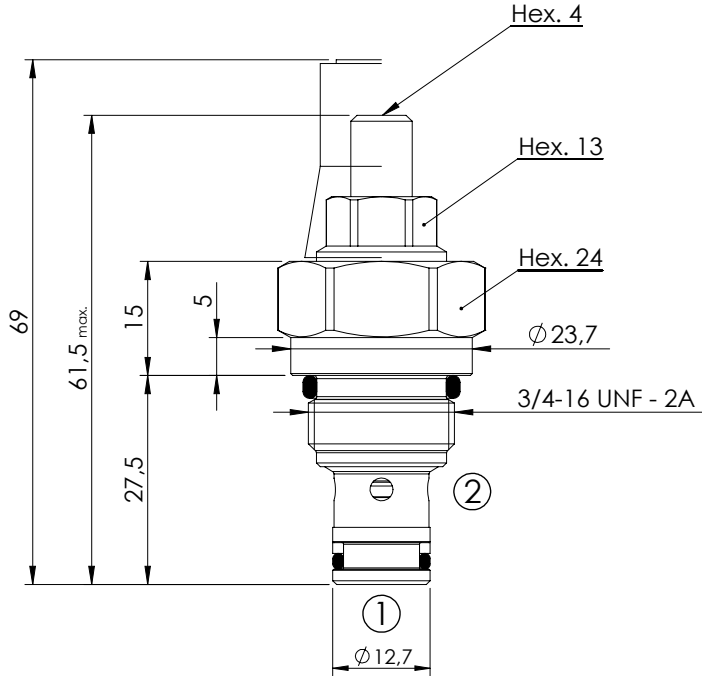

SPECIFICATIONS

Max. operating pressure:	350 bar
Rated flow:	3 l/min
Cavity:	SAE-08-2N
Weight:	0,1 kg

SEALING CAP

Ordering code:
AT000020

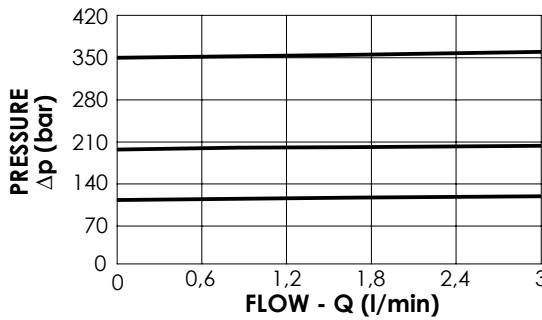
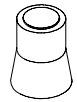

NOTES

Installation torque:	45 - 50 Nm
Seal kit:	RA700081

ORDERING CODES

Quick code	Description	Standard setting (bar, Q=0,2 l/min)	Adjustment range (bar)	Pressure increase (bar/turn)
CP000006	CPLN-010-DHNA-SN-S08-N350	350	140-350	142
CP000055	CPLN-010-DHNA-SN-S08-N200	200	90-210	87
CP000056	CPLN-010-DHNA-SN-S08-N100	100	35-110	47

RELIEF VALVE

CPLN-010-DHNA

DIRECT ACTING
HARDENED SEAT

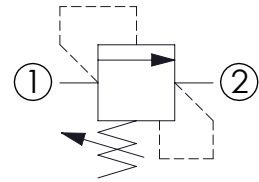
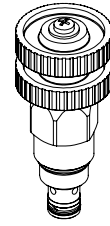
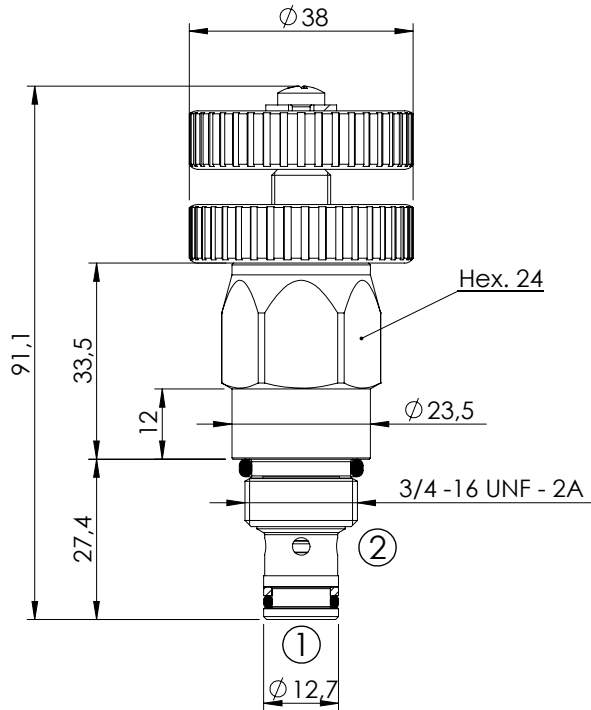

SPECIFICATIONS

Max. operating pressure:	350 bar
Rated flow:	3 l/min
Cavity:	SAE-08-2N
Weight:	0,18 kg

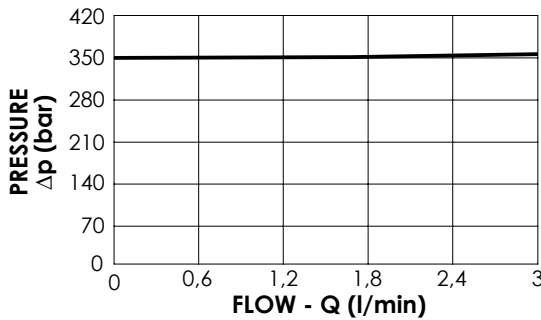

NOTES

Installation torque:	45 - 50 Nm
Seal kit:	RA700081

ORDERING CODES

Quick code	Description	Standard setting (bar, cracking pressure)	Adjustment range (bar)	Pressure increase (bar/turn)
CP000172	CPLN-010-DHNA-VN-S08-N350	350	20-350	83

RELIEF VALVE IN BODY

KPLN-010-DPNA

DIRECT ACTING
HARDENED SEAT

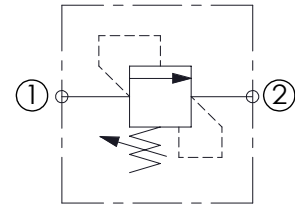
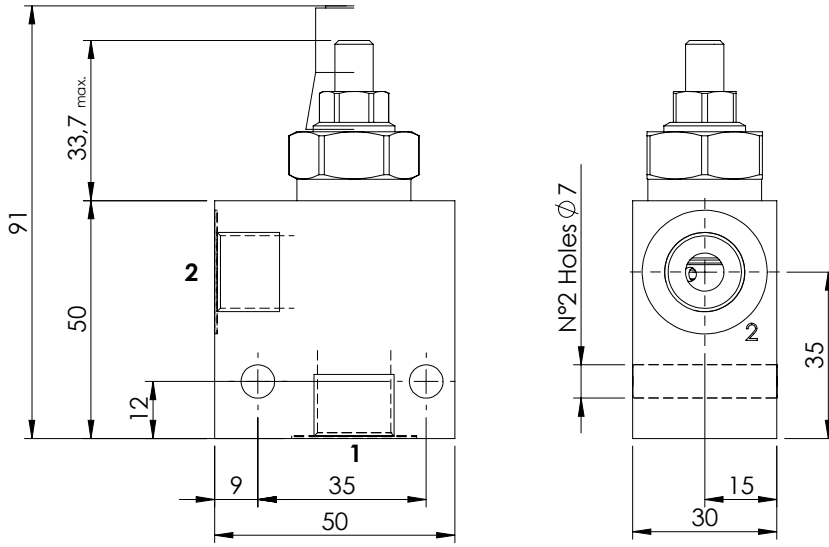
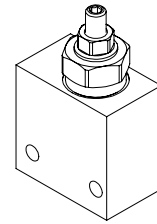
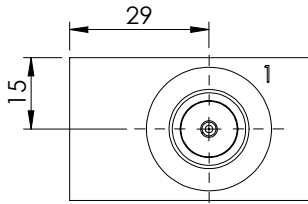

SPECIFICATIONS

Max. operating pressure:	350 bar
Rated flow:	3 l/min
Manifold:	Aluminium
Weight:	0,25 kg

SEALING CAP

Ordering code:
AT000020

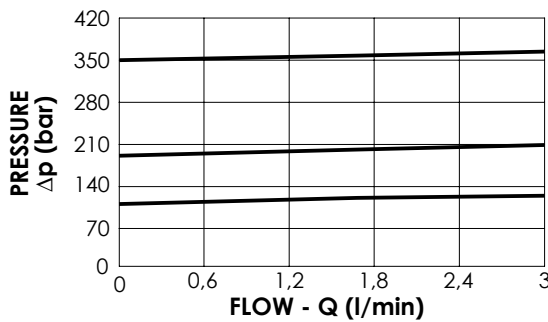
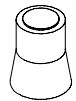

ORDERING CODES

Quick code	Description	Main ports size	Standard setting (bar, Q=0.2 l/min)	Adjustm. range (bar)	Pressure increase (bar/turn)
KP000041	KPLN-010-DPNA-SN-G38-N350	P,T: G 3/8"	350	140-350	142
KP000042	KPLN-010-DPNA-SN-G38-N200	P,T: G 3/8"	200	90-210	87
KP000043	KPLN-010-DPNA-SN-G38-N100	P,T: G 3/8"	100	35-110	47
KP000044	KPLN-010-DPNA-SN-G14-N350	P,T: G 1/4"	350	140-350	142
KP000045	KPLN-010-DPNA-SN-G14-N200	P,T: G 1/4"	200	90-210	87
KP000046	KPLN-010-DPNA-SN-G14-N100	P,T: G 1/4"	100	35-110	47

RELIEF VALVE

CPLN-020-DPNA

**DIRECT ACTING
STABILIZED PISTON**

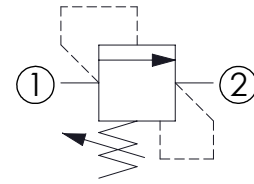
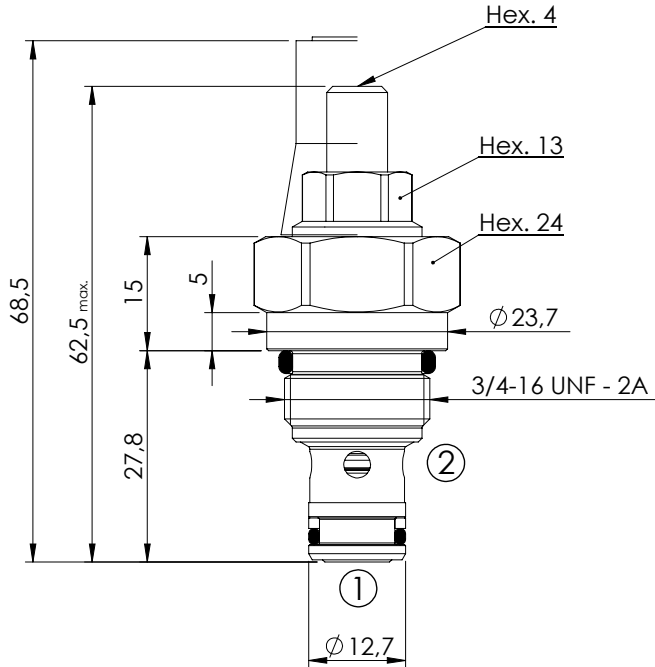
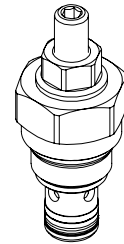

SPECIFICATIONS

Max. operating pressure:	420 bar
Rated flow:	20 l/min
Cavity:	SAE-08-2N
Weight:	0,1 kg

SEALING CAP

Ordering code:
AT000020

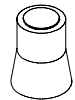

NOTES

Installation torque:	45-50 Nm
Seal kit:	RA700081

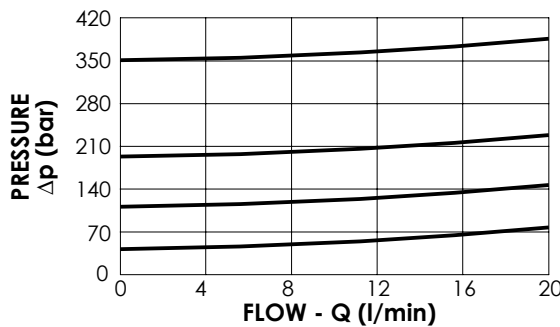

ORDERING CODES

Quick code	Description	Standard setting (bar, Q=5 l/min)	Adjustment range (bar)	Pressure increase (bar/turn)
CP000168	CPLN-020-DPNA-SN-S08-N420	350	200-420	207
CP000025	CPLN-020-DPNA-SN-S08-N350	350	175-350	177
CP000007	CPLN-020-DPNA-SN-S08-N200	200	105-210	80
CP000028	CPLN-020-DPNA-SN-S08-N100	100	35-140	49
CP000027	CPLN-020-DPNA-SN-S08-N050	50	10-70	26

RELIEF VALVE

CPLN-020-DPNA

DIRECT ACTING

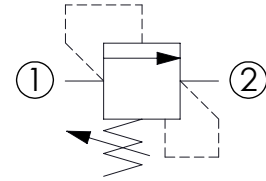
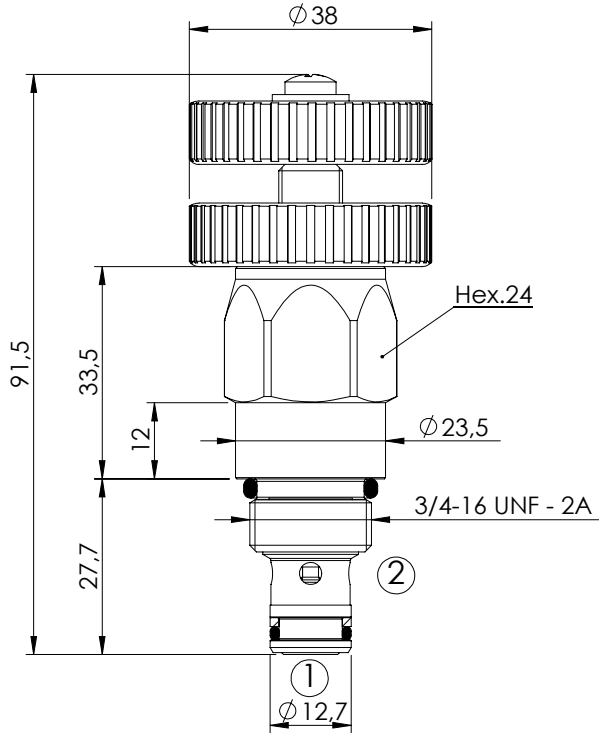
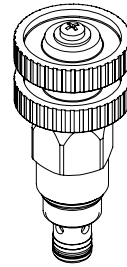

SPECIFICATIONS

Max. operating pressure:	350 bar
Rated flow:	20 l/min
Cavity:	SAE-08-2N
Weight:	0,18 kg

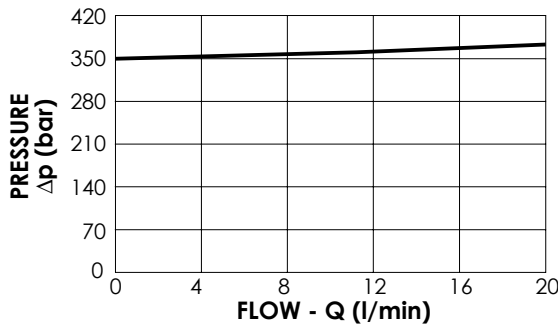

NOTES

Installation torque:	45 - 50 Nm
Seal kit:	RA700081

ORDERING CODES

Quick code	Description	Standard setting (bar, Q=5 l/min)	Adjustment range (bar)	Pressure increase (bar/turn)
CP000173	CPLN-020-DPNA-VN-S08-N350	350	20-350	56

RELIEF VALVE IN BODY

KPLN-020-DPNA

DIRECT ACTING
STABILIZED PISTON

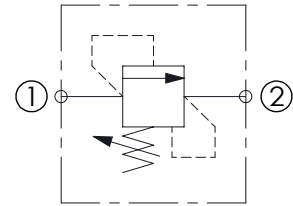
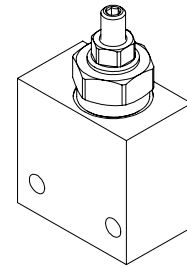
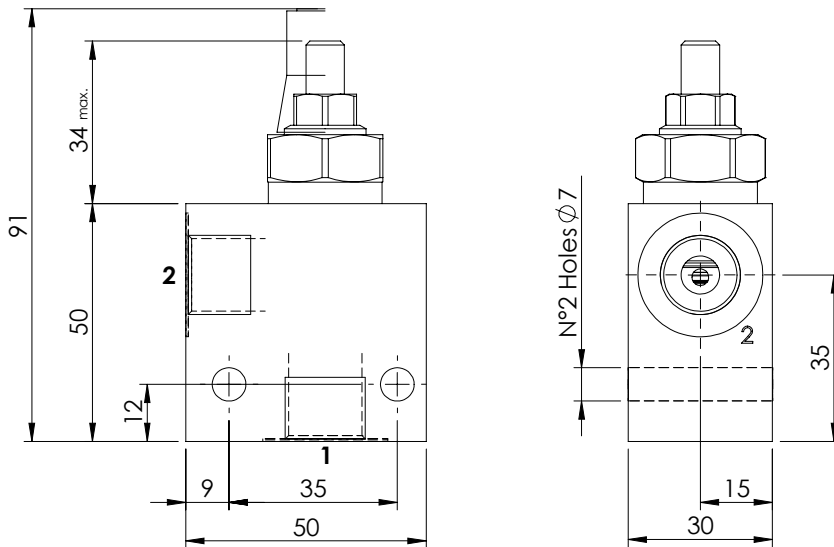
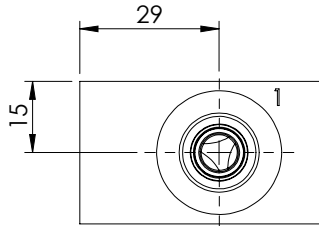

SPECIFICATIONS

Max. operating pressure:	350 bar
Rated flow:	20 l/min
Manifold:	Aluminium
Weight:	0,25 kg

SEALING CAP

Ordering code:
AT000020

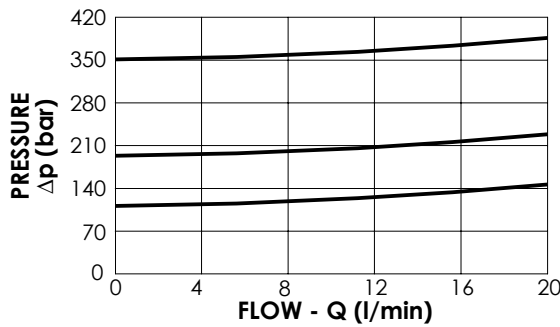

ORDERING CODES

Quick code	Description	Main ports size	Standard setting (bar, Q=5 l/min)	Adjustm. range (bar)	Pressure increase (bar/turn)
KP000010	KPLN-020-DPNA-SN-G38-N350	P,T: G 3/8"	350	175-350	177
KP000037	KPLN-020-DPNA-SN-G38-N200	P,T: G 3/8"	200	105-210	80
KP000038	KPLN-020-DPNA-SN-G38-N100	P,T: G 3/8"	100	35-140	49
KP000008	KPLN-020-DPNA-SN-G14-N350	P,T: G 1/4"	350	175-350	177
KP000039	KPLN-020-DPNA-SN-G14-N200	P,T: G 1/4"	200	105-210	80
KP000040	KPLN-020-DPNA-SN-G14-N100	P,T: G 1/4"	100	35-140	49

RELIEF VALVE

CPLN-030-DPNA

DIRECT ACTING
STABILIZED PISTON

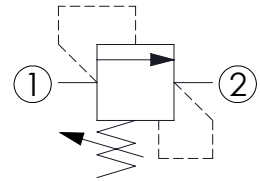
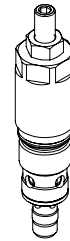
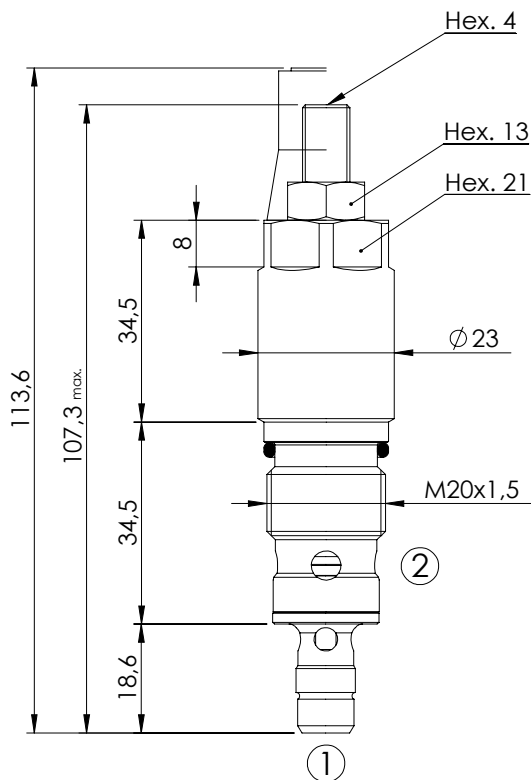

SPECIFICATIONS

Max. operating pressure:	420 bar
Rated flow:	30 l/min
Cavity:	VP000008
Weight:	0,17 kg

SEALING CAP

Ordering code:
AT000020

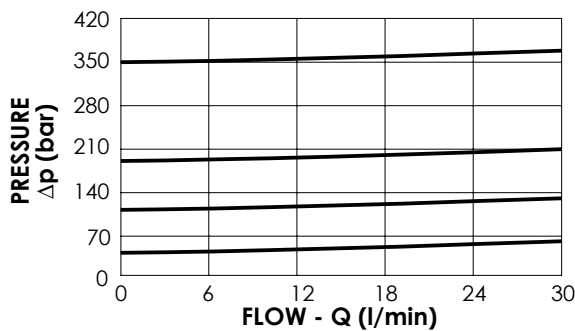
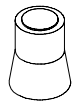

NOTES

Installation torque:	40 - 45 Nm
Seal kit:	RC700008

ORDERING CODES

Quick code	Description	Standard setting (bar, Q=5 l/min)	Adjustment range (bar)	Pressure increase (bar/turn)
CP000124	CPLN-030-DPNA-HN-008-N420	350	250-420	104
CP000001	CPLN-030-DPNA-HN-008-N350	350	100-350	91
CP000019	CPLN-030-DPNA-HN-008-N200	200	50-210	42
CP000020	CPLN-030-DPNA-HN-008-N100	100	30-100	20
CP000032	CPLN-030-DPNA-HN-008-N050	50	10-50	10

RELIEF VALVE

CPLN-XXX-DHNA

**DIRECT ACTING
STABILIZED PISTON
HARDENED SEAT**

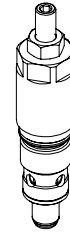
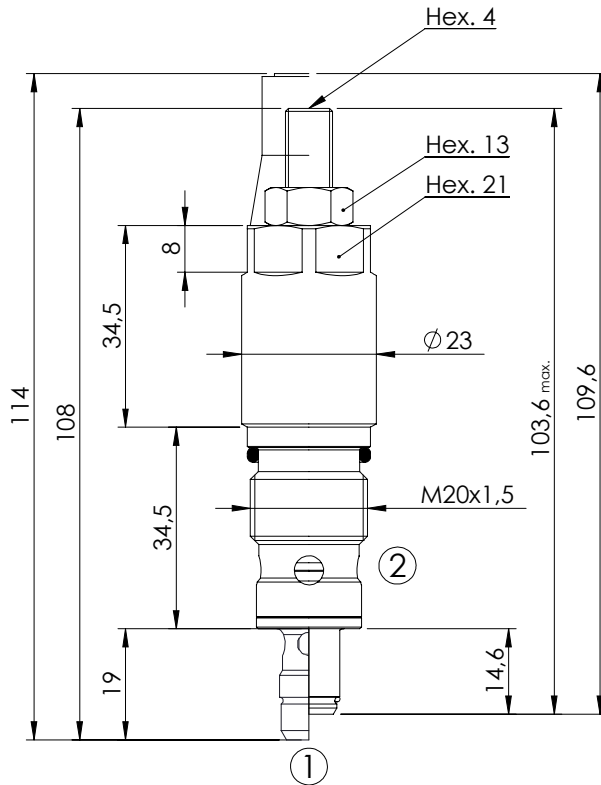

With Filter

Without Filter

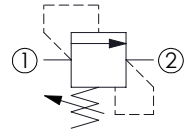
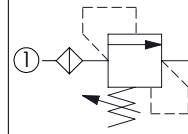

SPECIFICATIONS

Max. operating pressure:	500 bar
Max. operating pressure on T:	350 bar
Rated flow:	See table
Cavity:	VP000008
Weight:	0,17 kg

SEALING CAP

Ordering code:
AT000020



NOTES

Installation torque:	40-45 Nm
Seal kit:	RC700008

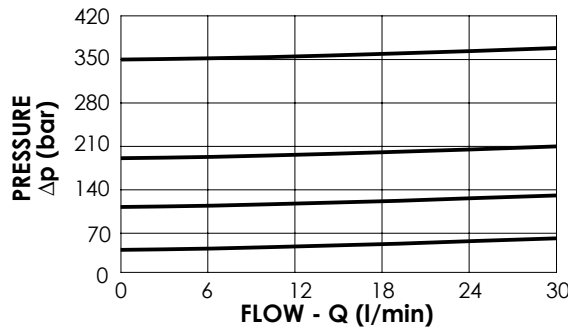

ORDERING CODES

Quick code	Description	Rated flow (l/min)	Standard setting (bar, Q=5 l/min)	Adjustment range (bar)	Pressure increase (bar/turn)	Options
CP000401	CPLN-023-DHNA-CF-008-N500	20	350	150 - 500	150	With Filter
CP000411	CPLN-030-DHNA-HF-008-N420	30	350	250-420	104	With Filter
CP000082	CPLN-030-DHNA-HN-008-N350	30	350	100-350	91	Without Filter
CP000083	CPLN-030-DHNA-HN-008-N200	30	200	50-210	42	Without Filter
CP000084	CPLN-030-DHNA-HN-008-N100	30	100	30-100	20	Without Filter
CP000085	CPLN-030-DHNA-HN-008-N050	30	50	10-50	10	Without Filter

RELIEF VALVE

CPLN-XXX-DHAA

DIRECT ACTING
STABILIZED PISTON
HARDENED SEAT

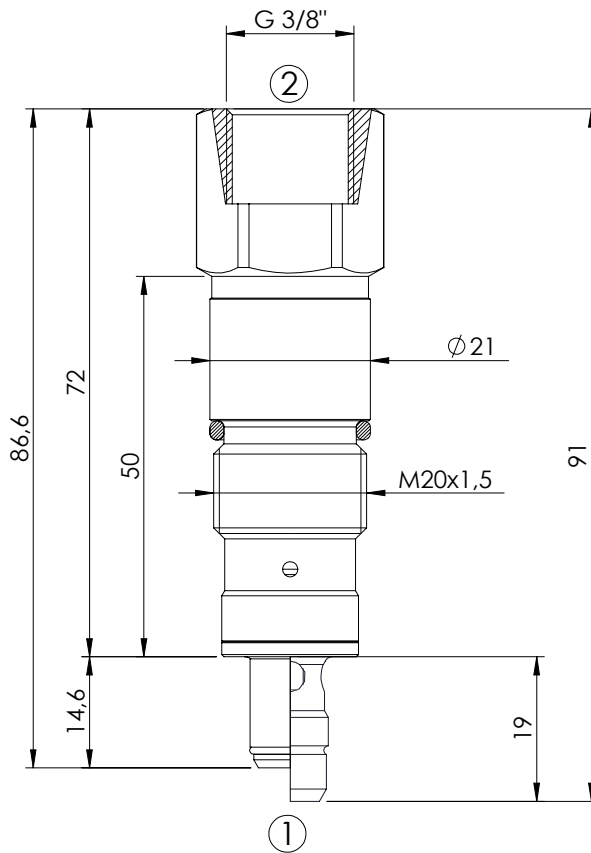
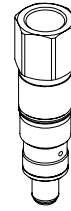

With Filter

Without Filter

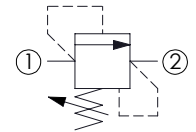
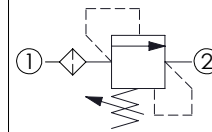

SPECIFICATIONS

Max. operating pressure: 500 bar

Max. operating pressure on T: 350 bar

Rated flow: See table

Cavity: VP000008

Weight: 0,14 kg

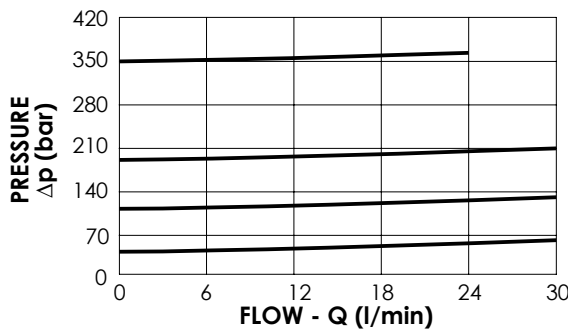

NOTES

Installation torque: 40-45 Nm

ORDERING CODES

Quick code	Description	Rated flow (l/min)	Standard setting (bar, Q=5 l/min)	Adjustment range (bar)	Pressure increase (bar/turn)	Options
CP000266	CPLN-023-DHAA-CF-008-N500	20	350	150-500	167	With Filter
CP000141	CPLN-030-DHAA-GN-008-N350	30	350	100-350	102	Without Filter
CP000190	CPLN-030-DHAA-GN-008-N200	30	200	50-210	46	Without Filter
CP000191	CPLN-030-DHAA-GN-008-N100	30	100	30-100	22	Without Filter
CP000192	CPLN-030-DHAA-GN-008-N050	30	50	10-50	11	Without Filter

RELIEF VALVE IN BODY

KPLN-030-DPNA

DIRECT ACTING
STABILIZED PISTON

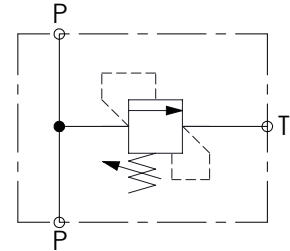
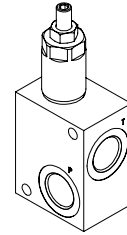
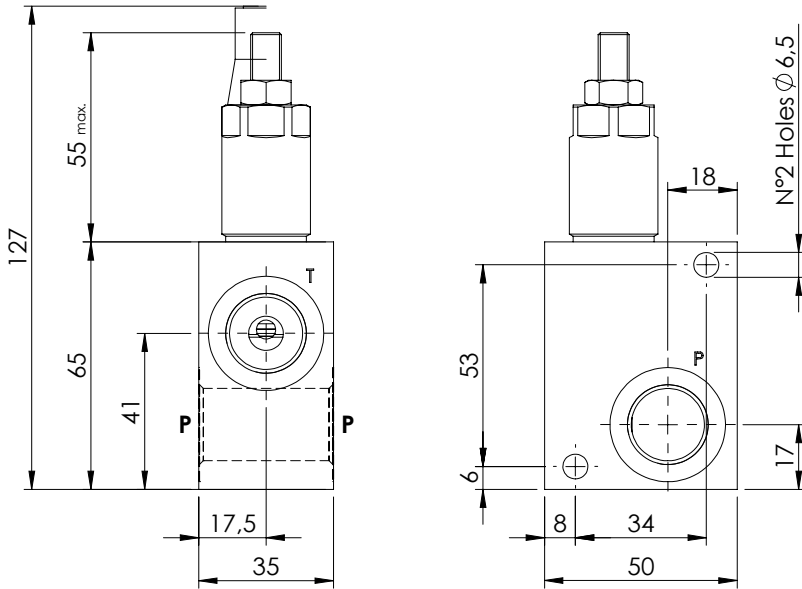

SPECIFICATIONS

Max. operating pressure:	350 bar
Rated flow:	30 l/min
Manifold:	Aluminium
Weight:	0,4 kg

SEALING CAP

Ordering code:
AT000020

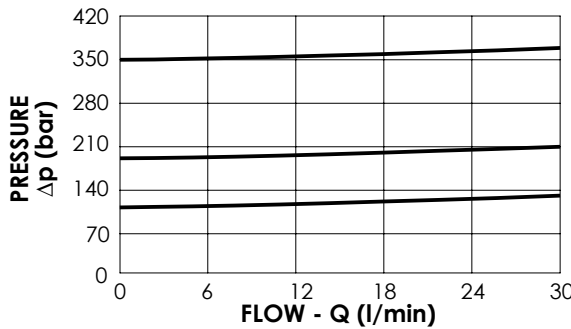
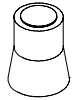

NOTES

*Codes available with steel manifold.

ORDERING CODES

Quick code	Description	Main ports size	Standard setting (bar, Q=5 l/min)	Adjustm. range (bar)	Pressure increase (bar/turn)
KP000006	KPLN-030-DPNA-HN-G12-N350	P,T: G 1/2"	350	100-350	91
KP000005	KPLN-030-DPNA-HN-G12-N200	P,T: G 1/2"	200	50-210	42
KP000004	KPLN-030-DPNA-HN-G12-N100	P,T: G 1/2"	100	30-100	20
KP000003	KPLN-030-DPNA-HN-G38-N350	P,T: G 3/8"	350	100-350	91
KP000002	KPLN-030-DPNA-HN-G38-N200	P,T: G 3/8"	200	50-210	42
KP000001	KPLN-030-DPNA-HN-G38-N100	P,T: G 3/8"	100	30-100	20

RELIEF VALVE

CPLN-080-DPNA

DIRECT ACTING
STABILIZED PISTON

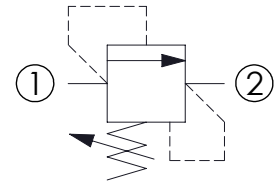
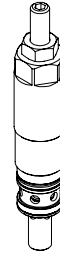
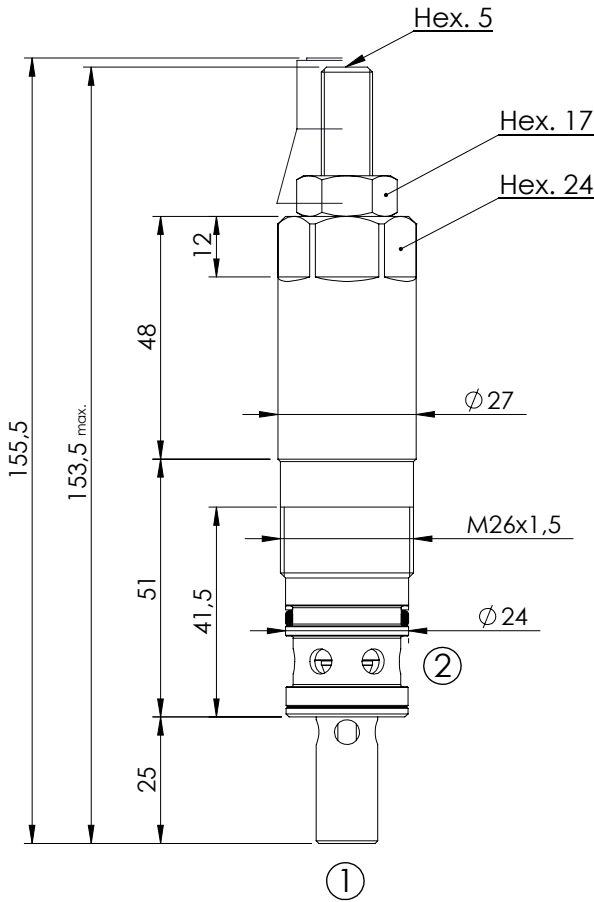

SPECIFICATIONS

Max. operating pressure:	420 bar
Rated flow:	80 l/min
Cavity:	VP000086
Weight:	0,34 kg

SEALING CAP

Ordering code:
AT000021

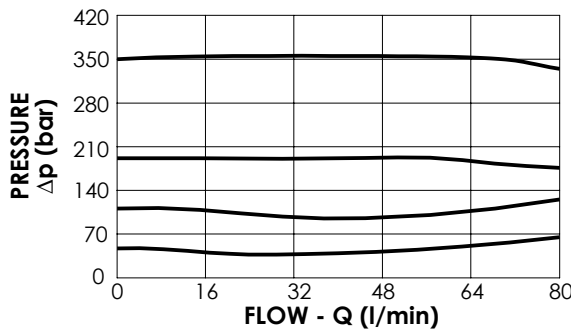
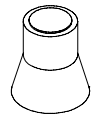

NOTES

Installation torque:	80 - 95 Nm
Seal kit:	RC700086

ORDERING CODES

Quick code	Description	Standard setting (bar, Q=5 l/min)	Adjustment range (bar)	Pressure increase (bar/turn)
CP000180	CPLN-080-DPNA-HN-086-N420	350	150-420	53
CP000026	CPLN-080-DPNA-HN-086-N350	350	100-350	42
CP000076	CPLN-080-DPNA-HN-086-N200	200	60-210	24
CP000077	CPLN-080-DPNA-HN-086-N100	100	25-100	13
CP000099	CPLN-080-DPNA-HN-086-N050	50	5-50	9

RELIEF VALVE IN BODY

KPLN-080-DPNA

**DIRECT ACTING
STABILIZED PISTON**

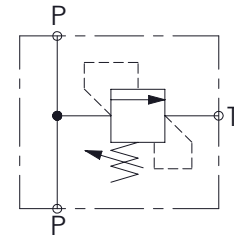
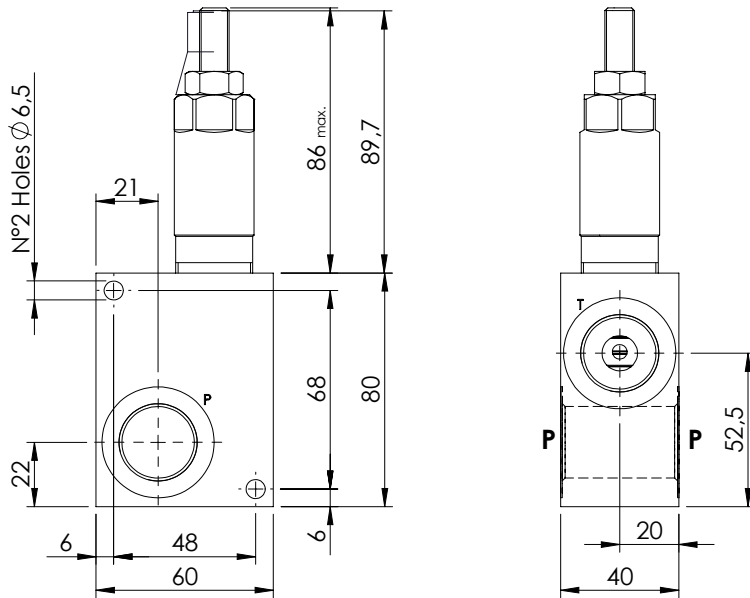
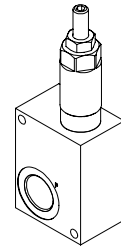

SPECIFICATIONS

Max. operating pressure:	350 bar
Rated flow:	80 l/min
Manifold:	Aluminium
Weight:	0,68 kg

SEALING CAP

Ordering code:
AT000021

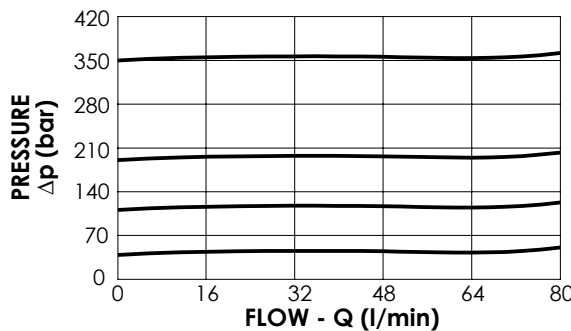
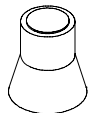

NOTES

*Codes available with steel manifold.

ORDERING CODES

Quick code	Description	Main ports size	Standard setting (bar, Q=5 l/min)	Adjustm. range (bar)	Pressure increase (bar/turn)
KP000018	KPLN-080-DPNA-HN-G34-N350	P,T : G 3/4"	350	100-350	42
KP000070	KPLN-080-DPNA-HN-G34-N200	P,T : G 3/4"	200	60-210	24
KP000069	KPLN-080-DPNA-HN-G34-N100	P,T : G 3/4"	100	25-100	13
KP000098	KPLN-080-DPNA-HN-G34-N050	P,T : G 3/4"	50	5-50	9
KP000016	KPLN-080-DPNA-HN-G12-N350	P,T : G 1/2"	350	100-350	42
KP000090	KPLN-080-DPNA-HN-G12-N200	P,T : G 1/2"	200	60-210	24
KP000091	KPLN-080-DPNA-HN-G12-N100	P,T : G 1/2"	100	25-100	13
KP000099	KPLN-080-DPNA-HN-G12-N050	P,T : G 1/2"	50	5-50	9

RELIEF VALVE

CPLN-120-DPNA

**DIRECT ACTING
POPPET TYPE**

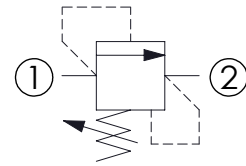
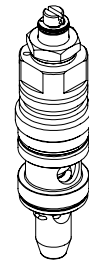
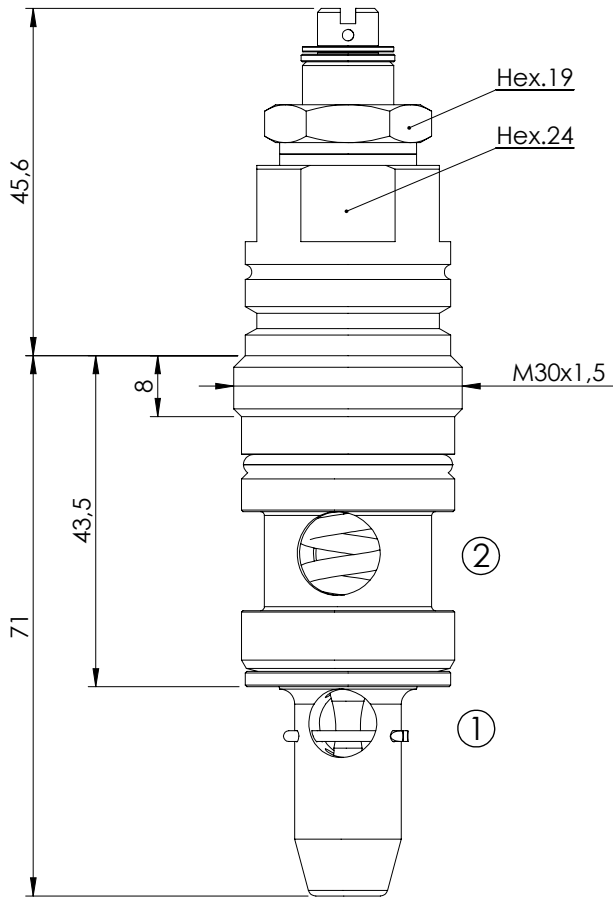

SPECIFICATIONS

Max. operating pressure in line 2: 70 bar

Max. operating pressure in line 1: 350 bar

Rated flow: 120 l/min

Cavity: VP000388

Weight: 0,250 kg

NOTES

Installation torque: 110-120 Nm

Seal kit: RC100388

For lower pressure-range

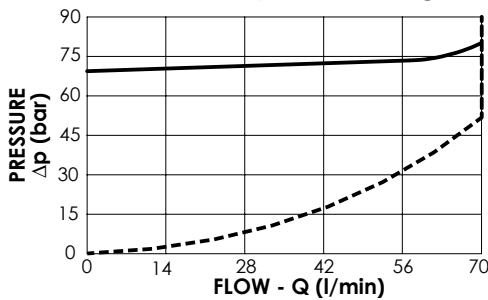

For higher pressure-range

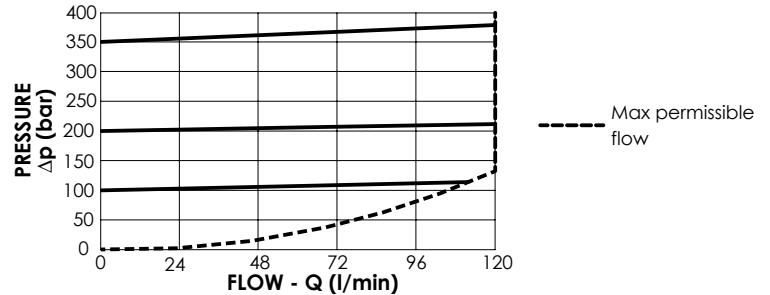

ORDERING CODES

Quick code	Description	Adjustment range (bar)	
CP000276	CPLN-120-DPNA-HN-388-N70	7 - 67	
CP000434	CPLN-120-DPNA-HN-388-N100	40 - 100	
CP000462	CPLN-120-DPNA-HN-388-N200	40 - 200	
CP000463	CPLN-120-DPNA-HN-388-N350	50 - 350	

RELIEF VALVE

CPLT-030-DPNA

DIRECT ACTING
STABILIZED PISTON
COMPENSATED

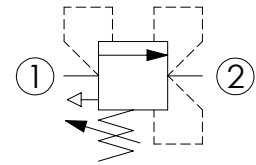
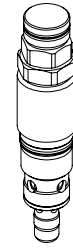
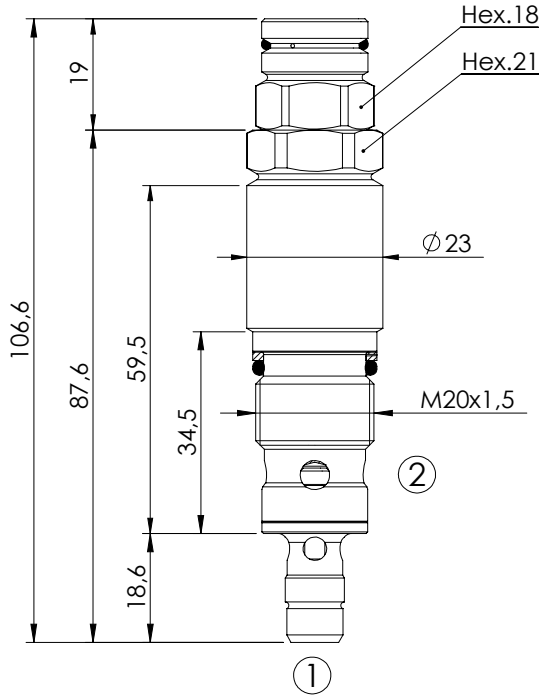

SPECIFICATIONS

Max. operating pressure:	420 bar
Rated flow:	30 l/min
Cavity:	VP000008
Weight:	0,2 kg

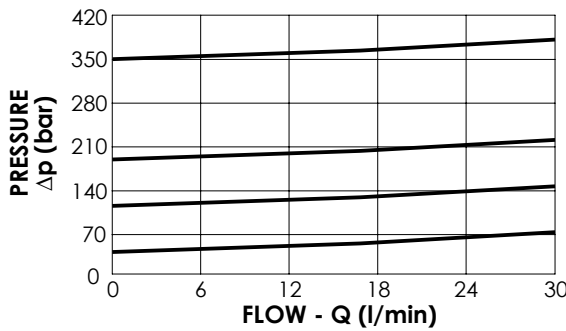

NOTES

Installation torque:	45-50 Nm
Seal kit:	RC700008

ORDERING CODES

Quick code	Description	Standard setting (bar, Q=5 l/min)	Adjustment range (bar)	Pressure increase (bar/turn)
CP000125	CPLT-030-DPNA-HN-008-N420	350	250-420	104
CP000078	CPLT-030-DPNA-HN-008-N350	350	100-350	91
CP000079	CPLT-030-DPNA-HN-008-N200	200	50-210	42
CP000080	CPLT-030-DPNA-HN-008-N100	100	30-100	20
CP000081	CPLT-030-DPNA-HN-008-N050	50	10-50	10

RELIEF VALVE

CPLT-030-DHNA

DIRECT ACTING COMPENSATED
STABILIZED PISTON
HARDENED SEAT

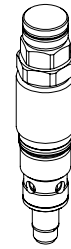
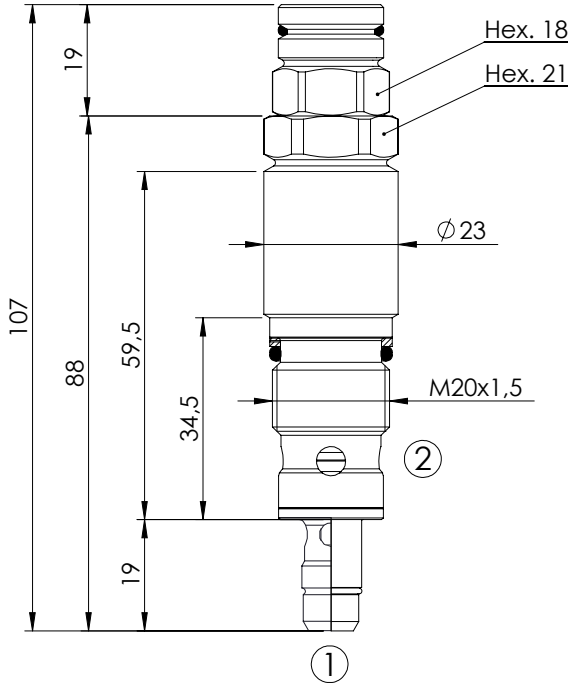

With Filter

Without Filter

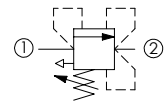
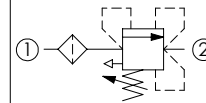

SPECIFICATIONS

Max. operating pressure:	420 bar
Max. operating pressure on T:	350 bar
Rated flow:	30 l/min
Cavity:	VP000008
Weight:	0,2 kg

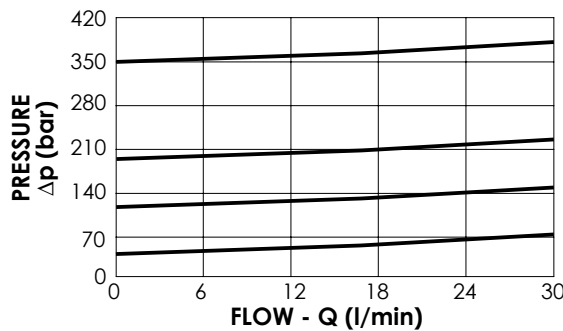

NOTES

Installation torque:	45-50 Nm
Seal kit:	RC700008
Filtration:	300 micron

ORDERING CODES

Quick code	Description	Standard setting (bar, Q=5 l/min)	Adjustment range (bar)	Pressure increase (bar/turn)	Options
CP000410	CPLT-030-DHNA-HF-008-N420	350	250-420	104	With Filter
CP000095	CPLT-030-DHNA-HN-008-N350	350	100-350	91	Without Filter
CP000096	CPLT-030-DHNA-HN-008-N200	200	50-210	42	Without Filter
CP000097	CPLT-030-DHNA-HN-008-N100	100	30-100	20	Without Filter
CP000098	CPLT-030-DHNA-HN-008-N050	50	10-50	10	Without Filter

RELIEF VALVE

CPLT-080-DHNA

**DIRECT ACTING
STABILIZED PISTON
COMPENSATED**

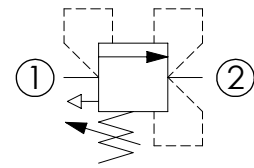
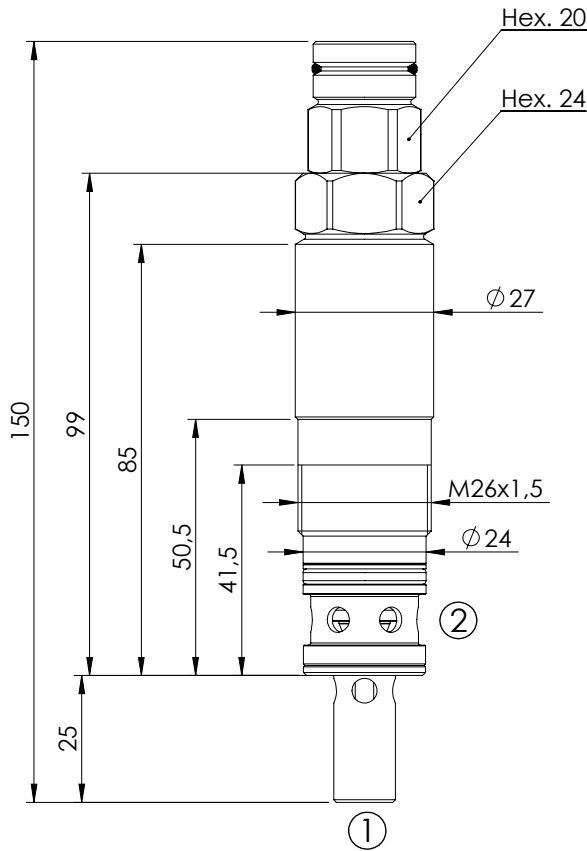

SPECIFICATIONS

Max. operating pressure:	420 bar
Rated flow:	80 l/min
Cavity:	VP000086
Weight:	0,41 kg

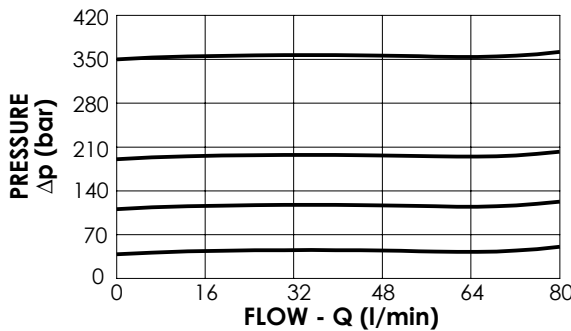

NOTES

Installation torque:	80 - 95 Nm
Seal kit:	RC700086

ORDERING CODES

Quick code	Description	Standard setting (bar, Q=5 l/min)	Adjustment range (bar)	Pressure increase (bar/turn)
CP000181	CPLT-080-DHNA-HN-086-N420	350	150-420	53
CP000130	CPLT-080-DHNA-HN-086-N350	350	100-350	42
CP000142	CPLT-080-DHNA-HN-086-N200	200	60-210	24
CP000143	CPLT-080-DHNA-HN-086-N100	100	25-100	13
CP000144	CPLT-080-DHNA-HN-086-N050	50	5-50	9

RELIEF VALVE

CPLT-080-DHNA

**DIRECT ACTING
STABILIZED PISTON
CHAMBER VENTED**

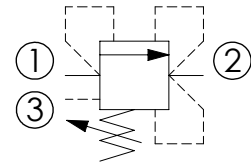
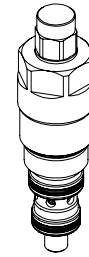
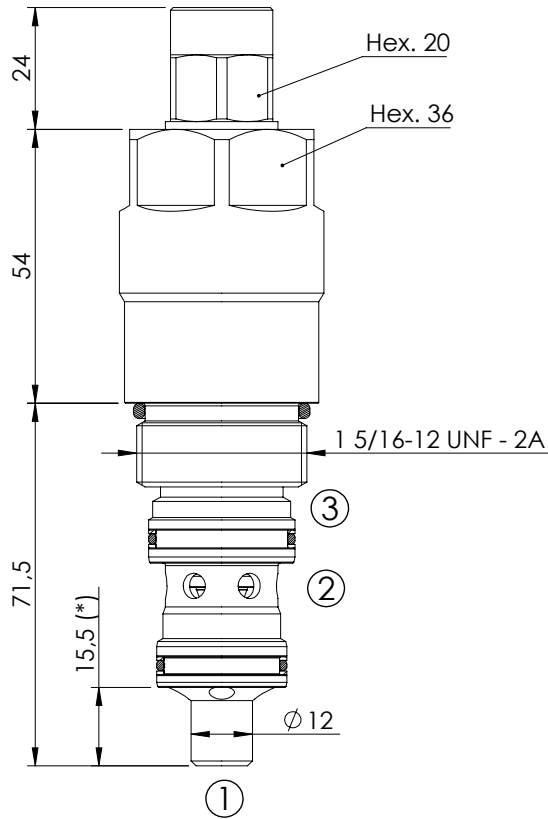

SPECIFICATIONS

Max. operating pressure:	420 bar
Rated flow:	80 l/min
Cavity:	SAE-16-3C
Weight:	0,75 kg

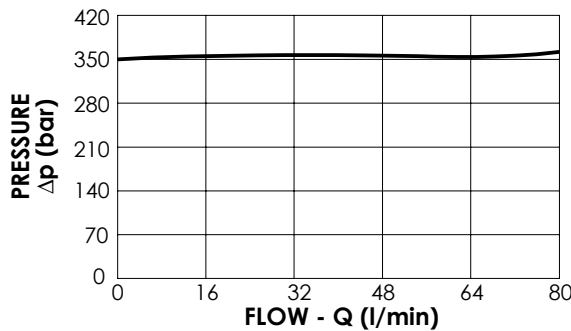

NOTES

Installation torque:	118 - 132 Nm
Seal kit:	RB700089

(*): The cartridge exceed overall dimension of the standard cavity into port 1.

ORDERING CODES

Quick code	Description	Standard setting (bar, Q=5 l/min)	Adjustment range (bar)	Pressure increase (bar/turn)
CP000171	CPLT-080-DHNA-HN-S16-N420	350	150-420	53

RELIEF VALVE

CPLN-040-DHGD

DIFFERENTIAL AREA
POPPET TYPE

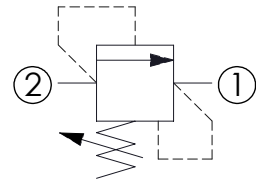
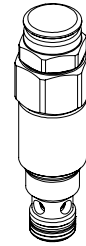
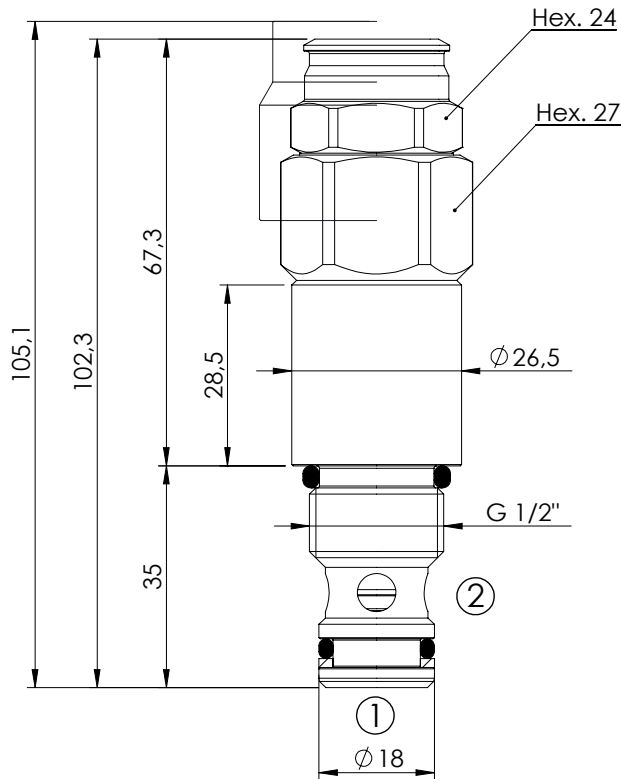

SPECIFICATIONS

Max. operating pressure:	350 bar
Rated flow:	40 l/min
Cavity:	VP000080
Weight:	0,31 kg

SEALING CAP

Ordering code:
PT000258

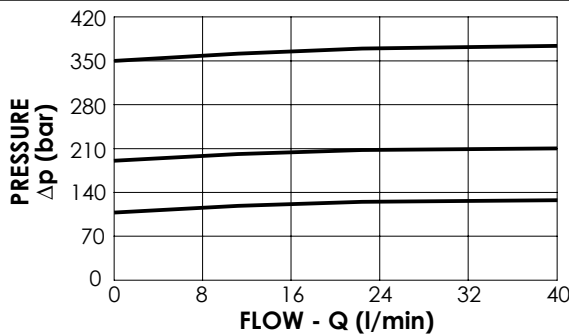
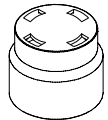

NOTES

Installation torque:	95 - 105 Nm
Seal kit:	RC900080

ORDERING CODES

Quick code	Description	Standard setting (bar, Q=5 l/min)	Adjustment range (bar)	Pressure increase (bar/turn)
CP000036	CPLN-040-DHGD-HN-080-N350	350	100-350	119
CP000088	CPLN-040-DHGD-HN-080-N200	200	50-210	63
CP000223	CPLN-040-DHGD-HN-080-N100	100	30-100	30

RELIEF VALVE

CPLN-090-DHGA

**DIRECT ACTING
STABILIZED PISTON**

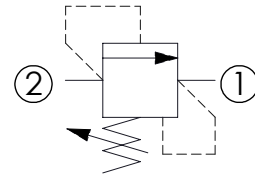
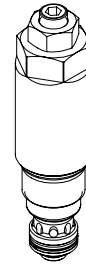
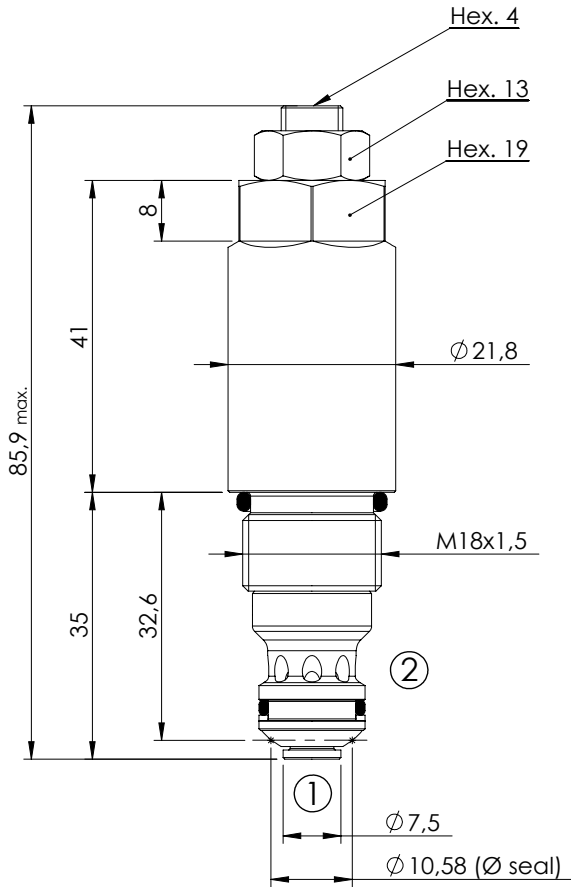

SPECIFICATIONS

Max. operating pressure:	380 bar
Rated flow:	90 l/min
Cavity:	VP000249
Weight:	0,15 kg

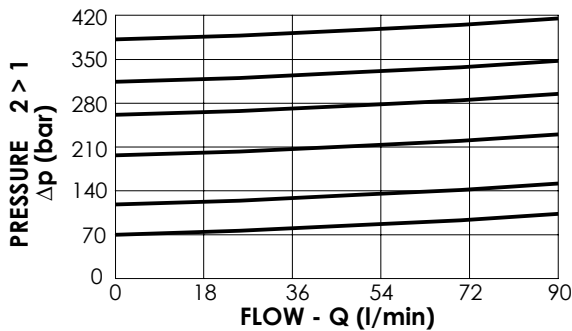

NOTES

Installation torque:	45 - 50 Nm
Seal kit:	RC900249

ORDERING CODES

Quick code	Description	Standard setting (bar, Q=5 l/min)	Adjustment range (bar)	Pressure increase (bar/turn)
CP000105	CPLN-090-DHGA-HN-249-N380	380	320 - 380	101
CP000101	CPLN-090-DHGA-HN-249-N320	320	270 - 320	67
CP000104	CPLN-090-DHGA-HN-249-N270	270	200 - 270	44
CP000103	CPLN-090-DHGA-HN-249-N200	200	120 - 200	30
CP000102	CPLN-090-DHGA-HN-249-N120	120	70 - 120	18
CP000120	CPLN-090-DHGA-HN-249-N070	70	10 - 70	8

RELIEF VALVE WITH REVERSE FREE FLOW

CPAN-090-DHGA

DIRECT ACTING
STABILIZED PISTON

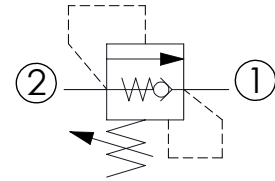
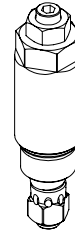
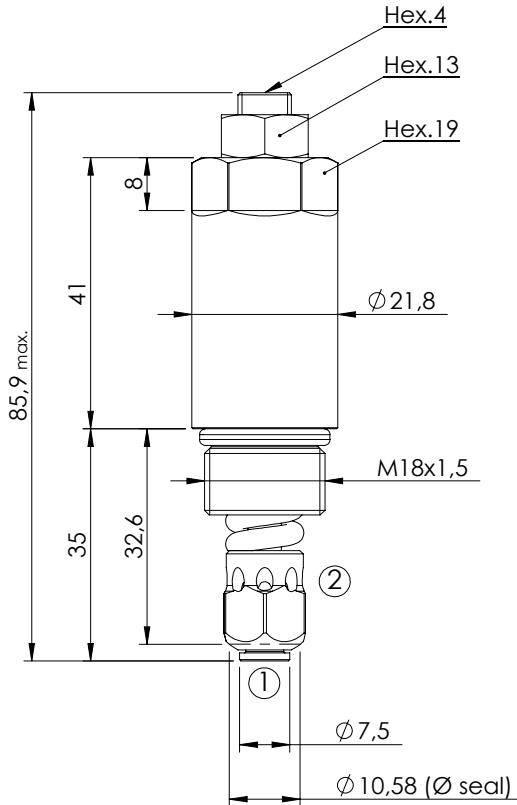

SPECIFICATIONS

Max. operating pressure:	380 bar
Rated flow:	90 l/min
Cavity:	VP000249
Weight:	0,15 kg

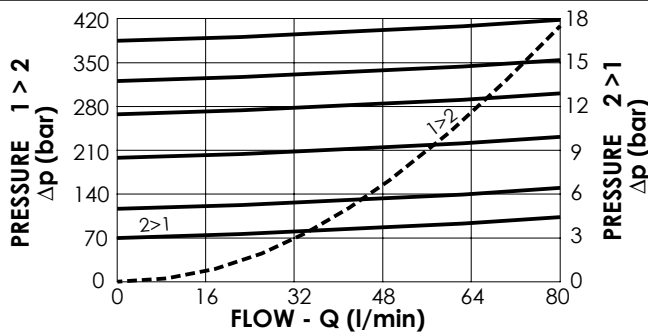

NOTES

Installation torque:	40 - 45 Nm
Seal kit:	RC900249

ORDERING CODES

Quick code	Description	Standard setting (bar, Q=5 l/min)	Adjustment range (bar)	Pressure increase (bar/turn)
CP000114	CPAN-090-DHGA-HN-249-N380	380	320 - 380	101
CP000113	CPAN-090-DHGA-HN-249-N320	320	270 - 320	67
CP000109	CPAN-090-DHGA-HN-249-N270	270	200 - 270	44
CP000112	CPAN-090-DHGA-HN-249-N200	200	120 - 200	30
CP000111	CPAN-090-DHGA-HN-249-N120	120	70 - 120	18
CP000122	CPAN-090-DHGA-HN-249-N070	70	10 - 70	8

RELIEF VALVE

CPLN-150-DHGD

DIFFERENTIAL AREA
POPPET TYPE

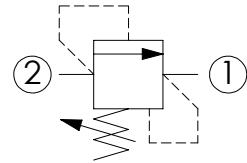
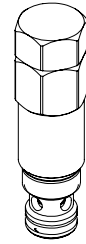
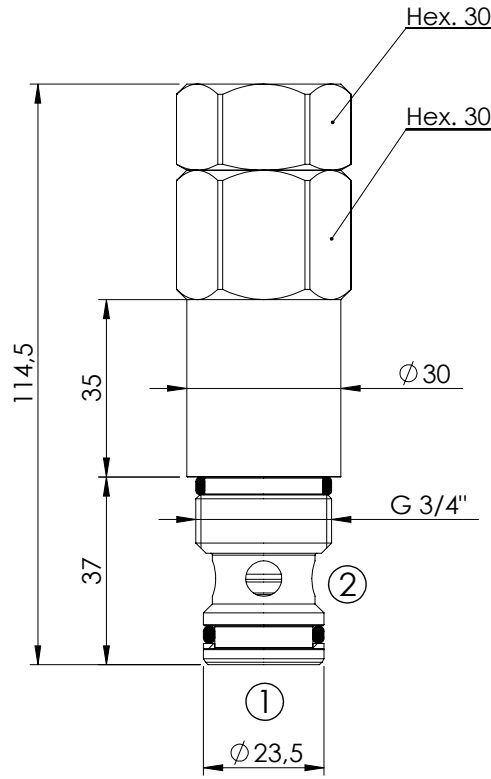

SPECIFICATIONS

Max. operating pressure:	350 bar
Rated flow:	150 l/min
Cavity:	VP000070
Weight:	0,48 kg

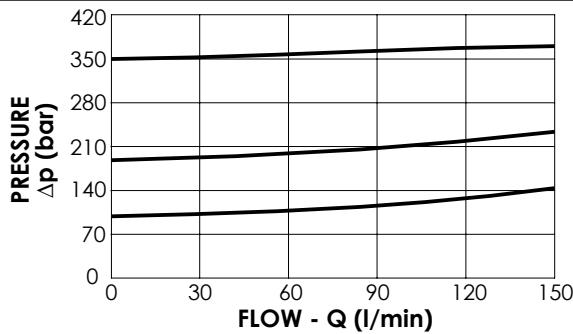

NOTES

Installation torque:	110 - 130 Nm
Seal kit:	RC700070

ORDERING CODES

Quick code	Description	Standard setting (bar, Q=5 l/min)	Adjustment range (bar)	Pressure increase (bar/turn)
CP000022	CPLN-150-DHGD-HN-070-N350	350	130-350	111
CP000018	CPLN-150-DHGD-HN-070-N200	200	70-210	73
CP000021	CPLN-150-DHGD-HN-070-N100	100	30-100	32

RELIEF VALVE IN BODY

KPLN-150-DHGD

DIFFERENTIAL AREA
POPPET TYPE

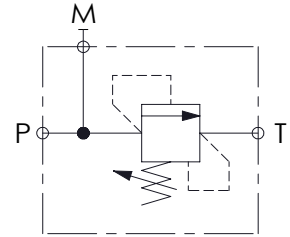
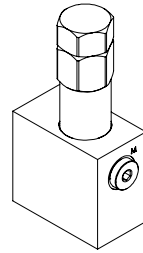
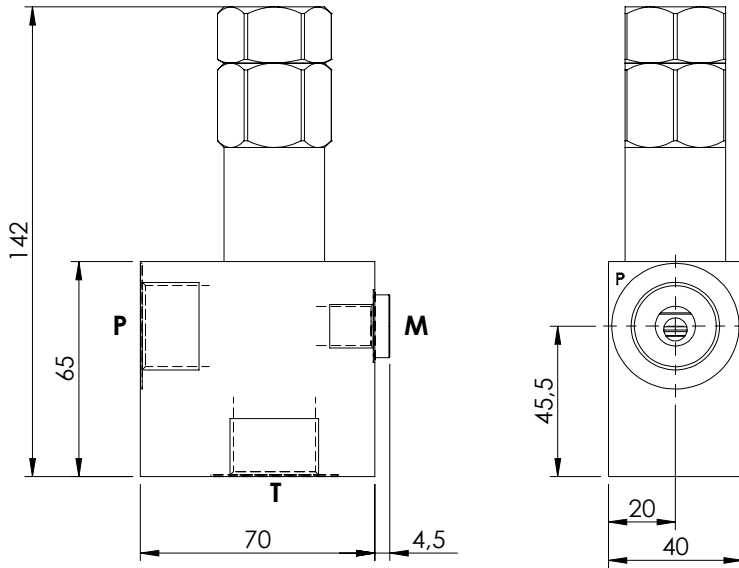
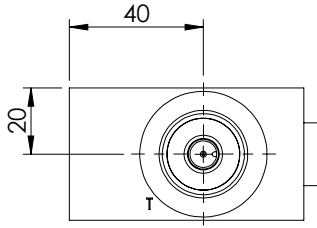

SPECIFICATIONS

Max. operating pressure:	350 bar
Rated flow:	150 l/min
Manifold:	Aluminium
Weight:	0,85 kg

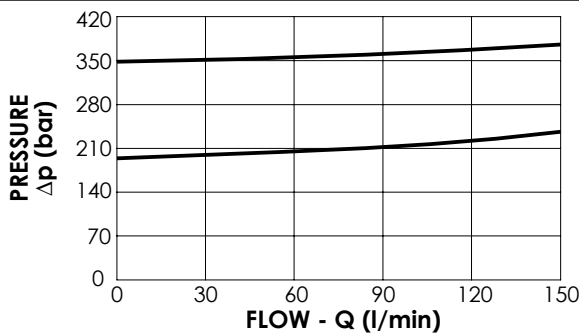

ORDERING CODES

Quick code	Description	Main ports size	Standard setting (bar, Q=5 l/min)	Adjustm. range (bar)	Pressure increase (bar/turn)
KP000028	KPLN-150-DHGD-HN-G34-N350	P,T: G 3/4" M: G 1/4"	350	130-350	111
KP000057	KPLN-150-DHGD-HN-G34-N200	P,T: G 3/4" M: G 1/4"	200	70-210	73
KP000020	KPLN-150-DHGD-HN-G12-N350	P,T: G 1/2" M: G 1/4"	350	130-350	111
KP000058	KPLN-150-DHGD-HN-G12-N200	P,T: G 1/2" M: G 1/4"	200	70-210	73

RELIEF VALVE

CPLN-160-DHGA

**DIRECT ACTING
STABILIZED PISTON**

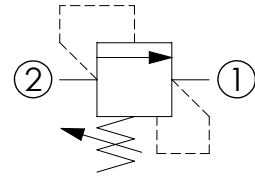
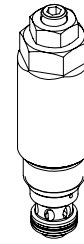
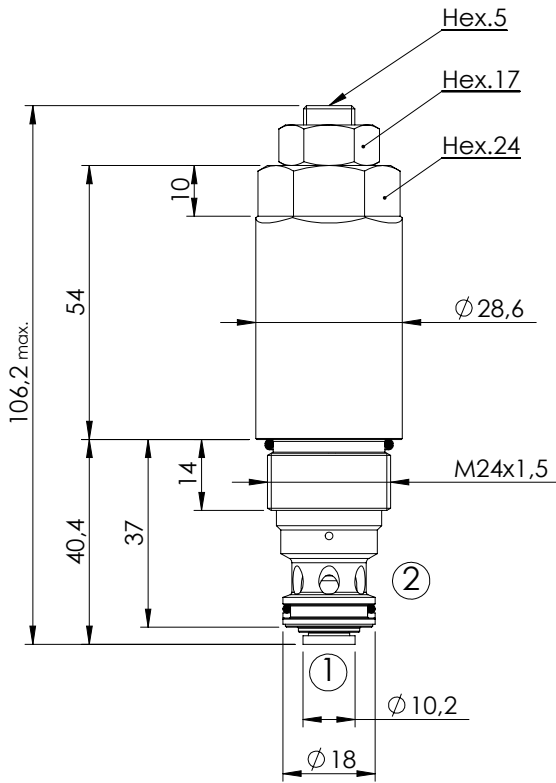

SPECIFICATIONS

Max. operating pressure:	400 bar
Rated flow:	160 l/min
Cavity:	VP000250
Weight:	0,33 kg

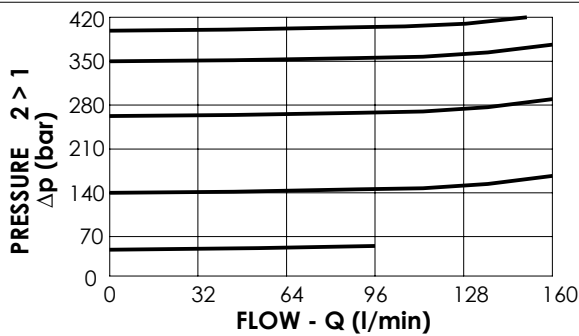

NOTES

Installation torque:	45 - 50 Nm
Seal kit:	RC900250

ORDERING CODES

Quick code	Description	Standard setting (bar, Q=5 l/min)	Adjustment range (bar)	Pressure increase (bar/turn)
CP000108	CPLN-160-DHGA-HN-250-N400	400	350 - 400	72
CP000107	CPLN-160-DHGA-HN-250-N350	350	270 - 350	58
CP000100	CPLN-160-DHGA-HN-250-N270	270	140 - 270	49
CP000106	CPLN-160-DHGA-HN-250-N140	140	90 - 140	36
CP000121	CPLN-160-DHGA-HN-250-N090	90	50 - 90	13

RELIEF VALVE WITH REVERSE FREE FLOW

CPAN-160-DHGA

DIRECT ACTING
STABILIZED PISTON

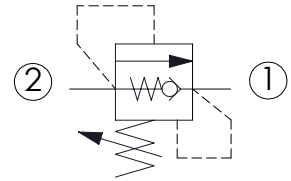
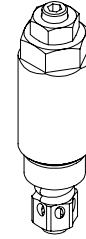
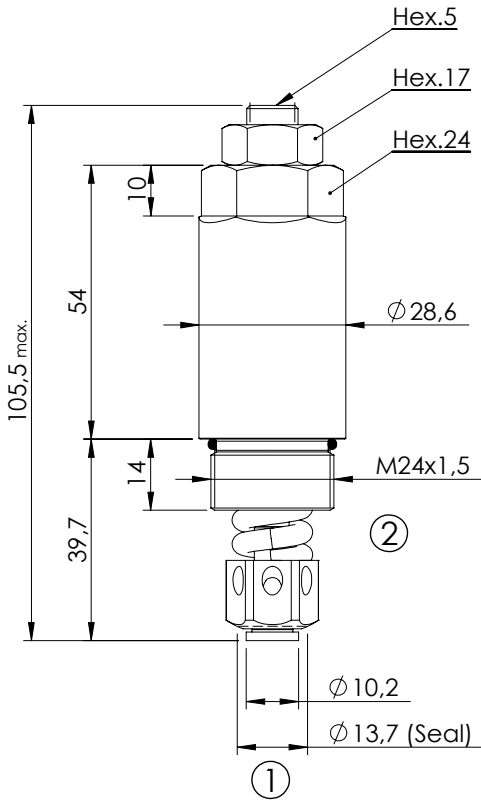

SPECIFICATIONS

Max. operating pressure:	400 bar
Rated flow:	160 l/min
Cavity:	VP000250
Weight:	0,32 kg

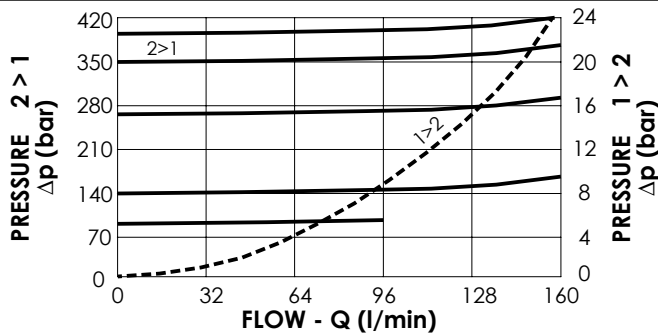

NOTES

Installation torque:	45 - 50 Nm
Seal kit:	RC900250

ORDERING CODES

Quick code	Description	Standard setting (bar, Q=5 l/min)	Adjustment range (bar)	Pressure increase (bar/turn)
CP000117	CPAN-160-DHGA-HN-250-N400	400	350 - 400	72
CP000116	CPAN-160-DHGA-HN-250-N350	350	270 - 350	58
CP000110	CPAN-160-DHGA-HN-250-N270	270	140 - 270	49
CP000115	CPAN-160-DHGA-HN-250-N140	140	90 - 140	36
CP000123	CPAN-160-DHGA-HN-250-N090	90	50 - 90	13

RELIEF VALVE

CPLN-250-DHGD

DIFFERENTIAL AREA
POPPET TYPE

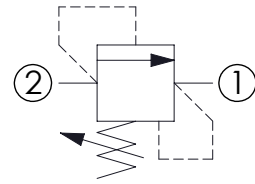
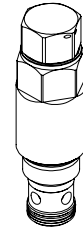
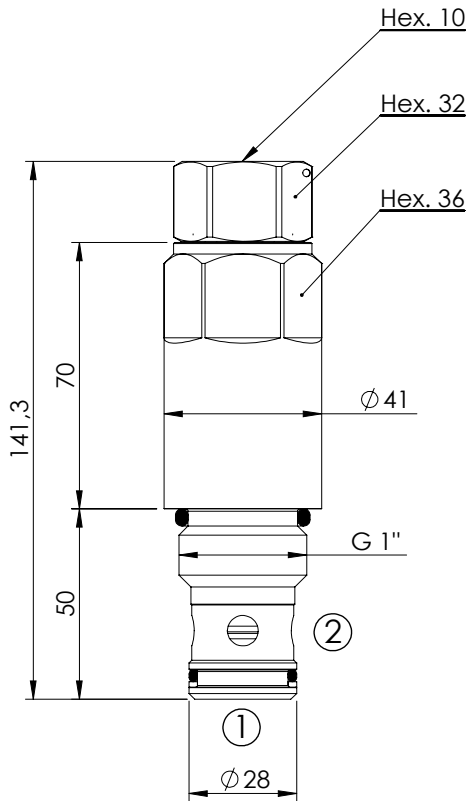

SPECIFICATIONS

Max. operating pressure:	350 bar
Rated flow:	250 l/min
Cavity:	VP000154
Weight:	0,9 kg

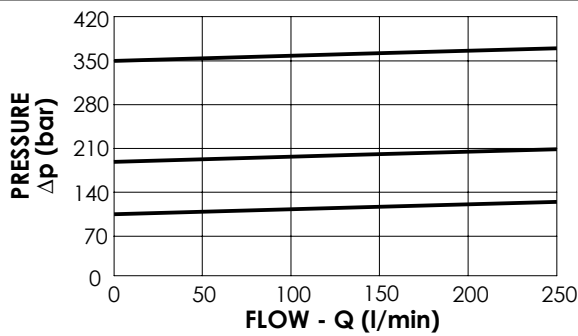

NOTES

Installation torque:	230 - 250 Nm
Seal kit:	RC900154

ORDERING CODES

Quick code	Description	Standard setting (bar, Q=5 l/min)	Adjustment range (bar)	Pressure increase (bar/turn)
CP000046	CPLN-250-DHGD-HN-154-N350	350	120-350	65
CP000119	CPLN-250-DHGD-HN-154-N200	200	50-200	38
CP000224	CPLN-250-DHGD-HN-154-N100	100	20-100	19

RELIEF VALVE

KPLN-250-DHGD

DIFFERENTIAL AREA
POPPET TYPE

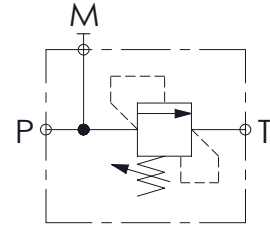
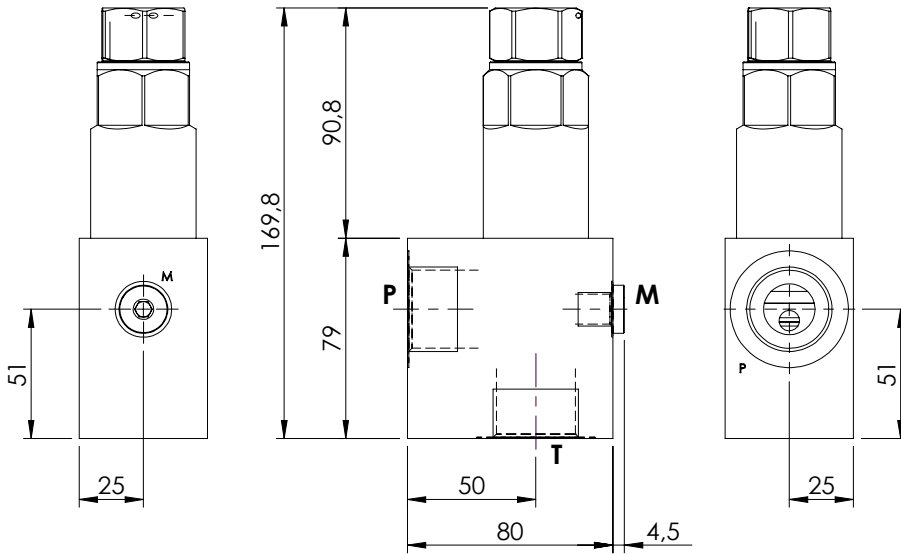
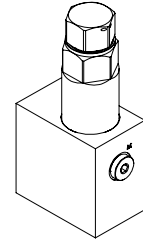
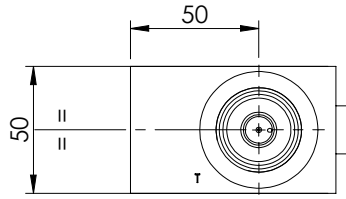

SPECIFICATIONS

Max. operating pressure:	350 bar
Rated flow:	250 l/min
Manifold:	Steel
Weight:	2,73 kg

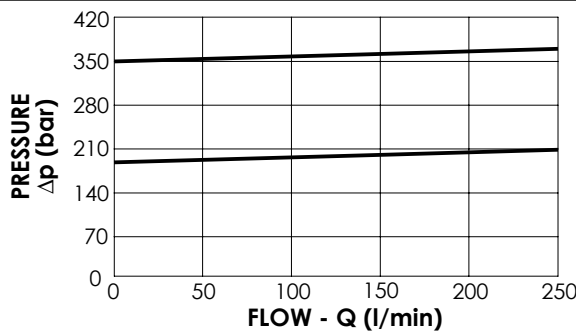

ORDERING CODES

Quick code	Description	Main ports size	Standard setting (bar, Q=5 l/min)	Adjustm. range (bar)	Pressure increase (bar/turn)
KP000068	KPLN-250-DHGD-HN-G10-N350	P,T: G 1" ; M: G 1/4"	350	120-350	65
KP000103	KPLN-250-DHGD-HN-G10-N200	P,T: G 1" ; M: G 1/4"	200	50-200	38

RELIEF VALVE

CPLN-120-PSNA

PILOT OPERATED
SPOOL TYPE

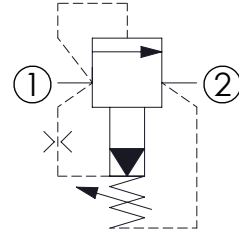
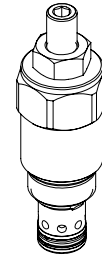
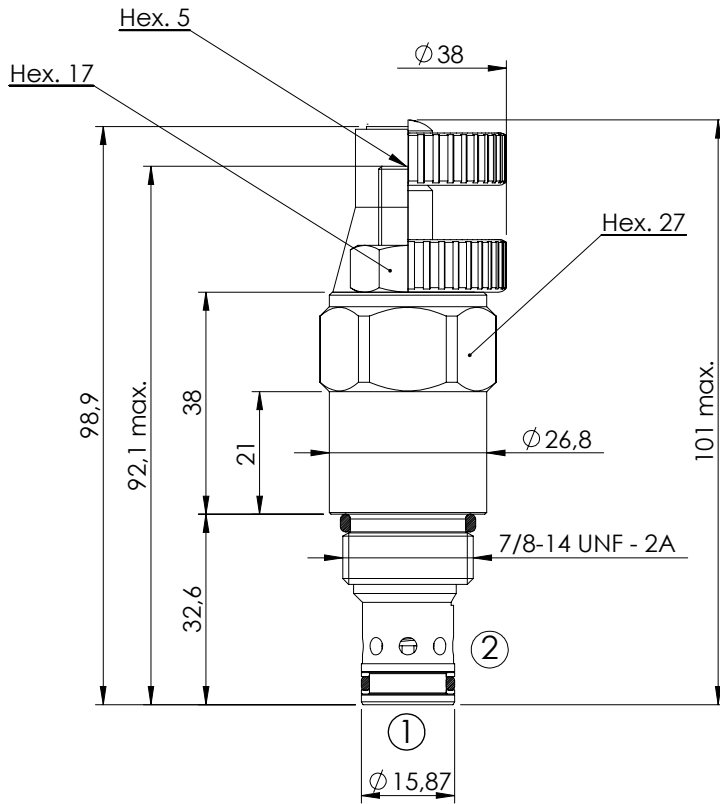

SPECIFICATIONS

Max. operating pressure:	350 bar
Rated flow:	120 l/min
Cavity:	SAE-10-2N
Weight:	0,24 kg
Installation torque:	55 - 62 Nm
Leakage:	200 cm ³ @ 200 bar
Seal kit:	RB700082

SEALING CAP

Ordering code:
AT000022



OPTIONS

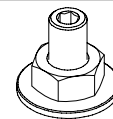

Adjustment
with Screw

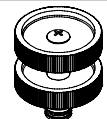

Adjustment
with Handknob

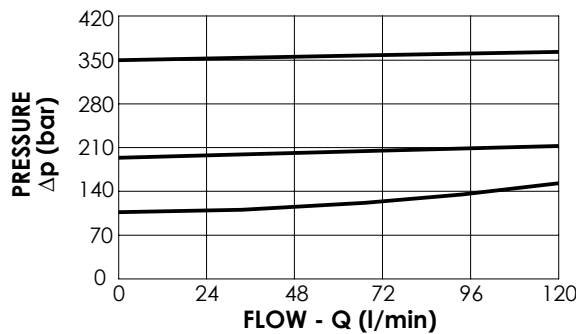

ORDERING CODES

Quick code	Description	Standard setting (bar, Q=5 l/min)	Adjust. range (bar)	Pressure increase (bar/turn)	Option
CP000009	CPLN-120-PSNA-HN-S10-N350	350	140-350	114	Adjustment with Screw
CP000060	CPLN-120-PSNA-HN-S10-N200	200	70-210	69	Adjustment with Screw
CP000059	CPLN-120-PSNA-HN-S10-N100	100	35-120	37	Adjustment with Screw
CP000064	CPLN-120-PSNA-VN-S10-N350	350	140-350	114	Adjustment with Handknob
CP000065	CPLN-120-PSNA-VN-S10-N200	200	70-210	69	Adjustment with Handknob
CP000066	CPLN-120-PSNA-VN-S10-N100	100	35-120	37	Adjustment with Handknob

RELIEF VALVE IN BODY

KPLN-120-PSNA

PILOT OPERATED
SPOOL TYPE

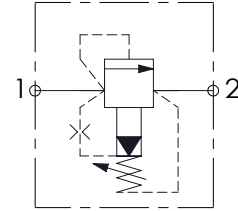
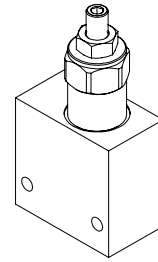
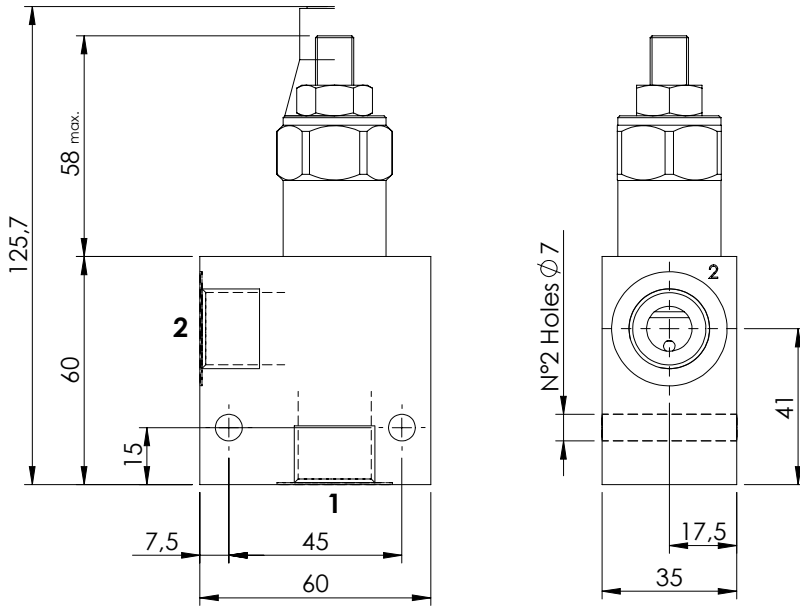
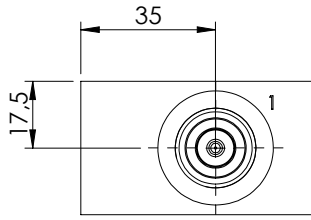

SPECIFICATIONS

Max. operating pressure:	350 bar
Rated flow:	120 l/min
Manifold:	Aluminium
Weight:	0,49 kg
Leakage:	200 cm ³ @ 200 bar

SEALING CAP

Ordering code:
AT000022

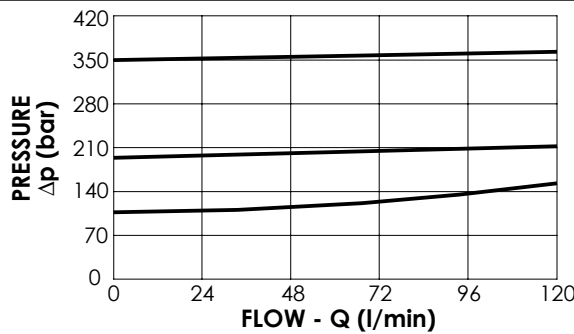
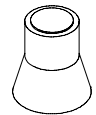

ORDERING CODES

Quick code	Description	Main ports size	Standard setting (bar, Q=5 l/min)	Adjustm. range (bar)	Pressure increase (bar/turn)
KP000014	KPLN-120-PSNA-HN-G12-N350	P,T : G1/2"	350	140-350	114
KP000048	KPLN-120-PSNA-HN-G12-N200	P,T : G1/2"	200	70-210	69
KP000047	KPLN-120-PSNA-HN-G12-N100	P,T : G1/2"	100	35-120	37
KP000096	KPLN-120-PSNA-HN-G34-N350	P,T : G3/4"	350	140-350	114
KP000159	KPLN-120-PSNA-HN-G34-N200	P,T : G3/4"	200	70-210	69
KP000160	KPLN-120-PSNA-HN-G34-N100	P,T : G3/4"	100	35-120	37

RELIEF VALVE

CPLN-300-PSNA

PILOT OPERATED
SPOOL TYPE

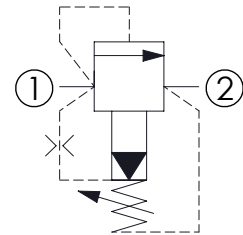
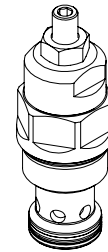
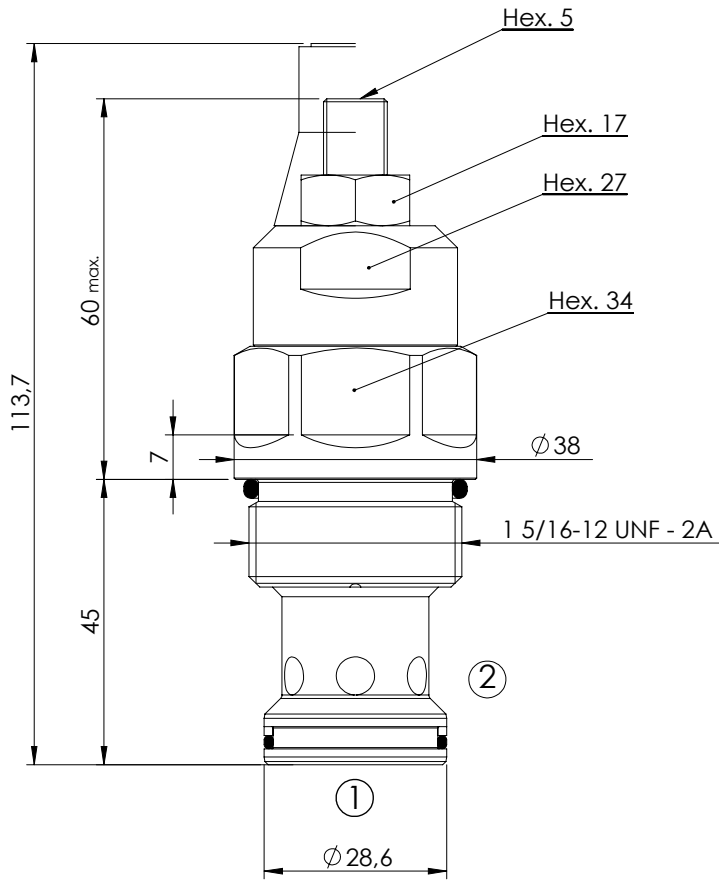

SPECIFICATIONS

Max. operating pressure:	350 bar
Rated flow:	300 l/min
Cavity:	SAE-16-2N
Weight:	0,5 kg
Leakage:	350 cm ³ @ 200 bar

SEALING CAP

Ordering code:
AT000022

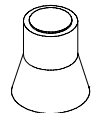

NOTES

Installation torque:	150 - 180 Nm
Seal kit:	RA700084

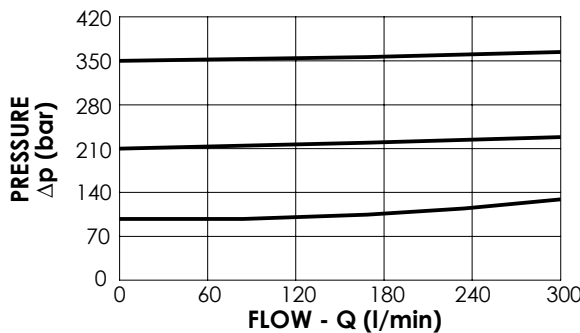

ORDERING CODES

Quick code	Description	Standard setting (bar, Q=5 l/min)	Adjustment range (bar)	Pressure increase (bar/turn)
CP000188	CPLN-300-PSNA-HN-S16-N350	350	140-350	114
CP000177	CPLN-300-PSNA-HN-S16-N200	200	70-210	69
CP000178	CPLN-300-PSNA-HN-S16-N100	100	35-120	37

RELIEF VALVE

CPLN-500-PHNA

PILOTED OPERATED
SPOOL TYPE

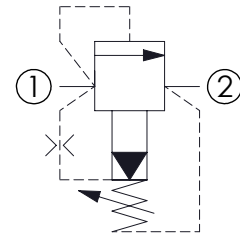
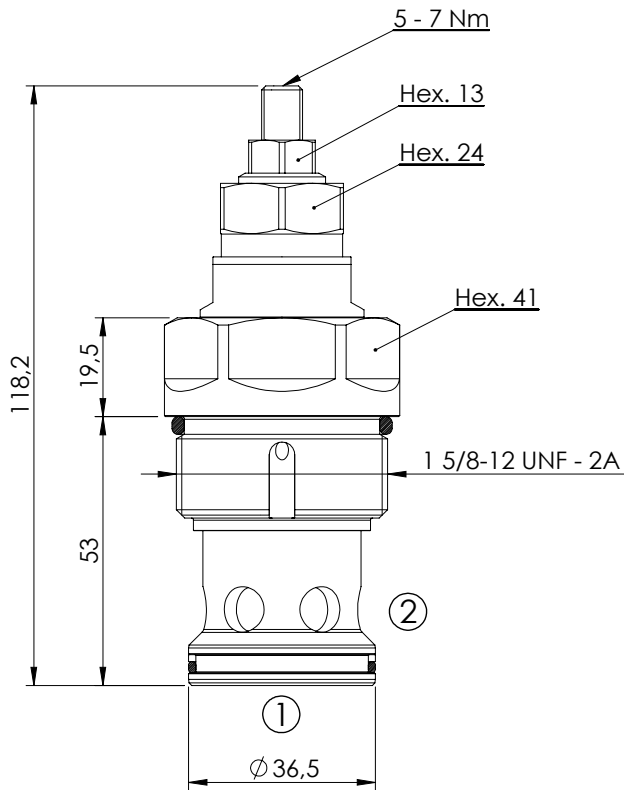
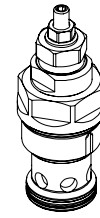

SPECIFICATIONS

Max. operating pressure:	350 bar
Rated flow:	500 l/min
Cavity:	SAE-20-2N
Weight:	0,7 kg
Installation torque:	230 - 250 Nm
Max. int. leakage:	400 cm ³ /min (@46 cSt)
Seal kit:	RA900085

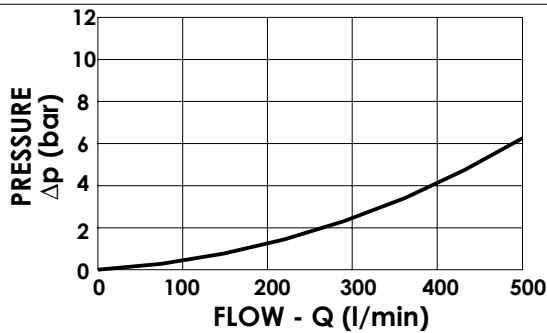

SEALING CAP

Ordering code:
AT000020

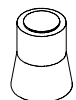

ORDERING CODES

Quick code	Description	Standard setting (bar, Q=5 l/min)	Adjustment range (bar)	Pressure increase (bar/turn)
CP000407	CPLN-500-PHNA-SN-S20-N350	350	140-350	142
CP000408	CPLN-500-PHNA-SN-S20-N200	200	90-210	87
CP000409	CPLN-500-PHNA-SN-S20-N100	100	35-110	47

RELIEF VALVE

CPLT-120-PSNA

PILOT OPERATED
SPOOL TYPE
COMPENSATED

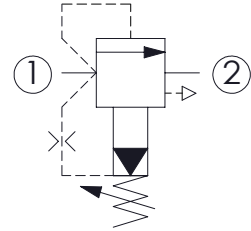
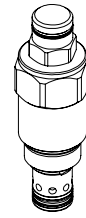
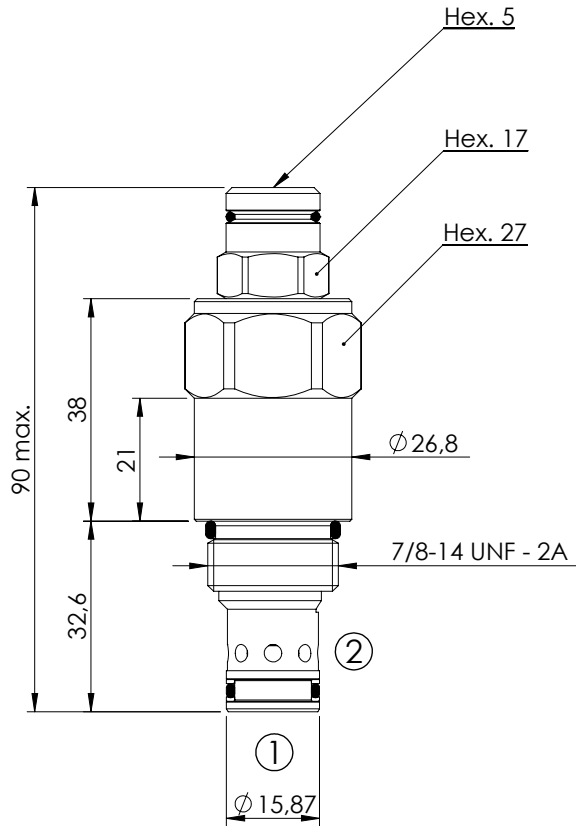

SPECIFICATIONS

Max. operating pressure:	350 bar
Rated flow:	120 l/min
Cavity:	SAE-10-2N
Weight:	0,25 kg
Leakage:	200 cm ³ @ 200 bar

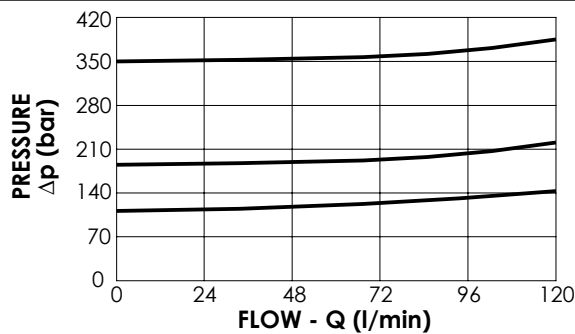

NOTES

Installation torque:	55 - 62 Nm
Seal kit:	RB700082

ORDERING CODES

Quick code	Description	Standard setting (bar, Q=5 l/min)	Adjustment range (bar)	Pressure increase (bar/turn)
CP000070	CPLT-120-PSNA-HN-S10-N350	350	140-350	114
CP000071	CPLT-120-PSNA-HN-S10-N200	200	70-210	69
CP000072	CPLT-120-PSNA-HN-S10-N100	100	35-120	37

RELIEF VALVE

CPLV-120-PSNA

PILOT OPERATED
SPOOL TYPE
SEPARATE TANK LINE

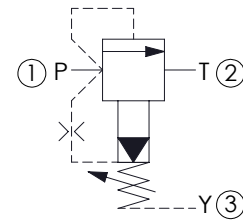
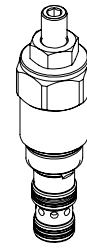
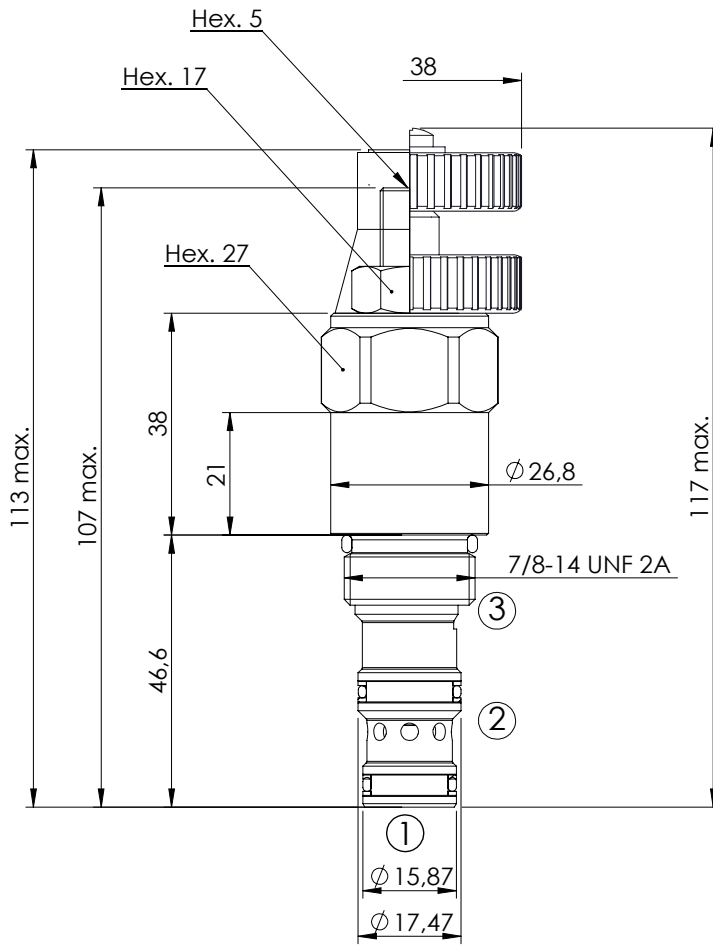

SPECIFICATIONS

Max. operating pressure:	350 bar
Rated flow:	120 l/min
Cavity:	SAE-10-3N
Weight:	0,26 kg
Installation torque:	55 - 62 Nm
Leakage:	200 cm ³ @ 200 bar (1>2)
Seal kit:	RB700092

SEALING CAP

Ordering code:
AT000022



OPTIONS

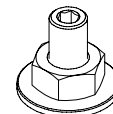

Adjustment
with Screw

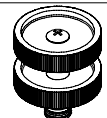

Adjustment
with Handknob

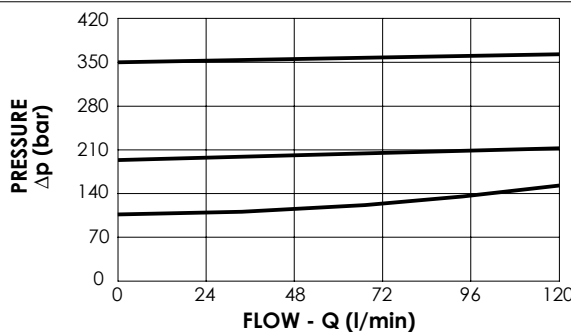

ORDERING CODES

Quick code	Description	Standard setting (bar, Q=5 l/min)	Adjust. range (bar)	Pressure increase (bar/turn)	Option
CP000228	CPLV-120-PSNA-HN-S10-N350	350	140-350	114	Adjustment with Screw
CP000427	CPLV-120-PSNA-HN-S10-N200	200	70-210	69	Adjustment with Screw
CP000428	CPLV-120-PSNA-HN-S10-N100	100	35-120	37	Adjustment with Screw
CP000429	CPLV-120-PSNA-VN-S10-N350	350	140-350	114	Adjustment with Handknob
CP000430	CPLV-120-PSNA-VN-S10-N200	200	70-210	69	Adjustment with Handknob
CP000431	CPLV-120-PSNA-VN-S10-N100	100	35-120	37	Adjustment with Handknob

RELIEF VALVE

CPSK-001-PPNA

DIRECT ACTING
POPET TYPE
KICK DOWN TYPE

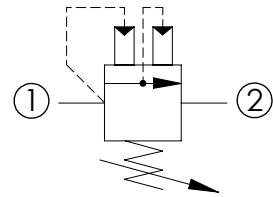
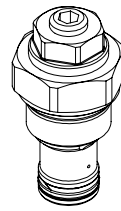
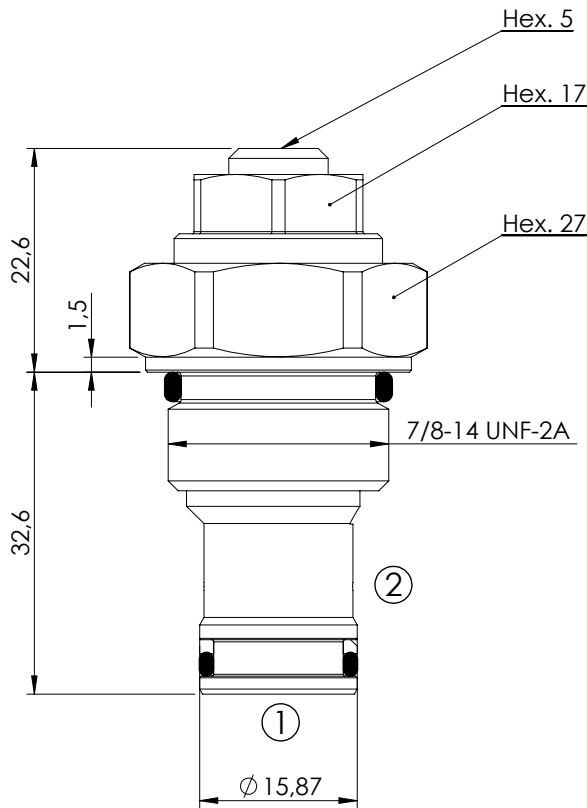

SPECIFICATIONS

Max. operating pressure:	350 bar
Rated flow:	1 l/min
Cavity:	SAE-10-2N
Weight:	0,13 kg

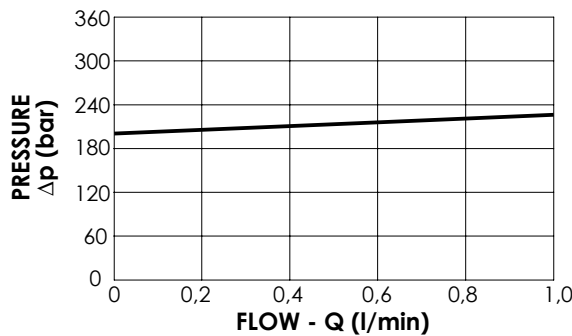

NOTES

Installation torque:	55 - 62 Nm
Seal kit:	RA700082

When the pressure exceeds the setting of the valve the poppet opens and unload the system to 10 bar. The valve closes when the flow is reduced to 0 l/min.

ORDERING CODES

Quick code	Description	Standard setting (bar, cracking press.)	Adjustment range (bar)	Pressure increase (bar/turn)
CP000227	CPSK-001-PPNA-SN-S10-N350	175	140-350	70,5



ATLANTIC
Fluid Tech

SECTION 10

Check and
Metering
Valves



1800-OILSOL
1800-645765

<https://oilsolutions.com.au/>

sales@oilsolutions.com.au

SECTION 10

CHECK AND METERING VALVES



Hydraulic scheme	Valve description	Valve type	Rated flow (l/min)	Max. pressure (bar)	Installation	Main port size or cavity type	Page
	MLST-040-ALGR	Right version	40	420	In line	G 3/8"	10.01.010
	MLST-040-ALGL	Left version	40	420	In line	G 3/8"	10.01.020
	MLST-100-ALGR	Right version	100	420	In line	G 1/2"	10.01.030
	MLST-100-ALGL	Left version	100	420	In line	G 1/2"	10.01.040
	MLST-150-ALGR	Right version	150	420	In line	G 3/4"	10.01.050
	MLST-150-ALGL	Left version	150	420	In line	G 3/4"	10.01.060
	MLST-100-AAGN	Right and left version	150	420	Flanged	1/2" SAE 6000	10.02.070
	MLST-150-AAGN	Right and left version	150	420	Flanged	1/2" SAE 6000	10.02.080
	MLST-200-AAGN	Right and left version	250	420	Flanged	3/4" SAE 6000	10.02.090
	MLST-200-AAGN	Right and left version	250	420	Flanged	1" SAE 6000	10.02.100
	MLTT-300-AAGR	Right and left version	350	420	Flanged	3/4" SAE 6000	10.02.110
	MLST-300-AAGN	Right and left version	400	420	Flanged	1" SAE 6000	10.02.120
	MLST-300-AAGN	Right and left version	500	420	Flanged	1 1/4" SAE 6000	10.02.130
	MLST-500-AAJN	Right and left version	500	420	Flanged	3/4" SAE 6000	10.03.140
	MLST-500-AAGN	Right and left version	500	420	Flanged	1" SAE 6000	10.03.150
	MLST-550-AAGN	Right and left version	500	420	Flanged	1 1/4" SAE 6000	10.03.160
	MLST-700-AAGN	Right and left version	700	420	Flanged	1 1/4" SAE 6000	10.03.170
	MLST-700-AAGN	Right and left version	700	420	Flanged	1 1/2" SAE 6000	10.03.180
	MLST-1400-AAGN	Right and left version	1400	420	Flanged	1 1/2" SAE 6000	10.04.190
	MLST-1400-AAGR	Right version	1400	420	Flanged	2" SAE 6000	10.04.200
	MLST-1400-AAGL	Left version	1400	420	Flanged	2" SAE 6000	10.04.210
	MLST-1500-AAGR	Right version	1500	420	Flanged	2" SAE 6000 3" SAE 6000	10.04.220
	MLST-1500-AAGL	Left version	1500	420	Flanged	2" SAE 6000 3" SAE 6000	10.04.230

CHECK AND METERING VALVE

MLST-040-ALGR

IN LINE VERSION
RIGHT VERSION

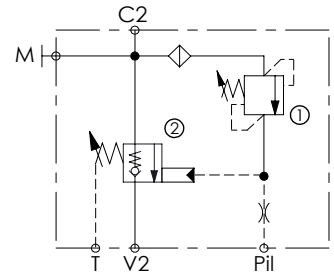
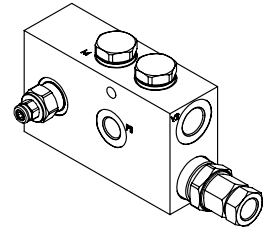
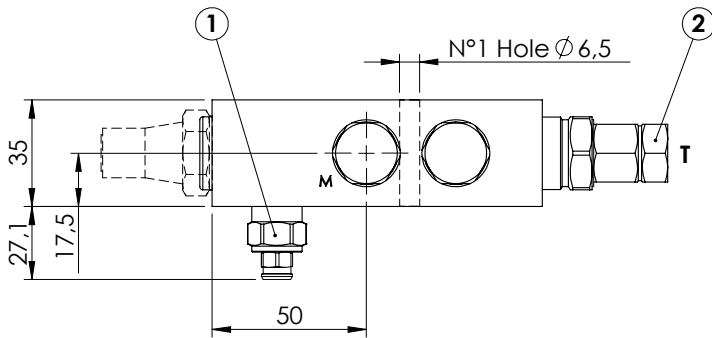
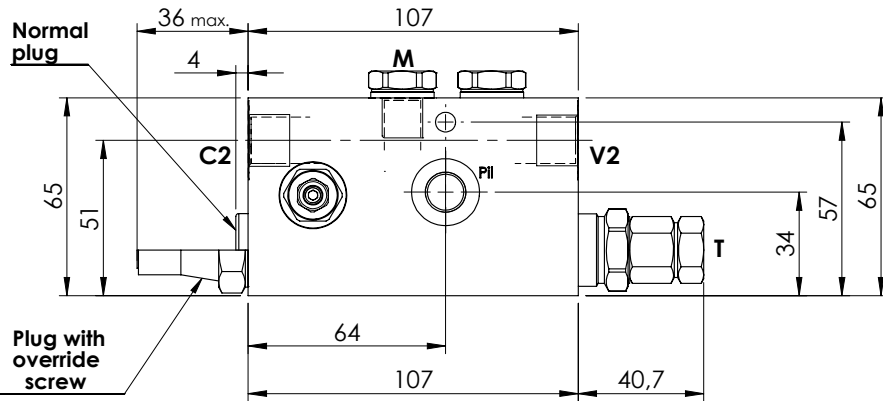

SPECIFICATIONS

Max. operating pressure:	420 bar
Rated flow:	40 l/min
Manifold:	Steel
Weight:	1,86 kg

NOTES

When correctly adjusted for the specific excavator installation, these valves meet the requirement of ISO 8643

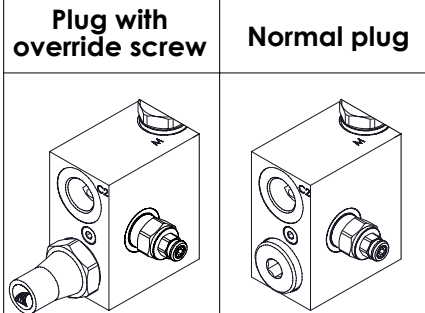
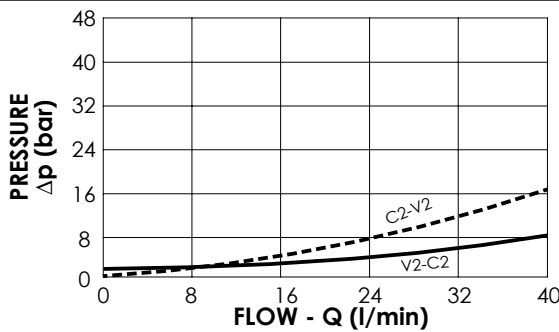

ORDERING CODES

Quick code	Description	Main ports size	Plug with override screw	Standard setting (bar)	Adjust. range (bar)	Pressure increase (bar/turn)
ML000143	MLST-040-ALGR-00-G38-N420	V2,C2: G 3/8" Pil,T,M: G 1/4"	No	① 350 Q=5 l/min ② 7.5 Crack. pr.	① 150-420 ② 3-15	① 236 ② 6.7
ML000144	MLST-040-ALGR-00-G38-E420	V2,C2: G 3/8" Pil,T,M: G 1/4"	Yes	① 350 Q=5 l/min ② 7.5 Crack. pr.	① 150-420 ② 3-15	① 236 ② 6.7
ML000185	MLST-040-ALGR-00-J38-N420	V2,C2: JIS 3/8" Pil,T,M: JIS 1/4"	No	① 350 Q=5 l/min ② 7.5 Crack. pr.	① 150-420 ② 3-15	① 236 ② 6.7
ML000186	MLST-040-ALGR-00-J38-E420	V2,C2: JIS 3/8" Pil,T,M: JIS 1/4"	Yes	① 350 Q=5 l/min ② 7.5 Crack. pr.	① 150-420 ② 3-15	① 236 ② 6.7

CHECK AND METERING VALVE

MLST-040-ALGL

IN LINE VERSION
LEFT VERSION

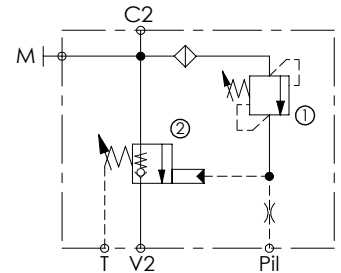
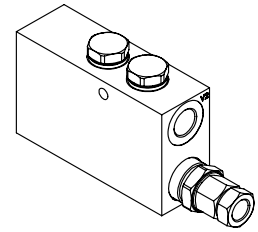
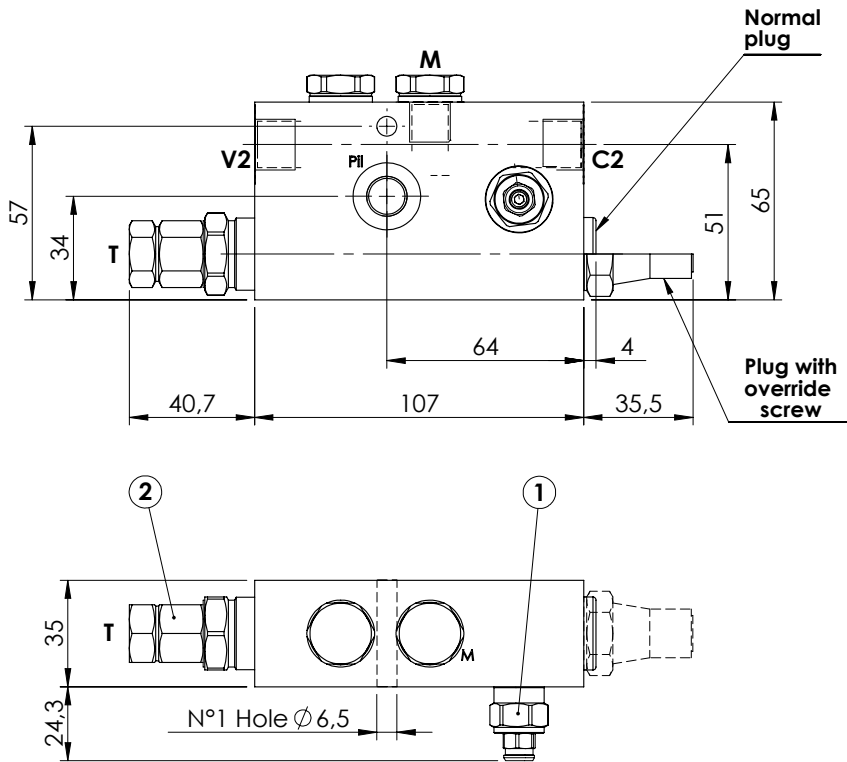

SPECIFICATIONS

Max. operating pressure:	420 bar
Rated flow:	40 l/min
Manifold:	Steel
Weight:	1,86 kg

NOTES

When correctly adjusted for the specific excavator installation, these valves meet the requirement of ISO 8643

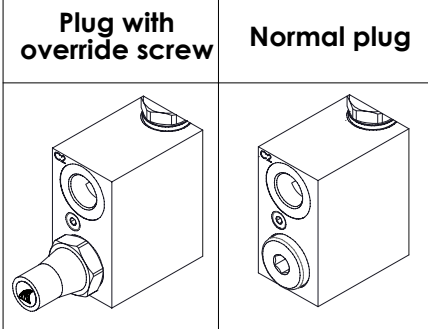
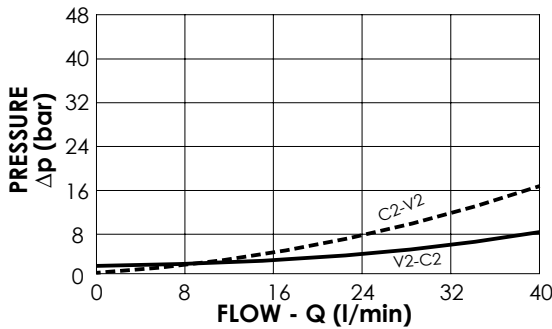

ORDERING CODES

Quick code	Description	Main ports size	Plug with override screw	Standard setting (bar)	Adjust. range (bar)	Pressure increase (bar/turn)
ML000145	MLST-040-ALGL-00-G38-N420	V2,C2: G 3/8" Pil,T,M: G 1/4"	No	① 350 Q=5 l/min ② 7.5 Crack. pr.	① 150-420 ② 3-15	① 236 ② 6.7
ML000146	MLST-040-ALGL-00-G38-E420	V2,C2: G 3/8" Pil,T,M: G 1/4"	Yes	① 350 Q=5 l/min ② 7.5 Crack. pr.	① 150-420 ② 3-15	① 236 ② 6.7
ML000187	MLST-040-ALGL-00-J38-N420	V2,C2: JIS 3/8" Pil,T,M: JIS 1/4"	No	① 350 Q=5 l/min ② 7.5 Crack. pr.	① 150-420 ② 3-15	① 236 ② 6.7
ML000188	MLST-040-ALGL-00-J38-E420	V2,C2: JIS 3/8" Pil,T,M: JIS 1/4"	Yes	① 350 Q=5 l/min ② 7.5 Crack. pr.	① 150-420 ② 3-15	① 236 ② 6.7

CHECK AND METERING VALVE

MLST-100-ALGR

IN LINE VERSION
RIGHT VERSION

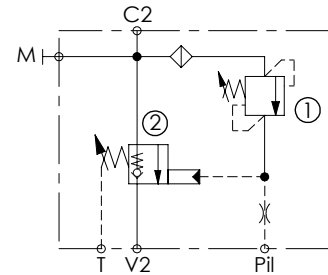
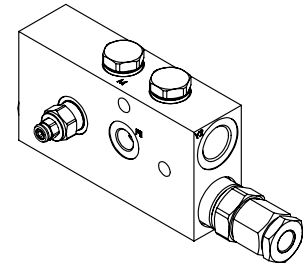
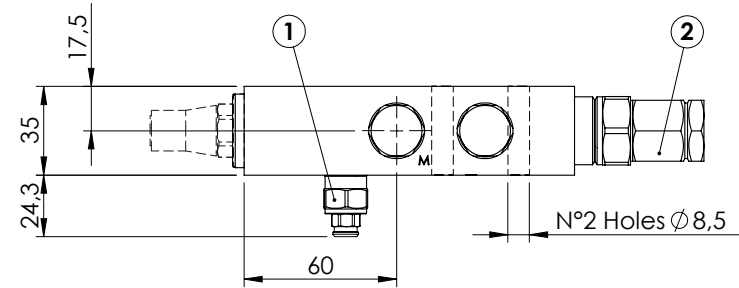
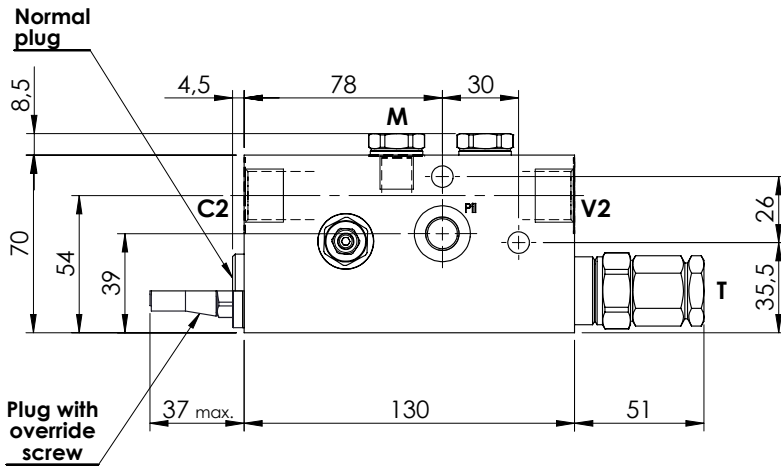

SPECIFICATIONS

Max. operating pressure:	420 bar
Rated flow:	100 l/min
Manifold:	Steel
Weight:	2,39 kg

NOTES

When correctly adjusted for the specific excavator installation, these valves meet the requirement of ISO 8643

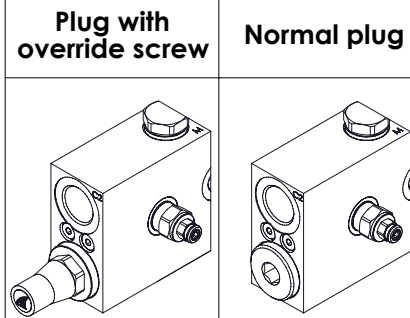
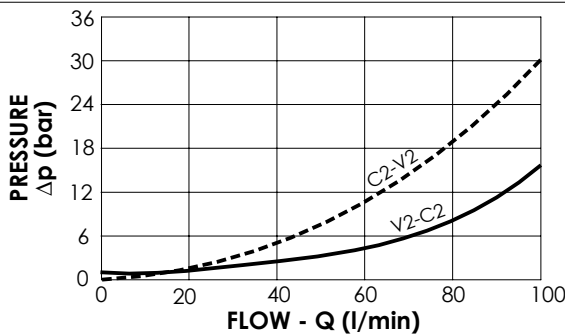

ORDERING CODES

Quick code	Description	Main ports size	Plug with override screw	Standard setting (bar)	Adjust. range (bar)	Pressure increase (bar/turn)
ML000134	MLST-100-ALGR-00-G12-N420	V2,C2: G 1/2" Pii, T, M: G 1/4"	No	① 350 Q=5 l/min ② 7.5 Crack. pr.	① 150-420 ② 3-15	① 236 ② 7
ML000147	MLST-100-ALGR-00-G12-E420	V2,C2: G 1/2" Pii, T, M: G 1/4"	Yes	① 350 Q=5 l/min ② 7.5 Crack. pr.	① 150-420 ② 3-15	① 236 ② 7
ML000135	MLST-100-ALGR-00-J12-N420	V2,C2: JIS 1/2" Pii, T, M: JIS 1/4"	No	① 350 Q=5 l/min ② 7.5 Crack. pr.	① 150-420 ② 3-15	① 236 ② 7
ML000148	MLST-100-ALGR-00-J12-E420	V2,C2: JIS 1/2" Pii, T, M: JIS 1/4"	Yes	① 350 Q=5 l/min ② 7.5 Crack. pr.	① 150-420 ② 3-15	① 236 ② 7

CHECK AND METERING VALVE

MLST-100-ALGL

IN LINE VERSION
LEFT VERSION

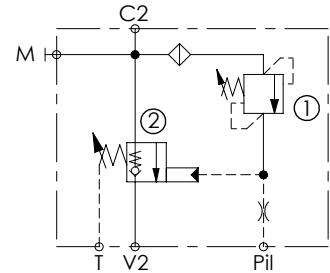
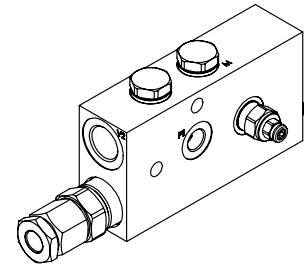
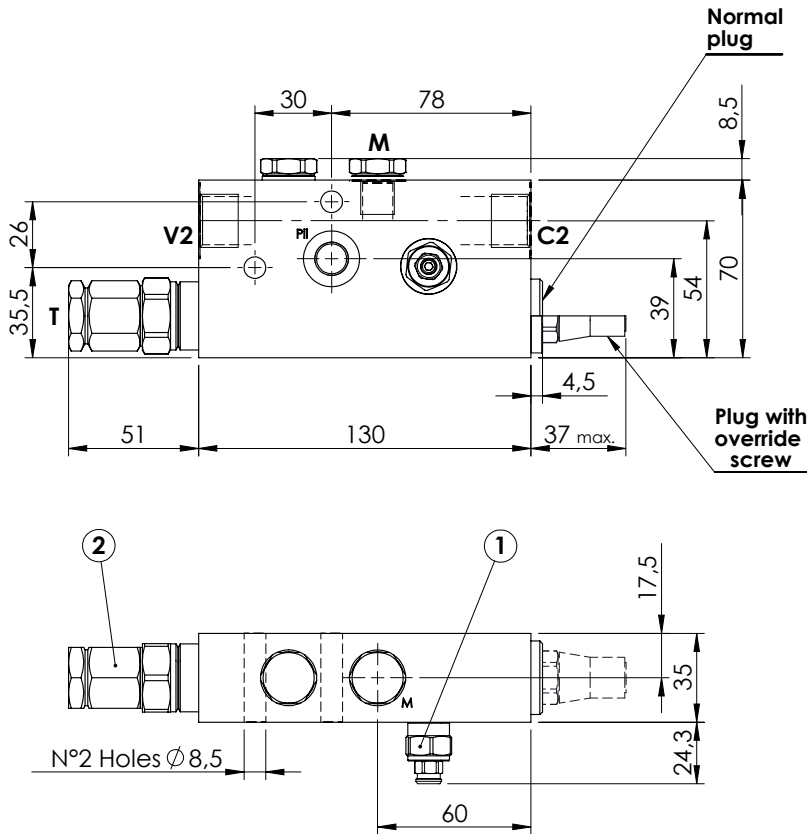

SPECIFICATIONS

Max. operating pressure:	420 bar
Rated flow:	100 l/min
Manifold:	Steel
Weight:	2,39 kg

NOTES

When correctly adjusted for the specific excavator installation, these valves meet the requirement of ISO 8643

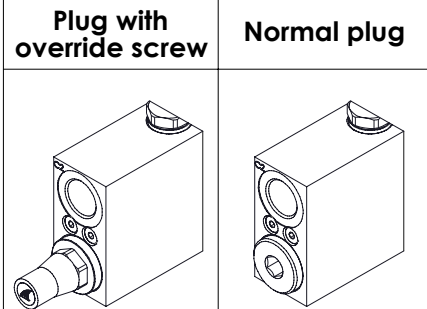
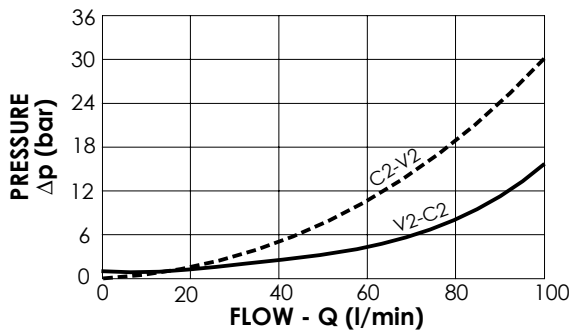

ORDERING CODES

Quick code	Description	Main ports size	Plug with override screw	Standard setting (bar)	Adjust. range (bar)	Pressure increase (bar/turn)
ML000136	MLST-100-ALGL-00-G12-N420	V2,C2: G 1/2" Pi, T, M: G 1/4"	No	① 350 Q=5 l/min ② 7.5 Crack. pr.	① 150-420 ② 3-15	① 236 ② 7
ML000149	MLST-100-ALGL-00-G12-E420	V2,C2: G 1/2" Pi, T, M: G 1/4"	Yes	① 350 Q=5 l/min ② 7.5 Crack. pr.	① 150-420 ② 3-15	① 236 ② 7
ML000137	MLST-100-ALGL-00-J12-N420	V2,C2: JIS 1/2" Pi, T, M: JIS 1/4"	No	① 350 Q=5 l/min ② 7.5 Crack. pr.	① 150-420 ② 3-15	① 236 ② 7
ML000150	MLST-100-ALGL-00-J12-E420	V2,C2: JIS 1/2" Pi, T, M: JIS 1/4"	Yes	① 350 Q=5 l/min ② 7.5 Crack. pr.	① 150-420 ② 3-15	① 236 ② 7

CHECK AND METERING VALVE

MLST-150-ALGR

IN LINE VERSION
RIGHT VERSION

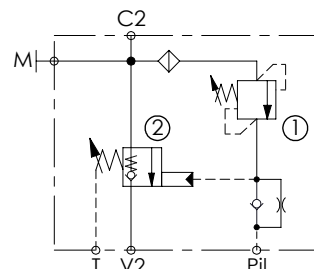
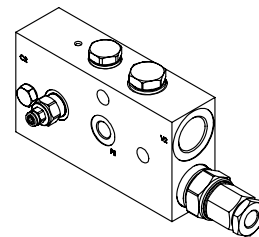
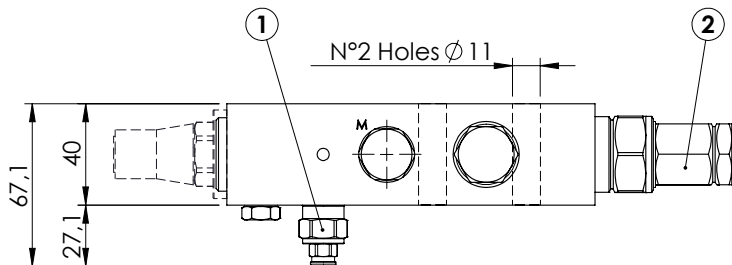
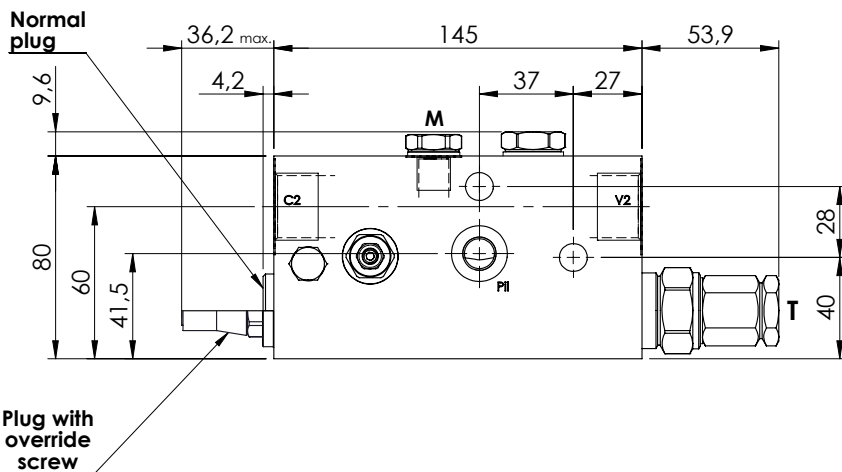

SPECIFICATIONS

Max. operating pressure:	420 bar
Rated flow:	150 l/min
Manifold:	Steel
Weight:	3,35 kg

NOTES

When correctly adjusted for the specific excavator installation, these valves meet the requirement of ISO 8643

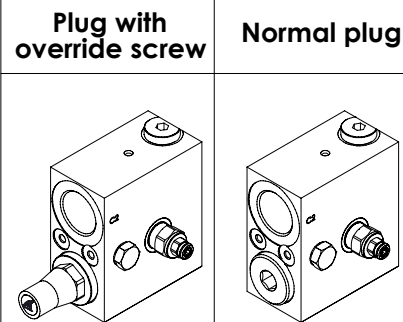
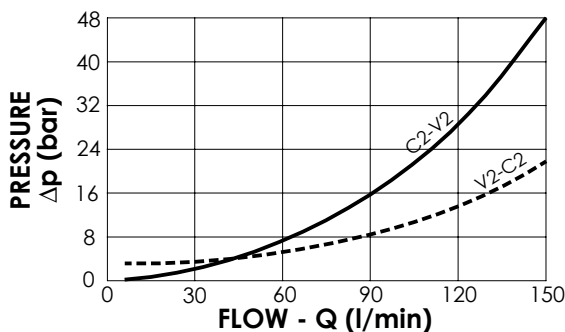

ORDERING CODES

Quick code	Description	Main ports size	Plug with override screw	Standard setting (bar)	Adjust. range (bar)	Pressure increase (bar/turn)
ML000126	MLST-150-ALGR-00-G34-N420	V2,C2: G 3/4" Pil,T,M: G 1/4"	No	① 350 Q=5 l/min ② 7.5 Crack. pr.	① 150-420 ② 3-15	① 236 ② 8
ML000011	MLST-150-ALGR-00-G34-E420	V2,C2: G 3/4" Pil,T,M: G 1/4"	Yes	① 350 Q=5 l/min ② 7.5 Crack. pr.	① 150-420 ② 3-15	① 236 ② 8
ML000122	MLST-150-ALGR-00-U11-N420	V2,C2: 1 1/16-12 UNF Pil,T: 9/16-18 UNF M: G 1/4"	No	① 350 Q=5 l/min ② 7.5 Crack. pr.	① 150-420 ② 3-15	① 236 ② 8
ML000029	MLST-150-ALGR-00-U11-E420	V2,C2: 1 1/16-12 UNF Pil,T: 9/16-18 UNF M: G 1/4"	Yes	① 350 Q=5 l/min ② 7.5 Crack. pr.	① 150-420 ② 3-15	① 236 ② 8
ML000123	MLST-150-ALGR-00-J34-N420	V2,C2: 3/4" JIS Pil,T,M: 1/4" JIS	No	① 350 Q=5 l/min ② 7.5 Crack. pr.	① 150-420 ② 3-15	① 236 ② 8
ML000105	MLST-150-ALGR-00-J34-E420	V2,C2: 3/4" JIS Pil,T,M: 1/4" JIS	Yes	① 350 Q=5 l/min ② 7.5 Crack. pr.	① 150-420 ② 3-15	① 236 ② 8

CHECK AND METERING VALVE

MLST-150-ALGL

IN LINE VERSION
LEFT VERSION

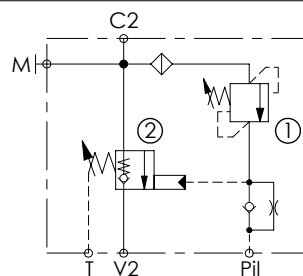
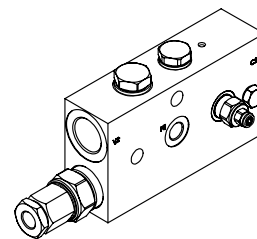
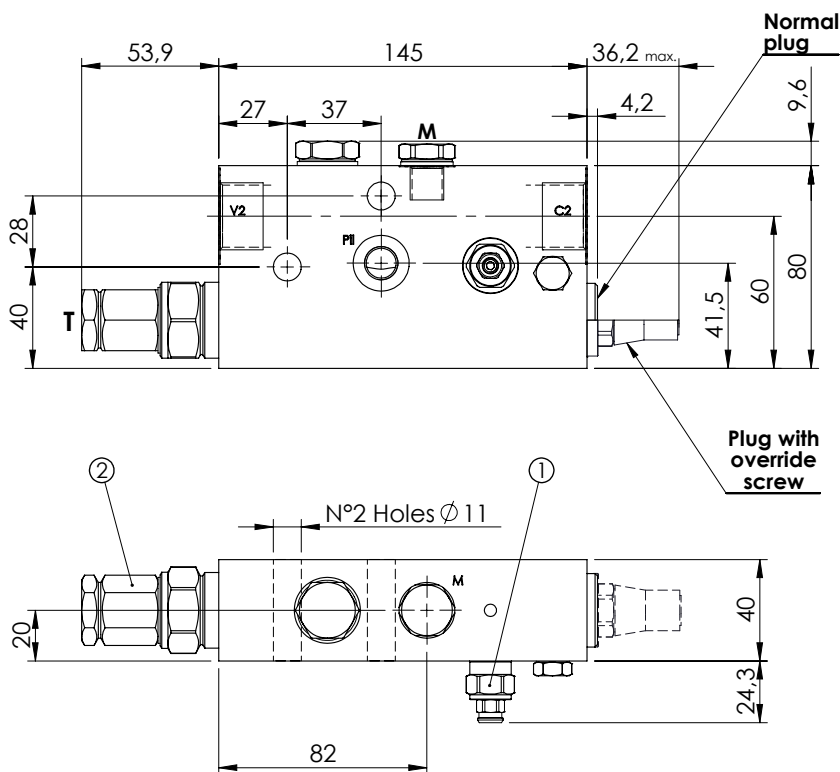

SPECIFICATIONS

Max. operating pressure:	420 bar
Rated flow:	150 l/min
Manifold:	Steel
Weight:	3,35 kg

NOTES

When correctly adjusted for the specific excavator installation, these valves meet the requirement of ISO 8643

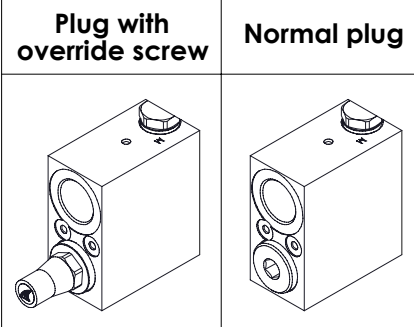
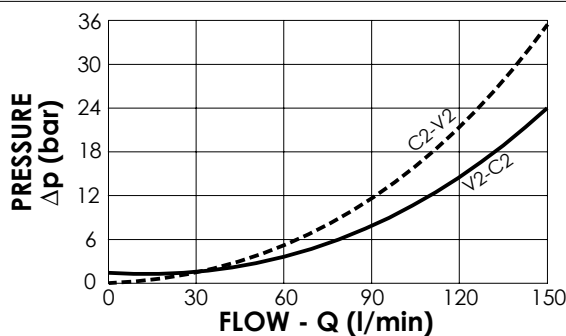

ORDERING CODES

Quick code	Description	Main ports size	Plug with override screw	Standard setting (bar)	Adjust. range (bar)	Pressure increase (bar/turn)
ML000121	MLST-150-ALGL-00-G34-N420	V2,C2: G 3/4" P11,T,M: G 1/4"	No	① 350 Q=5 l/min ② 7.5 Crack. pr.	① 150-420 ② 3-15	① 236 ② 8
ML000010	MLST-150-ALGL-00-G34-E420	V2,C2: G 3/4" P11,T,M: G 1/4"	Yes	① 350 Q=5 l/min ② 7.5 Crack. pr.	① 150-420 ② 3-15	① 236 ② 8
ML000124	MLST-150-ALGL-00-U11-N420	V2,C2: 1 1/16-12 UNF P11,T: 9/16-18 UNF M: G 1/4"	No	① 350 Q=5 l/min ② 7.5 Crack. pr.	① 150-420 ② 3-15	① 236 ② 8
ML000030	MLST-150-ALGL-00-U11-E420	V2,C2: 1 1/16-12 UNF P11,T: 9/16-18 UNF M: G 1/4"	Yes	① 350 Q=5 l/min ② 7.5 Crack. pr.	① 150-420 ② 3-15	① 236 ② 8
ML000125	MLST-150-ALGL-00-J34-N420	V2,C2: 3/4" JIS P11,T,M: 1/4" JIS	No	① 350 Q=5 l/min ② 7.5 Crack. pr.	① 150-420 ② 3-15	① 236 ② 8
ML000104	MLST-150-ALGL-00-J34-E420	V2,C2: 3/4" JIS P11,T,M: 1/4" JIS	Yes	① 350 Q=5 l/min ② 7.5 Crack. pr.	① 150-420 ② 3-15	① 236 ② 8

CHECK AND METERING VALVE

MLST-100-AAGN

FLANGED TYPE
1/2" SAE 6000

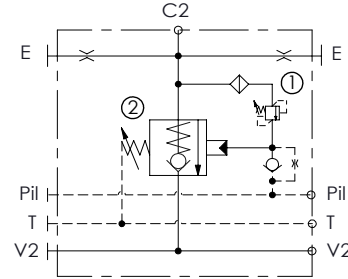
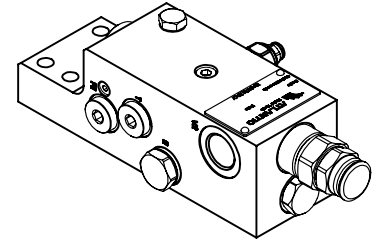
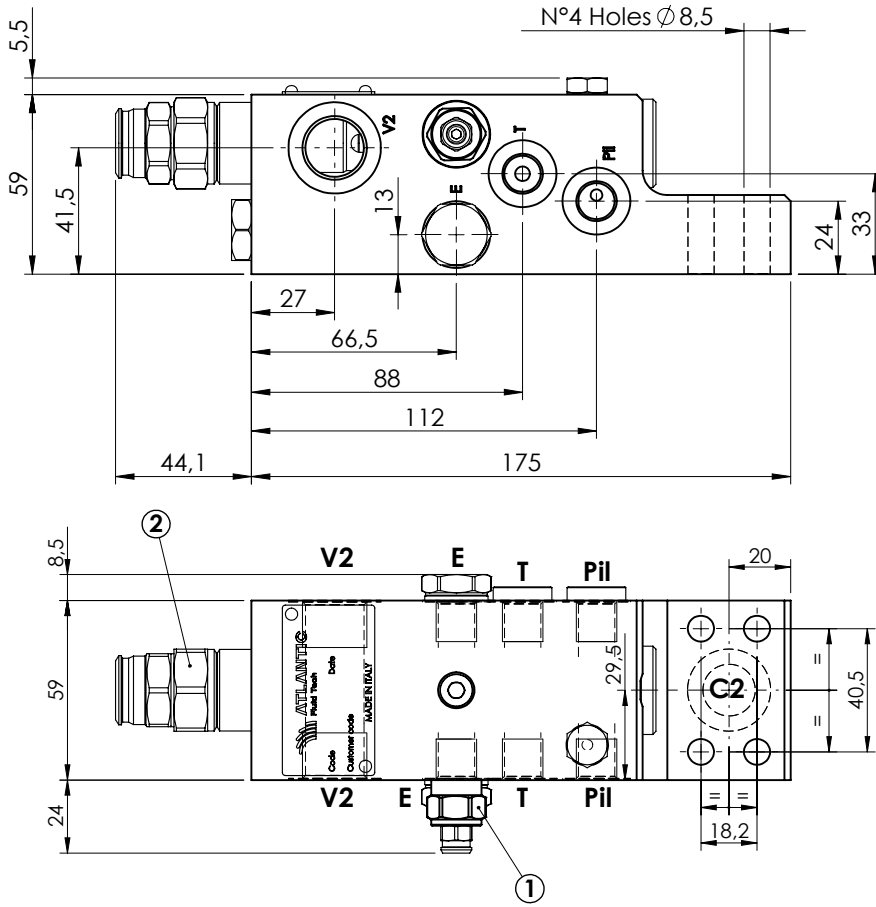

SPECIFICATIONS

Max. operating pressure:	420 bar
Rated flow:	100 l/min
Manifold:	Steel
Weight:	3,87 kg

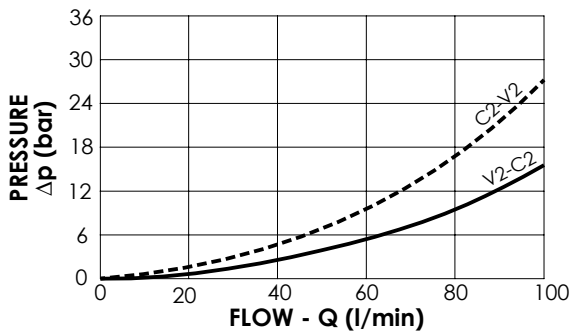

NOTES

When correctly adjusted for the specific excavator installation, these valves meet the requirement of ISO 8643

ORDERING CODES

Quick code	Description	Main ports size	Standard setting (bar)	Adjust. range (bar)	Pressure increase (bar/turn)
ML000130	MLST-100-AAGN-00-S12-N420	C2: 1/2" SAE 6000 V2: G 1/2" E, Pil, T: G 1/4	① 350 Q=5 l/min ② 7.5 Crack. pr.	① 150-420 ② 3-15	① 236 ② 6

CHECK AND METERING VALVE

MLST-150-AAGN

**FLANGED TYPE
1/2" SAE 6000**

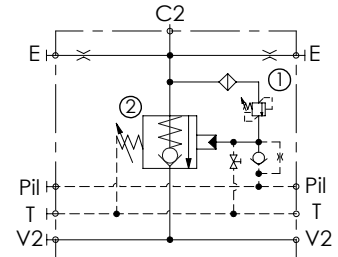
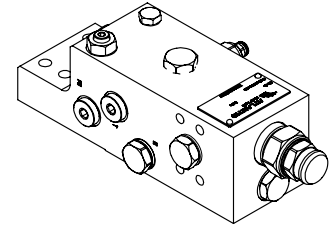
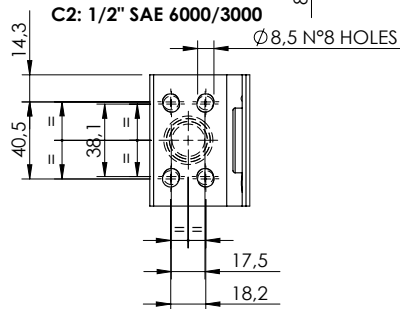
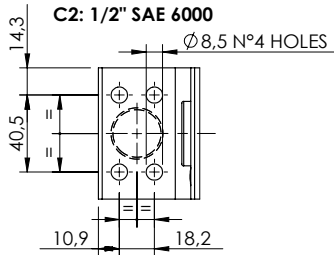
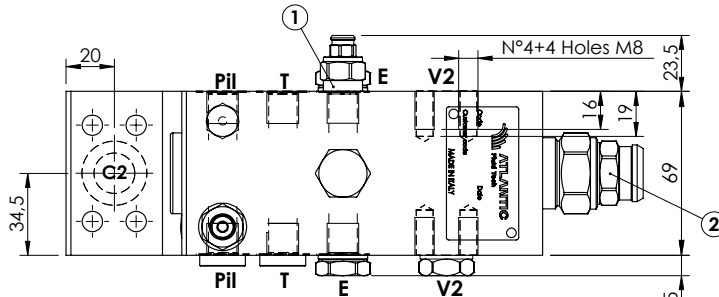
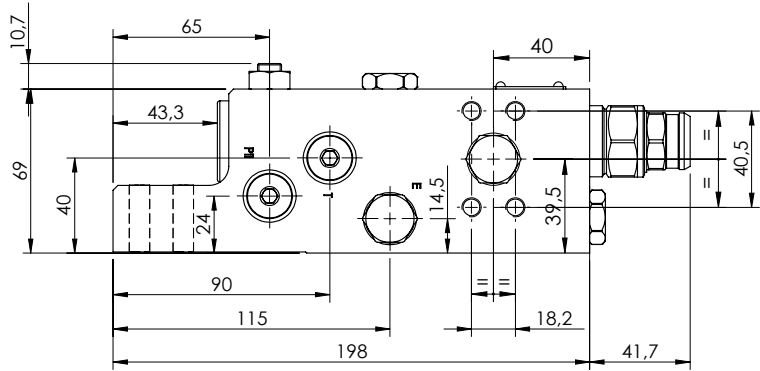

SPECIFICATIONS

Max. operating pressure:	420 bar
Rated flow:	150 l/min
Manifold:	Steel
Weight:	6,09 kg

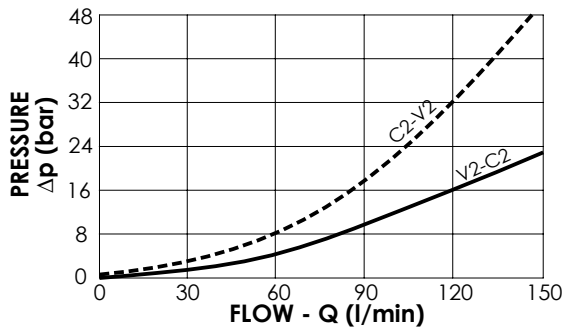

NOTES

When correctly adjusted for the specific excavator installation, these valves meet the requirement of ISO 8643

ORDERING CODES

Quick code	Description	Main ports size	Standard setting (bar)	Adjust. range (bar)	Pressure increase (bar/turn)
ML000082	MLST-150-AAGN-00-S12-N420	V2,C2: 1/2" SAE 6000 E,P11,T: G 1/4"	① 350 Q=5 l/min ② 7.5 Crack. pr.	① 150-420 ② 3-15	① 236 ② 5
ML000083	MLST-150-ASGN-00-S12-N420	C2: 1/2" SAE 6000/3000 V2: 1/2" SAE 6000 E,P11,T: G 1/4"	① 350 Q=5 l/min ② 7.5 Crack. pr.	① 150-420 ② 3-15	① 236 ② 5

CHECK AND METERING VALVE

MLST-200-AAGN

**FLANGED TYPE
3/4" SAE 6000**

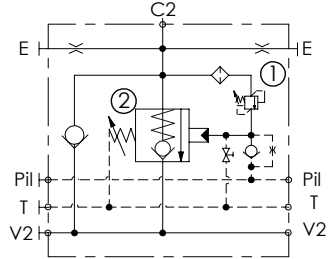
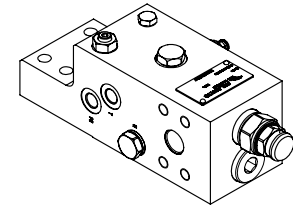
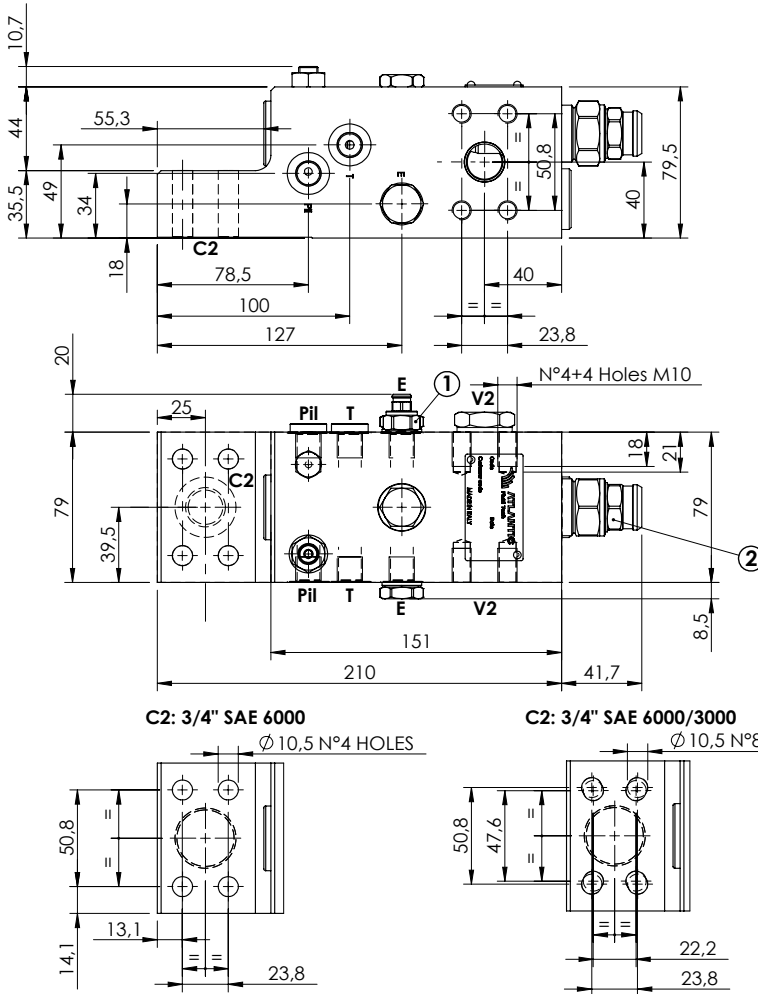

SPECIFICATIONS

Max. operating pressure:	420 bar
Rated flow:	250 l/min
Manifold:	Steel
Weight:	8,15 kg

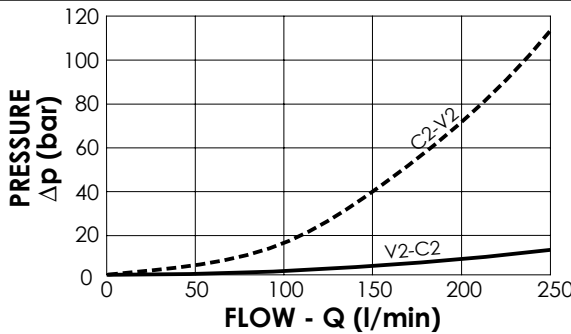

NOTES

When correctly adjusted for the specific excavator installation, these valves meet the requirement of ISO 8643

ORDERING CODES

Quick code	Description	Main ports size	Standard setting (bar)	Adjust. range (bar)	Pressure increase (bar/turn)
ML000075	MLST-200-AAGN-00-S34-N420	V2,C2: 3/4" SAE 6000 E,Pil,T: G 1/4"	① 350 Q=5 l/min ② 7.5 Crack. pr.	① 150-420 ② 3-15	① 236 ② 5
ML000076	MLST-200-AAUD-00-S34-N420	V2,C2: 3/4" SAE 6000 E,Pil,T: 9/16-18 UNF-2B	① 350 Q=5 l/min ② 7.5 Crack. pr.	① 150-420 ② 3-15	① 236 ② 5
ML000091	MLST-200-ASGN-00-S34-N420	V2: 3/4" SAE 6000 C2: 3/4" SAE 6000/3000 E,Pil,T: G 1/4"	① 350 Q=5 l/min ② 7.5 Crack. pr.	① 150-420 ② 3-15	① 236 ② 5
ML000112	MLST-200-ASJN-00-S34-N420	V2,C2: 3/4" SAE 6000 E,Pil,T: 1/4" JIS	① 350 Q=5 l/min ② 7.5 Crack. pr.	① 150-420 ② 3-15	① 236 ② 5

CHECK AND METERING VALVE

MLST-200-AAGN

FLANGED TYPE
1" SAE 6000

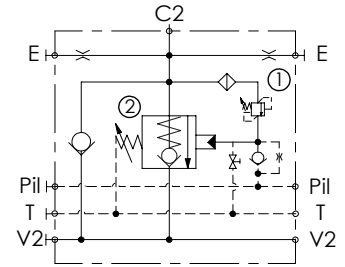
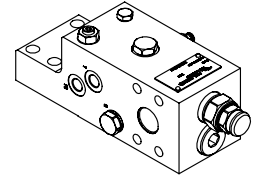
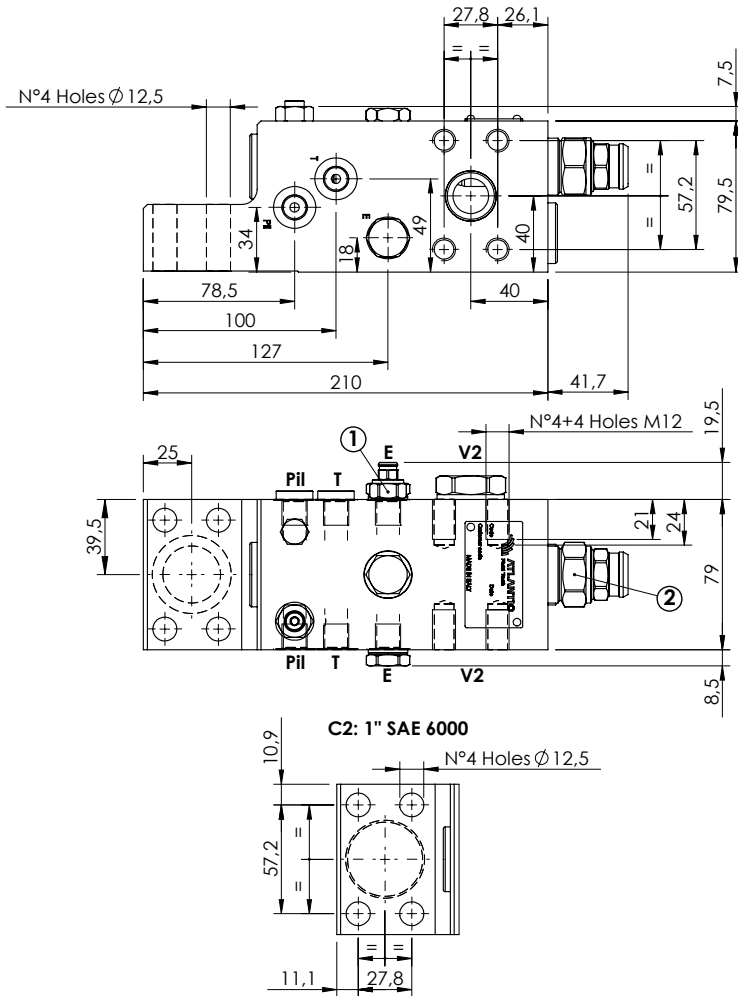

SPECIFICATIONS

Max. operating pressure:	420 bar
Rated flow:	250 l/min
Manifold:	Steel
Weight:	8 kg

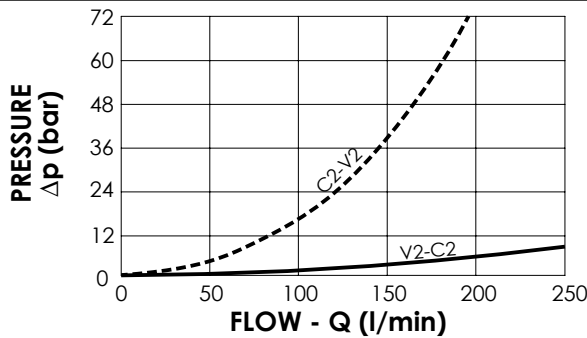

NOTES

When correctly adjusted for the specific excavator installation, these valves meet the requirement of ISO 8643

ORDERING CODES

Quick code	Description	Main ports size	Standard setting (bar)	Adjust. range (bar)	Pressure increase (bar/turn)
ML000138	MLST-200-AAGN-00-S10-N420	V2,C2: 1" SAE 6000 E,P11,T: G 1/4"	① 350 Q=5 l/min ② 7.5 Crack. pr.	① 150-420 ② 3-15	① 236 ② 5

CHECK AND METERING VALVE

MLST-300-AAGR

**FLANGED TYPE
3/4" SAE 6000**

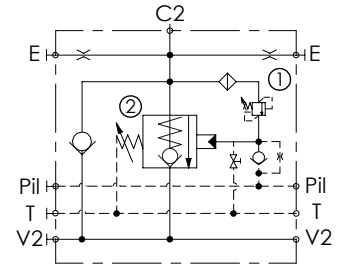
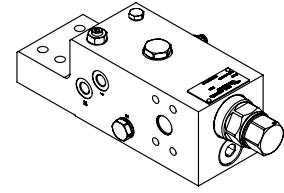
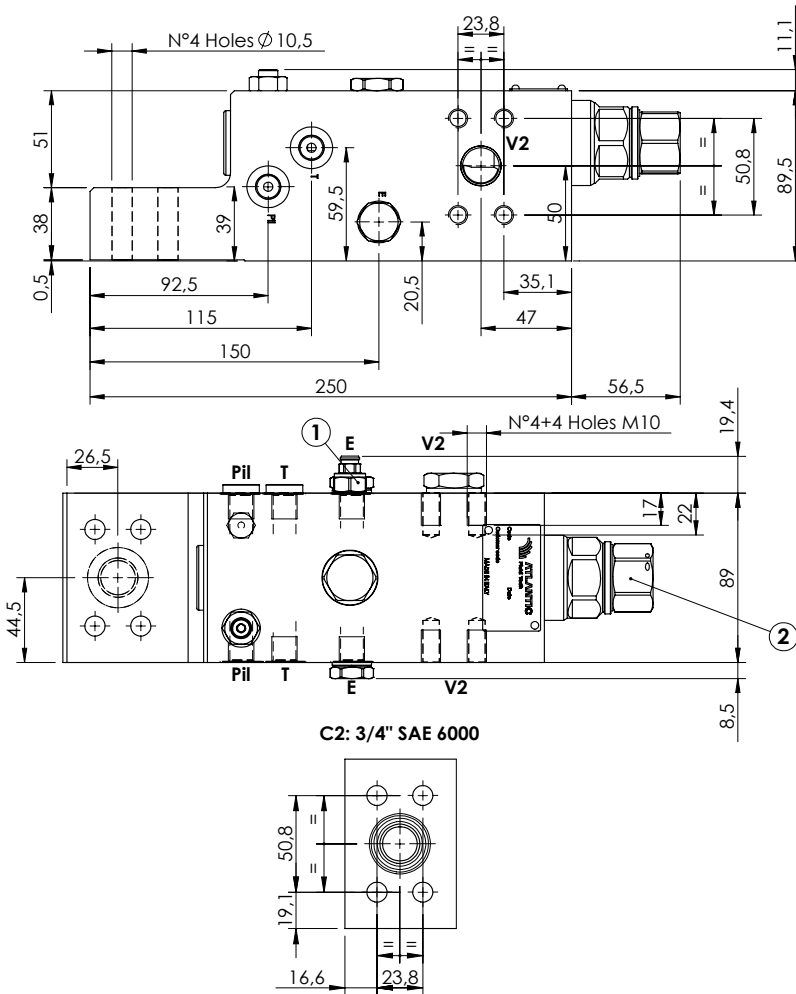

SPECIFICATIONS

Max. operating pressure:	420 bar
Rated flow:	350 l/min
Manifold:	Steel
Weight:	12,27 kg

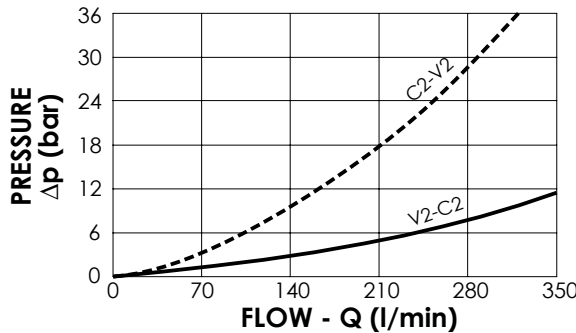

NOTES

When correctly adjusted for the specific excavator installation, these valves meet the requirement of ISO 8643

ORDERING CODES

Quick code	Description	Main ports size	Standard setting (bar)	Adjust. range (bar)	Pressure increase (bar/turn)
ML000106	MLST-300-AAGR-00-S34-N420	V2,C2: 3/4" SAE 6000 E,P11,T: G 1/4"	① 350 Q=5 l/min ② 7.5 Crack. pr.	① 150-420 ② 3-15	① 236 ② 3.4
ML000115	MLST-300-AAJR-00-S34-N420	V2,C2: 3/4" SAE 6000 E,P11,T: 1/4" JIS	① 350 Q=5 l/min ② 7.5 Crack. pr.	① 150-420 ② 3-15	① 236 ② 3.4

CHECK AND METERING VALVE

MLST-300-AAGN

FLANGED TYPE
1" SAE 6000

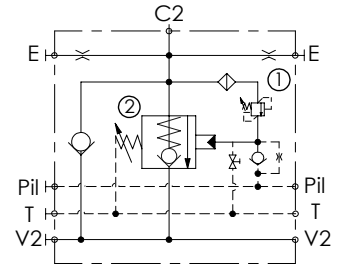
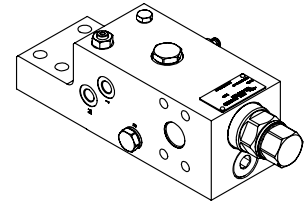
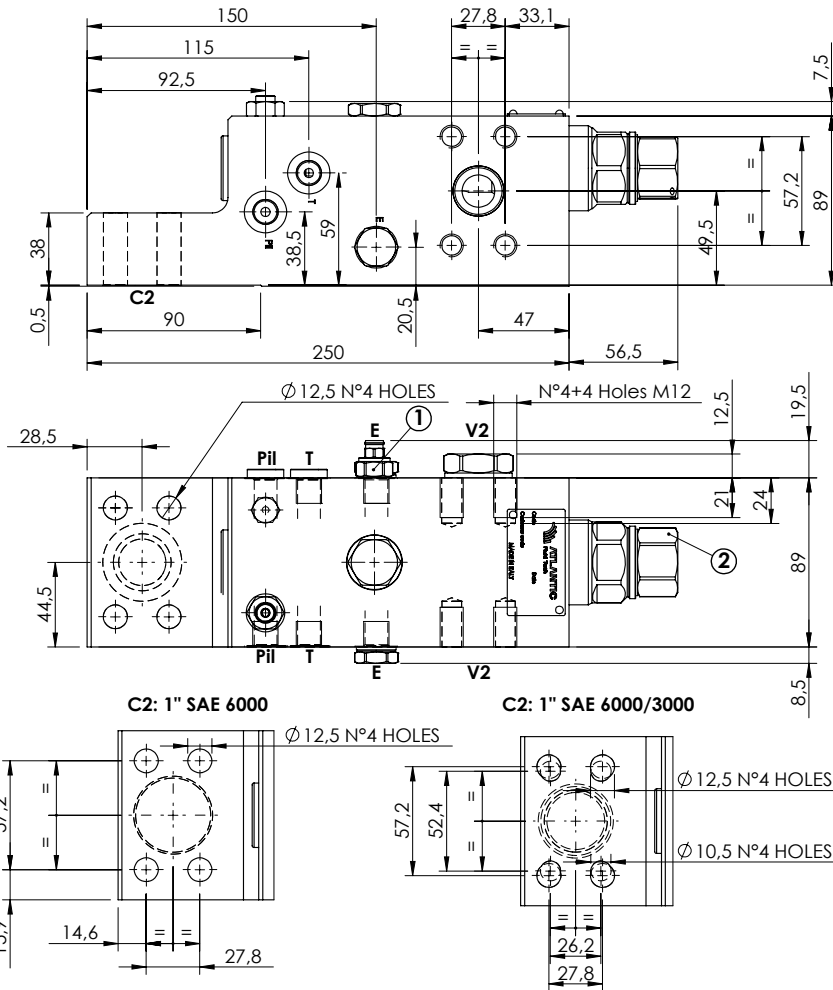

SPECIFICATIONS

Max. operating pressure:	420 bar
Rated flow:	400 l/min
Manifold:	Steel
Weight:	12,14 kg

NOTES

When correctly adjusted for the specific excavator installation, these valves meet the requirement of ISO 8643

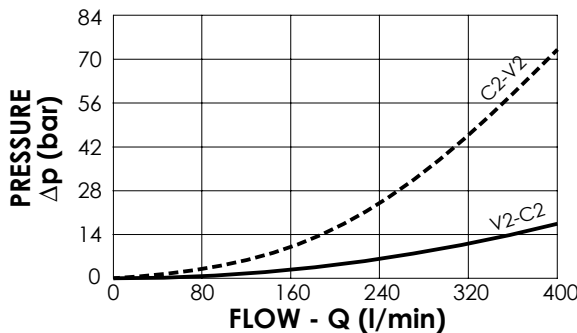

ORDERING CODES

Quick code	Description	Main ports size	Standard setting (bar)	Adjust. range (bar)	Pressure increase (bar/turn)
ML000079	MLST-300-AAGN-00-S10-N420	V2,C2: 1" SAE 6000 E,Pil,T: G 1/4"	① 350 Q=5 l/min ② 7.5 Crack. pr.	① 150-420 ② 3-15	① 236 ② 3.4
ML000080	MLST-300-AAUN-00-S10-N420	V2,C2: 1" SAE 6000 E,Pil,T: 9/16-18 UNF-2B	① 350 Q=5 l/min ② 7.5 Crack. pr.	① 150-420 ② 3-15	① 236 ② 3.4
ML000081	MLST-300-ASGN-00-S10-N420	V2: 1" SAE 6000 C2: 1" SAE 6000/3000 E, Pil, T: G 1/4"	① 350 Q=5 l/min ② 7.5 Crack. pr.	① 150-420 ② 3-15	① 236 ② 3.4
ML000177	MLST-300-ASJN-00-S10-N420	V2,C2: 1" SAE 6000 E, Pil, T: JIS 1/4"	① 350 Q=5 l/min ② 7.5 Crack. pr.	① 150-420 ② 3-15	① 236 ② 3.4

CHECK AND METERING VALVE

MLST-300-AAGN

FLANGED TYPE
1 1/4" SAE 6000

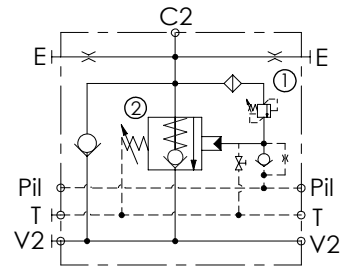
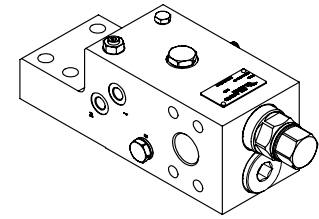
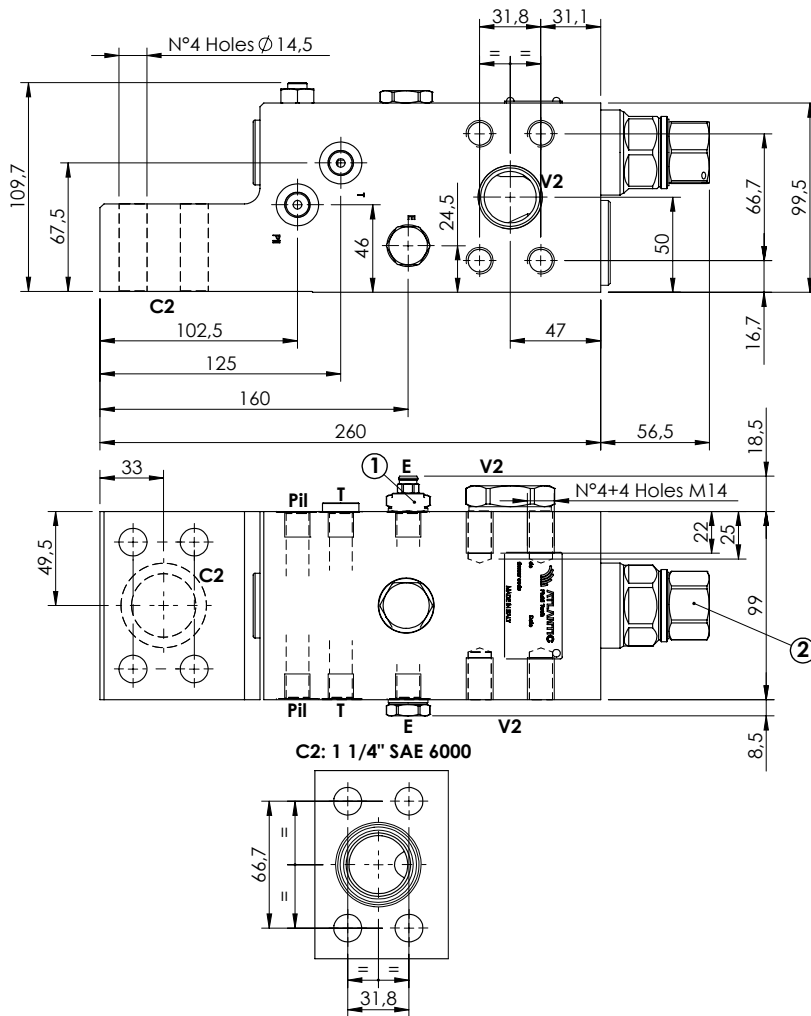

SPECIFICATIONS

Max. operating pressure:	420 bar
Rated flow:	500 l/min
Manifold:	Steel
Weight:	15,17 kg

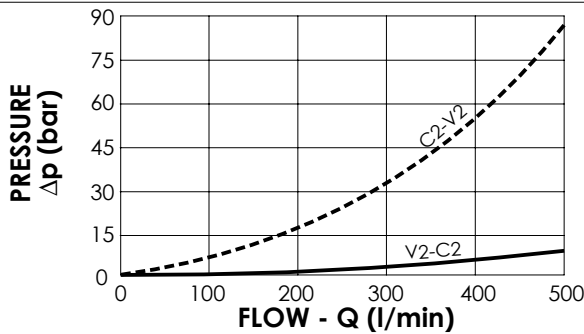

NOTES

When correctly adjusted for the specific excavator installation, these valves meet the requirement of ISO 8643

ORDERING CODES

Quick code	Description	Main ports size	Standard setting (bar)	Adjust. range (bar)	Pressure increase (bar/turn)
ML000077	MLST-300-AAGN-00-S11-N420	V2,C2: 1 1/4" SAE 6000 E,Pil,T: G 1/4"	① 350 Q=5 l/min ② 7.5 Crack. pr.	① 150-420 ② 3-15	① 236 ② 3.4
ML000078	MLST-300-AAUN-00-S11-N420	V2,C2: 1 1/4" SAE 6000 E,Pil,T: 9/16-18 UNF-2B	① 350 Q=5 l/min ② 7.5 Crack. pr.	① 150-420 ② 3-15	① 236 ② 3.4
ML000131	MLST-300-AAJN-00-S11-N420	V2,C2: 1 1/4" SAE 6000 E,Pil,T: 1/4" JIS	① 350 Q=5 l/min ② 7.5 Crack. pr.	① 150-420 ② 3-15	① 236 ② 3.4

CHECK AND METERING VALVE

MLST-500-AAJN

FLANGED TYPE
3/4" SAE 6000

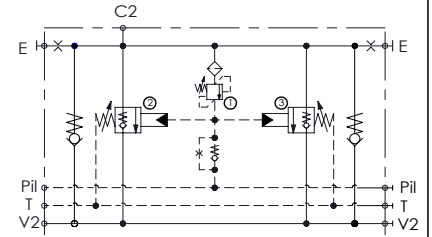
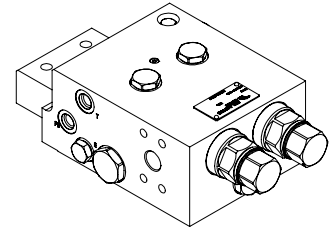
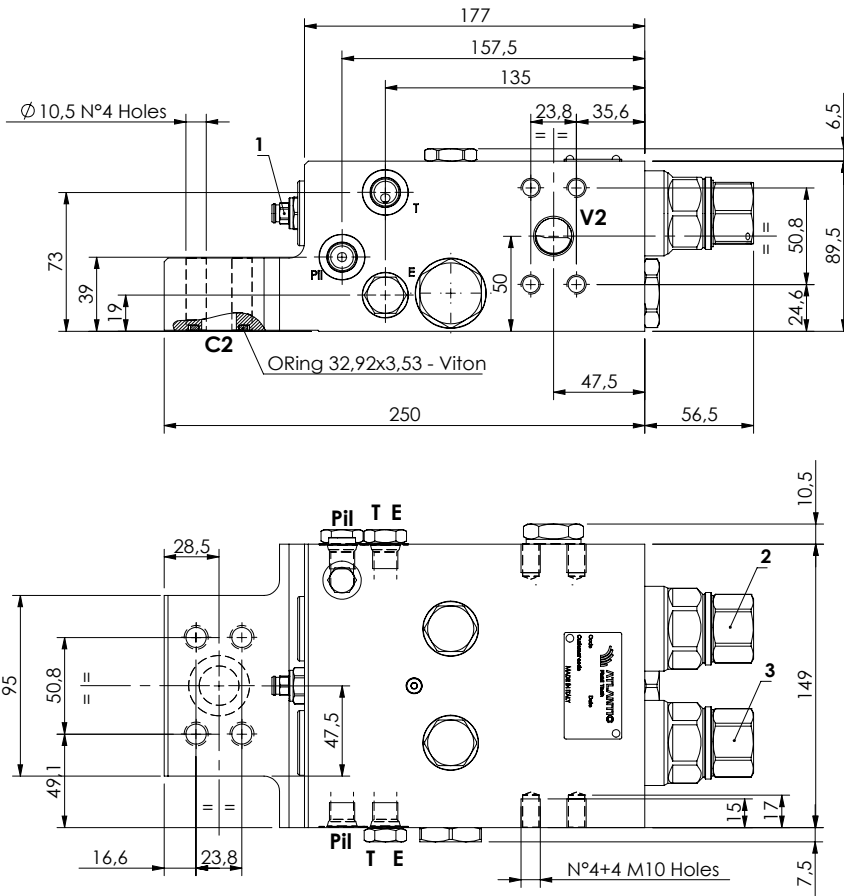

SPECIFICATIONS

Max. operating pressure:	420 bar
Rated flow:	500 l/min
Manifold:	Steel
Weight:	19,57 kg

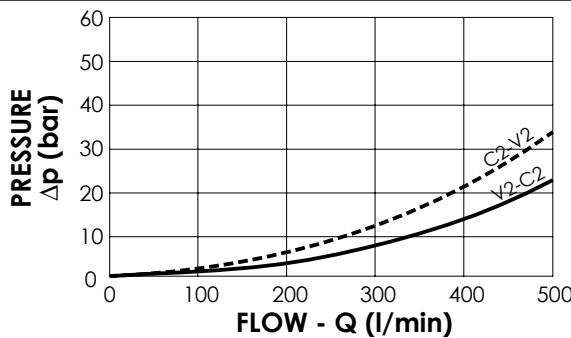

NOTES

When correctly adjusted for the special excavator installation, these valves meet the requirement of ISO 8643

ORDERING CODES

Quick code	Description	Main ports size	Standard setting (bar)	Adjust. range (bar)	Pressure increase (bar/turn)
ML000263	MLST-500-AAJN-00-S34-N420	V2,C2: 3/4" SAE 6000 E,Pii,T: JIS 1/4"	① 350 Q=5 l/min ②③7.5 Crack. pr.	① 150-420 ②③3-15	① 236 ②③3.4

CHECK AND METERING VALVE

MLST-500-AAGN

FLANGED TYPE
1" SAE 6000

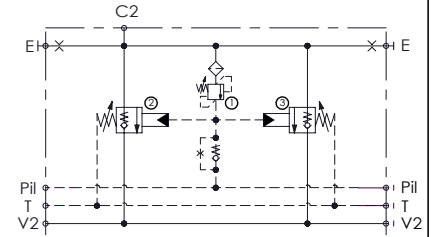
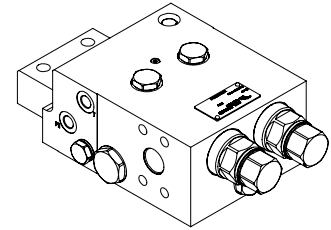
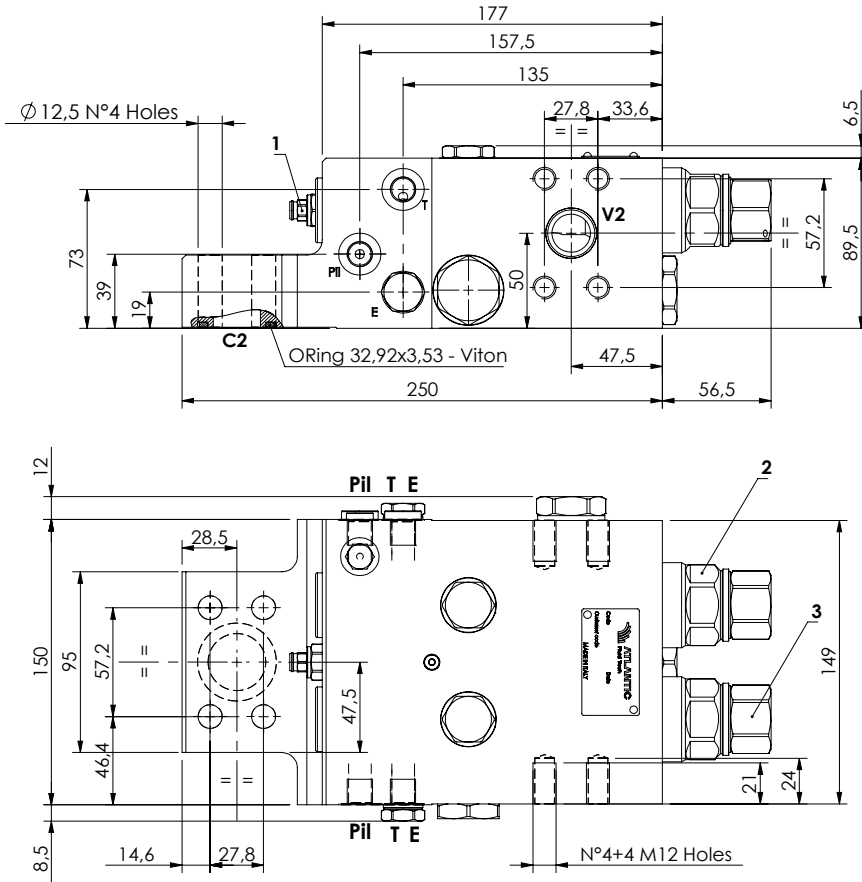

SPECIFICATIONS

Max. operating pressure:	420 bar
Rated flow:	500 l/min
Manifold:	Steel
Weight:	19,49 kg

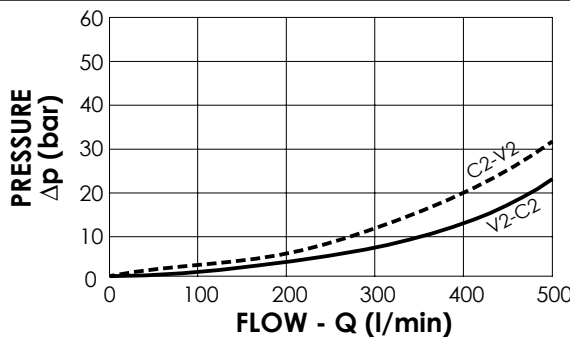

NOTES

When correctly adjusted for the special excavator installation, these valves meet the requirement of ISO 8643

ORDERING CODES

Quick code	Description	Main ports size	Standard setting (bar)	Adjust. range (bar)	Pressure increase (bar/turn)
ML000113	MLST-500-AAGN-00-S10-N420	V2,C2: 1" SAE 6000 E,Pil,T: G 1/4"	① 370 Q=5 l/min ② 10 Crack. pr. ③ 7.5 Crack. pr.	① 150-420 ②③ 3-15	① 236 ②③ 3.4

CHECK AND METERING VALVE

MLST-550-AAGN

FLANGED TYPE
1" 1/4 SAE 6000

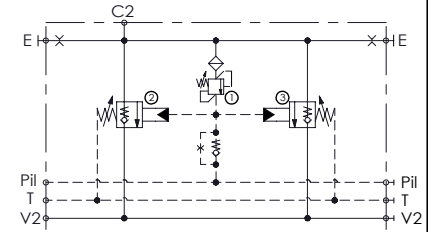
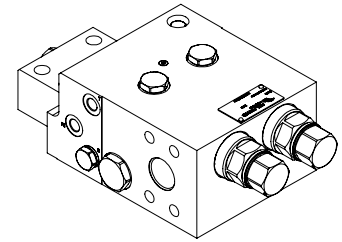
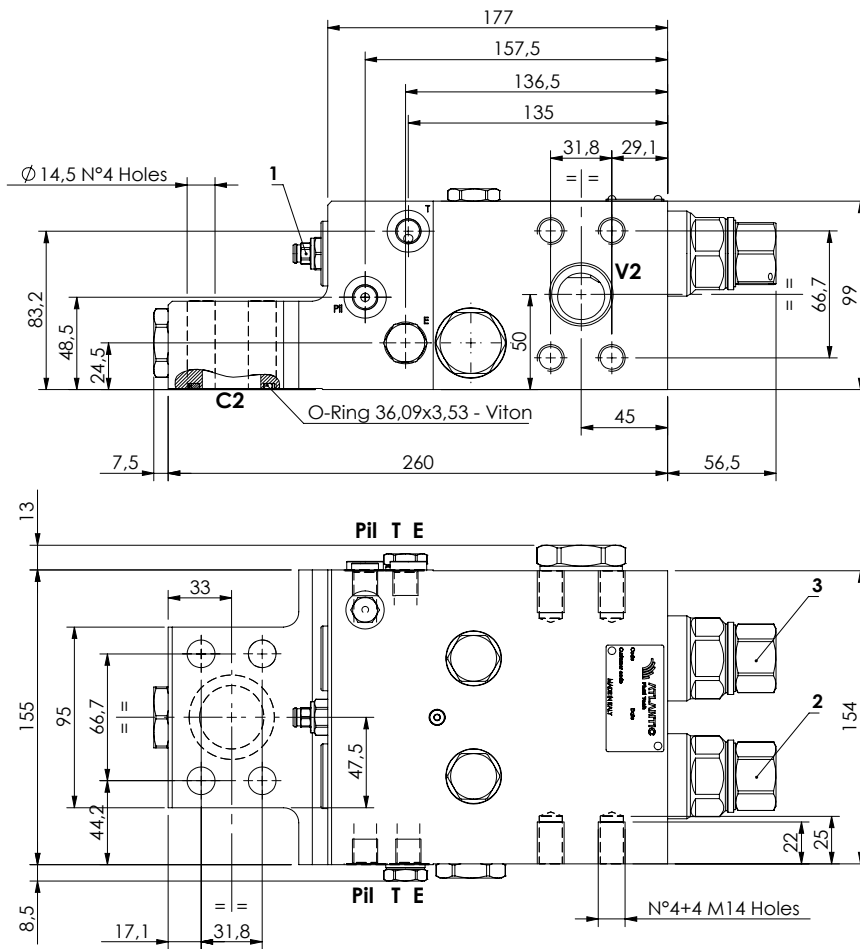

SPECIFICATIONS

Max. operating pressure:	420 bar
Rated flow:	550 l/min
Manifold:	Steel
Weight:	22,67 kg

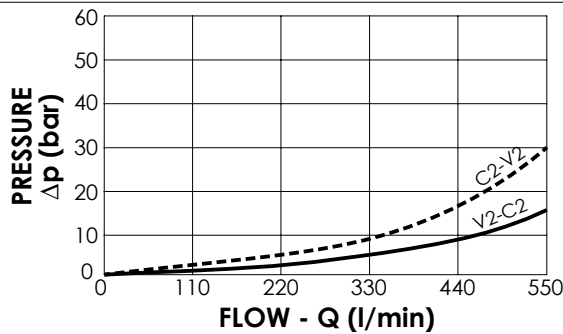

NOTES

When correctly adjusted for the special excavator installation, these valves meet the requirement of ISO 8643

ORDERING CODES

Quick code	Description	Main ports size	Standard setting (bar)	Adjust. range (bar)	Pressure increase (bar/turn)
ML000161	MLST-550-AAGN-00-S11-N420	V2,C2:1" 1/4 SAE 6000 E,Pil,T:G 1/4"	① 350 Q=5 l/min ②③ 7.5 Crack. pr.	① 150-420 ②③ 3-15	① 236 ②③ 3.4

CHECK AND METERING VALVE

MLST-700-AAGN

**FLANGED TYPE
1" 1/4 SAE 6000**

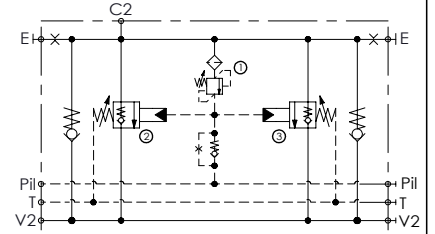
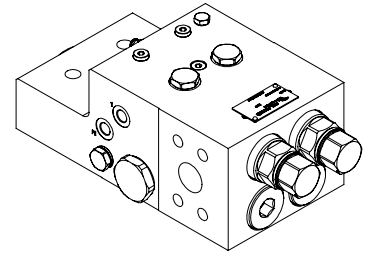
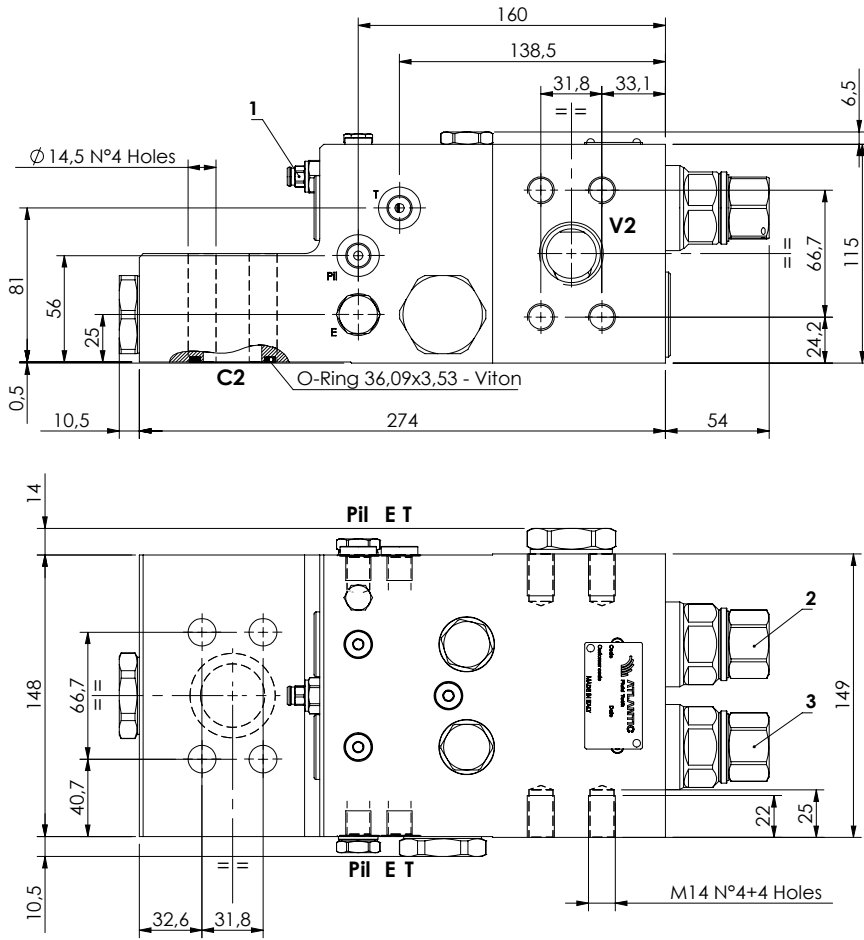

SPECIFICATIONS

Max. operating pressure:	420 bar
Rated flow:	700 l/min
Manifold:	Steel
Weight:	27,5 kg

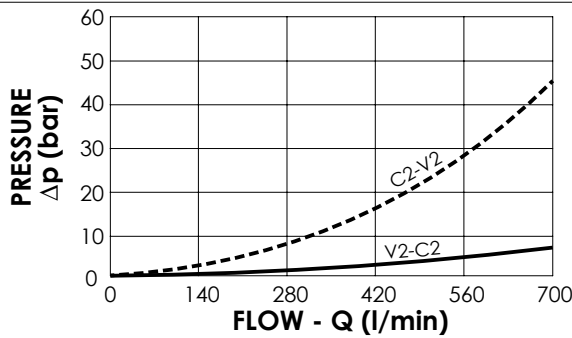

NOTES

When correctly adjusted for the special excavator installation, these valves meet the requirement of ISO 8643

ORDERING CODES

Quick code	Description	Main ports size	Standard setting (bar)	Adjust. range (bar)	Pressure increase (bar/turn)
ML000211	MLST-700-AAGN-00-S11-N420	V2,C2:1" 1/4 SAE 6000 E,P,I,T:G 1/4"	① 400 Q=5 l/min ② 10.5 Crack. pr. ③ 7.5 Crack. pr.	① 150-420 ②③ 3-15	① 236 ②③ 3.4

CHECK AND METERING VALVE

MLST-700-AAGN

FLANGED TYPE
1" 1/2 SAE 6000

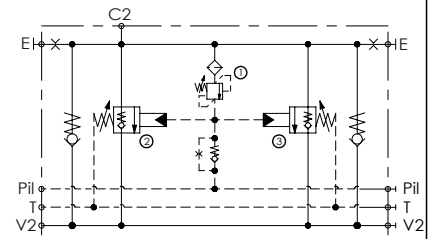
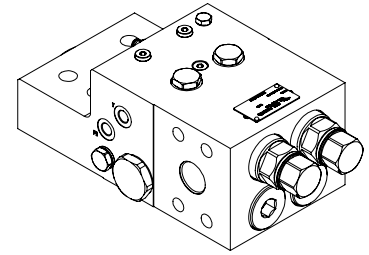
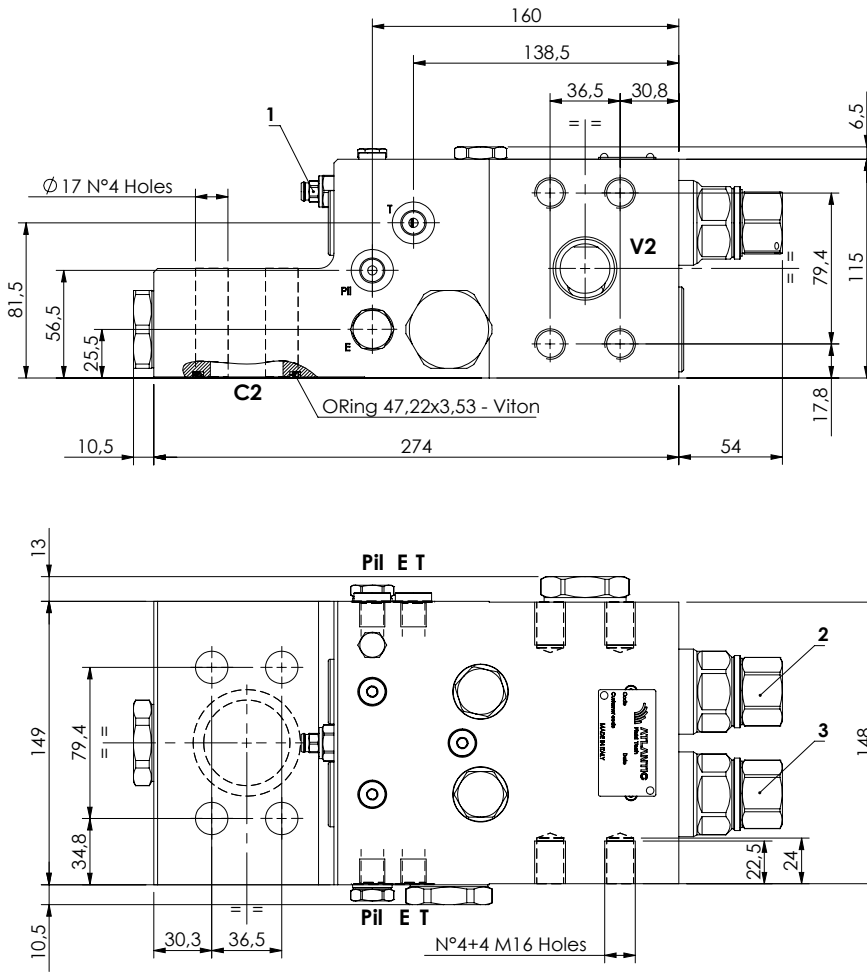

SPECIFICATIONS

Max. operating pressure:	420 bar
Rated flow:	700 l/min
Manifold:	Steel
Weight:	27,3 kg

NOTES

When correctly adjusted for the special excavator installation, these valves meet the requirement of ISO 8643

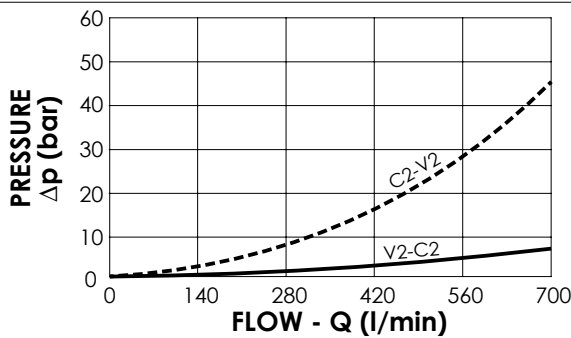

ORDERING CODES

Quick code	Description	Main ports size	Standard setting (bar)	Adjust. range (bar)	Pressure increase (bar/turn)
ML000098	MLST-700-AAGN-00-S22-N420	V2,C2:1" 1/2 SAE 6000 E,Pil,T:G 1/4"	① 400 Q=5 l/min ② 10.5 Crack. pr. ③ 7.5 Crack. pr.	① 150-420 ②③ 3-15	① 236 ②③ 3.4
ML000094	MLST-700-AAJN-00-S22-N420	V2,C2:1" 1/2 SAE 6000 E,Pil,T:1/4" JIS	① 400 Q=5 l/min ② 10.5 Crack. pr. ③ 7.5 Crack. pr.	① 150-420 ②③ 3-15	① 236 ②③ 3.4

CHECK AND METERING VALVE

MLST-1400-AAGN FLANGED TYPE
1" 1/2 SAE 6000

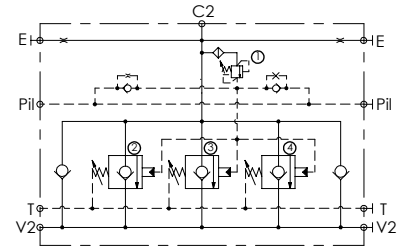
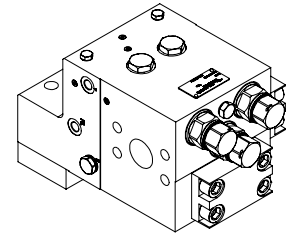
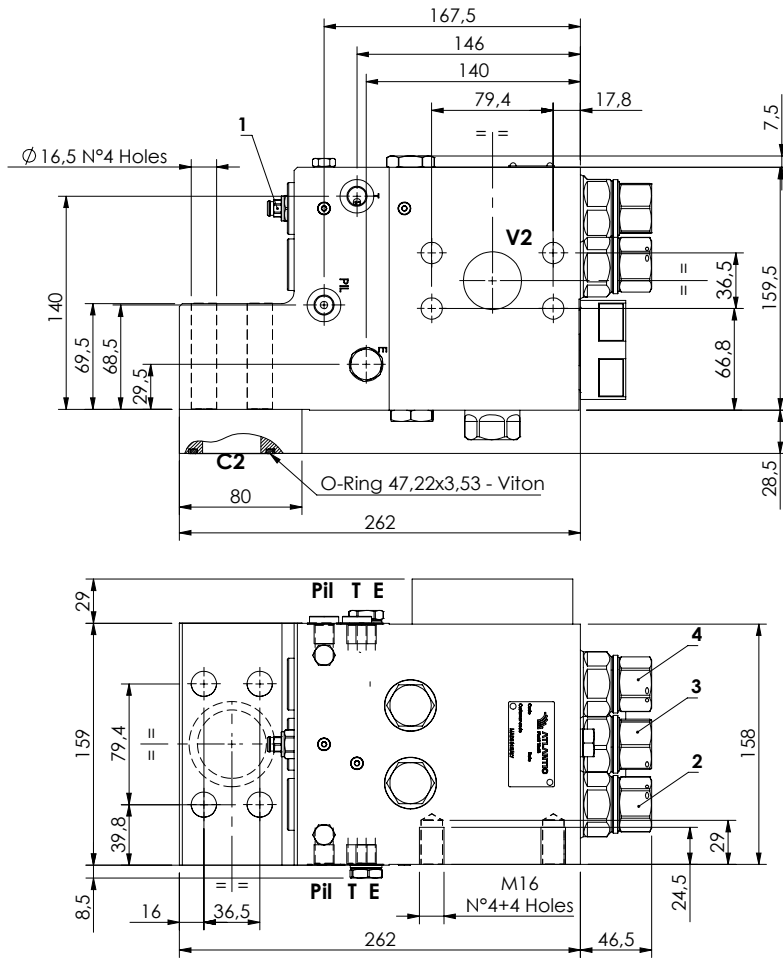

SPECIFICATIONS

Max. operating pressure:	420 bar
Rated flow:	1400 l/min
Manifold:	Steel
Weight:	43,18 kg

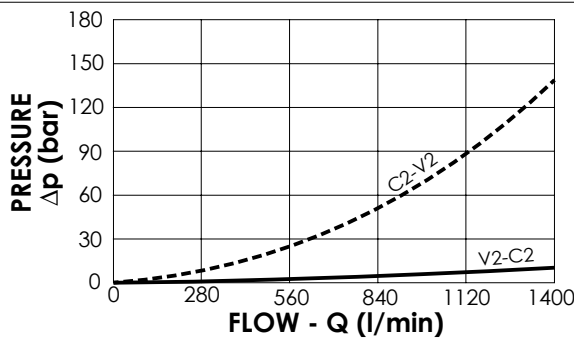

NOTES

When correctly adjusted for the special excavator installation, these valves meet the requirement of ISO 8643

ORDERING CODES

Quick code	Description	Main ports size	Standard setting (bar)	Adjust. range (bar)	Pressure increase (bar/turn)
ML000162	MLST-1400-AAGN-00-S22-N420	V2,C2:1" 1/2 SAE 6000 E,Pil,T:G 1/4"	① 400 Q=5 l/min ③ 7.5 Crack. pr. ②④ 8.5 Crack. pr.	① 150-420 ②③④ 3-15	① 236 ②③④ 3.4

CHECK AND METERING VALVE

MLST-1400-AAGR

**FLANGED TYPE
2" SAE 6000
RIGHT VERSION**

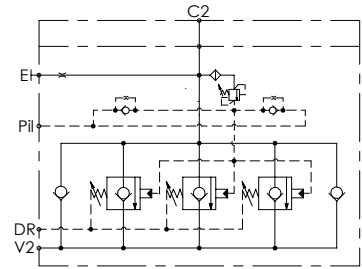
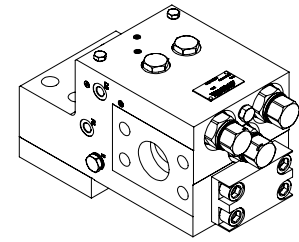
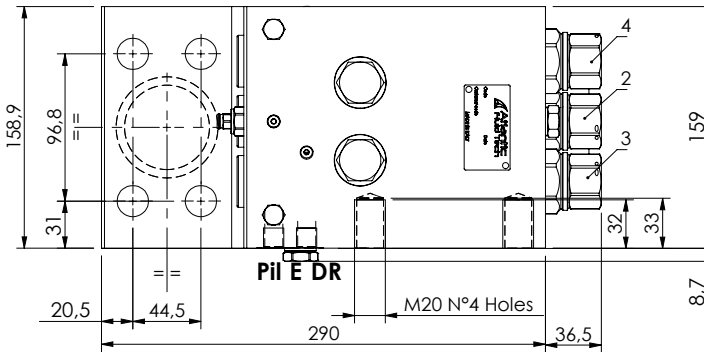
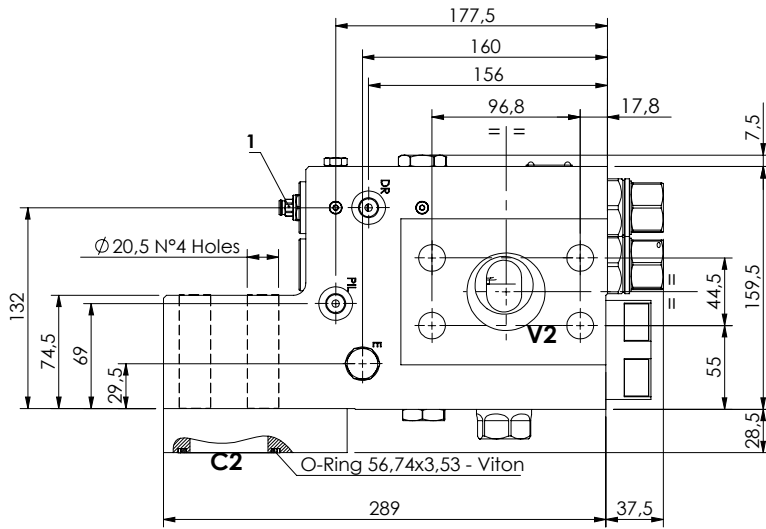

SPECIFICATIONS

Max. operating pressure:	420 bar
Rated flow:	1400 l/min
Manifold:	Steel
Weight:	45,87 kg

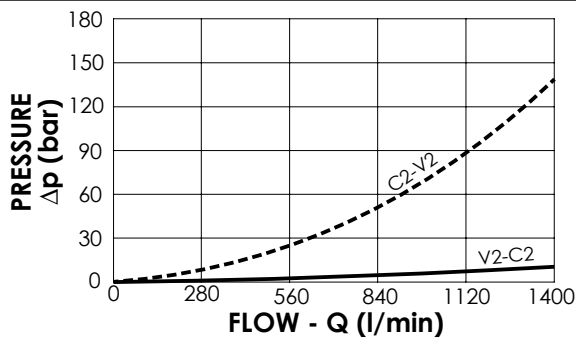

NOTES

When correctly adjusted for the special excavator installation, these valves meet the requirement of ISO 8643

ORDERING CODES

Quick code	Description	Main ports size	Standard setting (bar, Q=5 l/min)	Adjust. range (bar)	Pressure increase (bar/turn)
ML000167	MLST-1400-AAGR-00-S20-N420	V2,C2: 2" SAE 6000 E,Pil,DR: G 1/4"	① 400 Q=5 l/min ② 7,5 Crack. pr. ③ 48,5 Crack. pr.	① 150-420 ② ③ ④ 3-15	① 236 ② ③ ④ 3.4

CHECK AND METERING VALVE

MLST-1400-AAGL

**FLANGED TYPE
2" SAE 6000
LEFT VERSION**

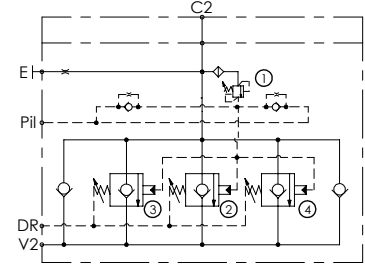
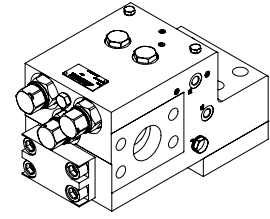
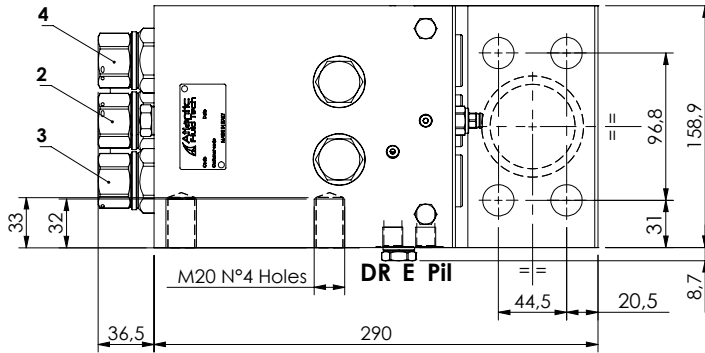
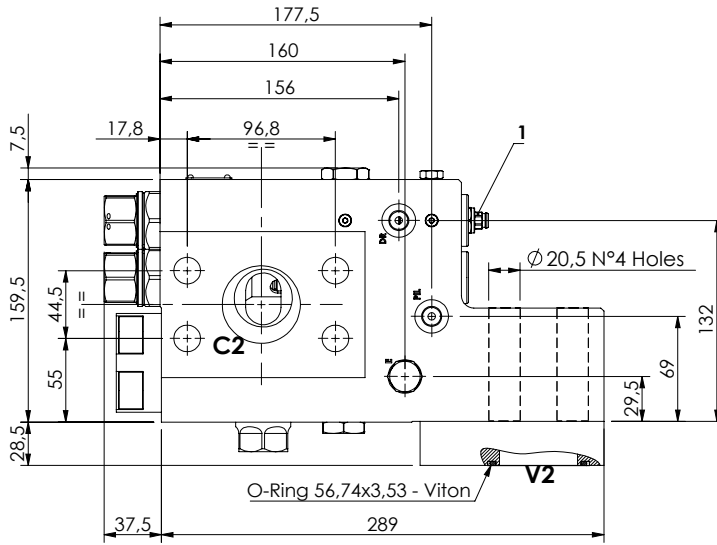

SPECIFICATIONS

Max. operating pressure:	420 bar
Rated flow:	1400 l/min
Manifold:	Steel
Weight:	45,85 kg

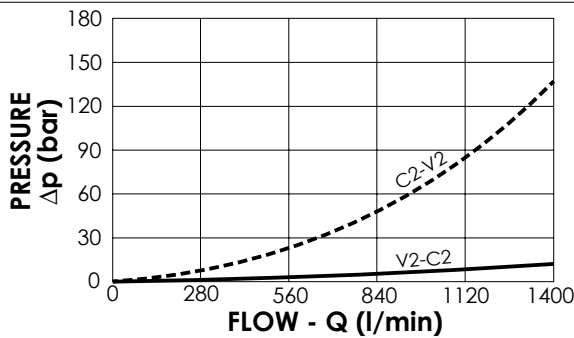

NOTES

When correctly adjusted for the special excavator installation, these valves meet the requirement of ISO 8643

ORDERING CODES

Quick code	Description	Main ports size	Standard setting (bar)	Adjust. range (bar)	Pressure increase (bar/turn)
ML000166	MLST-1400-AAGL-00-S20-N420	V2,C2:2" SAE 6000 E,Pil,T:G 1/4"	① 400 Q=5 l/min ② 7,5 Crack. pr. ③ ④ 8,5 Crack. pr.	① 150-420 ② ③ ④ 3-15	① 236 ② ③ ④ 3.4

CHECK AND METERING VALVE

MLST-1500-AAGR

**FLANGED TYPE
3" SAE 3000 / 2" SAE 6000
RIGHT VERSION**

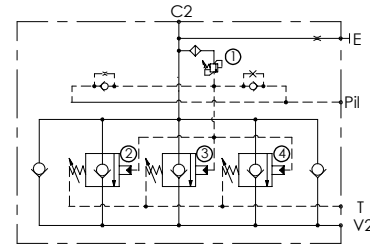
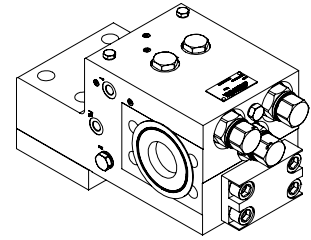
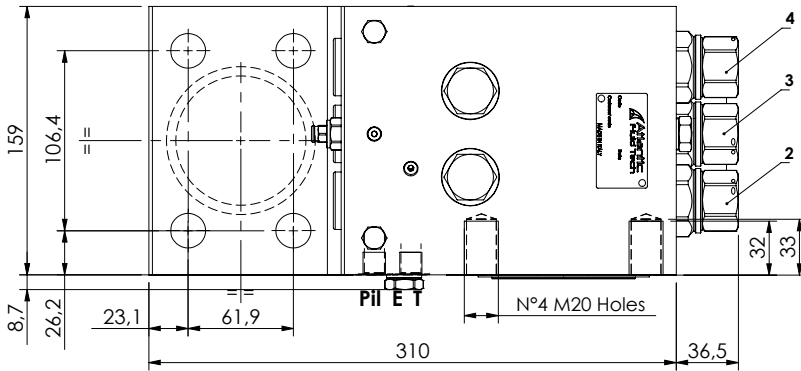
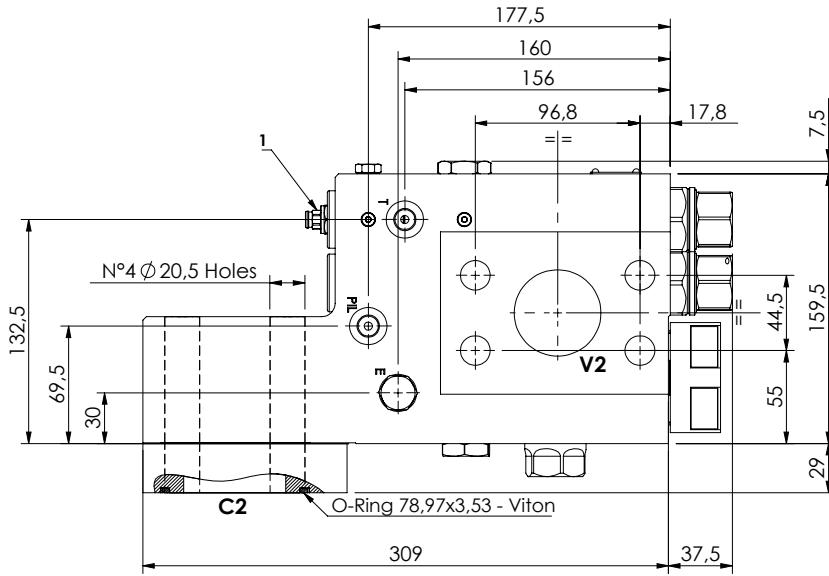

SPECIFICATIONS

Max. operating pressure:	420 bar
Rated flow:	1500 l/min
Manifold:	Steel
Weight:	47,16 kg

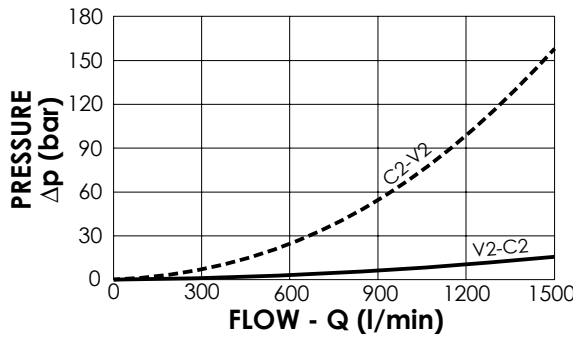

NOTES

When correctly adjusted for the special excavator installation, these valves meet the requirement of ISO 8643

ORDERING CODES

Quick code	Description	Main ports size	Standard setting (bar)	Adjust. range (bar)	Pressure increase (bar/turn)
ML000164	MLST-1500-AAGR-00-S30-N420	V2:2" SAE 6000 C2:3" SAE 3000 E,Pil,T:G 1/4"	① 400 Q=5 l/min ② ④ 8.5 Crack. pr. ③ 7.5 Crack. pr.	① 150-420 ② ③ ④ 3-15	① 236 ② ③ ④ 3.4

CHECK AND METERING VALVE

MLST-1500-AAGL

**FLANGED TYPE
3" SAE 3000 / 2" SAE 6000
LEFT VERSION**

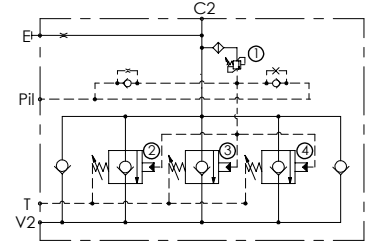
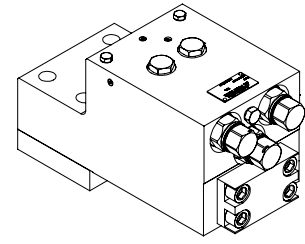
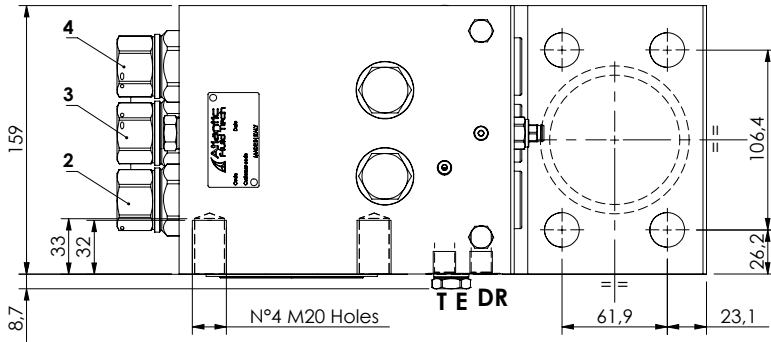
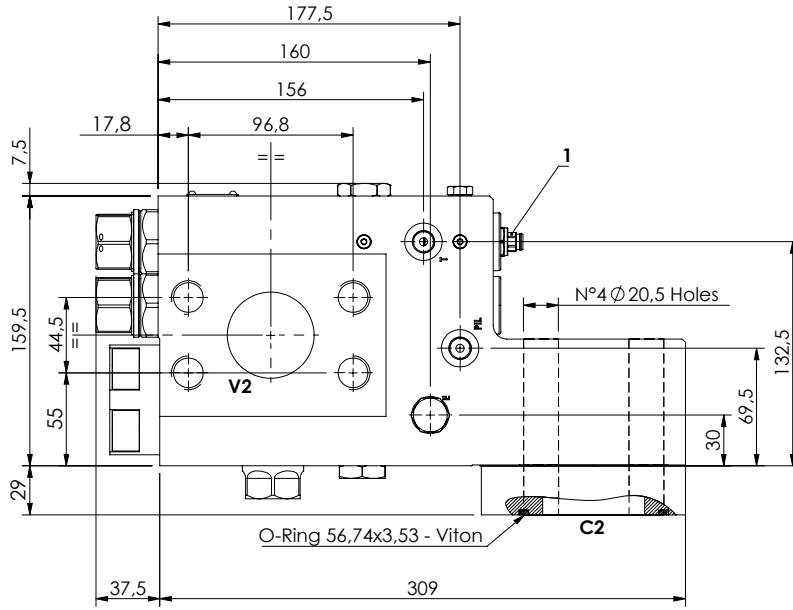

SPECIFICATIONS

Max. operating pressure:	420 bar
Rated flow:	1500 l/min
Manifold:	Steel
Weight:	47,15 kg

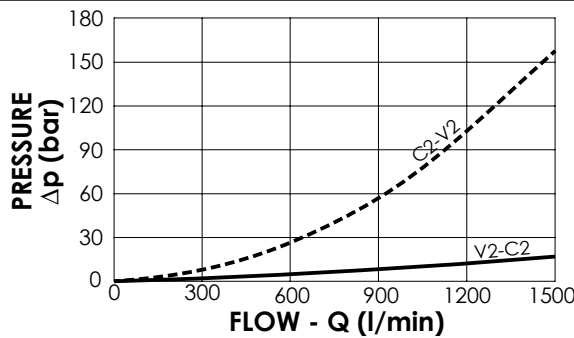

NOTES

When correctly adjusted for the special excavator installation, these valves meet the requirement of ISO 8643

ORDERING CODES

Quick code	Description	Main ports size	Standard setting (bar)	Adjust. range (bar)	Pressure increase (bar/turn)
ML000163	MLST-1500-AAGL-00-S30-N420	V2:2" SAE 6000 C2:3" SAE 3000 E,Pii,T:G 1/4"	① 400 Q=5 l/min ② ④ 8.5 Crack. pr. ③ 7.5 Crack. pr.	① 200-420 ② ③ ④ 3-15	① 236 ② ③ ④ 3.4

CHECK AND METERING VALVE

MLNT-250-AAGN

FLANGE TYPE
3/4" SAE 6000

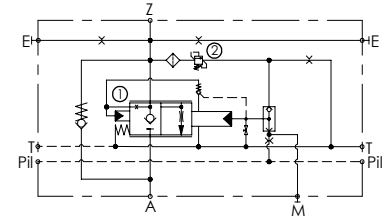
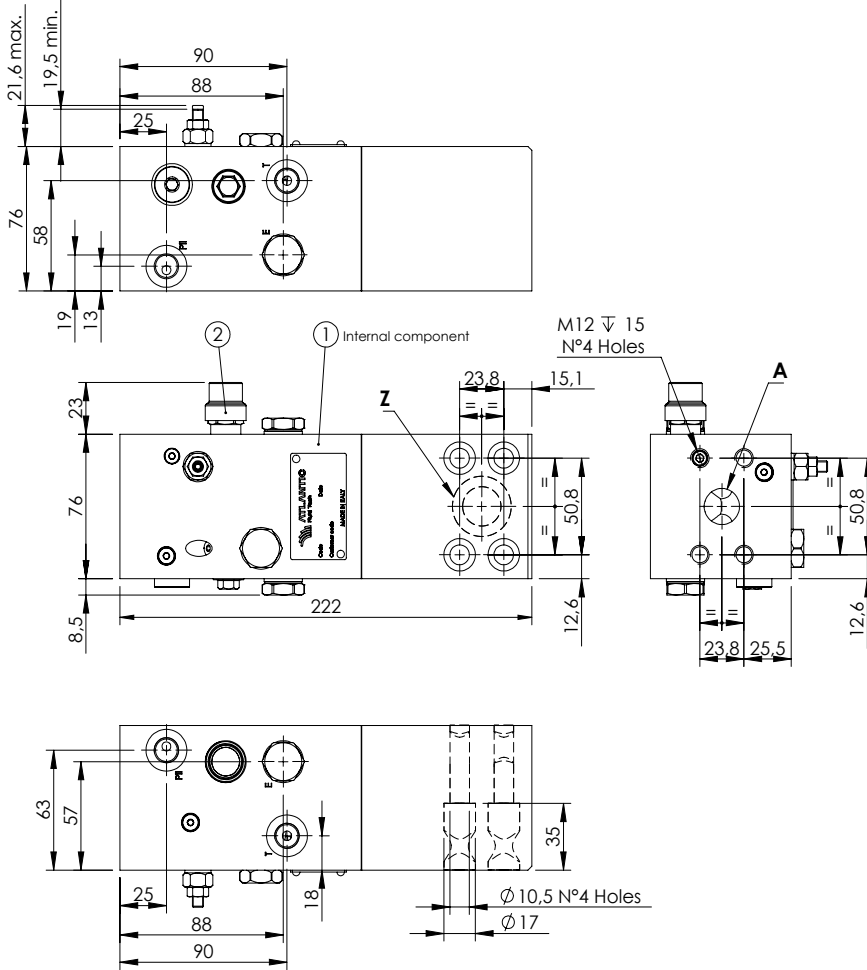
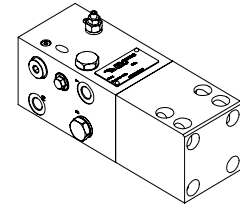

SPECIFICATIONS

Max. operating pressure:	420 bar
Rated flow:	250 l/min
Manifold:	Steel
Weight:	8,31 kg

PATENTED

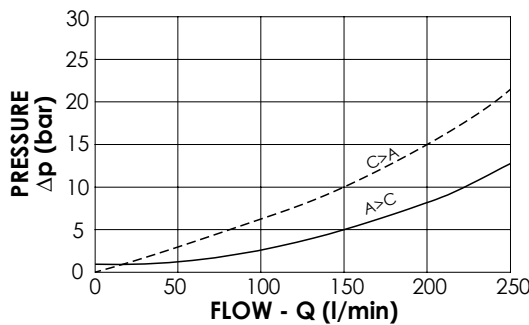

NOTES

When correctly adjusted for the special excavator installation, these valves meet the requirement of ISO 8643

ORDERING CODES

Quick code	Description	Main ports size	Standard setting (bar)	Adjust. range (bar)	Pressure increase (bar/turn)
ML000337	MLNT-250-AAGN-00-S34-N420	Z,A: 3/4" SAE 6000 E,T,Pii,M: G1/4"	① 5,5 Crack. pr. ② 420 Q=5 l/min	① 3 - 10 ② 200 - 420	① 1,8 ② 236

CHECK AND METERING VALVE

MLNT-350-AAGN

**FLANGE TYPE
1" SAE 6000**

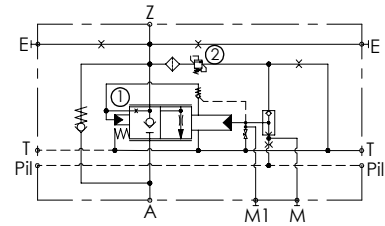
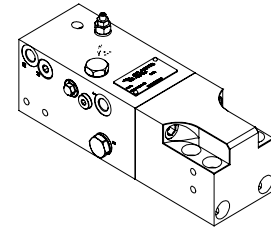
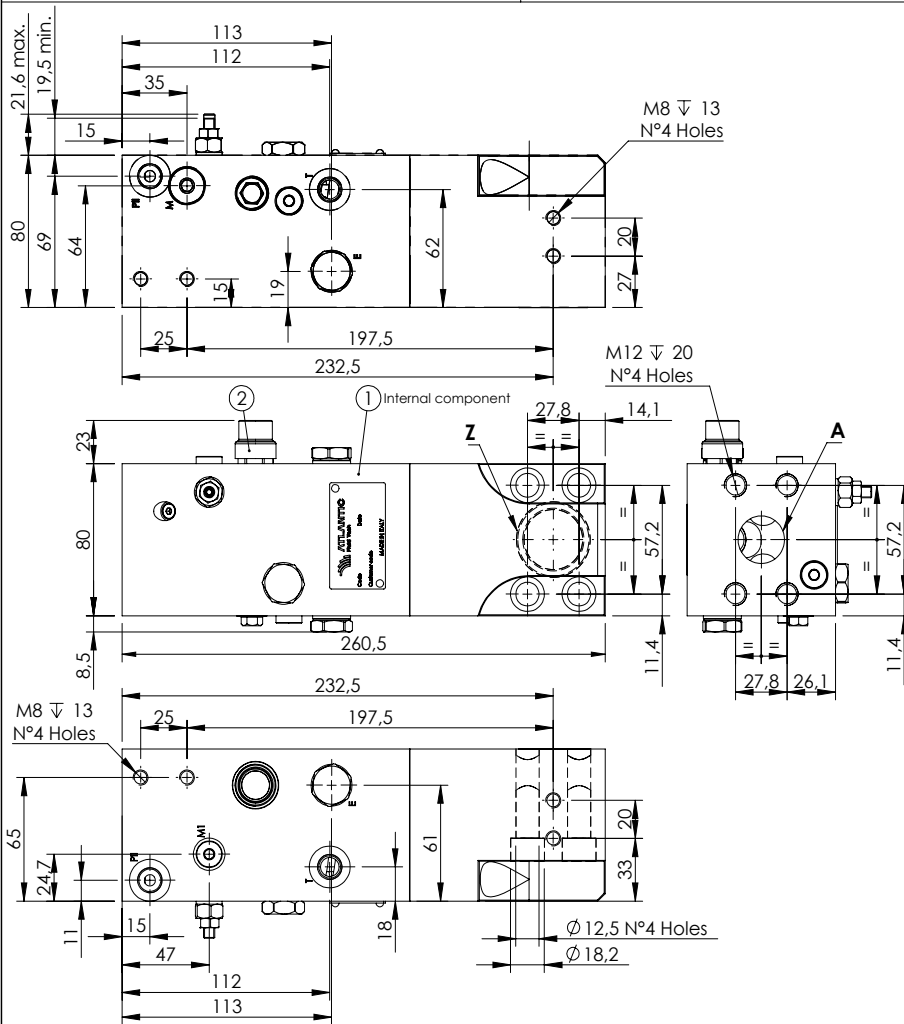

SPECIFICATIONS

Max. operating pressure:	420 bar
Rated flow:	350 l/min
Manifold:	Steel
Weight:	10,18 kg

PATENTED

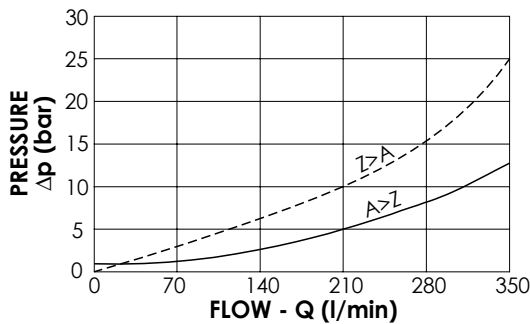

NOTES

When correctly adjusted for the special excavator installation, these valves meet the requirement of ISO 8643

ORDERING CODES

Quick code	Description	Main ports size	Standard setting (bar)	Adjust. range (bar)	Pressure increase (bar/turn)
ML000271	MLNT-350-AAGN-00-S10-N420	Z,A: 1" SAE 6000 E,T,Pil,M: G1/4" M1: G1/8"	① 5,5 Crack. pr. ② 420 Q=5 l/min	① 3 - 17 ② 200 - 420	① 2,4 ② 236

CHECK AND METERING VALVE

MLNT-500-AAGN

**FLANGE TYPE
1"-1/4 SAE 6000**

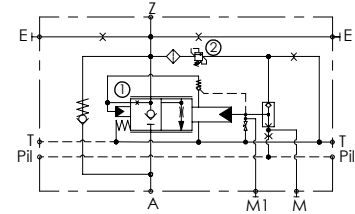
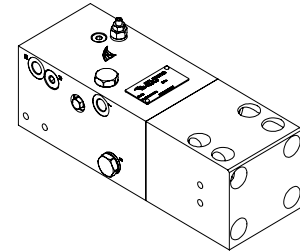
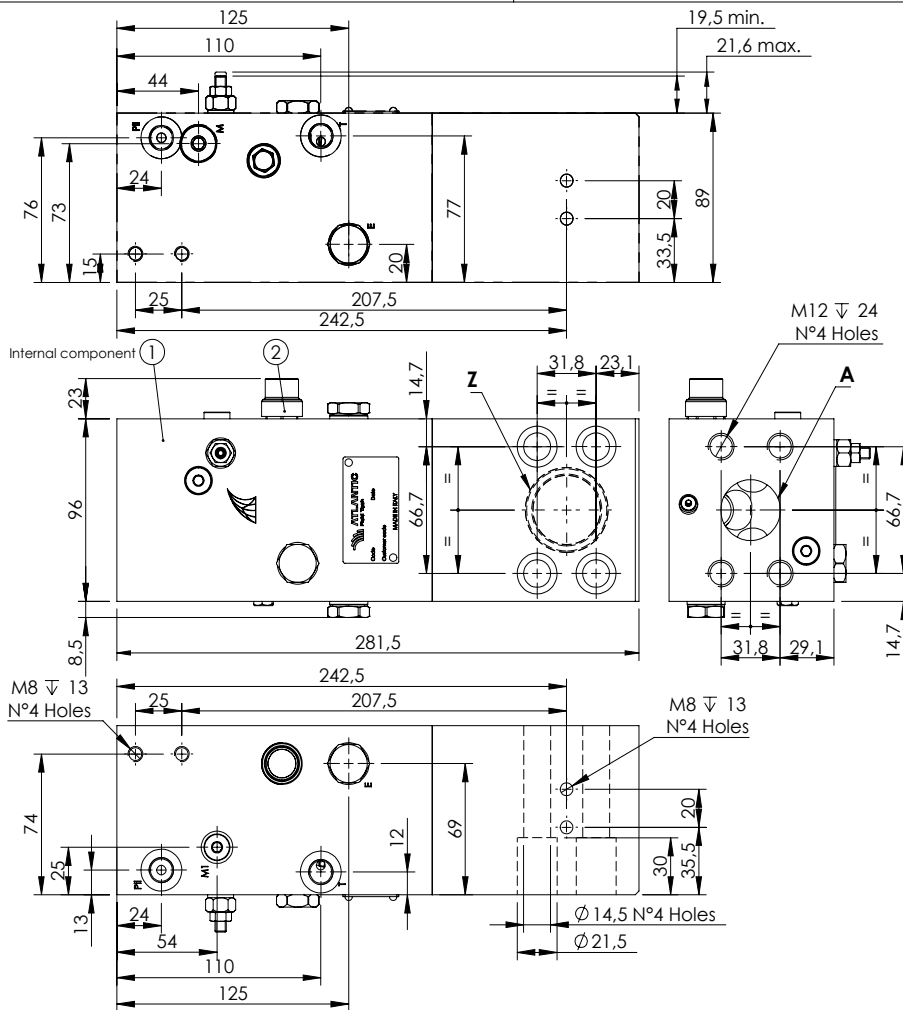

SPECIFICATIONS

Max. operating pressure:	420 bar
Rated flow:	500 l/min
Manifold:	Steel
Weight:	14,9 kg

PATENTED

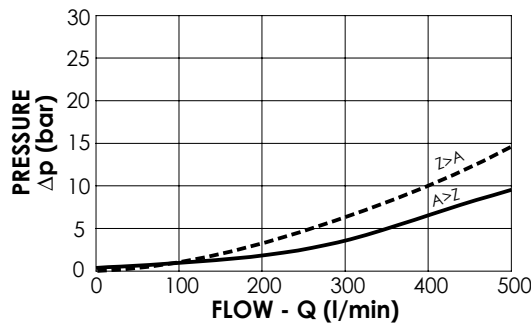

NOTES

When correctly adjusted for the special excavator installation, these valves meet the requirement of ISO 8643

ORDERING CODES

Quick code	Description	Main ports size	Standard setting (bar)	Adjust. range (bar)	Pressure increase (bar/turn)
ML000333	MLNT-500-AAGN-00-S11-N420	Z,A: 1"-1/4 SAE 6000 E,T,Pii,M: G1/4" M1: G1/8"	① 5,5 Crack. pr. ② 420 Q=5 l/min	① 2 - 20 ② 200 - 420	① 2,0 ② 236



1800-OILSOL
1800-645765

<https://oilsolutions.com.au/>

sales@oilsolutions.com.au



ATLANTIC
Fluid Tech

SECTION 11

Shuttle and
Logic
Elements



1800-OILSOL
1800-645765

<https://oilsolutions.com.au/>

sales@oilsolutions.com.au

SECTION 11



SHUTTLE AND LOGIC ELEMENTS

Hydraulic scheme	Valve description	Valve type	Rated flow (l/min)	Max. pressure (bar)	Installation	Main port size or cavity type	Page
	CDSN-005-SSNS	Shuttle	5	350	Insert	VP000018	11.01.010
	CDSN-030-SSNS	Shuttle	30	350	Insert	VP000079	11.01.020
	MDSN-050-SSNR	Shuttle	50	350	In line	G 1/4"	11.01.030
	CDML-040-LBVD	Direct acting, manually operated	40	350	Cartridge	VP000338	11.02.040
	CDLN-040-CCTC	Direct acting, spool type	40	350	Cartridge	SAE-10-3N	11.03.050
	CDLN-040-CCTE	Direct acting, spool type	40	350	Cartridge	SAE-10-3N	11.04.060
	CDLN-040-CCVC	Direct acting, spool type	40	350	Cartridge	SAE-10-3N	11.05.070
	CDLN-040-CCVE	Direct acting, spool type	40	350	Cartridge	SAE-10-3N	11.06.080
	CDLC-150-CCTB	Direct acting, spool type	150	350	Cartridge	SAE-12-4N	11.07.090
	CDLN-040-CDTK	Direct acting, spool type	40	350	Cartridge	SAE-10-4N	11.08.100
	CDLN-040-CDTH	Direct acting, spool type	40	350	Cartridge	SAE-10-4N	11.09.110
	CDLN-040-CDPB	Direct acting, spool type	40	350	Cartridge	SAE-10-4N	11.10.120
	CDLN-120-CDPB	Direct acting, spool type	120	350	Cartridge	SAE-12-4N	11.10.130
	CDLN-100-SCPC	Normally closed, spool type	100	350	Cartridge	VP000198	11.11.140
	CDLN-100-SCPC	Normally closed, spool type, adjustable setting	100	350	Cartridge	VP000198	11.11.150
	CDLN-160-SCTC	Normally closed, spool type	160	350	Cartridge	VP000065	11.11.160
	CDLN-300-SCTC	Normally closed, spool type	300	350	Cartridge	VP000058	11.11.170
	CDLN-500-SCTC	Normally closed, spool type	500	350	Cartridge	VP000178	11.11.180

SECTION 11



SHUTTLE AND LOGIC ELEMENTS

Hydraulic scheme	Valve description	Valve type	Rated flow (l/min)	Max. pressure (bar)	Installation	Main port size or cavity type	Page
	CDLN-100-SCPD	Normally closed, spool type with internal orifice	100	350	Cartridge	VP000198	11.12.190
	CDLN-160-SCTD	Normally closed, spool type with internal orifice	160	350	Cartridge	VP000065	11.12.200
	CDLN-300-SCTD	Normally closed, spool type with internal orifice	300	350	Cartridge	VP000058	11.12.210
	CDLN-500-SCTD	Normally closed, spool type with internal orifice	500	350	Cartridge	VP000178	11.12.220
	CDLN-500-PCPS	Normally closed, poppet type, externally piloted	500	350	Cartridge	VP000189	11.13.230
	CDLN-060-SCPR	Normally open, spool type	60	350	Cartridge	VP000198	11.14.240
	CDLN-100-SBPE	Normally open, spool type	100	350	Cartridge	VP000330	11.15.250
	CDLN-200-SBPE	Normally open, spool type	200	350	Cartridge	VP000204	11.15.260
	CDLN-380-SBPE	Normally open, spool type	380	350	Cartridge	VP000330	11.15.270
	CDLN-160-SCTS	Normally closed, spool type, kick down type	160	350	Cartridge	VP000065	11.16.280

SHUTTLE VALVE

CDSN-005-SSNS

INSERT TYPE

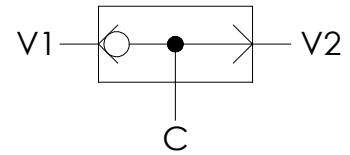
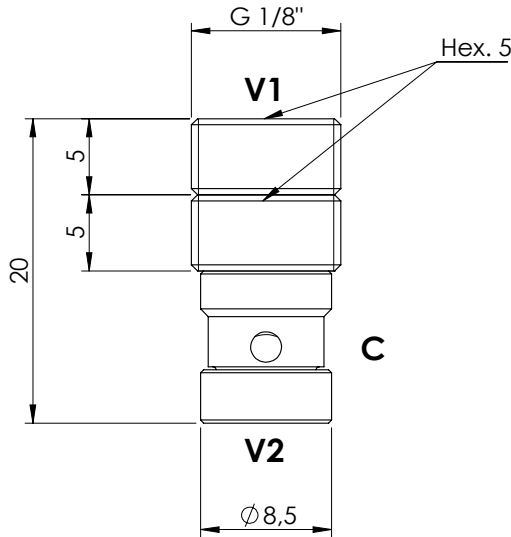
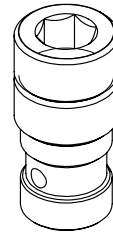

SPECIFICATIONS

Max. operating pressure:	350 bar
Rated flow:	5 l/min
Cavity:	VP000018
Weight:	0,01 kg

NOTES

Installation torque:	12-15 Nm
----------------------	----------

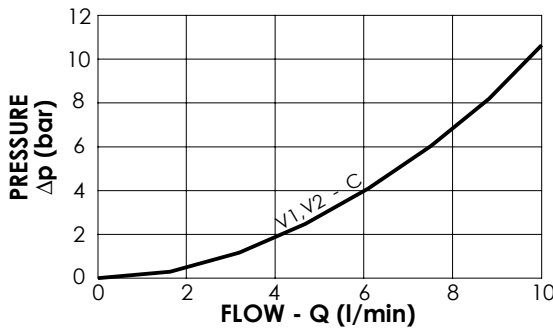

ORDERING CODES

Quick code	Description
CD000001	CDSN-005-SSNS-FN-018-N000

SHUTTLE VALVE

CDSN-030-SSNS

INSERT TYPE

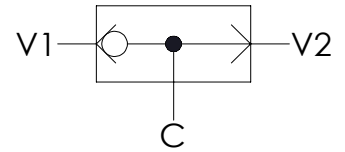
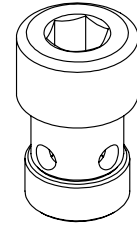
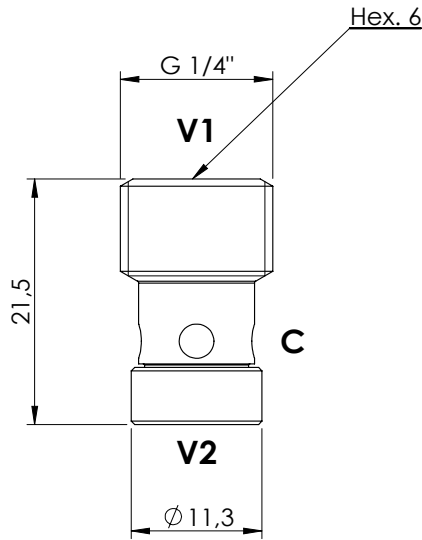

SPECIFICATIONS

Max. operating pressure:	350 bar
Rated flow:	30 l/min
Cavity:	VP000079
Weight:	0,01 kg

NOTES

Installation torque:	14 - 16 Nm
----------------------	------------

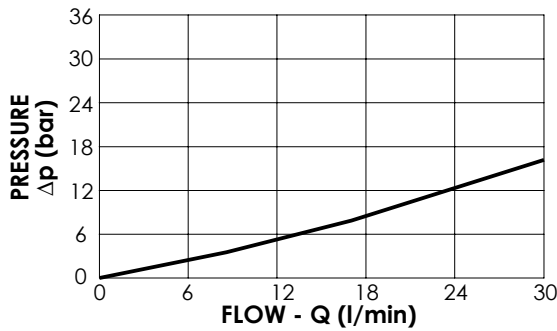

ORDERING CODES

Quick code	Description
CD000045	CDSN-030-SSNS-FN-079-N000

SHUTTLE VALVE

MDSN-050-SSNR

IN LINE TYPE

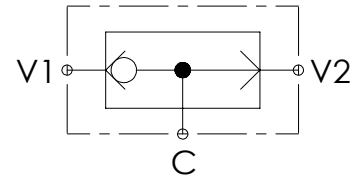
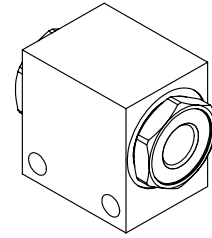
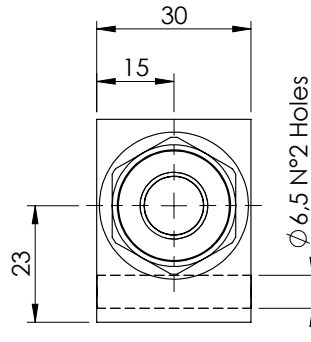
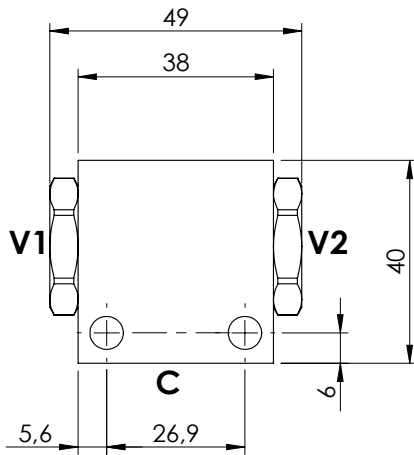
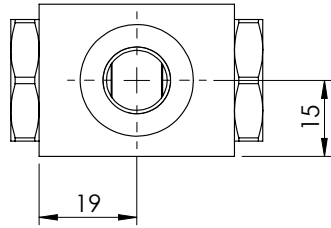

SPECIFICATIONS

Max. operating pressure:	350 bar
Rated flow:	50 l/min
Manifold:	Aluminium
Weight:	0,16 kg

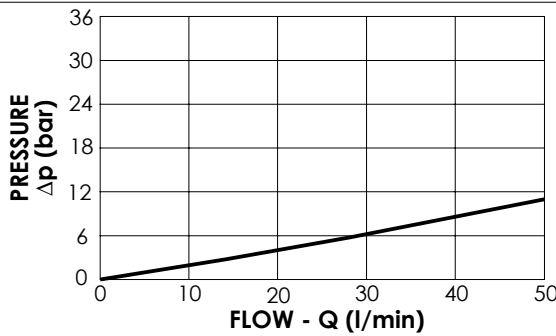

ORDERING CODES

Quick code	Description	Main ports size	
MD000001	MDSN-050-SSNR-NP-G14-N350	G 1/4"	

CARTRIDGE SEAT VALVE

CDML-040-LBVD

**BIDIRECTIONAL SEAT-VALVE SHUT-OFF
DIRECT ACTING
MANUALLY OPERATED**

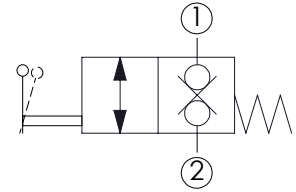
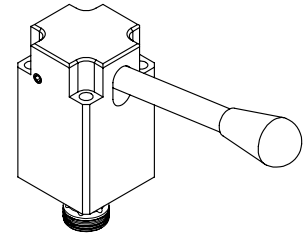
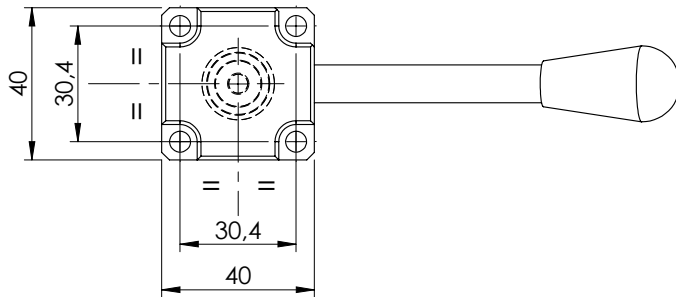
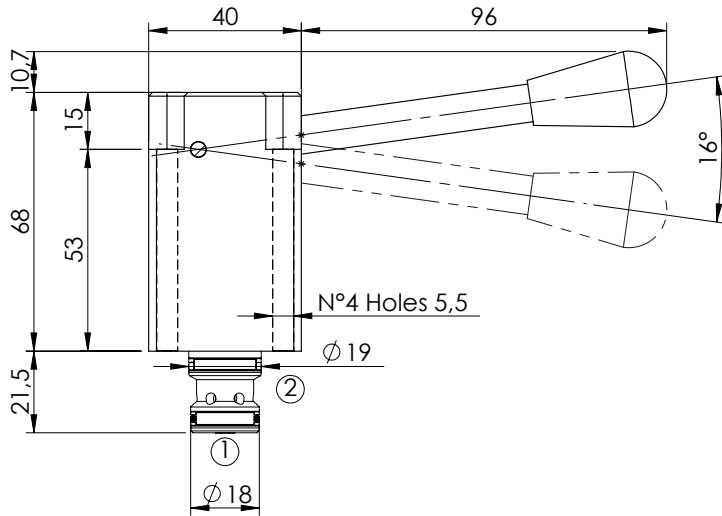

SPECIFICATIONS

Max. operating pressure:	350 bar
Rated flow:	40 l/min
Manifold:	Steel
Weight:	0,8 kg
Seal kit:	RD700338

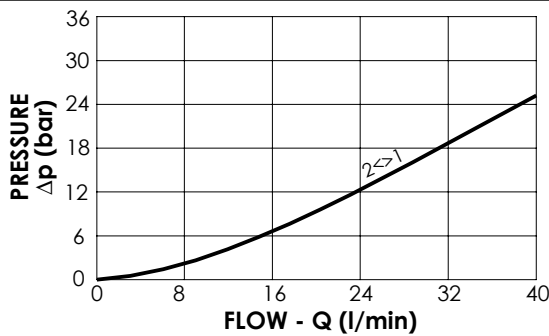

NOTES

To be mounted with M5 x 60 bolt
Installation torque: 5 Nm

ORDERING CODES

Quick code	Description	Cavity
CD000234	CDML-040-LBVD-00-338-N350	VP000338

LOGIC ELEMENT

CDLN-040-CCTC

DIRECT ACTING
SPOOL TYPE

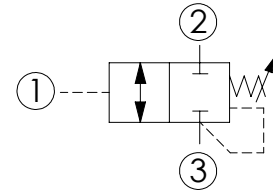
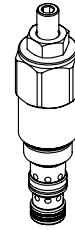
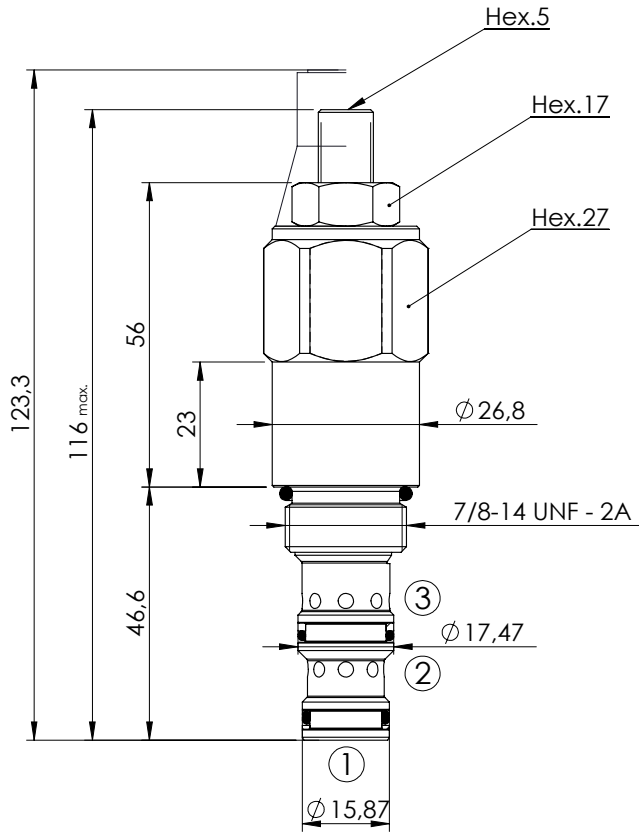

SPECIFICATIONS

Max. operating pressure:	350 bar
Rated flow:	40 l/min
Cavity:	SAE-10-3N
Weight:	0,29 kg
Installation torque:	55 - 62 Nm
Seal kit:	RB700092

SEALING CAP

Ordering code:
AT000022



OPTIONS

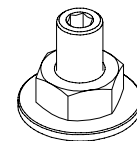

**Adjustment
with Screw**

Pressure in port 3 is additive to setting 1:1. For back pressure compensated valve consult CDLN-040-CCVC data sheet. No O-ring on 1

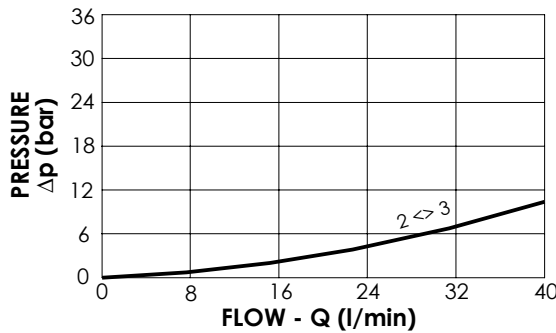

ORDERING CODES

Quick code	Description	Standard setting (bar, Q=5 l/min)	Adjust. range (bar)	Pressure increase (bar/turn)	Options
CD000121	CDLN-040-CCTC-S10-N060	30	10-60	11	Adjustment with Screw

LOGIC ELEMENT

CDLN-040-CCTE

DIRECT ACTING
SPOOL TYPE

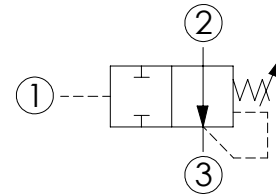
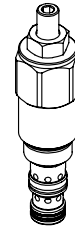
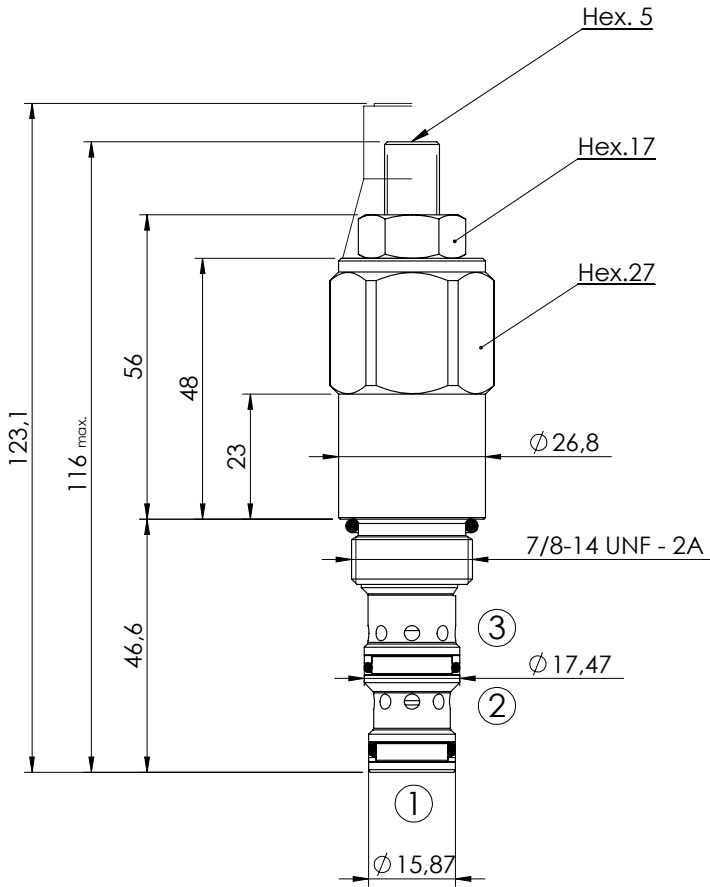

Pressure in port 3 is additive to setting 1:1. For back pressure compensated valve consult CDLN-040-CCVE data sheet. No O-ring on 1

SPECIFICATIONS

Max. operating pressure:	350 bar
Rated flow:	40 l/min
Cavity:	SAE-10-3N
Weight:	0,29 kg
Installation torque:	55 - 62 Nm
Seal kit:	RB700092

SEALING CAP

Ordering code:
AT000022

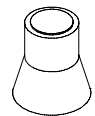

OPTIONS

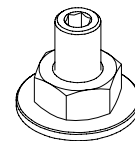

Adjustment
with Screw

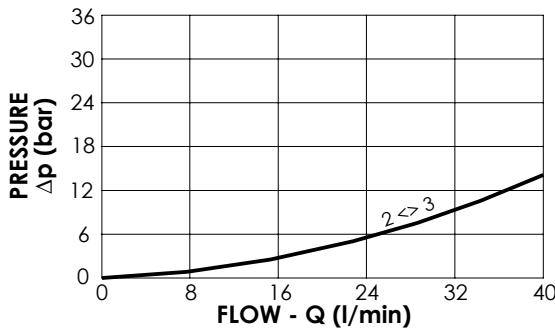

ORDERING CODES

Quick code	Description	Standard setting (bar, Q=5 l/min)	Adjust. range (bar)	Pressure increase (bar/turn)	Options
CD000123	CDLN-040-CCTE-HN-S10-N060	30	10-60	11	Adjustment with Screw

LOGIC ELEMENT

CDLN-040-CCVC SPOOL TYPE - VENTED EXTERNAL PILOT

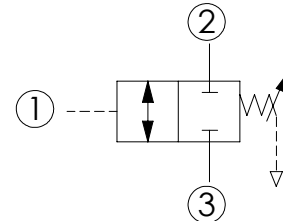
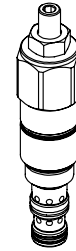
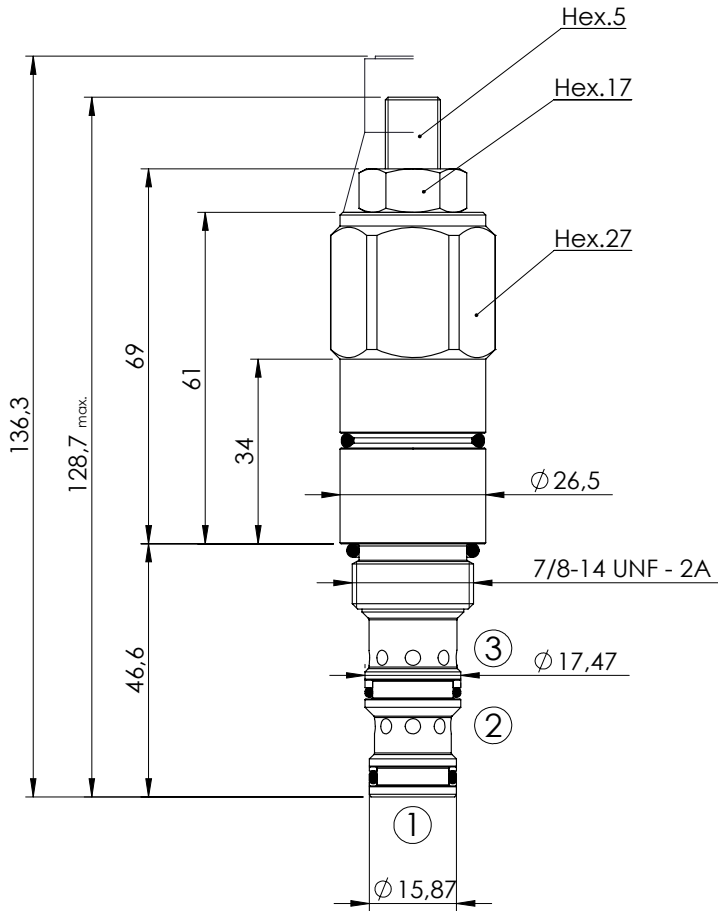

SPECIFICATIONS

Max. operating pressure:	350 bar
Rated flow:	40 l/min
Cavity:	SAE-10-3N
Weight:	0,33 kg
Installation torque:	60 - 75 Nm
Seal kit:	RB700092

SEALING CAP

Ordering code:
AT000022

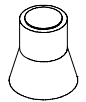

OPTIONS

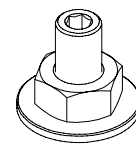

Adjustment with Screw

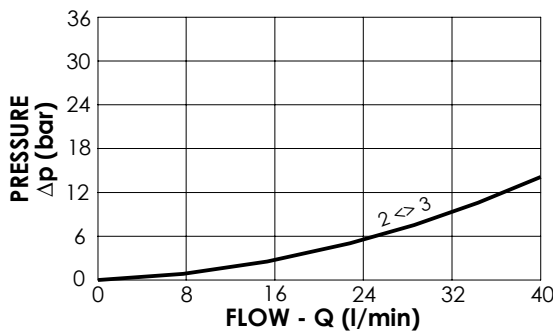

ORDERING CODES

Quick code	Description	Standard setting (bar, Q=5 l/min)	Adjust. range (bar)	Pressure increase (bar/turn)	Options
CD000119	CDLN-040-CCVC-HN-S10-N180	120	20-180	22	Adjustment with Screw
CD000120	CDLN-040-CCVC-HN-S10-N100	50	10-100	10	Adjustment with Screw

LOGIC ELEMENT

CDLN-040-CCVE

SPOOL TYPE - VENTED
EXTERNAL PILOT

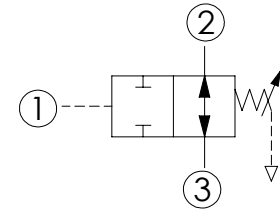
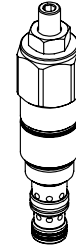
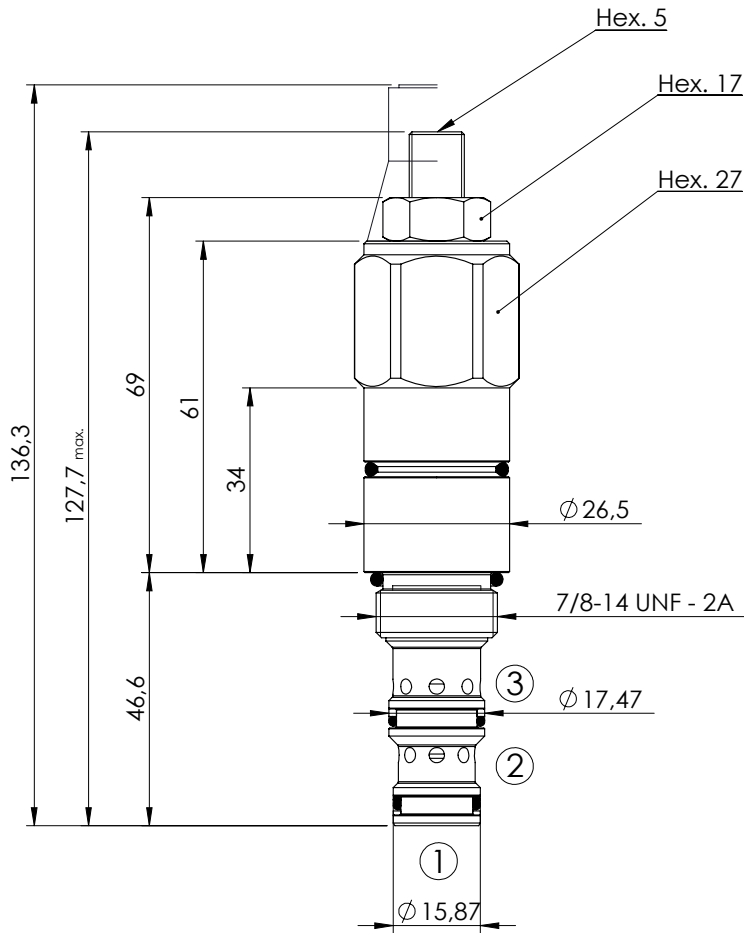

SPECIFICATIONS

Max. operating pressure:	350 bar
Rated flow:	40 l/min
Cavity:	SAE-10-3N
Weight:	0,33 kg
Installation torque:	55 - 62 Nm
Seal kit:	RB700092

SEALING CAP

Ordering code:
AT000021

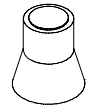

OPTIONS

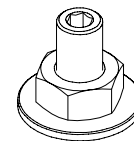

Adjustment
with Screw

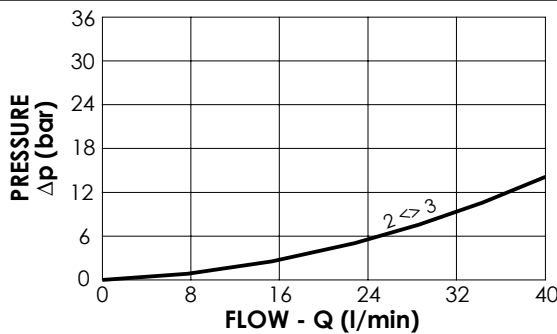

ORDERING CODES

Quick code	Description	Standard setting (bar, Q=5 l/min)	Adjust. range (bar)	Pressure increase (bar/turn)	Options
CD000122	CDLN-040-CCVE-HN-S10-N180	120	20-180	22	Adjustment with Screw
CD000214	CDLN-040-CCVE-HN-S10-N100	50	10-100	10	Adjustment with Screw

LOGIC ELEMENTS

CDLC-150-CCTB

**DIRECT ACTING
SPOOL TYPE**

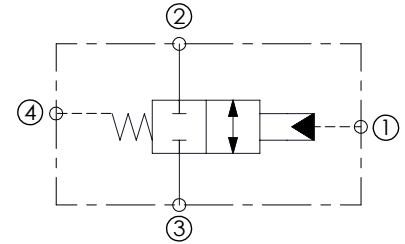
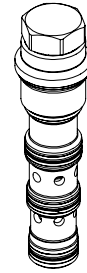
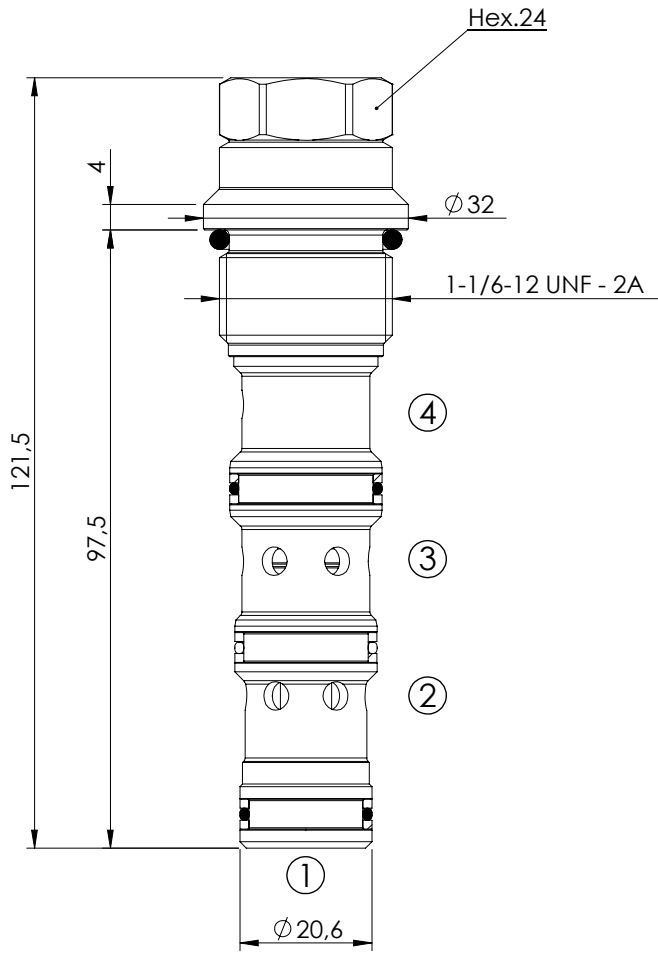

SPECIFICATIONS

Max. operating pressure:	450 bar
Rated flow:	150 l/min
Cavity:	SAE-12-4N
Weight:	0,33 kg

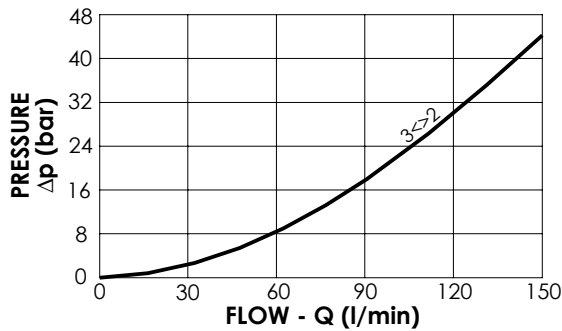

NOTES

Installation torque:	110 - 120 Nm
Seal kit:	RB700103

ORDERING CODES

Quick code	Description	Cracking pressure (bar)	
CD000105	CDLC-150-CCTB-FN-S12-N007	7,5 (0/+2)	

LOGIC ELEMENT

CDLN-040-CDTK

**DIRECT ACTING
SPOOL TYPE**

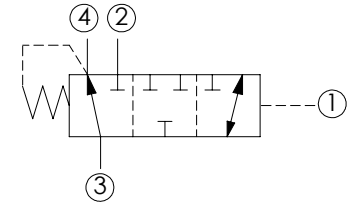
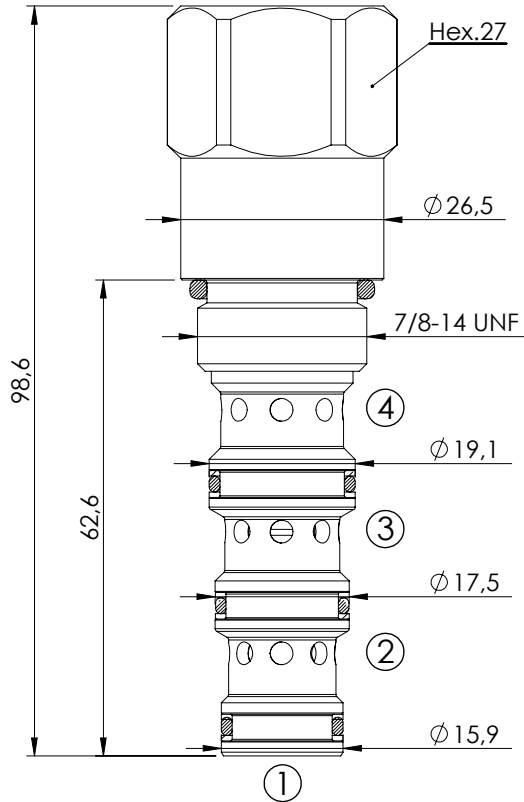
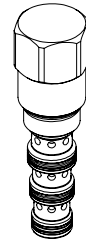

SPECIFICATIONS

Max. operating pressure:	350 bar
Rated flow:	40 l/min
Cavity:	SAE-10-4N
Weight:	0,23 kg
Internal leakage:	50 cc/min

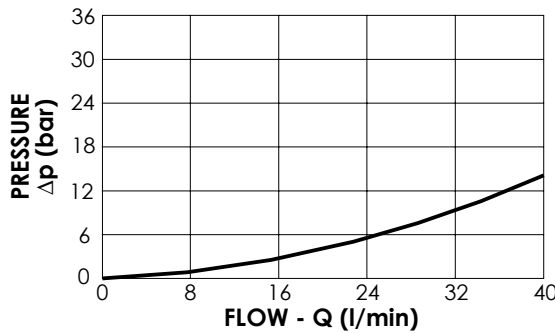

NOTES

Installation torque:	55 - 62 Nm
Seal kit:	RB700102

ORDERING CODES

Quick code	Description	Standard setting (bar, Q=5 l/min)	
CD000300	CDLN-040-CDTK-FN-S10-N003	3 (±1)	
CD000487	CDLN-040-CDTK-FN-S10-N005	5(±1)	
CD000260	CDLN-040-CDTK-FN-S10-N011	11(±1)	

LOGIC ELEMENT

CDLN-040-CDTH

**DIRECT ACTING
SPOOL TYPE**

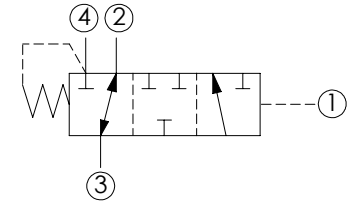
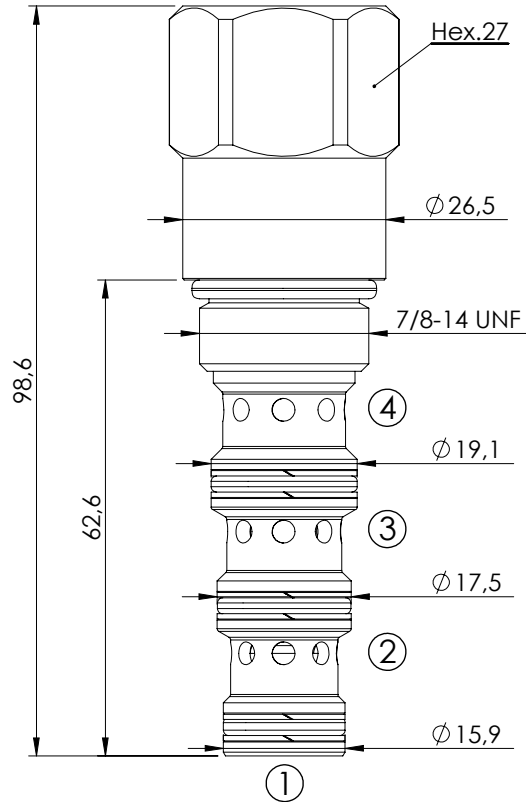
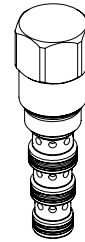

SPECIFICATIONS

Max. operating pressure:	350 bar
Rated flow:	40 l/min
Cavity:	SAE-10-4N
Weight:	0,23 kg
Internal leakage:	50 cc/min

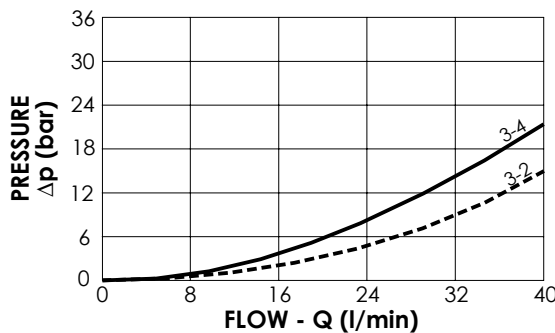

NOTES

Installation torque:	55 - 62 Nm
Seal kit:	RB700102

ORDERING CODES

Quick code	Description	Standard setting (bar, Q=5 l/min)	
CD000377	CDLN-040-CDTH-FN-S10-N003	3 (±1)	
CD000261	CDLN-040-CDTH-FN-S10-N011	11 (±1)	
CD000343	CDLN-040-CDTH-FH-S10-N015	15 (±1)	
CD000276	CDLN-040-CDTH-FH-S10-N030	30 (±1)	
CD000262	CDLN-040-CDTH-FH-S10-N050	50 (±1)	

LOGIC ELEMENT

CDLN-040-CDPB

**DIRECT ACTING
SPOOL TYPE**

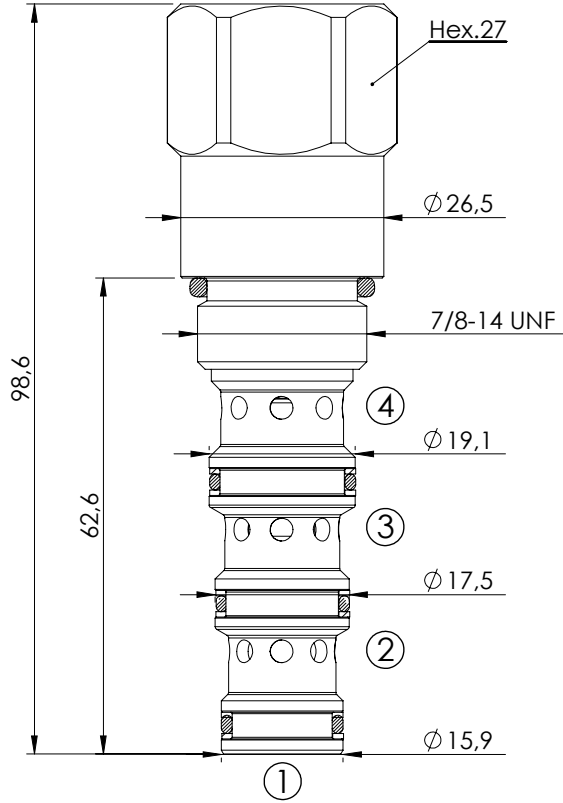
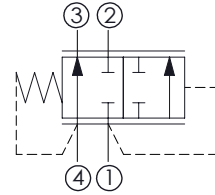
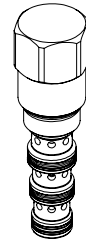

SPECIFICATIONS

Max. operating pressure:	350 bar
Rated flow:	40 l/min
Cavity:	SAE-10-4N
Weight:	0,23 kg
Internal leakage:	50 cc/min

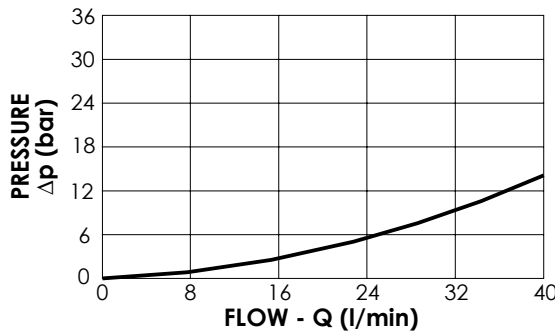

NOTES

Installation torque:	55 - 62 Nm
Seal kit:	RB700102

ORDERING CODES

Quick code	Description	Standard setting (bar, Q=5 l/min)	
CD000295	CDLN-040-CDPB-FH-S10-N005	5 (±0,5)	
CD000296	CDLN-040-CDPB-FH-S10-N011	11,5 (±0,5)	

LOGIC ELEMENTS

CDLN-120-CDPB

DIREC ACTING
SPOOL TYPE

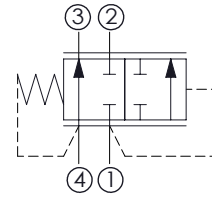
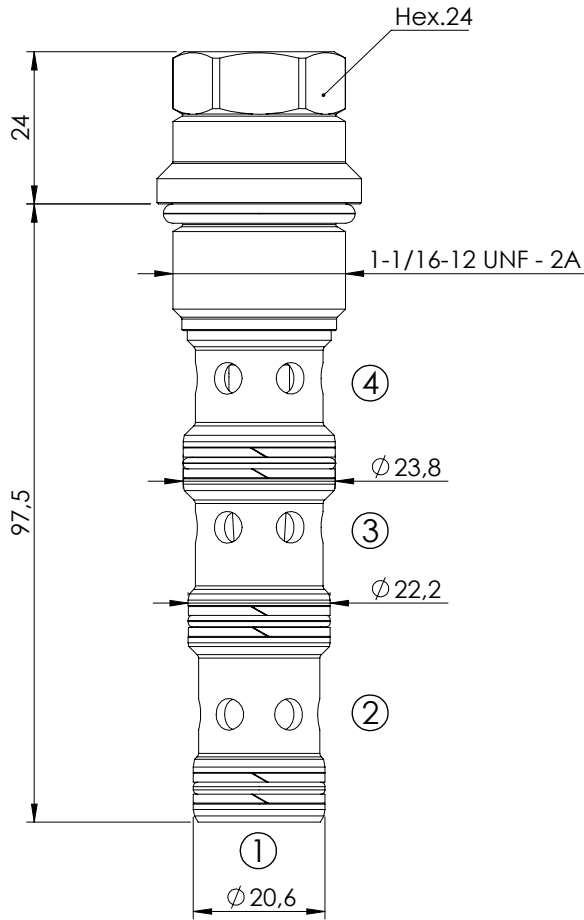

SPECIFICATIONS

Max. operating pressure:	350 bar
Rated flow:	120 l/min
Cavity:	SAE-12-4N
Weight:	0,31 kg

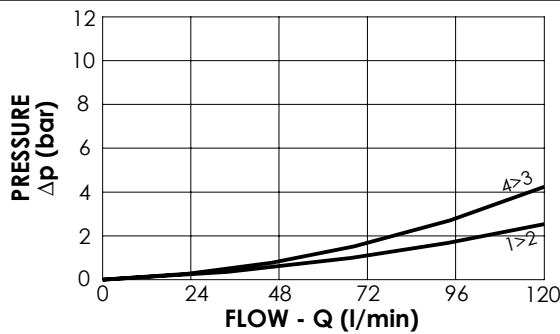

NOTES

Installation torque:	110 - 120 Nm
Seal kit:	RB700103

ORDERING CODES

Quick code	Description	Cracking pressure (bar)	
CD000336	CDLN-120-CDPB-FH-S12-N010	10	

LOGIC ELEMENT

CDLN-100-SCPC

NORMALLY CLOSED
SPOOL TYPE

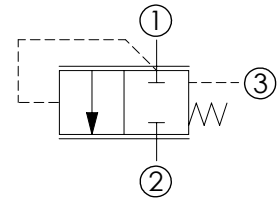
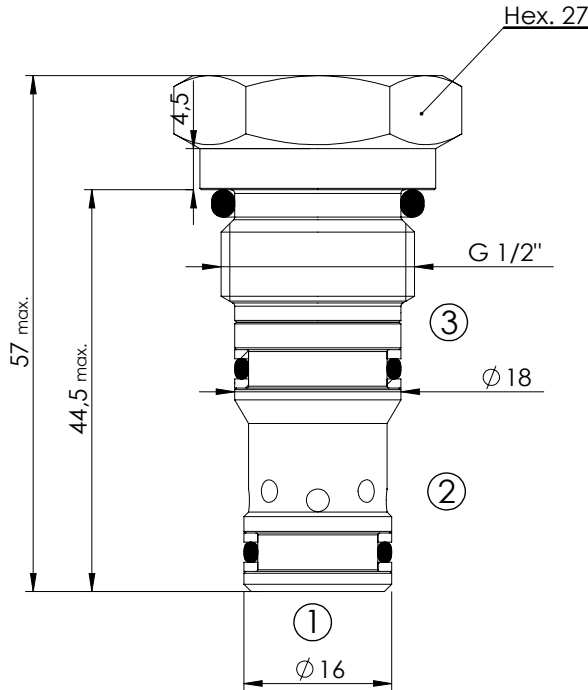
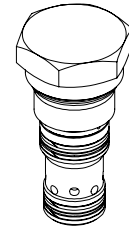

SPECIFICATIONS

Max. operating pressure:	350 bar
Rated flow:	100 l/min
Cavity:	VP000198
Weight:	0,12 kg
Spool:	Ø10 mm

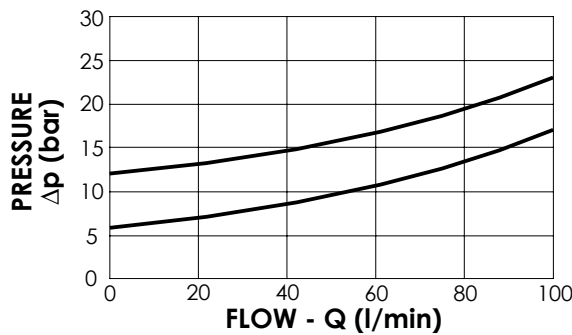

NOTES

Installation torque:	75 - 85 Nm
Seal kit:	RD700198
Parts in body compensator	

ORDERING CODES

Quick code	Description	Cracking pressure (bar)	
CD000073	CDLN-100-SCPC-14-198-N006	6	
CD000103	CDLN-100-SCPC-14-198-N012	12	

LOGIC ELEMENT

CDLN-100-SCPC

**NORMALLY CLOSED
SPOOL TYPE
ADJUSTABLE SETTING**

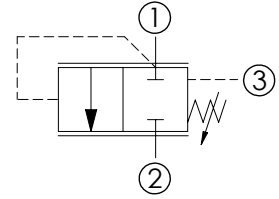
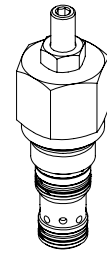
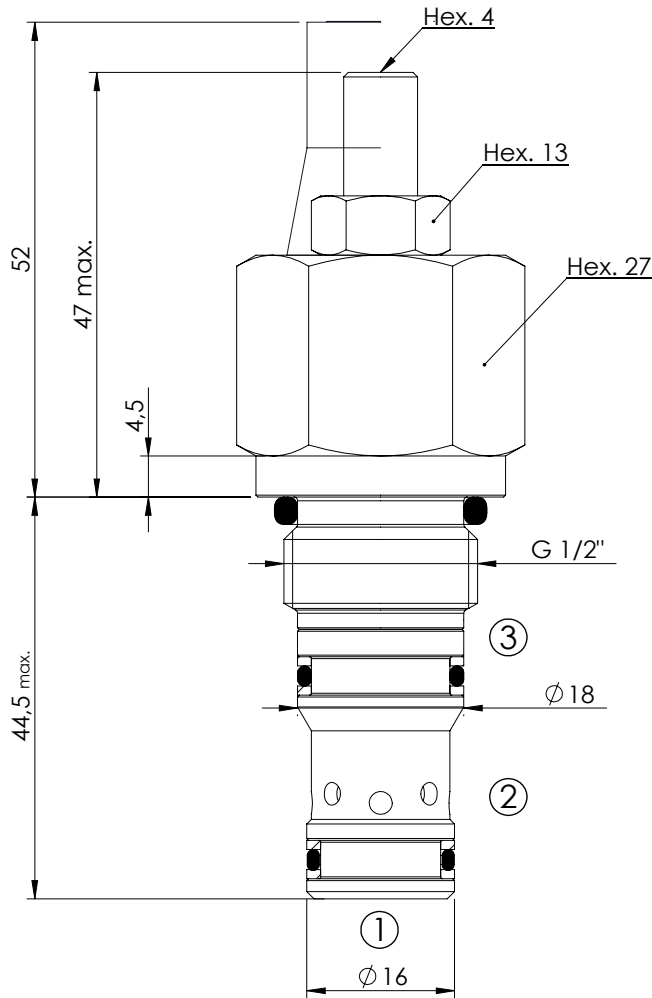

SPECIFICATIONS

Max. operating pressure:	350 bar
Rated flow:	100 l/min
Cavity:	VP000198
Weight:	0,2 kg
Spool:	Ø10 mm

SEALING CAP

Ordering code:
AT000020

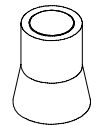

NOTES

Installation torque:	75 - 85 Nm
Seal kit:	RD700198
Parts in body compensator	

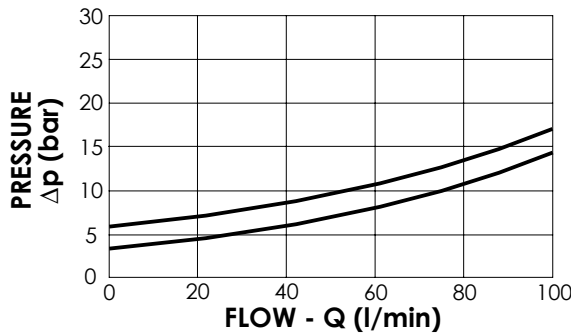

ORDERING CODES

Quick code	Description	Setting range (bar)	
CD000358	CDLN-100-SCPC-01-198-H020	10 - 20	

LOGIC ELEMENT

CDLN-160-SCTC

**NORMALLY CLOSED
SPOOL TYPE**

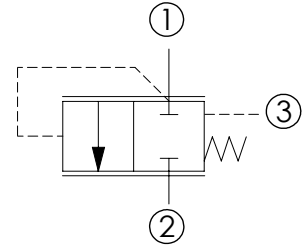
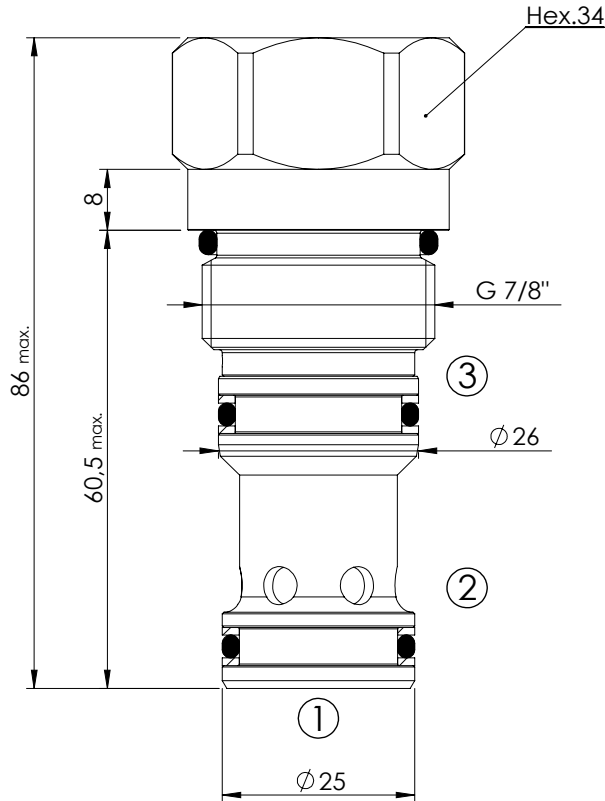
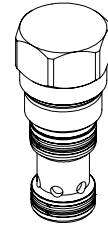

SPECIFICATIONS

Max. operating pressure:	350 bar
Rated flow:	160 l/min
Cavity:	VP000065
Weight:	0,33 kg
Spool:	Ø16 mm

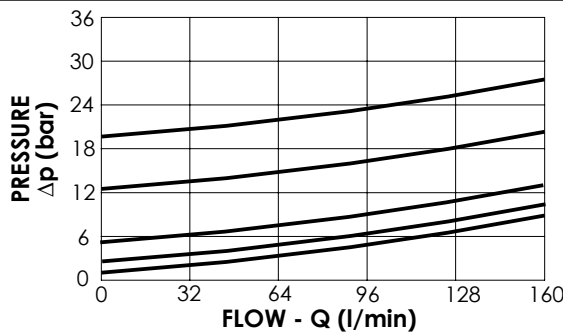

NOTES

Installation torque:	135-145 Nm
Seal kit:	RD900065
Parts in body compensator	

ORDERING CODES

Quick code	Description	Cracking pressure (bar)	
CD000158	CDLN-160-SCTC-14-065-N000	0,4	
CD000076	CDLN-160-SCTC-14-065-N002	2	
CD000051	CDLN-160-SCTC-14-065-N005	5,5	
CD000147	CDLN-160-SCTC-14-065-N012	12,5	
CD000248	CDLN-160-SCTC-14-065-N020	20,5	

LOGIC ELEMENT

CDLN-300-SCTC

**NORMALLY CLOSED
SPOOL TYPE**

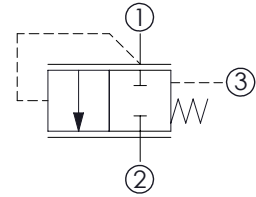
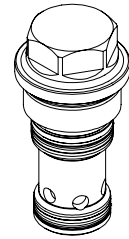
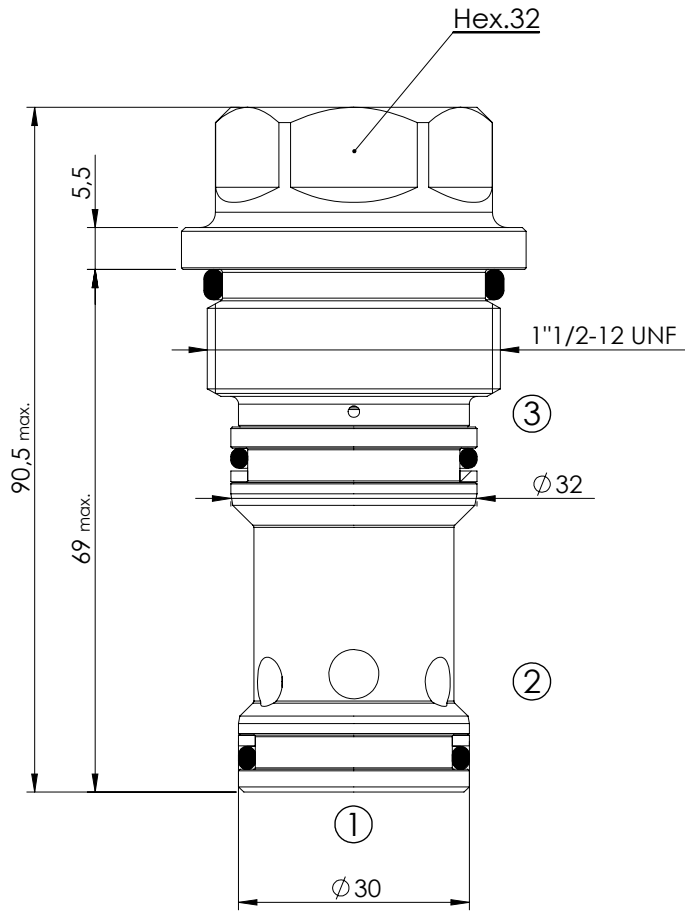

SPECIFICATIONS

Max. operating pressure:	350 bar
Rated flow:	300 l/min
Cavity:	VP000058
Weight:	0,57 kg
Spool:	$\phi 19$ mm

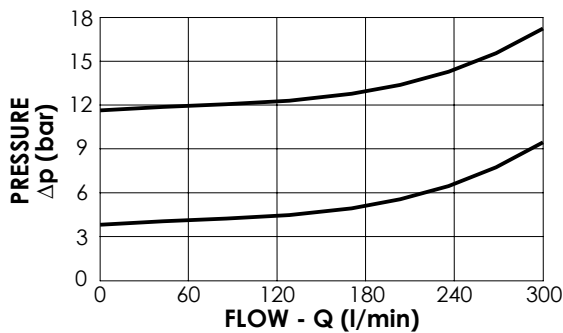

NOTES

Installation torque:	280-300 Nm
Seal kit:	RC700058
Parts in body compensator	

ORDERING CODES

Quick code	Description	Cracking pressure (bar)	
CD000096	CDLN-300-SCTC-14-058-N004	4	
CD000311	CDLN-300-SCTC-14-058-N012	11,5	

LOGIC ELEMENT

CDLN-500-SCTC

NORMALLY CLOSED
SPOOL TYPE

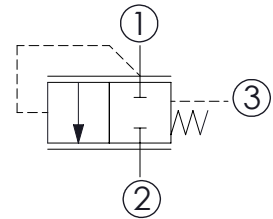
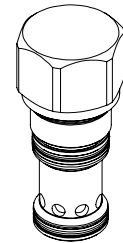
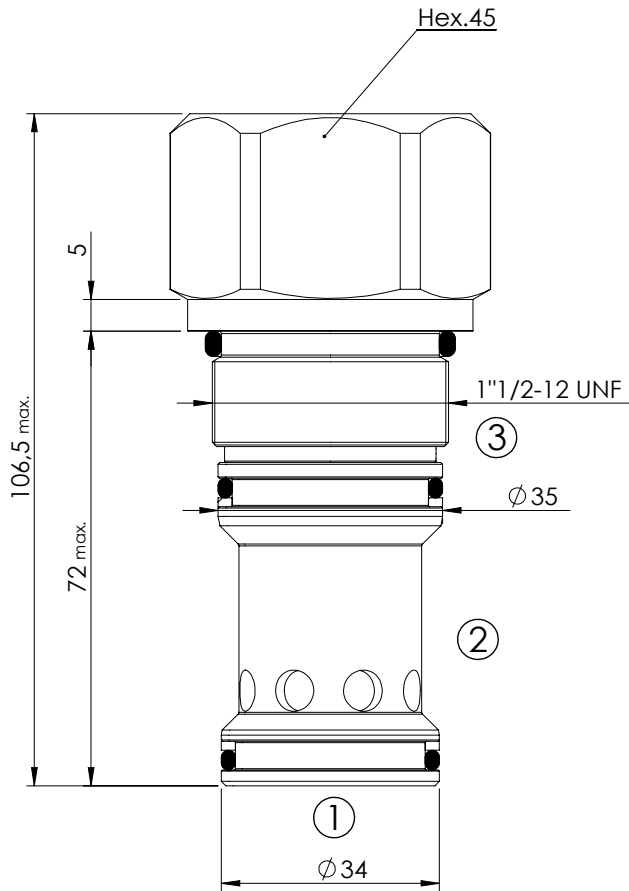

SPECIFICATIONS

Max. operating pressure:	350 bar
Rated flow:	500 l/min
Cavity:	VP000178
Weight:	0,75 kg
Spool:	Ø22 mm

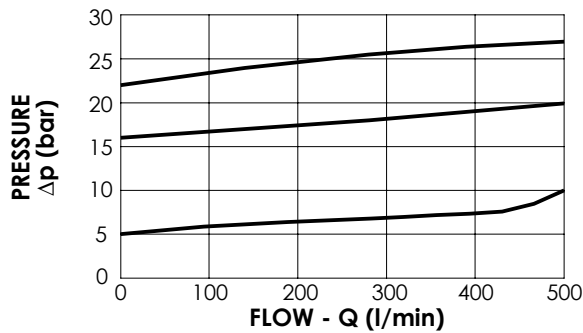

NOTES

Installation torque:	280-300 Nm
Seal kit:	RC700178
Parts in body compensator	

ORDERING CODES

Quick code	Description	Cracking pressure (bar)	
CD000053	CDLN-500-SCTC-14-178-N005	5	
CD000255	CDLN-500-SCTC-14-178-N017	17	
CD000308	CDLN-500-SCTC-14-178-N023	23	

LOGIC ELEMENT

CDLN-100-SCPD

**NORMALLY CLOSED
SPOOL TYPE
WITH INTERNAL ORIFICE**

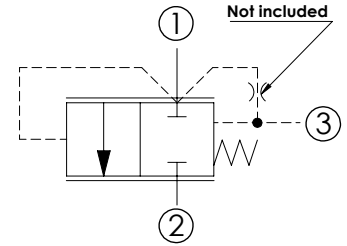
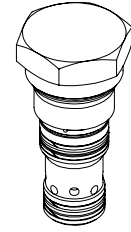
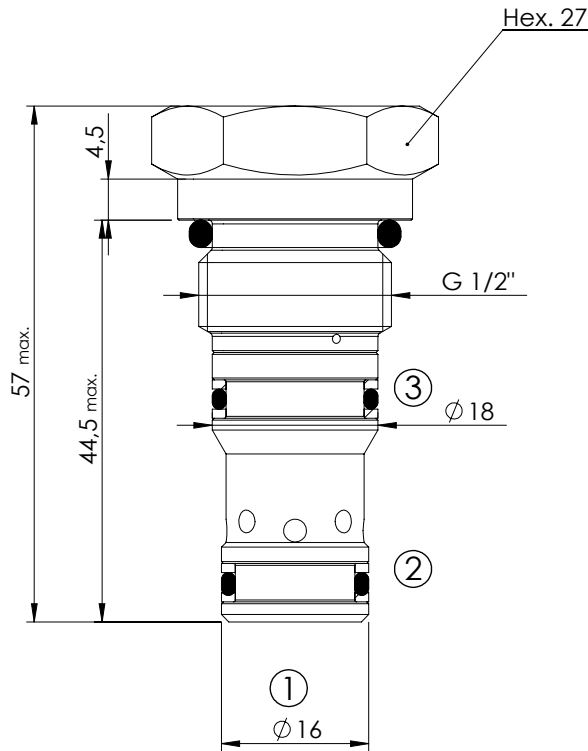

SPECIFICATIONS

Max. operating pressure:	350 bar
Rated flow:	100 l/min
Cavity:	VP000198
Weight:	0,11 kg
Spool:	$\phi 10$ mm
Internal orifice:	M5 thread

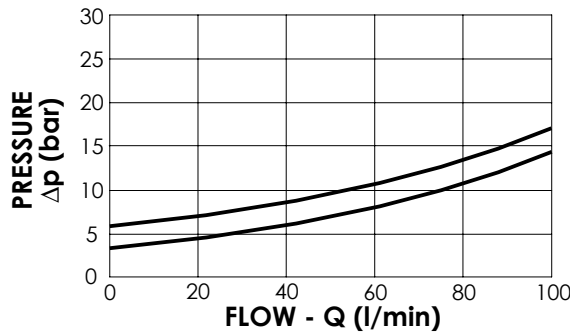

NOTES

Installation torque:	75 - 85 Nm
Seal kit:	RD700198
Parts in body compensator	

ORDERING CODES

Quick code	Description	Cracking pressure (bar)	
CD000216	CDLN-100-SCPD-13-198-N003	3	
CD000215	CDLN-100-SCPD-13-198-N006	6	
CD000220	CDLN-100-SCPD-13-198-N012	12	
CD000238	CDLN-100-SCPD-13-198-N016	16	

LOGIC ELEMENT

CDLN-160-SCTD

**NORMALLY CLOSED
SPOOL TYPE
INTERNAL ORIFICE**

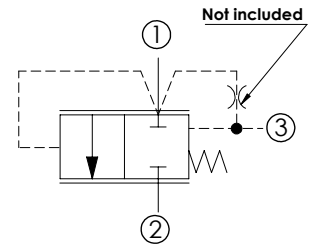
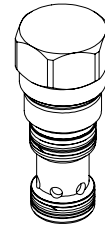
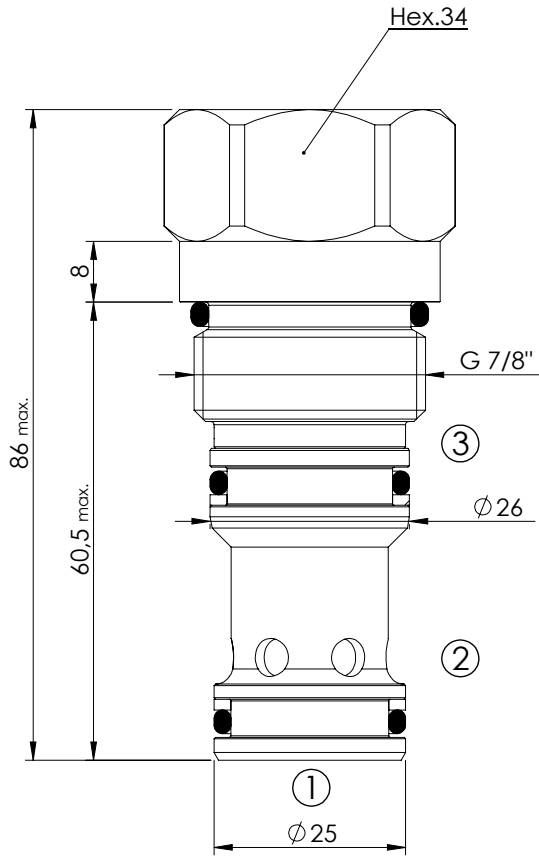

SPECIFICATIONS

Max. operating pressure:	350 bar
Rated flow:	160 l/min
Cavity:	VP000065
Weight:	0,32 kg
Spool:	Ø16 mm
Internal orifice:	M6 thread

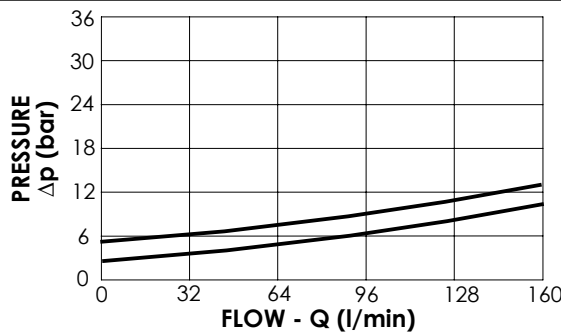

NOTES

Installation torque:	135-145 Nm
Seal kit:	RC900065
Parts in body compensator	

ORDERING CODES

Quick code	Description	Cracking pressure (bar)	
CD000081	CDLN-160-SCTD-13-065-N002	2	
CD000066	CDLN-160-SCTD-13-065-N006	6	
CD000003	CDLN-160-SCTD-13-065-N012	12	
CD000004	CDLN-160-SCTD-13-065-N016	16	

LOGIC ELEMENT

CDLN-300-SCTD

**NORMALLY CLOSED
SPOOL TYPE
INTERNAL RESTRICTOR**

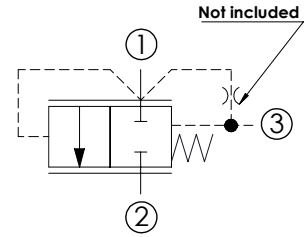
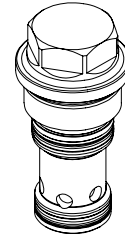
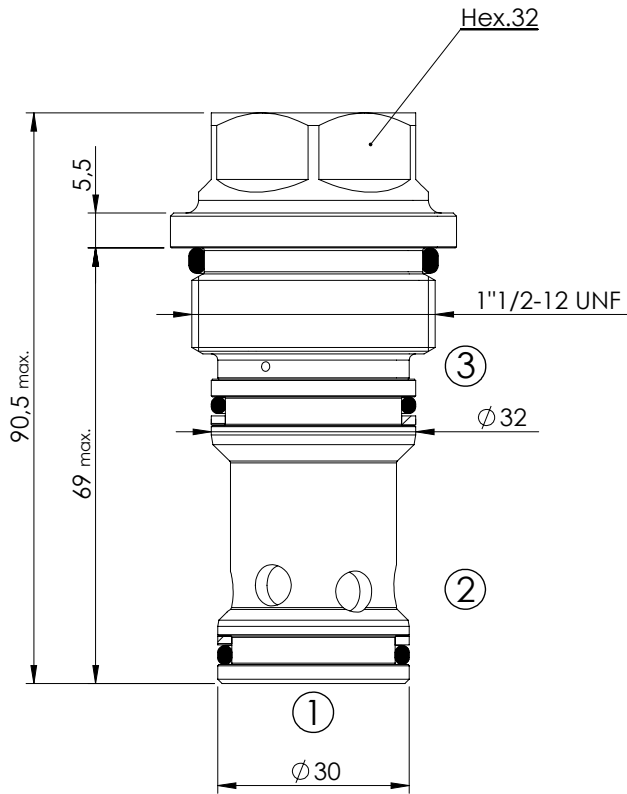

SPECIFICATIONS

Max. operating pressure:	350 bar
Rated flow:	300 l/min
Cavity:	VP000058
Weight:	0,55 kg
Spool:	Ø19 mm
Internal orifice:	M6 thread

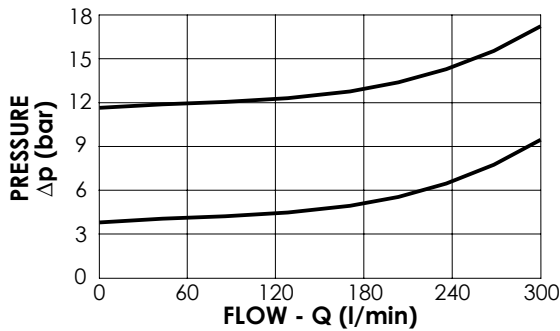

NOTES

Installation torque:	280-300 Nm
Seal kit:	RC700058
Parts in body compensator	

ORDERING CODES

Quick code	Description	Cracking pressure (bar)	
CD000095	CDLN-300-SCTD-13-058-N001	1,5	
CD000110	CDLN-300-SCTD-13-058-N004	4	

LOGIC ELEMENT

CDLN-500-SCTD

**NORMALLY CLOSED
SPOOL TYPE
INTERNAL ORIFICE**

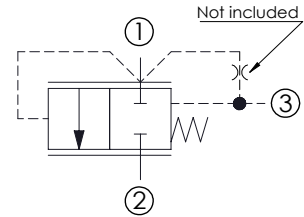
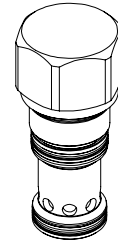
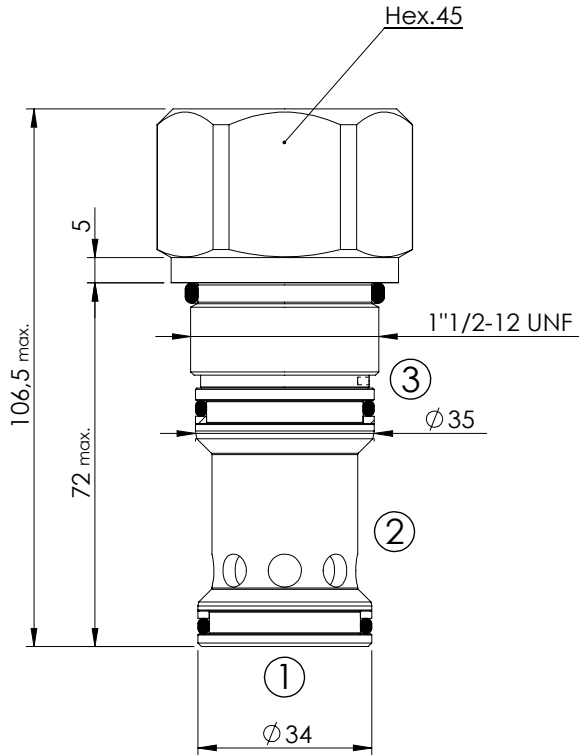

SPECIFICATIONS

Max. operating pressure:	350 bar
Rated flow:	500 l/min
Cavity:	VP000178
Weight:	0,74 kg
Spool:	Ø22 mm
Internal orifice:	M6 thread

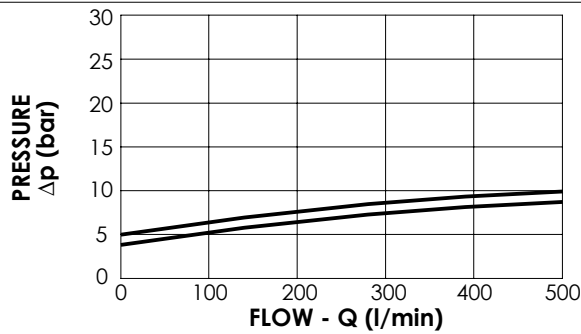

NOTES

Installation torque:	280 - 300 Nm
Seal kit:	RC700178
Parts in body compensator	

ORDERING CODES

Quick code	Description	Cracking pressure (bar)	
CD000067	CDLN-500-SCTD-13-178-N005	5	
CD000335	CDLN-500-SCTD-13-178-N004	4	

LOGIC ELEMENTS

CDLN-500-PCPS

**NORMALLY CLOSED
POPJET TYPE
EXTERNALLY PILOTED**

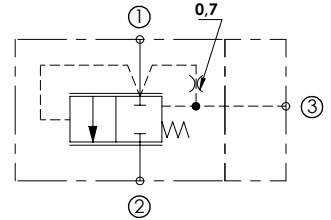
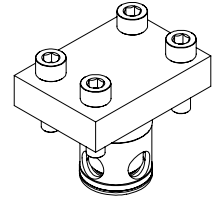
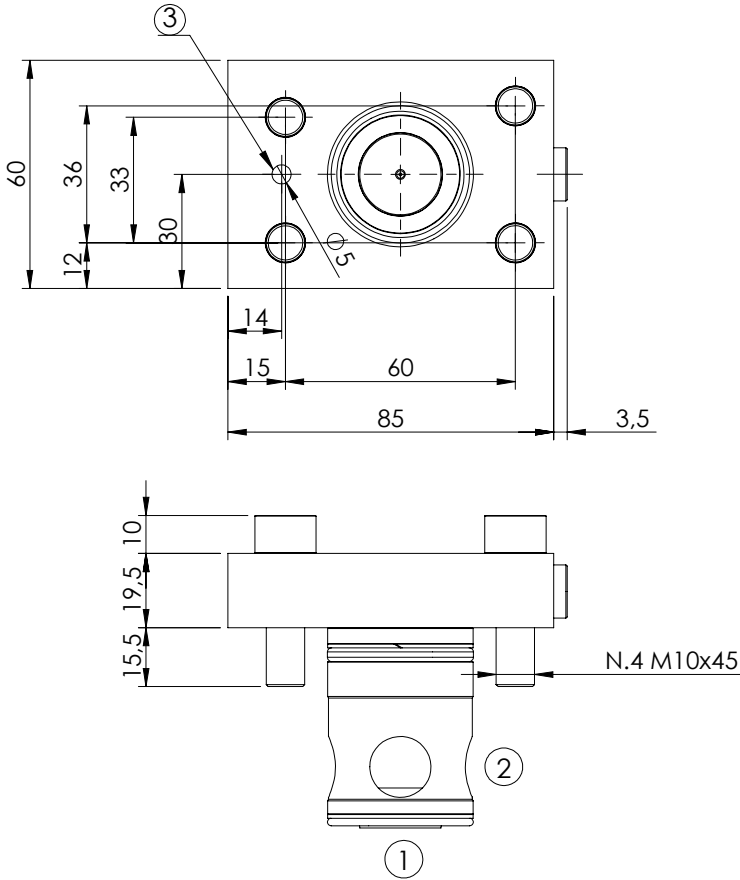

SPECIFICATIONS

Max. operating pressure:	350 bar
Rated flow:	500 l/min
Cavity:	VP000189
Weight:	1,1 kg

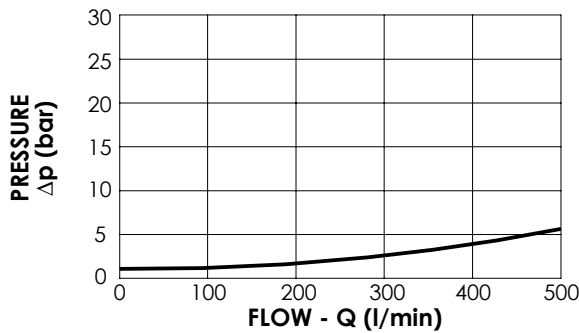

NOTES

Seal kit: RC700189

ORDERING CODES

Quick code	Description	Main ports size	Standard setting (bar, Q=1 l/min)	Configuration
CD000376	CDLN-500-PCPS-01-189-N350	T: G1/8"	1	Logic element + cover
SC000049	SCLN-500-PCPS-01-189-N350			Logic element

LOGIC ELEMENT

CDLN-060-SCPR

**NORMALLY OPEN
SPOOL TYPE**

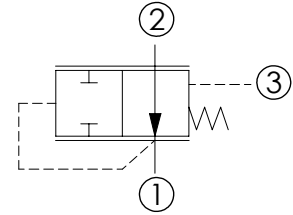
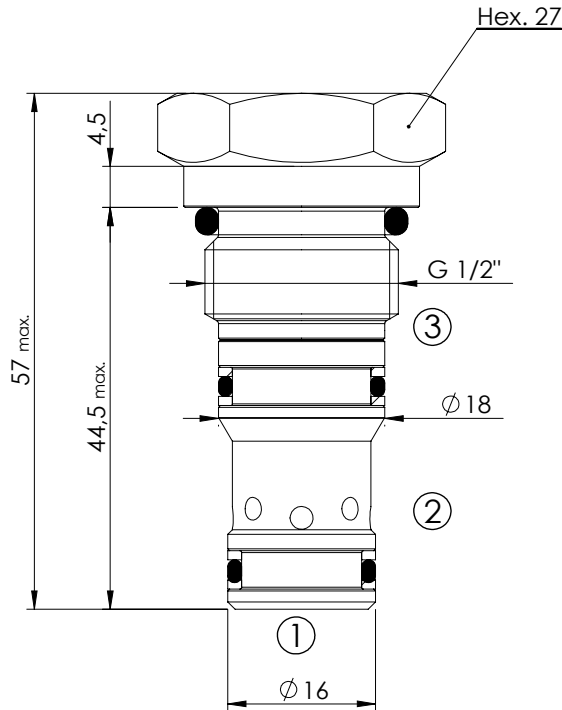
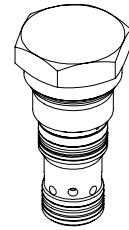

SPECIFICATIONS

Max. operating pressure:	350 bar
Rated flow:	60 l/min
Cavity:	VP000198
Weight:	0,12 kg
Spool:	Ø10 mm

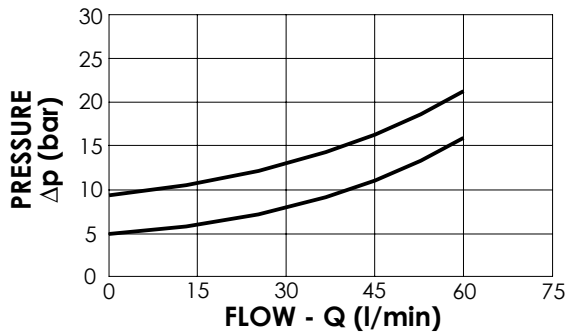

NOTES

Installation torque:	75 - 85 Nm
Seal kit:	RD700198
Parts in body compensator	

ORDERING CODES

Quick code	Description	Closing pressure (bar)	
CD000078	CDLN-060-SCPR-11-198-N005	5	
CD000184	CDLN-060-SCPR-11-198-N009	9,5	

LOGIC ELEMENT

CDLN-100-SBPE

NORMALLY OPEN
SPOOL TYPE

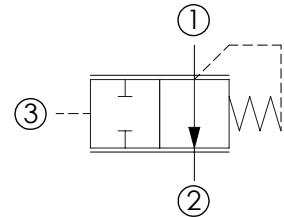
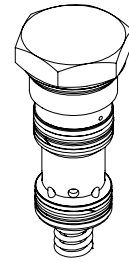
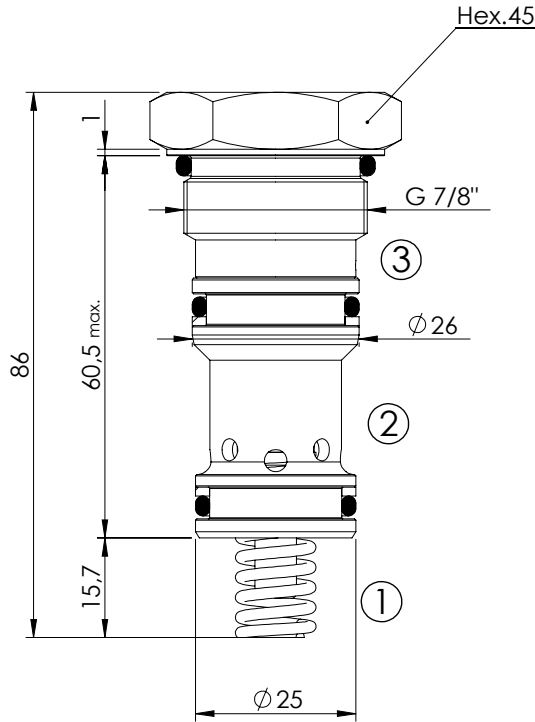

SPECIFICATIONS

Max. operating pressure:	350 bar
Rated flow:	100 l/min
Cavity:	VP000555
Weight:	0,27 kg
Spool:	$\phi 16$ mm

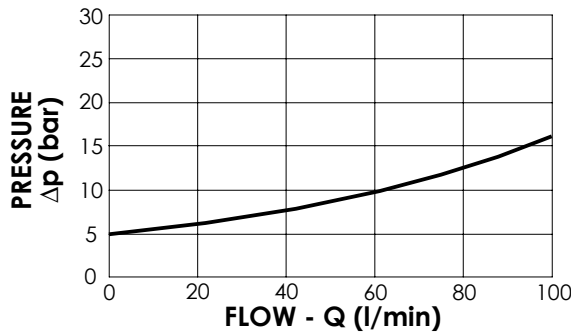

NOTES

Installation torque:	135-145 Nm
Seal kit:	RC700330
Parts in body compensator	

ORDERING CODES

Quick code	Description	Closing pressure (bar)	
CD000115	CDLN-100-SBPE-01-555-N005	5	

LOGIC ELEMENT

CDLN-200-SBPE

NORMALLY OPEN
SPOOL TYPE

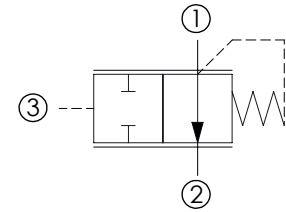
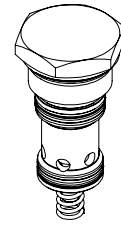
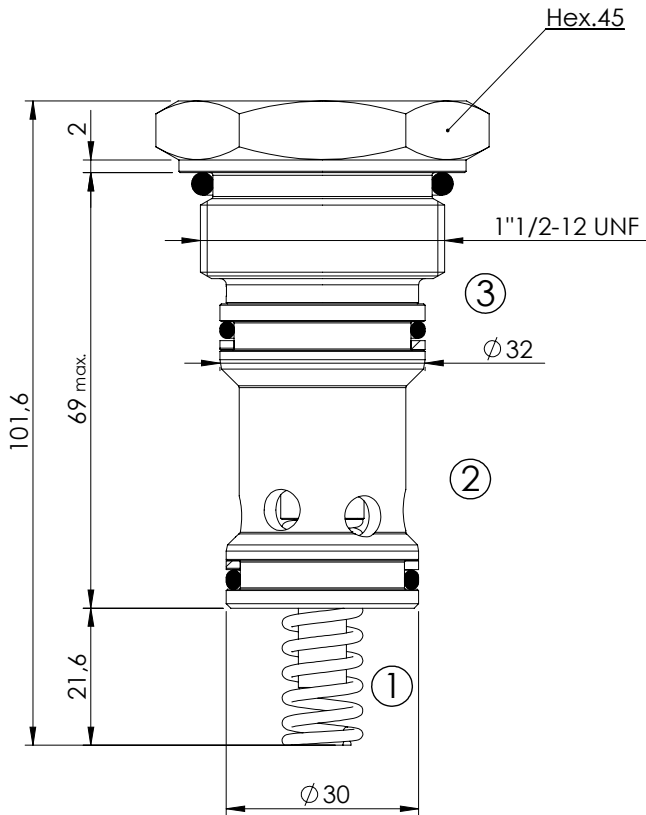

SPECIFICATIONS

Max. operating pressure:	350 bar
Rated flow:	200 l/min
Cavity:	VP000204
Weight:	0,50 kg
Spool:	Ø19 mm

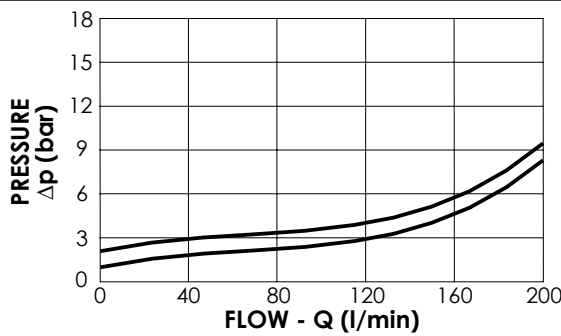

NOTES

Installation torque:	280 - 300 Nm
Seal kit:	RC700204
Parts in body compensator	

ORDERING CODES

Quick code	Description	Closing pressure (bar)	
CD000080	CDLN-200-SBPE-01-204-N001	1	
CD000286	CDLN-200-SBPE-01-204-N002	2	

LOGIC ELEMENT

CDLN-380-SBPE

NORMALLY OPEN
SPOOL TYPE

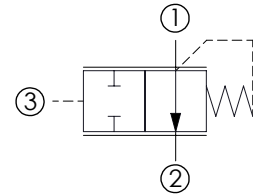
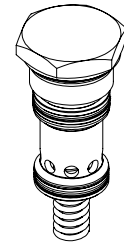
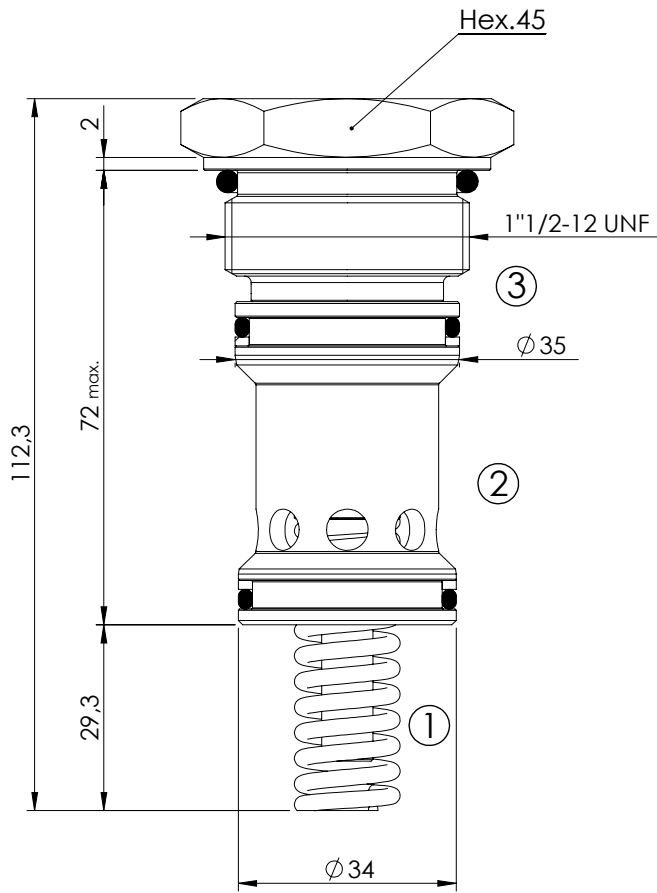

SPECIFICATIONS

Max. operating pressure:	350 bar
Rated flow:	380 l/min
Cavity:	VP000330
Weight:	0,57 kg
Spool:	Ø22 mm

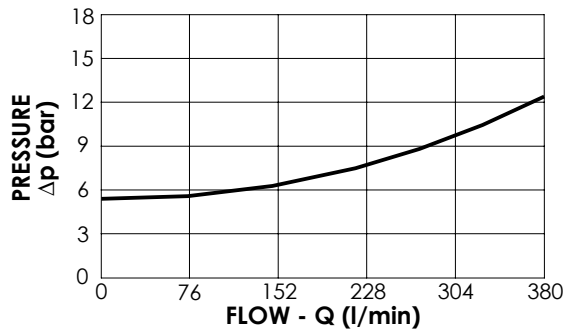

NOTES

Installation torque:	280 - 300 Nm
Seal kit:	RC700330
Parts in body compensator	

ORDERING CODES

Quick code	Description	Closing pressure (bar)	
CD000189	CDLN-380-SBPE-01-330-N005	5,5	

LOGIC ELEMENT

CDLN-160-SCTS

NORMALLY CLOSED
SPOOL TYPE
KICK DOWN TYPE

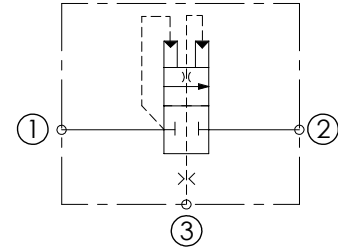
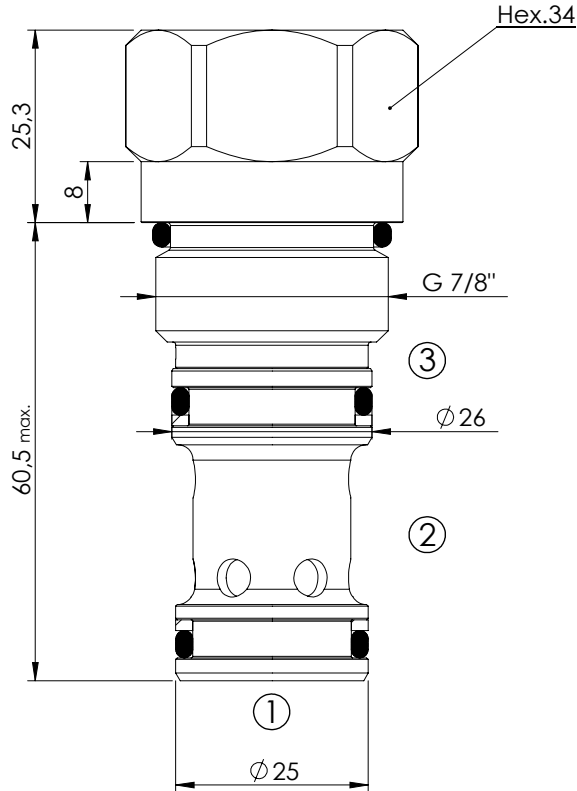
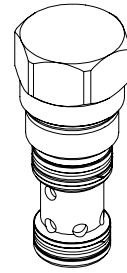

SPECIFICATIONS

Max. operating pressure:	350 bar
Rated flow:	160 l/min
Cavity:	VP000065
Weight:	0,33 kg
Spool:	Ø16 mm

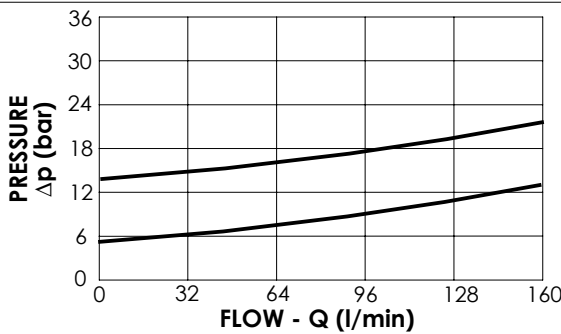

NOTES

Installation torque:	135 - 145 Nm
Seal kit:	RC900065
Parts in body compensator	

ORDERING CODES

Quick code	Description	Cracking pressure (bar)	
CD000298	CDLN-160-SCTS-01-065-N005	5	
CD000299	CDLN-160-SCTS-01-065-N014	14	



ATLANTIC
Fluid Tech

SECTION 12

Flow Dividers
and
Combiners



1800-OILSOL
1800-645765

<https://oilsolutions.com.au/>

sales@oilsolutions.com.au

SECTION 12

FLOW DIVIDERS AND COMBINERS



Hydraulic scheme	Valve description	Valve type	Rated flow (l/min)	Max. pressure (bar)	Installation	Main port size or cavity type	Page
	CFDT-055-BFAR	Spool type, divider and combiner	55	350	Cartridge	SAE-10-4N	12.01.010
	CFDT-160-BFRR	Spool type, divider and combiner	160	350	Cartridge	SAE-16-4N	12.01.020
	MFDT-040-BFTR	Spool type, divider and combiner	40	210	In line	G 3/8"	12.02.030
	MFDT-040-BFTR	Spool type, divider and combiner	40	210	In line	G 1/2"	12.02.030
	MFDT-150-BFLR	Spool type, divider and combiner	150	210	In line	G 1"	12.02.040
	MFDT-150-BFLR	Spool type, divider and combiner	150	210	In line	G 3/4"	12.02.040
	KFDT-055-BFAR	Spool type, divider and combiner	55	210	In line	G 1/4"	12.02.050
	KFDT-055-BFAR	Spool type, divider and combiner	40	210	In line	G 3/8"	12.02.050
	KFDT-055-BFAR	Spool type, divider and combiner	55	210	In line	G 1/2"	12.02.050

FLOW DIVIDER AND COMBINER

CFDT-055-BFRR

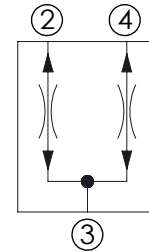
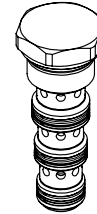
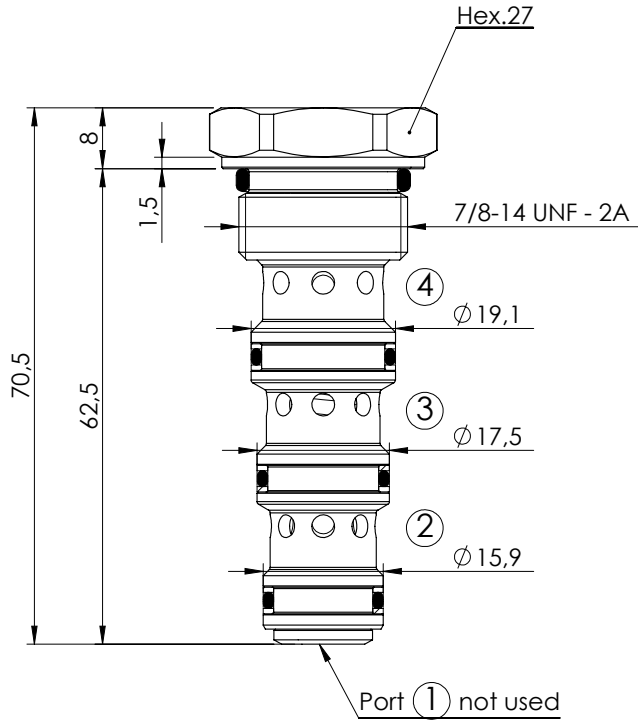

SPECIFICATIONS

Max. operating pressure:	350 bar
Division or combination:	50%-50%
Cavity:	SAE-10-4N -3P
Weight:	0,13 kg
Installation torque:	55 - 62 Nm

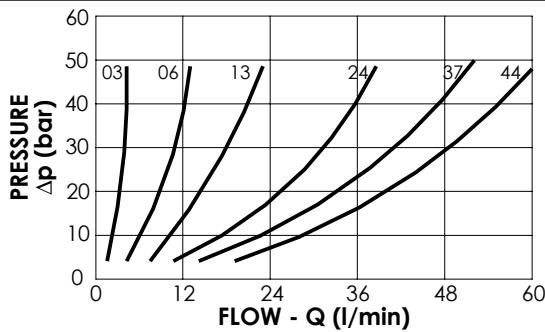

NOTES

Seal kit: **RB700102**

Flow divider accuracy: $\pm 7/8\%$ between 40-100% of max. input flow

- Other dividing ratios available.

ORDERING CODES

Quick code	Description	Inlet range Flow (l/min)	
CF000047	CFDT-055-BFRR-03-S10-N350	1,2-3	
CF000048	CFDT-055-BFRR-06-S10-N350	3-6	
CF000049	CFDT-055-BFRR-13-S10-N350	6-13	
CF000050	CFDT-055-BFRR-24-S10-N350	10-24	
CF000001	CFDT-055-BFRR-37-S10-N350	15-37	
CF000051	CFDT-055-BFRR-44-S10-N350	18-44	

FLOW DIVIDER AND COMBINER

CFDT-160-BFRR

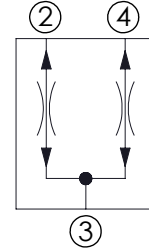
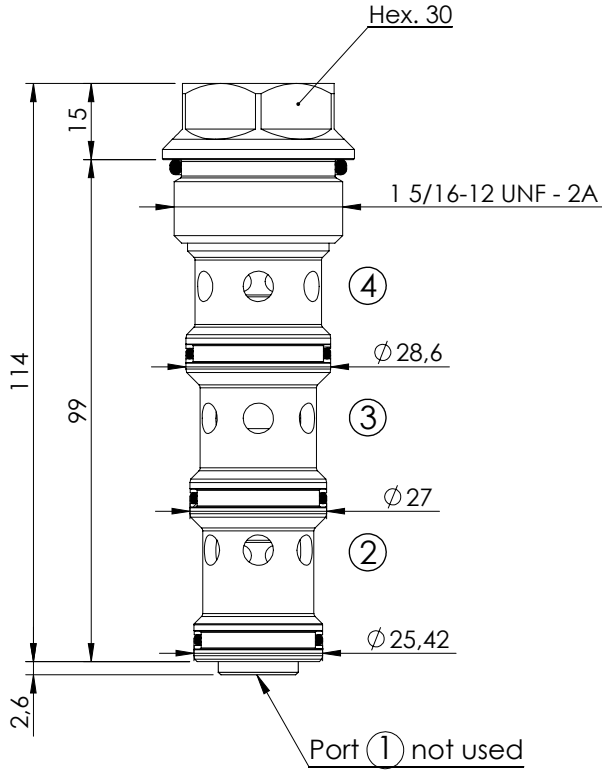

SPECIFICATIONS

Max. operating pressure:	350 bar
Division or combination:	50%-50%
Cavity:	SAE-16-4N
Weight:	0,36 kg
Installation torque:	118 - 132 Nm

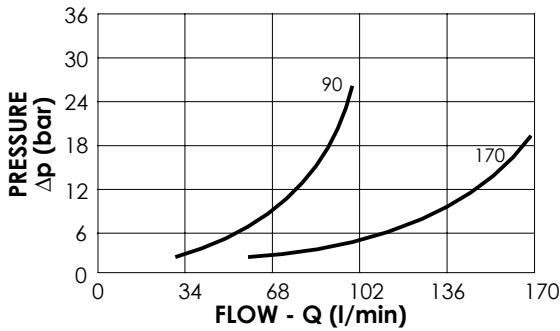

NOTES

Seal kit: RB700104

Flow divider accuracy: $\pm 7/8\%$ between 40-100% of max. input flow

- Other dividing ratios available.

ORDERING CODES

Quick code	Description	Inlet range Flow (l/min)	
CF000364	CFDT-160-BFRR-90-S16-N350	30 - 90	
CF000370	CFDT-160-BFRR-170-S16-N350	50 - 170	

FLOW DIVIDER AND COMBINER

MFDT-040-BFTR

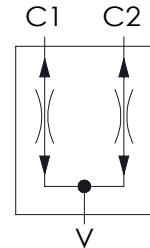
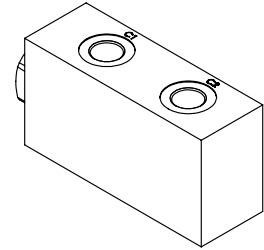
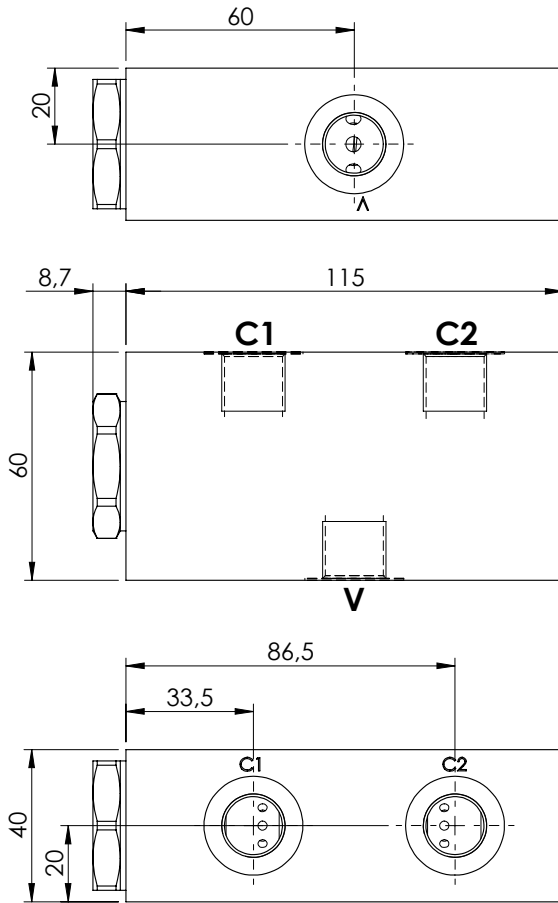

SPECIFICATIONS

Max. operating pressure:	210 bar
Division or combination:	50% - 50%
Manifold:	Aluminium
Weight:	0,88 kg
Cavity:	VP000242

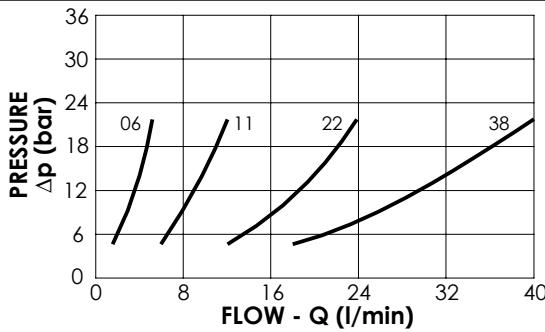

NOTES

Flow divider accuracy: ± 4/5% between 40-100% of max. input flow

ORDERING CODES

Quick code	Description	Main ports size	Inlet range Flow (l/min)	
MF000076	MFDT-040-BFTR-06-G38-N210	V:G3/8" ; C1,C2:G 3/8"	2,8 - 5,8	
MF000077	MFDT-040-BFTR-11-G38-N210	V:G3/8" ; C1,C2:G 3/8"	6,5 - 11	
MF000078	MFDT-040-BFTR-22-G38-N210	V:G3/8" ; C1,C2:G 3/8"	13 - 22	
MF000075	MFDT-040-BFTR-38-G38-N210	V:G3/8" ; C1,C2:G 3/8"	25 - 38	
MF000080	MFDT-040-BFTR-06-G12-N210	V:G1/2" ; C1,C2:G 3/8"	2,8 - 5,8	
MF000081	MFDT-040-BFTR-11-G12-N210	V:G1/2" ; C1,C2:G 3/8"	6,5 - 11	
MF000082	MFDT-040-BFTR-22-G12-N210	V:G1/2" ; C1,C2:G 3/8"	13 - 22	
MF000079	MFDT-040-BFTR-38-G12-N210	V:G1/2" ; C1,C2:G 3/8"	25 - 38	

FLOW DIVIDER AND COMBINER

MFDT-150-BFLR

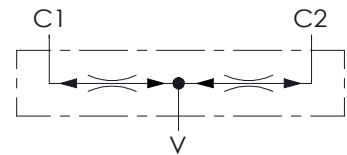
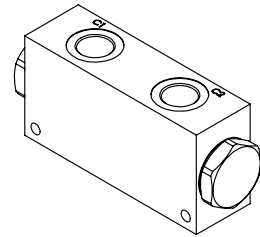
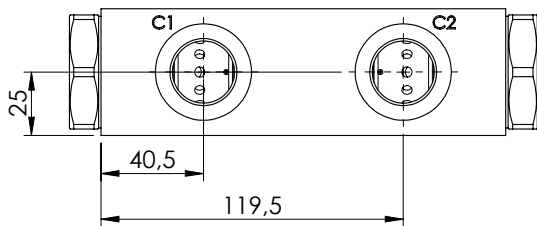
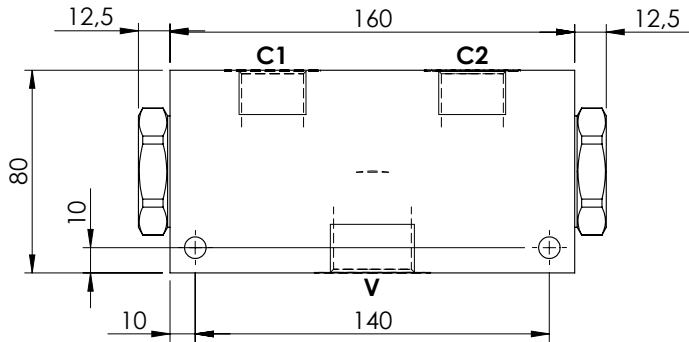
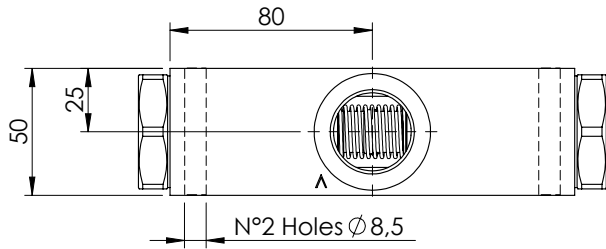

SPECIFICATIONS

Max. operating pressure:	210 bar
Division or combination:	50% - 50%
Manifold:	Aluminium
Weight:	2,1 kg

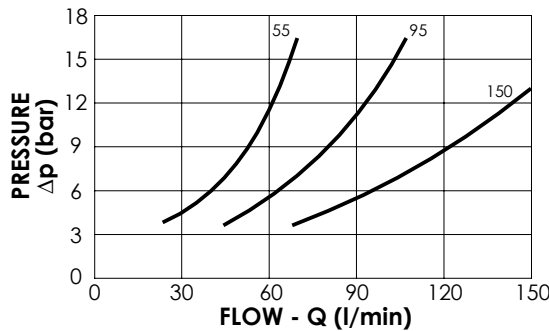

NOTES

Flow divider accuracy: ± 4-5% between 40-100% of max. input flow

ORDERING CODES

Quick code	Description	Main ports size	Inlet range Flow (l/min)	
MF000117	MFDT-150-BFLR-95-G10-N210	V: G 1" C1,C2: G 3/4"	56 - 95	
MF000118	MFDT-150-BFLR-15-G10-N210	V: G 1" C1,C2: G 3/4"	90 - 150	
MF000122	MFDT-150-BFLR-55-G34-N210	V: G 3/4" C1,C2: G 1/2"	28 - 55	
MF000123	MFDT-150-BFLR-95-G34-N210	V: G 3/4" C1,C2: G 1/2"	56 - 95	

FLOW DIVIDER AND COMBINER

KFDT-055-BFAR

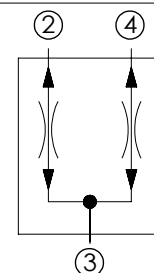
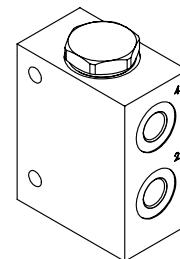
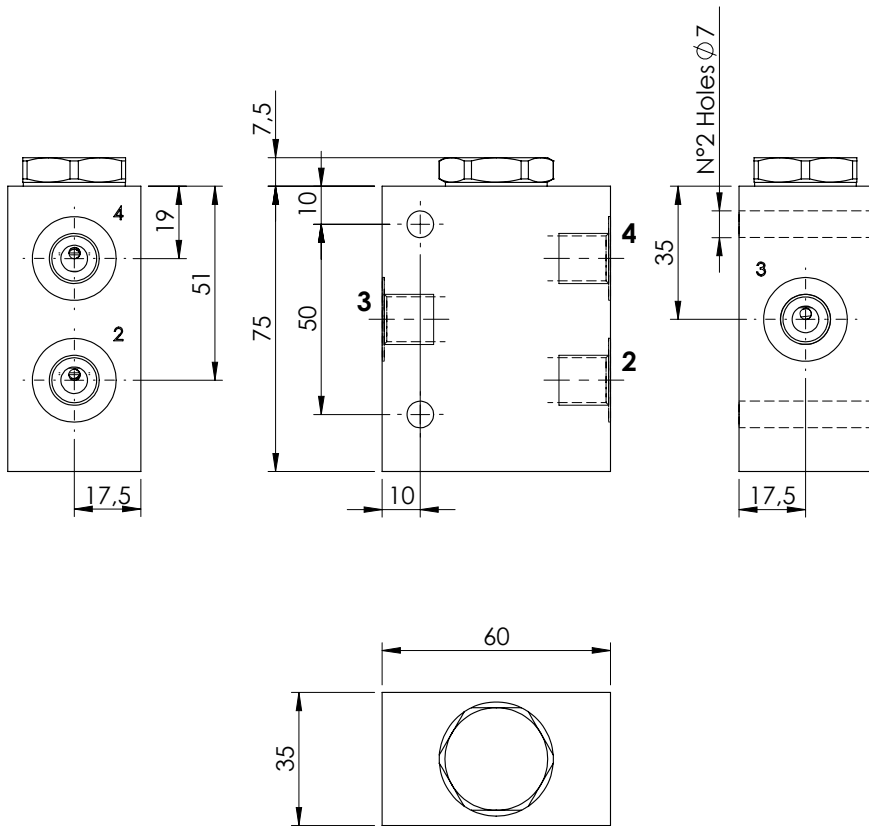

SPECIFICATIONS

Max. operating pressure:	210 bar
Division or combination:	50%-50%
Manifold:	Aluminium
Weight:	0,46 kg
Size:	SAE-10-4N

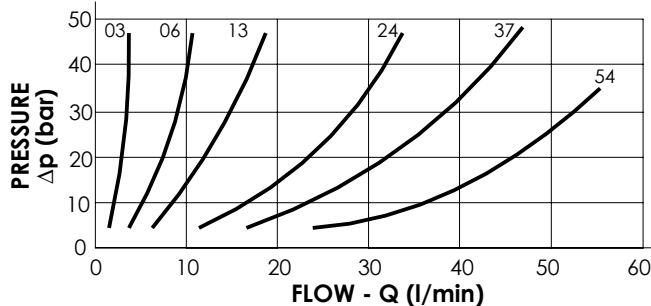

NOTES

Flow divider accuracy: $\pm 7/8\%$ between 40-100% of max. input flow

ORDERING CODES

Quick code	Description	Main ports size	Inlet range Flow (l/min)
KF000005	KFDT-055-BFAR-03-G14-N210-L	2,3,4 : G 1/4"	1.2-3
KF000006	KFDT-055-BFAR-06-G14-N210-L	2,3,4 : G 1/4"	3-6
KF000007	KFDT-055-BFAR-13-G14-N210-L	2,3,4 : G 1/4"	6-13
KF000010	KFDT-055-BFAR-13-G38-N210-L	2,3,4 : G 3/8"	6-13
KF000011	KFDT-055-BFAR-24-G38-N210-L	2,3,4 : G 3/8"	10-24
KF000012	KFDT-055-BFAR-37-G38-N210-L	2,3,4 : G 3/8"	15-37
KF000009	KFDT-055-BFAR-37-G12-N210-L	2,3,4 : G 1/2"	15-37
KF000008	KFDT-055-BFAR-44-G12-N210-L	2,3,4 : G 1/2"	18-44
KF000004	KFDT-055-BFAR-54-G12-N210-L	2,3,4 : G 1/2"	22-54



ATLANTIC
Fluid Tech

SECTION 13

Flow Control
Valves



1800-OILSOL
1800-645765

<https://oilsolutions.com.au/>

sales@oilsolutions.com.au

SECTION 13



FLOW CONTROL VALVES

Hydraulic scheme	Valve description	Valve type	Rated flow (l/min)	Max. pressure (bar)	Installation	Main port size or cavity type	Page
	CFFN-015-MFSR	Disk type, double mounting	15	350	Insert	G 1/4"	13.01.010
	CFFN-030-MFSR	Disk type, double mounting	30	350	Insert	G 3/8"	13.01.020
	CFFN-070-MFSR	Disk type, double mounting	70	350	Insert	G 1/2"	13.01.030
	CDFN-010-PSNC	Poppet type	10	350	Sleeve	G 1/4"	13.02.040
	CFSN-040-MHRR	Not compensated	40	350	Cartridge	SAE-08-2N	13.03.050
	CFSN-040-BHRR	Not compensated	40	350	Cartridge	SAE-08-2N	13.04.060
	CFSN-070-BHRR	Not compensated	70	350	Cartridge	SAE-10-2N	13.04.070
	CFHN-030-MHST	Hose burst valve	29	350	Insert	G 1/4"	13.05.080
	CFHN-050-MHST	Hose burst valve	45	350	Insert	G 3/8"	13.05.080
	CFHN-070-MHST	Hose burst valve	67	350	Insert	G 1/2"	13.05.080
	CFHN-170-MHST	Hose burst valve	169	350	Insert	G 3/4"	13.05.080
	CFHN-230-MHST	Hose burst valve	223	350	Insert	G 1"	13.05.080
	CFST-010-MDST	Two ways compensated	10	350	Insert	G 1/4"	13.06.090
	CFST-025-MDST	Two ways compensated	25	350	Insert	G 3/8"	13.06.090
	CFST-070-MDST	Two ways compensated	67	350	Insert	G 1/2"	13.06.090
	CFST-150-MDST	Two ways compensated	150	350	Insert	G 3/4"	13.06.090
	CFCT-060-MHRR	Three ways combination	60	350	Cartridge	SAE-10-3N	13.07.100
	CFPT-140-MVRR	Three ways combination	140	350	Cartridge	SAE-16-3N	13.08.110
	MFST-030-RVTR-30	Two ways compensated	30	210-350	In line	G 3/8"	13.09.120
	MFST-055-RVTR-55	Two ways compensated	55	210-350	In line	G 1/2"	13.09.130
	MFST-090-RPZR	Two ways compensated	90	210	In line	G 1/2"	13.09.140
	MFST-090-RVTR-90	Two ways compensated	90	210-350	In line	G 3/4"	13.09.150
	MFST-190-RVTR-19	Two ways compensated	190	210-350	In line	G 1"	13.09.160
	MFST-055-VVTR	Two ways compensated with check valve	55	210	In line	G 1/2"	13.10.170
	MFCT-055-RVTR-30	Three ways compensated	55	210-350	In line	G 3/8"	13.11.180
	MFCT-090-RVTR-55	Three ways compensated	90	210-350	In line	G 1/2"	13.11.190
	MFCT-090-RPZR	Three ways compensated	90	210	In line	G 1/2"	13.11.200
	MFCT-150-RVTR-90	Three ways compensated	150	210-350	In line	G 3/4"	13.11.210
	MFCT-280-RVTR-19	Three ways compensated	280	210-350	In line	G 1"	13.11.220
	MFPT-090-RVTR	Pressure compensated, priority flow regulator	90	210	In line	G 1/2"	13.11.230
	MFPT-090-RPZR	Pressure compensated, priority flow regulator	90	210	In line	G 1/2"	13.11.240

SECTION 13



FLOW CONTROL VALVES

Hydraulic scheme	Valve description	Valve type	Rated flow (l/min)	Max. pressure (bar)	Installation	Main port size or cavity type	Page
	MFCT-090-RVTN	Three ways compensated	90	210	In line	G 1/2"	13.11.250
	MFCT-090-VPZR	Three ways compensated with check valve	90	210	In line	G 1/2"	13.12.260
	MFCT-090-LPZR	Three ways compensated with relief valve	90	210	In line	G 1/2"	13.13.270
	MFCT-090-TPZR	Three ways compensated by pass check valve	90	210	In line	G 1/2"	13.14.280
	MFCT-090-MPTR	Three ways with relief valve and electric unloading	90	210	In line	G 1/2"	13.15.290
	MFCT-280-MVTR	Three ways with relief valve and electric unloading	280	210	In line	G 1"	13.16.300
	BPNN-025-LLEU	Solenoid operated valves	25	350	In line	G 1/2"	13.17.310
	MFCT-150-LHTR	Three ways compensated with relief valve	150	210	In line	G 1"	13.18.320
	MFPT-100-RHAR	Pressure compensated, priority flow regulator	100	350	In line	G 1/2"	13.19.330
	MFPT-200-RHAR	Pressure compensated, priority flow regulator	200	350	In line	G 3/4"	13.20.340
	MFPT-300-RHAR	Pressure compensated, priority flow regulator	300	350	In line	G 1"	13.20.350
	MFPT-100-MHAR	Pressure compensated, priority flow regulator	100	350	In line	G 1/2"	13.21.360
	MFPT-200-MHAR	Pressure compensated, priority flow regulator	200	350	In line	G 3/4"	13.21.370
	MFPT-300-MHAR	Pressure compensated, priority flow regulator	300	350	In line	G 1"	13.21.380
	MFPT-400-MHAR	Pressure compensated, priority flow regulator	400	350	In line	G 1" 1/4	13.22.390

SECTION 13

FLOW CONTROL VALVES



Hydraulic scheme	Valve description	Valve type	Rated flow (l/min)	Max. pressure (bar)	Installation	Main port size or cavity type	Page
	MFTT-100-MHAR	Pressure compensated, priority flow regulator	2x100	350	In line	G 1/2"	13.23.400
	MFTT-200-MHAR	Pressure compensated, priority flow regulator	2x200	350	In line	G 3/4"	13.23.410
	MFTT-300-MHAR	Pressure compensated, priority flow regulator	2x300	350	In line	G 1"	13.23.420
	MFCZ-040-LSLR	Proportional valve, compensated	40	210	In line	G 3/8"	13.24.430
	MFCZ-030-LSLR	Proportional valve, compensated	30	210	In line	G 3/8"	13.24.430
	MFCZ-020-LSLR	Proportional valve, compensated	20	210	In line	G 3/8"	13.24.430
	MFPC-140-AMLR	Proportional valve, compensated	90	210	In line	G 1/2"	13.25.440
	MFPC-140-LMLR	Proportional valve, compensated	90	210	In line	G 1/2"	13.26.450
	MFPC-140-TMLR	Proportional valve, compensated	90	210	In line	G 1/2"	13.27.460
	MFPC-200-MMAR	Proportional valve, compensated	200	250	In line	G 3/4"	13.28.470

FLOW CONTROL VALVES

CFFN-015-MFSR

INSERT TYPE
DOUBLE MOUNTING

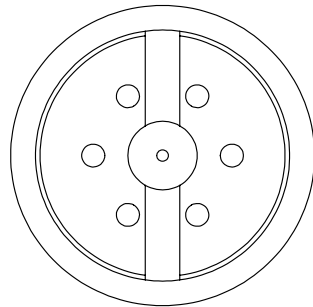
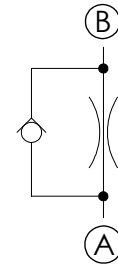
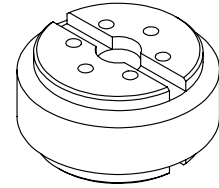
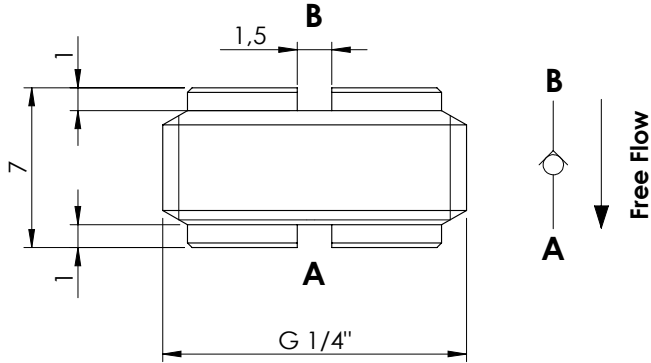

SPECIFICATIONS

Max. operating pressure:	350 bar
Rated flow:	15 l/min
Cavity:	G 1/4"
Weight:	0,01 kg
Installation torque:	5 Nm

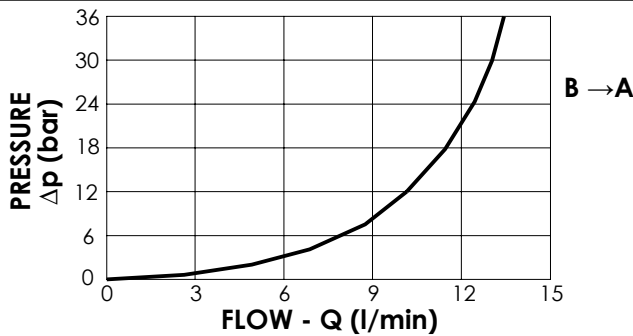

ORDERING CODES

Quick code	Description	Ø Orifice	Quick code	Description	Ø Orifice
CF000118	CFFN-015-MFSR-05-G14-N350	0,5	CF000205	CFFN-015-MFSR-13-G14-N350	1,3
CF000119	CFFN-015-MFSR-06-G14-N350	0,6	CF000206	CFFN-015-MFSR-14-G14-N350	1,4
CF000120	CFFN-015-MFSR-07-G14-N350	0,7	CF000123	CFFN-015-MFSR-15-G14-N350	1,5
CF000121	CFFN-015-MFSR-08-G14-N350	0,8	CF000207	CFFN-015-MFSR-16-G14-N350	1,6
CF000203	CFFN-015-MFSR-09-G14-N350	0,9	CF000208	CFFN-015-MFSR-17-G14-N350	1,7
CF000088	CFFN-015-MFSR-10-G14-N350	1	CF000209	CFFN-015-MFSR-18-G14-N350	1,8
CF000204	CFFN-015-MFSR-11-G14-N350	1,1	CF000210	CFFN-015-MFSR-19-G14-N350	1,9
CF000122	CFFN-015-MFSR-12-G14-N350	1,2	CF000124	CFFN-015-MFSR-20-G14-N350	2,0

FLOW CONTROL VALVES

CFFN-030-MFSR

INSERT TYPE
DOUBLE MOUNTING

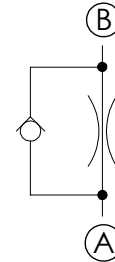
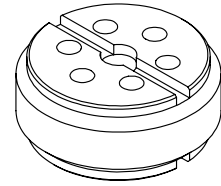
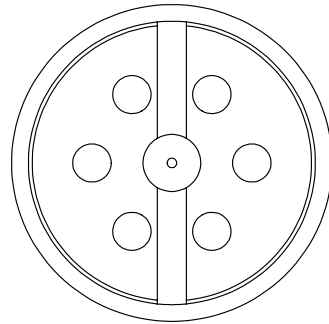
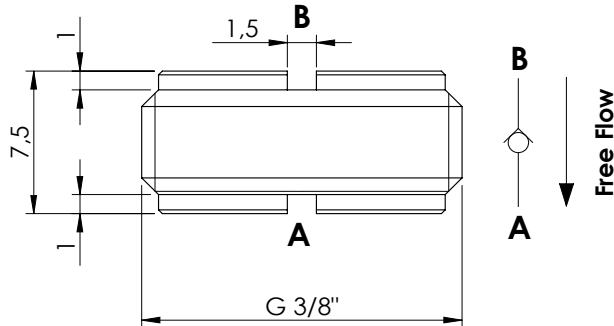

SPECIFICATIONS

Max. operating pressure:	350 bar
Rated flow:	30 l/min
Cavity:	G 3/8
Weight:	0,01 kg
Installation torque:	10 Nm

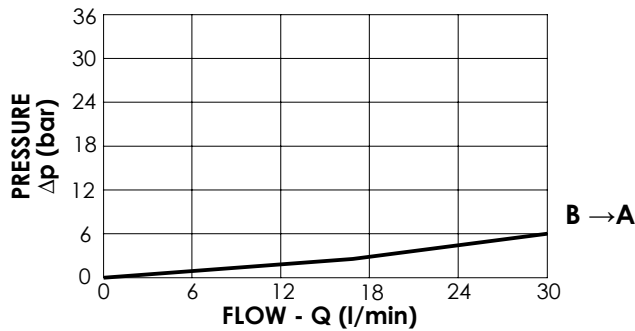

ORDERING CODES

Quick code	Description	Ø Orifice	Quick code	Description	Ø Orifice
CF000068	CFFN-030-MFSR-05-G38-N350	0,5	CF000197	CFFN-030-MFSR-13-G38-N350	1,3
CF000069	CFFN-030-MFSR-06-G38-N350	0,6	CF000198	CFFN-030-MFSR-14-G38-N350	1,4
CF000070	CFFN-030-MFSR-07-G38-N350	0,7	CF000074	CFFN-030-MFSR-15-G38-N350	1,5
CF000071	CFFN-030-MFSR-08-G38-N350	0,8	CF000199	CFFN-030-MFSR-16-G38-N350	1,6
CF000195	CFFN-030-MFSR-09-G38-N350	0,9	CF000200	CFFN-030-MFSR-17-G38-N350	1,7
CF000072	CFFN-030-MFSR-10-G38-N350	1	CF000201	CFFN-030-MFSR-18-G38-N350	1,8
CF000196	CFFN-030-MFSR-11-G38-N350	1,1	CF000202	CFFN-030-MFSR-19-G38-N350	1,9
CF000073	CFFN-030-MFSR-12-G38-N350	1,2	CF000125	CFFN-030-MFSR-20-G38-N350	2,0

FLOW CONTROL VALVES

CFFN-070-MFSR

INSERT TYPE
DOUBLE MOUNTING

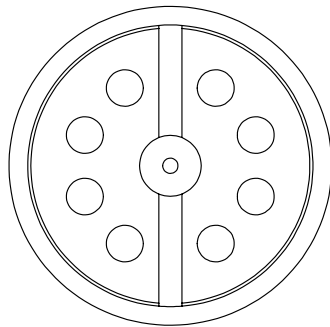
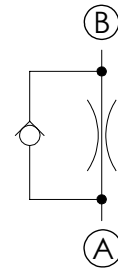
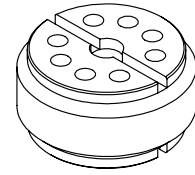
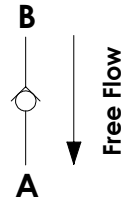
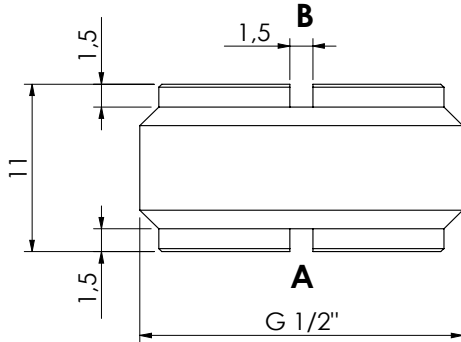

SPECIFICATIONS

Max. operating pressure:	350bar
Rated flow:	70 l/min
Cavity:	G 1/2
Weight:	0,02 kg
Installation torque:	10 Nm

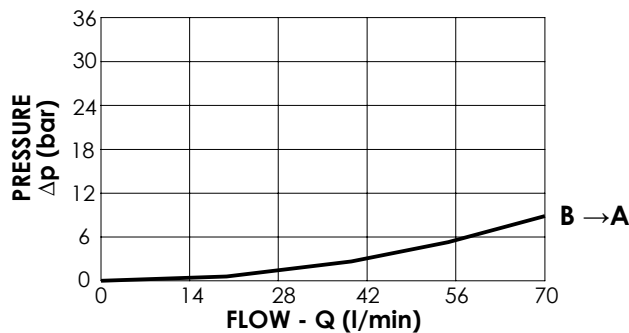

ORDERING CODES

Quick code	Description	Ø Orifice	Quick code	Description	Ø Orifice
CF000127	CFFN-070-MFSR-10-G12-N350	1,0	CF000080	CFFN-070-MFSR-33-G12-N350	3,3
CF000128	CFFN-070-MFSR-15-G12-N350	1,5			
CF000352	CFFN-070-MFSR-18-G12-N350	1,8			
CF000117	CFFN-070-MFSR-20-G12-N350	2,0			
CF000129	CFFN-070-MFSR-25-G12-N350	2,5			
CF000130	CFFN-070-MFSR-30-G12-N350	3,0			

FLOW RESTRICTOR

CDFN-010-PSNC

**MONO DIRECTIONAL
NOT COMPENSATED**

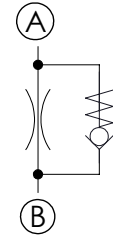
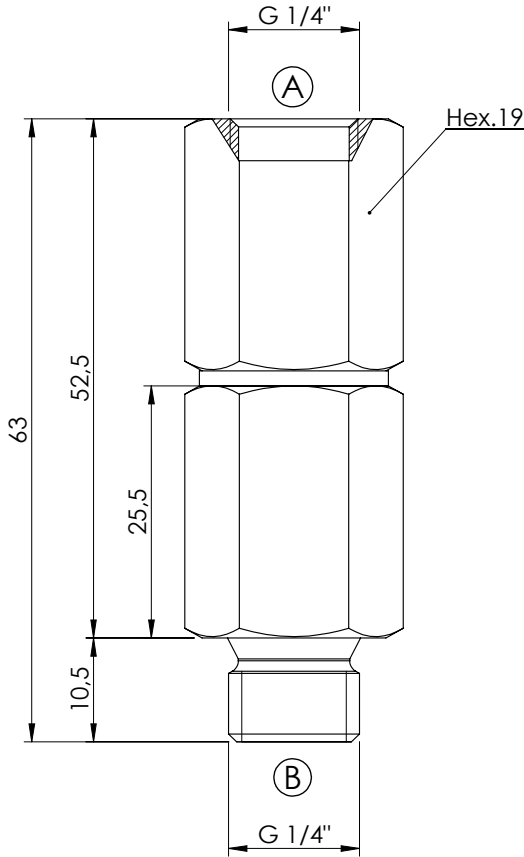

SPECIFICATIONS

Max. operating pressure:	350 bar
Rated flow (A to B):	10 l/min
Material:	Steel
Weight:	0,11 kg

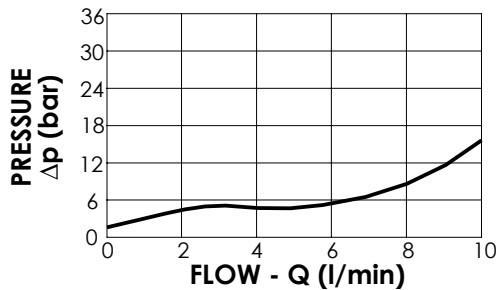

ORDERING CODES

Quick code	Description	Cracking pressure (bar)	Ports	Ø Hole (mm)
CD000084	CDFN-010-PSNC-05-G14-N350	5	A,B: G 1/4"	Ø 0,5
CD000085	CDFN-010-PSNC-06-G14-N350	5	A,B: G 1/4"	Ø 0,6
CD000086	CDFN-010-PSNC-07-G14-N350	5	A,B: G 1/4"	Ø 0,7
CD000087	CDFN-010-PSNC-08-G14-N350	5	A,B: G 1/4"	Ø 0,8
CD000089	CDFN-010-PSNC-10-G14-N350	5	A,B: G 1/4"	Ø 1
CD000091	CDFN-010-PSNC-13-G14-N350	5	A,B: G 1/4"	Ø 1,3
CD000167	CDFN-010-PSNC-03-G14-N350	5	A,B: G 1/4"	Ø 0,5 & wire Ø 0,4
CD000168	CDFN-010-PSNC-04-G14-N350	5	A,B: G 1/4"	Ø 0,6 & wire Ø 0,4

FLOW RESTRICTOR

CFSN-040-MHRR

**NEEDLE RESTRICTOR
FREE REVERSE FLOW**

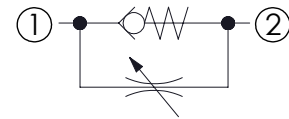
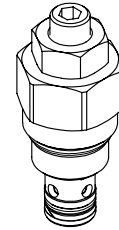
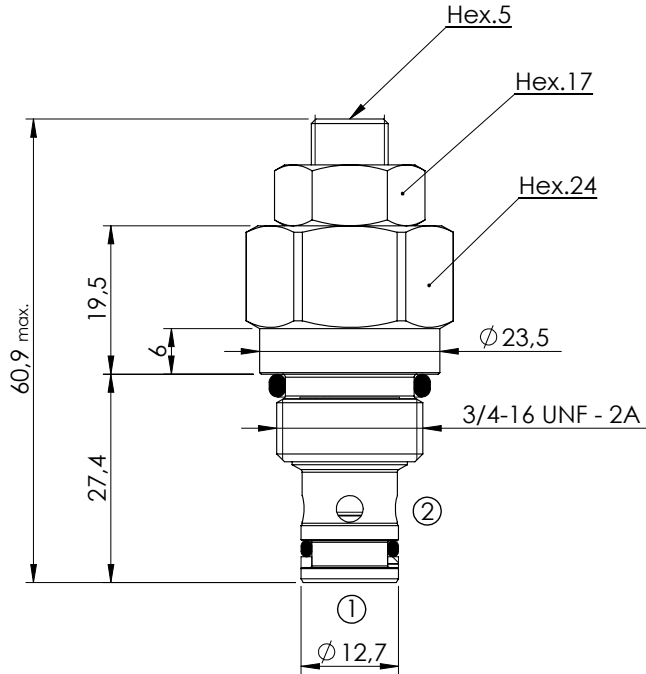

SPECIFICATIONS

Max. operating pressure:	350 bar
Rated Flow:	40 l/min
Material:	Steel
Cavity:	SAE-08-2N
Weight:	0,12 kg
Seal kit:	RA700081

NOTES

Installation torque: 45-50 Nm

ADJUSTMENT OPTIONS

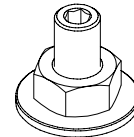

**Adjustment
with Screw**

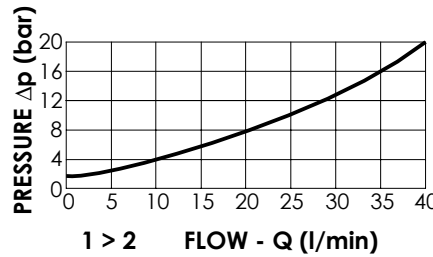
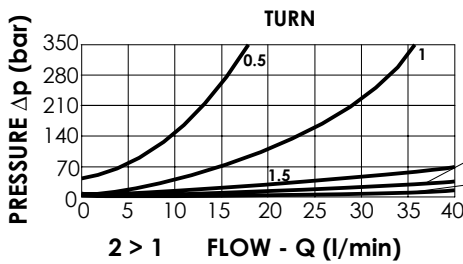

ORDERING CODES

Quick code	Description	Options
CF000167	CFSN-040-MHRR-NP-S08-N350	Adjustment with Screw

FLOW RESTRICTOR

CFSN-040-BHRR

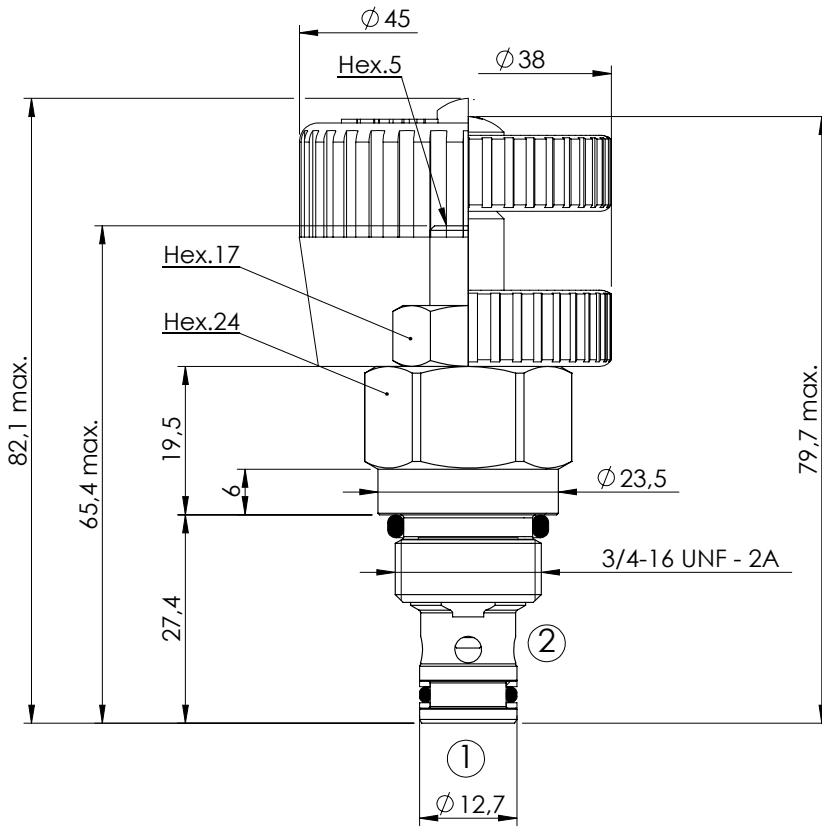
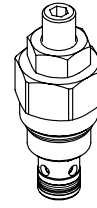

SPECIFICATIONS

Max. operating pressure:	350 bar
Rated flow:	40 l/min
Material:	Steel
Cavity:	SAE-08-2N
Weight:	0,12 kg
Seal kit:	RB700081

NOTES

Installation torque: 45-50 Nm

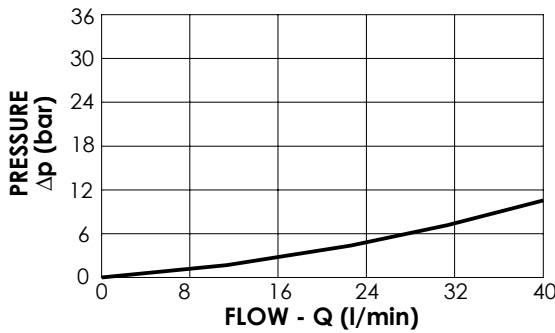

Fully open
Both directions

ADJUSTMENT OPTIONS

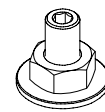

Screw and locknut



Handknob and locknut

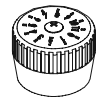

Graduated handknob

ORDERING CODES

Quick code	Description	Adjustment options
CF000112	CFSN-040-BHRR-NP-S08-N350	Screw and locknut
CF000109	CFSN-040-BVRR-NP-S08-N350	Handknob and locknut
CF000253	CFSN-040-BMRR-NP-S08-N350	Graduated handknob

FLOW RESTRICTOR

CFSN-070-BHRR

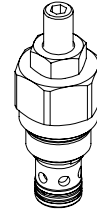
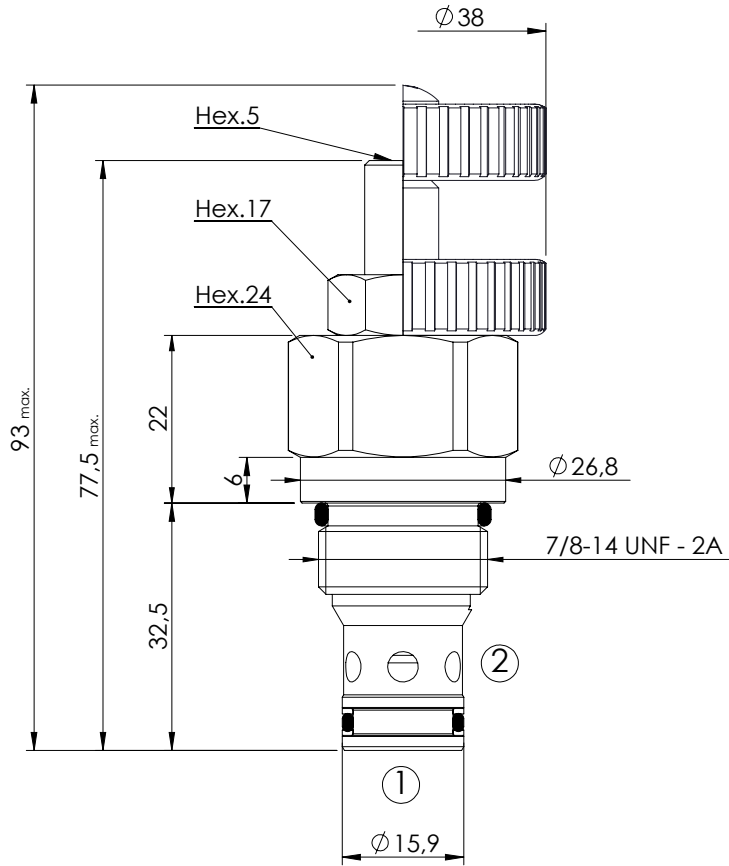

SPECIFICATIONS

Max. operating pressure:	350 bar
Rated flow:	70 l/min
Material:	Steel
Cavity:	SAE-10-2N
Weight:	0,17 kg
Seal kit:	RB700082

NOTES

Installation torque: 55-62 Nm

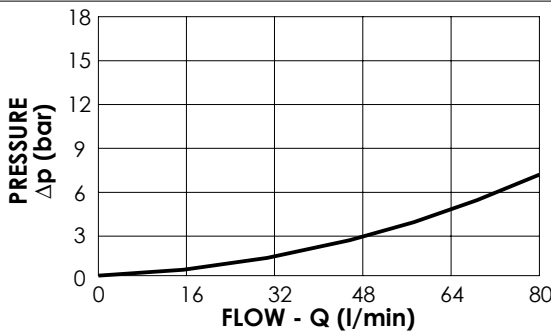

ADJUSTMENT OPTIONS

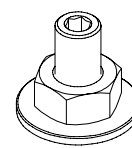

Adjustments with Screw

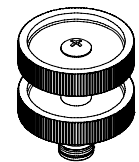

Adjustments with Handknob

ORDERING CODES

Quick code	Description	Options
CF000136	CFSN-070-BHRR-NP-S10-N350	Adjustments with Screw
CF000116	CFSN-070-BVRR-NP-S10-N350	Adjustments with Handknob

HOSE BURST VALVE

CFHN-XXX-MHST

INSERT TYPE

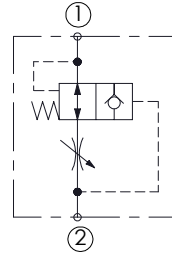
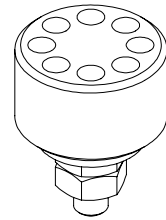
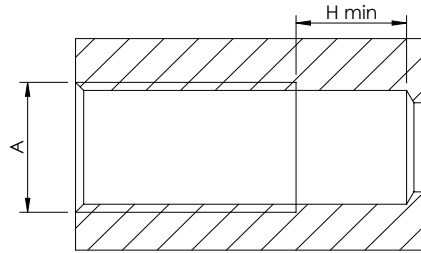
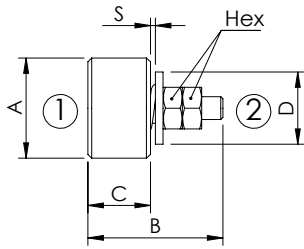

SPECIFICATIONS

Max. operating pressure: 300 bar

	Max flow (l/min)	Min flow (l/min)
G1/4"	25	4
G3/8"	50	6,3
G1/2"	80	16
G3/4"	160	25
G1"	200	80

For sleeve housing consult Accessories section

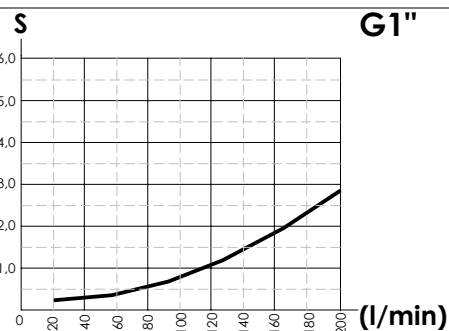
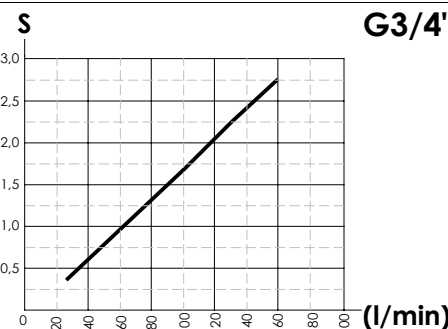
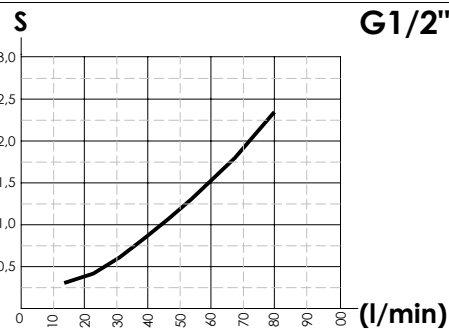
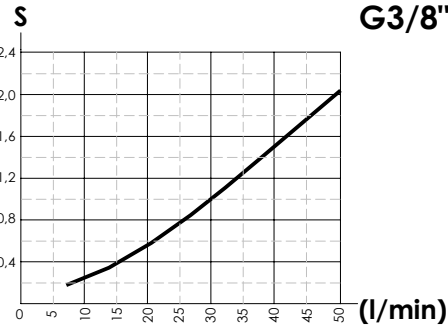
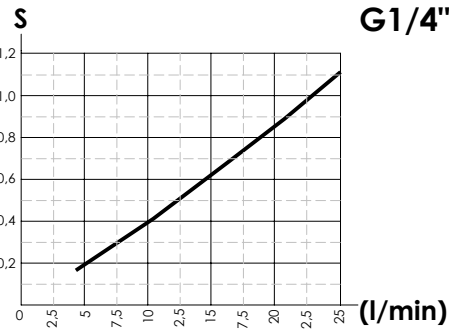

ORDERING CODES

Quick code	Description	A	B	C	D	Hex.	H
CF000348	CFHN-030-MHST-00-235	G 1/4"	17,5	8,1	9,5	5,5	11
CF000381	CFHN-050-MHST-00-234	G 3/8"	21	10,6	12,5	5,5	11
CF000379	CFHN-080-MHST-00-233	G 1/2"	25	12,1	15	7	15
CF000339	CFHN-160-MHST-00-195	G 3/4"	30,5	17,1	17,5	7	16
CF000382	CFHN-200-MHST-00-232	G 1"	38	22,1	26	7	20

FLOW REGULATOR

CFST-XXX-MDST

**2 WAYS COMPENSATED
INSERT TYPE**

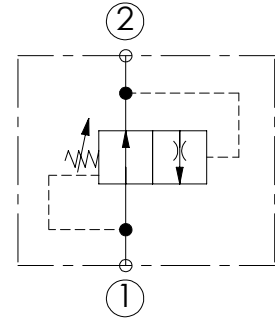
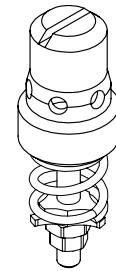
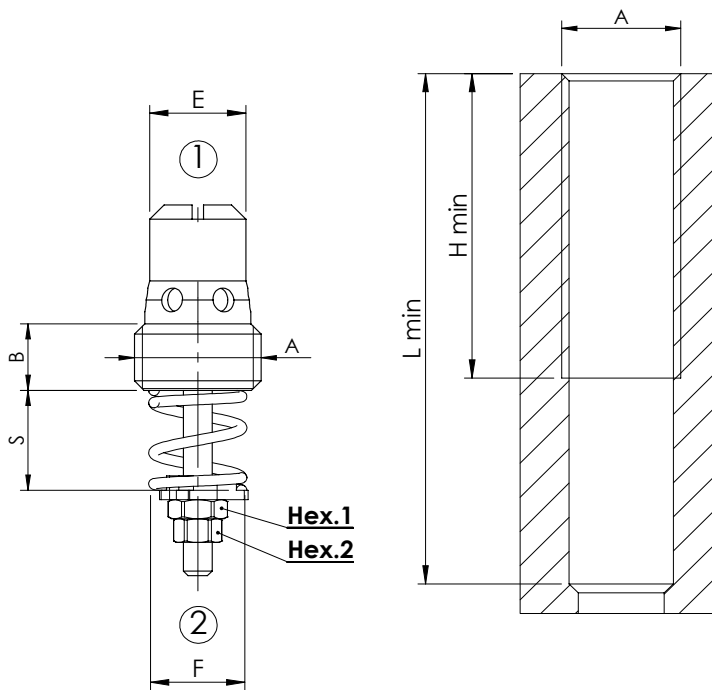

SPECIFICATIONS

Max. operating pressure: 300 bar

A	B	C	D	E	F	H min	L min	Hex.1	Hex.2	Installation torque:		Max. Flow ② → ①	Max. Flow ① → ②
G 1/4"	7	12,5	39	10	10,5	33	55	5,5	4,5	6	G1/4"	10	25
G 3/8"	7	13,5	43	11,5	13,5	34	60	7	6	8	G3/8"	25	50
G 1/2"	8	16	49	15	18	40	70	7	6	12	G1/2"	67	90
G 3/4"	10	21	61	20	23	51	80	7	6	15	G3/4"	150	150

For sleeve housing consult Accessories section

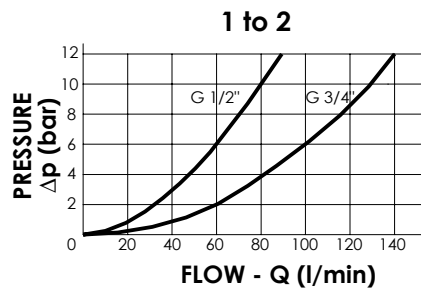
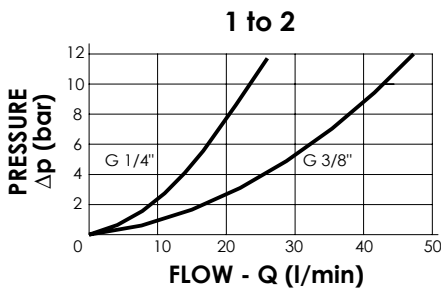

ORDERING CODES

G 1/4"		G 3/8"		G 1/2"		G 3/4"	
Quick code	Flow Range Adjustment (l/min)	Quick code	Flow Range Adjustment (l/min)	Quick code	Flow Range Adjustment (l/min)	Quick code	Flow Range Adjustment (l/min)
CF000104	1-1,6	CF000099	2,5-4	CF000093	16-21	CF000096	37-50
CF000105	1,6-2,5	CF000100	4-6,3	CF000094	21-28	CF000097	50-67
CF000106	2,5-4	CF000101	6,3-10	CF000095	28-37	CF000098	67-90
CF000107	4-6,3	CF000102	10-16	CF000081	37-50	CF000083	90-120
CF000108	6,3-10	CF000103	16-25	CF000082	50-67	CF000092	120-150

FLOW REGULATOR

CFCT-060-MHRR

**3 WAYS COMBINATION
ADJUSTABLE SETTING**

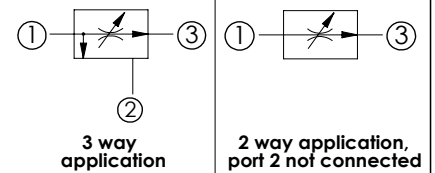
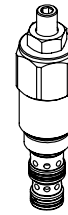
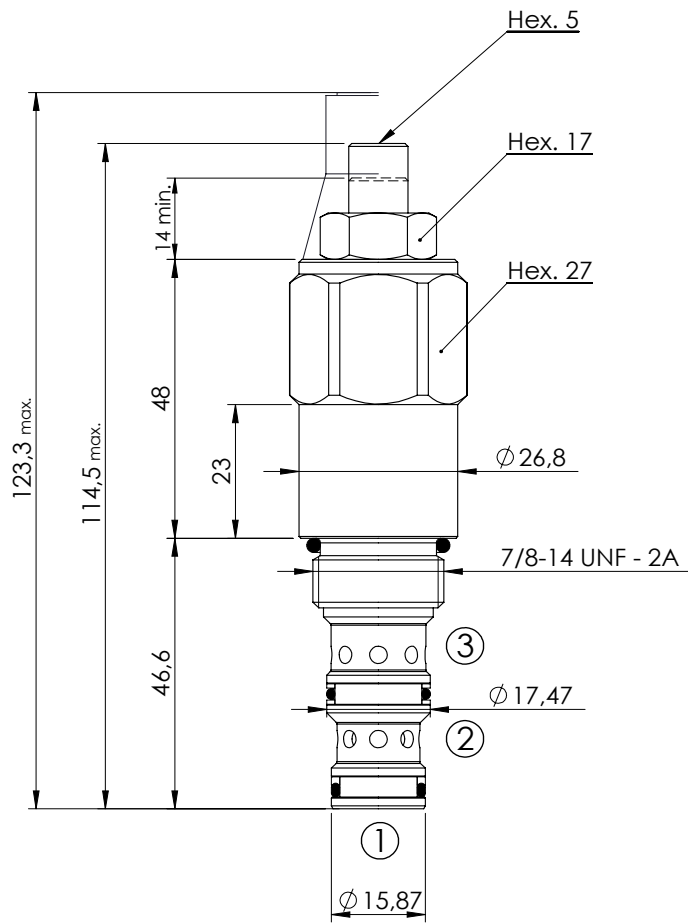

SPECIFICATIONS

Max. operating pressure:	350 bar
Rated flow:	60 l/min
Cavity:	SAE-10-3N
Weight:	0,28 kg

SEALING CAP

Ordering code:
AT000022

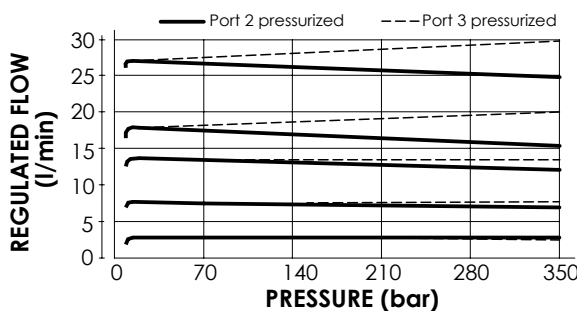
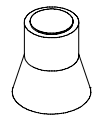

NOTES

- Installation torque: **55 - 62 Nm**
- Seal kit: **RA700092**
- If port 2 is blocked the valve operates as a two way flow regulator.
- Port 2 can be pressurized.

ORDERING CODES

Quick code	Description	Max. Inlet Flow (l/min)	Reg. Flow range (l/min)	Adjust. range (bar)
CF000063	CFCT-060-MHRR-03-S10-N350	60	2,5-3,5	Screw nut locknut
CF000149	CFCT-060-MHRR-04-S10-N350	60	3-4,5	Screw nut locknut
CF000150	CFCT-060-MHRR-06-S10-N350	60	4,2-6,2	Screw nut locknut
CF000006	CFCT-060-MHRR-09-S10-N350	60	5,8-9	Screw nut locknut
CF000054	CFCT-060-MHRR-12-S10-N350	60	8,5-12	Screw nut locknut
CF000062	CFCT-060-MHRR-16-S10-N350	60	11,5-16,5	Screw nut locknut
CF000151	CFCT-060-MHRR-23-S10-N350	60	15,5-22,5	Screw nut locknut
CF000152	CFCT-060-MHRR-30-S10-N350	60	20-29,5	Screw nut locknut
CF000057	CFCT-060-MHRR-32-S10-N350	60	26,5-35,5	Screw nut locknut

FLOW REGULATOR

CFPT-140-MVRR

**3 WAYS COMBINATION
ADJUSTABLE SETTING**

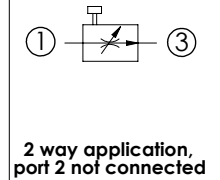
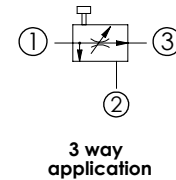
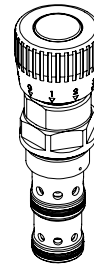
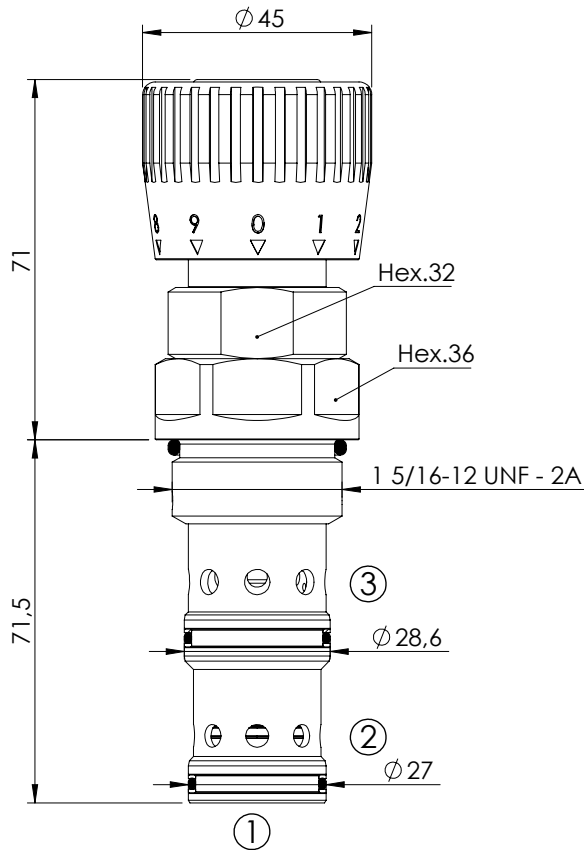

SPECIFICATIONS

Max. operating pressure:	350 bar
Division or combination:	140 l/min
Cavity:	SAE-16-3N
Weight:	0,7 kg
Seal kit:	RB700094

ADJUSTMENT TYPE

Graduated handknob for flow regulation under pressure

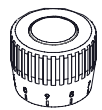

NOTES

Installation torque: 118 - 132 Nm

If port 2 is blocked the valve operates as a two way flow regulator. Port 2 can be pressurized.

The washer is used to indicate the zero.

Ordering code: SV000083

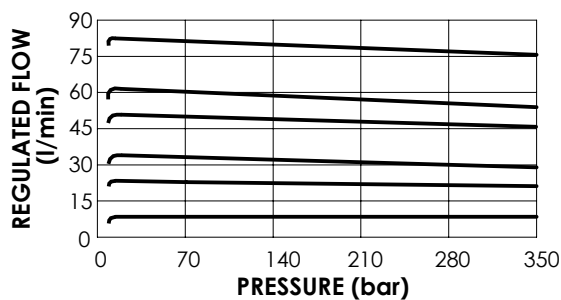
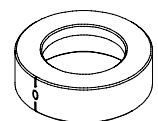

ORDERING CODES

Quick code	Description	Regulated flow range (l/min)	Adjustment option
CF000310	CFPT-140-MVRR-15-S16-N350	0 - 15	Graduated handknob
CF000311	CFPT-140-MVRR-25-S16-N350	0 - 25	Graduated handknob
CF000312	CFPT-140-MVRR-35-S16-N350	0 - 35	Graduated handknob
CF000313	CFPT-140-MVRR-50-S16-N350	0 - 50	Graduated handknob
CF000314	CFPT-140-MVRR-65-S16-N350	0 - 65	Graduated handknob
CF000315	CFPT-140-MVRR-80-S16-N350	0 - 80	Graduated handknob

FLOW REGULATOR

MFST-030-RVTR

2 WAYS COMPENSATED

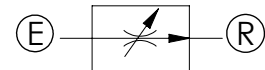
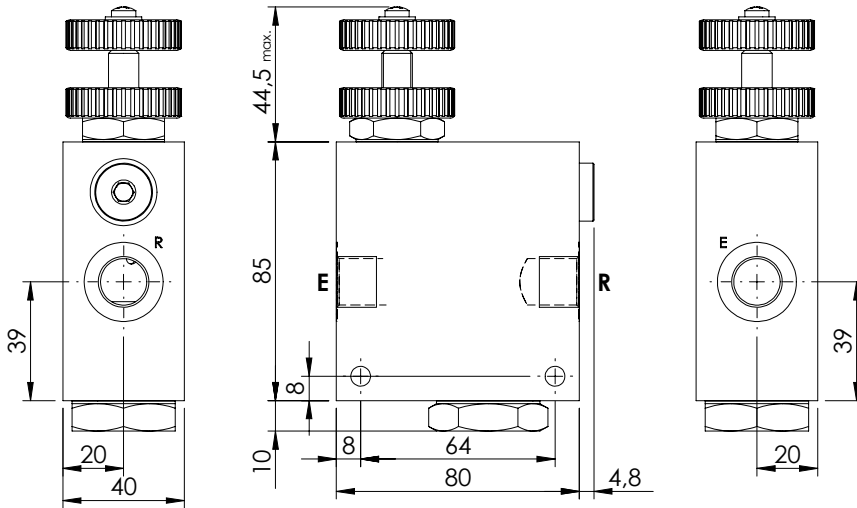
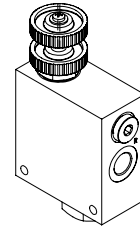

SPECIFICATIONS

Max. operating pressure:	See table
Rated flow:	30 l/min
Manifold:	Aluminium/Steel
Weight:	0,95/1,39 kg

ADJUSTMENT OPTIONS



NOTES

Regulation: FINE

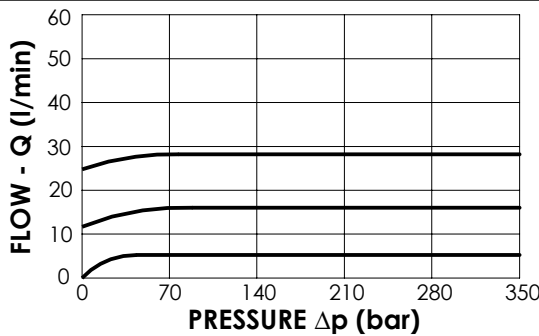

ORDERING CODES

Quick code	Description	Main ports size	Manifold	Max. Pressure (Bar)	Max. inlet flow (l/min)	Adjustment options
MF000241	MFST-030-RVTR-30-G38-N210	E,R: G 3/8"	Aluminium	210	30	Handknob and locknut
MF000242	MFST-030-RHTR-30-G38-N210	E,R: G 3/8"	Aluminium	210	30	Screw and locknut
MF000243	MFST-030-RMTR-30-G38-N210	E,R: G 3/8"	Aluminium	210	30	Graduated handknob
MF000244	MFST-030-RVSR-30-G38-N350	E,R: G 3/8"	Steel	350	30	Handknob and locknut
MF000245	MFST-030-RHSR-30-G38-N350	E,R: G 3/8"	Steel	350	30	Screw and locknut
MF000246	MFST-030-RMSR-30-G38-N350	E,R: G 3/8"	Steel	350	30	Graduated handknob

FLOW REGULATOR

MFST-055-TVTR

2 WAYS COMPENSATED

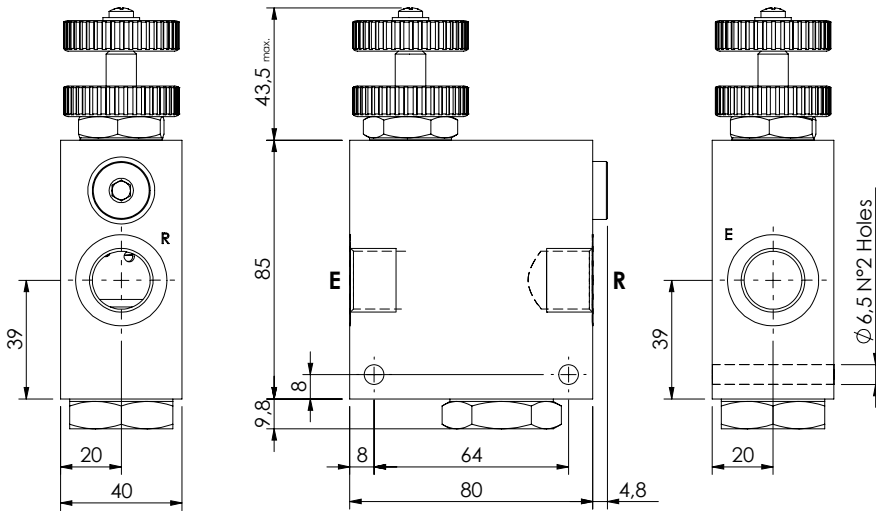
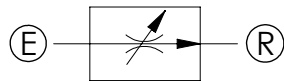
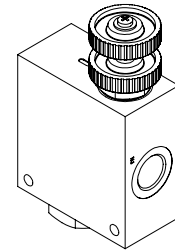

SPECIFICATIONS

Max. operating pressure:	See table
Rated flow:	55 l/min
Manifold:	Aluminium/Steel
Weight:	0,94/2,01 kg

ADJUSTMENT OPTIONS



NOTES

Regulation: FINE

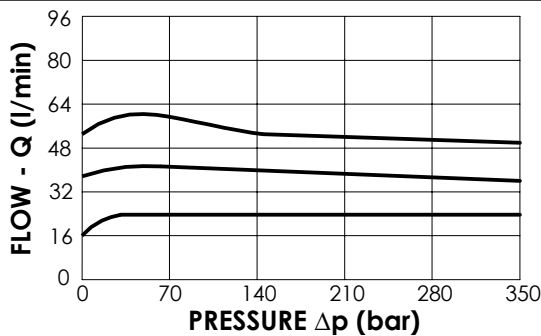

ORDERING CODES

Quick code	Description	Main ports size	Manifold	Max. Pressure (Bar)	Max. inlet flow (l/min)	Adjustment options
MF000052	MFST-055-RVTR-55-G12-N210	E,R: G 1/2"	Aluminium	210	55	Handknob and locknut
MF000238	MFST-055-RHTR-55-G12-N210	E,R: G 1/2"	Aluminium	210	55	Screw and locknut
MF000106	MFST-055-RMTR-55-G12-N210	E,R: G 1/2"	Aluminium	210	55	Graduated handknob
MF000148	MFST-055-RVSR-55-G12-N350	E,R: G 1/2"	Steel	350	55	Handknob and locknut
MF000239	MFST-055-RHSR-55-G12-N350	E,R: G 1/2"	Steel	350	55	Screw and locknut
MF000240	MFST-055-RMSR-55-G12-N350	E,R: G 1/2"	Steel	350	55	Graduated handknob

FLOW REGULATOR

MFST-090-RPZR

2 WAYS COMPENSATED

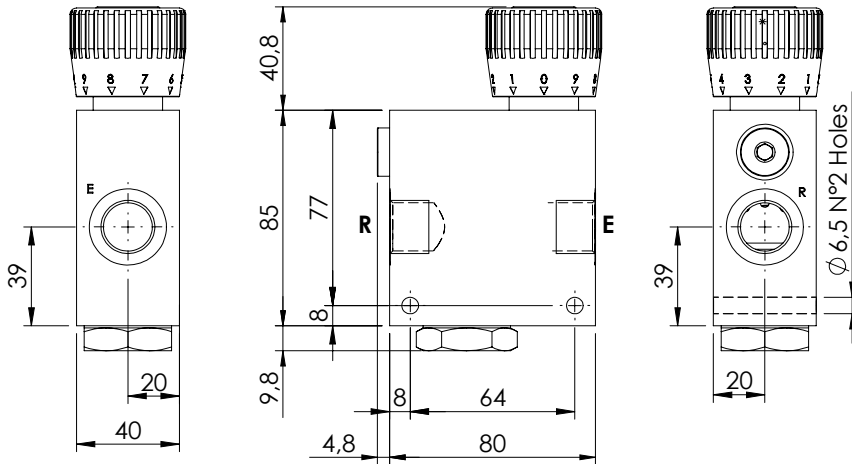
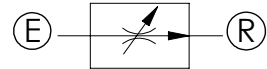
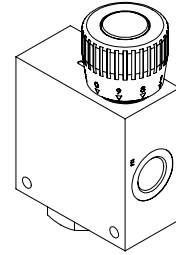
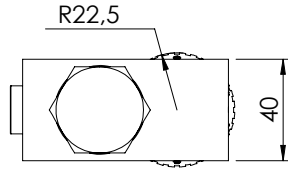

SPECIFICATIONS

Max. operating pressure:	210 bar
Rated flow:	90 l/min
Manifold:	Aluminium
Weight:	0,93 kg

ADJUSTMENT TYPE

Graduated handknob for flow regulation under pressure

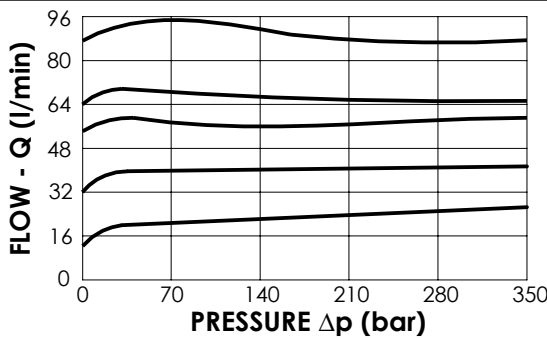
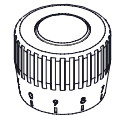

ORDERING CODES

Quick code	Description	Main ports size	Regulated flow range (l/min)	Adjustment type
MF000186	MFST-090-RPZR-06-G12-N210	G 1/2"	0 - 6	Graduated handknob
MF000187	MFST-090-RPZR-12-G12-N210	G 1/2"	0 - 12	Graduated handknob
MF000188	MFST-090-RPZR-25-G12-N210	G 1/2"	0 - 25	Graduated handknob
MF000189	MFST-090-RPZR-32-G12-N210	G 1/2"	0 - 32	Graduated handknob
MF000190	MFST-090-RPZR-50-G12-N210	G 1/2"	0 - 50	Graduated handknob
MF000191	MFST-090-RPZR-63-G12-N210	G 1/2"	0 - 63	Graduated handknob

FLOW REGULATOR

MFST-090-RVTR

2 WAYS COMPENSATED

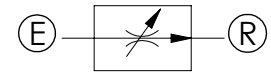
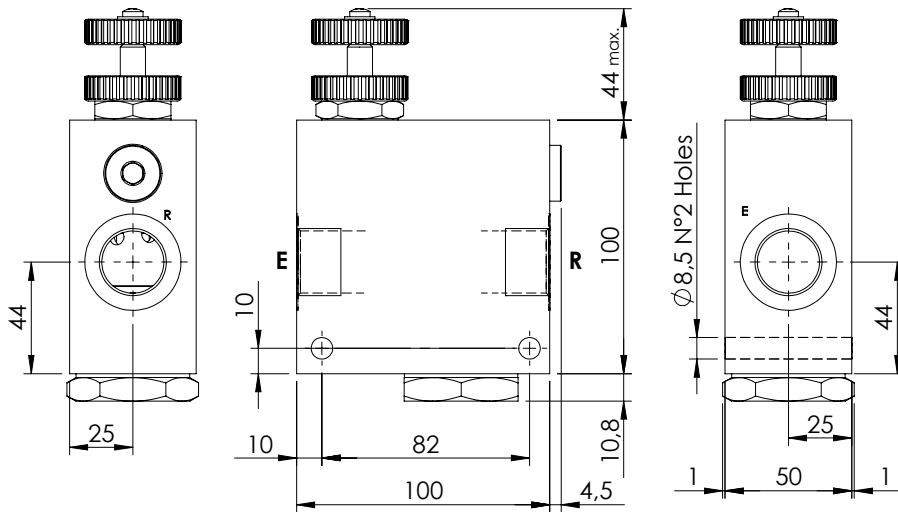
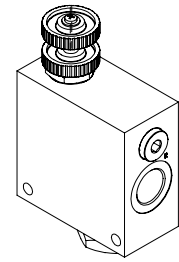

SPECIFICATIONS

Max. operating pressure:	See table
Rated flow:	90 l/min
Manifold:	Aluminium/Steel
Weight:	1,66 / 3,6 kg

ADJUSTMENT OPTIONS

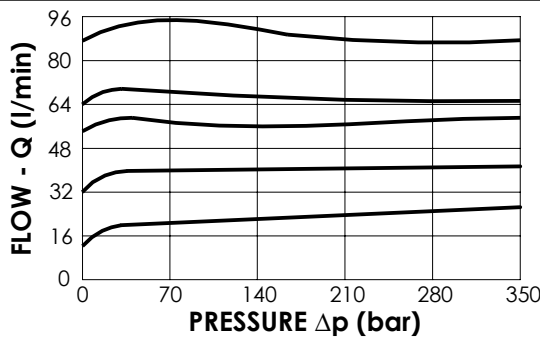

NOTES

Regulation: STANDARD

ORDERING CODES

Quick code	Description	Main ports size	Manifold	Max. pressure (Bar)	Max. inlet flow (l/min)	Adjustment options
MF000042	MFST-090-RVTR-90-G34-N210	E,R: G 3/4"	Aluminium	210	90	Handknob and locknut
MF000234	MFST-090-RHTR-90-G34-N210	E,R: G 3/4"	Aluminium	210	90	Screw and locknut
MF000235	MFST-090-RMTR-90-G34-N210	E,R: G 3/4"	Aluminium	210	90	Graduated handknob
MF000139	MFST-090-RVSR-90-G34-N350	E,R: G 3/4"	Steel	350	90	Handknob and locknut
MF000236	MFST-090-RHSR-90-G34-N350	E,R: G 3/4"	Steel	350	90	Screw and locknut
MF000237	MFST-090-RMSR-90-G34-N350	E,R: G 3/4"	Steel	350	90	Graduated handknob

FLOW REGULATOR

MFST-190-RVTR

2 WAYS COMPENSATED

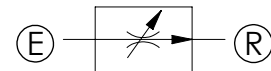
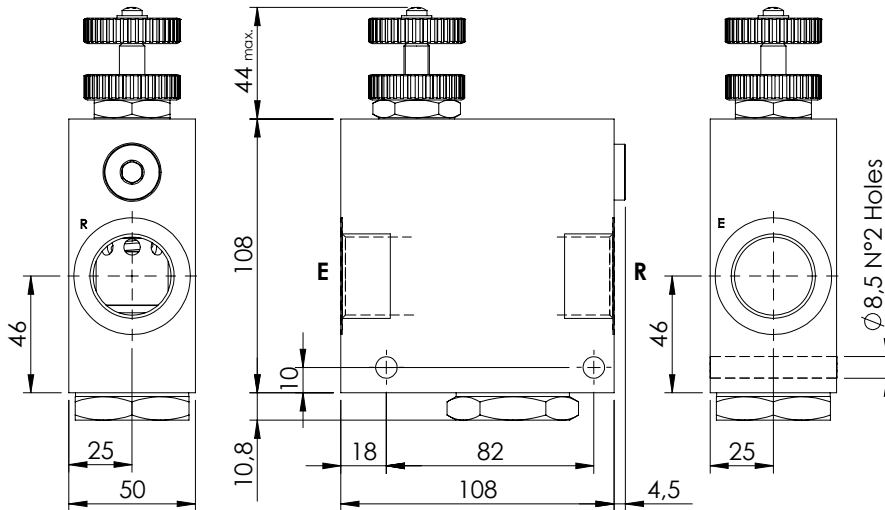
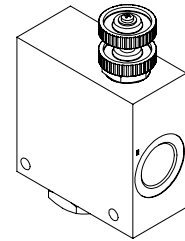

SPECIFICATIONS

Max. operating pressure:	210/350 bar
Rated flow:	190 l/min
Manifold:	Aluminium/Steel
Weight:	1,8/4,0 kg

ADJUSTMENT OPTIONS



NOTES

Regulation: STANDARD

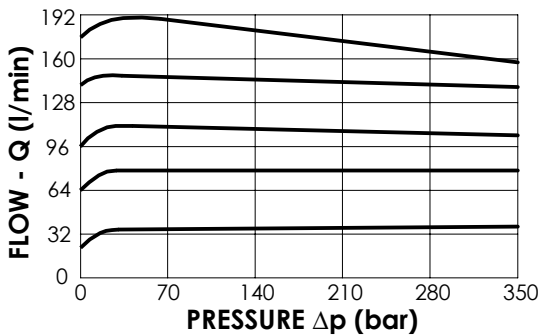

ORDERING CODES

Quick code	Description	Main ports size	Manifold	Max. Pressure (Bar)	Max. inlet flow (l/min)	Adjustment options
MF000253	MFST-190-RVTR-19-G10-N210	E,R: G 1"	Aluminium	210	190	Handknob and locknut
MF000254	MFST-190-RHTR-19-G10-N210	E,R: G 1"	Aluminium	210	190	Screw and locknut
MF000255	MFST-190-RMTR-19-G10-N210	E,R: G 1"	Aluminium	210	190	Graduated handknob
MF000256	MFST-190-RVSR-19-G10-N350	E,R: G 1"	Steel	350	190	Handknob and locknut
MF000257	MFST-190-RHSR-19-G10-N350	E,R: G 1"	Steel	350	190	Screw and locknut
MF000258	MFST-190-RMSR-19-G10-N350	E,R: G 1"	Steel	350	190	Graduated handknob

FLOW REGULATOR

MFST-055-VVTR

**2 WAYS COMPENSATED
WITH CHECK VALVE**

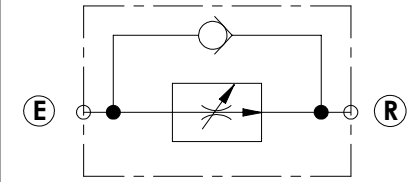
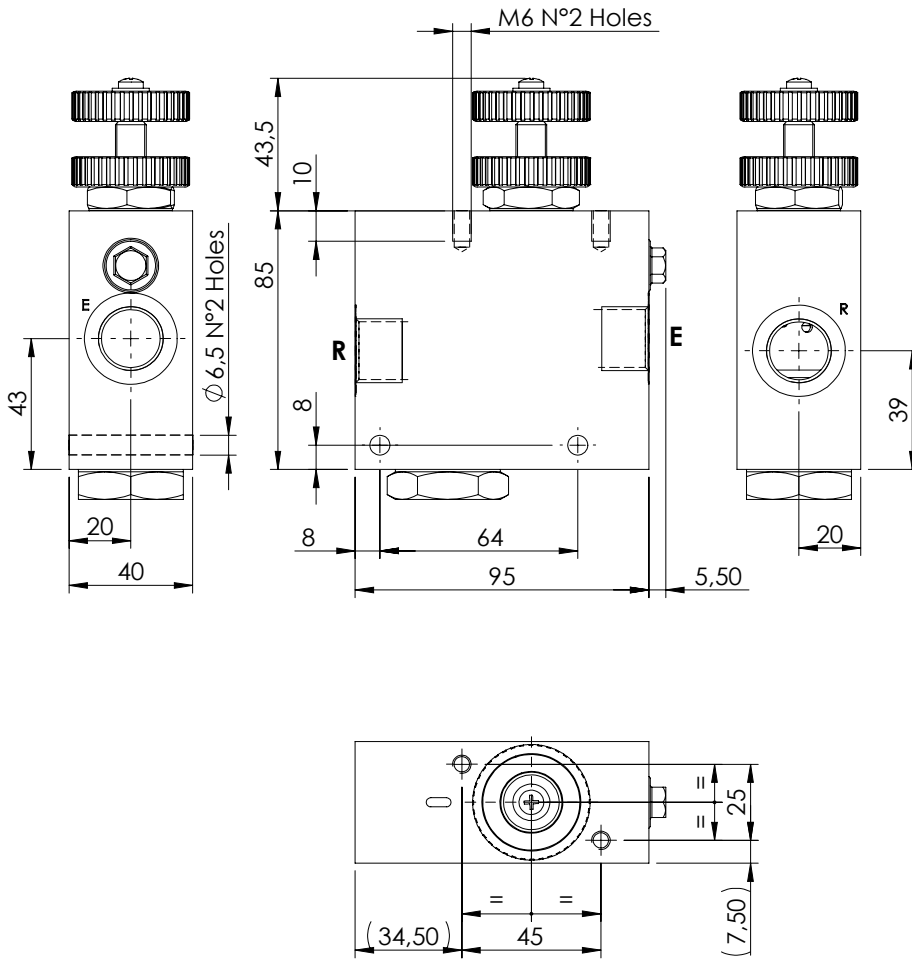
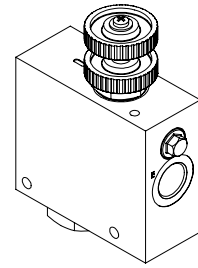

SPECIFICATIONS

Max. operating pressure:	210 bar
Rated flow:	55 l/min
Manifold:	Aluminium
Weight:	1,06 kg

ADJUSTMENT OPTIONS



NOTES

Regulating: FINE

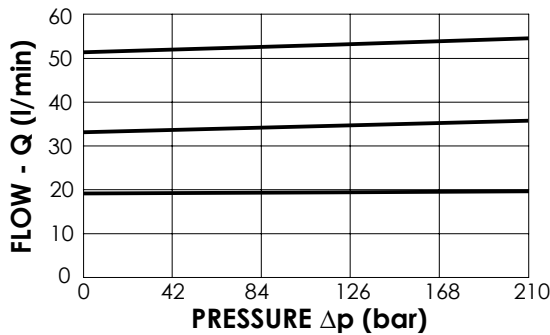

ORDERING CODES

Quick code	Description	Main ports size	Max. inlet flow (l/min)	Adjustment options
MF000131	MFST-055-VVTR-55-G12-N210	G 1/2"	55	Handknob and locknut
MF000375	MFST-055-VHTR-55-G12-N210	G 1/2"	55	Screw and locknut
MF000146	MFST-055-VMTR-55-G12-N210	G 1/2"	55	Graduated handknob

FLOW REGULATOR

MFCT-055-RVTR

3 WAYS COMPENSATED

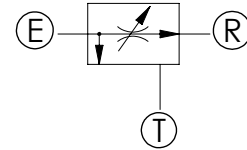
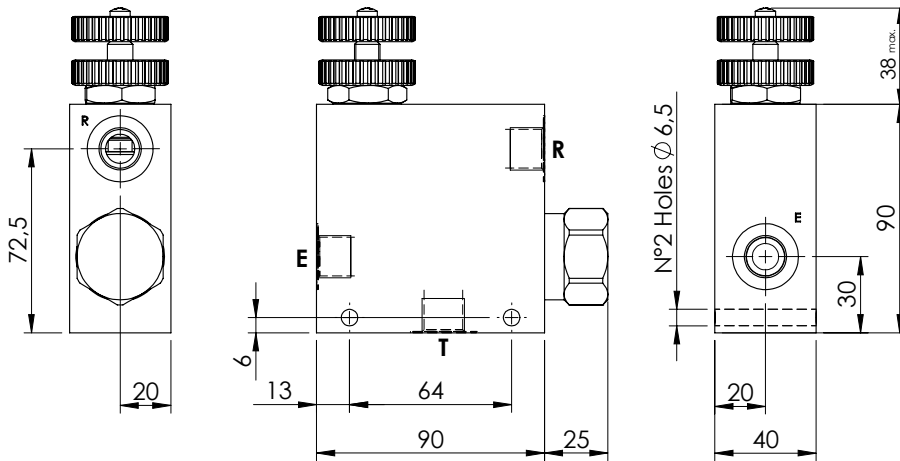
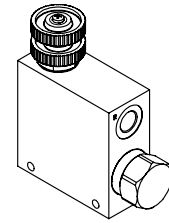
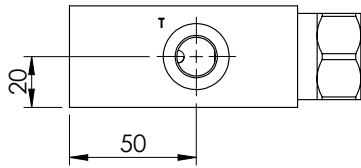

SPECIFICATIONS

Max. operating pressure:	see table
Rated flow:	55 l/min
Manifold:	Aluminium/Steel
Weight:	1,12/2,48 kg

ADJUSTMENT OPTIONS

Handknob and locknut	Screw and locknut	Graduated handknob

NOTES

Regulation sensitivity: FINE

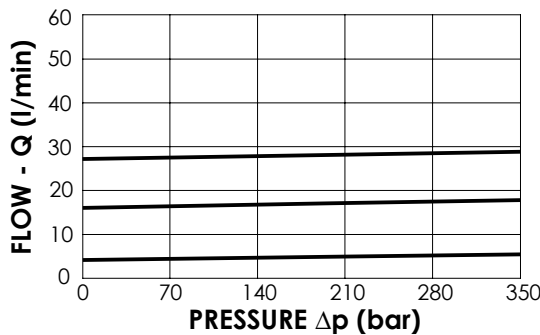

ORDERING CODES

Quick code	Description	Main ports size	Manifold	Max. Pressure (Bar)	Max. reg.flow (l/min)	Max. inlet flow (l/min)	Adjustment options
MF000008	MFCT-055-RVTR-30-G38-N210	G 3/8"	Aluminium	210	30	55	Handknob and locknut
MF000009	MFCT-055-RHTR-30-G38-N210	G 3/8"	Aluminium	210	30	55	Screw and locknut
MF000010	MFCT-055-RMTR-30-G38-N210	G 3/8"	Aluminium	210	30	55	Graduated handknob
MF000089	MFCT-055-RVSR-30-G38-N350	G 3/8"	Steel	350	30	55	Handknob and locknut
MF000090	MFCT-055-RHSR-30-G38-N350	G 3/8"	Steel	350	30	55	Screw and locknut
MF000091	MFCT-055-RMSR-30-G38-N350	G 3/8"	Steel	350	30	55	Graduated handknob

FLOW REGULATOR

MFCT-090-RVTR

3 WAYS COMPENSATED

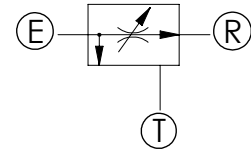
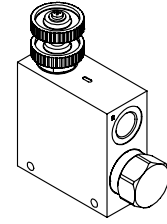
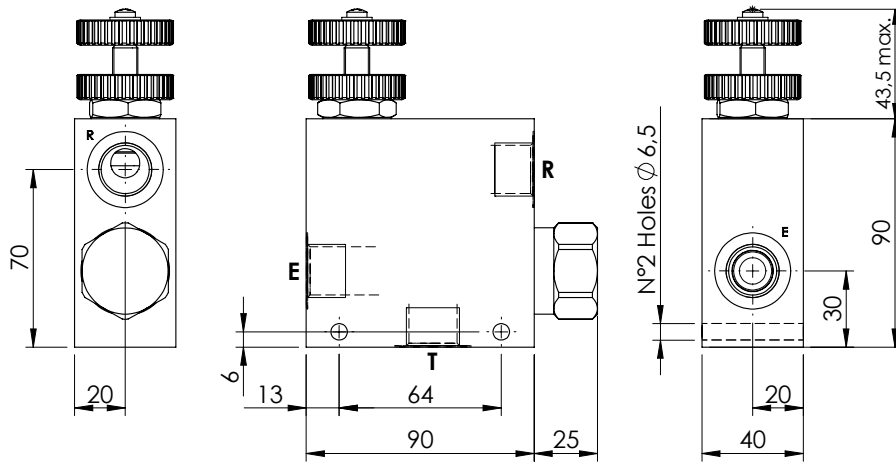
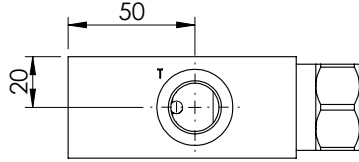

SPECIFICATIONS

Max. operating pressure:	see table
Rated flow:	90 l/min
Manifold:	Aluminium/Steel
Weight:	1,11/2,45 kg

ADJUSTMENT OPTIONS



NOTES

Regulation: FINE

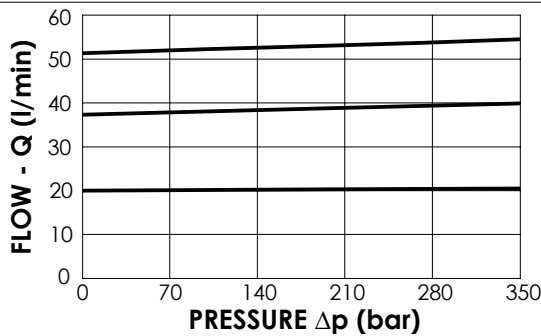

ORDERING CODES

Quick code	Description	Main ports size	Manifold	Max. Pressure (Bar)	Max. reg.flow (l/min)	Max. inlet flow (l/min)	Adjustment options
MF000015	MFCT-090-RVTR-55-G12-N210	G 1/2"	Aluminium	210	55	90	Handknob and locknut
MF000016	MFCT-090-RHTR-55-G12-N210	G 1/2"	Aluminium	210	55	90	Screw and locknut
MF000014	MFCT-090-RMTR-55-G12-N210	G 1/2"	Aluminium	210	55	90	Graduated handknob
MF000095	MFCT-090-RVSR-55-G12-N350	G 1/2"	Steel	350	55	90	Handknob and locknut
MF000096	MFCT-090-RHSR-55-G12-N350	G 1/2"	Steel	350	55	90	Screw and locknut
MF000097	MFCT-090-RMSR-55-G12-N350	G 1/2"	Steel	350	55	90	Graduated handknob

FLOW REGULATOR

MFCT-090-RPZR

3 WAYS COMPENSATED

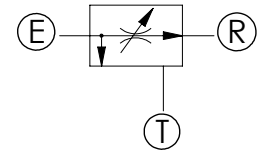
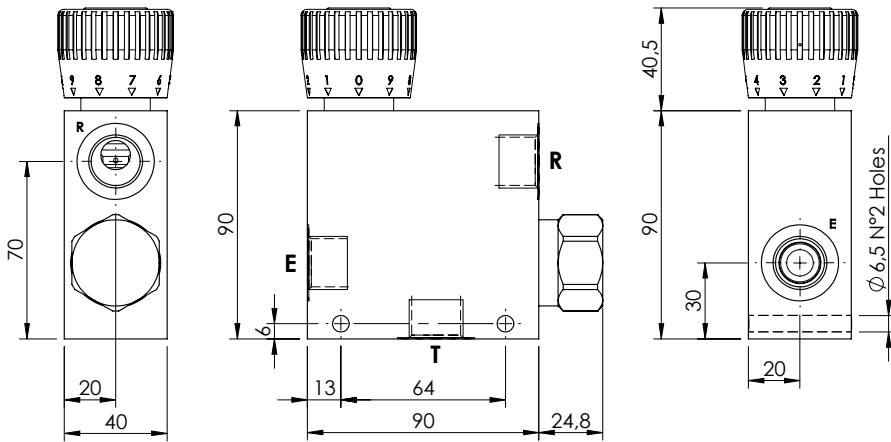
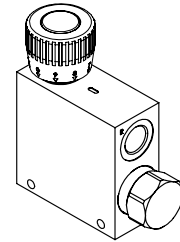
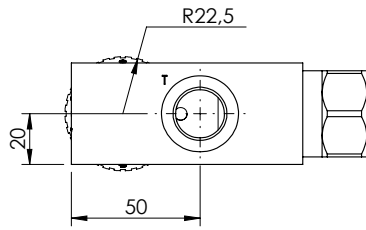

SPECIFICATIONS

Max. operating pressure:	210 bar
Rated flow:	90 l/min
Manifold:	Aluminium
Weight:	0,93 kg

ADJUSTMENT TYPE

Graduated handknob for flow regulation under pressure

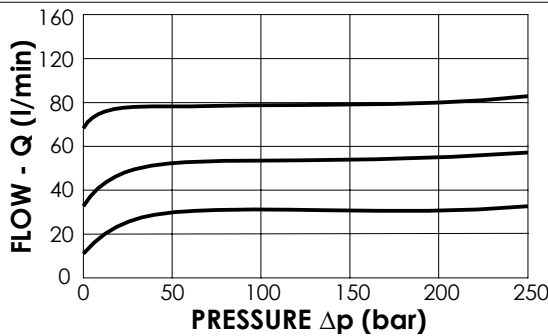
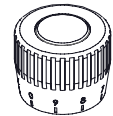

ORDERING CODES

Quick code	Description	Main ports size	Regulated flow range (l/min)	Adjustment type
MF000194	MFCT-090-RPZR-06-G12-N210	G 1/2"	0 - 6	Graduated handknob
MF000195	MFCT-090-RPZR-12-G12-N210	G 1/2"	0 - 12	Graduated handknob
MF000196	MFCT-090-RPZR-25-G12-N210	G 1/2"	0 - 25	Graduated handknob
MF000197	MFCT-090-RPZR-32-G12-N210	G 1/2"	0 - 32	Graduated handknob
MF000198	MFCT-090-RPZR-50-G12-N210	G 1/2"	0 - 50	Graduated handknob
MF000199	MFCT-090-RPZR-63-G12-N210	G 1/2"	0 - 63	Graduated handknob
MF000200	MFCT-090-RPZR-70-G12-N210	G 1/2"	0 - 70	Graduated handknob
MF000201	MFCT-090-RPZR-80-G12-N210	G 1/2"	0 - 80	Graduated handknob

FLOW REGULATOR

MFCT-150-RVTR

3 WAYS COMPENSATED

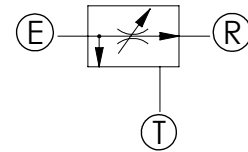
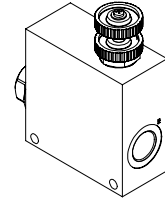
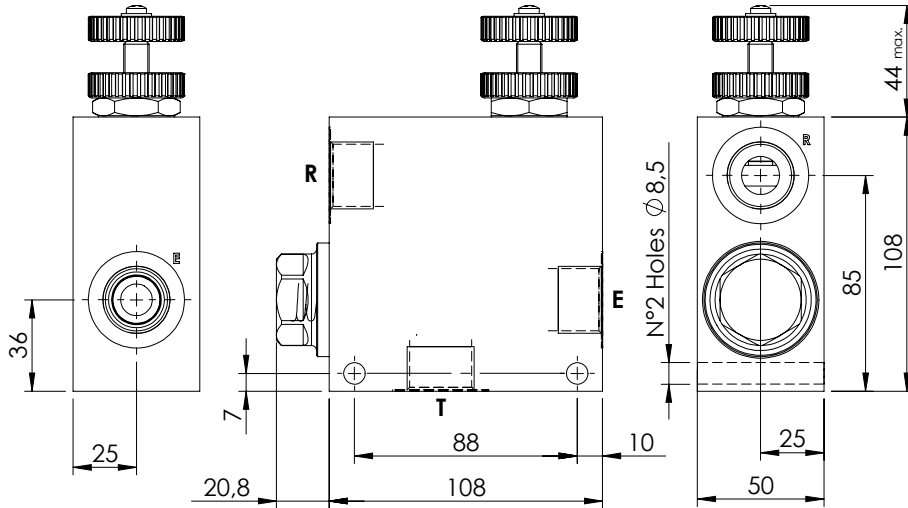
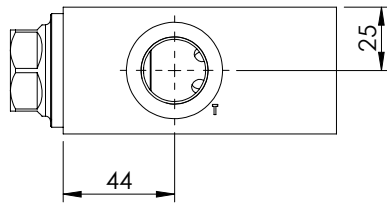

SPECIFICATIONS

Max. operating pressure:	see table
Rated flow:	150 l/min
Manifold:	Aluminium/Steel
Weight:	1,79/4,23 kg

ADJUSTMENT OPTIONS

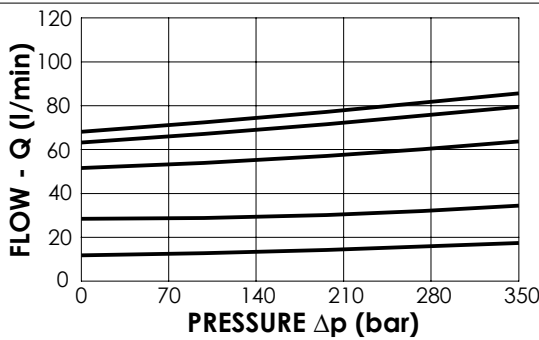

NOTES

Regulation: STANDARD

ORDERING CODES

Quick code	Description	Main ports size	Manifold	Max. Pressure (Bar)	Max. reg.flow (l/min)	Max. inlet flow (l/min)	Adjustment options
MF000031	MFCT-150-RVTR-90-G34-N210	G 3/4"	Aluminium	210	90	150	Handknob and locknut
MF000032	MFCT-150-RHTR-90-G34-N210	G 3/4"	Aluminium	210	90	150	Screw and locknut
MF000033	MFCT-150-RMTR-90-G34-N210	G 3/4"	Aluminium	210	90	150	Graduated handknob
MF000023	MFCT-150-RVSR-90-G34-N350	G 3/4"	Steel	350	90	150	Handknob and locknut
MF000024	MFCT-150-RHSR-90-G34-N350	G 3/4"	Steel	350	90	150	Screw and locknut
MF000025	MFCT-150-RMSR-90-G34-N350	G 3/4"	Steel	350	90	150	Graduated handknob

FLOW REGULATOR

MFCT-280-RVTR

3 WAYS COMPENSATED

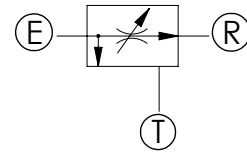
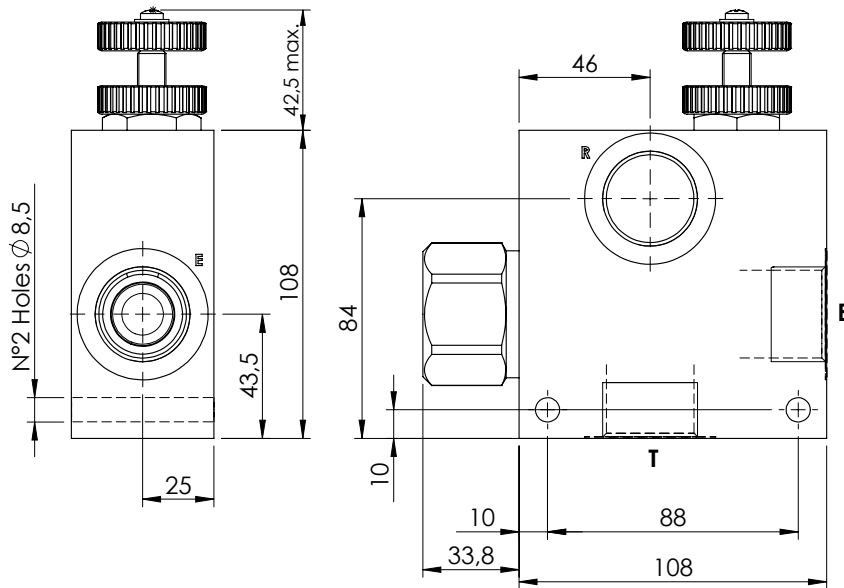
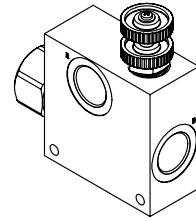
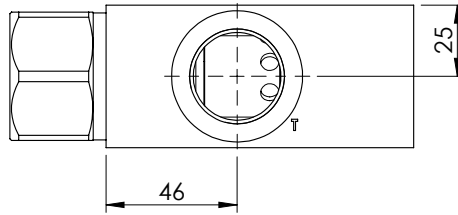

SPECIFICATIONS

Max. operating pressure:	see table
Rated flow:	280 l/min
Manifold:	Aluminium/Steel
Weight:	1,97/4,08 kg

ADJUSTMENT OPTIONS



NOTES

Regulating: STANDARD

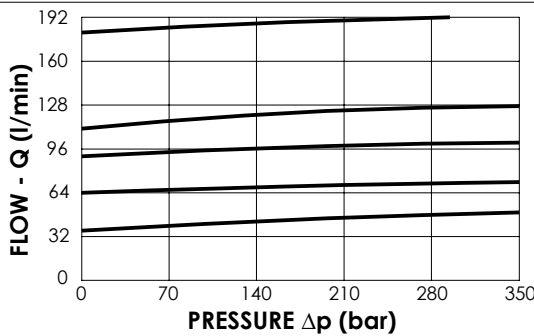

ORDERING CODES

Quick code	Description	Main ports size	Manifold	Max. Pressure (Bar)	Max. reg.flow (l/min)	Max. inlet flow (l/min)	Adjustment options
MF000035	MFCT-280-RVTR-19-G10-N210	G 1"	Aluminium	210	190	280	Handknob and locknut
MF000036	MFCT-280-RHTR-19-G10-N210	G 1"	Aluminium	210	190	280	Screw and locknut
MF000037	MFCT-280-RMTR-19-G10-N210	G 1"	Aluminium	210	190	280	Graduated handknob
MF000026	MFCT-280-RVSR-19-G10-N350	G 1"	Steel	350	190	280	Handknob and locknut
MF000027	MFCT-280-RHSR-19-G10-N350	G 1"	Steel	350	190	280	Screw and locknut
MF000028	MFCT-280-RMSR-19-G10-N350	G 1"	Steel	350	190	280	Graduated handknob

FLOW REGULATOR

MFPT-090-RVTR

**PRESSURE COMPENSATED
PRIORITY FLOW REGULATOR**

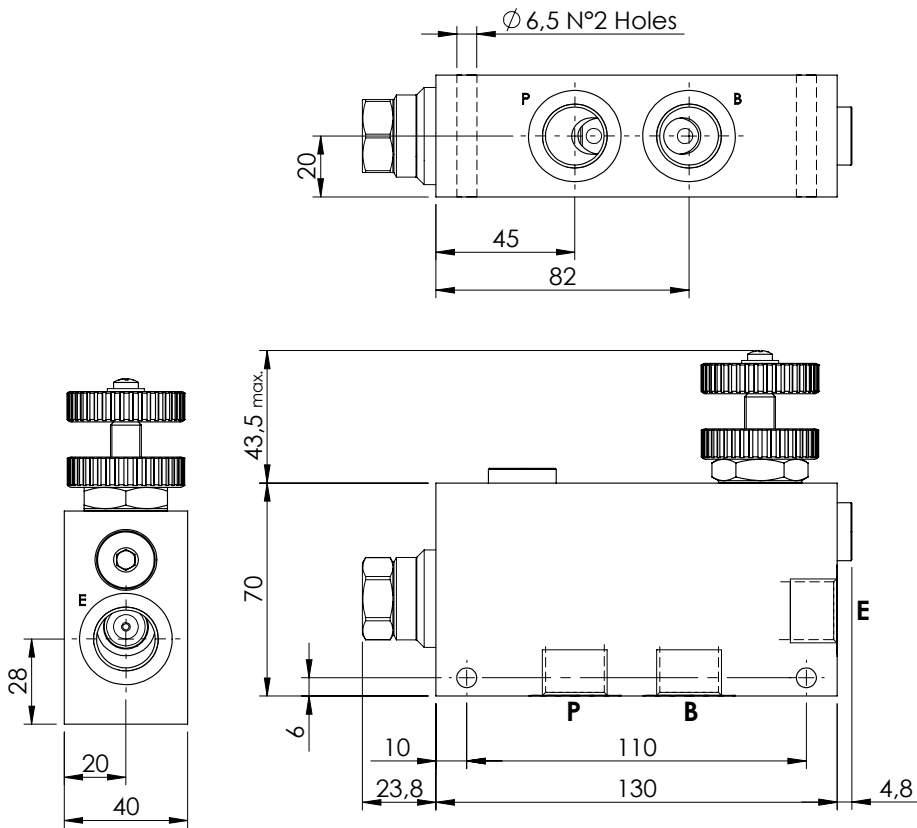
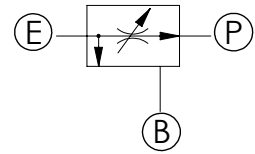
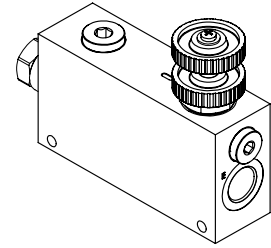

SPECIFICATIONS

Max. operating pressure:	210 bar
Rated flow:	90 l/min
Manifold:	Aluminium
Weight:	1,2 kg

ADJUSTMENT OPTIONS



NOTES

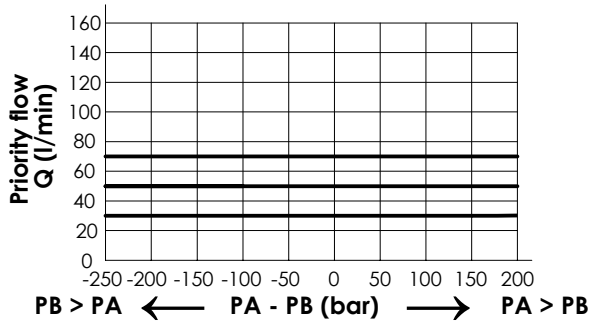

ORDERING CODES

Quick code	Description	Main ports size	Max. inlet flow (l/min)	Max. regulated flow (l/min)	Adjustment options
MF000121	MFPT-090-RVTR-70-G12-N210	E,P,T: G1/2"	90 l/min	70 l/min	Handknob and locknut
MF000136	MFPT-090-RVTR-70-G38-N210	E,P,T: G3/8"	90 l/min	70 l/min	Handknob and locknut

FLOW REGULATOR

MFPT-090-RPZR

**PRESSURE COMPENSATED
PRIORITY FLOW REGULATOR**

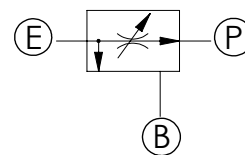
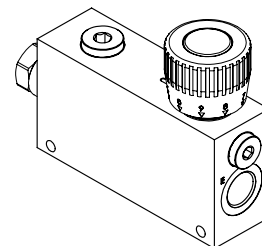
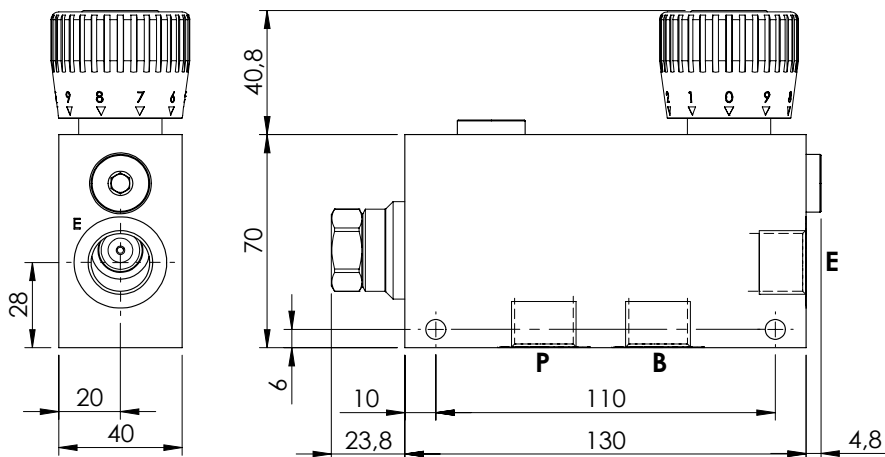
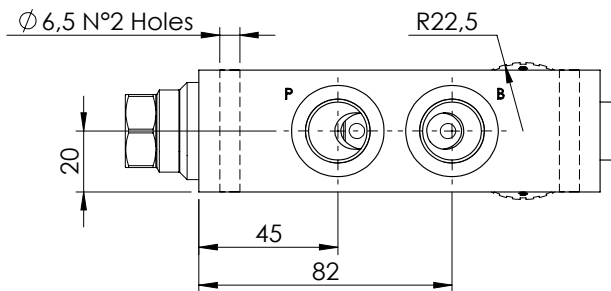

SPECIFICATIONS

Max. operating pressure:	210 bar
Rated flow:	90 l/min
Manifold:	Aluminium
Weight:	1,3 kg

ADJUSTMENT TYPE

Graduated handknob for flow regulation under pressure

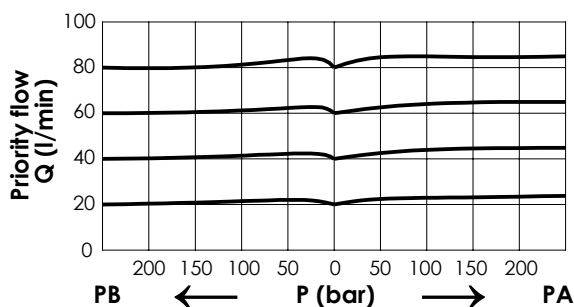
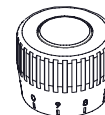

ORDERING CODES

Quick code	Description	Main ports size	Regulated flow range (l/min)	Adjustment type
MF000211	MFPT-090-RPZR-12-G12-N210	G 1/2"	0 - 12	Graduated handknob
MF000212	MFPT-090-RPZR-25-G12-N210	G 1/2"	0 - 25	Graduated handknob
MF000213	MFPT-090-RPZR-32-G12-N210	G 1/2"	0 - 32	Graduated handknob
MF000214	MFPT-090-RPZR-50-G12-N210	G 1/2"	0 - 50	Graduated handknob
MF000215	MFPT-090-RPZR-63-G12-N210	G 1/2"	0 - 63	Graduated handknob
MF000216	MFPT-090-RPZR-70-G12-N210	G 1/2"	0 - 70	Graduated handknob
MF000217	MFPT-090-RPZR-80-G12-N210	G 1/2"	0 - 80	Graduated handknob

FLOW REGULATOR

MFCT-090-RVTN

3 WAYS COMPENSATED FLOW REGULATOR

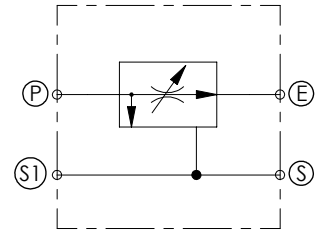
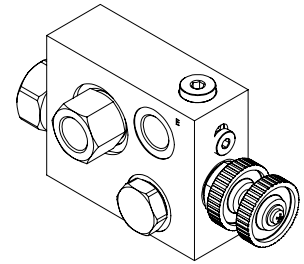
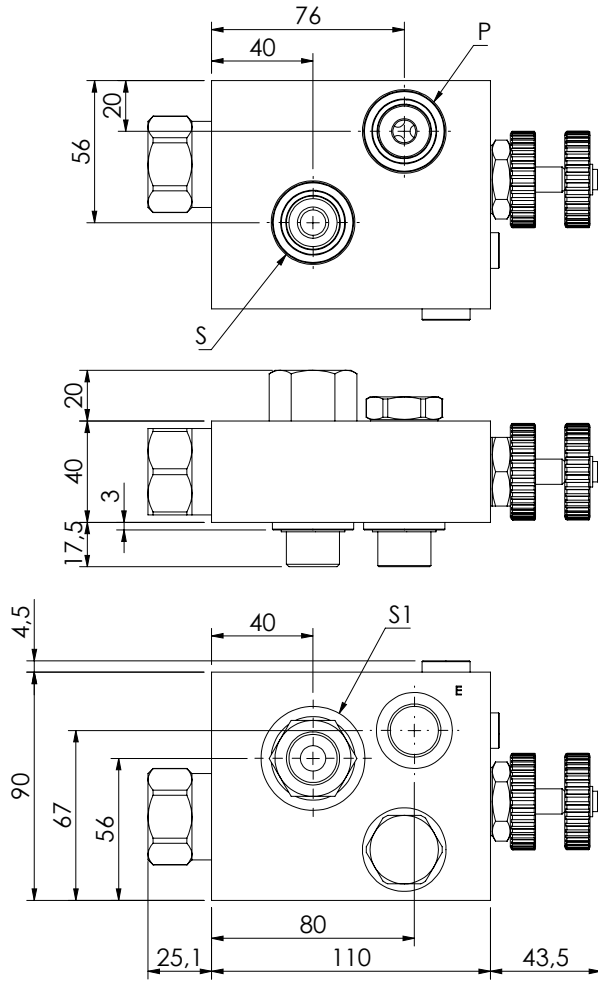

SPECIFICATIONS

Max. operating pressure:	210 bar
Rated flow:	90 l/min
Manifold:	Aluminium
Weight:	1,65 kg

ADJUSTMENT OPTIONS



NOTES

Designed for DANFOSS motors OMP-OMR series.

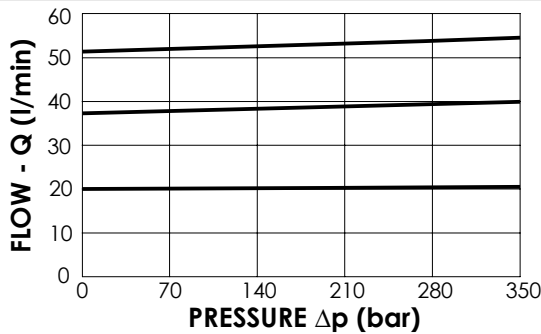

ORDERING CODES

Quick code	Description	Main ports size	Max. Pressure (Bar)	Max. reg.flow (l/min)	Max. inlet flow (l/min)	Adjustment options
MF000373	MFCT-090-RVTN-55-G12-N210	G1/2"	210	55	90	Handknob and locknut

FLOW REGULATOR

MFCT-090-VPZR

**3 WAYS COMPENSATED
WITH CHECK VALVE**

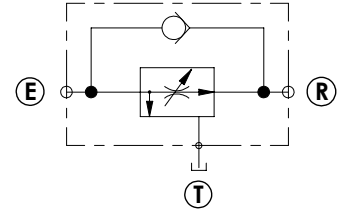
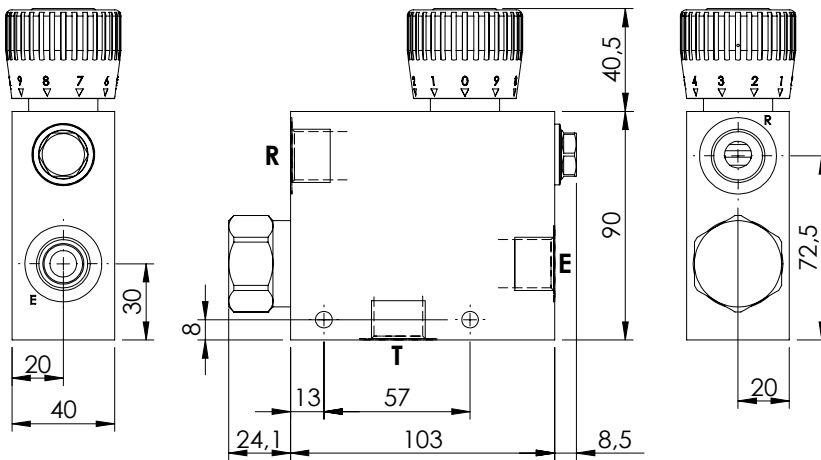
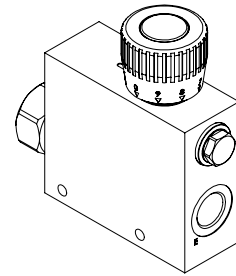
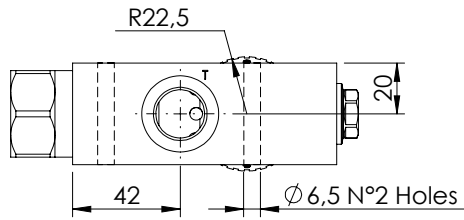

SPECIFICATIONS

Max. operating pressure:	210 bar
Rated flow:	90 l/min
Manifold:	Aluminium
Weight:	1,4 kg

ADJUSTMENT TYPE

Graduated handknob for flow regulation under pressure

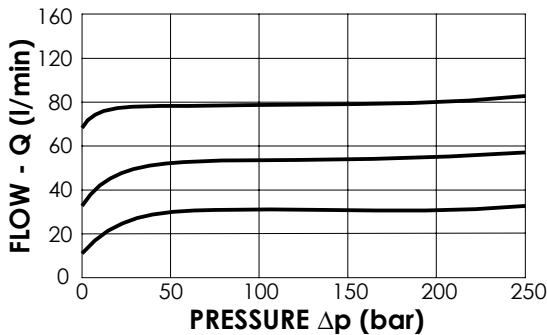
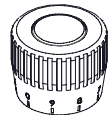

ORDERING CODES

Quick code	Description	Main ports size	Regulated flow range (l/min)	Adjustment type
MF000202	MFCT-090-VPZR-06-G12-N210	G 1/2"	0 - 6	Graduated handknob
MF000203	MFCT-090-VPZR-12-G12-N210	G 1/2"	0 - 12	Graduated handknob
MF000204	MFCT-090-VPZR-25-G12-N210	G 1/2"	0 - 25	Graduated handknob
MF000205	MFCT-090-VPZR-32-G12-N210	G 1/2"	0 - 32	Graduated handknob
MF000206	MFCT-090-VPZR-50-G12-N210	G 1/2"	0 - 50	Graduated handknob
MF000207	MFCT-090-VPZR-63-G12-N210	G 1/2"	0 - 63	Graduated handknob
MF000208	MFCT-090-VPZR-70-G12-N210	G 1/2"	0 - 70	Graduated handknob
MF000209	MFCT-090-VPZR-80-G12-N210	G 1/2"	0 - 80	Graduated handknob

FLOW REGULATOR

MFCT-090-LPZR

**3 WAYS COMPENSATED
WITH RELIEF VALVE**

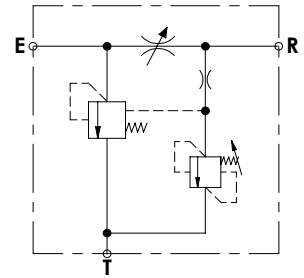
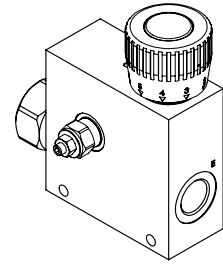
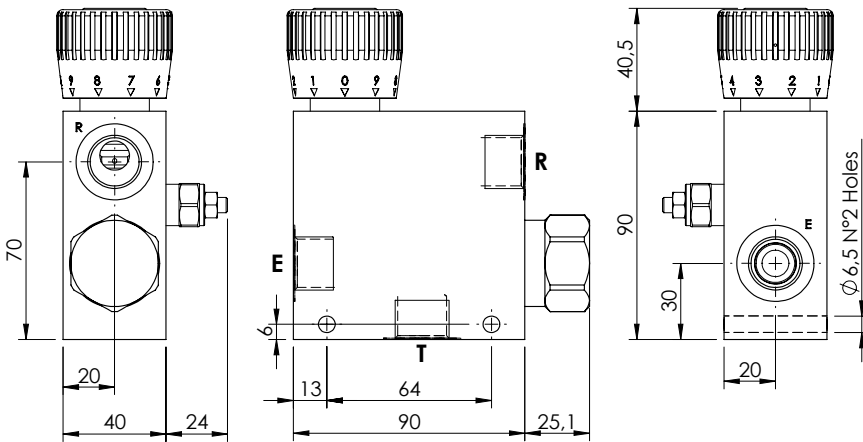
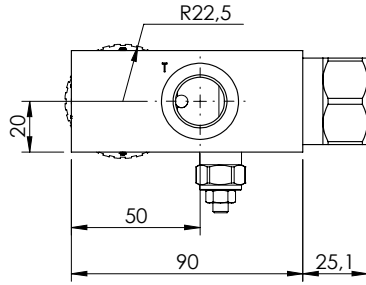

SPECIFICATIONS

Max. operating pressure:	210 bar
Rated flow:	90 l/min
Manifold:	Aluminium
Weight:	0,93 kg

ADJUSTMENT TYPE

Graduated handknob for flow regulation under pressure

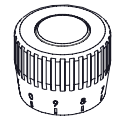

RELIEF VALVE

Setting range:	35 - 210 bar
Standard setting:	210 bar

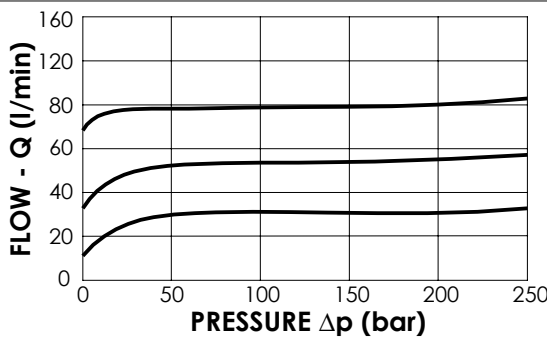

ORDERING CODES

Quick code	Description	Main ports size	Regulated flow range (l/min)	Adjustment type
MF000218	MFCT-090-LPZR-06-G12-N210	G 1/2"	0 - 6	Graduated handknob
MF000219	MFCT-090-LPZR-12-G12-N210	G 1/2"	0 - 12	Graduated handknob
MF000220	MFCT-090-LPZR-25-G12-N210	G 1/2"	0 - 25	Graduated handknob
MF000221	MFCT-090-LPZR-32-G12-N210	G 1/2"	0 - 32	Graduated handknob
MF000222	MFCT-090-LPZR-50-G12-N210	G 1/2"	0 - 50	Graduated handknob
MF000223	MFCT-090-LPZR-63-G12-N210	G 1/2"	0 - 63	Graduated handknob
MF000224	MFCT-090-LPZR-70-G12-N210	G 1/2"	0 - 70	Graduated handknob
MF000225	MFCT-090-LPZR-80-G12-N210	G 1/2"	0 - 80	Graduated handknob

FLOW REGULATOR

MFCT-090-TPZR

**3 WAYS COMPENSATED
BY PASS CHECK VALVE
RELIEF VALVE**

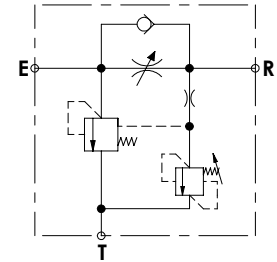
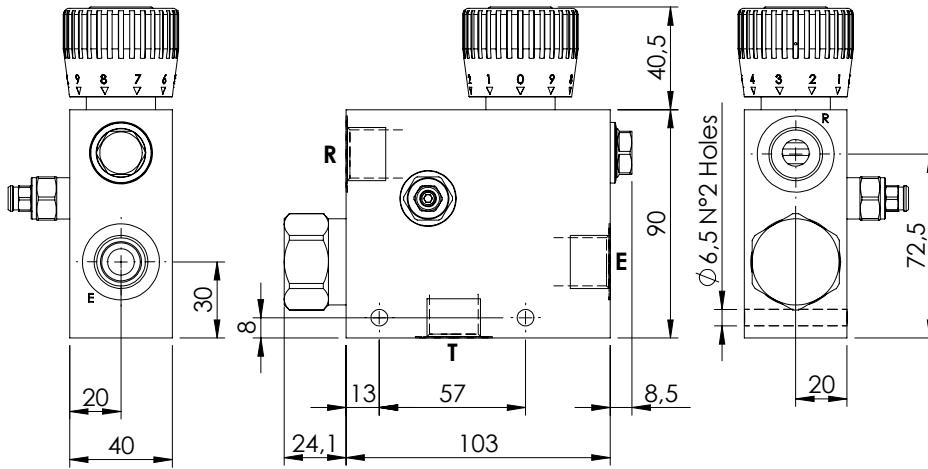
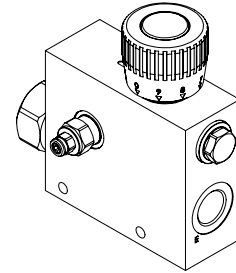
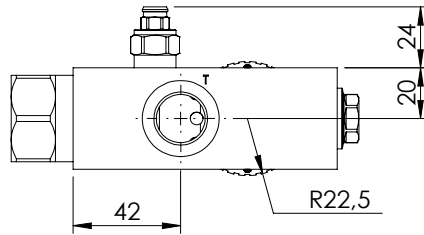

SPECIFICATIONS

Max. operating pressure:	210 bar
Rated flow:	90 l/min
Manifold:	Aluminium
Weight:	1,44 kg

ADJUSTMENT TYPE

Graduated handknob for flow regulation under pressure

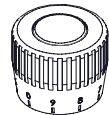

NOTES

Setting range: 35 - 210 bar
Standard setting: 210 bar

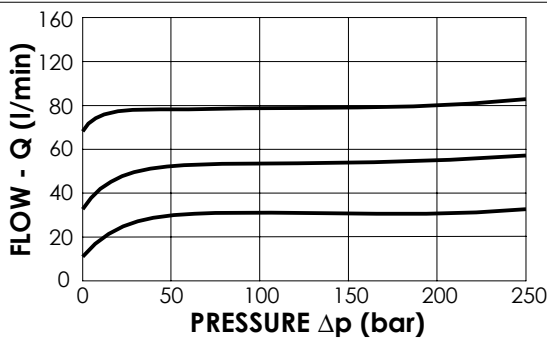

ORDERING CODES

Quick code	Description	Main ports size	Regulated flow range (l/min)	Adjustment type
MF000226	MFCT-090-TPZR-06-G12-N210	G 1/2"	0 - 6	Graduated handknob
MF000227	MFCT-090-TPZR-12-G12-N210	G 1/2"	0 - 12	Graduated handknob
MF000228	MFCT-090-TPZR-25-G12-N210	G 1/2"	0 - 25	Graduated handknob
MF000229	MFCT-090-TPZR-32-G12-N210	G 1/2"	0 - 32	Graduated handknob
MF000230	MFCT-090-TPZR-50-G12-N210	G 1/2"	0 - 50	Graduated handknob
MF000231	MFCT-090-TPZR-63-G12-N210	G 1/2"	0 - 63	Graduated handknob
MF000232	MFCT-090-TPZR-70-G12-N210	G 1/2"	0 - 70	Graduated handknob
MF000233	MFCT-090-TPZR-80-G12-N210	G 1/2"	0 - 80	Graduated handknob

FLOW REGULATOR



MFCT-090-MPTR

**3 WAYS COMPENSATED
WITH RELIEF VALVE AND
ELECTRIC UNLOADING**

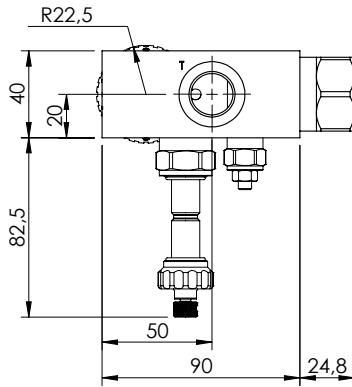

M7 coil type to be ordered separately

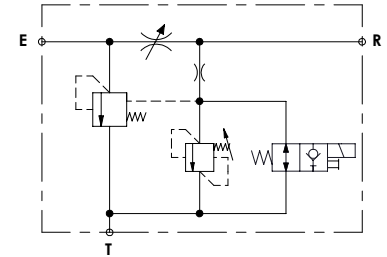
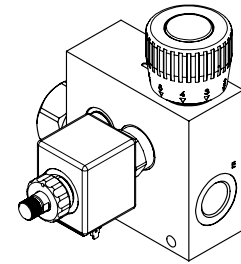
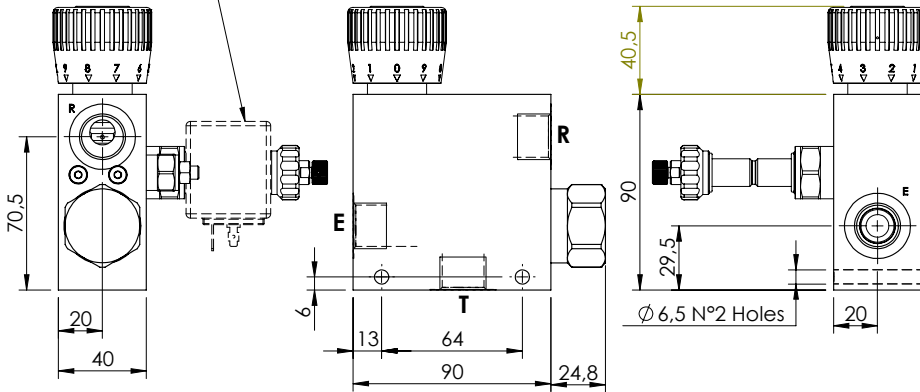

SPECIFICATIONS

Max. operating pressure:	210 bar
Rated flow:	90 l/min
Manifold:	Aluminium
Weight:	0,93 kg

ADJUSTMENT TYPE

Graduated handknob for flow regulation under pressure

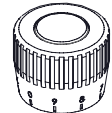

RELIEF VALVE

Setting range:	35 - 210 bar
Standard setting:	210 bar

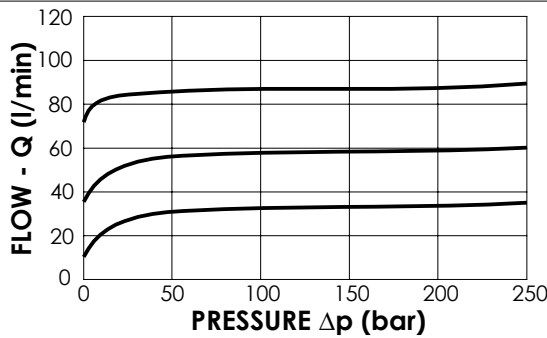

ORDERING CODES

Quick code	Description	Main ports size	Regulated flow range (l/min)	Adjustment type
MF000298	MFCT-090-MPTR-06-G12-N210	G 1/2"	0 - 6	Graduated handknob
MF000299	MFCT-090-MPTR-12-G12-N210	G 1/2"	0 - 12	Graduated handknob
MF000300	MFCT-090-MPTR-25-G12-N210	G 1/2"	0 - 25	Graduated handknob
MF000301	MFCT-090-MPTR-32-G12-N210	G 1/2"	0 - 32	Graduated handknob
MF000302	MFCT-090-MPTR-50-G12-N210	G 1/2"	0 - 50	Graduated handknob
MF000303	MFCT-090-MPTR-63-G12-N210	G 1/2"	0 - 63	Graduated handknob
MF000304	MFCT-090-MPTR-70-G12-N210	G 1/2"	0 - 70	Graduated handknob
MF000305	MFCT-090-MPTR-80-G12-N210	G 1/2"	0 - 80	Graduated handknob

FLOW REGULATOR

MFCT-280-MVTR

**3 WAYS COMPENSATED
WITH RELIEF VALVE AND
ELECTRIC UNLOADING**

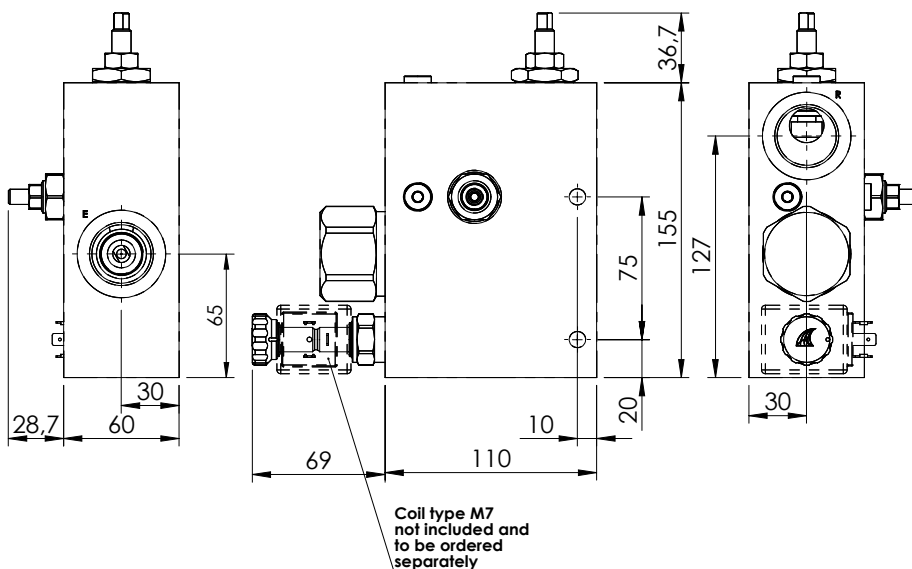
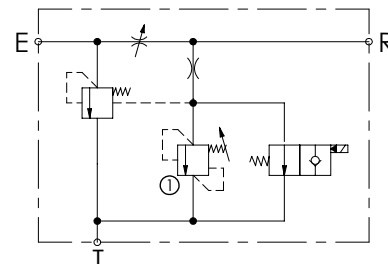
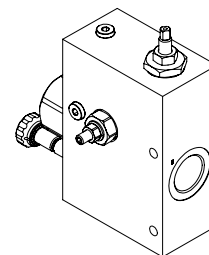
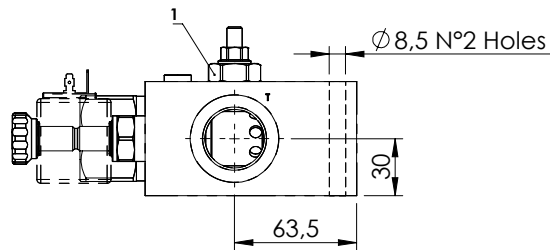

SPECIFICATIONS

Max. operating pressure:	250 bar
Rated flow:	280 l/min
Regulated flow:	190 l/min
Manifold:	Aluminium
Weight:	3,24 kg
Coil:	M7

ADJUSTMENT OPTIONS



NOTES

-For options see pag. 22.00.000.

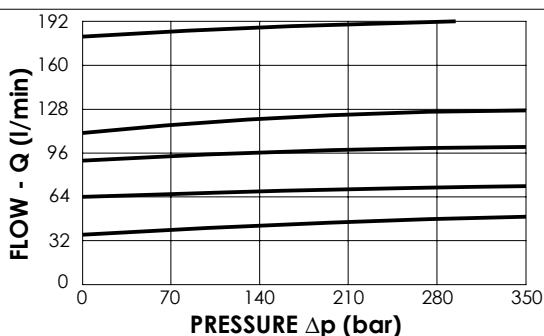

ORDERING CODES

Quick code	Description	Main ports size	Standard setting (bar, Q=l/min)	Adjustment range (bar)	Pressure increase (bar)
MF000143	MFCT-280-MVTR-19-G10-N250	R,E,T: G 1"	240	140-350	142

FLOW REGULATOR

BPNN-025-LLEU

SOLENOID OPERATED VALVES
STANDARD INTEGRATED CIRCUITS

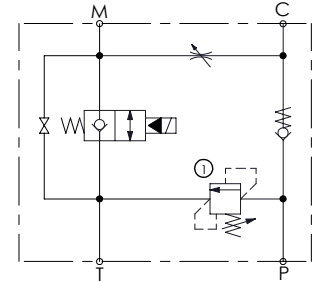
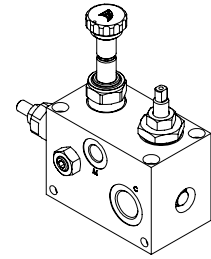
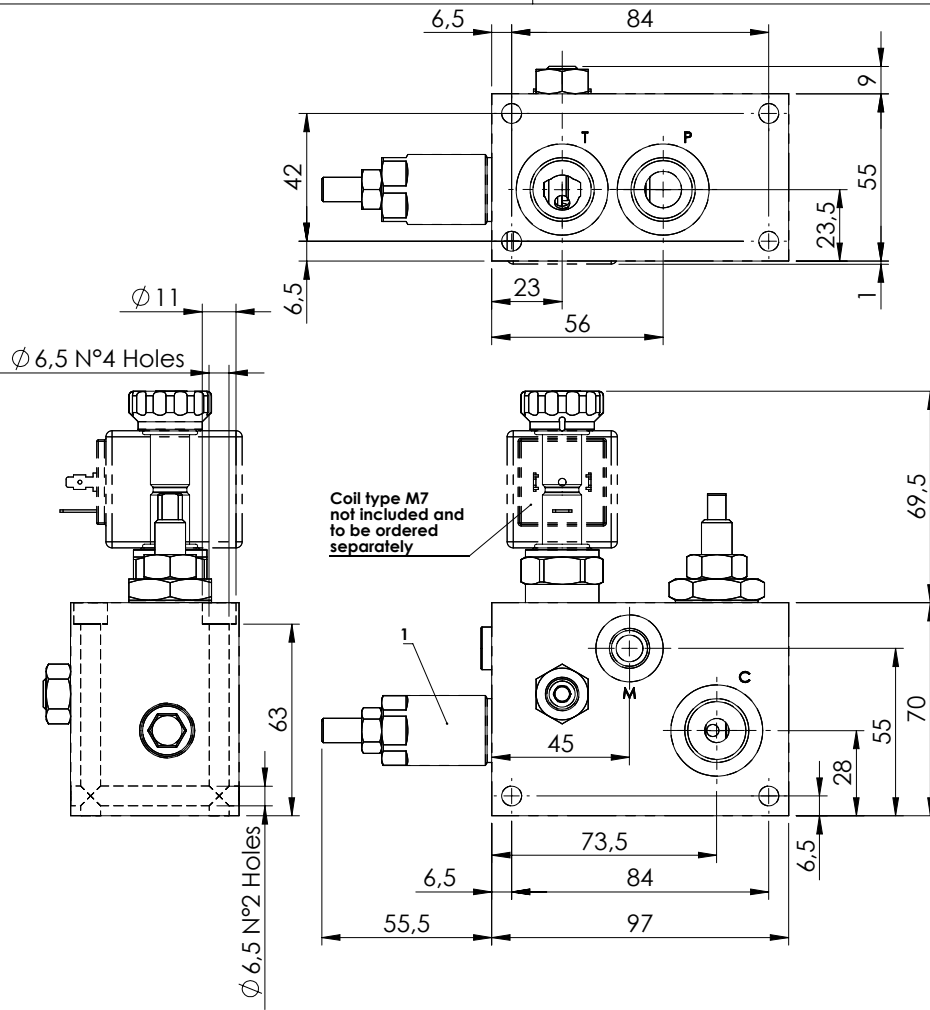

SPECIFICATIONS

Max. operating pressure:	350 bar
Rated flow:	25 l/min
Manifold:	Aluminium
Weight:	1,3 kg
Coil:	M7

ADJUSTMENT OPTIONS

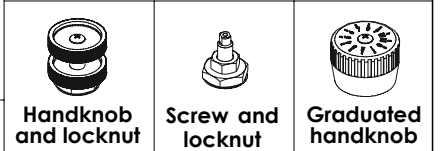

NOTES

-For options see pag. 22.00.000.

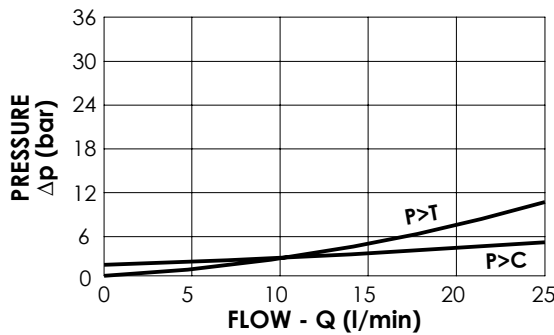

ORDERING CODES

Quick code	Description	Main ports size	Standard setting (bar, Q=5 l/min)	Adjust. range (bar)	Pressure increase (bar)	Adjust. options
BP000081	BPNN-025-LLEU-G12-N200	P,T,C:G1/2" M:G1/4"	200	50-210	42	Screw and locknut

FLOW REGULATOR

MFCT-150-LHTR

**3 WAYS COMPENSATED
WITH RELIEF VALVE**

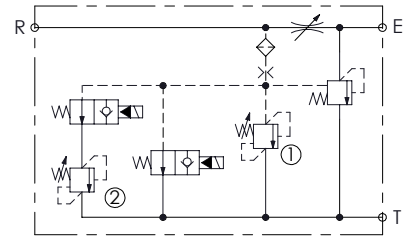
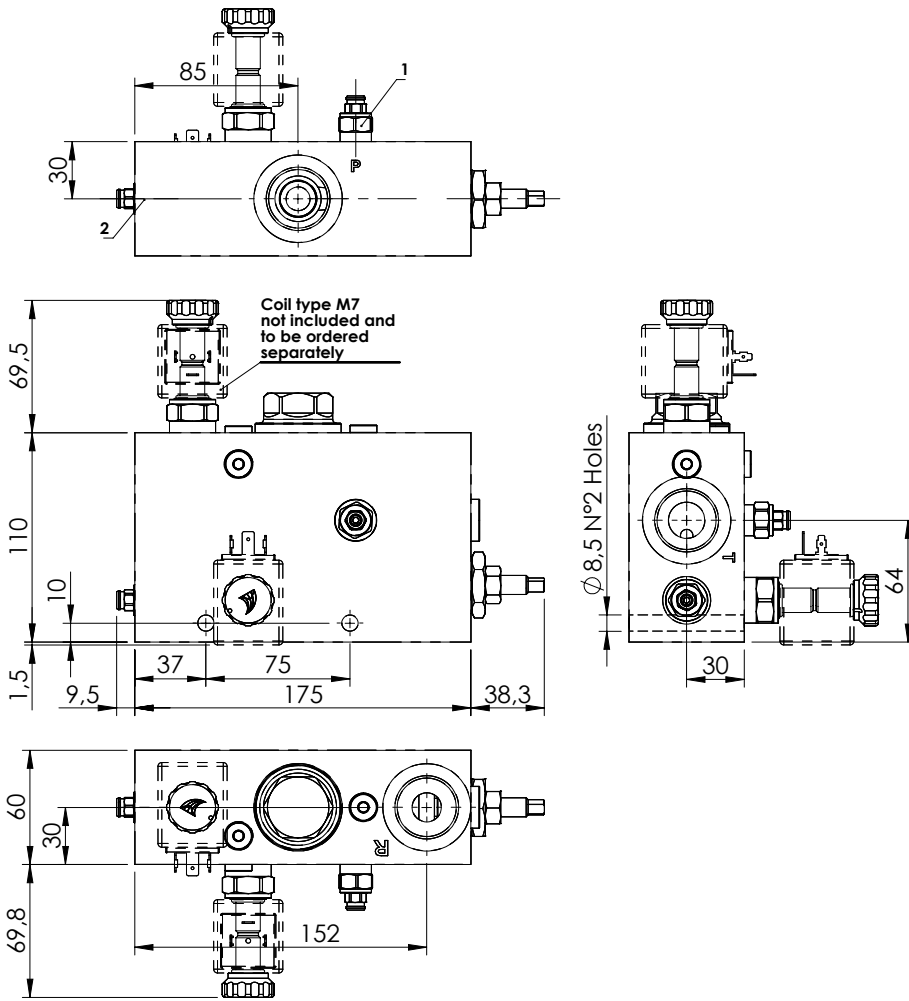
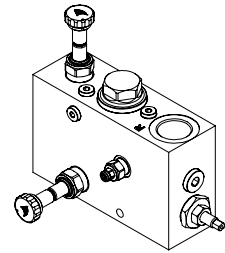

SPECIFICATIONS

Max. operating pressure:	210 bar
Rated flow:	150 l/min
Regulated Flow:	90 l/min
Manifold:	Aluminium
Weight:	3,48 kg
Coil:	M7

ADJUSTMENT OPTIONS

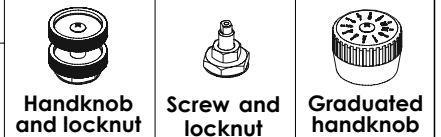

NOTES

-For options see pag. 22.00.000.

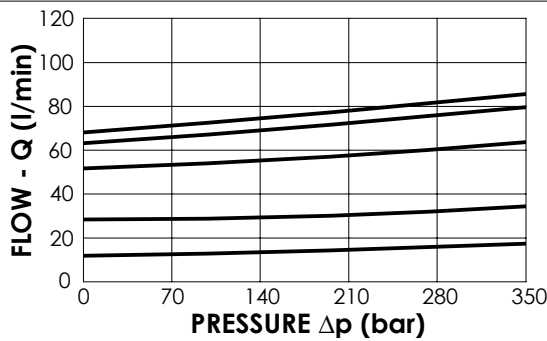

ORDERING CODES

Quick code	Description	Main ports size	Standard setting (bar, Q=5 l/min)	Adjustment range (bar)	Pressure increase (bar/turn)
MF000344	MFCT-150-LHTR-90-G10-N210	R,E,T: G 1"	① 170 ② 150	① 100-200 ② 100-200	① 75 ② 75

FLOW REGULATOR

MFPT-100-RHAR

PRESSURE COMPENSATED PRIORITY FLOW REGULATOR

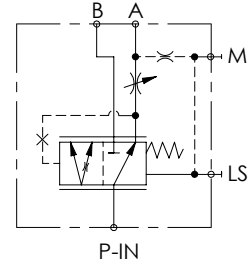
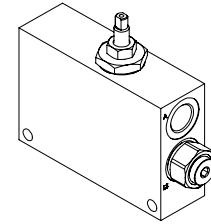
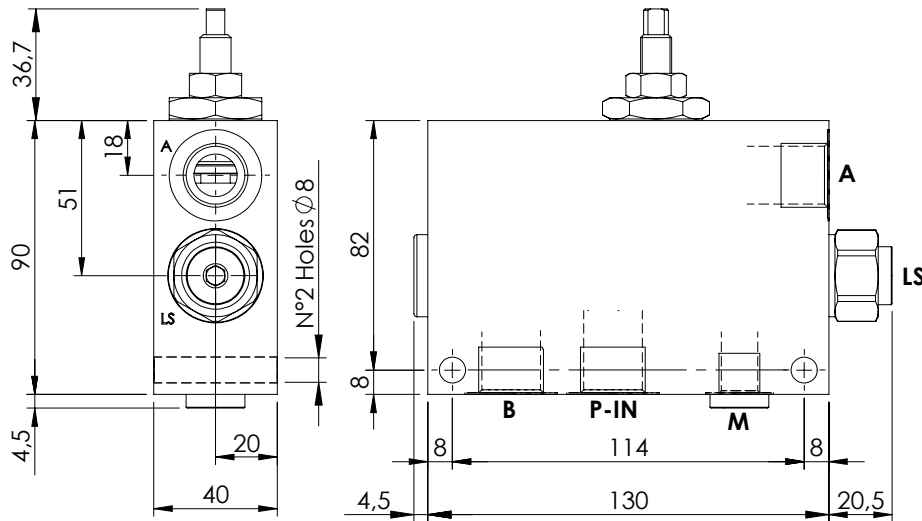
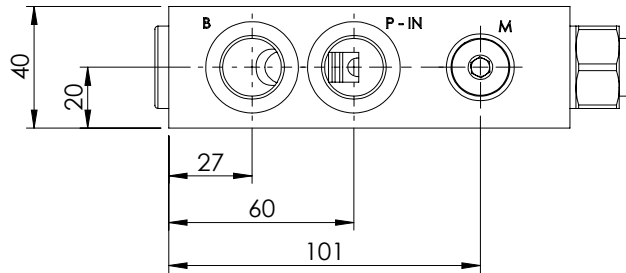

SPECIFICATIONS

Max. operating pressure:	350 bar
Rated flow:	100 l/min
Manifold:	Steel
Weight:	3,38 kg

ADJUSTMENT OPTIONS

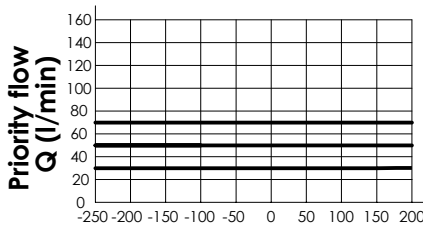

PB > PA ← PA - PB → PA > PB (bar)

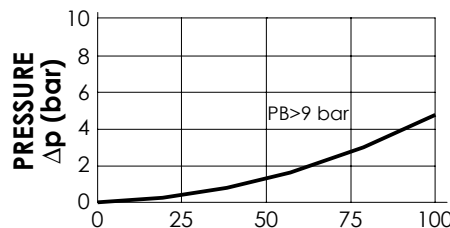

FLOW - Q (l/min)

NOTES

- For correct operation 8-9 bar must be present in port A. For open centre or low pressure systems a 9 bar check valve should be fitted in port A, see page 61.
- Spool switching can be influenced by flexing or stressing the valve body. It is recommended to fit spacers on the mounting bolts between the valve and the mounting surface.
- For options see pag. 22.00.000.

ORDERING CODES

Quick code	Description	Main ports size	Max. inlet flow (l/min)	Max. regulated flow (l/min)	Adjustment options
MF000069	MFPT-100-RHAR-85-G12-N350	P-IN, A, B: G1/2" LS, M: G1/4"	100	85	Screw and locknut

FLOW REGULATOR

MFPT-200-RHAR

PRESSURE COMPENSATED PRIORITY

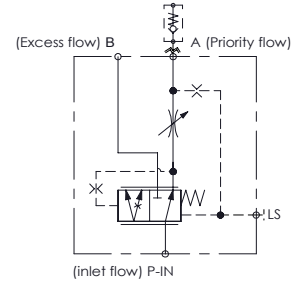
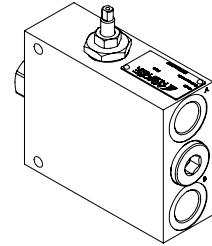
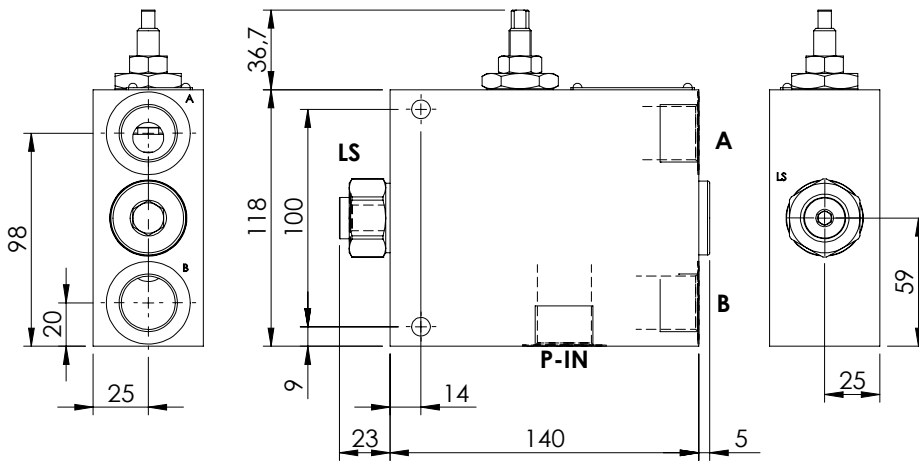
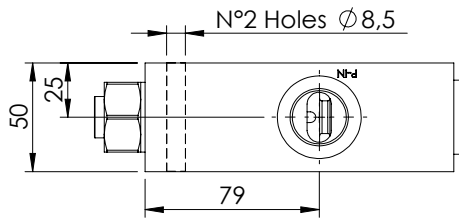

SPECIFICATIONS

Max. operating pressure:	350 bar
Rated flow:	200 l/min
Regulated Flow:	1-140 l/min
Manifold:	Zinc plated steel
Weight:	4,9 kg

ADJUSTMENT OPTIONS



Screw and locknut

NOTES

-For options see pag. 22.00.000.

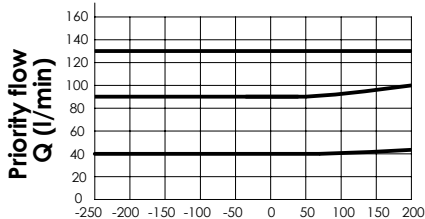

PB > PA ← PA = PB → PA > PB (bar)

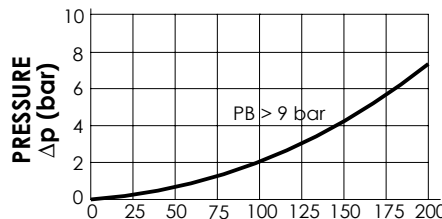

ORDERING CODES

Quick code	Description	Main ports size	Adjustment options
MF000141	MFPT-200-RHAR-14-G34-N350	P-IN,A,B: G 3/4" LS: G 1/4"	Screw and locknut

FLOW REGULATOR

MFPT-300-RHAR

**PRESSURE COMPENSATED
PRIORITY**

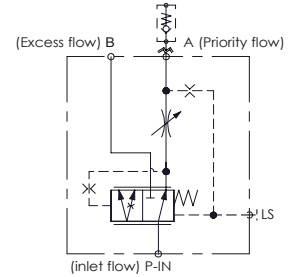
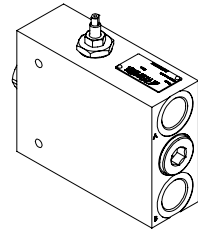
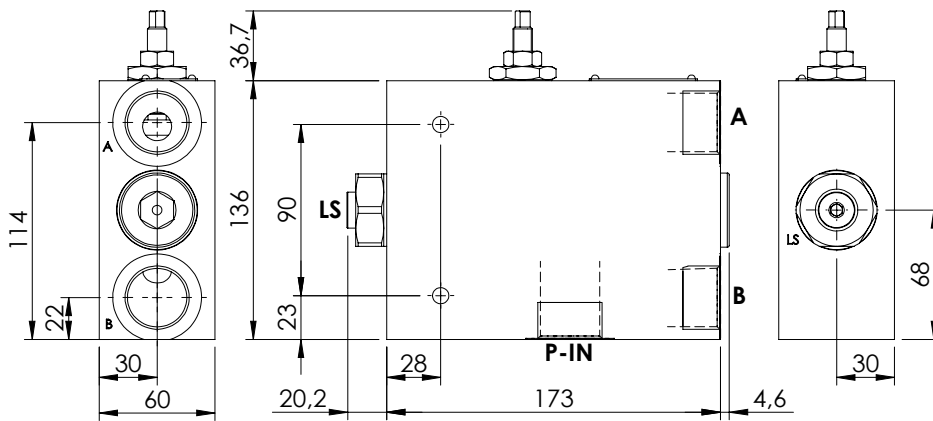
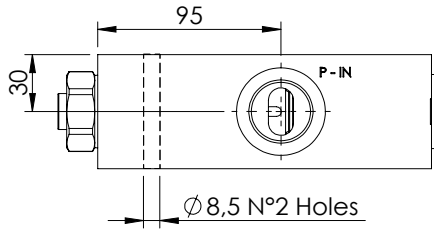

SPECIFICATIONS

Max. operating pressure:	350 bar
Rated flow:	300 l/min
Regulated Flow:	1-220 l/min
Manifold:	Zinc plated steel
Weight:	4,9 kg

ADJUSTMENT OPTIONS



Screw and locknut

NOTES

-For options see pag. 22.00.000.

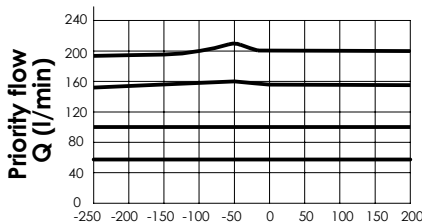

PB > PA ← PA - PB → PA > PB
(bar)

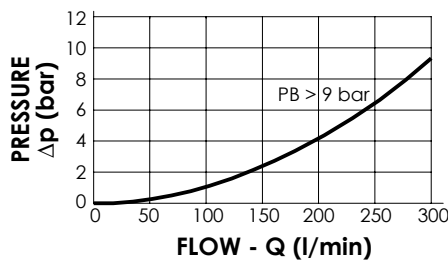

ORDERING CODES

Quick code	Description	Main ports size	Adjustment options
MF000283	MFPT-300-RHAR-20-G10-N350	P-IN,A,B: G 1" LS: G 1/4"	Screw and locknut

FLOW REGULATOR

MFPT-100-MHAR

PRESSURE COMPENSATED PRIORITY FLOW REGULATOR FOR AUXILIARY CIRCUITS

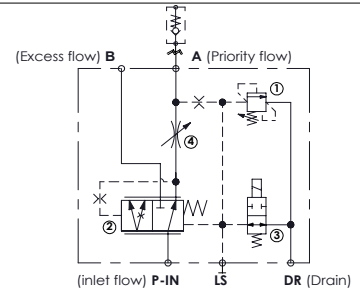
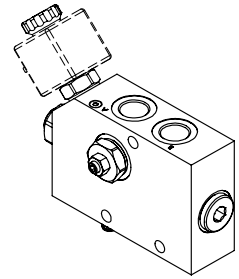
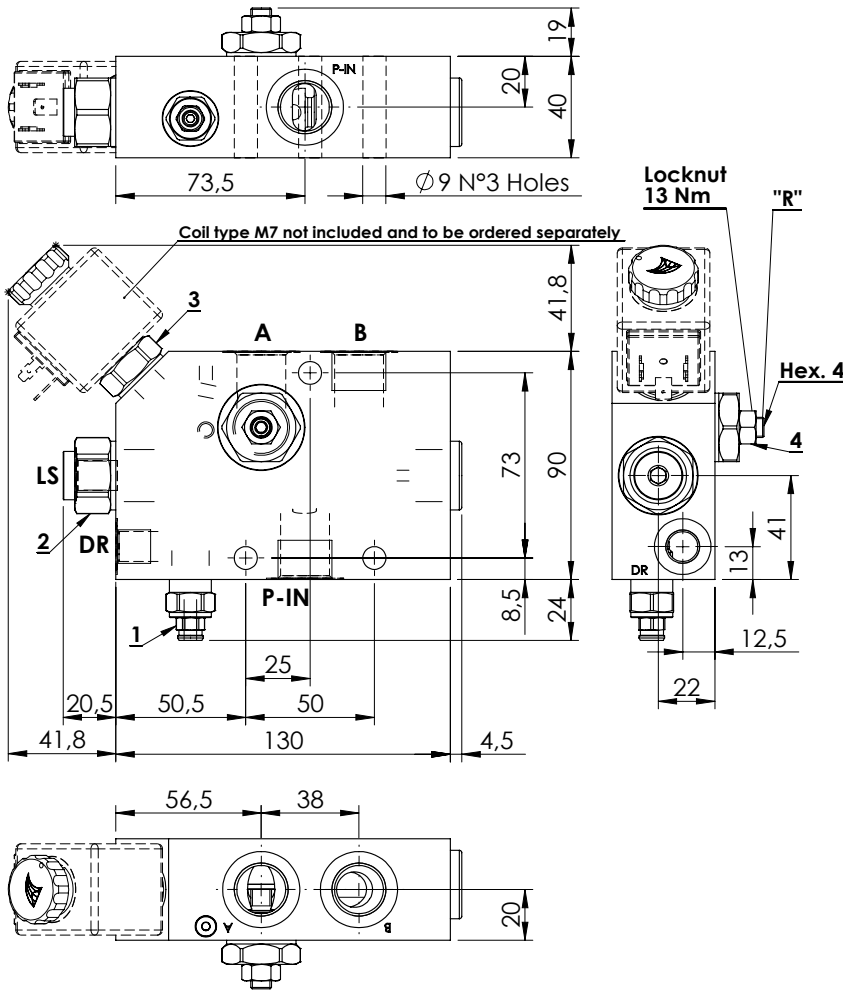

SPECIFICATIONS

Max. operating pressure:	350 bar
Rated flow:	100 l/min
Regulated Flow:	1.5 - 85 l/min
Manifold:	Zinc plated steel
Weight:	3,4 kg
Coil:	M7

NOTES

- Turn screw "R" anti-clockwise to increase regulated flow.
- Drain flow when de-energized 2 l/min.
- Max back pressure admitted on "DR" line 1,5 bar.
- For correct operation 8-9 bar must be present in port A. For open centre or low pressure systems a 9 bar check valve should be fitted in port A .
- Spool switching can be influenced by flexing or stressing the valve body. It is recommended to fit spacers on the mounting bolts between the valve and the mounting surface.
- See chapter four for suitable check valves.

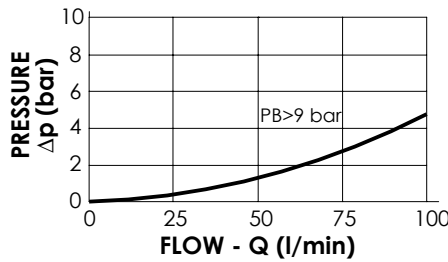
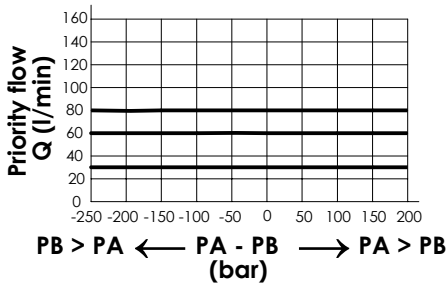

ORDERING CODES

Quick code	Description	Main ports size	Setting range (bar)	Standard setting (bar)	Adjustment (bar/turn)
MF000053	MFPT-100-MHAR-85-G12-N210	P-IN, A,B: G 1/2" DR,LS: G 1/4"	100 - 200	200	75
MF000054	MFPT-100-MHAR-85-G12-N350	P-IN, A,B: G 1/2" DR,LS: G 1/4"	150 - 350	350	165

FLOW REGULATOR

MFPT-200-MHAR

PRESSURE COMPENSATED PRIORITY FLOW REGULATOR FOR AUXILIARY CIRCUITS

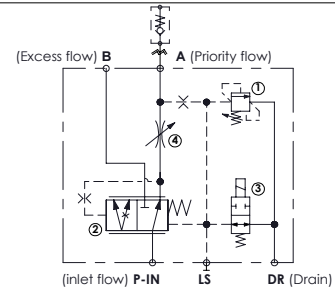
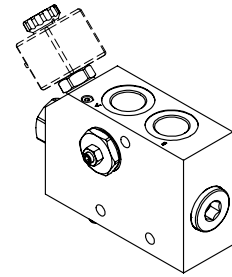
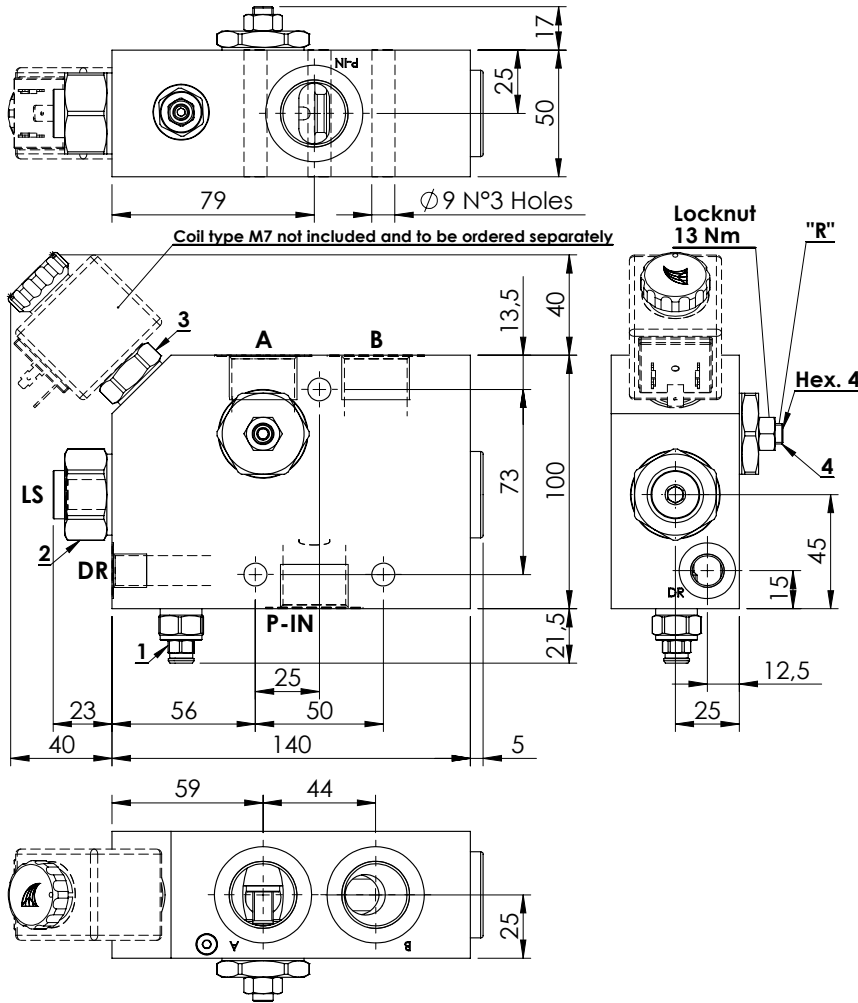

SPECIFICATIONS

Max. operating pressure:	350 bar
Rated flow:	200 l/min
Regulated Flow:	1,5 - 140 l/min
Manifold:	Zinc plated steel
Weight:	4,9 kg
Coil:	M7

NOTES

- Turn screw "R" anti-clockwise to increase regulated flow.
- Drain flow when de-energized 2 l/min.
- Max back pressure admitted on "DR" line 1,5 bar.
- For correct operation 8-9 bar must be present in port A. For open centre or low pressure systems a 9 bar check valve should be fitted in port A .
- Spool switching can be influenced by flexing or stressing the valve body. It is recommended to fit spacers on the mounting bolts between the valve and the mounting surface.
- See chapter four for suitable check valves.

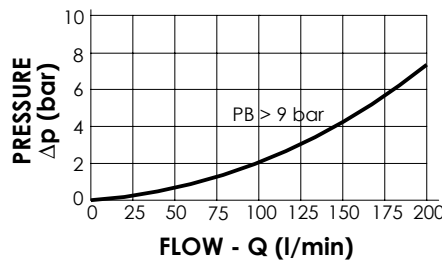
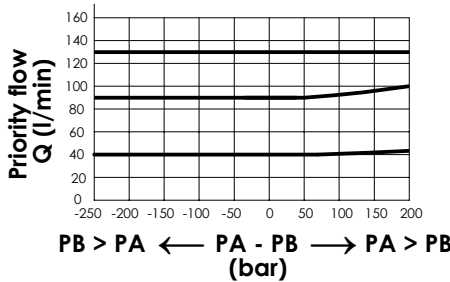

ORDERING CODES

Quick code	Description	Main ports size	Setting range (bar)	Standard setting (bar)	Adjustment (bar/turn)
MF000055	MFPT-200-MHAR-14-G34-N210	P-IN, A,B: G 3/4" DR,LS: G 1/4"	100 - 200	200	75
MF000056	MFPT-200-MHAR-14-G34-N350	P-IN, A,B: G 3/4" DR,LS: G 1/4"	150 - 350	350	165

FLOW REGULATOR

MFPT-300-MHAR

PRESSURE COMPENSATED PRIORITY FLOW REGULATOR FOR AUXILIARY CIRCUITS

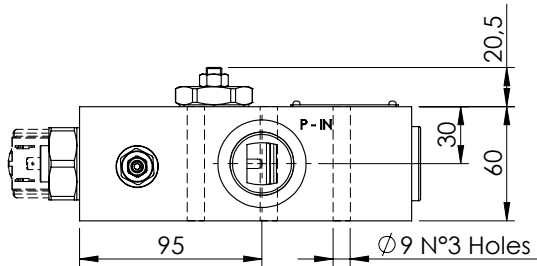

Coil type M7 not included and to be ordered separately

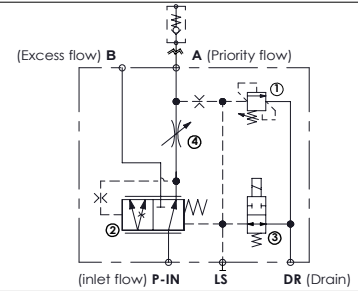
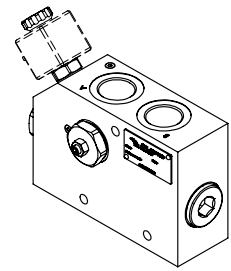
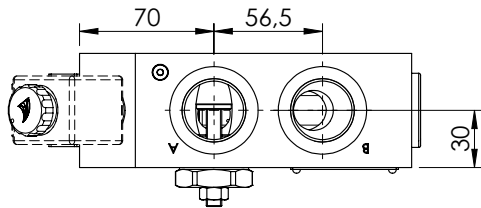
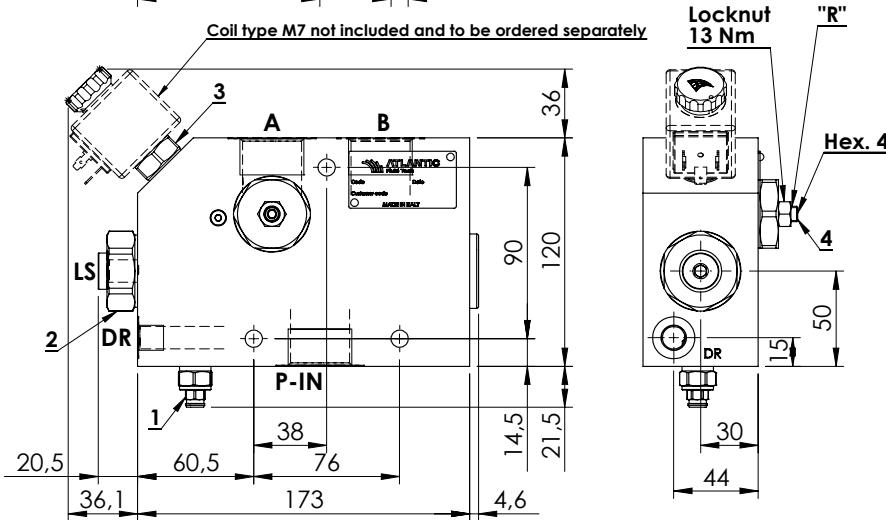

SPECIFICATIONS

Max. operating pressure:	350 bar
Rated flow:	300 l/min
Regulated Flow:	1,5 - 220 l/min
Manifold:	Zinc plated steel
Weight:	8,6 kg
Coil:	M7

NOTES

- Turn screw "R" anti-clockwise to increase regulated flow.
- Drain flow when de-energized 2 l/min.
- Max back pressure admitted on "DR" line 1,5 bar.
- For correct operation 8-9 bar must be present in port A. For open centre or low pressure systems a 9 bar check valve should be fitted in port A .
- Spool switching can be influenced by flexing or stressing the valve body. It is recommended to fit spacers on the mounting bolts between the valve and the mounting surface.
- See chapter four for suitable check valves.

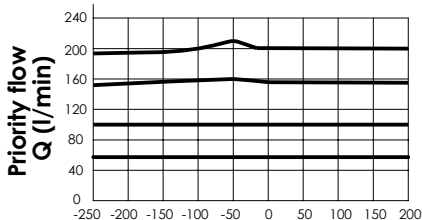

PB > PA ← PA - PB → PA > PB (bar)

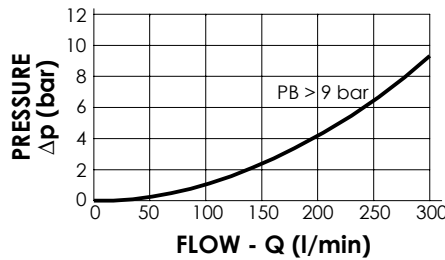

ORDERING CODES

Quick code	Description	Main ports size	Setting range (bar)	Standard setting (bar)	Adjustment (bar/turn)
MF000057	MFPT-300-MHAR-22-G10-N210	P-IN, A,B: G 1" DR,LS: G 1/4"	100 - 200	200	75
MF000058	MFPT-300-MHAR-22-G10-N350	P-IN, A,B: G 1" DR,LS: G 1/4"	150 - 350	350	165

FLOW REGULATOR

MFPT-400-MHAR

PRESSURE COMPENSATED PRIORITY FLOW REGULATOR FOR AUXILIARY CIRCUITS

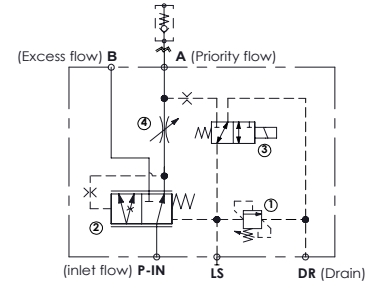
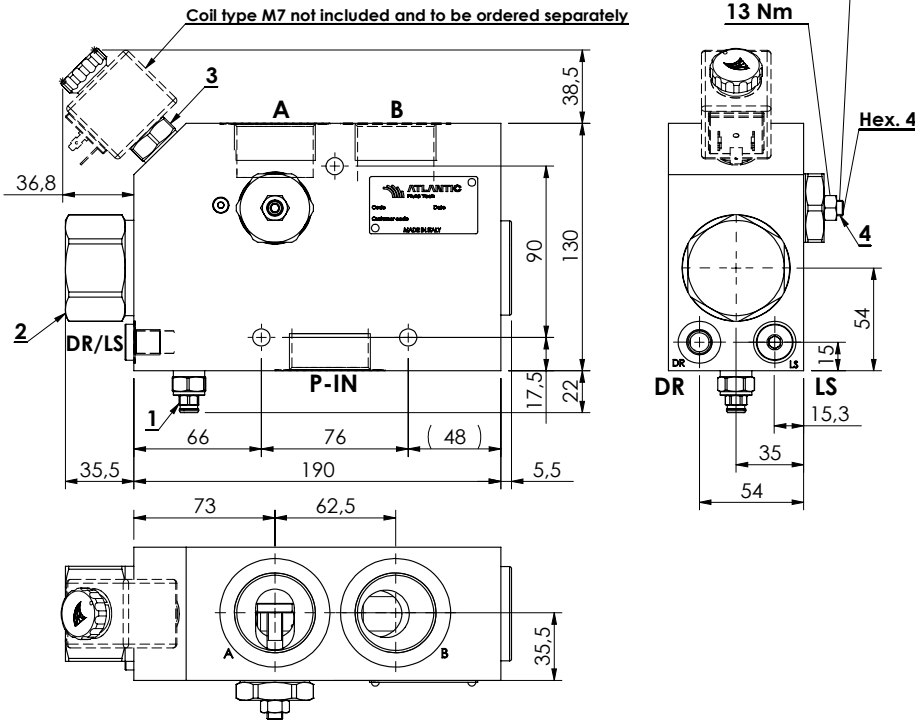
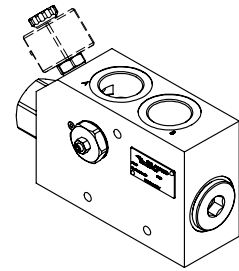
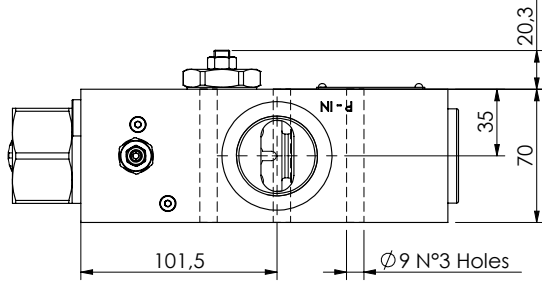

SPECIFICATIONS

Max. operating pressure:	350 bar
Rated flow:	400 l/min
Regulated Flow:	1,5 - 300 l/min
Manifold:	Zinc plated steel
Weight:	11,4 kg
Coil:	M7

NOTES

- Turn screw "R" anti-clockwise to increase regulated flow.
- Drain flow when de-energized 2,5 l/min.
- Max back pressure admitted on "DR" line 1,5 bar.
- For correct operation 8-9 bar must be present in port A. For open centre or low pressure systems a 9 bar check valve should be fitted in port A .
- Spool switching can be influenced by flexing or stressing the valve body. It is recommended to fit spacers on the mounting bolts between the valve and the mounting surface.
- See chapter four for suitable check valves.

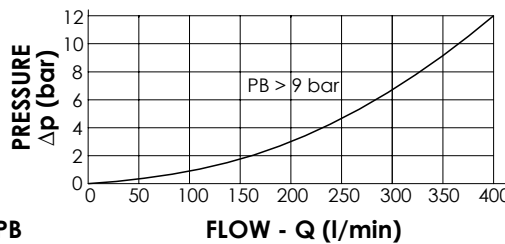
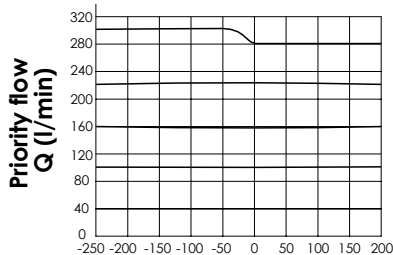

ORDERING CODES

Quick code	Description	Main ports size	Setting range (bar)	Standard setting (bar)	Adjustment (bar/turn)
MF000071	MFPT-400-MHAR-30-G11-N210	P-IN, A, B: G 1"-1/4 DR, LS: G 1/4"	100 - 200	200	75
MF000073	MFPT-400-MHAR-30-G11-N350	P-IN, A, B: G 1"-1/4 DR, LS: G 1/4"	150 - 350	350	165

FLOW REGULATOR

MFTT-100-MHAR

**PRESSURE COMPENSATED PRIORITY
TWO PUMPS SYSTEM
FLOW REGULATOR FOR
AUXILIARY CIRCUITS**

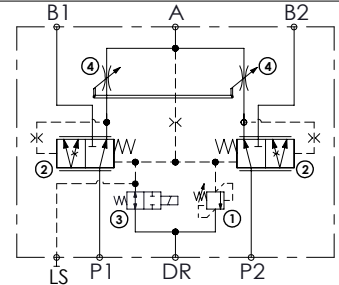
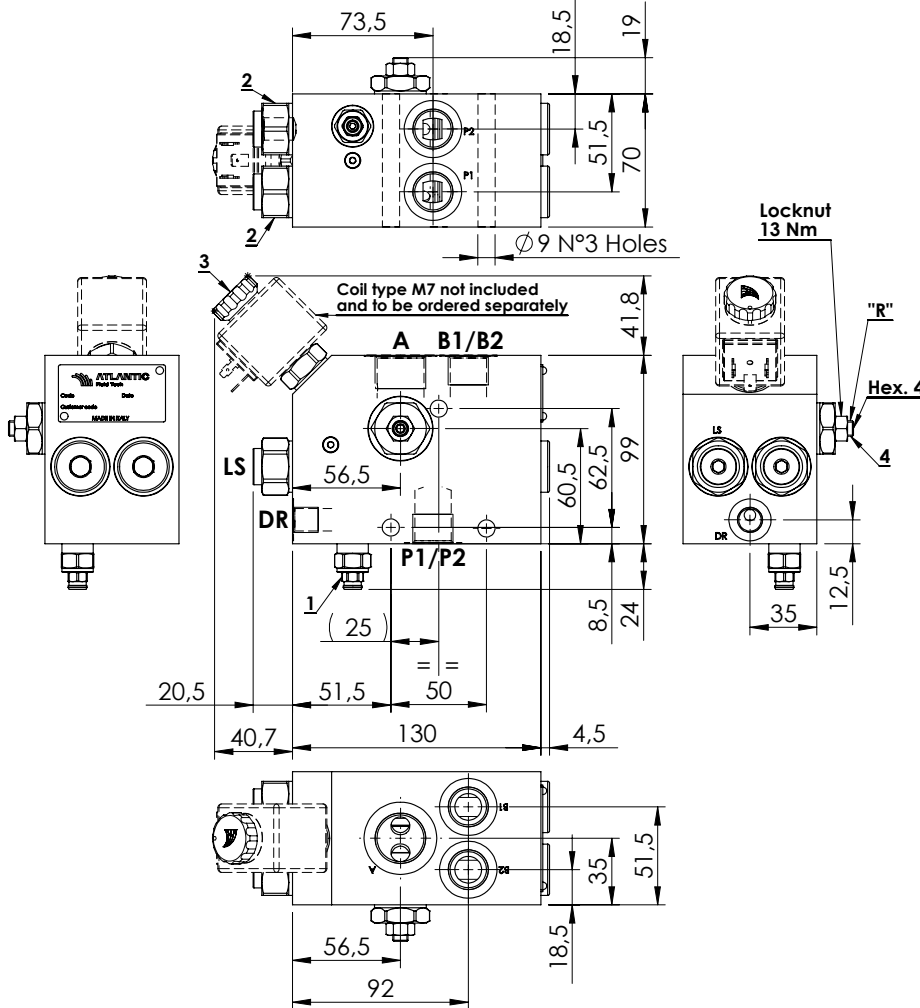
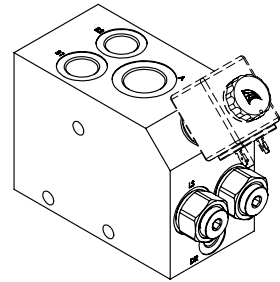

SPECIFICATIONS

Max. operating pressure:	350 bar
Rated flow:	2 x 100 l/min
Regulated Flow:	3 - 150 l/min
Manifold:	Zinc plated steel
Weight:	6,5 kg
Coil:	M7

NOTES

- Turn screw "R" anti-clockwise to increase regulated flow.
- Drain flow when de-energized 2 l/min.
- Max back pressure admitted on "DR" line 1,5 bar.
- For correct operation 8-9 bar must be present in port A. For open centre or low pressure systems a 9 bar check valve should be fitted in port A.
- Spool switching can be influenced by flexing or stressing the valve body. It is recommended to fit spacers on the mounting bolts between the valve and the mounting surface.
- See chapter four for suitable check valves.

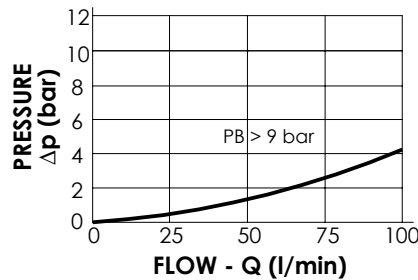
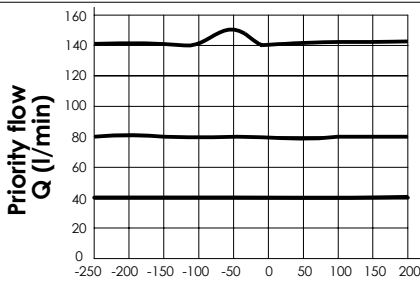

ORDERING CODES

Quick code	Description	Main ports size	Setting range (bar)	Standard setting (bar)	Adjustment (bar/turn)
MF000066	MFTT-100-MHAR-85-G12-N210	P1-P2-B1-B2: G 1/2" A: G3/4"; DR: G 1/4"	100 - 200	200	75
MF000067	MFTT-100-MHAR-85-G12-N350	P1-P2-B1-B2: G 1/2" A: G3/4"; DR: G 1/4"	150 - 350	350	165

FLOW REGULATOR

MFTT-200-MHAR

PRESSURE COMPENSATED PRIORITY
TWO PUMPS SYSTEM
FLOW REGULATOR FOR
AUXILIARY CIRCUITS

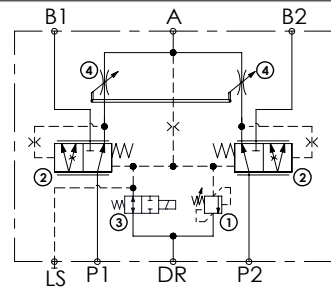
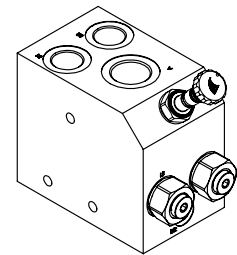
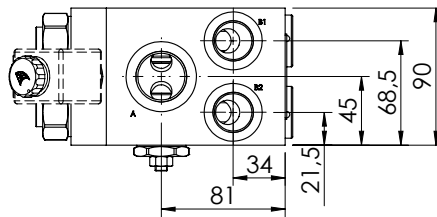
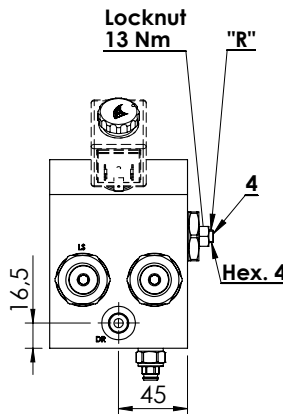
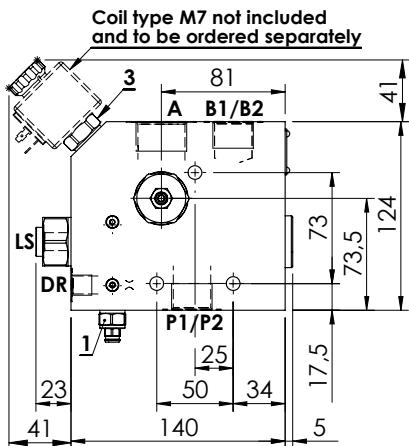
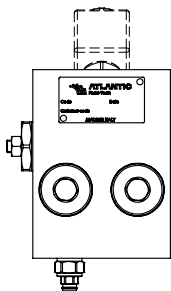
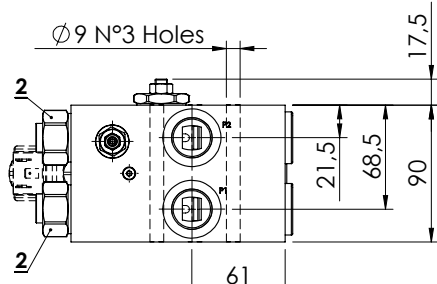

SPECIFICATIONS

Max. operating pressure:	350 bar
Rated flow:	2 x 200 l/min
Regulated Flow:	3 - 250 l/min
Manifold:	Zinc plated steel
Weight:	10,9 kg
Coil:	M7

NOTES

- Turn screw "R" anti-clockwise to increase regulated flow.
- Drain flow when de-energized 2 l/min.
- Max back pressure admitted on "DR" line 1,5 bar.
- For correct operation 8-9 bar must be present in port A. For open centre or low pressure systems a 9 bar check valve should be fitted in port A .
- Spool switching can be influenced by flexing or stressing the valve body. It is recommended to fit spacers on the mounting bolts between the valve and the mounting surface.
- See chapter four for suitable check valves.

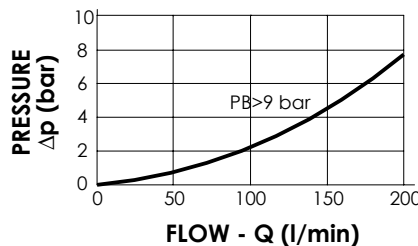
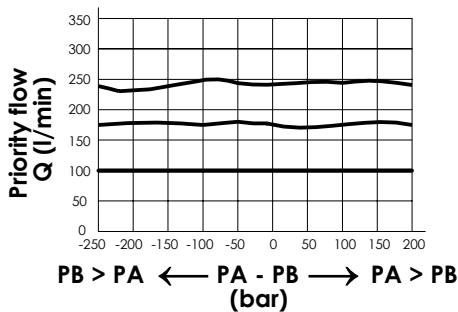

ORDERING CODES

Quick code	Description	Main ports size	Setting range (bar)	Standard setting (bar)	Adjustment (bar/turn)
MF000064	MFTT-200-MHAR-14-G34-N210	P1-P2-B1-B2: G3/4" A: G1"; T: G1/4"	100-200	200	75
MF000065	MFTT-200-MHAR-14-G34-N350	P1-P2-B1-B2: G3/4" A: G1"; T: G1/4"	150-350	350	165

FLOW REGULATOR

MFTT-300-MHAR

**PRESSURE COMPENSATED PRIORITY
TWO PUMPS SYSTEM
FLOW REGULATOR FOR
AUXILIARY CIRCUITS**

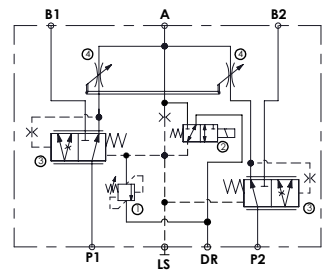
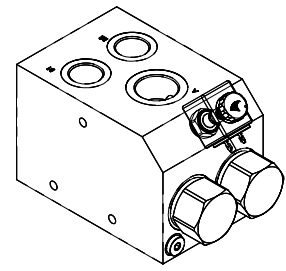
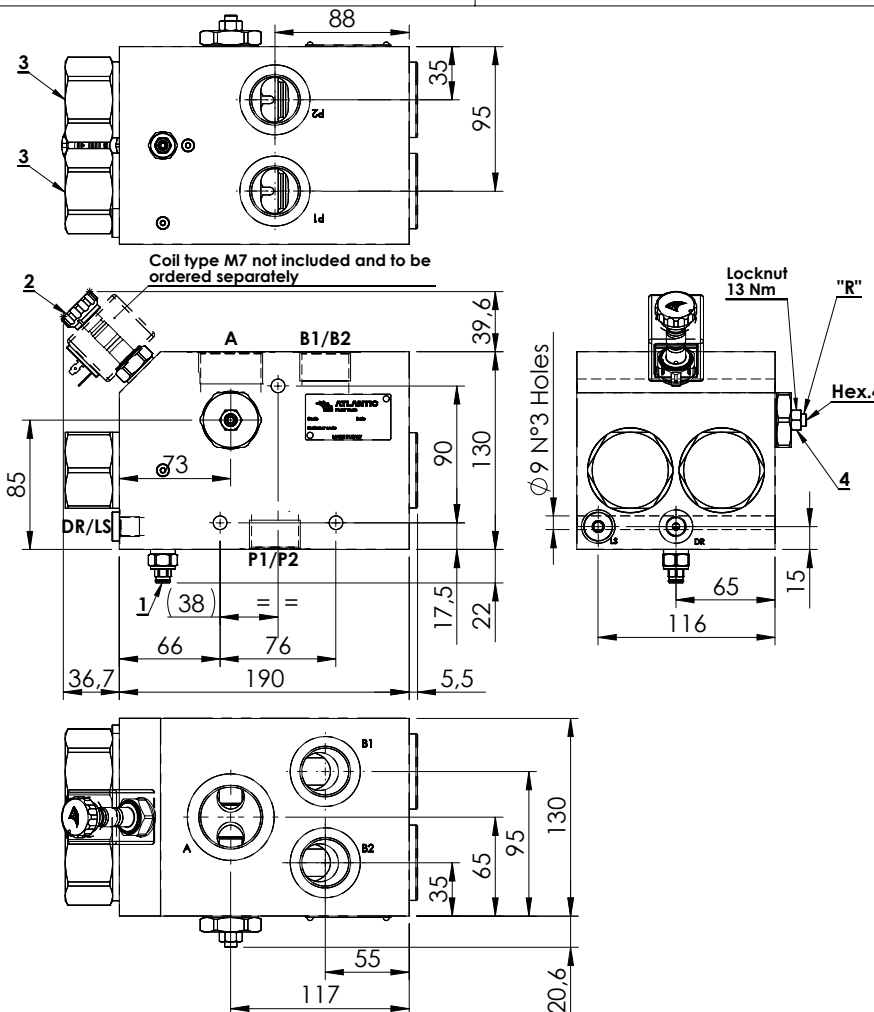

SPECIFICATIONS

Max. operating pressure:	350 bar
Rated flow:	2 x 300 l/min
Regulated Flow:	1,5 - 300 l/min
Manifold:	Zinc plated steel
Weight:	22,36 kg
Coil:	M7

NOTES

- Turn screw "R" anti-clockwise to increase regulated flow.
- Drain flow when de-energized 2 l/min.
- Max back pressure admitted on "DR" line 1,5 bar.
- For correct operation 8-9 bar must be present in port A. For open centre or low pressure systems a 9 bar check valve should be fitted in port A .
- Spool switching can be influenced by flexing or stressing the valve body. It is recommended to fit spacers on the mounting bolts between the valve and the mounting surface.
- See chapter four for suitable check valves.

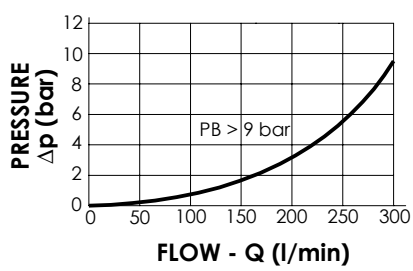
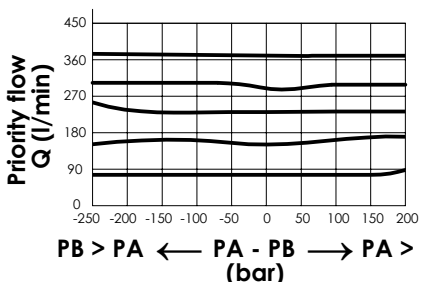

ORDERING CODES

Quick code	Description	Main ports size	Setting range (bar)	Standard setting (bar)	Adjustment (bar/turn)
MF000275	MFTT-300-MHAR-30-G11-N350	P1,P2,B1,B2: G 1" A: G 1-1/4" DR,LS: G 1/4"	120-350	350	165

FLOW REGULATOR

MFCZ-040-LSLR

**PROPORTIONAL VALVE
COMPENSATED**

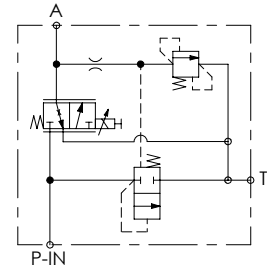
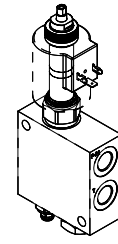
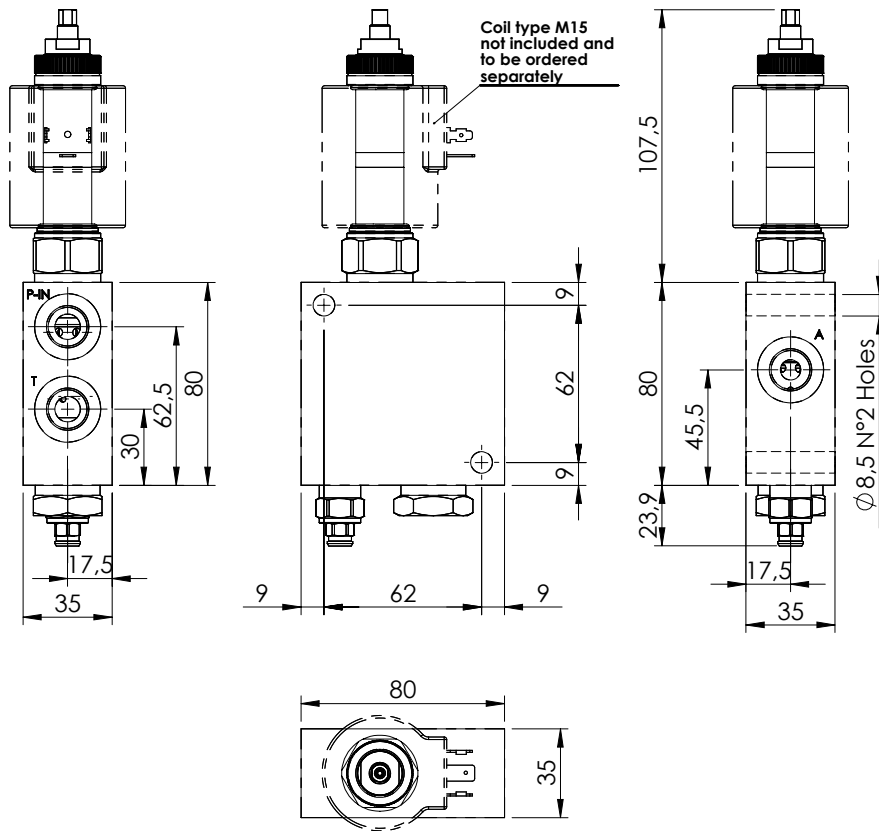

SPECIFICATIONS

Max. operating pressure:	210 bar
Rated flow:	40 l/min
Recommended PWM range:	150-180 Hz
Weight:	0,84 kg
Manifold:	Aluminium
Coil type:	M15
Max. int. leakage:	150 cm ³ /min (@46 cst)

NOTES

- Bleed air before use
- Manual override screw type
- See chapter 18.00.000 for coil.

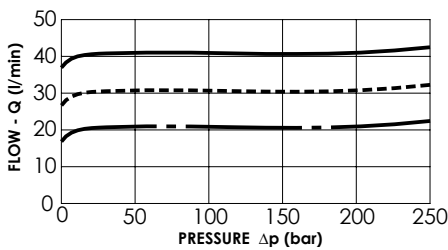

MF000294 3>2———

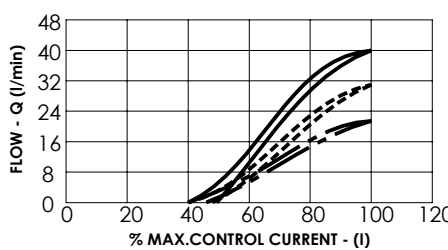

MF000296 3>2—— - - -

ORDERING CODES

Quick code	Description	Rated flow (l/min)	Ports	Threshold current (with 12VDC coil)	Max control current (with 12V DC coil)
MF000294	MFCZ-040-LSLR-40-G38-N210	40	G 3/8"	800 mA (+/-7%)	1600 mA (+/-7%)
MF000295	MFCZ-030-LSLR-30-G38-N210	30	G 3/8"	700 mA (+/-7%)	1500 mA (+/-7%)
MF000296	MFCZ-020-LSLR-20-G38-N210	20	G 3/8"	700 mA (+/-7%)	2400 mA (+/-7%)

FLOW REGULATOR

MFPC-140-AMLR

PROPORTIONAL VALVES WITH ANTICAVITATION

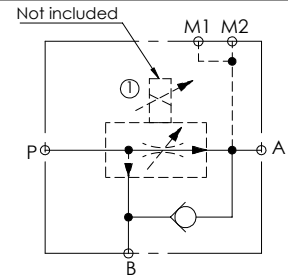
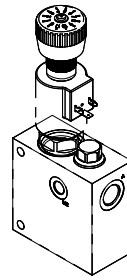
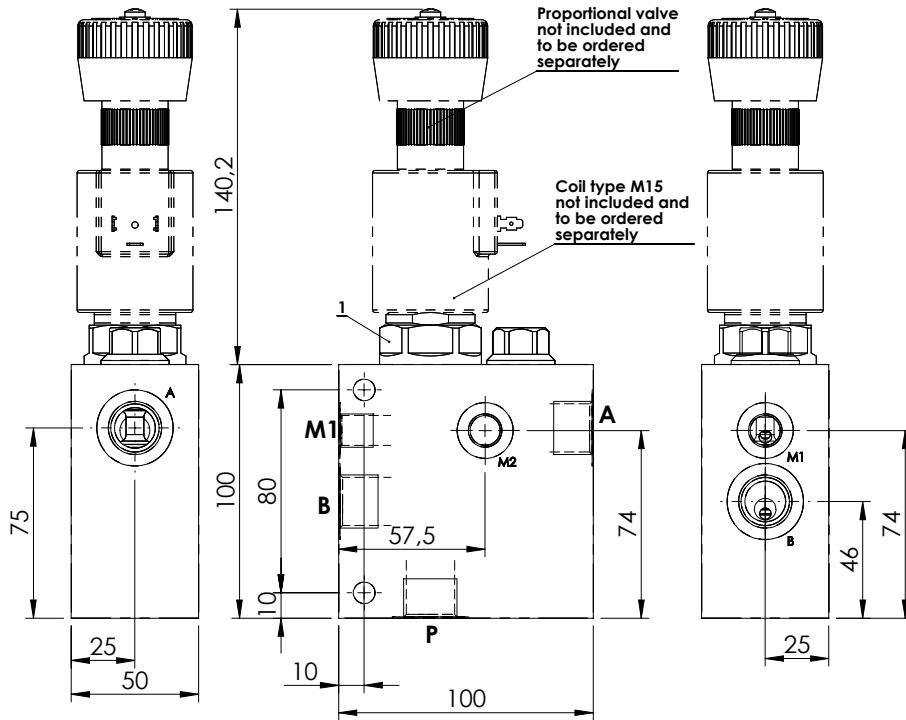
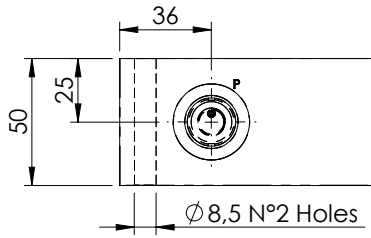

SPECIFICATIONS

Max. operating pressure:	320 bar
Rated flow:	140 l/min
Max regulated flow:	0 - 80 l/min
Manifold:	Aluminium
Weight:	1,1 kg
Coil type:	M15
Cavity type:	SAE-16-3N

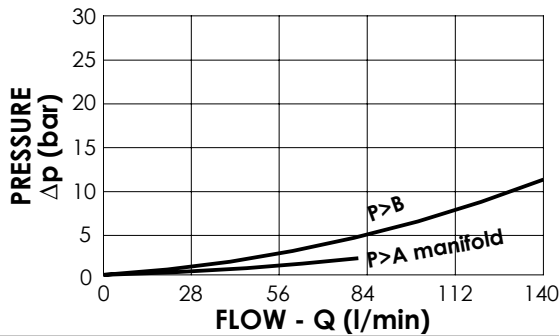

NOTES

- See chapter 18.00.000 for coil.
- See chapter 16.00.000 for proportional valve info.

ORDERING CODES

Quick code	Description	Main ports size	Standard setting (bar, Q=5 l/min)	Adjust. range (bar)	Pressure increase (bar/turn)
MF000349	MFPC-140-AMLR-80-G12-N320	P,A,T: G1/2" M: G1/4"	200	60-210	24

FLOW REGULATOR

MFPC-140-LMLR

PROPORTIONAL VALVE WITH RELIEF

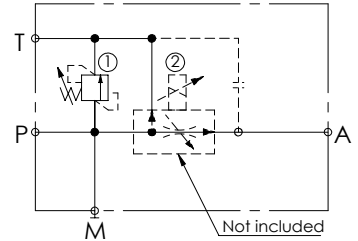
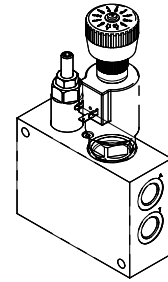
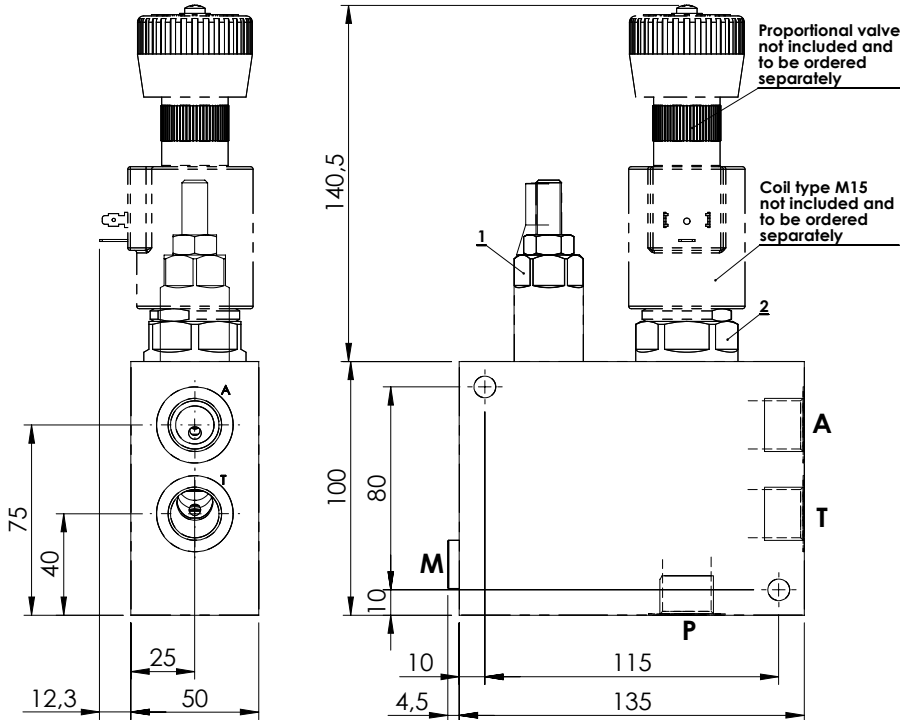
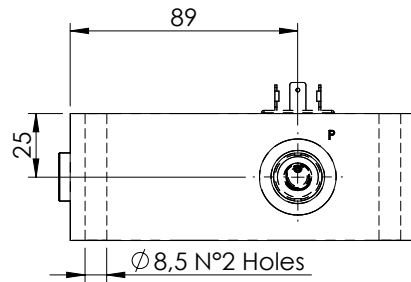

SPECIFICATIONS

Max. operating pressure:	320 bar
Rated flow:	140 l/min
Max regulated flow:	0 - 80 l/min
Manifold:	Aluminium
Weight:	1,7 kg
Coil type:	M15
Cavity type:	SAE-16-3N

SEALING CAP

Ordering code:
AT000021



NOTES

- See chapter 18.00.000 for coil.
- See chapter 16.00.000 for proportional valve info.

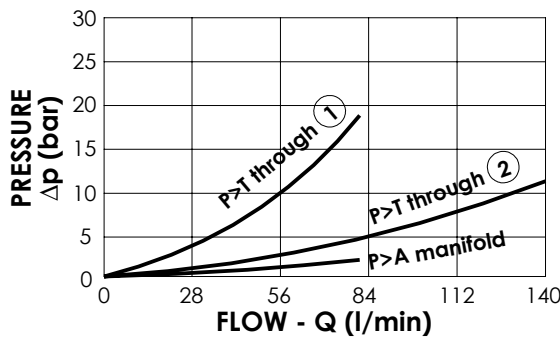

ORDERING CODES

Quick code	Description	Main ports size	Standard setting (bar, Q=5 l/min)	Adjust. range (bar)	Pressure increase (bar/turn)
MF000350	MFPC-140-LMLR-80-G12-N320	P,A,T: G1/2" M: G1/4"	200	60-210	24

FLOW REGULATOR

MFPC-140-TMLR

**PROPORTIONAL VALVES
WITH BYPASS CHECK
WITH RELIEF**

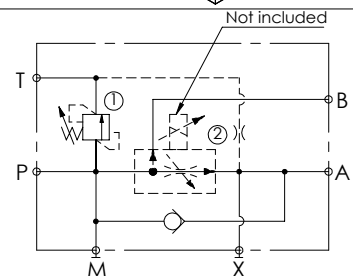
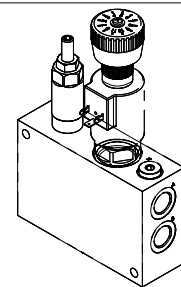
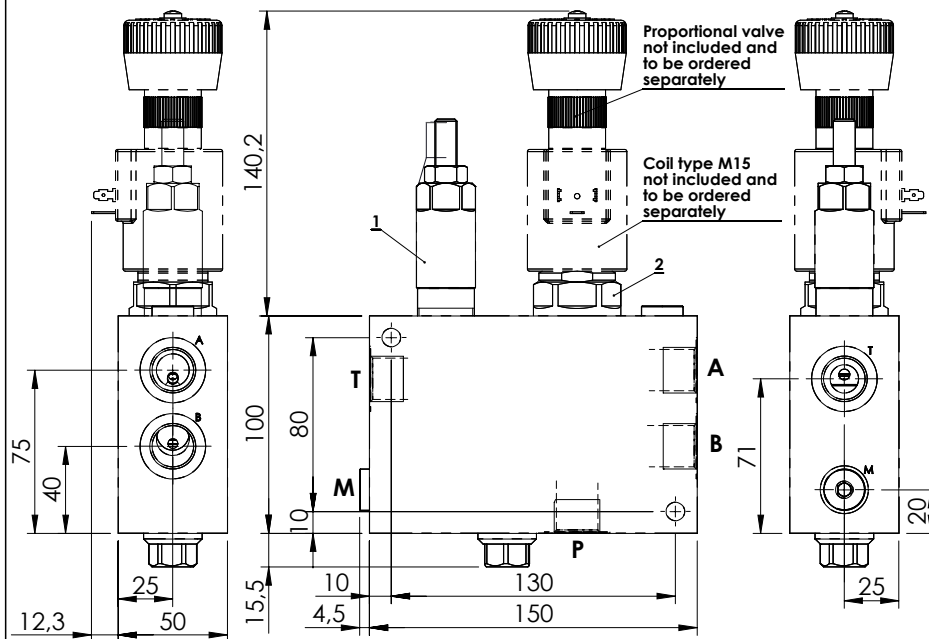
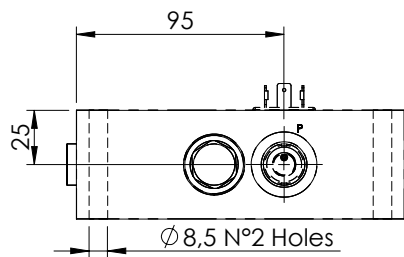

SPECIFICATIONS

Max. operating pressure:	320 bar
Rated flow:	140 l/min
Max regulated flow:	0 - 80 l/min
Manifold:	Aluminium
Weight:	2,0 kg
Coil type:	M15
Cavity type:	SAE-16-3N

SEALING CAP

Ordering code:
AT000021

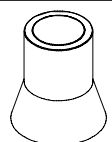

NOTES

- See chapter 18.00.000 for coil.
- See chapter 16.00.000 for proportional valve info.

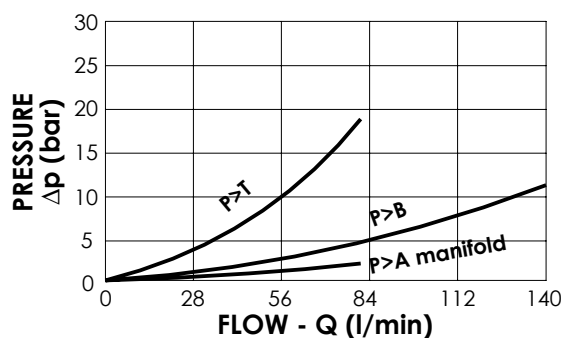

ORDERING CODES

Quick code	Description	Main ports size	Standard setting (bar, Q=5 l/min)	Adjust. range (bar)	Pressure increase (bar/turn)
MF000351	MFPC-140-TMLR-80-G12-N320	P,A,T: G1/2" M: G1/4"	200	60-210	24

FLOW REGULATOR

MFPC-200-MMAR

PROPORTIONAL VALVES WITH UNLOADING WITH RELIEF

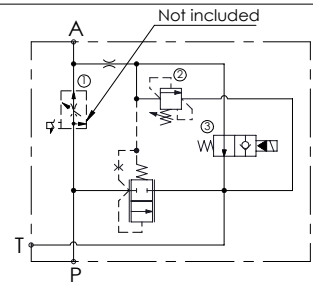
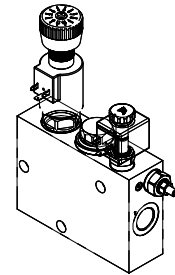
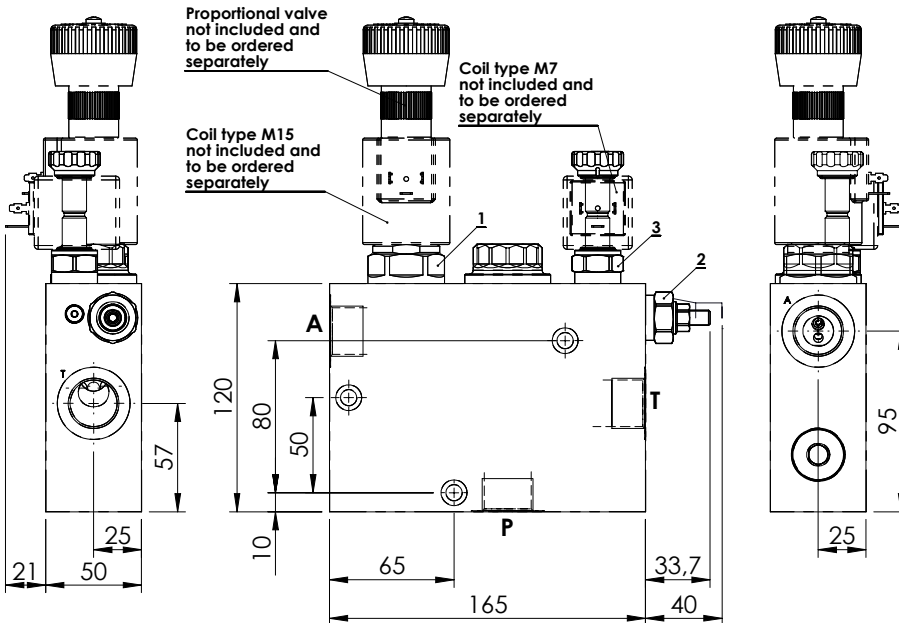
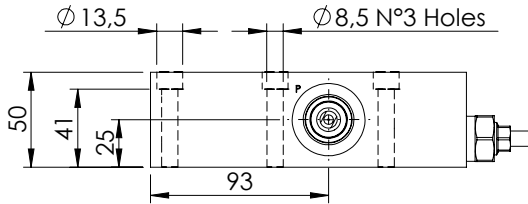

SPECIFICATIONS

Max. operating pressure:	320 bar
Rated flow:	200 l/min
Max regulated flow:	0 - 80 l/min
Manifold:	Zinc plated steel
Weight:	6,72 kg
Coil type:	M7 - M15
Cavity type:	SAE-16-3N

SEALING CAP

Ordering code:
AT000020



NOTES

- See chapter 18.00.000 for coils.
- See chapter 16.00.000 for proportional valve info.

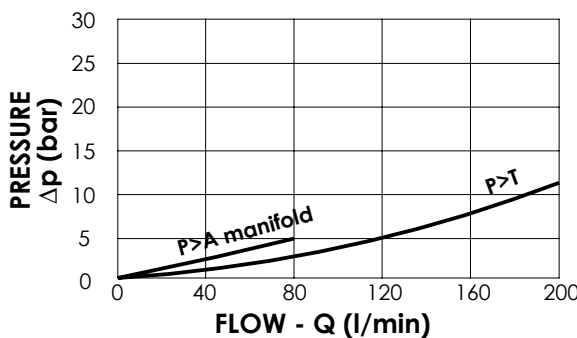

ORDERING CODES

Quick code	Description	Main ports size	Standard setting (bar, Q=5 l/min)	Adjust. range (bar)	Pressure increase (bar/turn)
MF000352	MFPC-200-MMAR-80-G12-N320	P,T,R: G 3/4"	220	140-350	142



ATLANTIC
Fluid Tech

SECTION 14

Special
Valves



1800-OILSOL
1800-645765

<https://oilsolutions.com.au/>

sales@oilsolutions.com.au

SECTION 14**SPECIAL VALVES**

Chapter	Valve type	Page
14. 1	Fan drive blocks	14.01.000
14. 2	Differential lock valves	14.02.000
14. 3	Unloading - Inloading valves	14.03.000
14. 4	Filter blocks	14.04.000
14. 5	End of stroke valves	14.05.000
14. 6	Pilot blocks	14.06.000
14. 7	Automatic Switching Valves	14.07.000
14. 8	Load Limiting Device	14.08.000



1800-OILSOL
1800-645765

<https://oilsolutions.com.au/>

sales@oilsolutions.com.au

SECTION 14. 1

SPECIAL VALVES - FAN DRIVE BLOCKS



Hydraulic scheme	Valve description	Valve type	Rated flow (l/min)	Max. pressure (bar)	Installation	Main port size or cavity type	Page
	BNN-045-GEC	With proportional pressure control	45	320	In line	G 1/2"	14.01.010

FAN DRIVE BLOCKS

BNND-045-GEC

PROPORTIONAL
PRESSURE CONTROL
WITH INVERSION

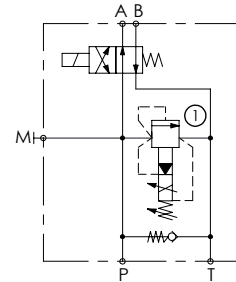
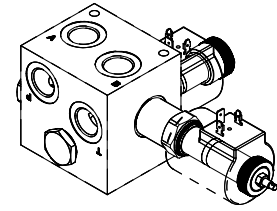
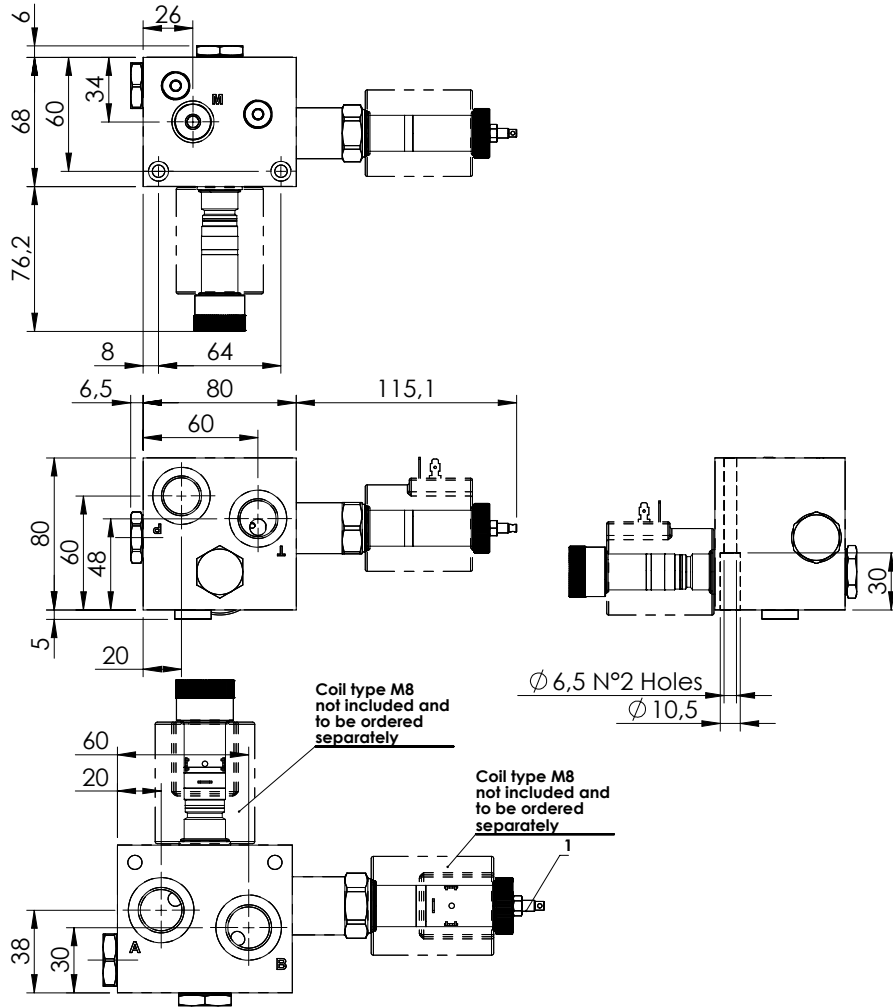

SPECIFICATIONS

Max. operating pressure:	320 bar
Rated flow:	45 l/min
Manifold:	Cast Iron
Weight:	3,28 kg
Coil:	M8

NOTES

- When valve ① is energized the pressure lowers from the setting to.
- See chapter 18.00.000 for coil.

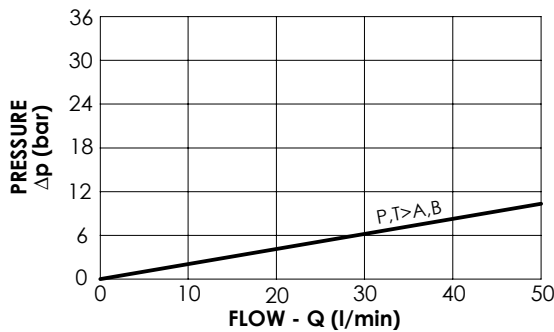

ORDERING CODES

Quick code	Description	Main ports size	Standard setting (bar)	Setting range (bar)
BD000198	BNND-045-GEC-NP-G12-N320	P,T,A,B:G1/2" M:G1/4"	210	100-320

SECTION 14. 2

SPECIAL VALVES - DIFFERENTIAL LOCK VALVES



Hydraulic scheme	Valve description	Valve type	Rated flow (l/min)	Max. pressure (bar)	Installation	Main port size or cavity type	Page
	MFDT-150-BFAR-55	With electric bypass	150	350	In line	G 1/2"	14.02.010
	MFDT-150-BFAR-95	With electric bypass	150	350	In line	G 1/2"	14.02.010
	BNND-200-AED	With electric bypass for three motors transmission	200	500	In line	G 3/4"	14.02.020

DIFFERENTIAL LOCK VALVE

MFDT-150-BFAR

WITH ELECTRIC BYPASS

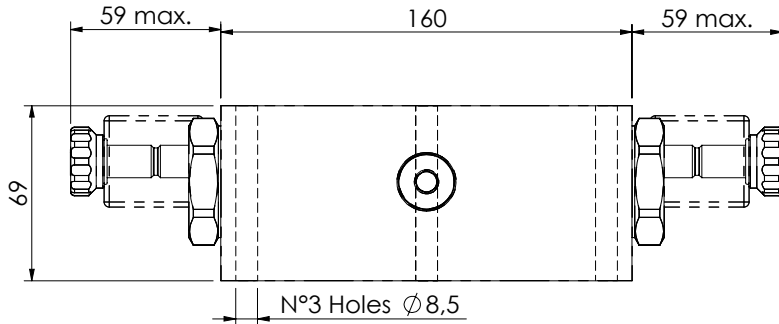

Coil type M7 not included and to be ordered separately

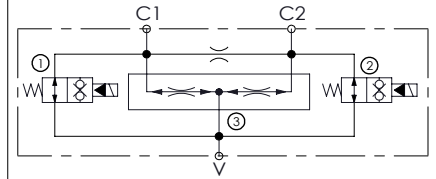
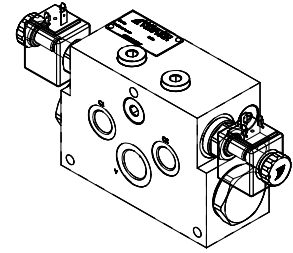
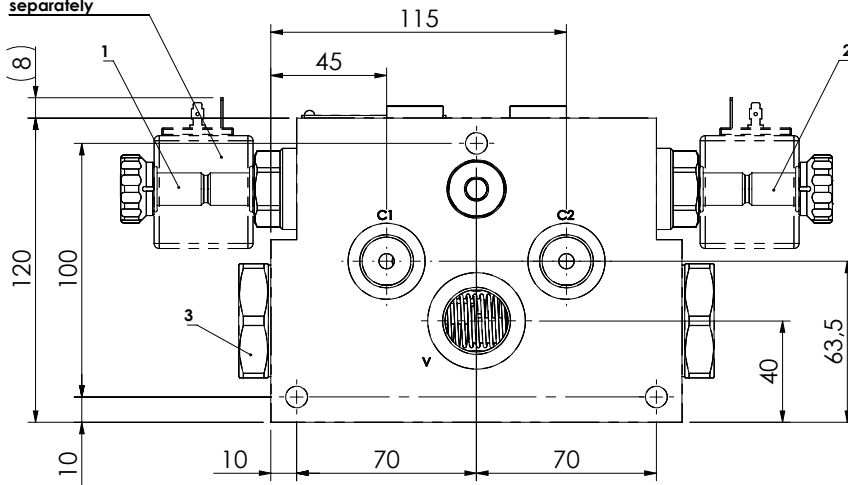

SPECIFICATIONS

Max. operating pressure:	350 bar
Rated flow:	150 l/min
Regulated Flow:	See table
Manifold:	Steel
Weight:	9 kg
Coil:	M7

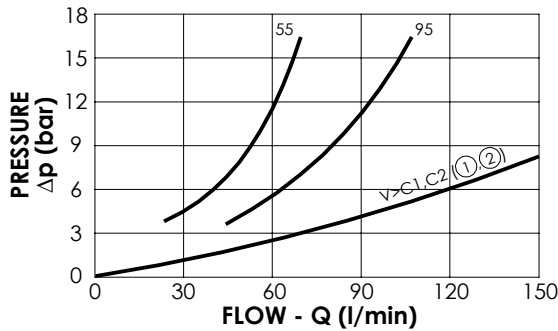

NOTES

- For other flow ranges contact AFT sales network.
- See chapter 18.00.000 for coil.

ORDERING CODES

Quick code	Description	Main ports size	Regulated flow range (l/min)
MF000347	MFDT-150-BFAR-55-G34-N350	C1,C2: G1/2" V: G3/4"	28-55
MF000348	MFDT-150-BFAR-95-G34-N350	C1,C2: G1/2" V: G3/4"	56-95

DIFFERENTIAL LOCK VALVE

BNND-200-AED

WITH ELECTRIC BYPASS FOR THREE MOTORS TRANSMISSION

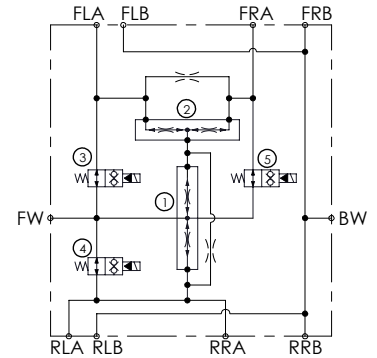
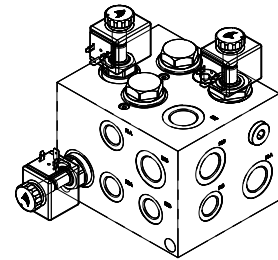
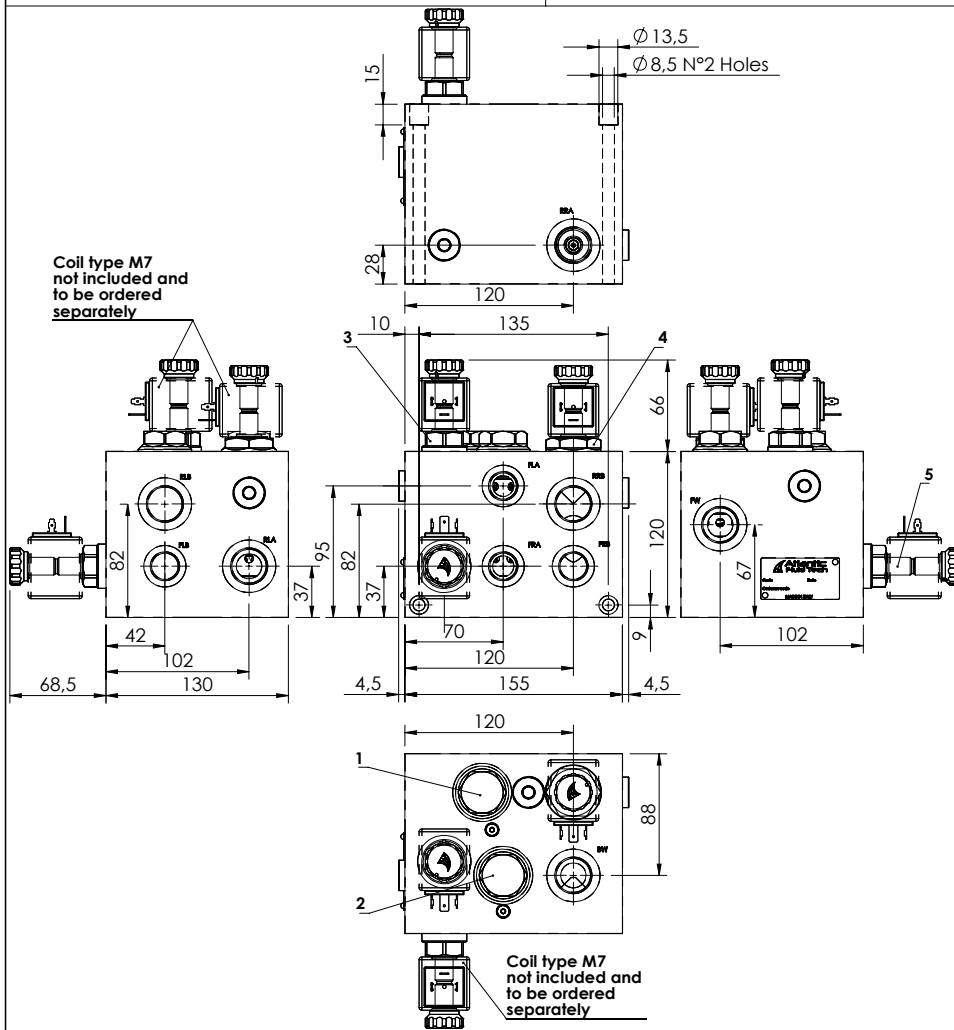

SPECIFICATIONS

Max. operating pressure:	500 bar
Rated flow:	200 l/min
Manifold:	Steel
Weight:	16,7 kg
Coil:	M7

NOTES

-For other flow ranges contact AFT sales network
 -See chapter 18.00.000 for coil.

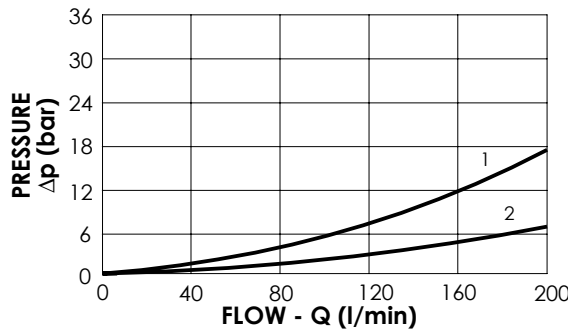

- 1: FW>FxA, RxA
① ②
- 2: FW>FxA, RxA
③ ④

ORDERING CODES

Quick code	Description	Main ports size	Flow diverter ratio:	Inlet range flow (l/min)
BD000199	BNND-200-AED-NP-G34-N500	FW,BW,RLA,RLB,RRA,RRB:G 3/4" FLA,FLB,FRA,FRB:G 1/2"	① 50%-50% ② 33%-66%	48 - 170



1800-OILSOL
1800-645765

<https://oilsolutions.com.au/>

sales@oilsolutions.com.au

SECTION 14. 3

SPECIAL VALVES - UNLOADING/INLOADING VALVES



Hydraulic scheme	Valve description	Valve type	Rated flow (l/min)	Max. pressure (bar)	Installation	Main port size or cavity type	Page
	MTP-120-TLSN MTP-200-TLSN MTP-250-TLSN	Spool type, pump unloading, piloted Spool type, pump unloading, piloted Spool type, pump unloading, piloted	120 200 250	210 210 210	In line In line In line	G 1/2" G 3/4" G 1"	14.03.010 14.03.010 14.03.010
	MFTS-200-DHAN MFTS-200-DHAN MFTS-200-DHAN	Solenoid operated unloading valve, with relief Solenoid operated unloading valve, with relief Solenoid operated unloading valve, with relief	200 200 200	250 250 350	In line In line In line	G 3/4" G 1" G 1"	14.03.020 14.03.030 14.03.040
	BNND-040-LE		40	210	In line	G 1/2"	14.03.050
	MTTE-150-SLSN	Solenoid operated unloading valve, piloted	150	350	In line	1 1/16"-15 UNF	14.03.060
	MTSB-150-SDSN	For Cetop 5	150	350	Flanged	Cetop 5	14.03.070
	MFTS-150-EFCE		150	350	In line	1 1/16"-12 UNF	14.03.080
	MTSD-150-TLSN		150	300	In line	G 3/4"	14.03.090

UNLOADING VALVE

MTP-XXX-XLSN

**PUMP UNLOADING
PILOTED**

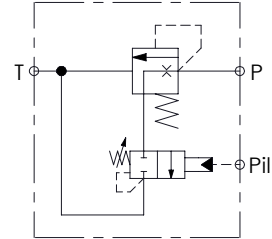
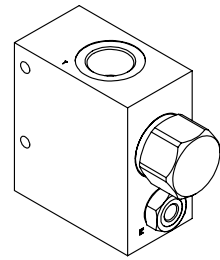
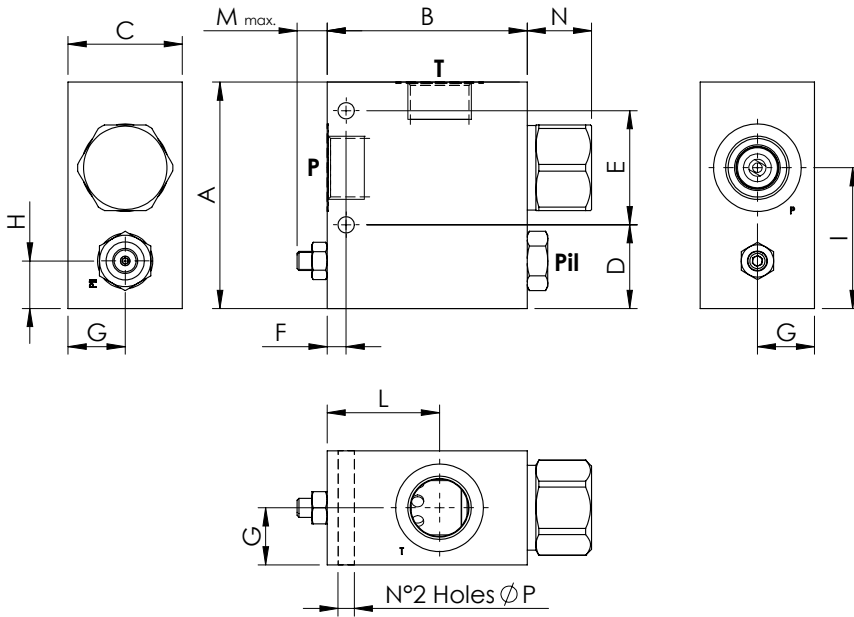

SPECIFICATIONS

Max. operating pressure:	210/350 bar
Rated flow:	See table
Manifold:	See table
Weight:	Aluminium 2,49 kg; Steel 5,7 kg

A	B	C	D	E	F	G	H	I	L	M	N	P	CODE
119	105	60	44	60	10	30	25	74	59	15	33,8	8,5	MT000007 MT000022
105	100	40	35	45	15	20	16	56	52	19,5	18,8	8,5	MT000015
90	100	40	35	45	15	20	16	56	52	19,5	18,8	8,5	MT000014

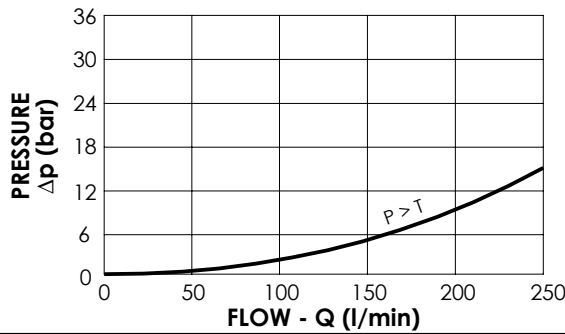

ORDERING CODES

Quick code	Description	Manifold material	Main ports size	Nominal flow (l/min)	Standard setting (bar, Q=5 l/min)	Adjust. range (bar)	Pressure increase (bar/turn)
MT000007	MTP-250-TLSN-NP-G10-N210	Aluminium	P,T:G 1" Pil:G 1/4"	250	200	70 -210	49
MT000015	MTP-200-TLSN-NP-G34-N210	Aluminium	P,T:G 3/4" Pil:G 1/4"	200	200	70 -210	49
MT000014	MTP-120-TLSN-NP-G12-N210	Aluminium	P,T:G 1/2" Pil:G 1/4"	120	130	70 -210	49
MT000022	MTP-250-SLSN-NP-G10-N350	Steel	P,T:G 1" Pil:G 1/4"	250	200	70 -210	49

UNLOADING VALVE

MFTS-200-DHAN

**SOLENOID OPERATED
UNLOADING VALVE
WITH RELIEF**

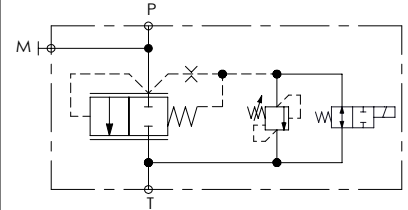
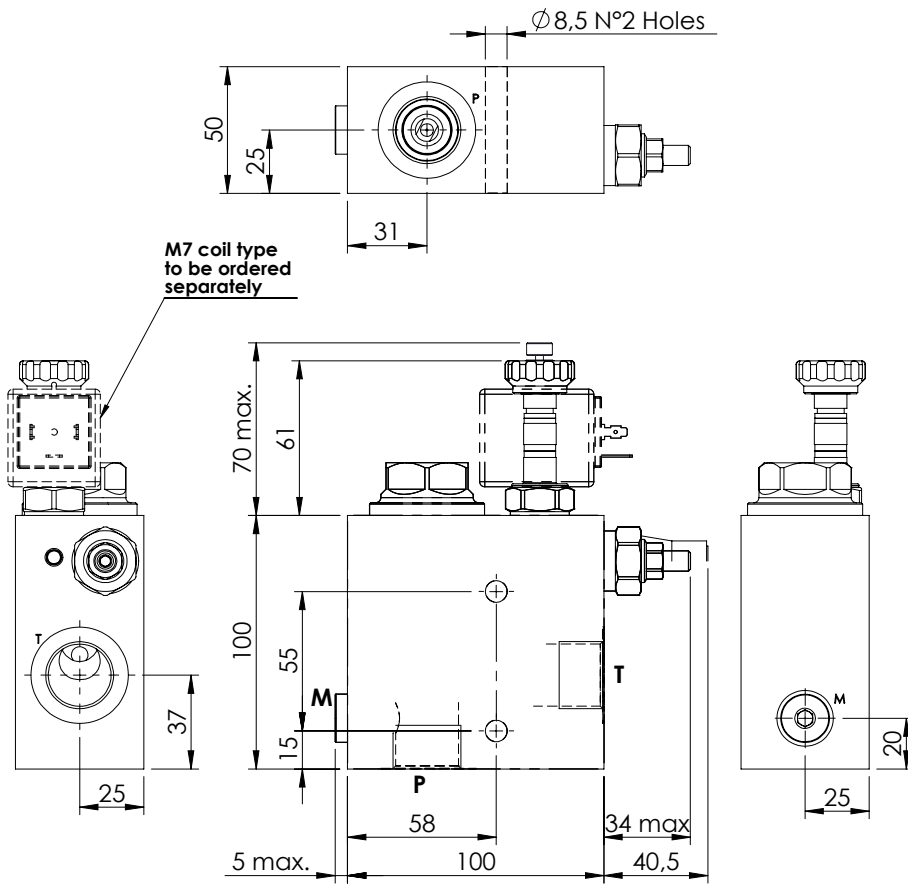
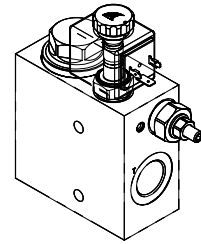

SPECIFICATIONS

Max. operating pressure:	250 bar
Rated flow:	200 l/min
Manifold:	Aluminium
Weight:	1,69 kg
Coil type:	M7

SEALING CAP

Ordering code:
AT000020

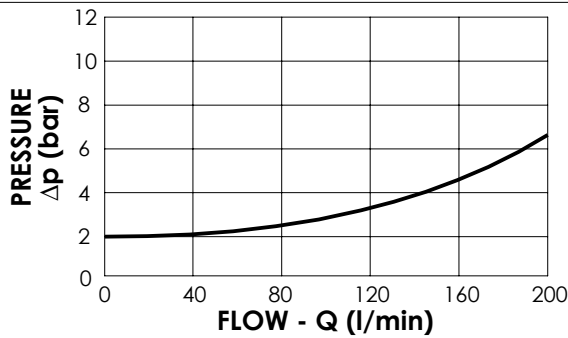
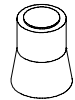

NOTES

Internal leakage: 80 cc/min
Available in steel version for 350 bar maximum operating pressure
See chapter 18.00.000 for coil.

OPTIONS



Standard



Push style override

ORDERING CODES

Quick code	Description	Ports size	Standard setting (bar, Q=5 l/min)	Adjust. range (bar)	Pressure increase (bar/turn)	Options
MF000038	MFTS-200-DHAN-NP-G34-N250	P,T:G 3/4" M:G 1/4"	200	140-350	142	Standard
MF000044	MFTS-200-DHAE-NP-G34-N250	P,T:G 3/4" M:G 1/4"	200	140-350	142	Push style override

UNLOADING VALVE

MFTS-200-DHAN

**SOLENOID OPERATED
UNLOADING VALVE
WITH RELIEF**

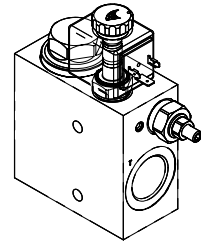
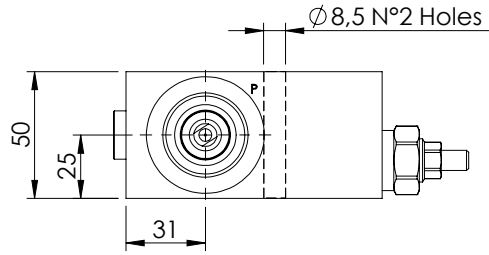

M7 coil type to be ordered separately

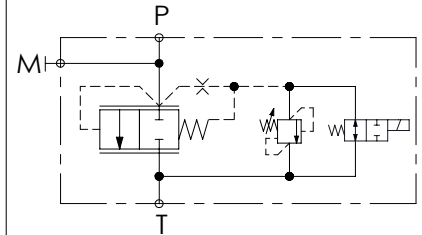
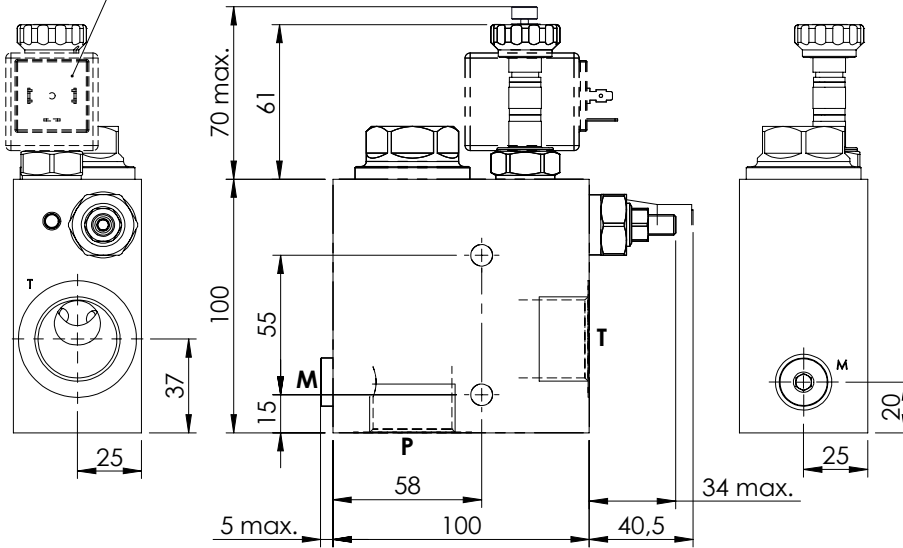

SPECIFICATIONS

Max. operating pressure:	250 bar
Rated flow:	200 l/min
Manifold:	Aluminium
Weight:	1,65 kg
Coil type:	M7

SEALING CAP

Ordering code:
AT000020

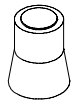

NOTES

Internal leakage: 80 cc/min
Available in steel version for 350 bar maximum operating pressure
See chapter 18.00.000 for coil.

OPTIONS



Standard



Push style override

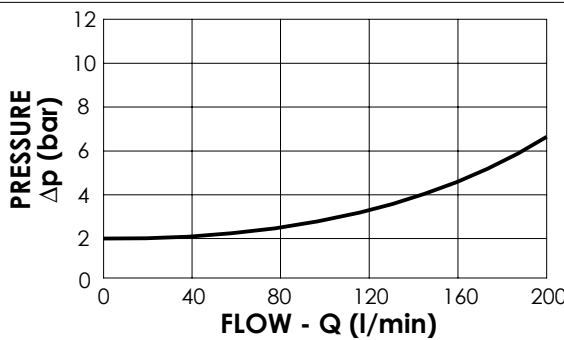

ORDERING CODES

Quick code	Description	Ports size	Standard setting (bar, Q=5 l/min)	Adjust. range (bar)	Pressure increase (bar/turn)	Options
MF000039	MFTS-200-DHAN-NP-G10-N250	P,T:G 1" M:G 1/4"	200	140-350	142	Standard
MF000043	MFTS-200-DHAE-NP-G10-N250	P,T:G 1" M:G 1/4"	200	140-350	142	Push style override

UNLOADING VALVE

MFTS-200-DHAN

**SOLENOID OPERATED
UNLOADING VALVE
WITH RELIEF**

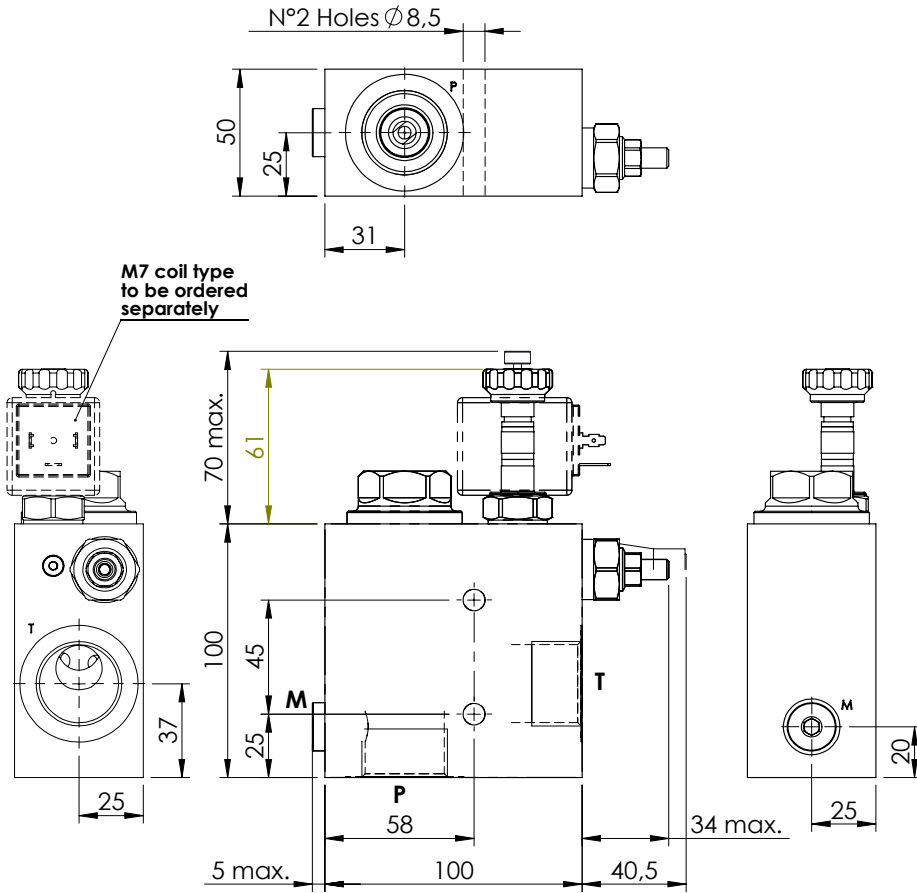
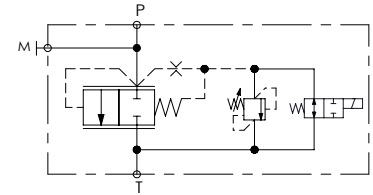
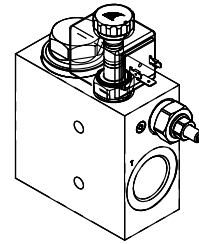

M7 coil type to be ordered separately

SPECIFICATIONS

Max. operating pressure:	350 bar
Rated flow:	200 l/min
Manifold:	Steel
Weight:	3,57 kg

SEALING CAP

Ordering code:
AT000020

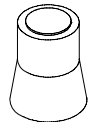

NOTES

See chapter 18.00.000 for coil.

OPTIONS

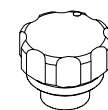

Standard

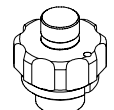

Push style override

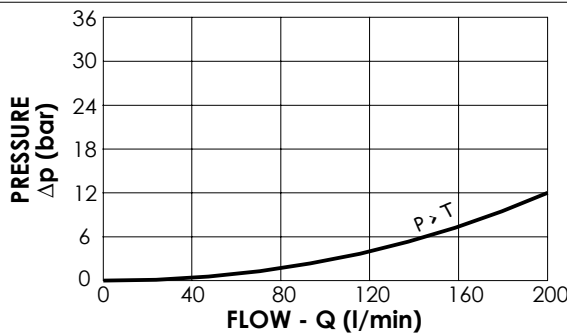

ORDERING CODES

Quick code	Description	Ports size	Standard setting (bar, Q=5 l/min)	Adjust. range (bar)	Pressure increase (bar/turn)	Options
MF000083	MFTS-200-DHAN-NP-G10-N350	P,T:G 1" M:G 1/4"	350	140-350	142	Standard
MF000103	MFTS-200-DHAE-NP-G10-N350	P,T:G 1" M:G 1/4"	350	140-350	142	Push style override

UNLOADING VALVE

BNND-040-LE

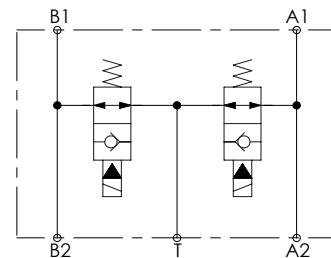
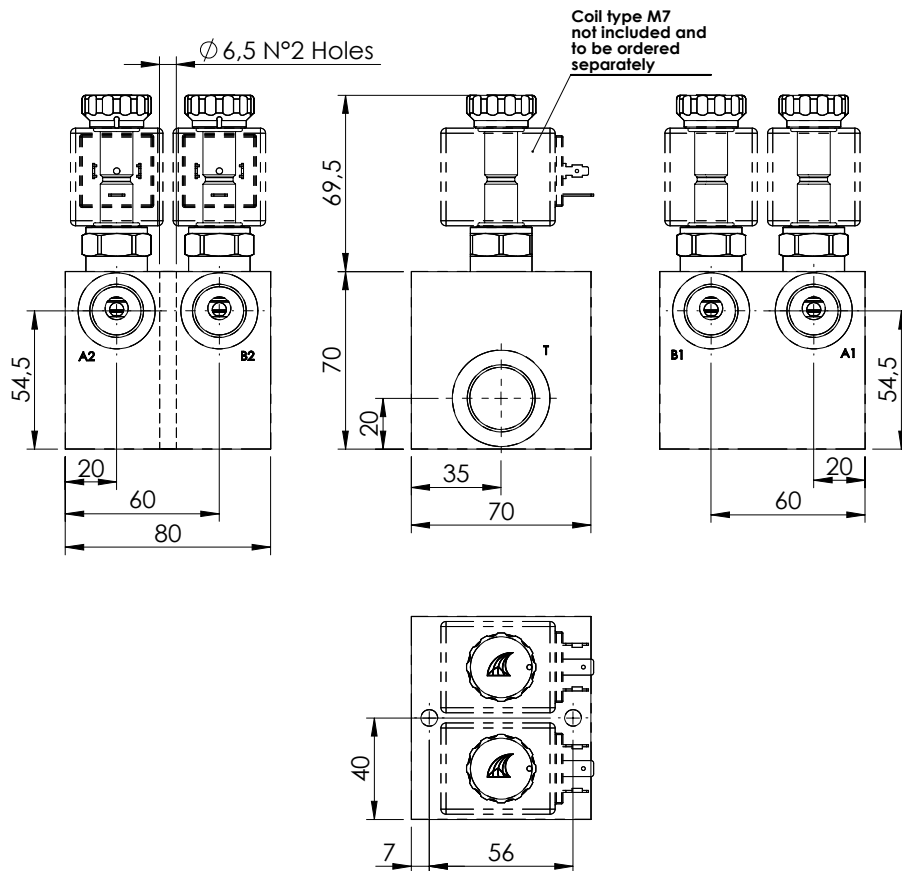
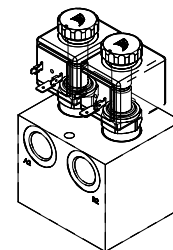

SPECIFICATIONS

Max. operating pressure:	210 bar
Rated flow:	40 l/min
Manifold:	Aluminium
Weight:	1,1 kg
Coil:	M7

NOTES

See chapter 18.00.000 for coil.

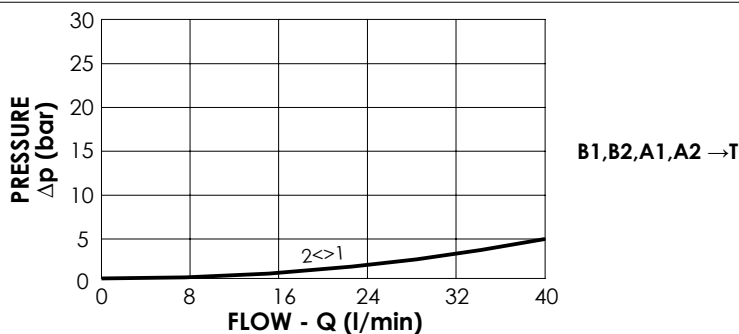

ORDERING CODES

Quick code	Description	Main ports size
BD000200	BNND-040-LE-NP-G12-N210	A1,A2,B1,B2: G1/2" T: G3/4"

UNLOADING VALVE

MTTE-150-SLSN

PUMP UNLOADING PILOTED

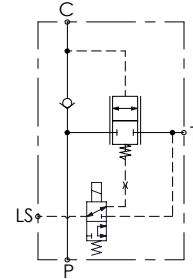
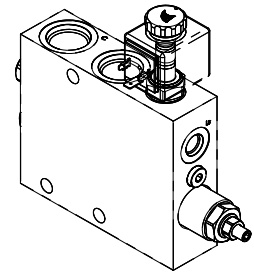
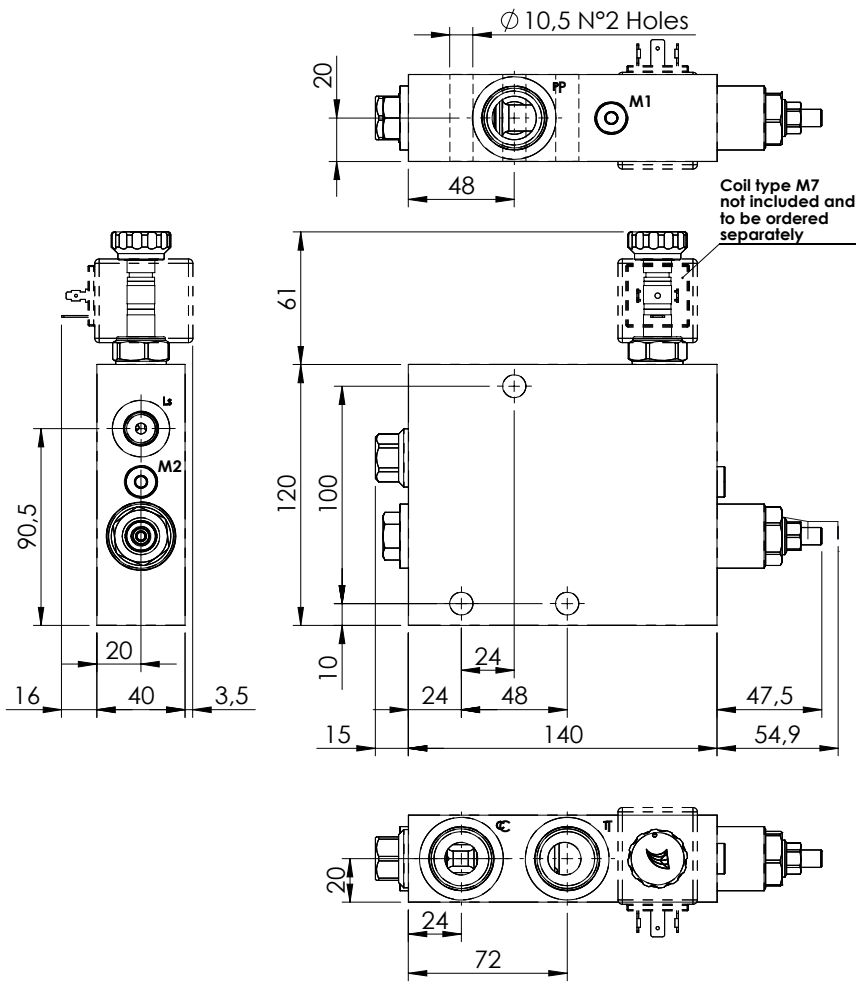

SPECIFICATIONS

Max. operating pressure:	350 bar
Rated flow:	150 l/min
Manifold:	Steel
Weight:	4,69 Kg
Coil:	M7

SEALING CAP

Ordering code:
AT000020

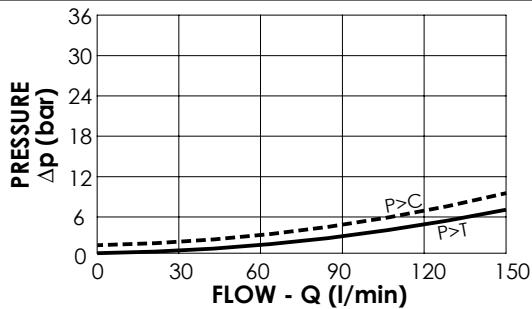
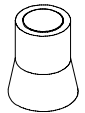

NOTES

See chapter 18.00.000 for coil.

ORDERING CODES

Quick code	Description	Main ports size
MT000028	MTTE-150-SLSN-NP-U11-N350	P,C,T: 1 1/16" UNF-2B LS: 9/16" UNF-2B

UNLOADING VALVE

MTSB-150-SDSN

CETOP 5

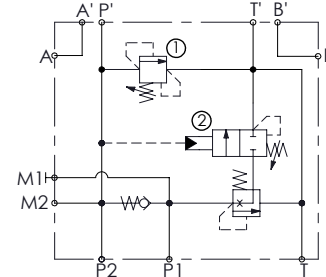
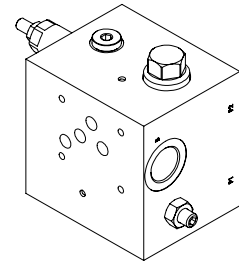
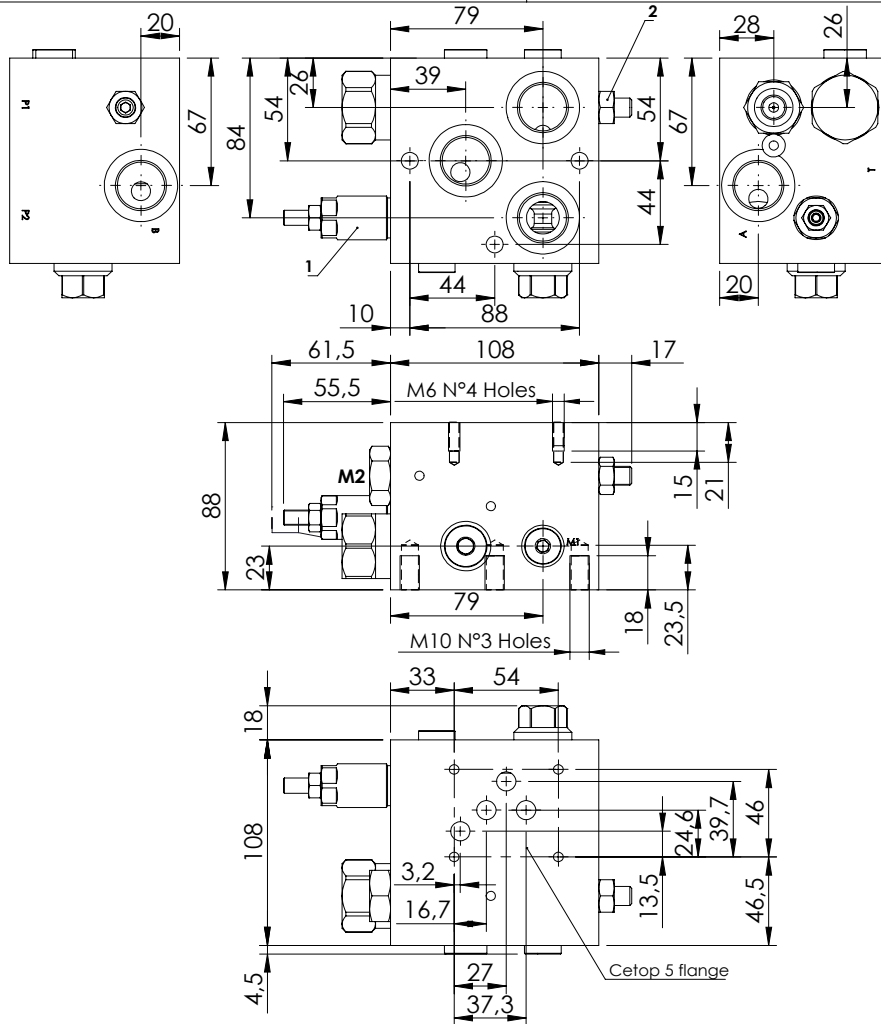

SPECIFICATIONS

Max. operating pressure:	350 bar
Rated flow:	150 l/min
Manifold:	Steel
Weight:	7,25 kg

SEALING CAP

Ordering code:
AT000020

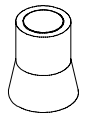

NOTES

P2 > P' : 50 l/min
 P1 > P' : 100 l/min
 Max flow ① : 30 l/min

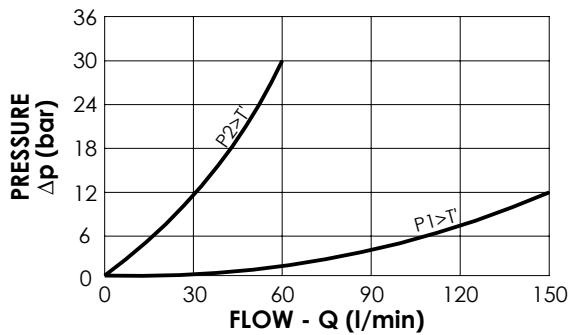

ORDERING CODES

Quick code	Description	Main ports size	Standard setting (bar, Q=5 l/min)	Adjust. range (bar)	Pressure increase (bar/turn)
MT000029	MTSB-150-SDSN-NP-G34-N350	A,B,P1,P2,T: G3/4" A',B',P',T': Cetop 5 M1,M2: G1/4"	① 200 ② 50	① 50-210 ② 20-100	① 42 ② 23

UNLOADING VALVE

MFTS-150-EFCE

SOLENOID OPERATED

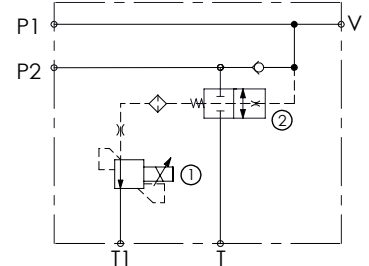
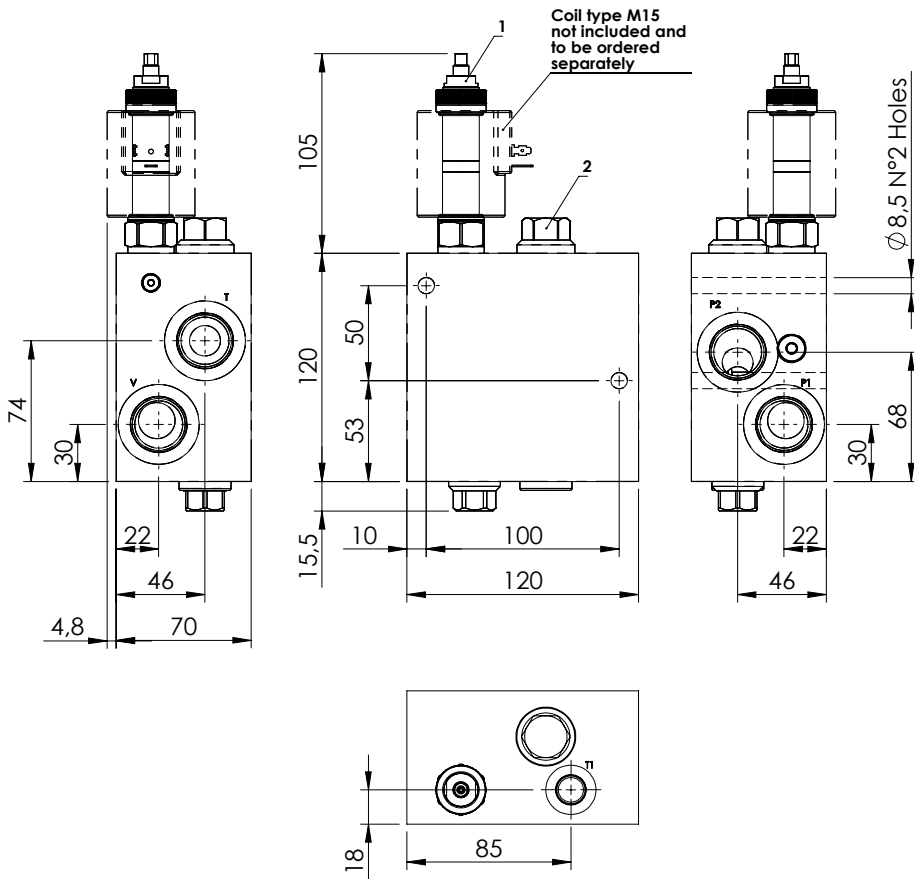
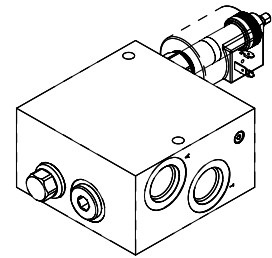

SPECIFICATIONS

Max. operating pressure:	350 bar
Rated flow:	150 l/min
Manifold:	Steel
Weight:	7,1 kg
Coil type:	M5

NOTES

-See chapter 18.00.000 for coil.

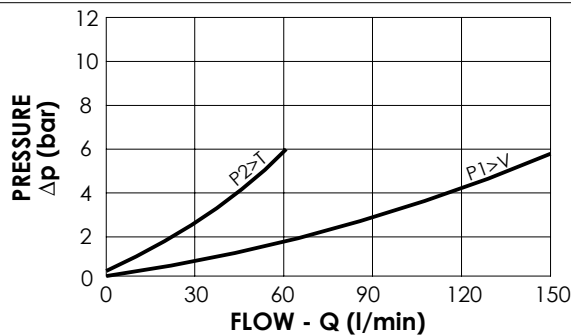

ORDERING CODES

Quick code	Description	Main Ports Size	Standard setting (bar)	Setting range (bar)
MF000345	MFTS-150-EFCE-NP-U11-N350	V,P1,P2,T:1" 1/16-12 UNF T1:9/16-18 UNF	30	30-350

UNLOADING VALVE

MTSD-150-TLSN

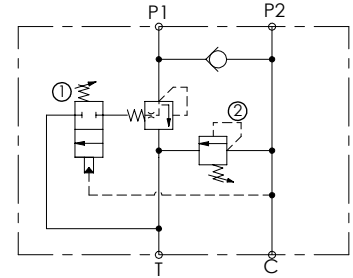
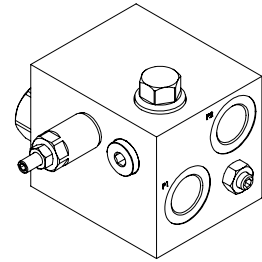
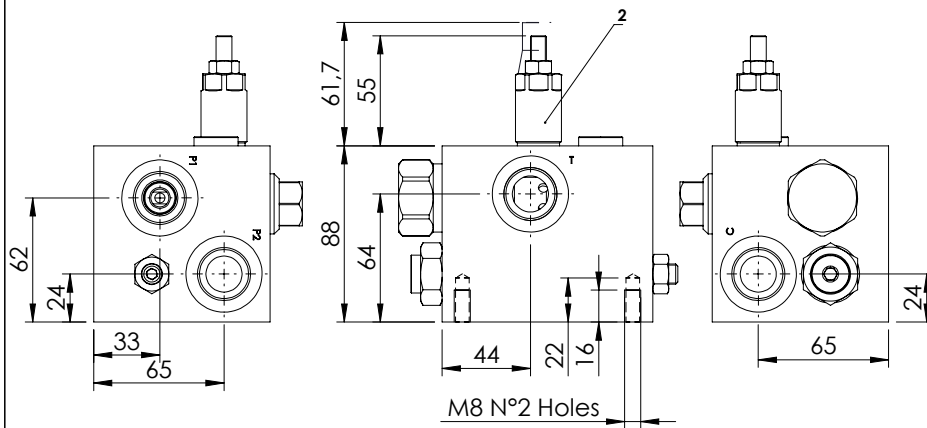
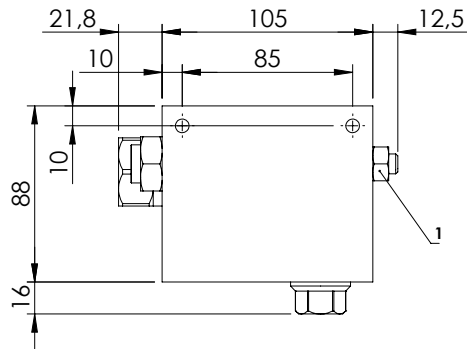

SPECIFICATIONS

Max. operating pressure:	300 bar
Rated flow:	150 l/min
Manifold:	See table
Weight:	Aluminium 2,54 kg; Steel 5,9 kg

SEALING CAP

Ordering code:
AT000020

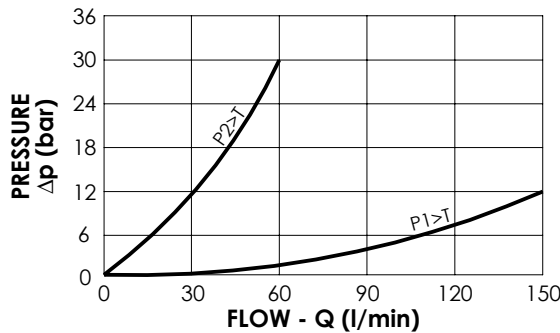
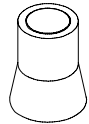

NOTES

ORDERING CODES

Quick code	Description	Manifold material	Main ports size	Standard setting (bar, Q=5 l/min)	Adjust. range (bar)	Pressure increase (bar/turn)
MT000012	MTSD-150-TLSN-00-G34-N300	Aluminium	P1,P2,C,T: G3/4"	① 50 ② 300	① 15-100 ② 100-350	① 23 ② 91
MT000016	MTSD-150-SLSN-00-G34-N300	Steel	P1,P2,C,T: G3/4"	① 50 ② 300	① 15-100 ② 100-350	① 23 ② 91

SECTION 14. 4

SPECIAL VALVES - FILTER BLOCKS



Hydraulic scheme	Valve description	Valve type	Rated flow (l/min)	Max. pressure (bar)	Installation	Main port size or cavity type	Page
	BPNN-025-LLU		25	100	In line	G 1/4"	14.04.010
	BPNN-025-LLEU		25	100	In line	JIS 1/4"	14.04.020

FILTER VALVE

BPNN-025-LLU

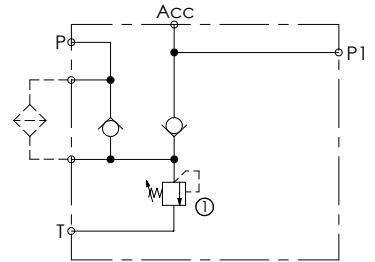
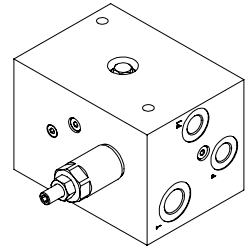
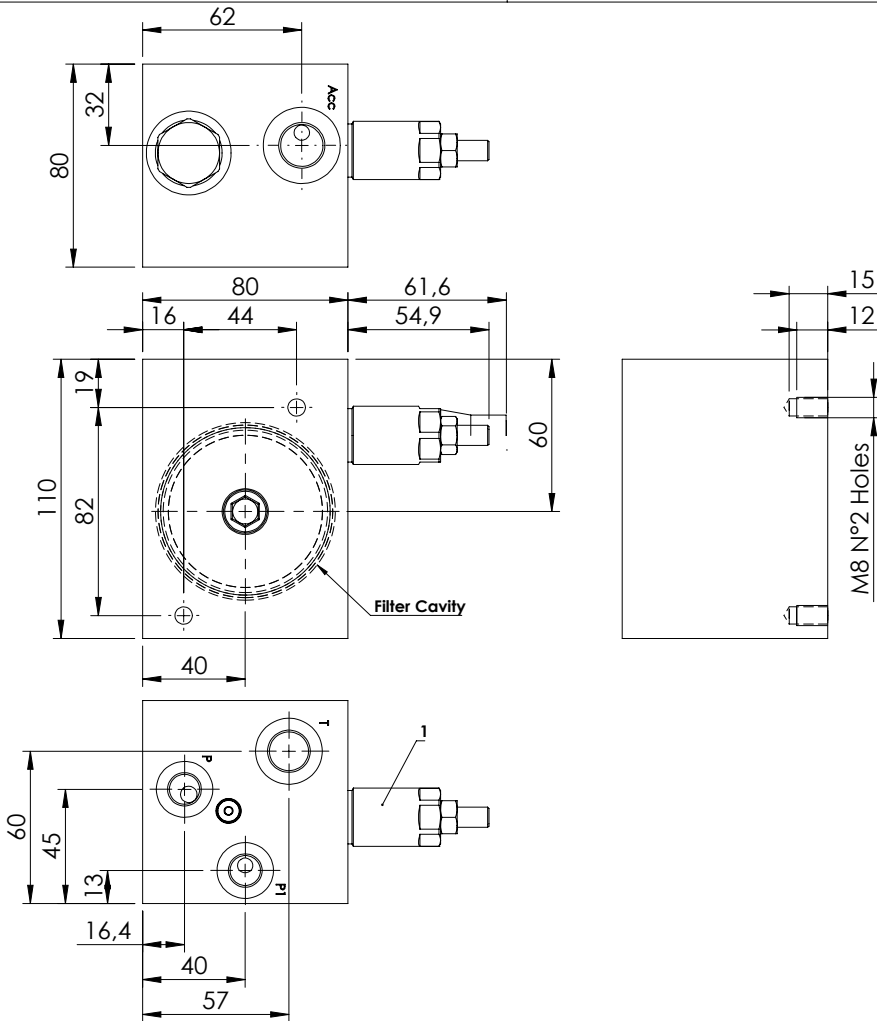

SPECIFICATIONS

Max. operating pressure:	100 bar
Rated flow:	25 l/min
Manifold:	Aluminium
Weight:	1,7 kg

SEALING CAP

Ordering code:
AT000020

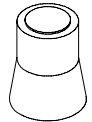

NOTES

-For filter cavity information or special version ask AFT sales network.

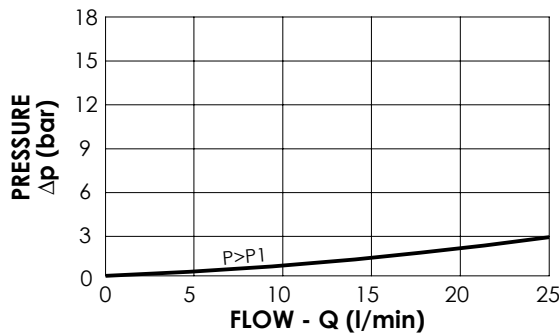

ORDERING CODES

Quick code	Description	Main ports size	Standard setting (bar, Q=5 l/min)	Adjust. range (bar)	Pressure increase (bar/turn)
BP000109	BPNN-025-LLU-NP-G38-N100	P1,P: G 1/4" T: G 3/8" Acc: M18x1,5	25	10-50	10

FILTER VALVES

BPNN-025-LLEU

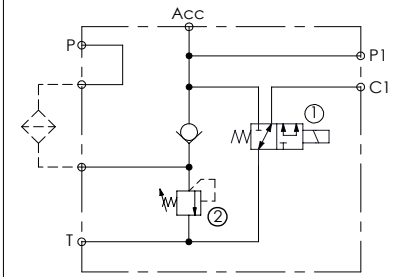
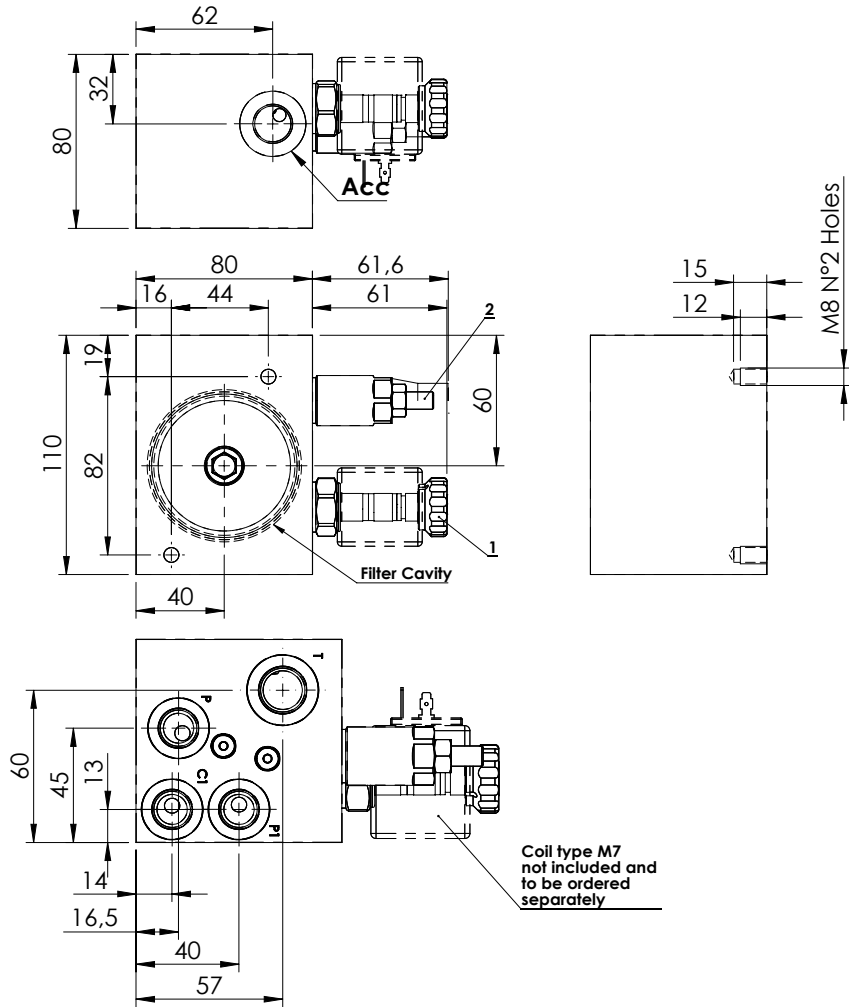
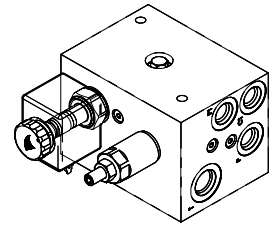

SPECIFICATIONS

Max. operating pressure:	100 bar
Rated flow:	25 l/min
Manifold:	Aluminium
Weight:	1,1 kg

SEALING CAP

Ordering code:
AT000020

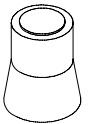

NOTES

- For filter cavity information or special version ask AFT sales network.
- See chapter 18.00.000 for coil.

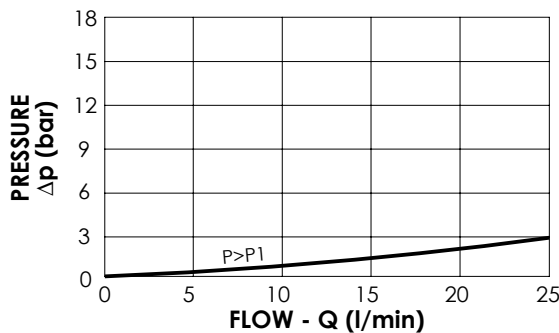

ORDERING CODES

Quick code	Description	Main ports size	Standard setting (bar, Q=5 l/min)	Adjust. range (bar)	Pressure increase (bar/turn)
BP000108	BPNN-025-LLEU-NP-J38-N100	C1,P1,P:1/4" JIS T:3/8" JIS	25	10-50	10



1800-OILSOL
1800-645765

<https://oilsolutions.com.au/>

sales@oilsolutions.com.au

SECTION 14. 5

SPECIAL VALVES - END OF STROKE VALVES



Hydraulic scheme	Valve description	Valve type	Rated flow (l/min)	Max. pressure (bar)	Installation	Main port size or cavity type	Page
	MDTC-060-ABNR	End of stroke, normally open, compensated	60	350	In line	G 3/8"	14.05.010
	MDTC-100-AVNR	End of stroke, normally closed	100	350	In line	G 1/2"	14.05.020
	MDTA-060-ABNR	End of stroke, normally open, compensated	60	350	In line	G 3/8"	14.05.030
	MDTA-100-AVNR	End of stroke, normally open, compensated	100	350	In line	G 1/2"	14.05.040
	MDTC-030-ABNR	End of stroke, normally closed	30	350	In line	G 3/8"	14.05.050
	MDTC-080-ABNR	End of stroke, normally closed	80	350	In line	G 3/8"	14.07.060

END OF STROKE VALVE

MDTC-060-ABNR

**NORMALLY CLOSED
COMPENSATED**

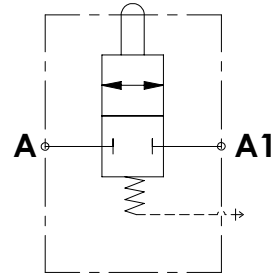
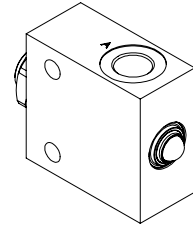
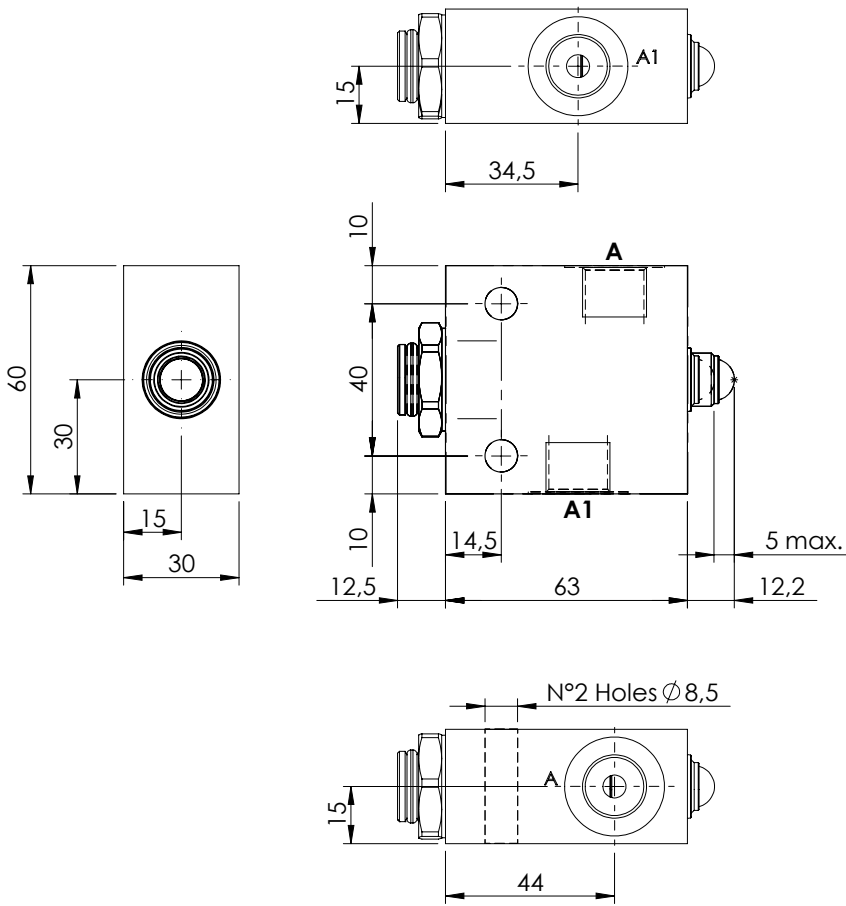

SPECIFICATIONS

Max. operating pressure:	350 bar
Rated flow:	60 l/min
Manifold:	Steel
Weight:	0,82 kg
Maximum stroke:	5 mm
Max. leakage at 150 bar when fully closed:	200 cc/min

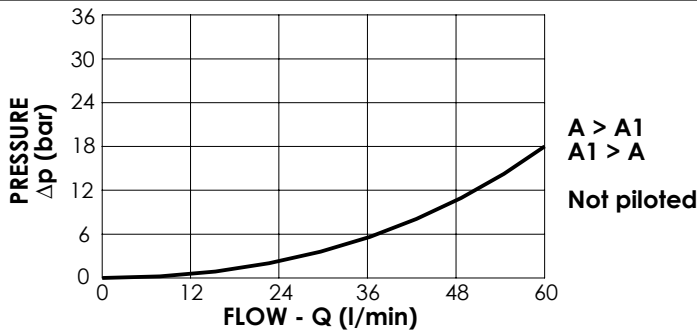

ORDERING CODES

Quick code	Description	Main ports size	Cracking pressure (Kg)	Fully open (Kg)
MD000090	MDTC-060-ABNR-NP-G38-N350	G 3/8"	4	13

END OF STROKE VALVE

MDTC-100-AVNR

**NORMALLY CLOSED
AIR VENTED**

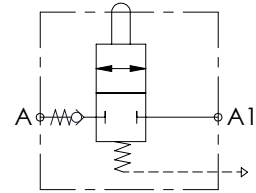
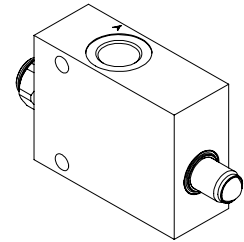
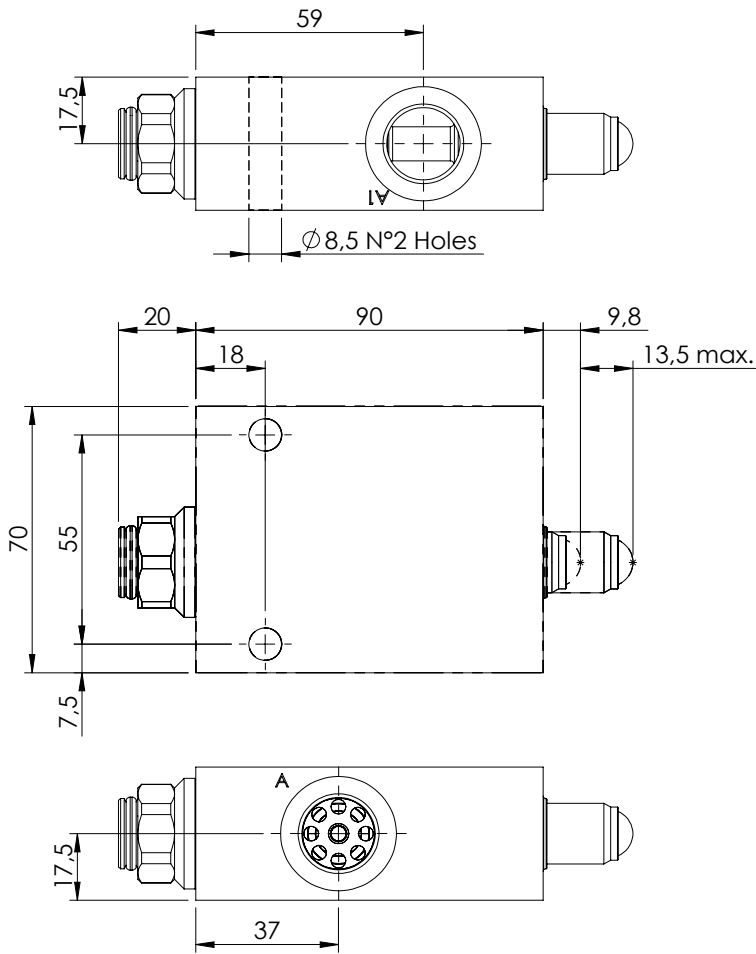

SPECIFICATIONS

Max. operating pressure:	350 bar
Rated flow:	100 l/min
Manifold:	Steel
Weight:	1,59 kg
Maximum stroke:	13,5 mm

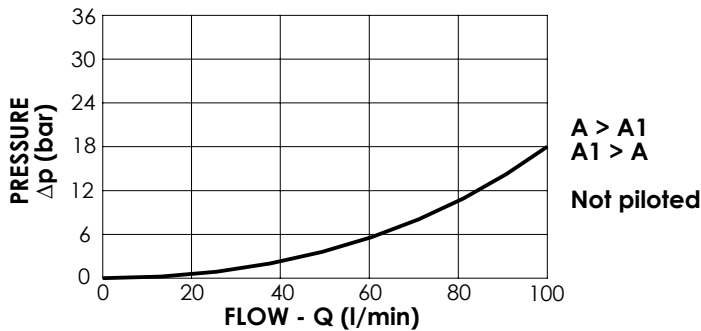

ORDERING CODES

Quick code	Description	Main ports size	Cracking pressure (Kg)	Fully open (Kg)
MD000091	MDTC-100-AVNR-NP-G12-N350	G 1/2"	5,3	14

END OF STROKE VALVE

MDTA-060-ABNR

**NORMALLY OPEN
COMPENSATED**

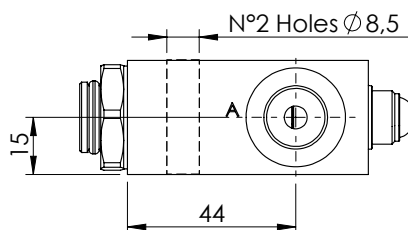
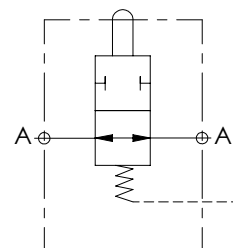
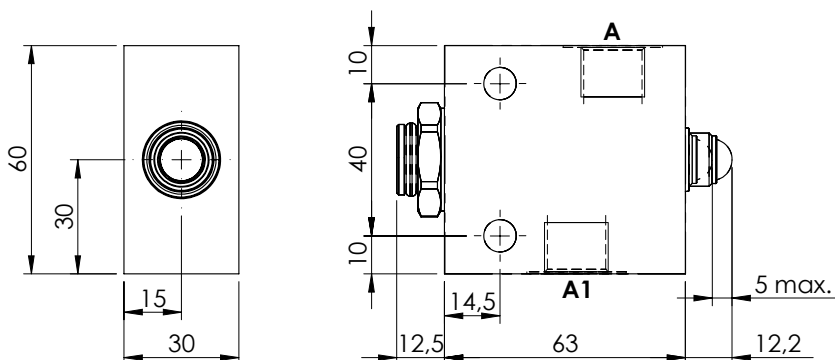
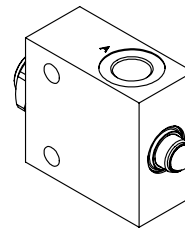
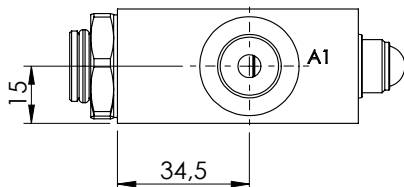

SPECIFICATIONS

Max. operating pressure:	350 bar
Rated flow:	60 l/min
Manifold:	Steel
Weight:	0,82 kg
Maximum stroke:	5 mm
Max. leakage at 150 bar when fully closed:	200 cc/min

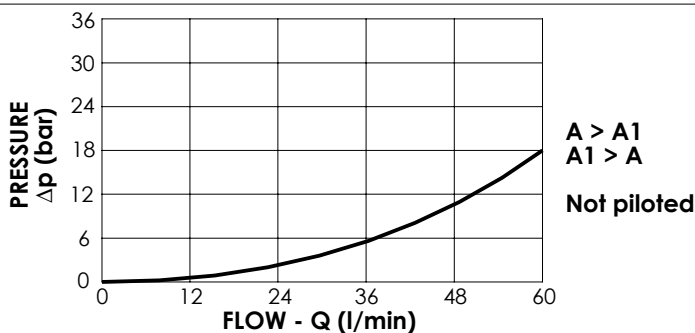

ORDERING CODES

Quick code	Description	Main ports size	Cracking pressure (Kg)	Fully closed (Kg)
MD000043	MDTA-060-ABNR-NP-G38-N350	G 3/8"	4	13

END OF STROKE VALVE

MDTA-100-AVNR

**NORMALLY OPEN
AIR VENTED**

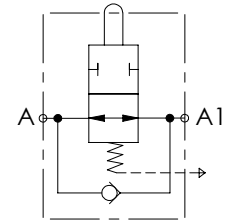
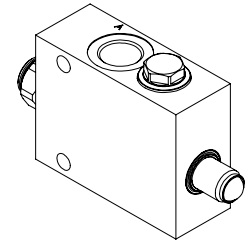
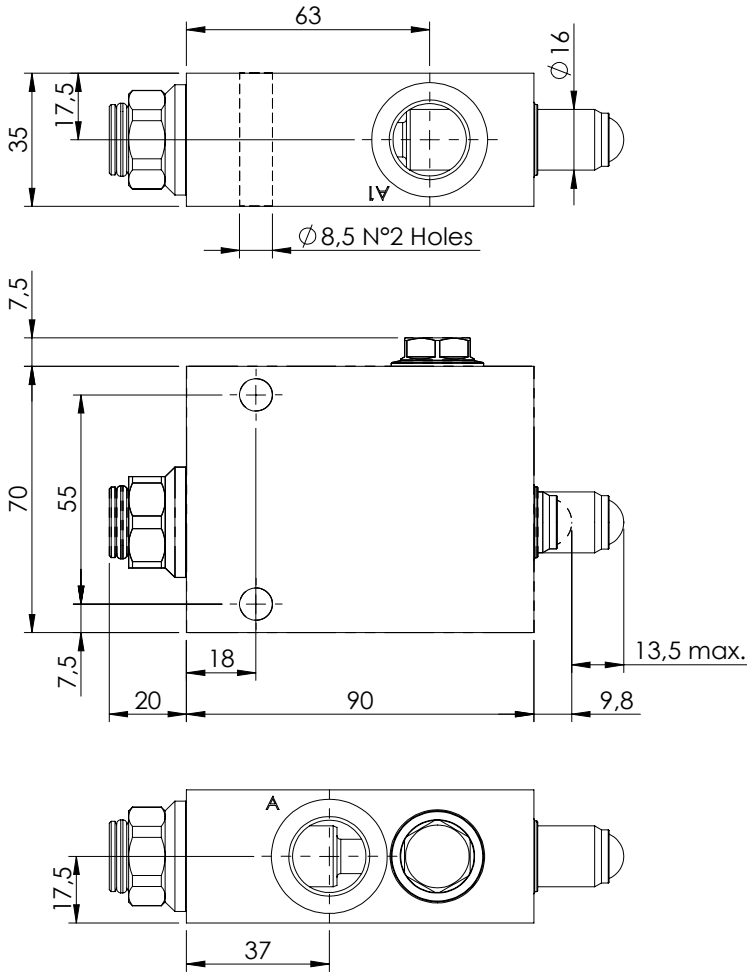

SPECIFICATIONS

Max. operating pressure:	350 bar
Rated flow:	100 l/min
Manifold:	Steel
Weight:	1,54 kg
Maximum stroke:	13,5 mm

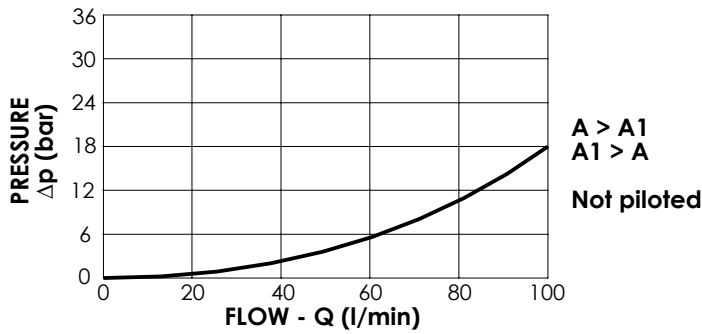

ORDERING CODES

Quick code	Description	Main ports size	Cracking pressure (Kg)	Fully closed (Kg)
MD000032	MDTA-100-AVNR-NP-G12-N350	G 1/2"	5,3	14

END OF STROKE VALVE

MDTC-030-ABNR

NORMALLY CLOSED

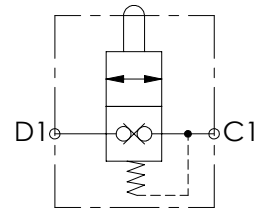
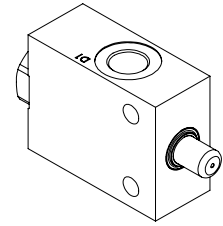
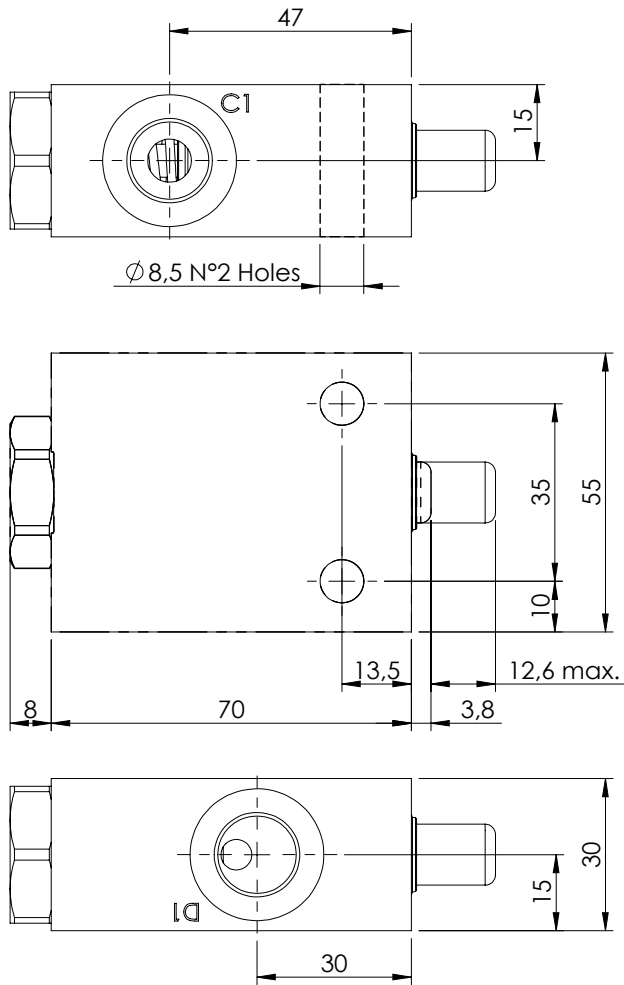

SPECIFICATIONS

Max. operating pressure:	350 bar
Rated flow:	30 l/min
Manifold:	Steel
Weight:	0,78 kg
Maximum stroke:	12,6 mm

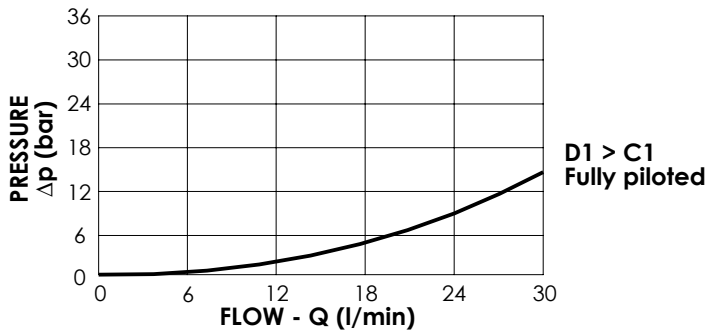

ORDERING CODES

Quick code	Description	Main ports size	Cracking pressure (Kg)	Fully open (Kg)
MD000064	MDTC-030-ABNR-NP-G38-N350	G 3/8"	9	19,7

END OF STROKE VALVE

MDTC-080-ABNR

NORMALLY CLOSED

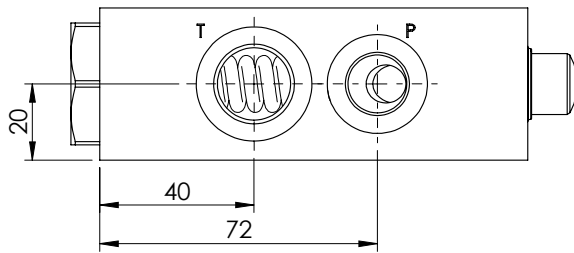
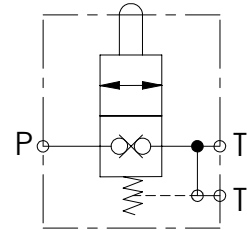
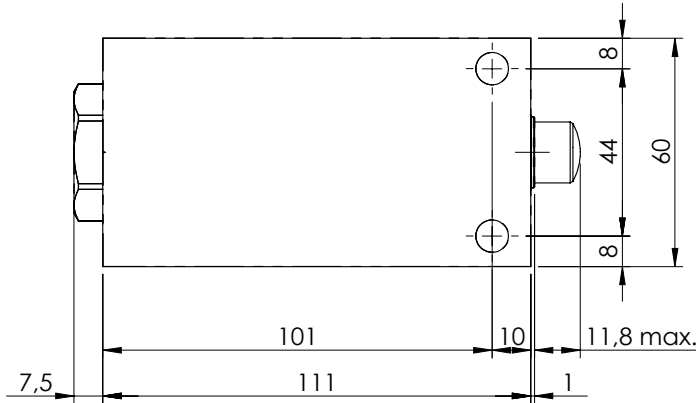
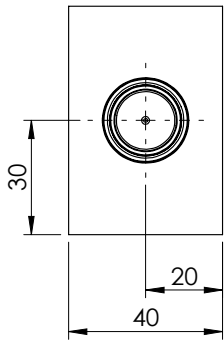
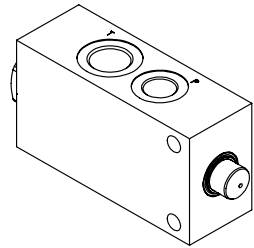
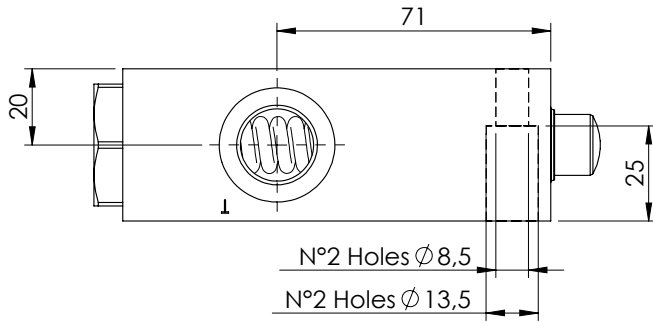

SPECIFICATIONS

Max. operating pressure:	350 bar
Rated flow:	80 l/min
Manifold:	Steel
Weight:	1,71 kg
Maximum stroke:	11,8 mm

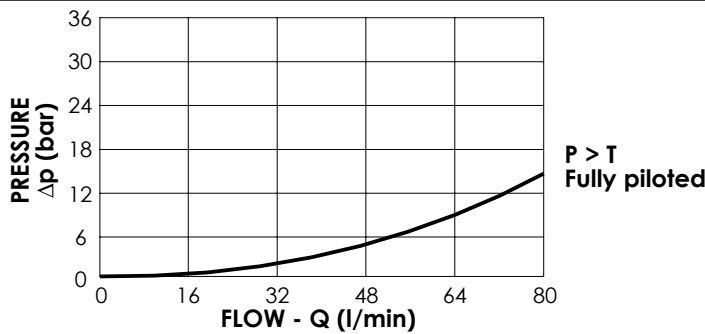

ORDERING CODES

Quick code	Description	Main ports size	Cracking pressure (Kg)	Fully open (Kg)
MD000044	MDTC-080-ABNR-NP-G38-N350	P: G 3/8" T: G 1/2"	36	119



1800-OILSOL
1800-645765

<https://oilsolutions.com.au/>

sales@oilsolutions.com.au

SECTION 14. 6

SPECIAL VALVES - PILOT BLOCKS



Hydraulic scheme	Valve description	Valve type	Rated flow (l/min)	Max. pressure (bar)	Installation	Main port size or cavity type	Page
	MDRD-020-SLN	ISO-SAE, Changeover valve	15	210/350	In line	G 1/2"	14.06.010
	BPRD-010-ALLS	Pilot manifold	10	350	In line	G 1/4"	14.06.020
	BNNR-015-AER	Pilot manifold	20	50	In line	G 1/4"	14.06.030
	BNND-010-LRE	Joystick safety stop	10	210	In line	G 3/8"	14.06.040
	BNND-003-LNQ-02	Proportional pressure reducing, pilot manifold	3	50	In line	G 1/4"	14.06.050
	BNND-003-LNQ-06	Proportional pressure reducing, pilot manifold	3	50	In line	G 1/4"	14.06.060
	BNND-003-LNQ-08	Proportional pressure reducing, pilot manifold	3	50	In line	G 1/4"	14.06.070
	BNND-003-LNQ-14	Proportional pressure reducing, pilot manifold	3	50	In line	G 1/4"	14.06.080

PILOT BLOCK

MDRD-020-SLN

**ISO-SAE
CHANGEOVER VALVE**

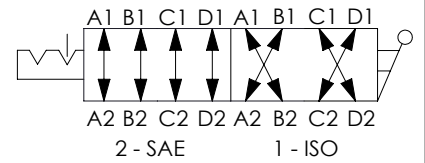
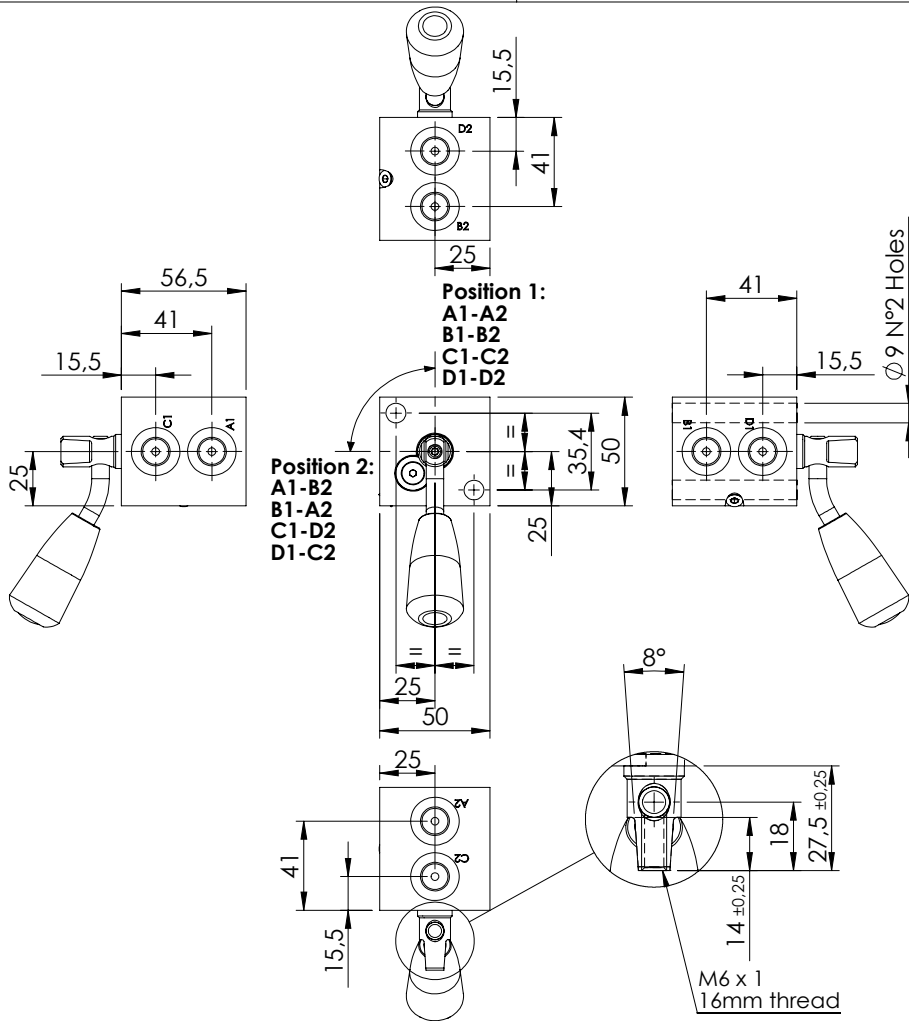
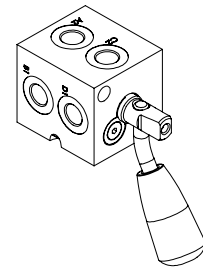

SPECIFICATIONS

Max. operating pressure:	50 bar
Rated flow:	20 l/min
Body:	Steel
Weight:	1 kg
Position shown:	1 - ISO position

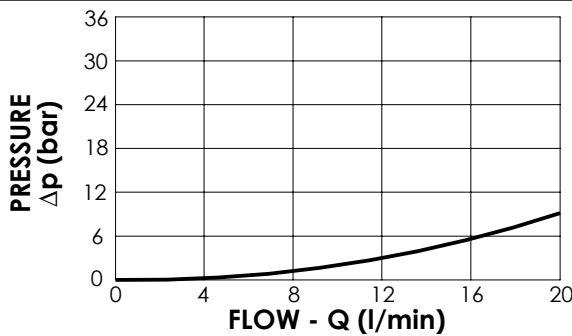

ORDERING CODES

Quick code	Description	Ports size	
MD000071	MDRD-020-SLN-NP-G14-N350	G 1/4"	

PILOT BLOCK

BPRD-010-ALLS

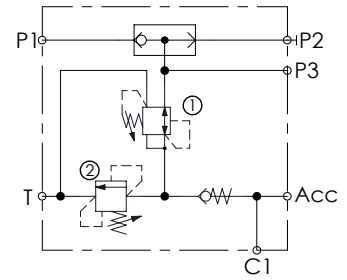
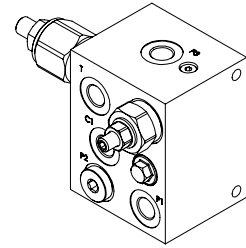
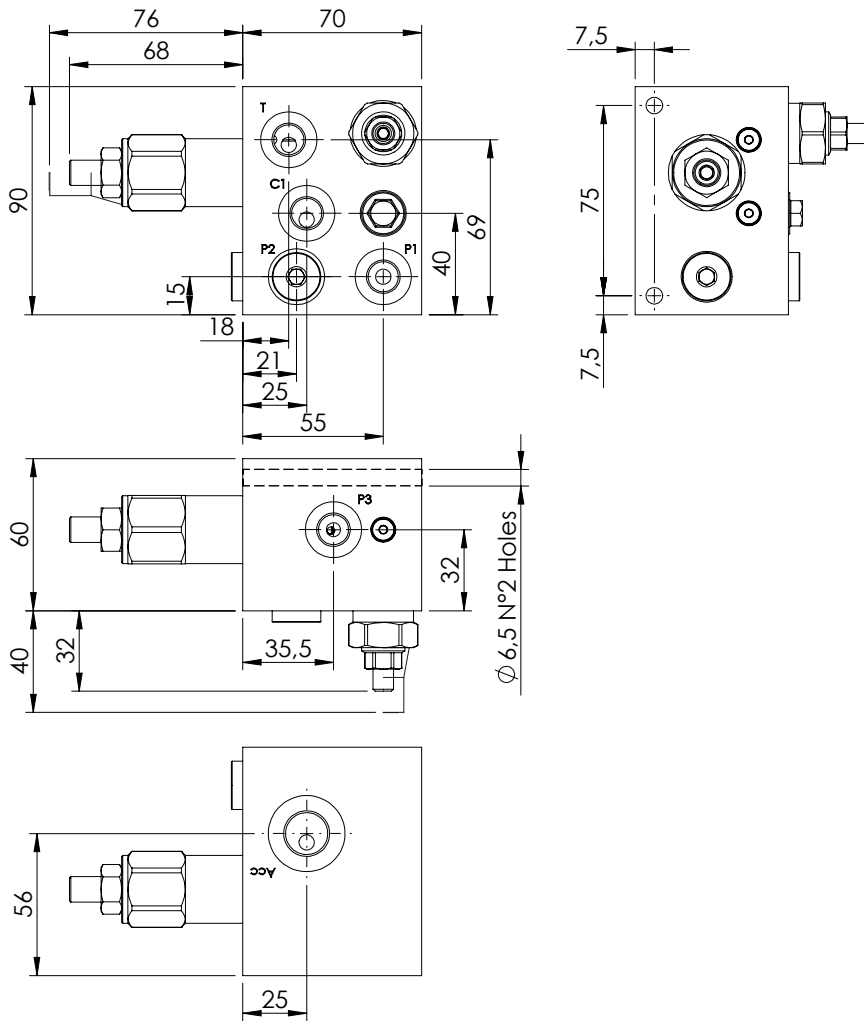

SPECIFICATIONS

Max. operating pressure:	350 bar
Rated flow:	10 l/min
Weight:	3 kg
Coil type:	Steel

SEALING CAP

Ordering codes:

AT00021
(Valve n°1)

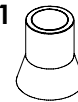

AT00020
(Valve n°2)

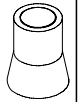

NOTE

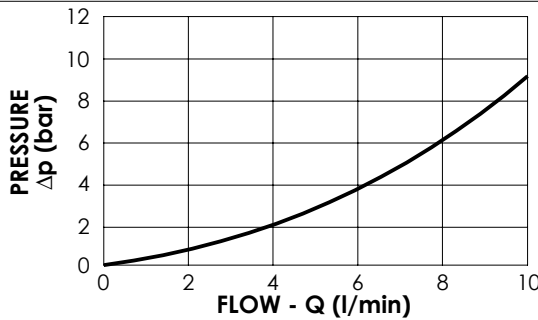

ORDERING CODES

Quick code	Description	Port size	Standard setting (bar)	Adjust. range (bar)	Pressure increase (bar/turn)
BP000113	BPRD-010-ALLS-NP-G14-N350	P1,P2,P3,C1,T: G 1/4" Acc: M18x1,5	① 35 bar ② 50 bar @ 5 l/min	① 10 - 50 ② 10 - 70	① 7 ② 26

PILOT BLOCK

BNND-015-AER

PILOT MANIFOLD

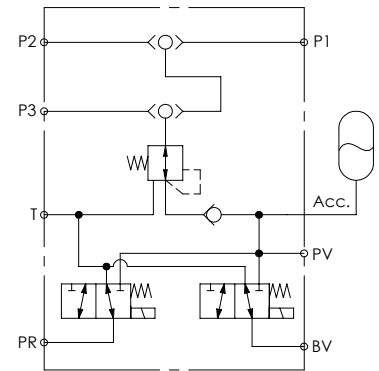
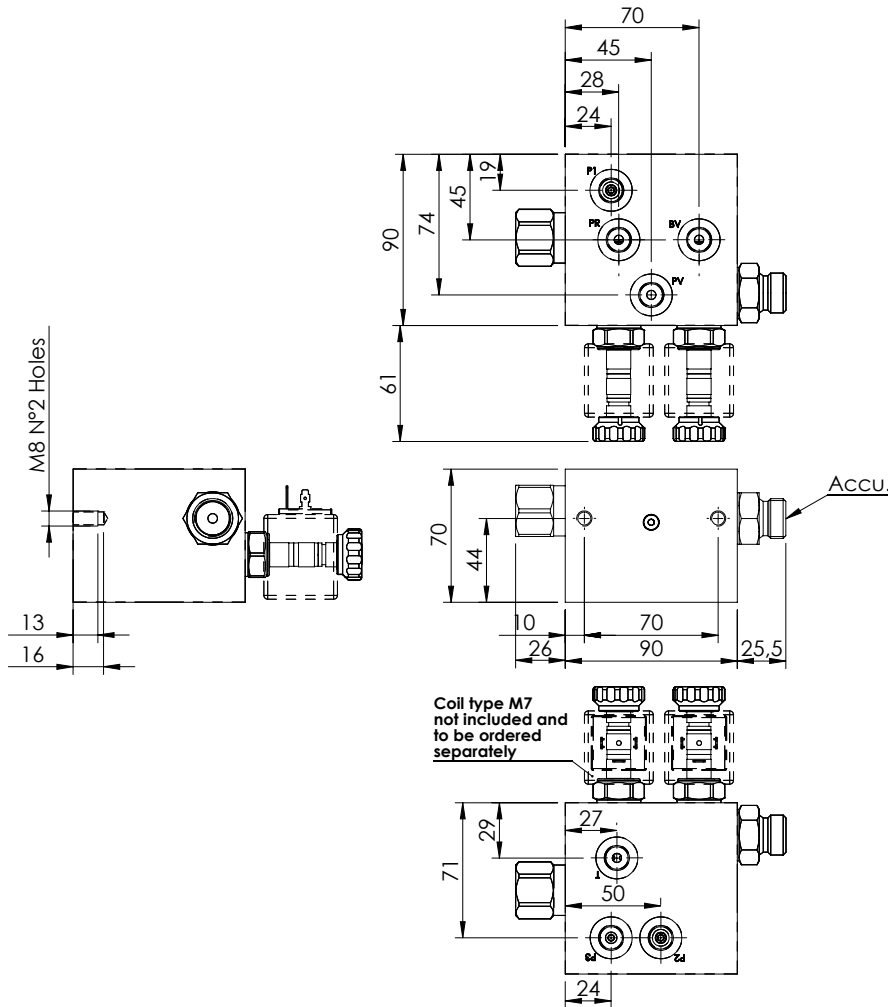
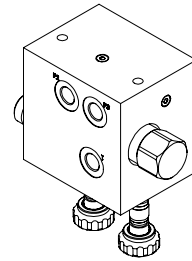

SPECIFICATIONS

Max. operating pressure:	350/210 bar
Rated flow:	15 l/min
Weight:	Steel 4,5 kg; Aluminium 1,9 kg
Coil type:	M7

NOTES

Rated flow in inlet: 15 l/min
 Rated flow from accumulator: 45 l/min
 Pressure reducing valve with stabilization system
 Othercoil/voltage available on request
 See chapter 18.00.000 for coil.

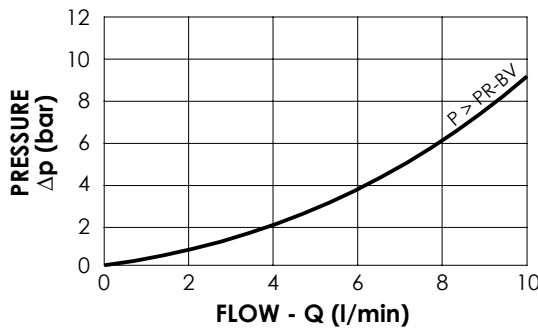

ORDERING CODES

Quick code	Description	Port size	Manifold material	Standard setting (bar)	
BD000205	BNND-015-AER-G14-N350	P1, P2, P3, PR, PV,BV, T: G 1/4" Acc: G 1/2"	Steel	35	
BD000087	BNND-015-LER-G14-N210	P1, P2, P3, PR, PV,BV, T: G 1/4" Acc: G 1/2"	Aluminium	35	

PILOT BLOCK

BNND-010-LRE

**JOYSTICK SAFETY STOP
SOLENOID OPERATED**

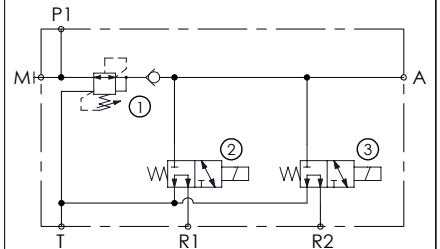
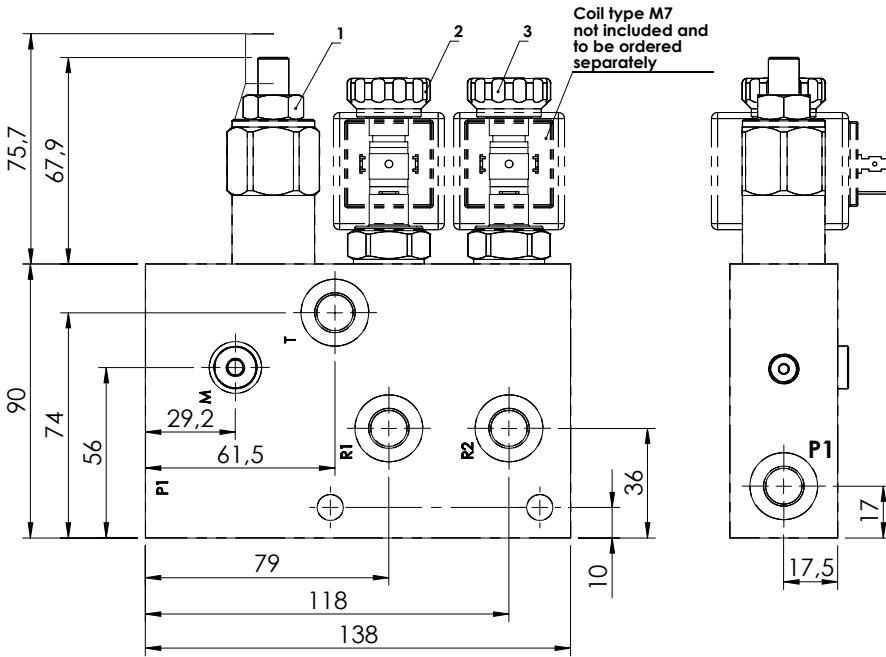
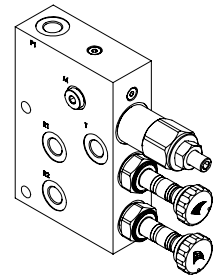
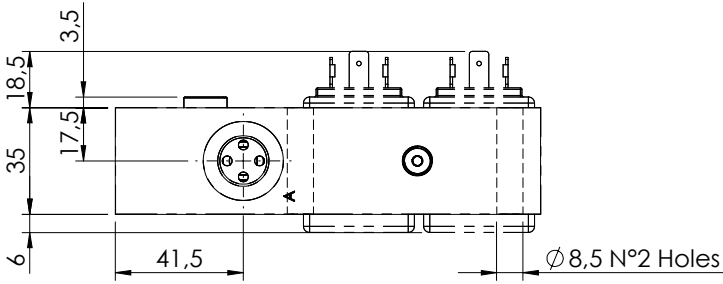

SPECIFICATIONS

Max. operating pressure:	210 bar
Rated flow:	10 l/min
Manifold:	Steel
Weight:	3,2 kg
Coil type:	M7

SEALING CAP

Ordering code:
AT000021

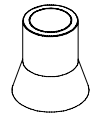

NOTES

-See chapter 18.00.000 for coil.

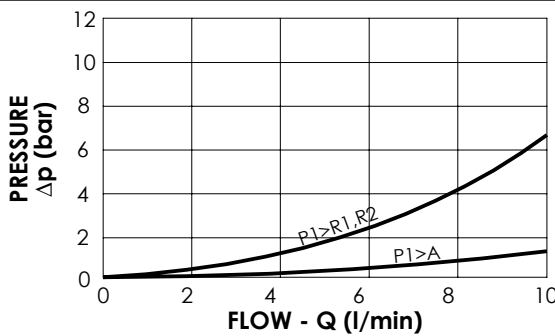

ORDERING CODES

Quick code	Description	Main ports size	Standard setting (bar)	Adjustm. range (bar)	Pressure increase (bar/turn)
BD000197	BNND-010-LRE-NP-G38-N210	R1,R2,T,P1: G1/4" A: G3/8" M: G1/8"	35	10-50	7

PILOT BLOCK

BNND-003-LNQ

**PROPORTIONAL
PRESSURE REDUCING
PILOT MANIFOLD**

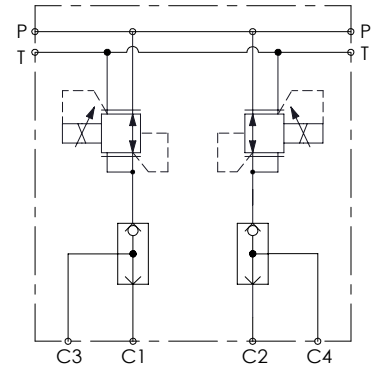
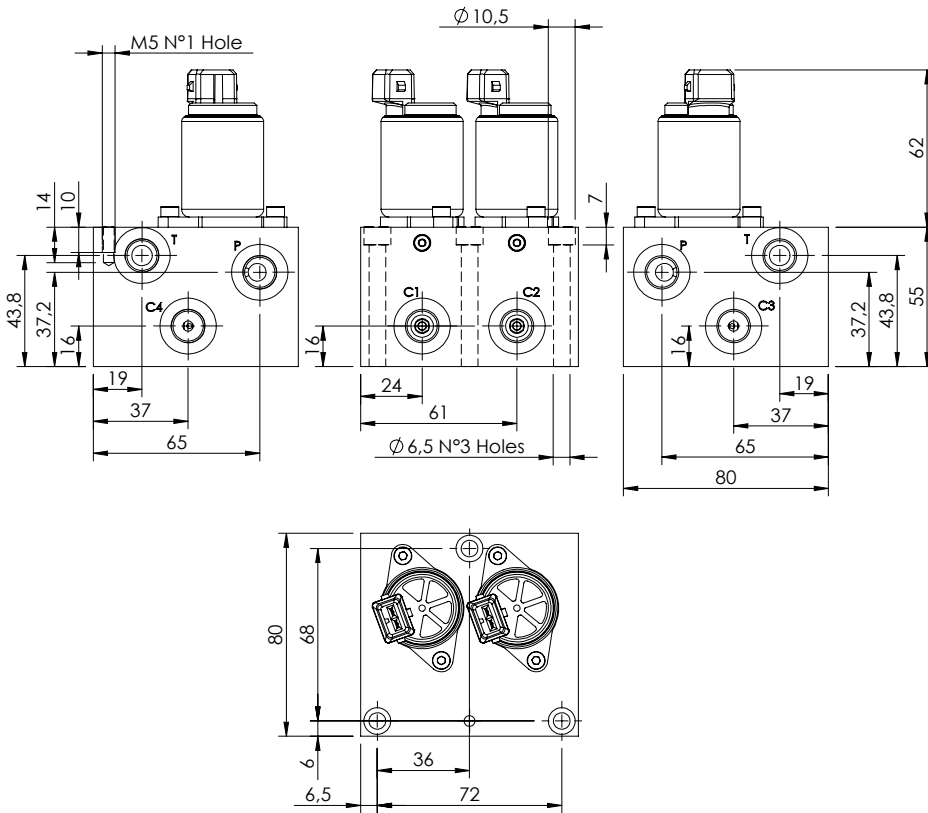
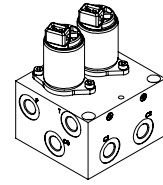

SPECIFICATIONS

Max. operating pressure:	50 bar
Rated flow:	3 l/min
Manifold:	Aluminium
Weight:	0,9 kg

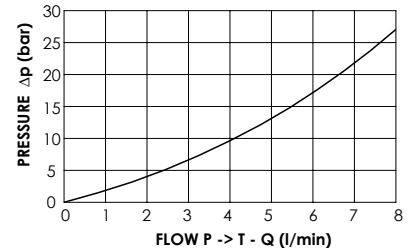
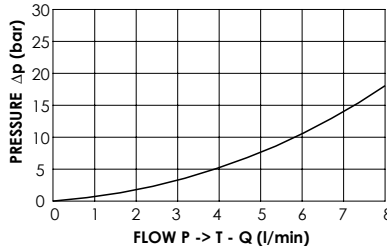
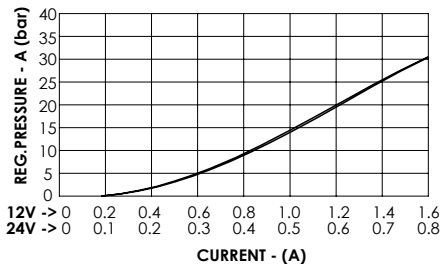

ORDERING CODES

Quick code	Description	Main ports size	Regulated pressure range (bar)	Voltage (V)	Connector type
BD000142	BNND-003-LNQ-02-G14-NBAJ	G 1/4"	0-25	24 DC	AMP JUNIOR
BD000127	BNND-003-LNQ-02-G14-NAAJ	G 1/4"	0-25	12 DC	AMP JUNIOR

PILOT BLOCK

BNND-003-LNQ

**PROPORTIONAL
PRESSURE REDUCING
PILOT MANIFOLD**

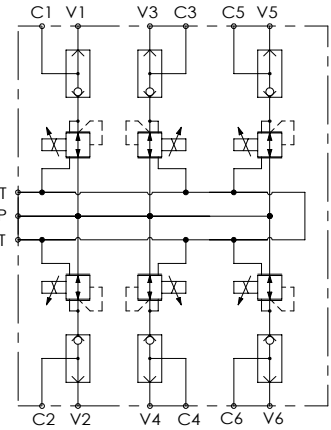
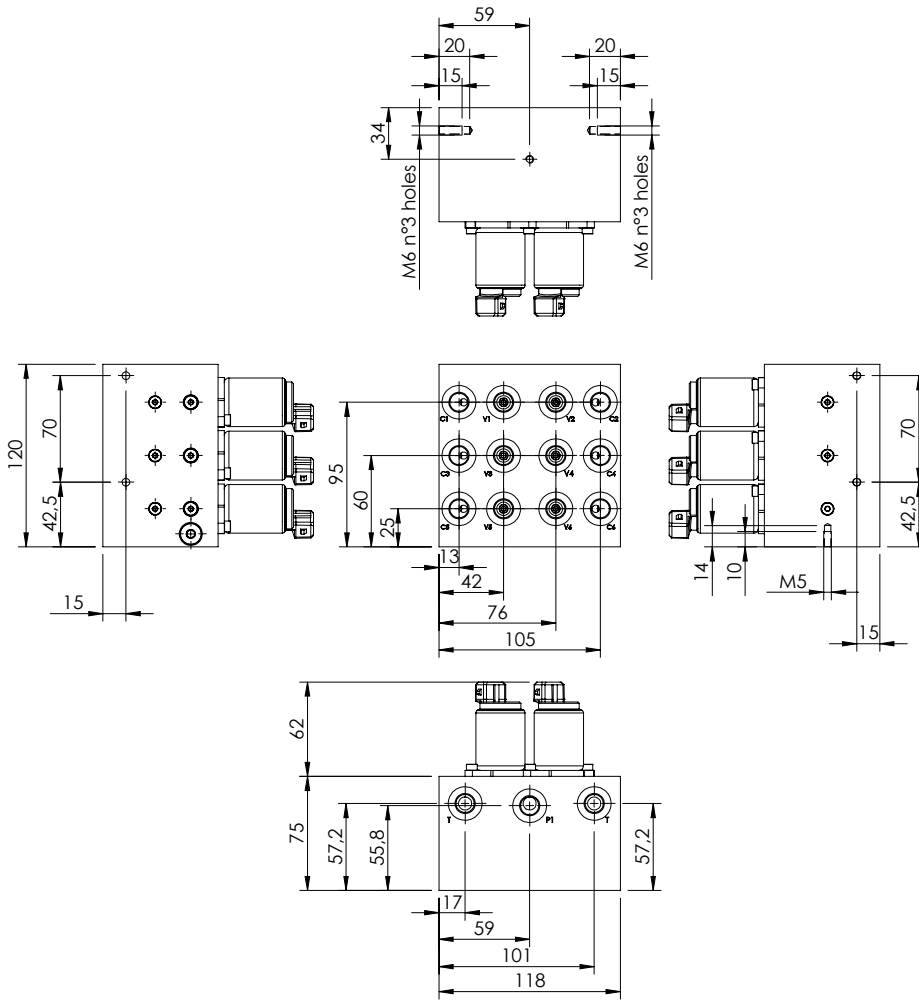
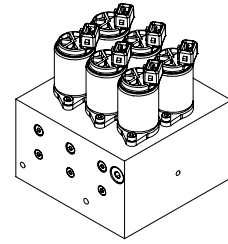

SPECIFICATIONS

Max. operating pressure:	50 bar
Rated flow:	3 l/min
Manifold:	Aluminium
Weight:	2,6 kg

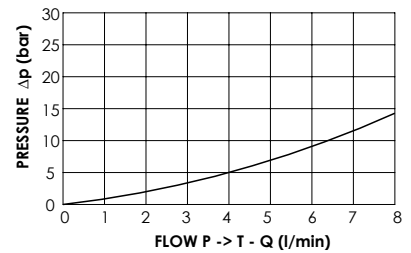
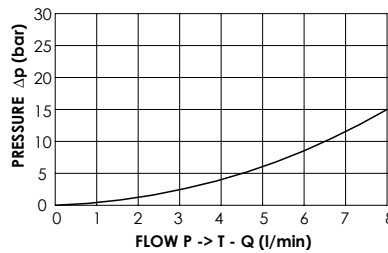
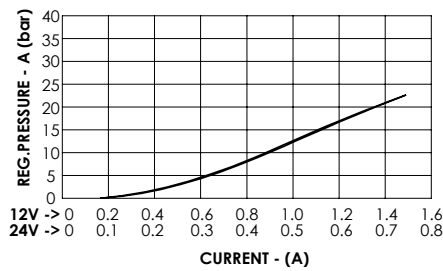

ORDERING CODES

Quick code	Description	Main ports size	Regulated pressure range (bar)	Voltage (V)	Connector type
BD000084	BNND-003-LNQ-06-G14-NBAJ	G 1/4"	0-20	24 DC	AMP JUNIOR
BD000202	BNND-003-LNQ-06-G14-NAAJ	G 1/4"	0-20	12 DC	AMP JUNIOR

PILOT BLOCK

BNND-003-LNQ

**PROPORTIONAL
PRESSURE REDUCING
PILOT MANIFOLD**

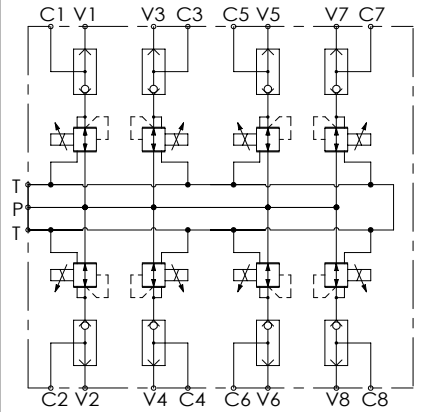
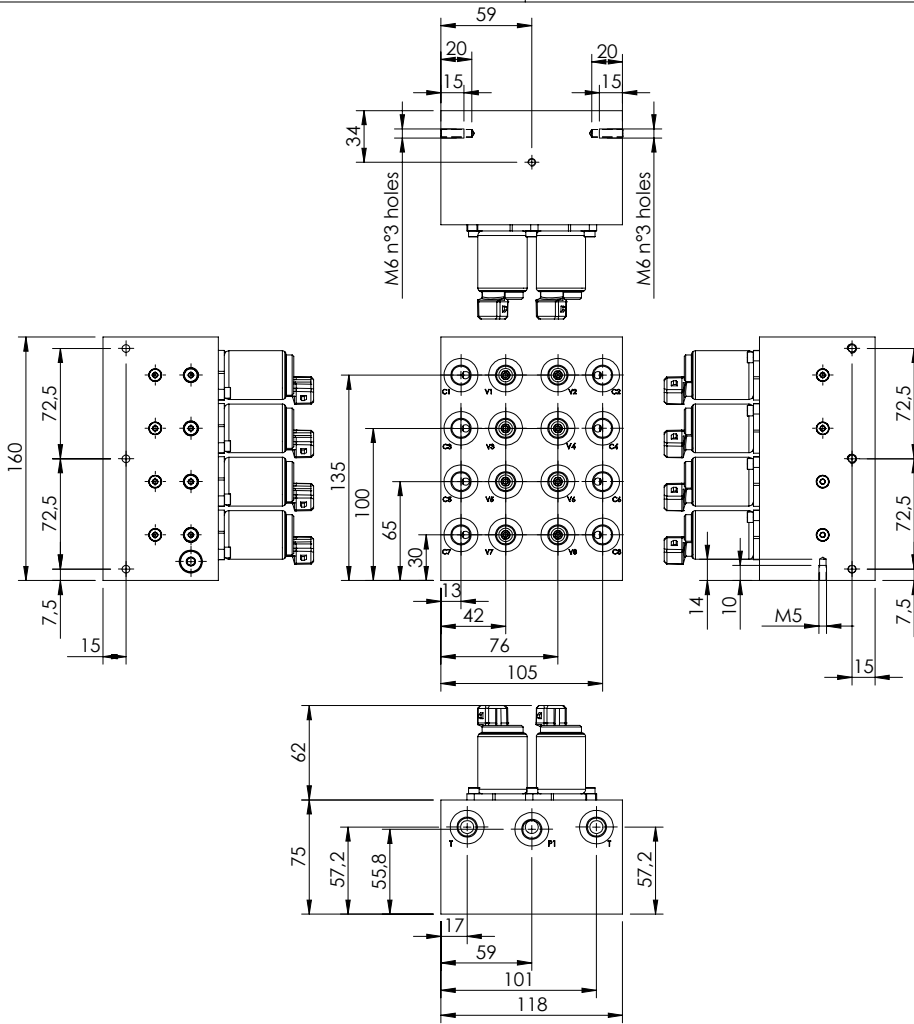
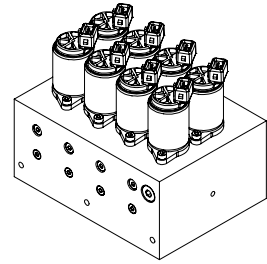

SPECIFICATIONS

Max. operating pressure:	50 bar
Rated flow:	3 l/min
Manifold:	Aluminium
Weight:	3,6 kg

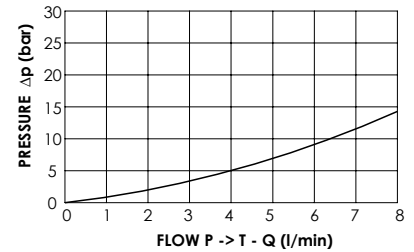
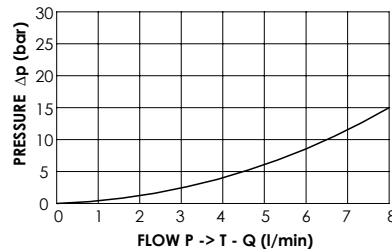
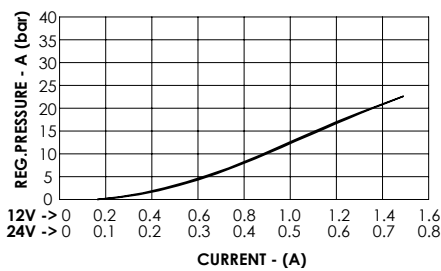

ORDERING CODES

Quick code	Description	Main ports size	Regulated pressure range (bar)	Voltage (V)	Connector type
BD000088	BNND-003-LNQ-08-G14-NBAJ	G 1/4"	0-20	24 DC	AMP JUNIOR
BD000201	BNND-003-LNQ-08-G14-NAAJ	G 1/4"	0-20	12 DC	AMP JUNIOR

PILOT BLOCK

BDEZ-005-LLSN

**PROPORTIONAL
PRESSURE REDUCING
PILOT MANIFOLD**

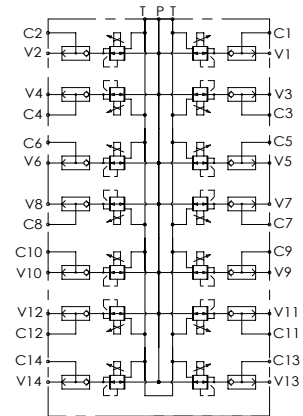
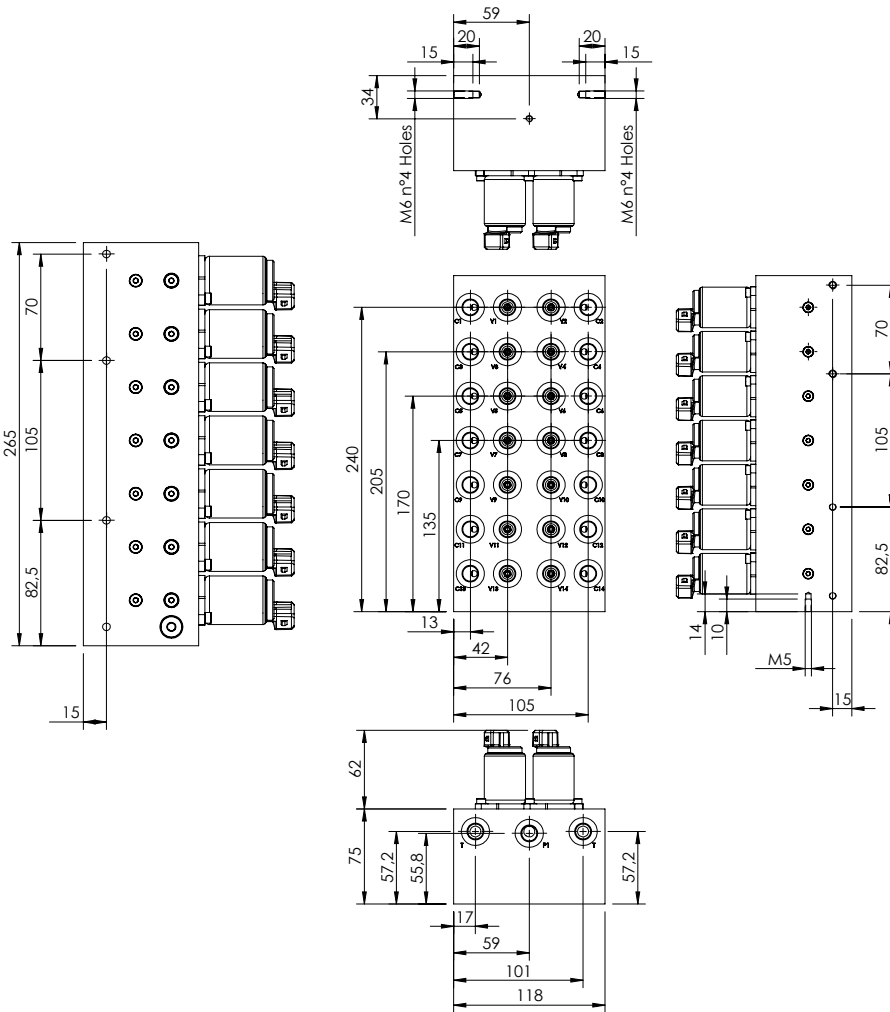
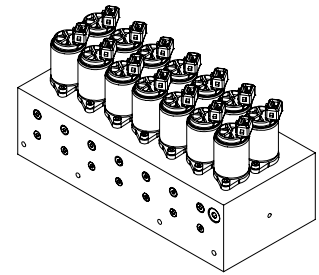

SPECIFICATIONS

Max. operating pressure:	50 bar
Rated flow:	3 l/min
Manifold:	Aluminium
Weight:	5,8 kg

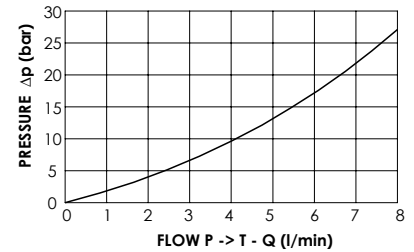
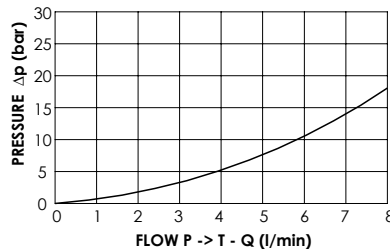
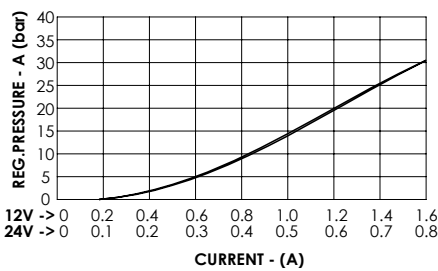

ORDERING CODES

Quick code	Description	Main ports size	Regulated pressure range (bar)	Voltage (V)	Connector type
BD000203	BDEZ-005-LLSN-14-G14-N050-NBAJ	G 1/4"	0-25	24 DC	AMP JUNIOR
BD000204	BDEZ-005-LLSN-14-G14-N050-NAAJ	G 1/4"	0-25	12 DC	AMP JUNIOR



1800-OILSOL
1800-645765

<https://oilsolutions.com.au/>

sales@oilsolutions.com.au

SECTION 14. 7

SPECIAL VALVES - AUTOMATIC SWITCHING VALVES

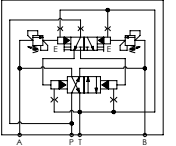
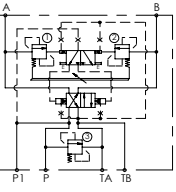
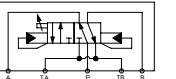

Hydraulic scheme	Valve description	Valve type	Rated flow (l/min)	Max. pressure (bar)	Installation	Main port size or cavity type	Page
	MDAP-040-NNNR	Spool type, pressure switching	40	350	Flanged	Cetop 3	14.07.010
	MDAP-090-NNNR	Spool type, pressure switching	90	350	Flanged	Cetop 5	14.07.020
	MDAP-090-NNNR	Spool type, pressure switching	90	250	Flanged	Cetop 5	14.07.030
	MDAF-080-ANNR	Spool type, flow switching, P in A start	80	350	Flanged	Cetop 5	14.07.040

AUTOMATIC DIRECTIONAL VALVE

MDAP-040-NNNR PRESSURE SWITCHING

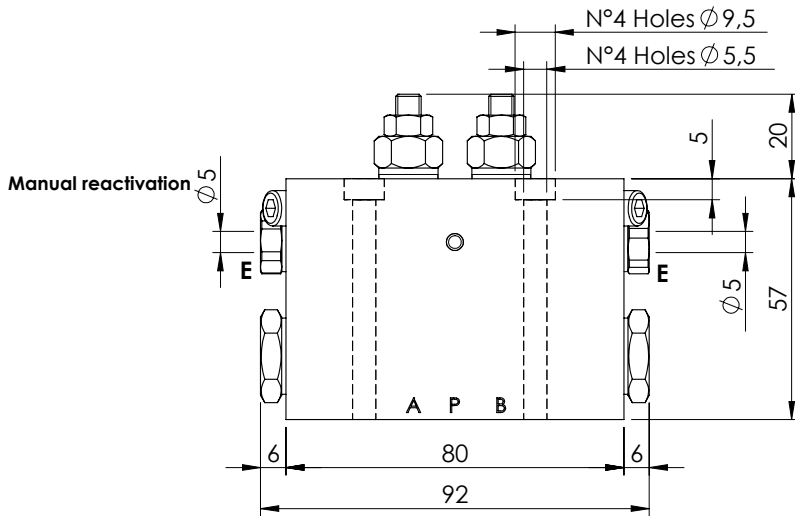
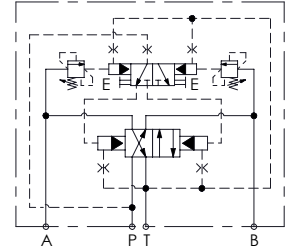
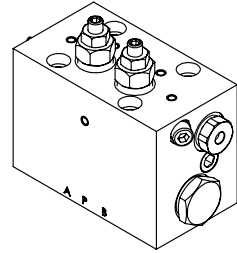
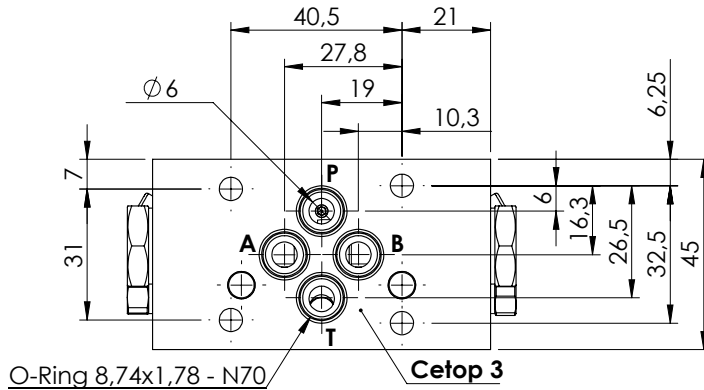

SPECIFICATIONS

Max. operating pressure:	350 bar
Rated flow:	40 l/min
Manifold:	Black galvanized cast iron
Weight:	1,48 kg

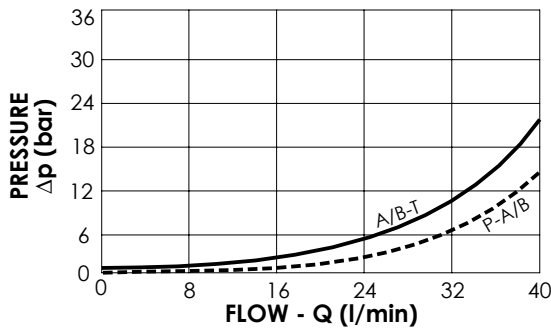

NOTES

- Minimum required flow: 3 l/min
- Actuator working pressure should always be lower than the automatic switching valve relief setting.
- Automatic switching valve relief setting should always be lower than pump relief valve setting.

ORDERING CODES

Quick code	Description	Main ports size	Standard setting (bar, Q=5 l/min)	Adjust. range (bar)	Pressure increase (bar/turn)
MD000027	MDAP-040-NNNR-NP-N06-N350	A,B,P,T : CETOP 3	350	100-350	95
MD000026	MDAP-040-NNNR-NP-N06-N200	A,B,P,T : CETOP 3	200	50-210	51
MD000025	MDAP-040-NNNR-NP-N06-N100	A,B,P,T : CETOP 3	100	15-100	26

AUTOMATIC DIRECTIONAL VALVE



MDAP-090-NNNR

PRESSURE SWITCHING

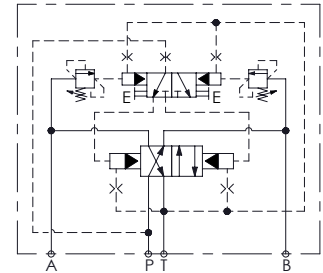
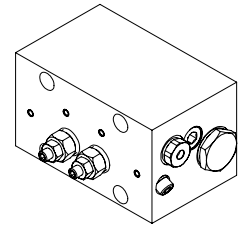
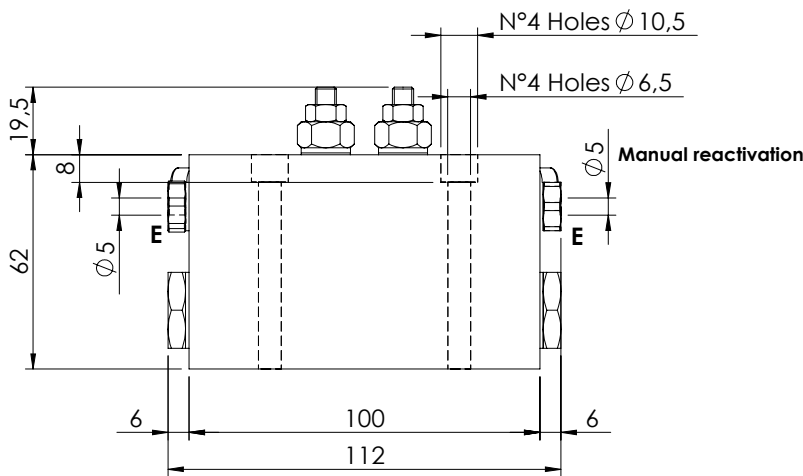
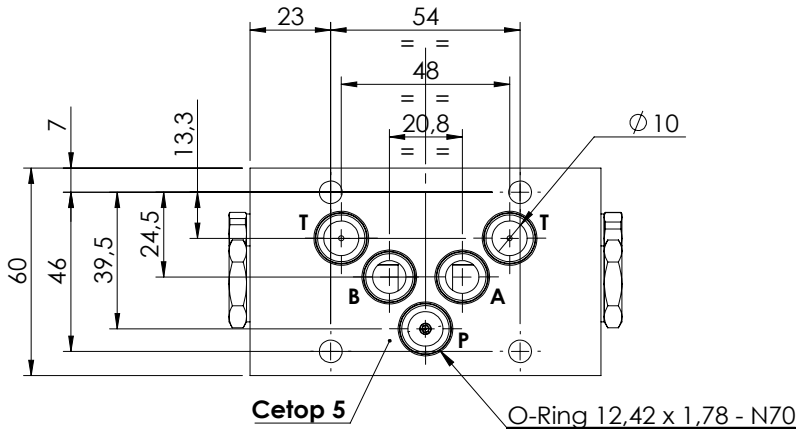

SPECIFICATIONS

Max. operating pressure:	350 bar
Rated flow:	90 l/min
Manifold:	Cast iron
Weight:	2,64 kg

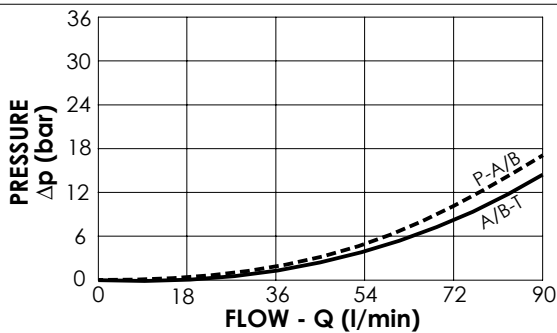

NOTES

Minimum required flow: 3 l/min

ORDERING CODES

Quick code	Description	Main ports size	Standard setting (bar, Q=5 l/min)	Adjust. range (bar)	Pressure increase (bar/turn)
MD000030	MDAP-090-NNNR-NP-N10-N350	A,B,P,T: CETOP 5	350	100-350	95
MD000029	MDAP-090-NNNR-NP-N10-N200	A,B,P,T: CETOP 5	200	50-210	51
MD000028	MDAP-090-NNNR-NP-N10-N100	A,B,P,T: CETOP 5	100	15-100	26

AUTOMATIC DIRECTIONAL VALVE

MDAP-090-NNNR PRESSURE SWITCHING

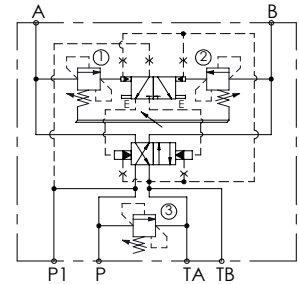
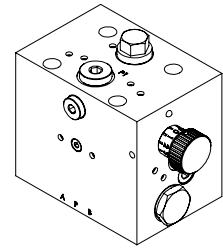
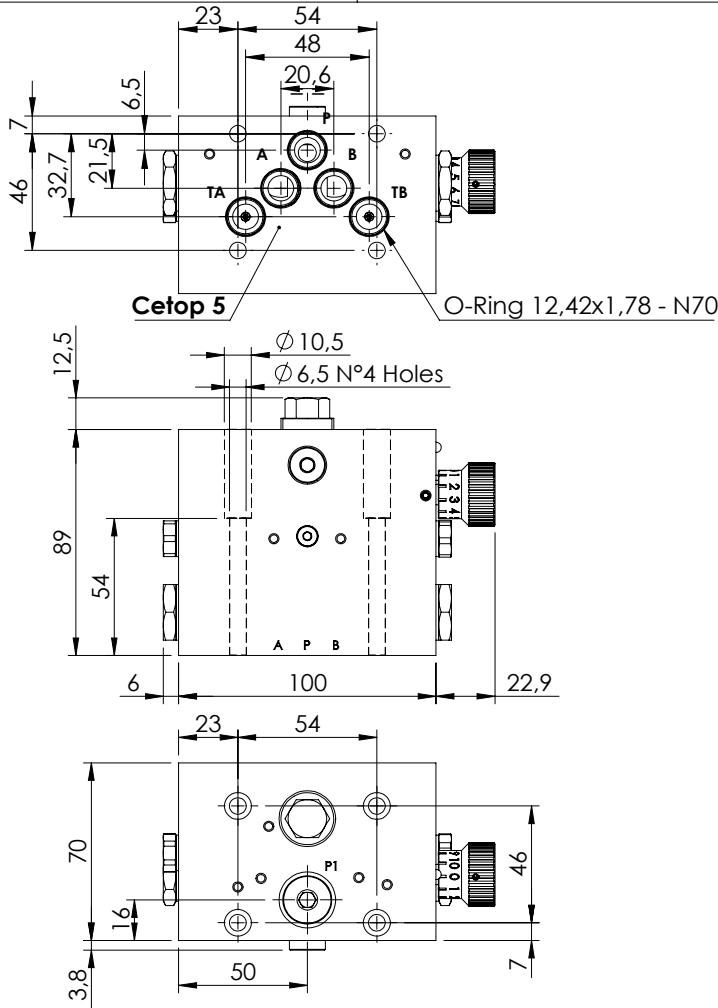

SPECIFICATIONS

Max. operating pressure:	350 bar
Rated flow:	90 l/min
Manifold:	Cast Iron
Weight:	4,45 kg

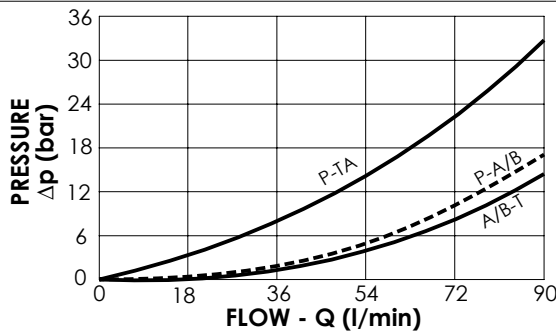

NOTES

Minimum required flow: 3 l/min

ORDERING CODES

Quick code	Description	Main ports size	Standard setting (bar, Q=5 l/min)	Adjust. range (bar)	Pressure increase (bar/turn)
MD000119	MDAP-090-NNNR-NP-N10-N350	A,B,P,TA,TB: CETOP 5 P1: G 1/4"	① ② 180 ③ 200	① ② 140-350	① ② 146
				Fix setting	

AUTOMATIC DIRECTIONAL VALVE

MDAF-080-ANNR

FLOW SWITCHING

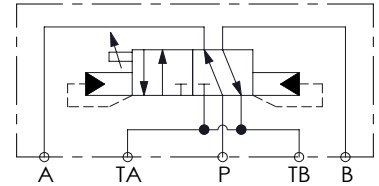
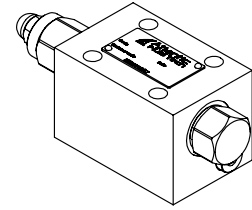
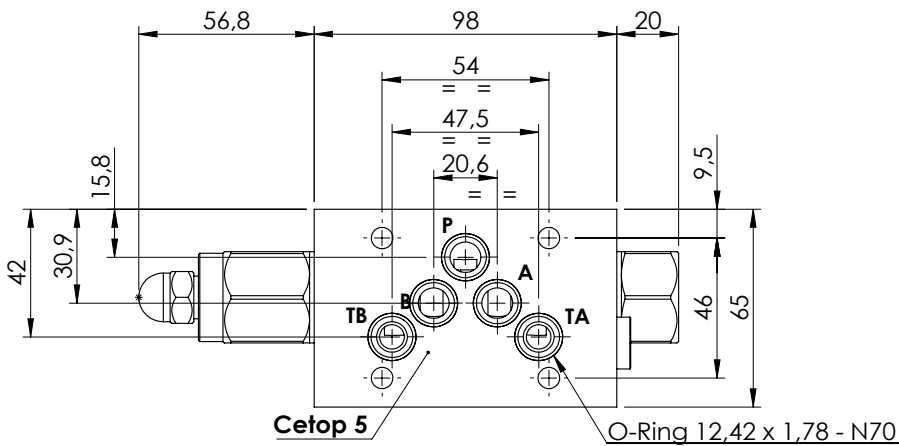
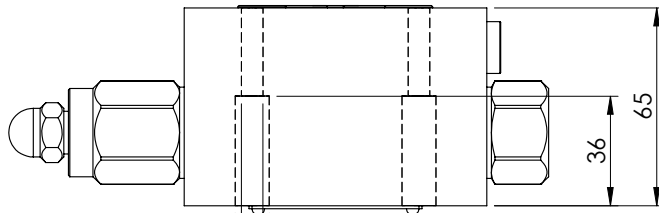

SPECIFICATIONS

Max. operating pressure:	350 bar
Rated flow:	80 l/min
Manifold:	Cast iron
Weight:	3,12 kg

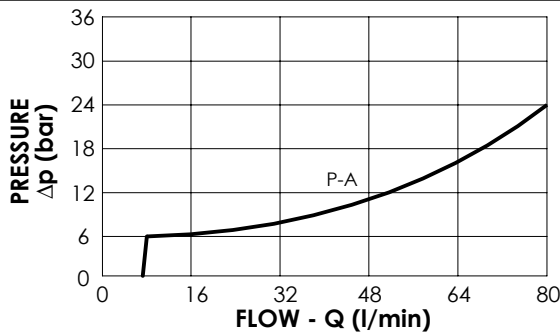

NOTES

- Minimum required flow: 6 l/min
- Flexible pipe should be placed between valve and cylinder rod side
- No suitable motor

ORDERING CODES

Quick code	Description	Main ports size	
MD000034	MDAF-080-ANNR-NP-N10-N350	A,P,B,TA,TB : CETOP 5	



1800-OILSOL
1800-645765

<https://oilsolutions.com.au/>

sales@oilsolutions.com.au

SECTION 14. 8

SPECIAL VALVES - LOAD LIMITING DEVICE VALVES



Hydraulic scheme	Valve description	Valve type	Rated flow (l/min)	Max. pressure (bar)	Installation	Main port size or cavity type	Page
	BDMN-010-LLCI	Hydraulic pressure, unloading, 3 ways	10	210	In line	G 1/4"	14.08.010
	MTP-003-TLSN	Hydraulic pressure, unloading, 2 ways	3	350	In line	G 1/4"	14.08.020
	MTSN-120-TLNR	Hydraulic pressure, unloading, kick down system	120	350	In line	G 1/4"	14.08.030
	MTL-005-TLSR	Pilot pressure, unloading	5	350	In line	G 1/4"	14.08.040
	MTR-005-TLSN	Pilot pressure, unloading, flange for pressure switch	5	350	In line	G 1/4"	14.08.050

LOAD LIMITING DEVICE

BDMN-010-LLCS

HYDRAULIC PRESSURE UNLOADING 3 WAYS

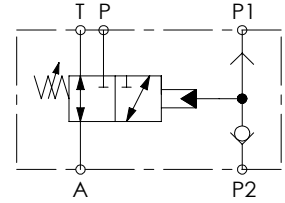
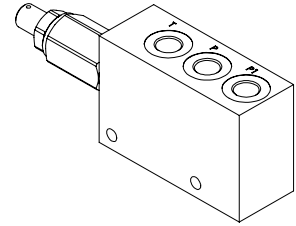
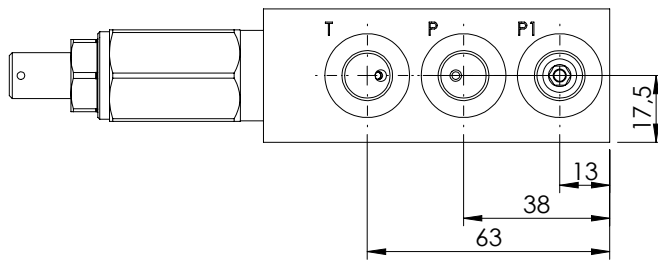
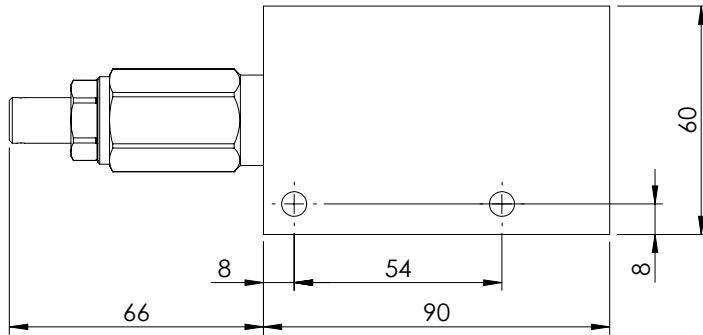
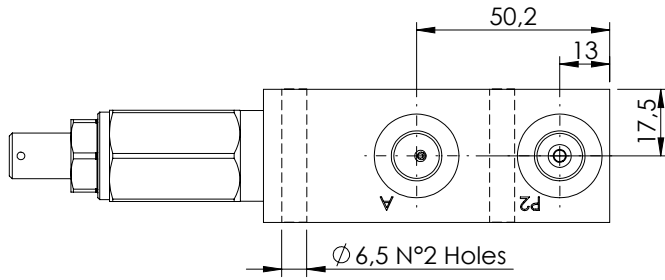

SPECIFICATIONS

Max. operating pressure:	210 bar
Rated flow:	8 l/min
Manifold:	Aluminium
Weight:	0,7 kg

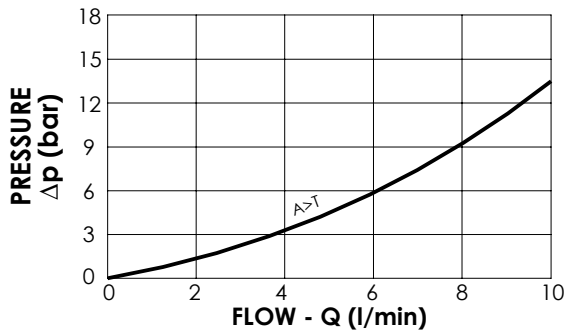

NOTES

ORDERING CODES

Quick code	Description	Main ports size	Standard setting (bar, Cracking Pr.)	Adjust. range (bar)	Pressure increase (bar/turn)
BD000104	BDMN-010-LLCS-NP-G14-N210	T,P,P1,A:G 1/4"	5	4-40	3

LOAD LIMITING DEVICE

MTTP-003-TLSN

**HYDRAULIC PRESSURE UNLOADING
2 WAYS**

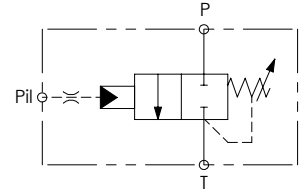
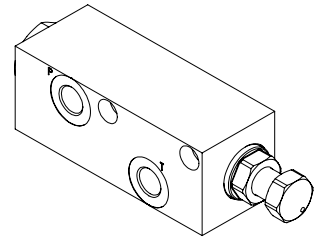

SPECIFICATIONS

Max. operating pressure:	350 bar
Rated flow:	3 l/min
Manifold:	Aluminium
Weight:	0,55 kg

NOTES

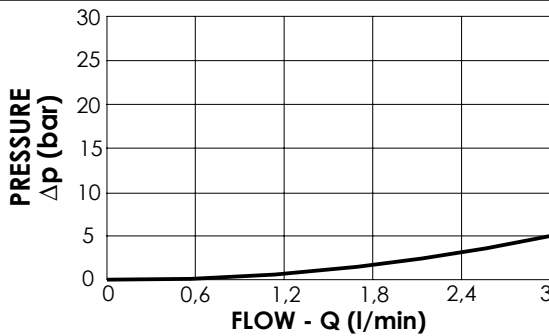
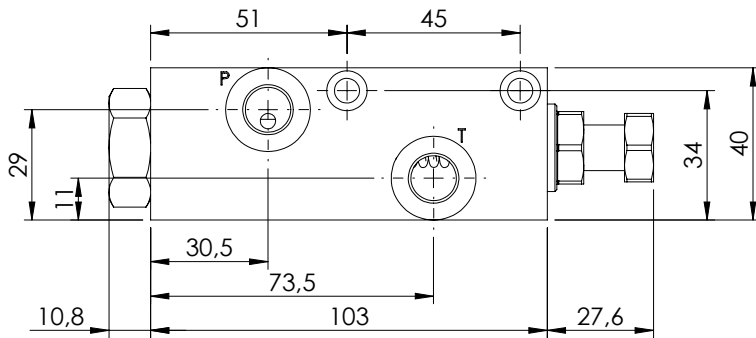
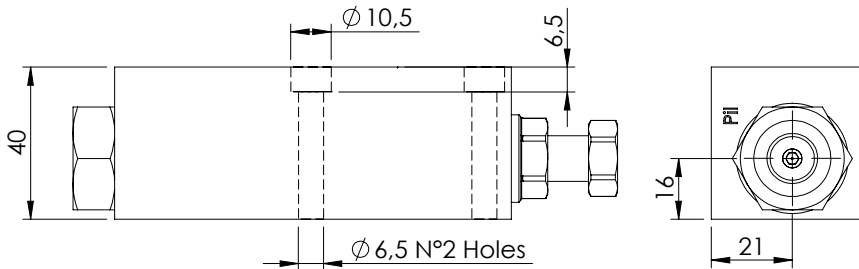

ORDERING CODES

Quick code	Description	Main ports size	Standard setting (bar, Q=5 l/min)	Adjust. range (bar)	Pressure increase (bar/turn)
MT000011	MTTP-003-TLSN-01-G14-N006	P, Pii, T: G1/4"	6	6-55	12

LOAD LIMITING DEVICE

MTSN-120-TLNR

HYDRAULIC PRESSURE
UNLOADING
KICK DOWN SYSTEM

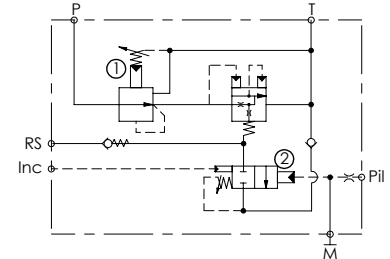
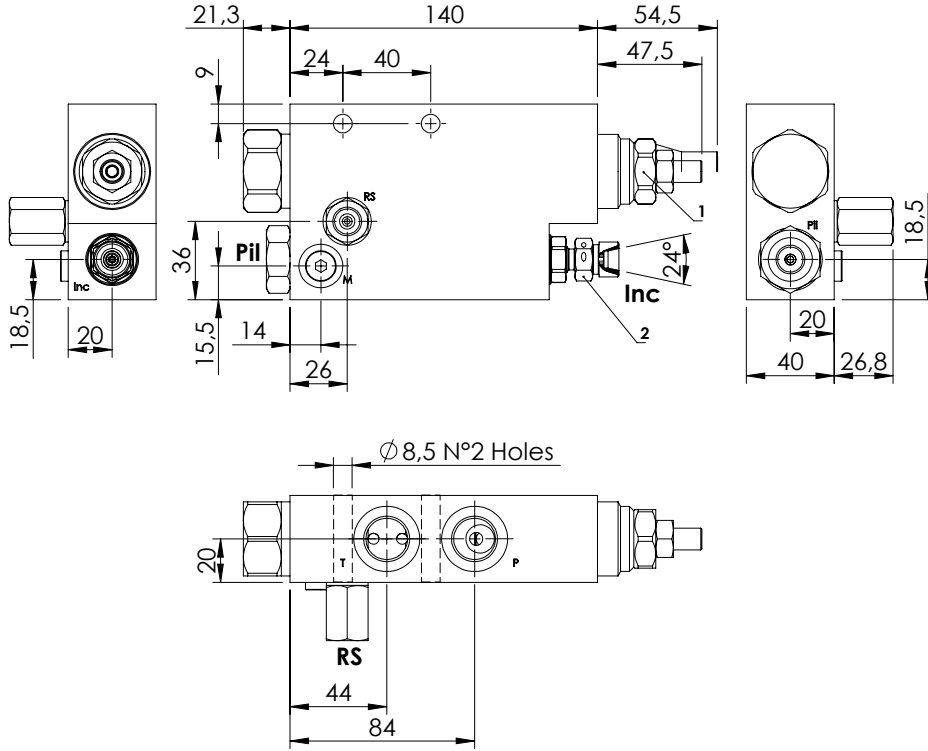
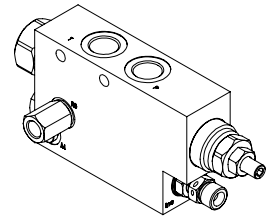

SPECIFICATIONS

Max. operating pressure:	350 bar
Rated flow:	120 l/min
Manifold:	Aluminium
Weight:	1,91 kg

SEALING CAP

Ordering cose:
AT000021

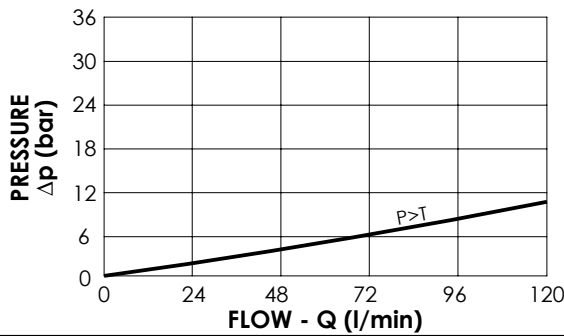
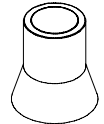

NOTES

ORDERING CODES

Quick code	Description	Main ports size	Standard setting (bar, Q=5 l/min)	Adjust. range (bar)	Pressure increase (bar/turn)
MT000010	MTSN-120-TLNR-NP-G12-N350	P,T:G 1/2" RS,Pil:G 1/4" Inc:M16x1,5 M:M10x1	① 35 ② 350	① 10-120 ② 70-210	① 37 ② 92

LOAD LIMITING DEVICE

MTTL-005-TLSN

PILOT PRESSURE UNLOADING

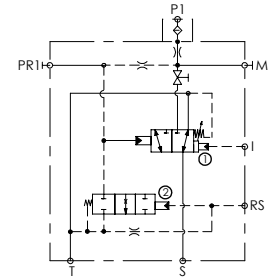
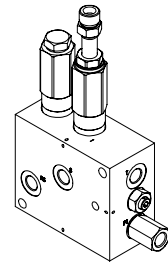
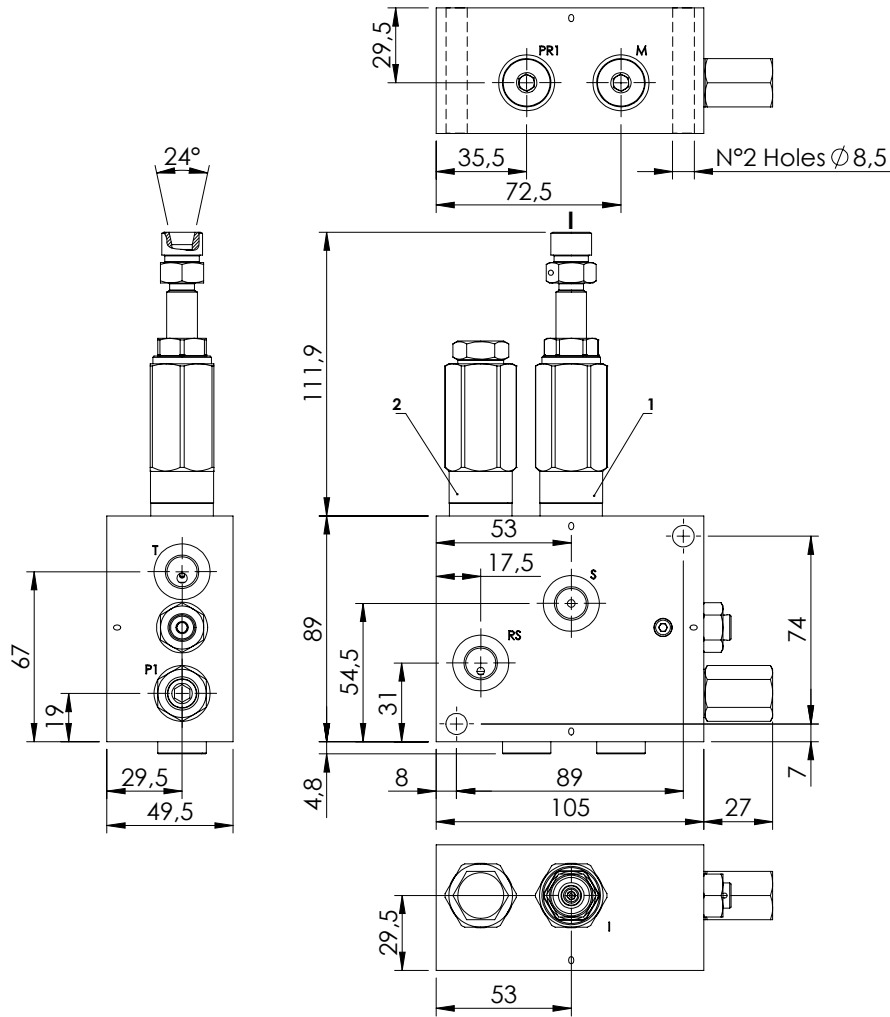

SPECIFICATIONS

Max. operating pressure:	350 bar
Rated flow:	5 l/min
Manifold:	Aluminium
Weight:	1,85 kg

NOTES

For info or special versions contact AFT sales network.

ORDERING CODES

Quick code	Description	Main ports size	Standard setting (bar, Q=5 l/min)	Adjust. range (bar)	Pressure increase (bar/turn)
MT000026	MTTL-005-TLSN-NP-G14-N350	P1,M,PR1,RS,T,S:G 1/4" I:M16x1,5	200	50-300	23

LOAD LIMITING DEVICE

MTR-005-TLSN

PILOT PRESSURE UNLOADING FLANGE FOR PRESSURE SWITCH

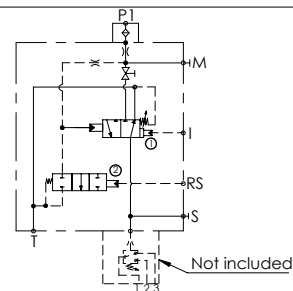
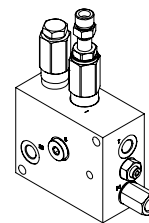

SPECIFICATIONS

Max. operating pressure:	350 bar
Rated flow:	5 l/min
Manifold:	Aluminium
Weight:	1,78 kg

NOTES

For info or special versions contact AFT sales network.

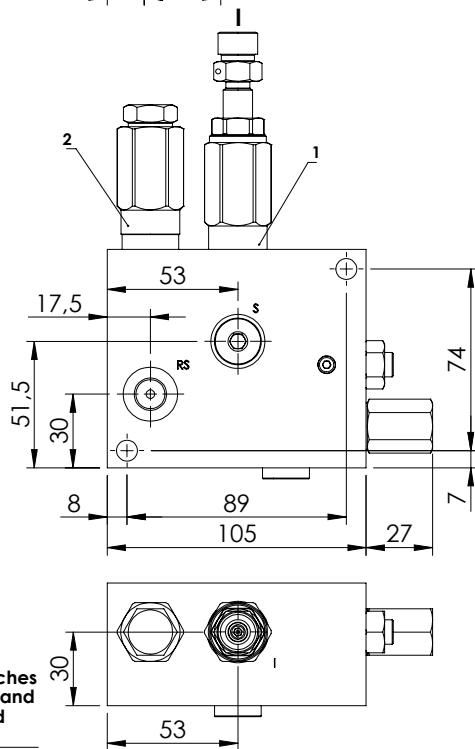
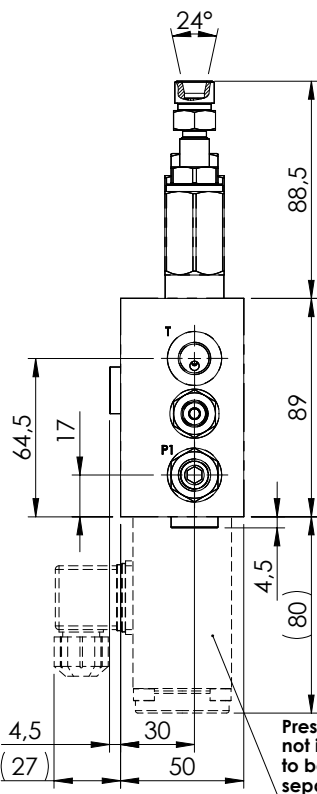
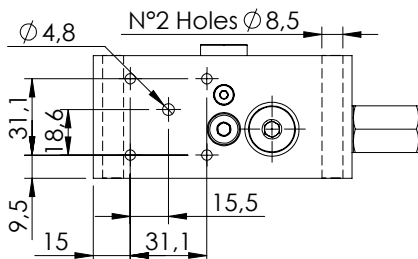

ORDERING CODES

Quick code	Description	Main ports size	Standard setting (bar, Q=5 l/min)	Adjust. range (bar)	Pressure increase (bar/turn)
MT000031	MTR-005-TLSN-NP-G14-N350	P1,M,PR1,RS,T,S:G 1/4" I:M16x1,5	280	100-350	109



ATLANTIC
Fluid Tech

SECTION 15

Solenoid
Cartridges



1800-OILSOL
1800-645765

<https://oilsolutions.com.au/>

sales@oilsolutions.com.au

SECTION 15

SOLENOID CARTRIDGES



Hydraulic scheme	Valve description	Valve type	Rated flow (l/min)	Max. pressure (bar)	Installation	Main port size or cavity type	Page
	CEBN-001-NCFN-15	Direct acting, poppet type	1,5	350/500	Cartridge	SAE-08-2N	15.01.010
	CEBD-001-NCFN-15	Direct acting, poppet type	1	350	Cartridge	VP000445	15.01.020
	CEBN-001-NCFN-16	Direct acting, poppet type	1,5	350/500	Cartridge	SAE-08-2N	15.02.030
	CEBD-001-NCFN-16	Direct acting, poppet type	1	350	Cartridge	VP000445	15.02.040
	CEBN-001-NAFN-13	Direct acting, poppet type	1,5	350/500	Cartridge	SAE-08-2N	15.03.050
	CEBD-001-NAFN-13	Direct acting, poppet type	1	350	Cartridge	VP000445	15.03.060
	CEBN-001-NAFN-14	Direct acting, poppet type	1,5	350/500	Cartridge	SAE-08-2N	15.04.070
	CEBD-001-NAFN-14	Direct acting, poppet type	1	350	Cartridge	VP000445	15.04.080
	CEBS-010-NCFN-22	Direct acting, spool type	10	210	Cartridge	SAE-08-2N	15.05.090
	CEBS-010-NAFN-23	Direct acting, spool type	10	210	Cartridge	SAE-08-2N	15.06.100
	CEBD-015-NCFN-21	Direct acting, poppet type	15	210	Cartridge	SAE-08-2N	15.07.110
	CEBP-020-NCFF-01	Pilot operated, poppet type, cable operated	20	250	Cartridge	SAE-08-2N	15.08.120
	CEBN-030-NCFN-01	Pilot operated, poppet type	30	350	Cartridge	SAE-08-2N	15.08.130
	CEBN-040-NCFN-01	Pilot operated, poppet type	40	350/500	Cartridge	SAE-08-2N	15.08.140
	CEBN-070-NCFN-01	Pilot operated, poppet type	70	350/500	Cartridge	SAE-10-2N	15.08.150
	CEBN-100-NCFN-01	Pilot operated, poppet type	100	350/500	Cartridge	VP000057	15.08.160
	CEBN-180-NCFN-01	Pilot operated, poppet type	180	350/500	Cartridge	SAE-12-2N	15.08.170
	CEBN-200-NCFN-01	Pilot operated, poppet type	200	350/500	Cartridge	VP000013	15.08.180
	CEBN-300-NCFN-01	Pilot operated, poppet type	300	350/500	Cartridge	SAE-16-2N	15.08.190
	CEBN-030-NCFN-05	Pilot operated, poppet type	30	350	Cartridge	SAE-08-2N	15.09.200
	CEBN-040-NCFN-05	Pilot operated, poppet type	40	350/500	Cartridge	SAE-08-2N	15.09.210
	CEBN-070-NCFN-05	Pilot operated, poppet type	70	350/500	Cartridge	SAE-10-2N	15.09.220
	CEBN-100-NCFN-05	Pilot operated, poppet type	100	350/500	Cartridge	VP000057	15.09.230
	CEBN-180-NCFN-05	Pilot operated, poppet type	180	350/500	Cartridge	SAE-12-2N	15.09.240
	CEBN-200-NCFN-05	Pilot operated, poppet type	200	350/500	Cartridge	VP000013	15.09.250
	CEBN-300-NCFN-05	Pilot operated, poppet type	300	350/500	Cartridge	SAE-16-2N	15.09.260
		CEBN-040-NCFN-03	Pilot operated, poppet type	40	350/500	Cartridge	SAE-08-2N
CEBN-070-NCFN-03		Pilot operated, poppet type	70	350/500	Cartridge	SAE-10-2N	15.10.280
CEBN-100-NCFN-03		Pilot operated, poppet type	100	350/500	Cartridge	VP000057	15.10.290
CEBN-200-NCFN-03		Pilot operated, poppet type	200	350/500	Cartridge	VP000013	15.10.300
CEBN-300-NCFN-03		Pilot operated, poppet type	300	350/500	Cartridge	SAE-16-2N	15.10.310
		CEBN-030-NAFN-02	Pilot operated, poppet type	30	350	Cartridge	SAE-08-2N
	CEBN-040-NAFN-02	Pilot operated, poppet type	40	350/500	Cartridge	SAE-08-2N	15.11.330
	CEBN-070-NAFN-02	Pilot operated, poppet type	70	350/500	Cartridge	SAE-10-2N	15.11.340
	CEBN-100-NAFN-02	Pilot operated, poppet type	100	350/500	Cartridge	VP000057	15.11.350
	CEBN-180-NAFN-02	Pilot operated, poppet type	180	350/500	Cartridge	SAE-12-2N	15.11.360
	CEBN-200-NAFN-02	Pilot operated, poppet type	200	350/500	Cartridge	VP000013	15.11.370
	CEBN-300-NAFN-02	Pilot operated, poppet type	300	350/500	Cartridge	SAE-16-2N	15.11.380
		CEBN-030-NAFN-06	Pilot operated, poppet type	30	350	Cartridge	SAE-08-2N
CEBN-040-NAFN-06		Pilot operated, poppet type	40	350/500	Cartridge	SAE-08-2N	15.12.400
CEBN-070-NAFN-06		Pilot operated, poppet type	70	350/500	Cartridge	SAE-10-2N	15.12.410
CEBN-100-NAFN-06		Pilot operated, poppet type	100	350/500	Cartridge	VP000057	15.12.420
CEBN-180-NAFN-06		Pilot operated, poppet type	180	350/500	Cartridge	SAE-12-2N	15.12.430
CEBN-200-NAFN-06		Pilot operated, poppet type	200	350/500	Cartridge	VP000013	15.12.440
CEBN-300-NAFN-06		Pilot operated, poppet type	300	350/500	Cartridge	SAE-16-2N	15.12.450

SECTION 15



SOLENOID CARTRIDGES

Hydraulic scheme	Valve description	Valve type	Rated flow (l/min)	Max. pressure (bar)	Installation	Main port size or cavity type	Page
	CEBN-040-NAFN-04	Pilot operated, poppet type	40	350/500	Cartridge	SAE-08-2N	15.13.460
	CEBN-070-NAFN-04	Pilot operated, poppet type	70	350/500	Cartridge	SAE-10-2N	15.13.470
	CEBN-100-NAFN-04	Pilot operated, poppet type	100	350/500	Cartridge	VP000057	15.13.480
	CEBN-200-NAFN-04	Pilot operated, poppet type	200	350/500	Cartridge	VP000013	15.13.490
	CEBN-300-NAFN-04	Pilot operated, poppet type	300	350/500	Cartridge	SAE-16-2N	15.13.500
	CEBN-040-NCFN-31	Pilot operated, poppet type	40	350/500	Cartridge	SAE-08-2N	15.14.510
	CEBN-070-NCFN-31	Pilot operated, poppet type	70	350/500	Cartridge	SAE-10-2N	15.14.520
	CEBN-100-NCFN-31	Pilot operated, poppet type	100	350/500	Cartridge	VP000057	15.14.530
	CEBN-180-NCFN-31	Pilot operated, poppet type	180	350/500	Cartridge	SAE-12-2N	15.14.540
	CEBN-200-NCFN-31	Pilot operated, poppet type	200	350/500	Cartridge	VP000013	15.14.550
CEBN-300-NCFN-31	Pilot operated, poppet type	300	350/500	Cartridge	SAE-16-2N	15.14.560	
	CEBN-040-NAFN-32	Pilot operated, poppet type	40	350/500	Cartridge	SAE-08-2N	15.15.570
	CEBN-070-NAFN-32	Pilot operated, poppet type	70	350/500	Cartridge	SAE-10-2N	15.15.580
	CEBN-100-NAFN-32	Pilot operated, poppet type	100	350/500	Cartridge	VP000057	15.15.590
	CEBN-180-NAFN-32	Pilot operated, poppet type	180	350/500	Cartridge	SAE-12-2N	15.15.600
	CEBN-200-NAFN-32	Pilot operated, poppet type	200	350/500	Cartridge	VP000013	15.15.610
CEBN-300-NAFN-32	Pilot operated, poppet type	300	350/500	Cartridge	SAE-16-2N	15.15.620	
	CEBN-040-NCDR-100	Pilot operated, proximity sensor	40	350	Cartridge	SAE-08-2N	15.16.630
	CEBN-070-NCDR-100	Pilot operated, proximity sensor	70	350	Cartridge	SAE-10-2N	15.16.640
	CEBN-100-NCDR-100	Pilot operated, proximity sensor	100	350	Cartridge	VP000057	15.16.650
	CEBN-180-NCDR-100	Pilot operated, proximity sensor	180	350	Cartridge	SAE-12-2N	15.16.660
	CEBN-200-NCDR-100	Pilot operated, proximity sensor	200	350	Cartridge	VP000013	15.16.670
CEBN-300-NCDR-100	Pilot operated, proximity sensor	300	350	Cartridge	SAE-16-2N	15.16.680	
	CEBN-040-NADR-101	Pilot operated, proximity sensor	40	350	Cartridge	SAE-08-2N	15.17.690
	CEBN-070-NADR-101	Pilot operated, proximity sensor	70	350	Cartridge	SAE-10-2N	15.17.700
	CEBN-100-NADR-101	Pilot operated, proximity sensor	100	350	Cartridge	VP000057	15.17.710
	CEBN-180-NADR-101	Pilot operated, proximity sensor	180	350	Cartridge	SAE-12-2N	15.17.720
	CEBN-200-NADR-101	Pilot operated, proximity sensor	200	350	Cartridge	VP000013	15.17.730
CEBN-300-NADR-101	Pilot operated, proximity sensor	300	350	Cartridge	SAE-16-2N	15.17.740	
	CEBN-040-NCDR-120	Pilot operated, proximity sensor	40	350	Cartridge	SAE-08-2N	15.18.750
	CEBN-070-NCDR-120	Pilot operated, proximity sensor	70	350	Cartridge	SAE-10-2N	15.18.760
	CEBN-100-NCDR-120	Pilot operated, proximity sensor	100	350	Cartridge	VP000057	15.18.770
	CEBN-180-NCDR-120	Pilot operated, proximity sensor	180	350	Cartridge	SAE-12-2N	15.18.780
	CEBN-200-NCDR-120	Pilot operated, proximity sensor	200	350	Cartridge	VP000013	15.18.790
CEBN-300-NCDR-120	Pilot operated, proximity sensor	300	350	Cartridge	SAE-16-2N	15.18.800	
	CEBN-040-NCDR-121	Pilot operated, proximity sensor	40	350	Cartridge	SAE-08-2N	15.19.810
	CEBN-070-NCDR-121	Pilot operated, proximity sensor	70	350	Cartridge	SAE-10-2N	15.19.820
	CEBN-100-NCDR-121	Pilot operated, proximity sensor	100	350	Cartridge	VP000057	15.19.830
	CEBN-180-NCDR-121	Pilot operated, proximity sensor	180	350	Cartridge	SAE-12-2N	15.19.840
	CEBN-200-NCDR-121	Pilot operated, proximity sensor	200	350	Cartridge	VP000013	15.19.850
CEBN-300-NCDR-121	Pilot operated, proximity sensor	300	350	Cartridge	SAE-16-2N	15.19.860	
	CEBD-040-NAMV	Direct acting, poppet type	40	350	Cartridge	VP000338	15.20.870
	CEBD-040-NACV						
	CEBT-300-NCFN-98	Piloted operated, spool type	300	350	Cartridge	SAE-16-2N	15.21.880
	CEBT-500-NCFN-98	Piloted operated, spool type	500	350	Cartridge	SAE-20-2N	15.21.890
	CEBT-300-NAFN-99	Piloted operated, spool type	300	350	Cartridge	SAE-16-2N	15.22.900
	CEBT-500-NAFN-99	Piloted operated, spool type	500	350	Cartridge	SAE-20-2N	15.22.910
	CEBN-040-NCAN-05	Pneumatic operated, poppet type	40	350	Cartridge	SAE-08-2N	15.23.920
	CEBN-200-NCAN-05	Pneumatic operated, poppet type	200	350	Cartridge	VP000013	15.23.930
	CECS-010-SEFN-61	Direct acting, spool type	10	210	Cartridge	SAE-08-3N	15.24.940

SECTION 15



SOLENOID CARTRIDGES

Hydraulic scheme	Valve description	Valve type	Rated flow (l/min)	Max. pressure (bar)	Installation	Main port size or cavity type	Page
	CECS-010-SEFN-62	Direct acting, spool type	10	210	Cartridge	SAE-08-3N	15.25.950
	CECS-010-SEFN-63	Direct acting, spool type	10	210	Cartridge	SAE-08-3N	15.26.960
	CECS-010-SEFN-64	Direct acting, spool type	10	210	Cartridge	SAE-08-3N	15.27.970
	CEDS-010-SEFN-40	Direct acting, spool type	10	210	Cartridge	SAE-08-4N	15.28.980
	CEDS-010-SEFN-49	Direct acting, spool type	10	210	Cartridge	SAE-08-4N	15.29.990
	CEDS-010-SEFN-41	Direct acting, spool type	10	210	Cartridge	SAE-08-4N	15.30.1000
	CEDS-010-SEFN-43	Direct acting, spool type	10	210	Cartridge	SAE-08-4N	15.31.1010
	CEES-010-SEFN-51	Direct acting, spool type	10	210	Cartridge	SAE-08-4N	15.32.1020
	CEES-010-SEFN-52	Direct acting, spool type	10	210	Cartridge	SAE-08-4N	15.33.1030
	CEES-010-SEFN-53	Direct acting, spool type	10	210	Cartridge	SAE-08-4N	15.34.1040
	CEES-010-SEFN-54	Direct acting, spool type	10	210	Cartridge	SAE-08-4N	15.35.1050

SOLENOID OPERATED CARTRIDGE

CEBD-001-NCFN

**DIRECT OPERATED
POPPET TYPE**

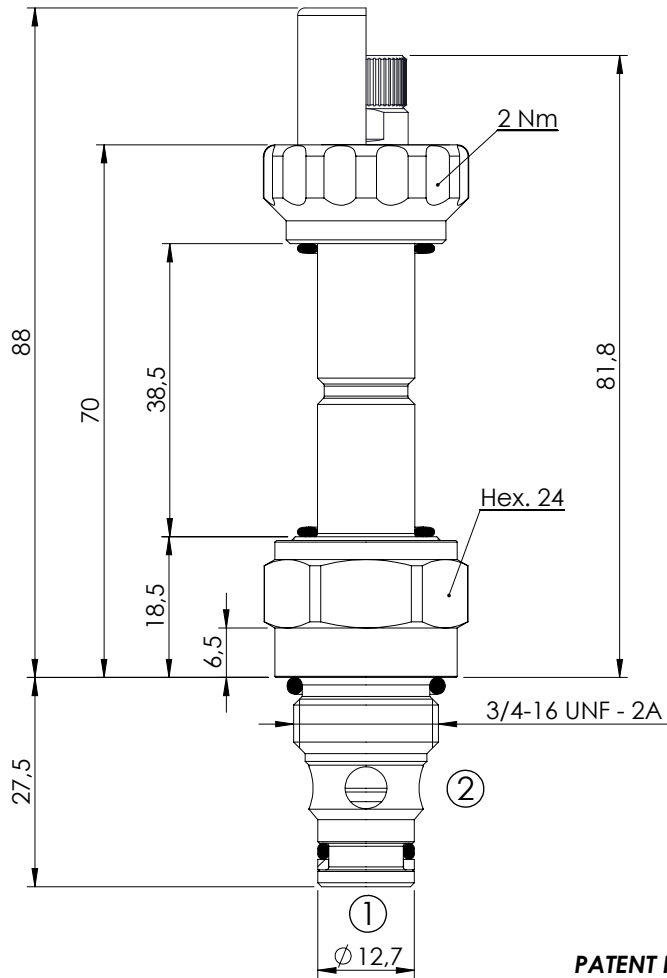

PATENT PENDING

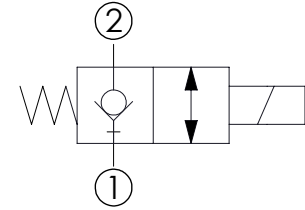
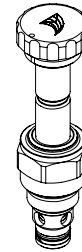

SPECIFICATIONS

Max. operating pressure:	350/500 bar
Rated flow:	1,5 l/min
Cavity:	SAE-08-2N
Weight:	0,14 kg
Min. voltage required:	90% of nominal
Coil type:	M7 type
Seal kit:	RA900081

NOTES

Installation torque: 45 - 50 Nm

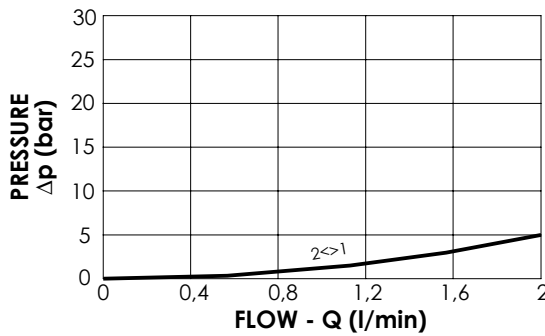

OPTIONS

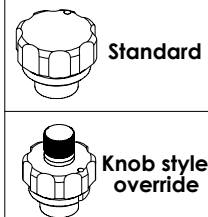

SEALING CAP

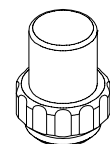

Ordering code:
AT000113

ORDERING CODES

Quick code	Description	Options	Max operating pressure (bar)
CE000200	CEBD-001-NCFN-15-S08-N350	Standard	350
CE000201	CEBD-001-NCFK-15-S08-N350	Knob style override	350
CE000500	CEBD-001-NCFN-15-S08-N500	Standard	500
CE000501	CEBD-001-NCFK-15-S08-N500	Knob style override	500

SOLENOID OPERATED CARTRIDGE

CEBN-001-NCFN

**DIRECT OPERATED
POPPET TYPE**

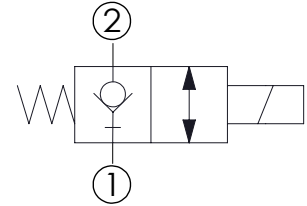
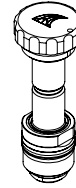
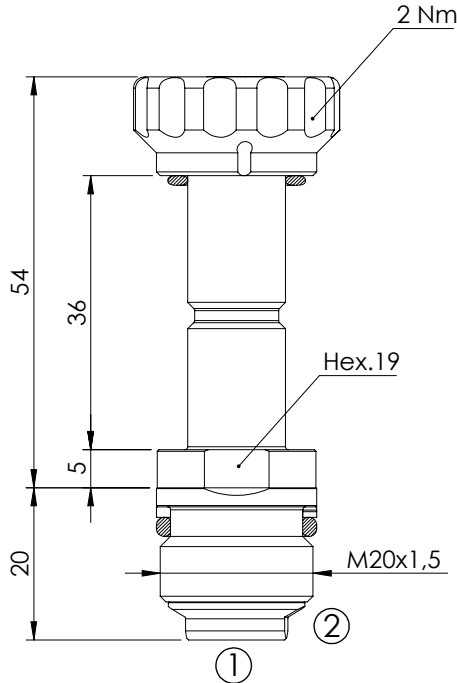

SPECIFICATIONS

Max. operating pressure:	350 bar
Rated flow:	1 l/min
Cavity:	VP000445
Weight:	0,1 kg
Min. voltage required:	90% of nominal
Coil type:	M7 type
Seal kit:	RC700445

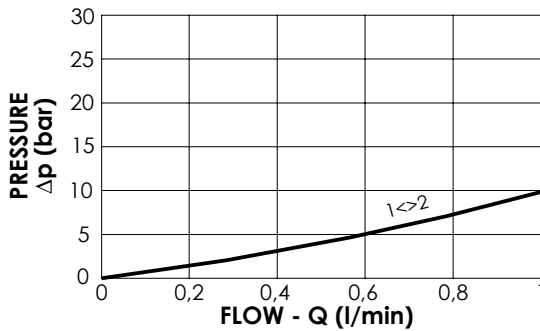

NOTES

Installation torque: 40 - 45 Nm

ORDERING CODES

Quick code	Description	Max operating pressure (bar)	
CE000870	CEBN-001-NCFN-15-445-N350	350	

SOLENOID OPERATED CARTRIDGE

CEBD-001-NCFN

**DIRECT OPERATED
POPPET TYPE**

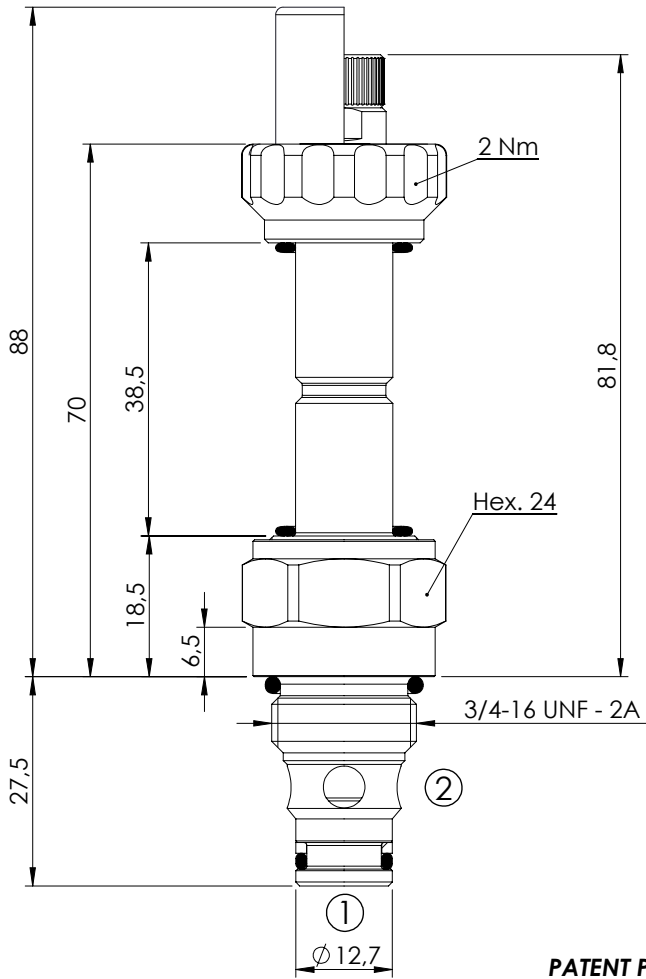

PATENT PENDING

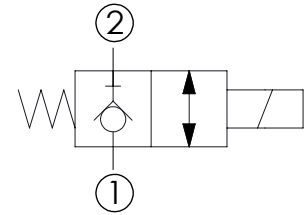
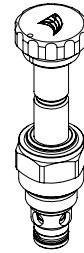

SPECIFICATIONS

Max. operating pressure:	350/500 bar
Rated flow:	1,5 l/min
Cavity:	SAE-08-2N
Weight:	0,14 kg
Min. voltage required:	90% of nominal
Coil type:	M7 type
Seal kit:	RA900081

NOTES

Installation torque: 45 - 50 Nm

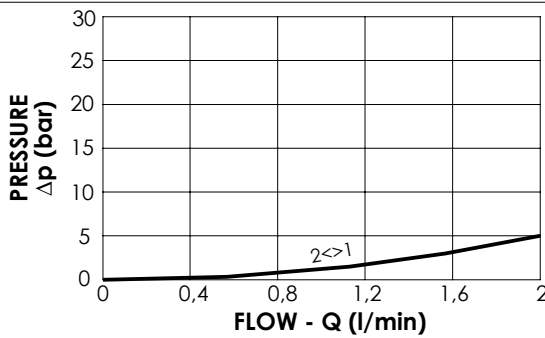

OPTIONS SEALING CAP

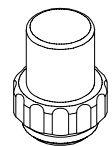

Ordering code:
AT000113

ORDERING CODES

Quick code	Description	Options	Max operating pressure (bar)
CE000202	CEBD-001-NCFN-16-S08-N350	Standard	350
CE000203	CEBD-001-NCFK-16-S08-N350	Knob style override	350
CE000502	CEBD-001-NCFN-16-S08-N500	Standard	500
CE000503	CEBD-001-NCFK-16-S08-N500	Knob style override	500

SOLENOID OPERATED CARTRIDGE

CEBN-001-NCFN

**DIRECT OPERATED
POPPET TYPE**

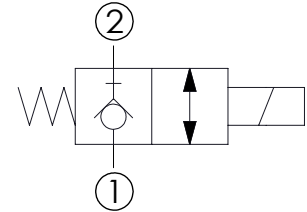
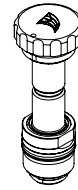
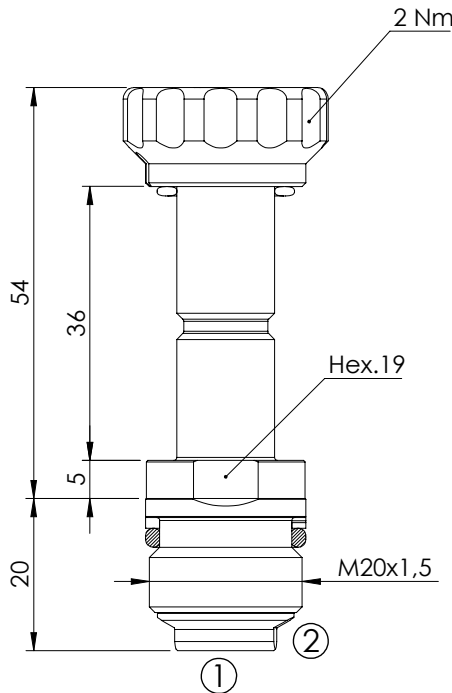

SPECIFICATIONS

Max. operating pressure:	350 bar
Rated flow:	1 l/min
Cavity:	VP000445
Weight:	0,1 kg
Min. voltage required:	90% of nominal
Coil type:	M7 type
Seal kit:	RC700445

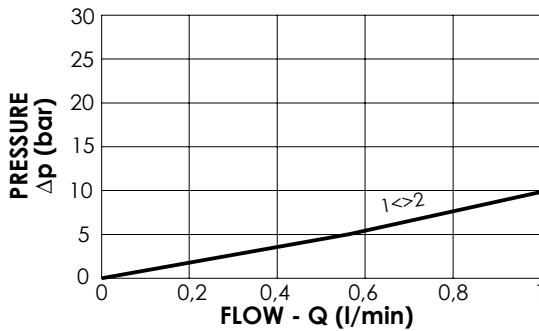

NOTES

Installation torque: **40 - 45 Nm**

ORDERING CODES

Quick code	Description	Max operating pressure (bar)	
CE000871	CEBN-001-NCFN-16-445-N350	350	

SOLENOID OPERATED CARTRIDGE

CEBD-001-NAFN

**DIRECT OPERATED
POPPET TYPE**

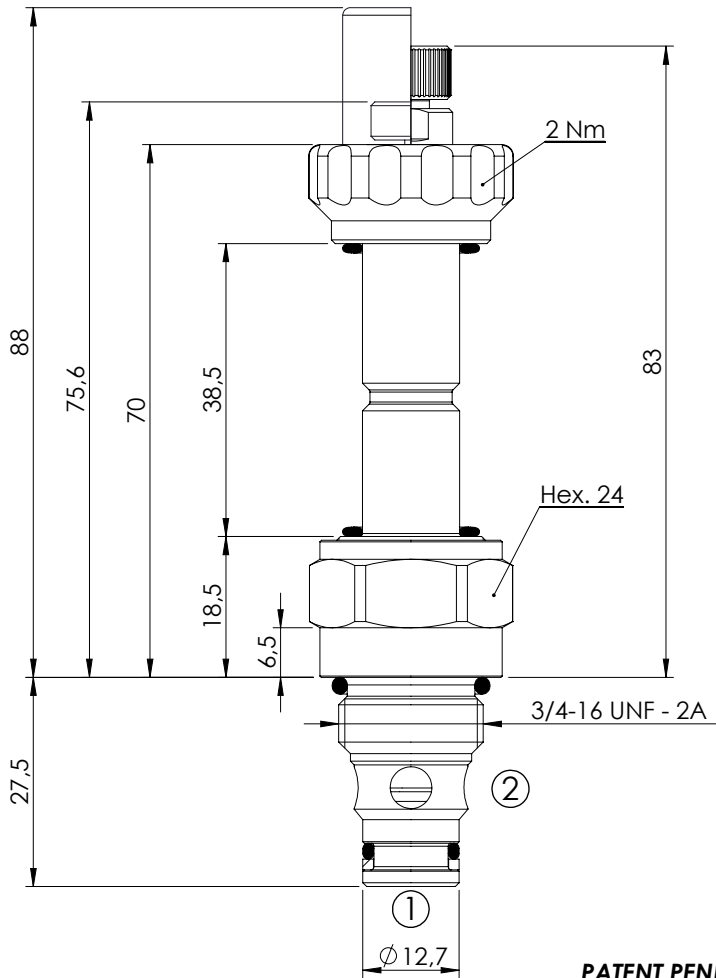

PATENT PENDING

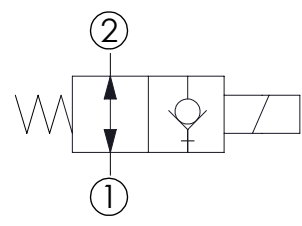
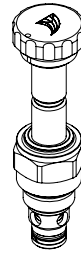

SPECIFICATIONS

Max. operating pressure:	350/500 bar
Rated flow:	1,5 l/min
Cavity:	SAE-08-2N
Weight:	0,14 kg
Min. voltage required:	90% of nominal
Coil type:	M7 type
Seal kit:	RA900081

NOTES

Installation torque: 45 - 50 Nm

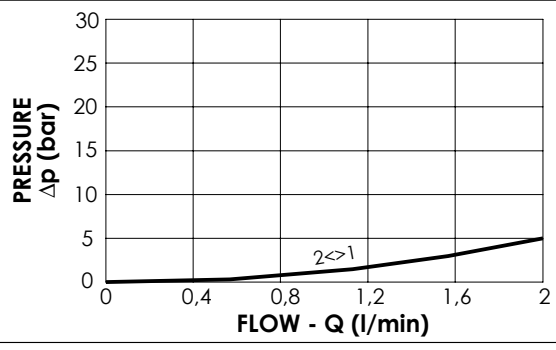

OPTIONS SEALING CAP

- Standard
- Push style override
- Knob style override

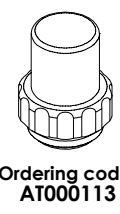

Ordering code: AT000113

ORDERING CODES

Quick code	Description	Options	Max operating pressure (bar)
CE000204	CEBD-001-NAFN-13-S08-N350	Standard	350
CE000205	CEBD-001-NAFP-13-S08-N350	Push style override	350
CE000206	CEBD-001-NAFK-13-S08-N350	Knob style override	350
CE000504	CEBD-001-NAFN-13-S08-N500	Standard	500
CE000505	CEBD-001-NAFP-13-S08-N500	Push style override	500
CE000506	CEBD-001-NAFK-13-S08-N500	Knob style override	500



SOLENOID OPERATED CARTRIDGE

CEBN-001-NAFN

**DIRECT OPERATED
POPPET TYPE**

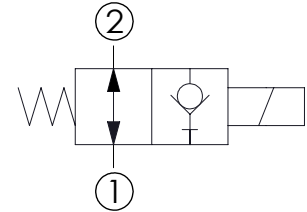
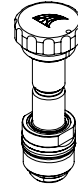
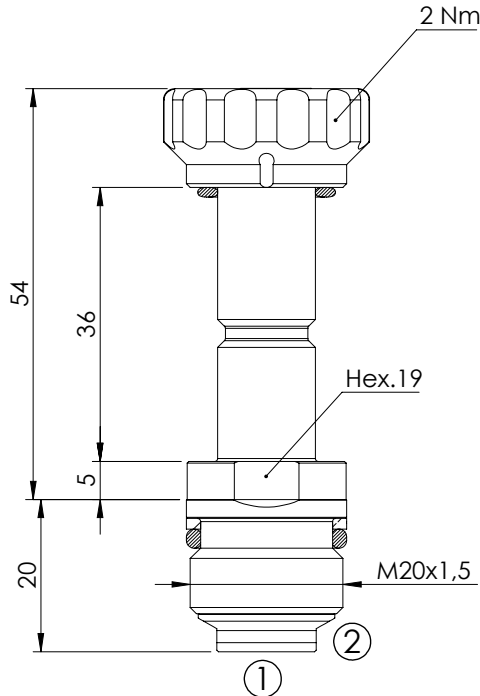

SPECIFICATIONS

Max. operating pressure:	350 bar
Rated flow:	1 l/min
Cavity:	VP000445
Weight:	0,1 kg
Min. voltage required:	90% of nominal
Coil type:	M7 type
Seal kit:	RC700445

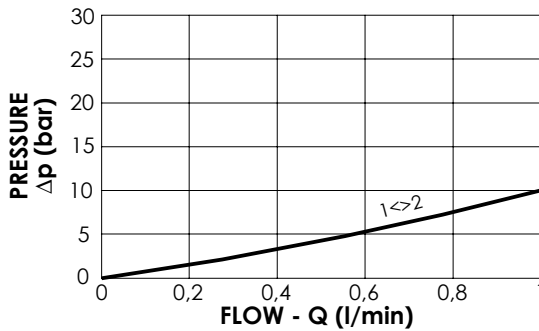

NOTES

Installation torque: 40 - 45 Nm

ORDERING CODES

Quick code	Description	Max operating pressure (bar)	
CE000872	CEBN-001-NAFN-13-445-N350	350	

SOLENOID OPERATED CARTRIDGE

CEBD-001-NAFN

**DIRECT OPERATED
POPPET TYPE**

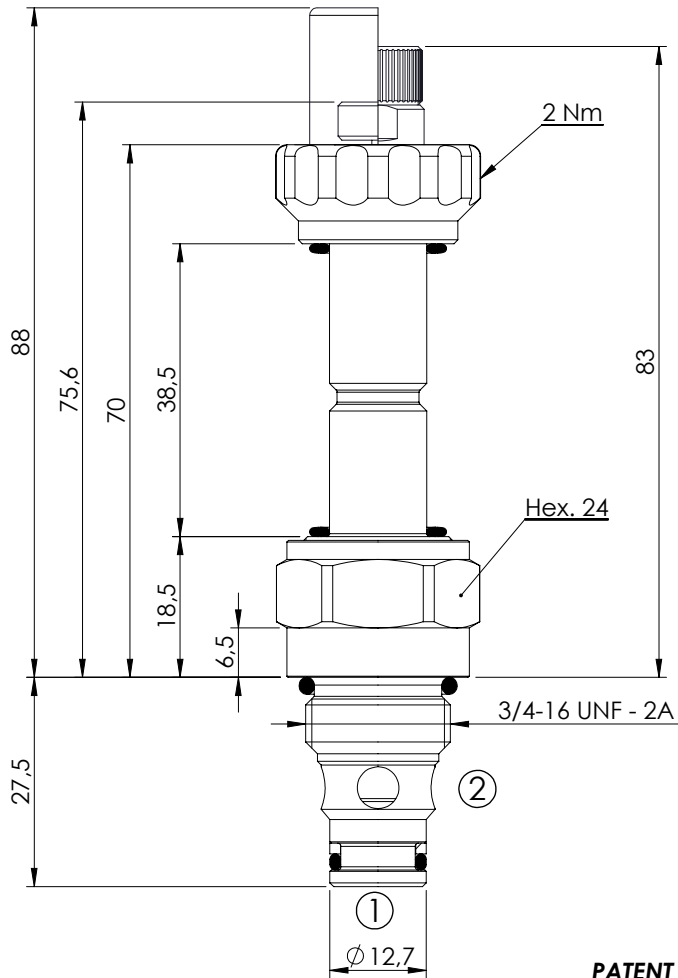

PATENT PENDING

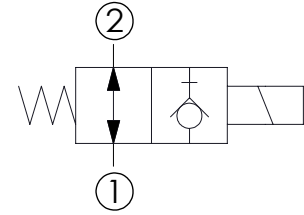
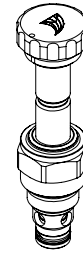

SPECIFICATIONS

Max. operating pressure:	350/500 bar
Rated flow:	1,5 l/min
Cavity:	SAE-08-2N
Weight:	0,15 kg
Min. voltage required:	90% of nominal
Coil type:	M7 type
Seal kit:	RA900081

NOTES

Installation torque: 45 - 50 Nm

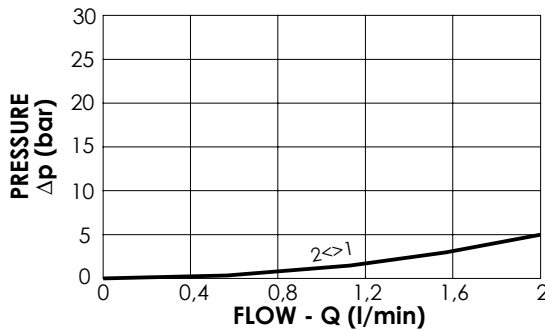

OPTIONS

- Standard
- Push style override
- Knob style override

SEALING CAP

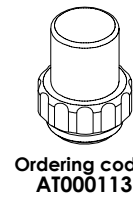

Ordering code:
AT000113

ORDERING CODES

Quick code	Description	Options	Max operating pressure (bar)
CE000207	CEBD-001-NAFN-14-S08-N350	Standard	350
CE000208	CEBD-001-NAFP-14-S08-N350	Push style override	350
CE000209	CEBD-001-NAFK-14-S08-N350	Knob style override	350
CE000507	CEBD-001-NAFN-14-S08-N500	Standard	500
CE000508	CEBD-001-NAFP-14-S08-N500	Push style override	500
CE000509	CEBD-001-NAFK-14-S08-N500	Knob style override	500

SOLENOID OPERATED CARTRIDGE

CEBN-001-NAFN

**DIRECT OPERATED
POPPET TYPE**

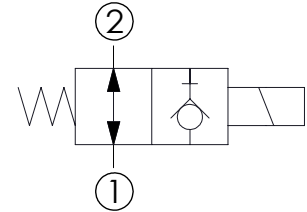
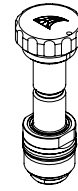
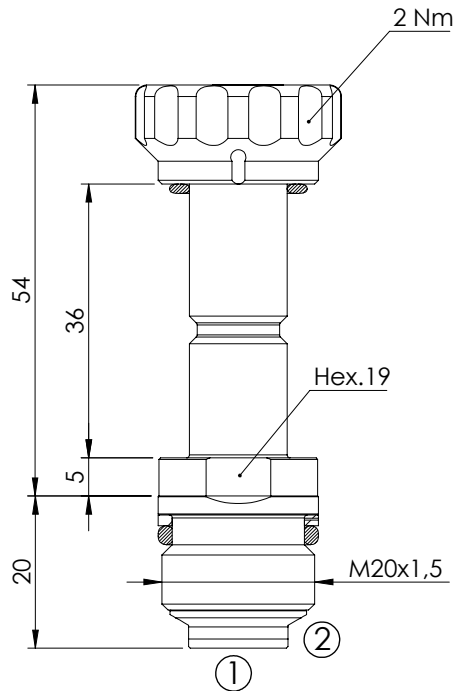

SPECIFICATIONS

Max. operating pressure:	350 bar
Rated flow:	1 l/min
Cavity:	VP000445
Weight:	0,1 kg
Min. voltage required:	90% of nominal
Coil type:	M7 type
Seal kit:	RC700445

NOTES

Installation torque:	40 - 45 Nm
----------------------	------------

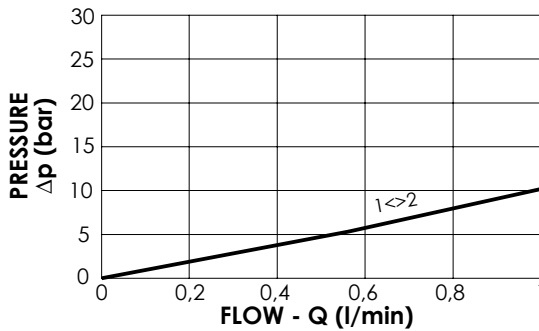

ORDERING CODES

Quick code	Description	Max operating pressure (bar)	
CE000873	CEBN-001-NAFN-14-445-N350	350	

SOLENOID OPERATED CARTRIDGE

CEBS-010-NCFN

**DIRECT OPERATED
SPOOL TYPE**

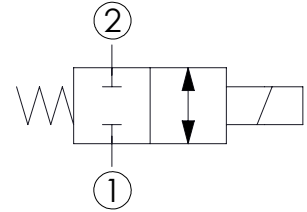
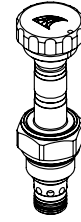
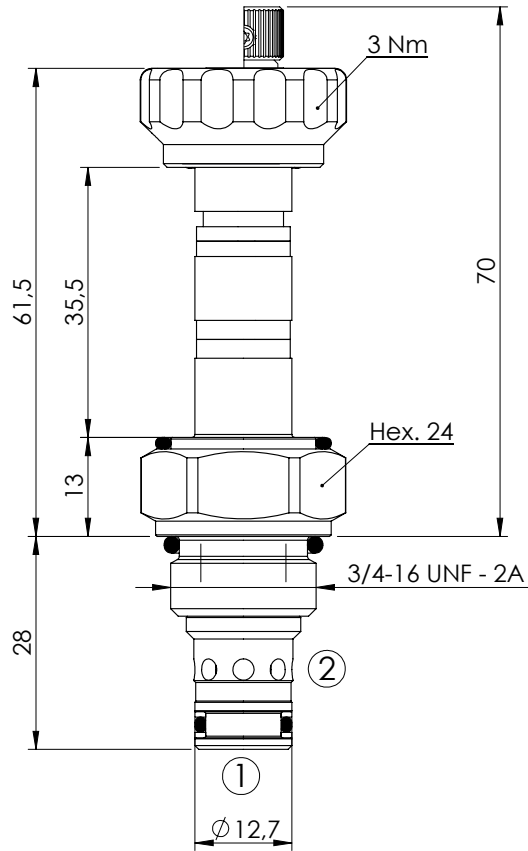

SPECIFICATIONS

Max. operating pressure:	210 bar
Rated flow:	10 l/min
Cavity:	SAE-08-2N
Weight:	0,12 kg
Min. voltage required:	90% of nominal
Coil type:	M7 type
Seal kit:	RB700081

NOTES

Installation torque: 45 - 50 Nm

OPTIONS

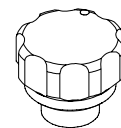

Standard

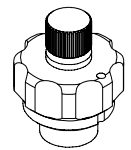

Knob style
override

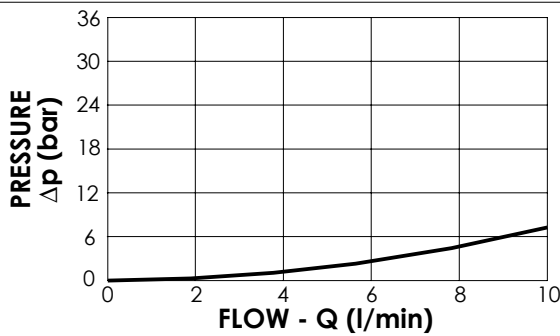

ORDERING CODES

Quick code	Description	Options	
CE000092	CEBS-010-NCFN-22-S08-N210	Standard	
CE000093	CEBS-010-NCFE-22-S08-N210	Knob style override	

SOLENOID OPERATED CARTRIDGE



CEBS-010-NAFN

**DIRECT OPERATED
SPOOL TYPE**

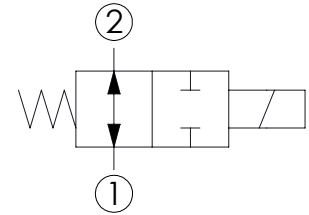
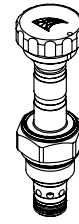
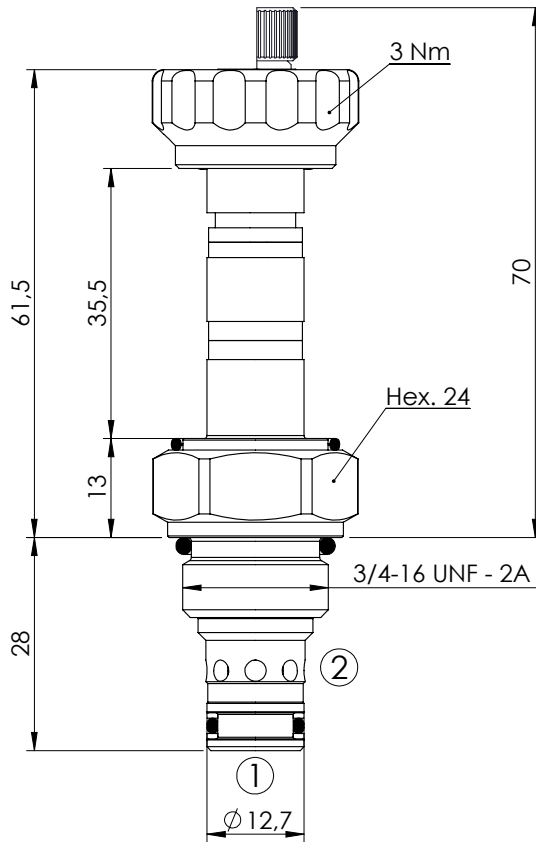

SPECIFICATIONS

Max. operating pressure:	210 bar
Rated flow:	10 l/min
Cavity:	SAE-08-2N
Weight:	0,12 kg
Min. voltage required:	90% of nominal
Coil type:	M7 type
Seal kit:	RB700081

NOTES

Installation torque: 45 - 50 Nm

OPTIONS

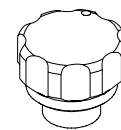

Standard

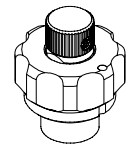

Knob style
override

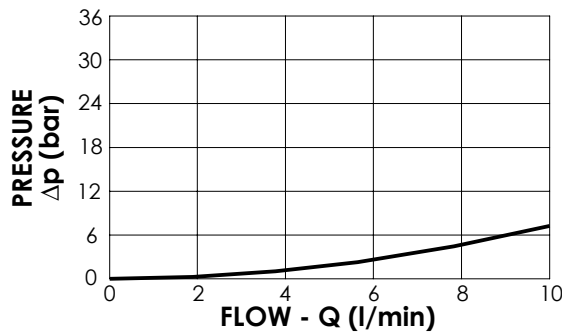

ORDERING CODES

Quick code	Description	Options	
CE000090	CEBS-010-NAFN-23-S08-N210	Standard	
CE000091	CEBS-010-NAFE-23-S08-N210	Knob style override	

SOLENOID OPERATED CARTRIDGE

CEBD-015-NCFN

**DIRECT OPERATED
POPPET TYPE**

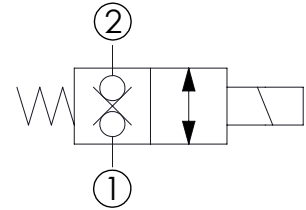
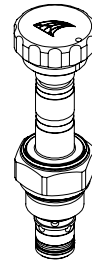
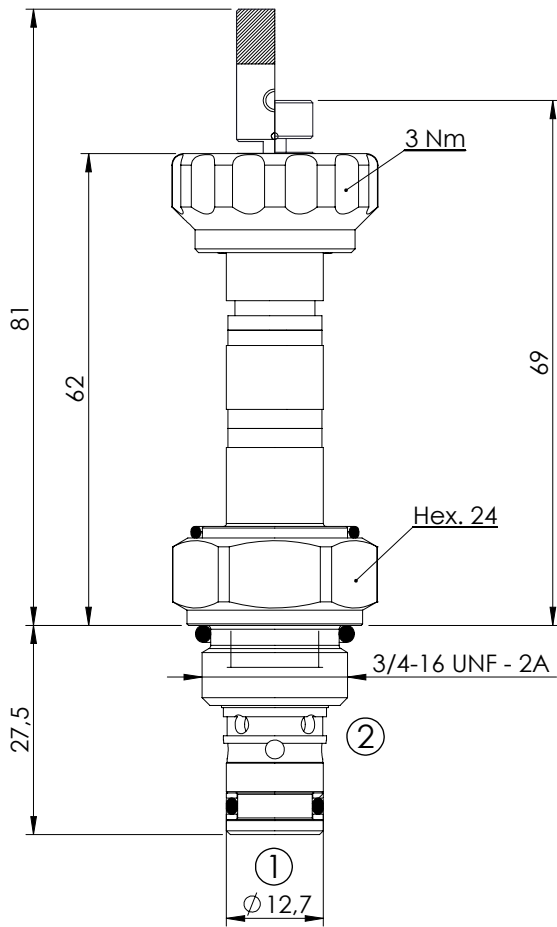

SPECIFICATIONS

Max. operating pressure:	210 bar
Rated flow:	15 l/min
Cavity:	SAE-08-2N
Weight:	0,12 kg
Min. voltage required:	90% of nominal
Coil type:	M7 type
Seal kit:	RB700081

NOTES

Installation torque: **45 - 50 Nm**

OPTIONS

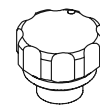

Standard

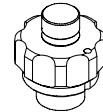

Push style
override

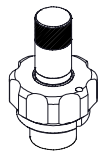

Push and twist
style override

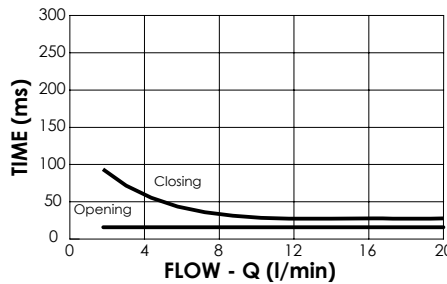
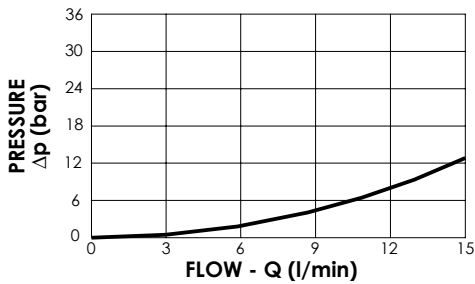

ORDERING CODES

Quick code	Description	Options	
CE000062	CEBD-015-NCFN-21-S08-N210	Standard	
CE000063	CEBD-015-NCFE-21-S08-N210	Push style override	
CE000905	CEBD-015-NCFE-21-S08-N210-T	Push and twist style override	

SOLENOID OPERATED CARTRIDGE

CEBN-040-NCFF

**PILOT OPERATED
POPPET TYPE**

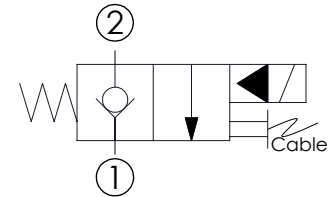
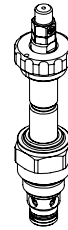
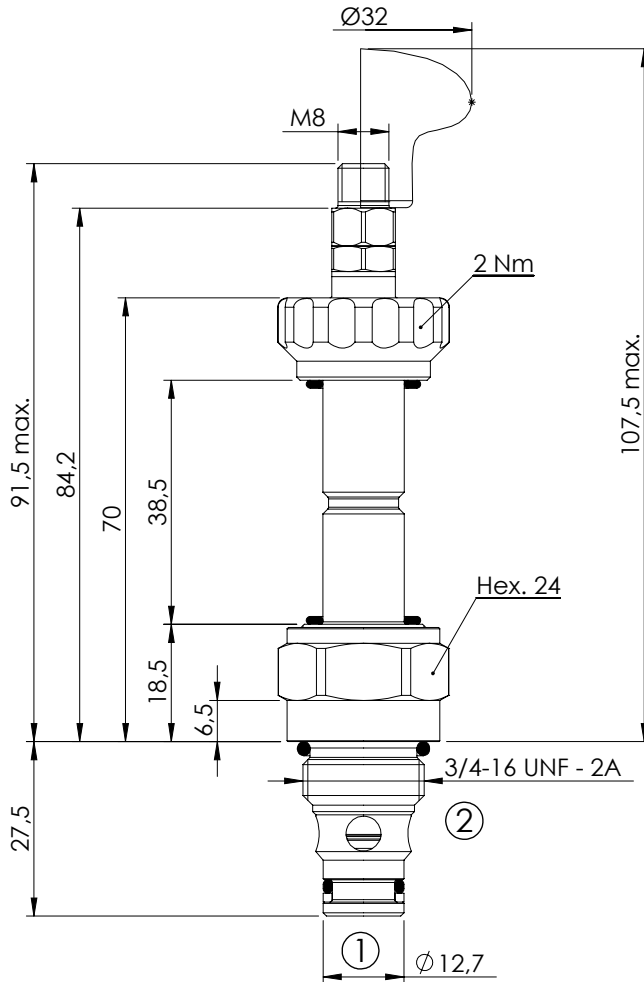

SPECIFICATIONS

Max. operating pressure:	350 bar
Rated flow:	40 l/min
Cavity:	SAE-08-2N
Weight:	0,16 kg
Min. voltage required:	90% of nominal
Coil type:	M7 type
Seal kit:	RA900081

NOTES

Installation torque: 45 - 50 Nm

OPTIONS

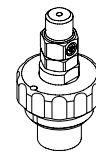

Cable Operated

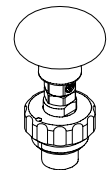

Hand Operated

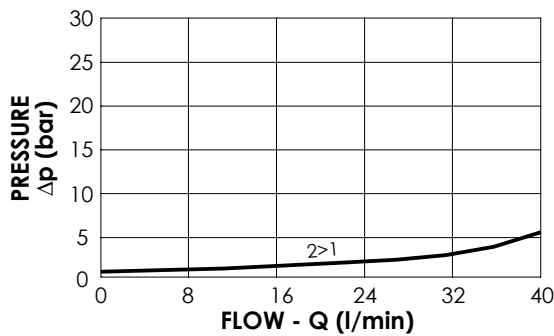

ORDERING CODES

Quick code	Description	Options		
CE000470	CEBN-040-NCFF-01-S08-N350	Cable Operated		
CE000799	CEBN-040-NCFM-01-S08-N350	Hand Operated		

SOLENOID OPERATED CARTRIDGE

CEBN-030-NCFN

**PILOT OPERATED
POPPET TYPE**

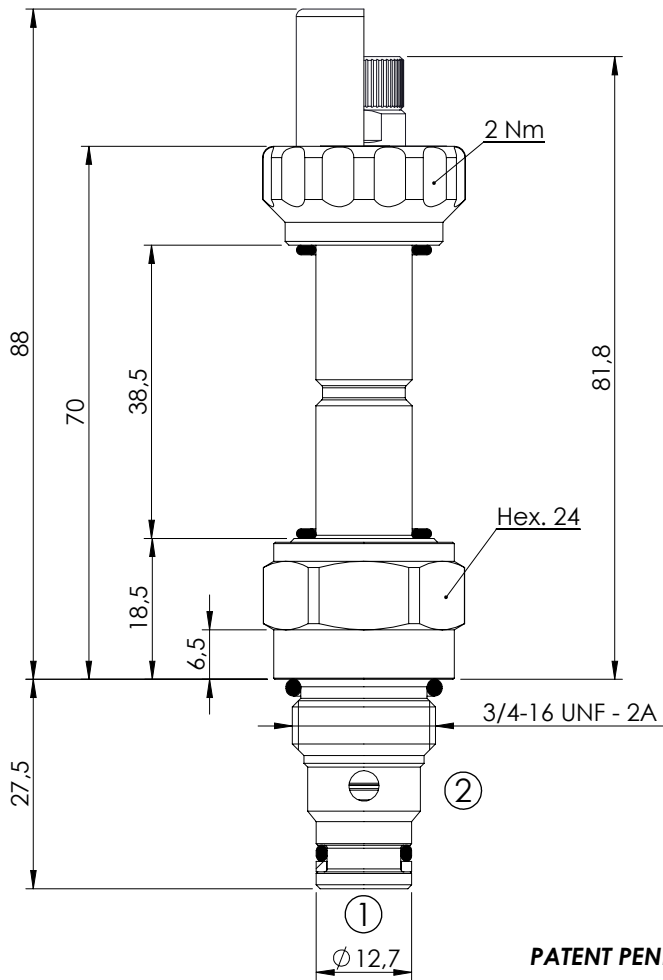

PATENT PENDING

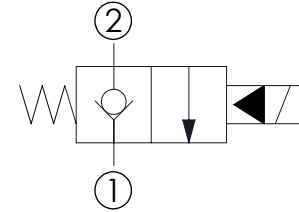
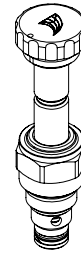

SPECIFICATIONS

Max. operating pressure:	350 bar
Rated flow:	30 l/min
Cavity:	SAE-08-2N
Weight:	0,15 kg
Min. voltage required:	90% of nominal
Coil type:	M7 type
Seal kit:	RA900081

NOTES

Installation torque: 45 - 50 Nm

OPTIONS

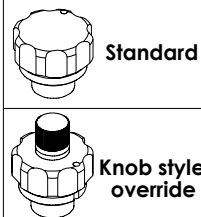

SEALING CAP

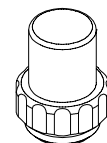

Ordering code:
AT000113

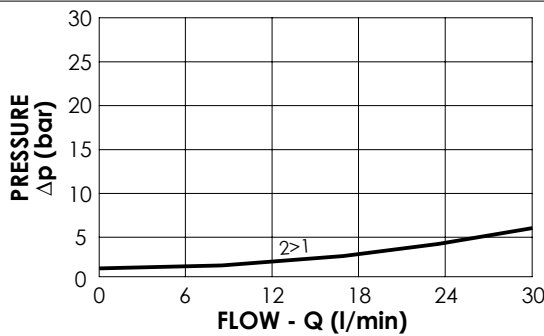

ORDERING CODES

Quick code	Description	Options	Max operating pressure (bar)
CE000455	CEBN-030-NCFN-01-S08-N350	Standard	350
CE000456	CEBN-030-NCFK-01-S08-N350	Knob style override	350

SOLENOID OPERATED CARTRIDGE

CEBN-040-NCFN

**PILOT OPERATED
POPPET TYPE**

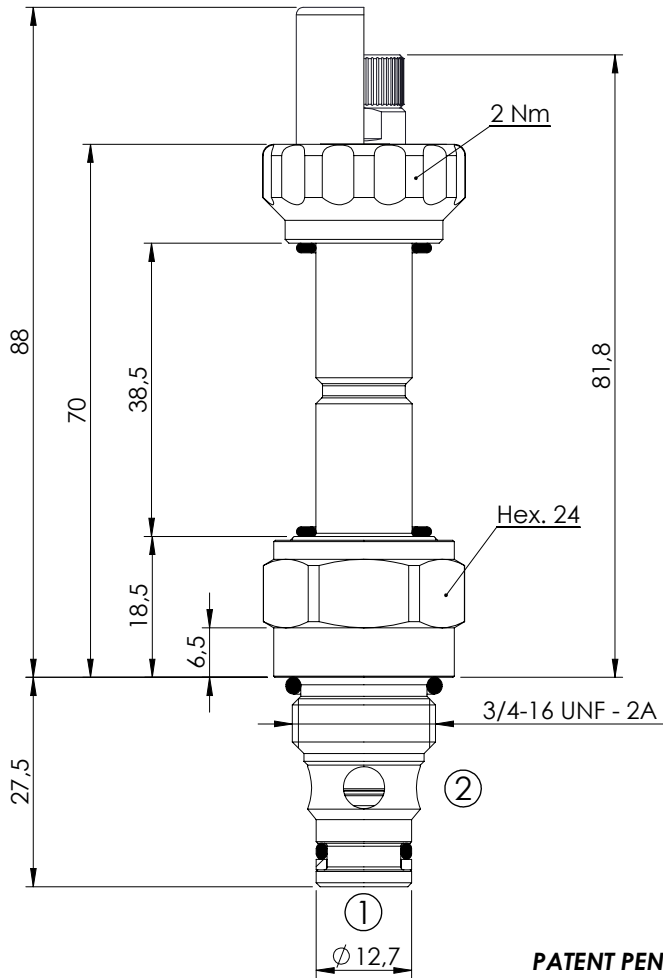

PATENT PENDING

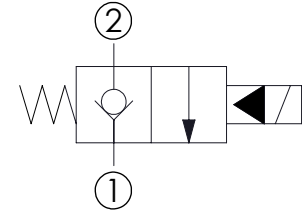
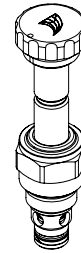

SPECIFICATIONS

Max. operating pressure:	350/500 bar
Rated flow:	40 l/min
Cavity:	SAE-08-2N
Weight:	0,14 kg
Min. voltage required:	90% of nominal
Coil type:	M7 type
Seal kit:	RA900081

NOTES

Installation torque: 45 - 50 Nm

OPTIONS

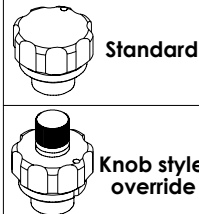

SEALING CAP

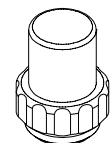

Ordering code:
AT000113

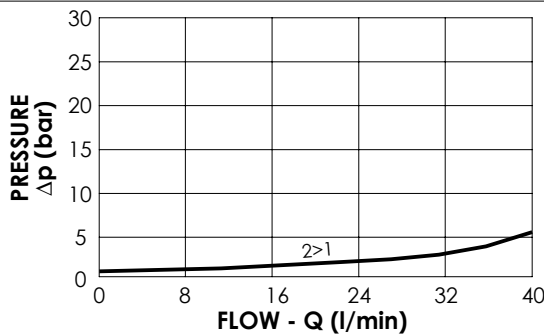

ORDERING CODES

Quick code	Description	Options	Max operating pressure (bar)
CE000210	CEBN-040-NCFN-01-S08-N350	Standard	350
CE000212	CEBN-040-NCFK-01-S08-N350	Knob style override	350
CE000510	CEBN-040-NCFN-01-S08-N500	Standard	500
CE000512	CEBN-040-NCFK-01-S08-N500	Knob style override	500

SOLENOID OPERATED CARTRIDGE

CEBN-070-NCFN

**PILOT OPERATED
POPPET TYPE**

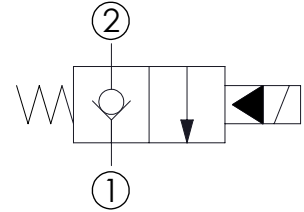
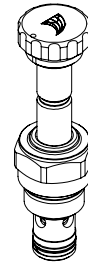
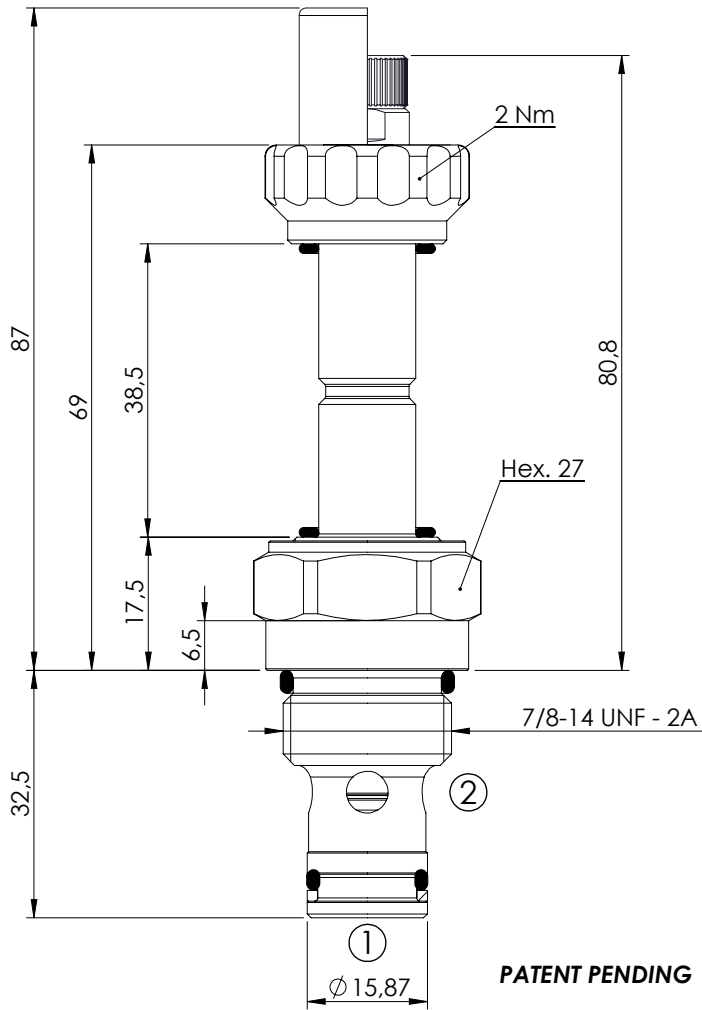

SPECIFICATIONS

Max. operating pressure:	350/500 bar
Rated flow:	70 l/min
Cavity:	SAE-10-2N
Weight:	0,18 kg
Min. voltage required:	90% of nominal
Coil type:	M7 type
Seal kit:	RA900082

NOTES

Installation torque: 55 - 62 Nm

OPTIONS

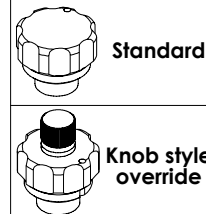

SEALING CAP

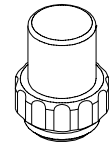

Ordering code:
AT000113

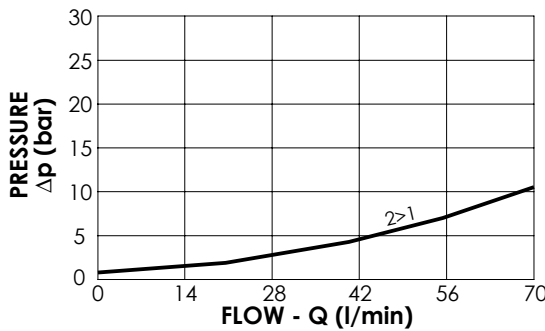

ORDERING CODES

Quick code	Description	Options	Max operating pressure (bar)
CE000245	CEBN-070-NCFN-01-S10-N350	Standard	350
CE000247	CEBN-070-NCFK-01-S10-N350	Knob style override	350
CE000545	CEBN-070-NCFN-01-S10-N500	Standard	500
CE000547	CEBN-070-NCFK-01-S10-N500	Knob style override	500

SOLENOID OPERATED CARTRIDGE

CEBN-100-NCFN

**PILOT OPERATED
POPPET TYPE**

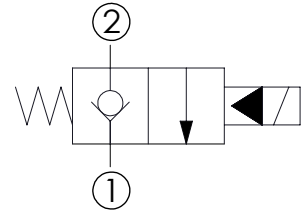
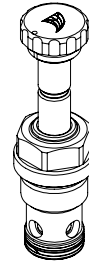
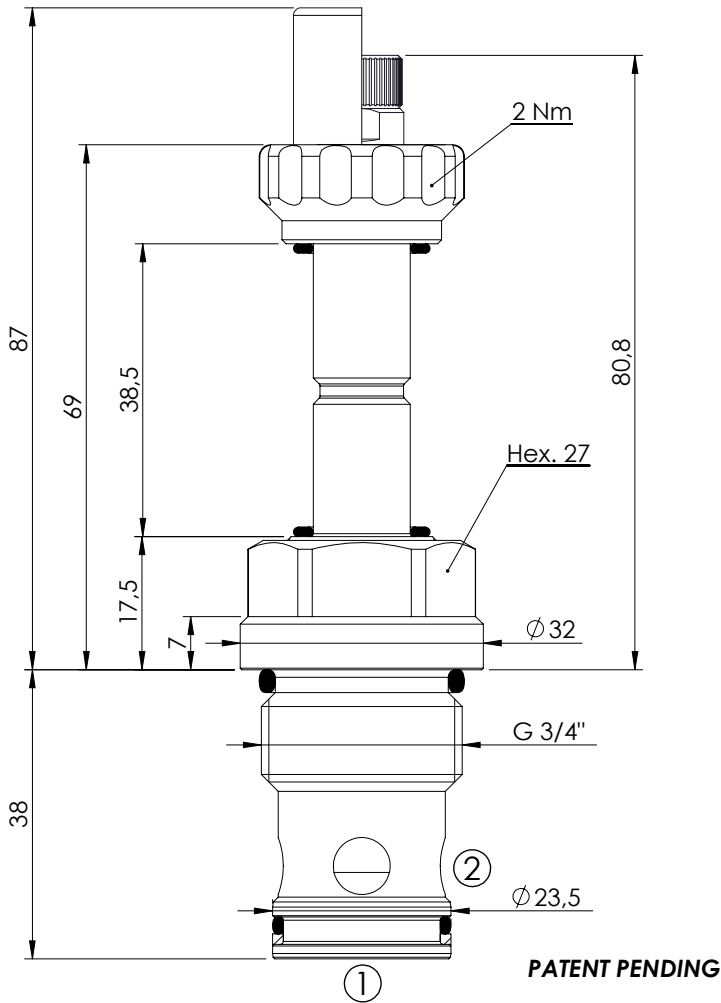

SPECIFICATIONS

Max. operating pressure:	350/500 bar
Rated flow:	100 l/min
Cavity:	VP000057
Weight:	0,25 kg
Min. voltage required:	90% of nominal
Coil type:	M7 type
Seal kit:	RC900057

NOTES

Installation torque: 110 - 130 Nm

OPTIONS

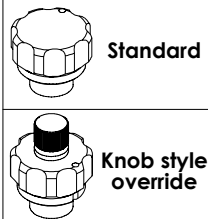

SEALING CAP

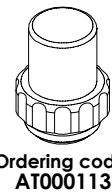

Ordering code:
AT000113

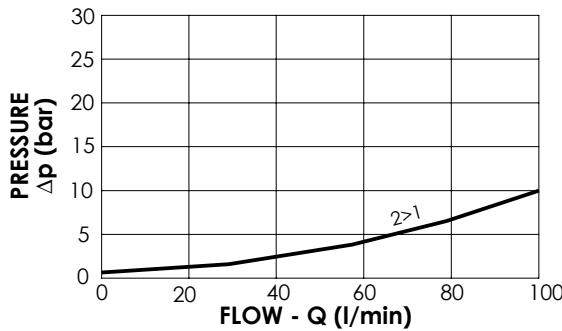

ORDERING CODES

Quick code	Description	Options	Max operating pressure (bar)
CE000280	CEBN-100-NCFN-01-057-N350	Standard	350
CE000282	CEBN-100-NCFK-01-057-N350	Knob style override	350
CE000580	CEBN-100-NCFN-01-057-N500	Standard	500
CE000582	CEBN-100-NCFK-01-057-N500	Knob style override	500

SOLENOID OPERATED CARTRIDGE

CEBN-180-NCFN

PILOT OPERATED
POPPET TYPE

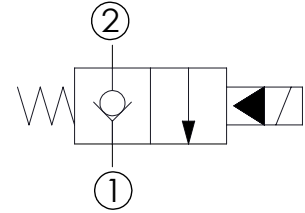
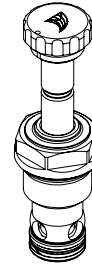
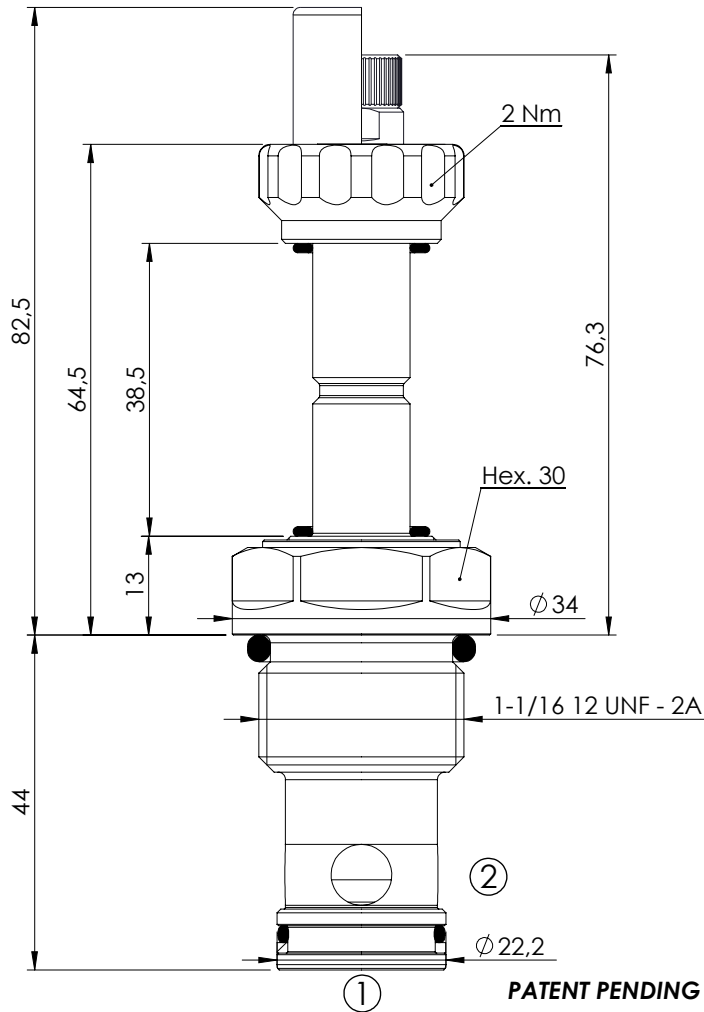

SPECIFICATIONS

Max. operating pressure:	350/500 bar
Rated flow:	180 l/min
Cavity:	SAE-12-2N
Weight:	0,25 kg
Min. voltage required:	90% of nominal
Coil type:	M7 type
Seal kit:	RA900083

NOTES

Installation torque: 135 - 150 Nm

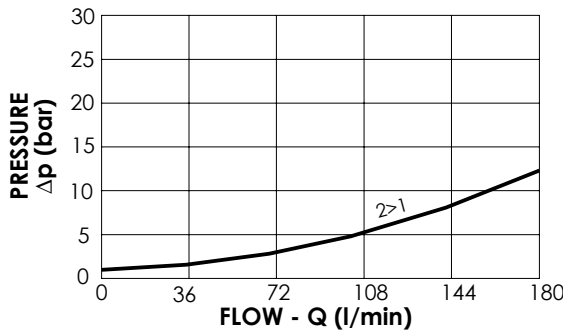

OPTIONS

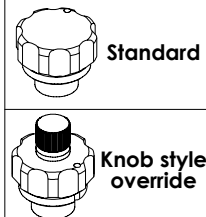

SEALING CAP

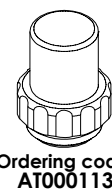

Ordering code: AT000113

ORDERING CODES

Quick code	Description	Options	Max operating pressure (bar)
CE000315	CEBN-180-NCFN-01-S12-N350	Standard	350
CE000317	CEBN-180-NCFK-01-S12-N350	Knob style override	350
CE000615	CEBN-180-NCFN-01-S12-N500	Standard	500
CE000617	CEBN-180-NCFK-01-S12-N500	Knob style override	500

SOLENOID OPERATED CARTRIDGE

CEBN-200-NCFN

**PILOT OPERATED
POPPET TYPE**

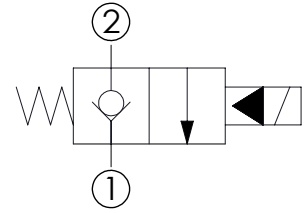
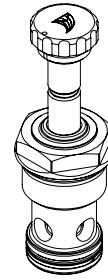
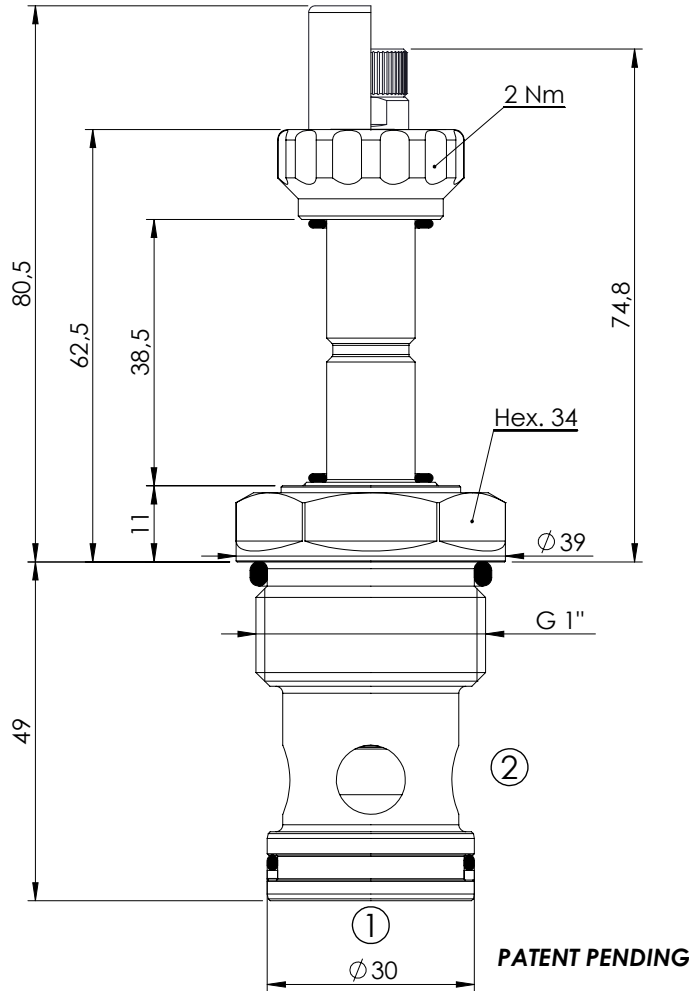

SPECIFICATIONS

Max. operating pressure:	350/500 bar
Rated flow:	200 l/min
Cavity:	VP000013
Weight:	0,35 kg
Min. voltage required:	90% of nominal
Coil type:	M7 type
Seal kit:	RC900013

NOTES

Installation torque: 135 - 150 Nm

OPTIONS



Standard

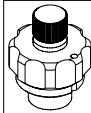

Knob style
override

SEALING CAP

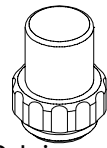

Ordering code:
AT000113

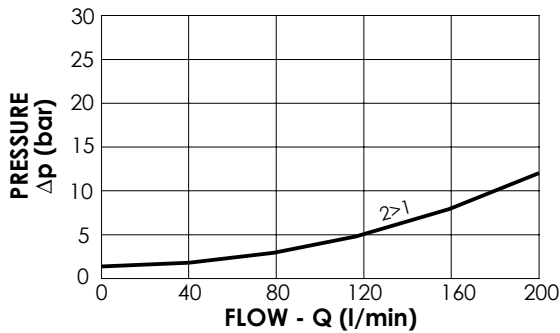

ORDERING CODES

Quick code	Description	Options	Max operating pressure (bar)
CE000350	CEBN-200-NCFN-01-013-N350	Standard	350
CE000352	CEBN-200-NCFK-01-013-N350	Knob style override	350
CE000650	CEBN-200-NCFN-01-013-N500	Standard	500
CE000652	CEBN-200-NCFK-01-013-N500	Knob style override	500

SOLENOID OPERATED CARTRIDGE

CEBN-300-NCFN

**PILOT OPERATED
POPPET TYPE**

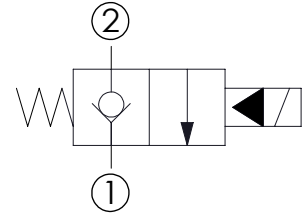
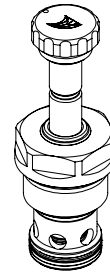
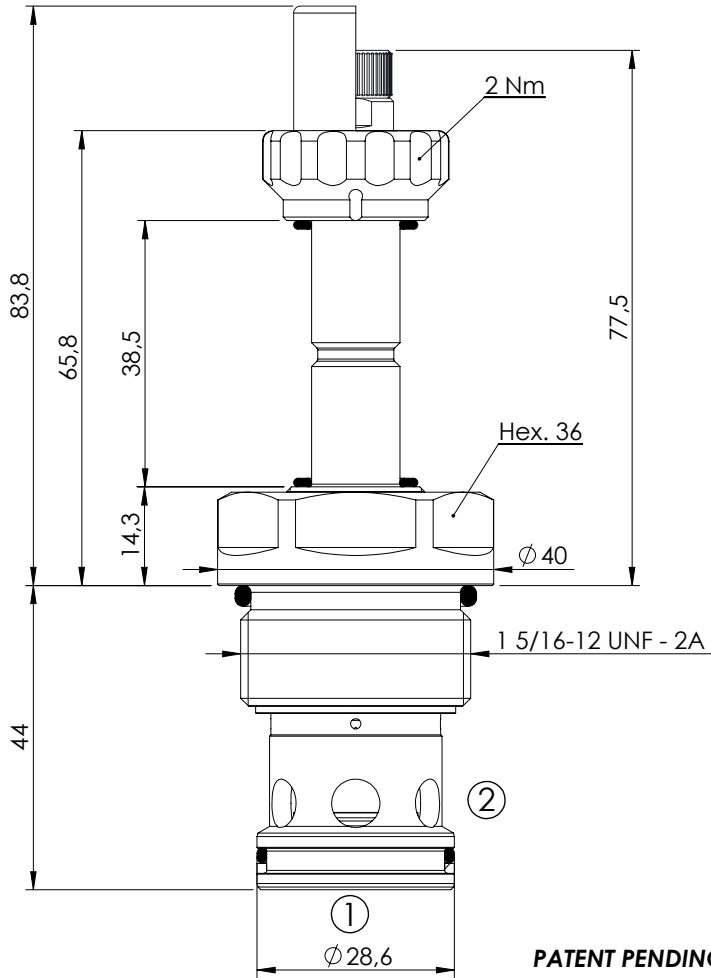

SPECIFICATIONS

Max. operating pressure:	350/500 bar
Rated flow:	300 l/min
Cavity:	SAE-16-2N
Weight:	0,36 kg
Min. voltage required:	90% of nominal
Coil type:	M7 type
Seal kit:	RA900084

NOTES

Installation torque: 118 - 132 Nm

OPTIONS

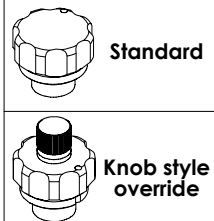

SEALING CAP

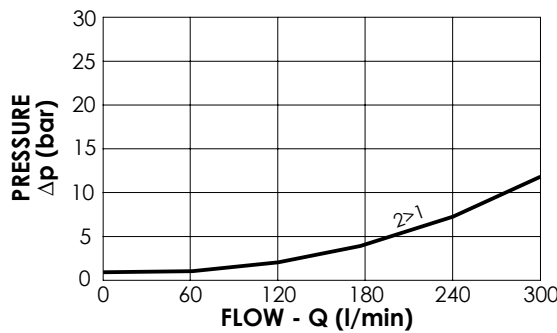
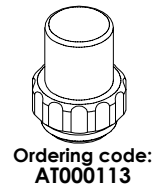

ORDERING CODES

Quick code	Description	Options	Max operating pressure (bar)
CE000385	CEBN-300-NCFN-01-S16-N350	Standard	350
CE000387	CEBN-300-NCFK-01-S16-N350	Knob style override	350
CE000685	CEBN-300-NCFN-01-S16-N500	Standard	500
CE000687	CEBN-300-NCFK-01-S16-N500	Knob style override	500

SOLENOID OPERATED CARTRIDGE

CEBN-030-NCFN

**PILOT OPERATED
POPPET TYPE**

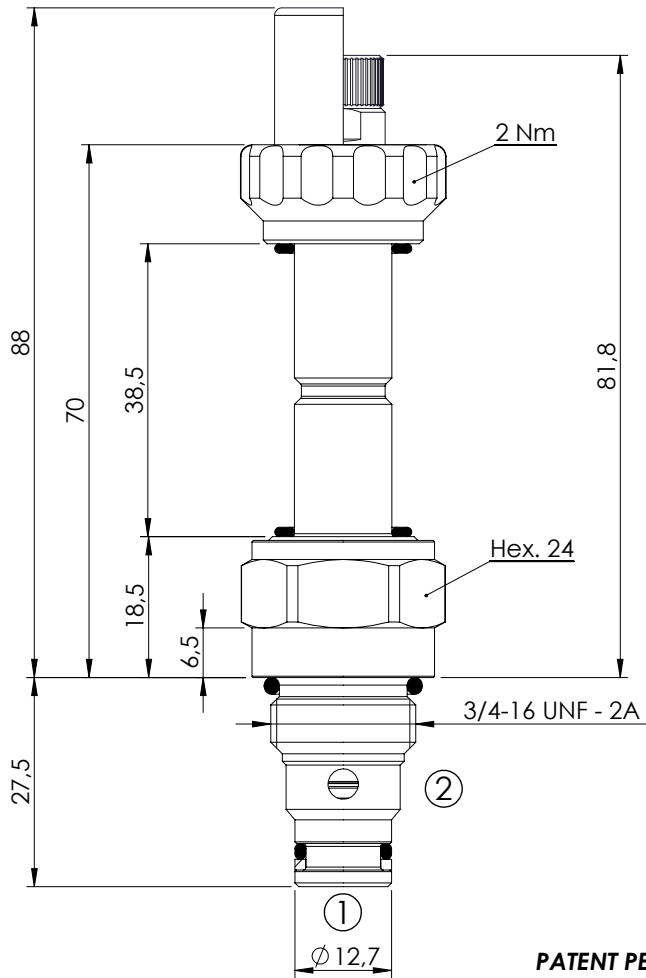

PATENT PENDING

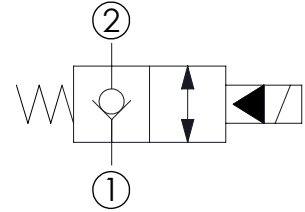
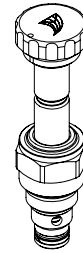

SPECIFICATIONS

Max. operating pressure:	350 bar
Rated flow:	30 l/min
Cavity:	SAE-08-2N
Weight:	0,15 kg
Min. voltage required:	90% of nominal
Coil type:	M7 type
Seal kit:	RA900081

NOTES

Installation torque: 45 - 50 Nm

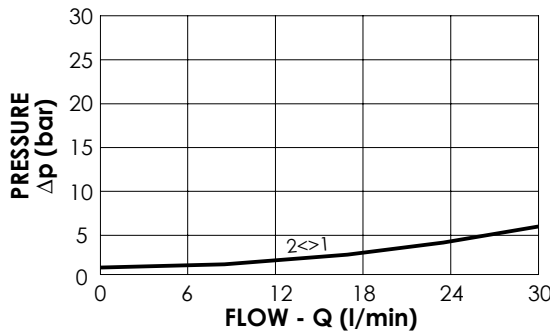

OPTIONS

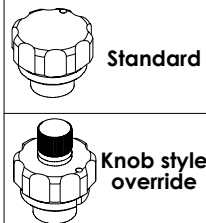

SEALING CAP

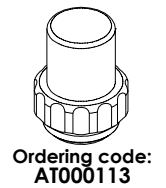

ORDERING CODES

Quick code	Description	Options	Max operating pressure (bar)
CE000457	CEBN-030-NCFN-05-S08-N350	Standard	350
CE000458	CEBN-030-NCFK-05-S08-N350	Knob style override	350

SOLENOID OPERATED CARTRIDGE

CEBN-040-NCFN

**PILOT OPERATED
POPPET TYPE**

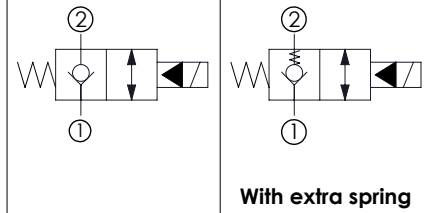
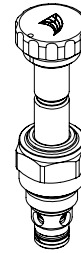
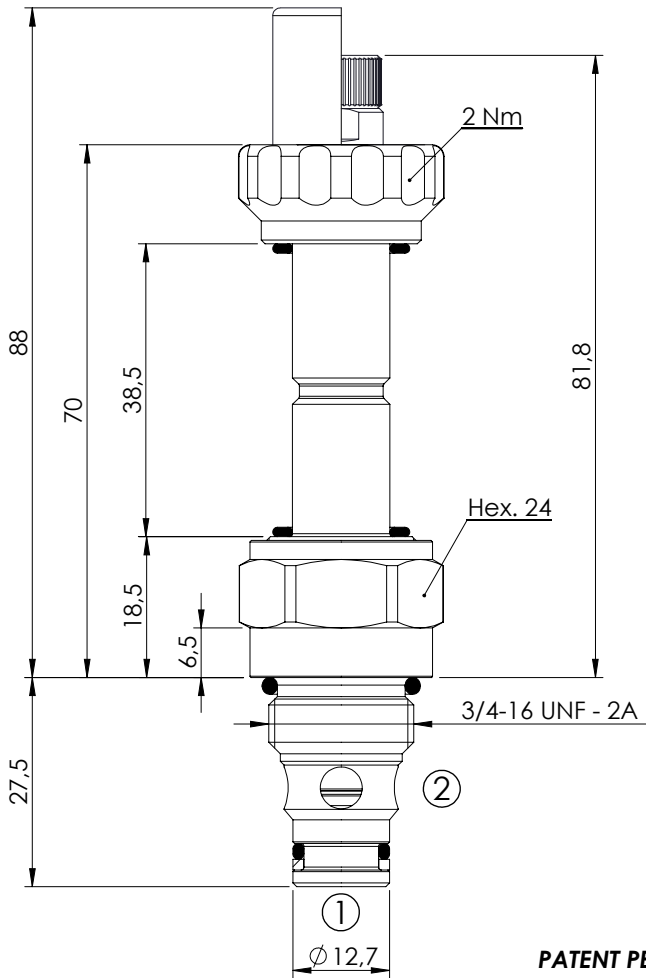

SPECIFICATIONS

Max. operating pressure:	350/500 bar
Rated flow:	40 l/min
Cavity:	SAE-08-2N
Weight:	0,14 kg
Min. voltage required:	90% of nominal
Coil type:	M7 type
Seal kit:	RA900081

NOTES

Installation torque: 45 - 50 Nm

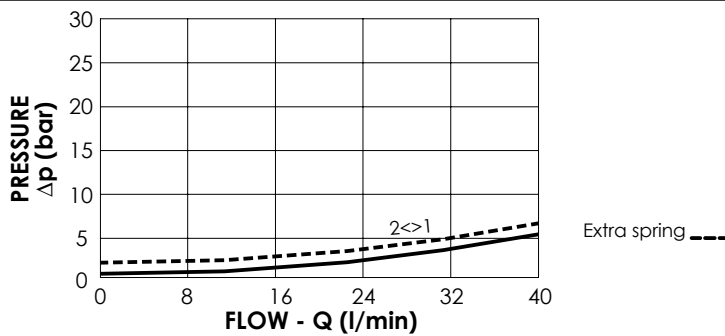

OPTIONS

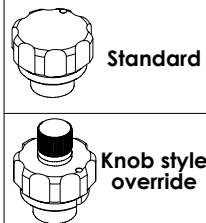

SEALING CAP

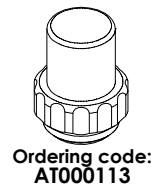

ORDERING CODES

Quick code	Description	Options	Max operating pressure (bar)	Extra Spring
CE000218	CEBN-040-NCFN-05-S08-N350	Standard	350	No
CE000220	CEBN-040-NCFK-05-S08-N350	Knob style override	350	No
CE000219	CEBN-040-XCFN-05-S08-N350	Standard	350	Yes
CE000221	CEBN-040-XCFK-05-S08-N350	Knob style override	350	Yes
CE000518	CEBN-040-NCFN-05-S08-N500	Standard	500	No
CE000520	CEBN-040-NCFK-05-S08-N500	Knob style override	500	No

SOLENOID OPERATED CARTRIDGE

CEBN-070-NCFN

**PILOT OPERATED
POPPET TYPE**

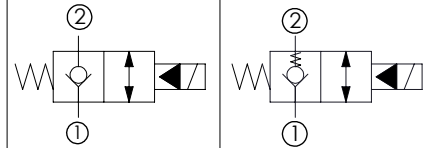
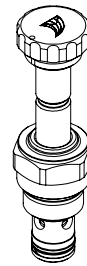
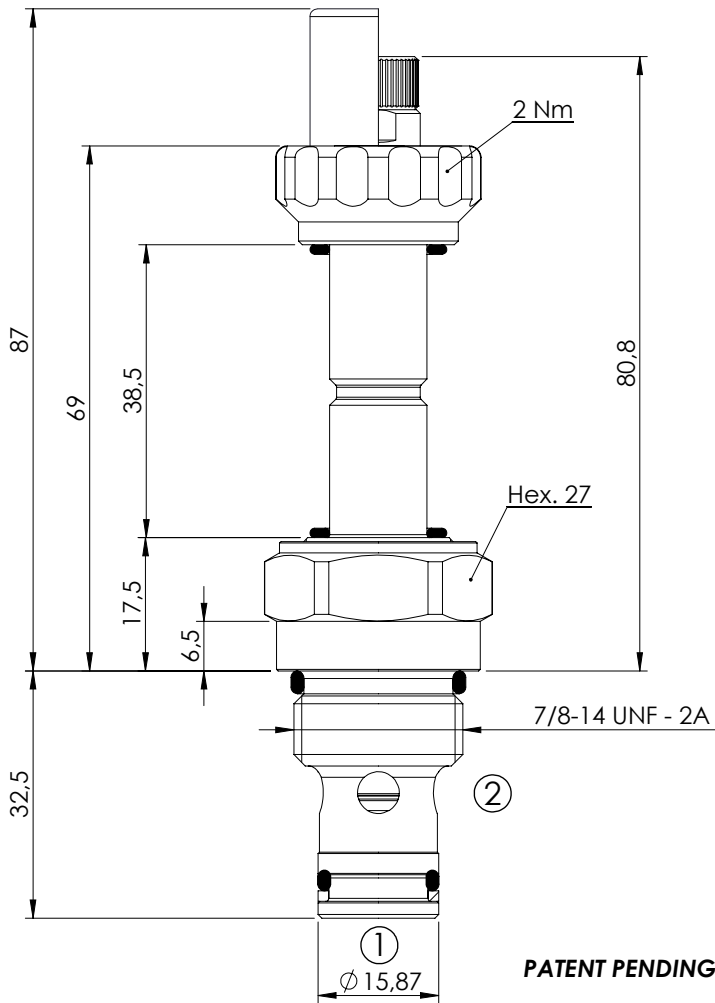

With extra spring

SPECIFICATIONS

Max. operating pressure:	350/500 bar
Rated flow:	70 l/min
Cavity:	SAE-10-2N
Weight:	0,18 kg
Min. voltage required:	90% of nominal
Coil type:	M7 type
Seal kit:	RA900082

NOTES

Installation torque: 55 - 62 Nm

OPTIONS

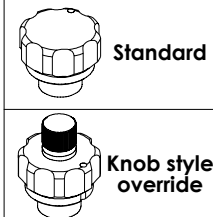

SEALING CAP

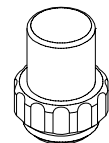

Ordering code:
AT000113

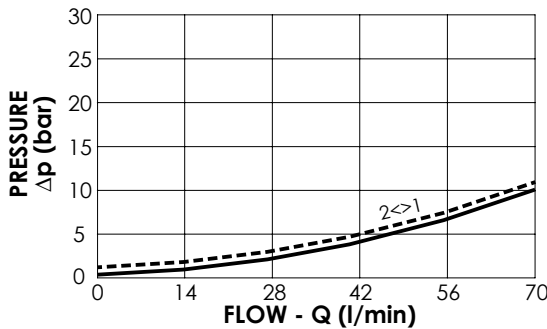

Extra spring - - - - -

ORDERING CODES

Quick code	Description	Options	Max operating pressure (bar)	Extra Spring
CE000253	CEBN-070-NCFN-05-S10-N350	Standard	350	No
CE000255	CEBN-070-NCFK-05-S10-N350	Knob style override	350	No
CE000254	CEBN-070-XCFN-05-S10-N350	Standard	350	Yes
CE000256	CEBN-070-XCFK-05-S10-N350	Knob style override	350	Yes
CE000553	CEBN-070-NCFN-05-S10-N500	Standard	500	No
CE000555	CEBN-070-NCFK-05-S10-N500	Knob style override	500	No

SOLENOID OPERATED CARTRIDGE

CEBN-100-NCFN

**PILOT OPERATED
POPPET TYPE**

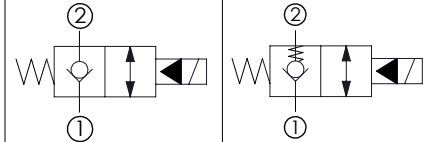
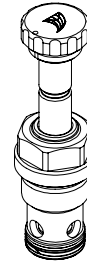
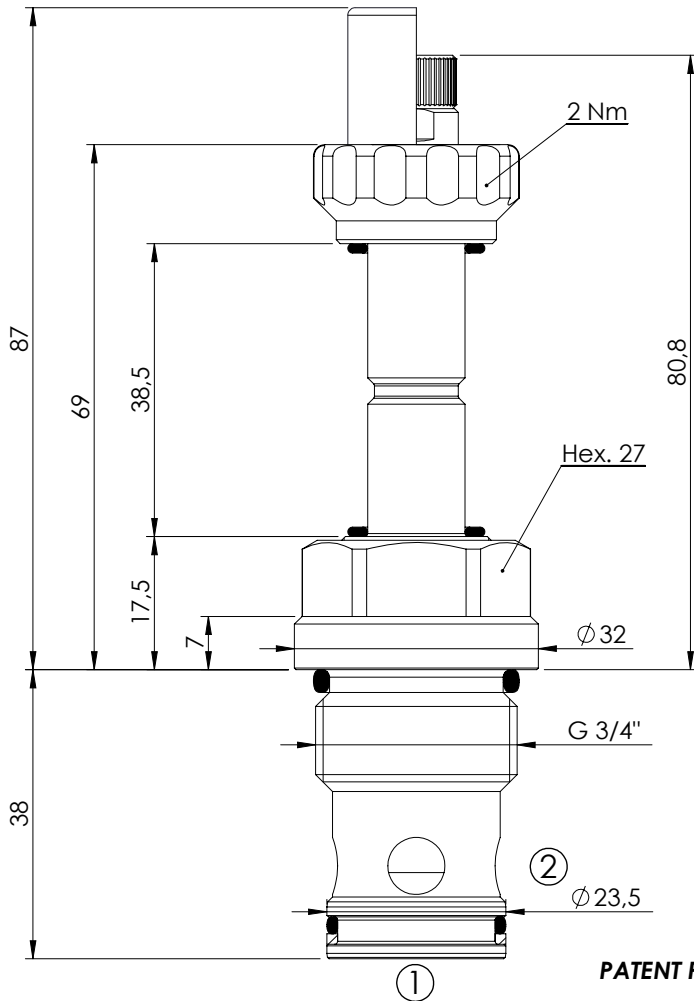

SPECIFICATIONS

Max. operating pressure:	350/500 bar
Rated flow:	100 l/min
Cavity:	VP000057
Weight:	0,25 kg
Min. voltage required:	90% of nominal
Coil type:	M7 type
Seal kit:	RC900057

NOTES

Installation torque: 110 - 130 Nm

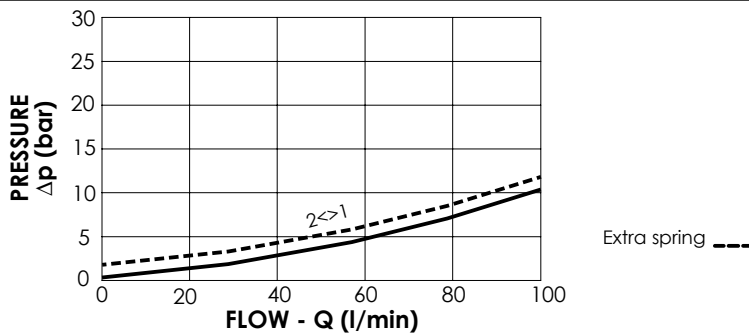

OPTIONS

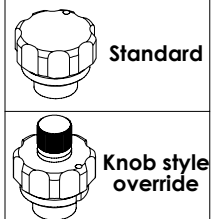

SEALING CAP

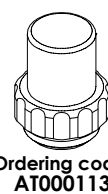

ORDERING CODES

Quick code	Description	Options	Max operating pressure (bar)	Extra Spring
CE000288	CEBN-100-NCFN-05-057-N350	Standard	350	No
CE000290	CEBN-100-NCFK-05-057-N350	Knob style override	350	No
CE000289	CEBN-100-XCFN-05-057-N350	Standard	350	Yes
CE000291	CEBN-100-XCFK-05-057-N350	Knob style override	350	Yes
CE000588	CEBN-100-NCFN-05-057-N500	Standard	500	No
CE000590	CEBN-100-NCFK-05-057-N500	Knob style override	500	No

SOLENOID OPERATED CARTRIDGE

CEBN-180-NCFN

**PILOT OPERATED
POPPET TYPE**

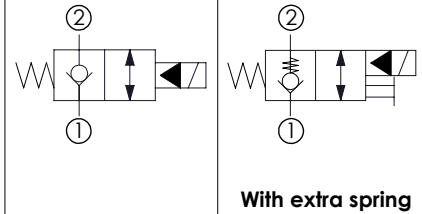
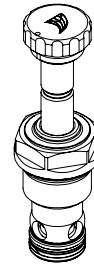
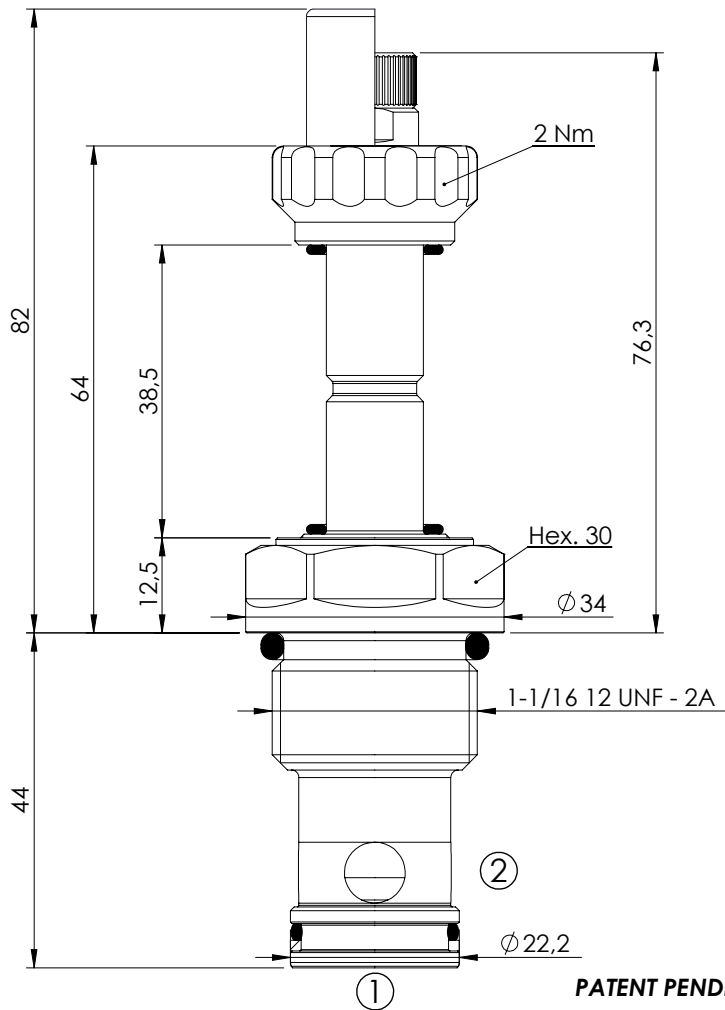

SPECIFICATIONS

Max. operating pressure:	350/500 bar
Rated flow:	180 l/min
Cavity:	SAE-12-2N
Weight:	0,25 kg
Min. voltage required:	90% of nominal
Coil type:	M7 type
Seal kit:	RA900083

NOTES

Installation torque: 135 - 150 Nm

OPTIONS

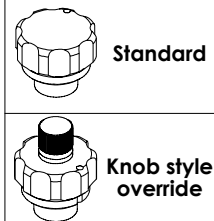

SEALING CAP

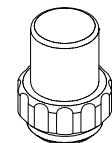

Ordering code:
AT000113

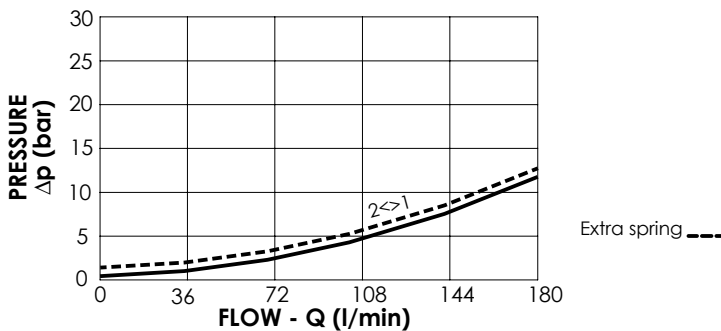

ORDERING CODES

Quick code	Description	Options	Max operating pressure (bar)	Extra Spring
CE000323	CEBN-180-NCFN-05-S12-N350	Standard	350	No
CE000325	CEBN-180-NCFK-05-S12-N350	Knob style override	350	No
CE000324	CEBN-180-XCFN-05-S12-N350	Standard	350	Yes
CE000326	CEBN-180-XCFK-05-S12-N350	Knob style override	350	Yes
CE000623	CEBN-180-NCFN-05-S12-N500	Standard	500	No
CE000625	CEBN-180-NCFK-05-S12-N500	Knob style override	500	No

SOLENOID OPERATED CARTRIDGE

CEBN-200-NCFN

**PILOT OPERATED
POPPET TYPE**

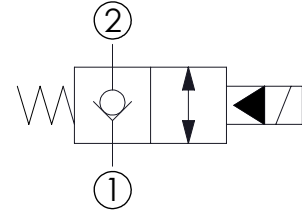
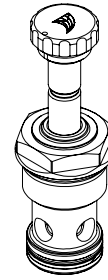
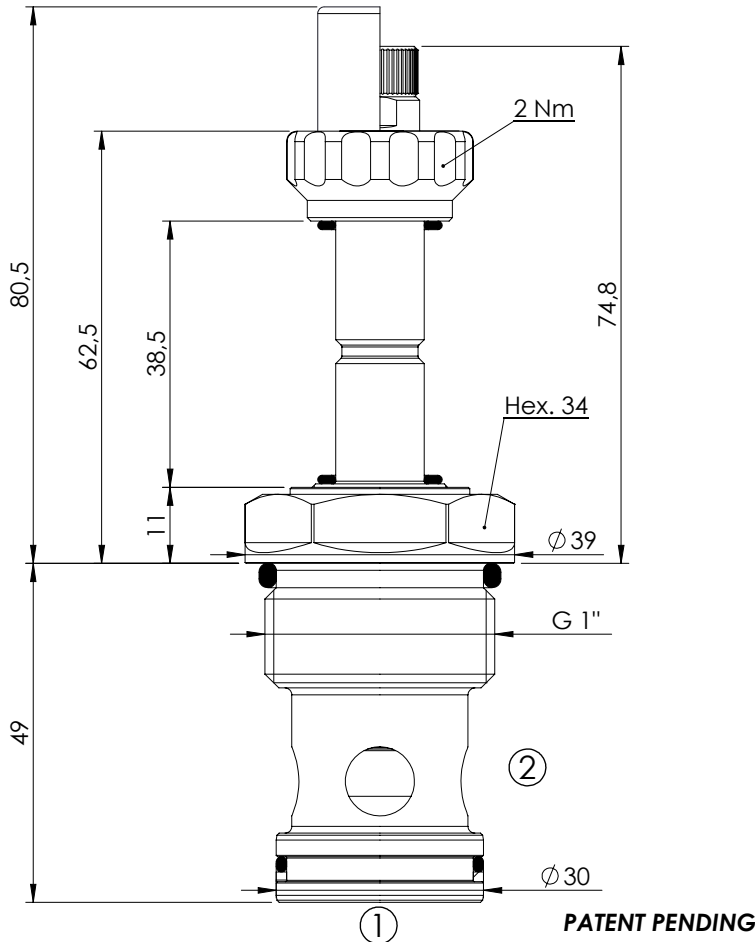

SPECIFICATIONS

Max. operating pressure:	350/500 bar
Rated flow:	200 l/min
Cavity:	VP000013
Weight:	0,35 kg
Min. voltage required:	90% of nominal
Coil type:	M7 type
Seal kit:	RC900013

NOTES

Installation torque: 135 - 150 Nm

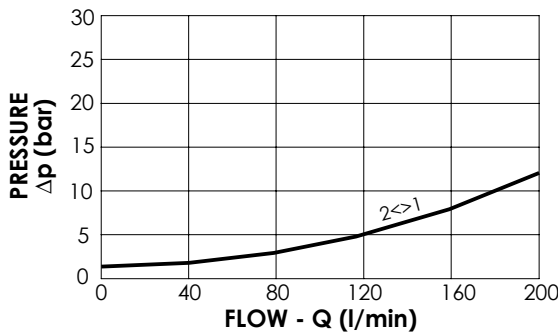

OPTIONS

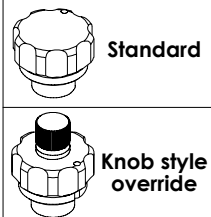

SEALING CAP

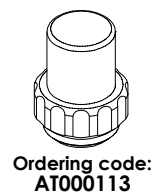

ORDERING CODES

Quick code	Description	Options	Max operating pressure (bar)
CE000358	CEBN-200-NCFN-05-013-N350	Standard	350
CE000360	CEBN-200-NCFK-05-013-N350	Knob style override	350
CE000658	CEBN-200-NCFN-05-013-N500	Standard	500
CE000660	CEBN-200-NCFK-05-013-N500	Knob style override	500

SOLENOID OPERATED CARTRIDGE

CEBN-300-NCFN

**PILOT OPERATED
POPPET TYPE**

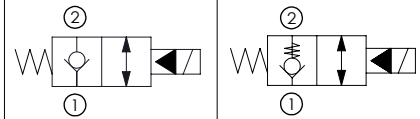
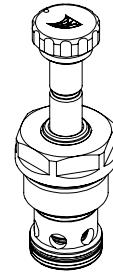
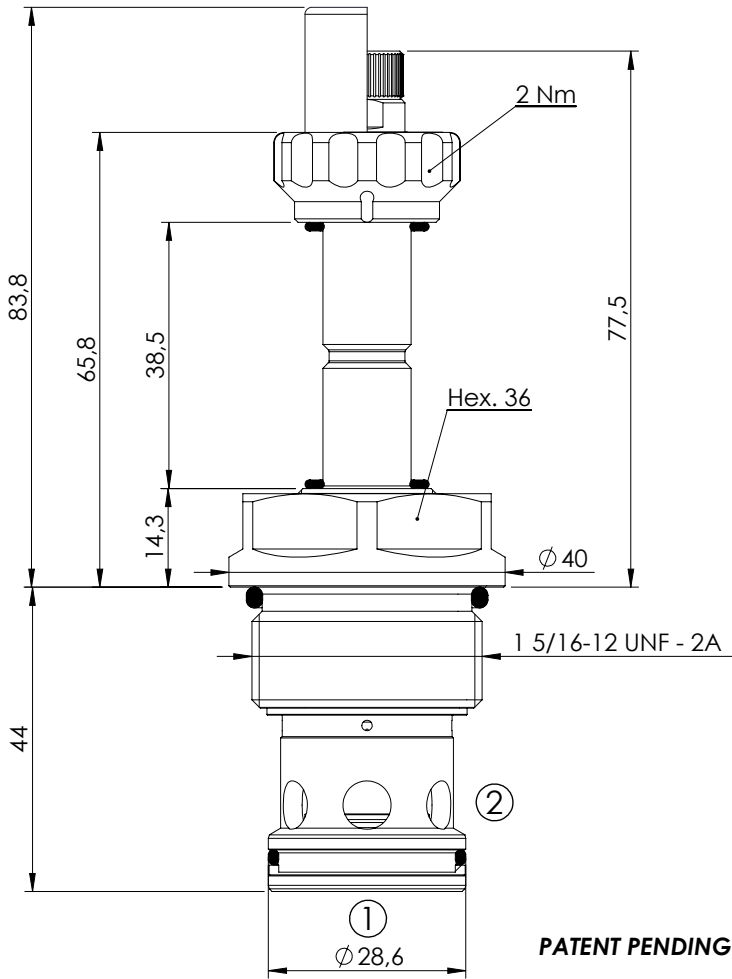

SPECIFICATIONS

Max. operating pressure:	350/500 bar
Rated flow:	300 l/min
Cavity:	SAE-16-2N
Weight:	0,36 kg
Min. voltage required:	90% of nominal
Coil type:	M7 type
Seal kit:	RA900084

NOTES

Installation torque: 118 - 132 Nm

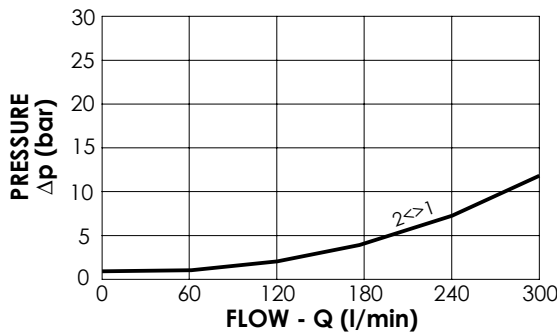

OPTIONS

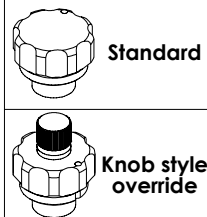

SEALING CAP

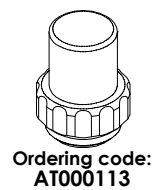

ORDERING CODES

Quick code	Description	Options	Max operating pressure (bar)	Extra Spring
CE000393	CEBN-300-NCFN-05-S16-N350	Standard	350	No
CE000395	CEBN-300-NCFK-05-S16-N350	Knob style override	350	No
CE000394	CEBN-300-XCFN-05-S16-N350	Standard	350	Yes
CE000396	CEBN-300-XCFK-05-S16-N350	Knob style override	350	Yes
CE000693	CEBN-300-NCFN-05-S16-N500	Standard	500	No
CE000695	CEBN-300-NCFK-05-S16-N500	Knob style override	500	No

SOLENOID OPERATED CARTRIDGE

CEBN-040-NCFN

**PILOT OPERATED
POPPET TYPE**

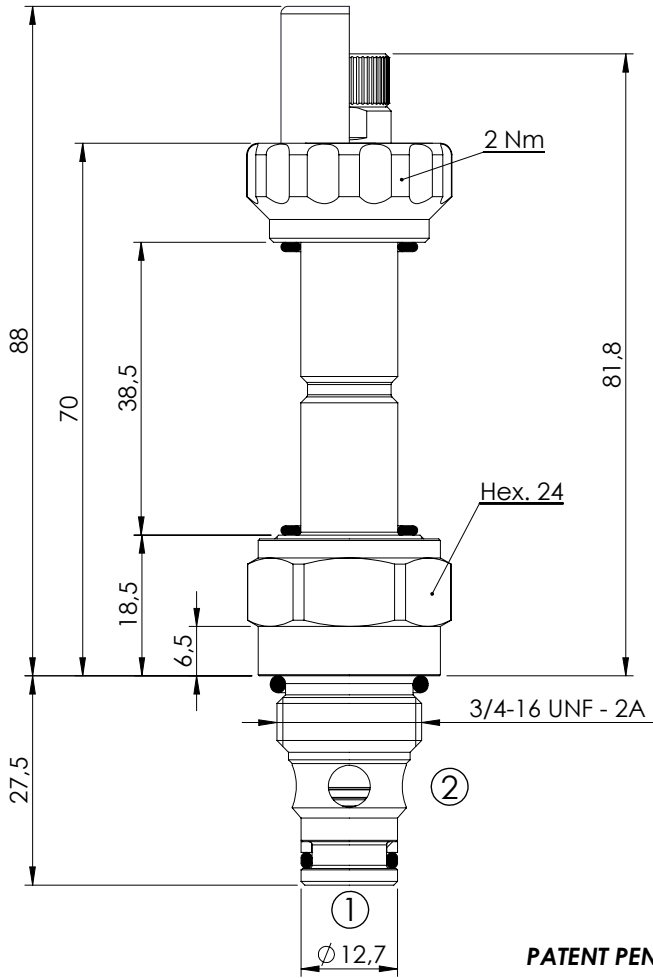

PATENT PENDING

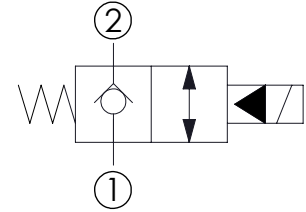
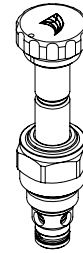

SPECIFICATIONS

Max. operating pressure:	350/500 bar
Rated flow:	40 l/min
Cavity:	SAE-08-2N
Weight:	0,14 kg
Min. voltage required:	90% of nominal
Coil type:	M7 type
Seal kit:	RA900081

NOTES

Installation torque: 45 - 50 Nm

OPTIONS



Standard

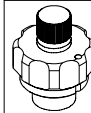

Knob style
override

SEALING CAP

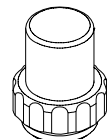

Ordering code:
AT000113

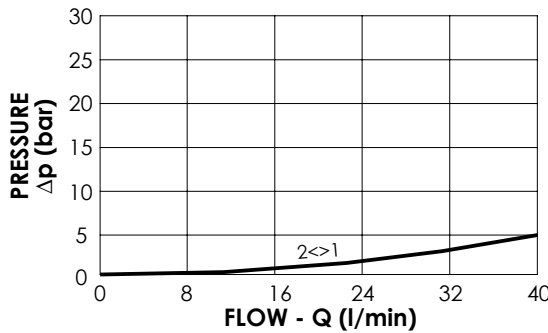

ORDERING CODES

Quick code	Description	Options	Max operating pressure (bar)
CE000214	CEBN-040-NCFN-03-S08-N350	Standard	350
CE000216	CEBN-040-NCFK-03-S08-N350	Knob style override	350
CE000514	CEBN-040-NCFN-03-S08-N500	Standard	500
CE000516	CEBN-040-NCFK-03-S08-N500	Knob style override	500

SOLENOID OPERATED CARTRIDGE

CEBN-070-NCFN

**PILOT OPERATED
POPPET TYPE**

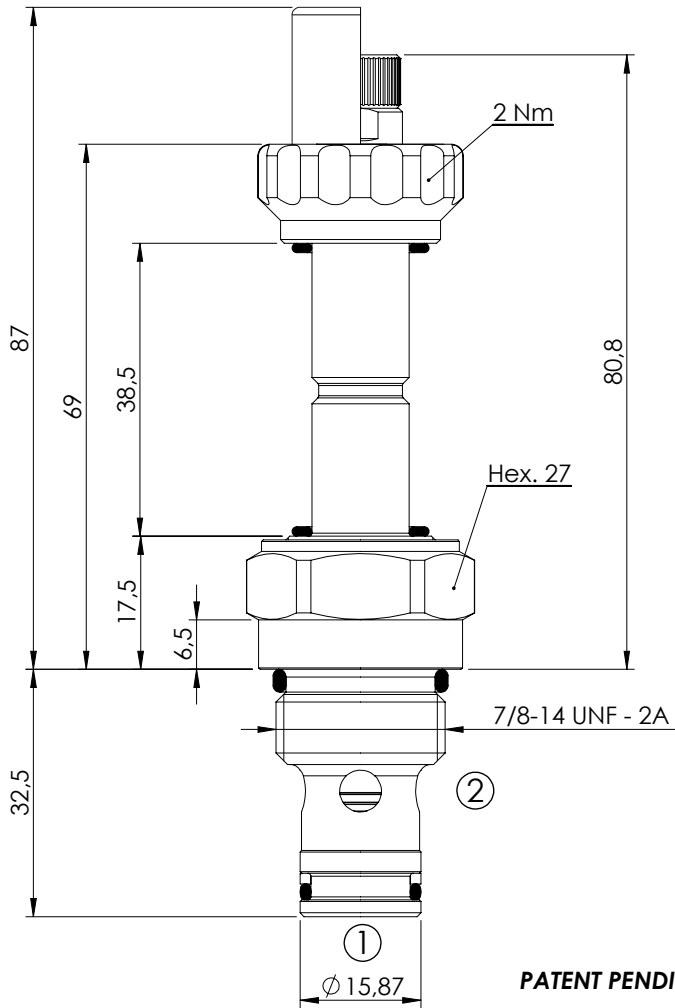

PATENT PENDING

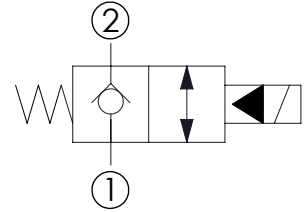
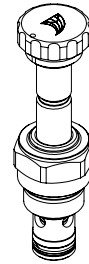

SPECIFICATIONS

Max. operating pressure:	350/500 bar
Rated flow:	70 l/min
Cavity:	SAE-10-2N
Weight:	0,18 kg
Min. voltage required:	90% of nominal
Coil type:	M7 type
Seal kit:	RA900082

NOTES

Installation torque: 55 - 62 Nm

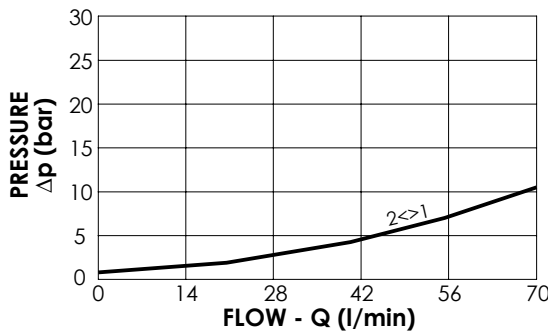

OPTIONS

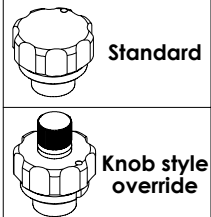

SEALING CAP

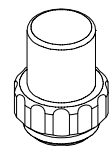

Ordering code:
AT000113

ORDERING CODES

Quick code	Description	Options	Max operating pressure (bar)
CE000249	CEBN-070-NCFN-03-S10-N350	Standard	350
CE000251	CEBN-070-NCFK-03-S10-N350	Knob style override	350
CE000549	CEBN-070-NCFN-03-S10-N500	Standard	500
CE000551	CEBN-070-NCFK-03-S10-N500	Knob style override	500

SOLENOID OPERATED CARTRIDGE

CEBN-100-NCFN

**PILOT OPERATED
POPPET TYPE**

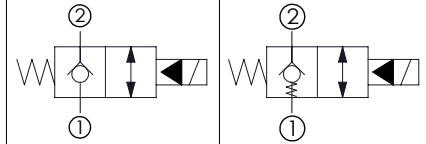
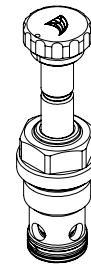
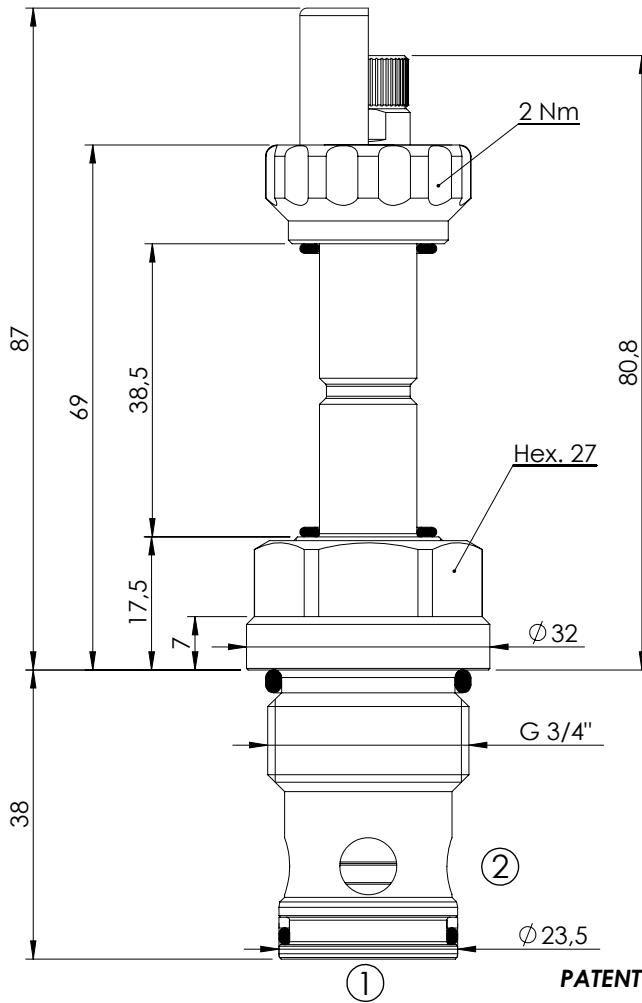

SPECIFICATIONS

Max. operating pressure:	350/500 bar
Rated flow:	100 l/min
Cavity:	VP000057
Weight:	0,25 kg
Min. voltage required:	90% of nominal
Coil type:	M7 type
Seal kit:	RC900057

NOTES

Installation torque: 110 - 130 Nm

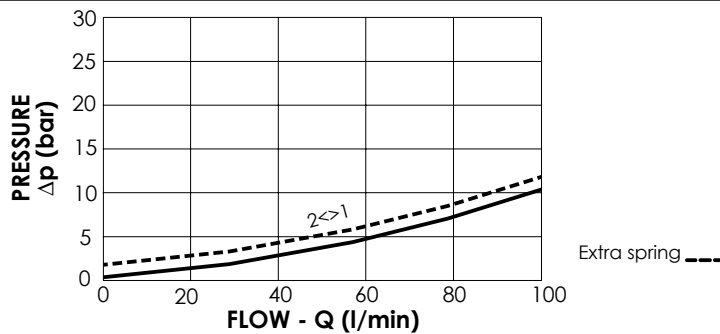

OPTIONS

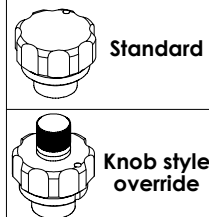

SEALING CAP

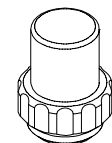

Ordering code:
AT000113

ORDERING CODES

Quick code	Description	Options	Max operating pressure (bar)	Extra Spring
CE000284	CEBN-100-NCFN-03-057-N350	Standard	350	No
CE000286	CEBN-100-NCFK-03-057-N350	Knob style override	350	No
CE000584	CEBN-100-NCFN-03-057-N500	Standard	500	No
CE000586	CEBN-100-NCFK-03-057-N500	Knob style override	500	No
CE000585	CEBN-100-XCFN-03-057-N500	Standard	500	Yes
CE000587	CEBN-100-XCFK-03-057-N500	Knob style override	500	Yes

SOLENOID OPERATED CARTRIDGE

CEBN-200-NCFN

**PILOT OPERATED
POPPET TYPE**

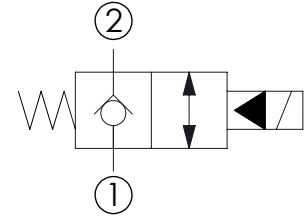
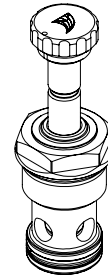
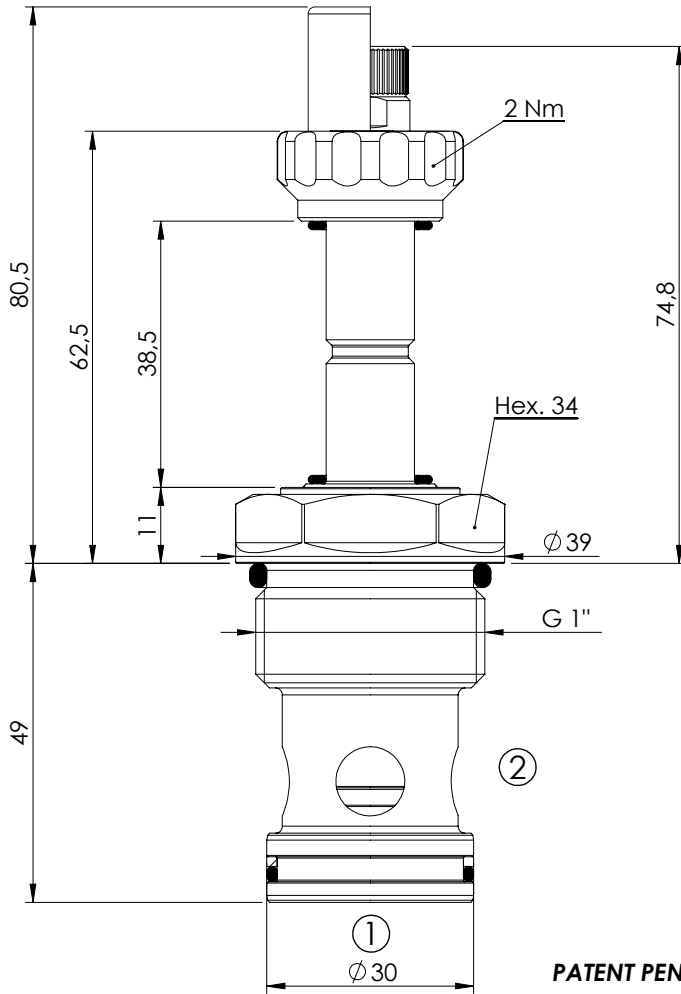

SPECIFICATIONS

Max. operating pressure:	350 bar
Rated flow:	200 l/min
Cavity:	VP000013
Weight:	0,35 kg
Min. voltage required:	90% of nominal
Coil type:	M7 type
Seal kit:	RC900013

NOTES

Installation torque: 135 - 150 Nm

OPTIONS

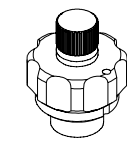

Knob style
override

SEALING CAP

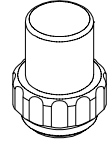

Ordering code:
AT000113

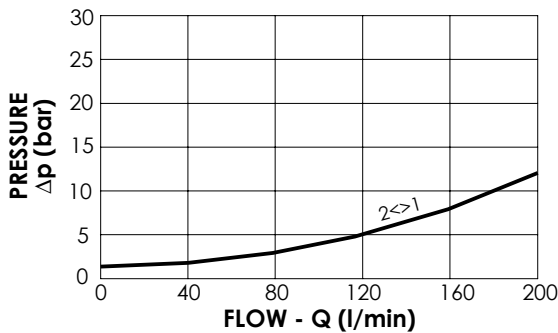

ORDERING CODES

Quick code	Description	Options	Max operating pressure (bar)
CE000354	CEBN-200-NCFN-03-013-N350	Standard	350
CE000356	CEBN-200-NCFK-03-013-N350	Knob style override	350
CE000654	CEBN-200-NCFN-03-013-N500	Standard	500
CE000656	CEBN-200-NCFK-03-013-N500	Knob style override	500

SOLENOID OPERATED CARTRIDGE

CEBN-300-NCFN

**PILOT OPERATED
POPPET TYPE**

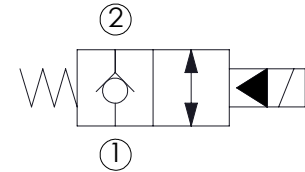
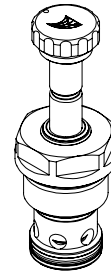
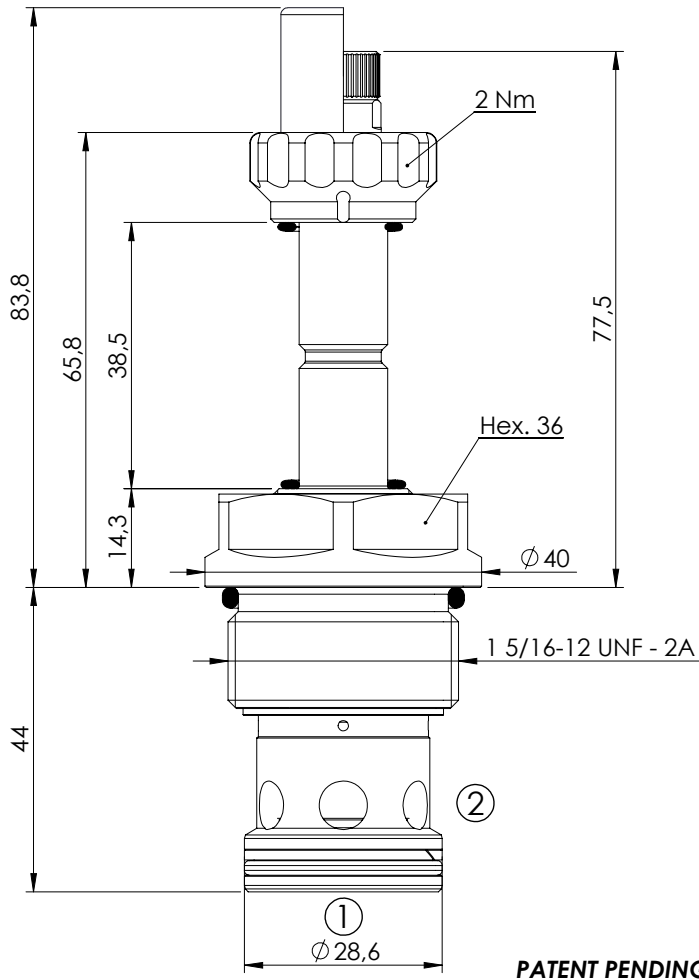

SPECIFICATIONS

Max. operating pressure:	350/500 bar
Rated flow:	300 l/min
Cavity:	SAE-16-2N
Weight:	0,37 kg
Min. voltage required:	90% of nominal
Coil type:	M7 type
Seal kit:	RA700084

NOTES

Installation torque: 118 - 132 Nm

OPTIONS

- Standard
- Knob style override

SEALING CAP

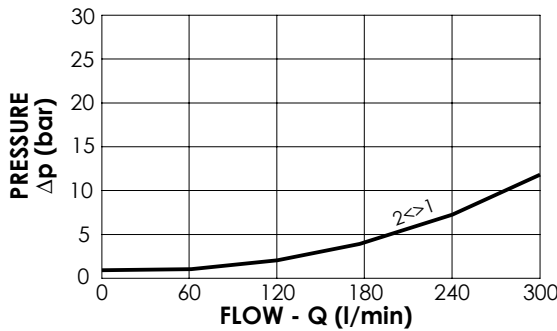
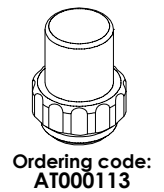

ORDERING CODES

Quick code	Description	Options	Max operating pressure (bar)
CE000389	CEBN-300-NCFN-03-S16-N350	Standard	350
CE000391	CEBN-300-NCFK-03-S16-N350	Knob style override	350
CE000689	CEBN-300-NCFN-03-S16-N500	Standard	500
CE000691	CEBN-300-NCFK-03-S16-N500	Knob style override	500

SOLENOID OPERATED CARTRIDGE

CEBN-030-NAFN

**PILOT OPERATED
POPPET TYPE**

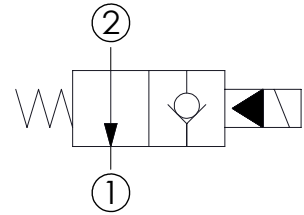
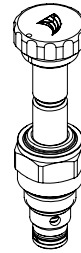
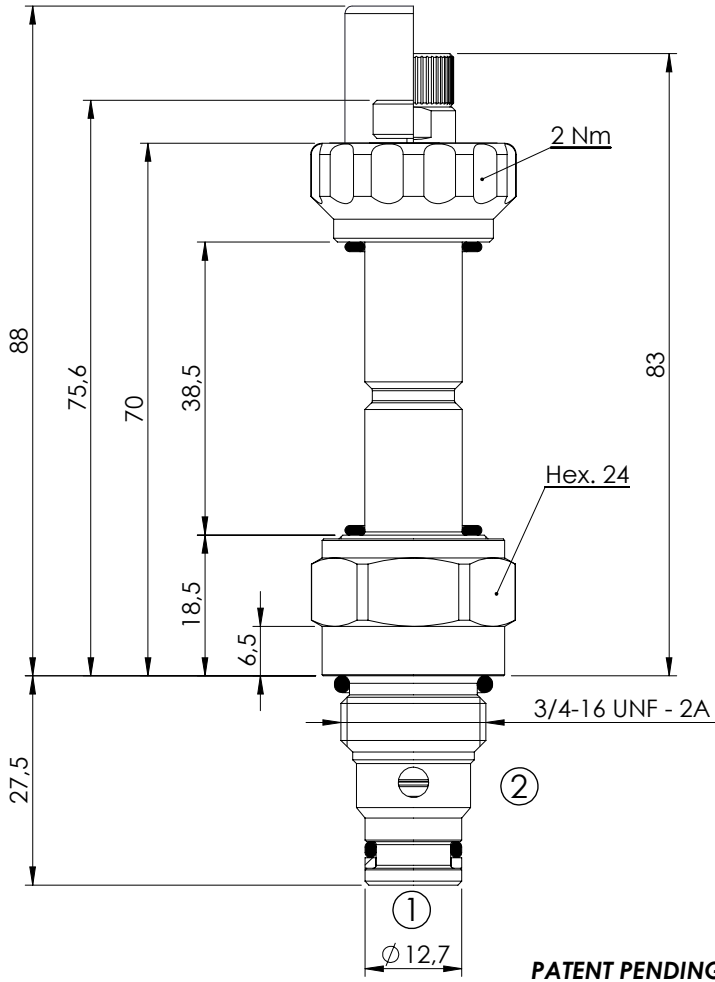

SPECIFICATIONS

Max. operating pressure:	350 bar
Rated flow:	30 l/min
Cavity:	SAE-08-2N
Weight:	0,15 kg
Min. voltage required:	90% of nominal
Coil type:	M7 type
Seal kit:	RA900081

NOTES

Installation torque: 45 - 50 Nm

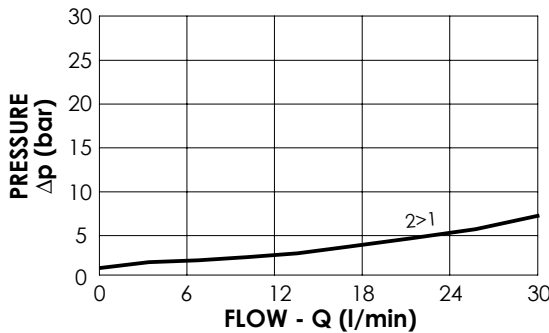

OPTIONS

- Standard
- Push style override
- Knob style override

SEALING CAP

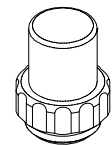

Ordering code:
AT000113

ORDERING CODES

Quick code	Description	Options	Max operating pressure (bar)
CE000461	CEBN-030-NAFN-02-S08-N350	Standard	350
CE000462	CEBN-030-NAFP-02-S08-N350	Push style override	350
CE000463	CEBN-030-NAFK-02-S08-N350	Knob style override	350

SOLENOID OPERATED CARTRIDGE

CEBN-040-NAFN

**PILOT OPERATED
POPPET TYPE**

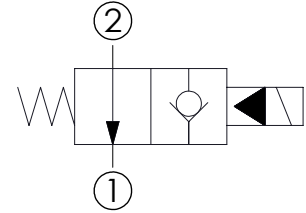
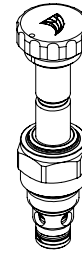
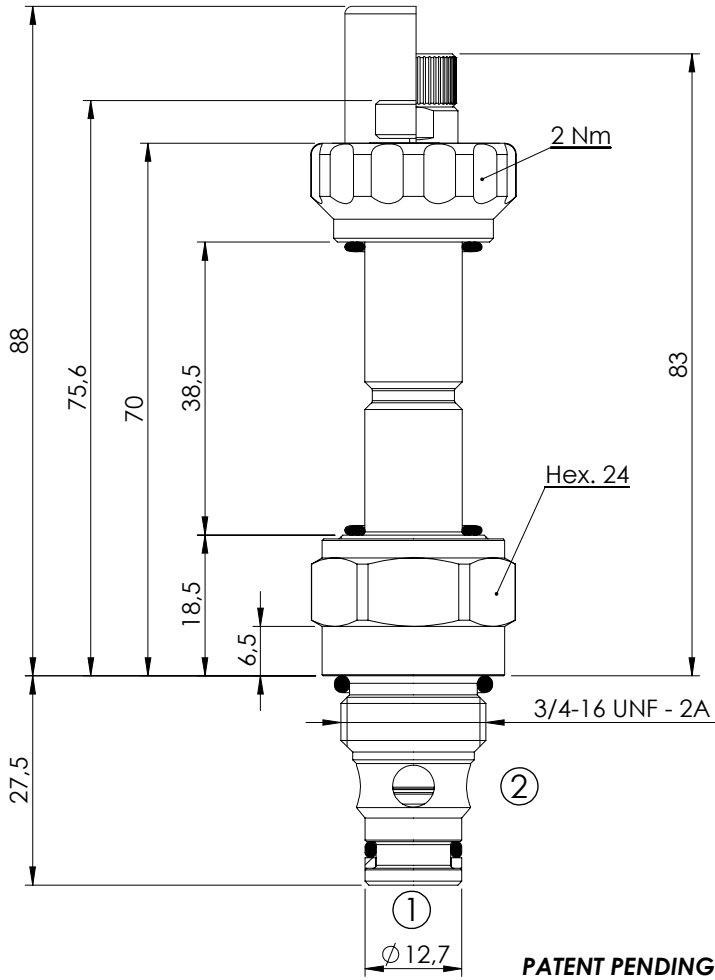

SPECIFICATIONS

Max. operating pressure:	350/500 bar
Rated flow:	40 l/min
Cavity:	SAE-08-2N
Weight:	0,14 kg
Min. voltage required:	90% of nominal
Coil type:	M7 type
Seal kit:	RA900081

NOTES

Installation torque: 45 - 50 Nm

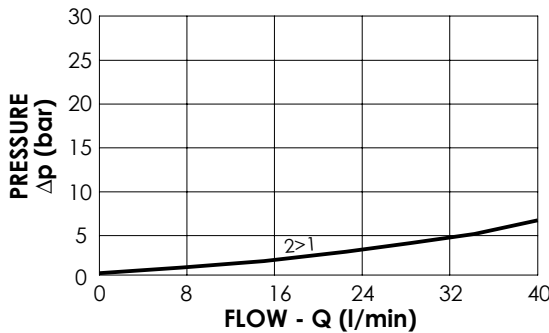

OPTIONS

- Standard
- Push style override
- Knob style override

SEALING CAP

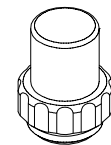

Ordering code:
AT000113

ORDERING CODES

Quick code	Description	Options	Max operating pressure (bar)
CE000230	CEBN-040-NAFN-02-S08-N350	Standard	350
CE000231	CEBN-040-NAFP-02-S08-N350	Push style override	350
CE000232	CEBN-040-NAFK-02-S08-N350	Knob style override	350
CE000530	CEBN-040-NAFN-02-S08-N500	Standard	500
CE000531	CEBN-040-NAFP-02-S08-N500	Push style override	500
CE000532	CEBN-040-NAFK-02-S08-N500	Knob style override	500

SOLENOID OPERATED CARTRIDGE

CEBN-070-NAFN

**PILOT OPERATED
POPPET TYPE**

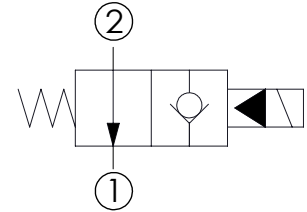
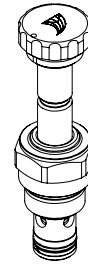
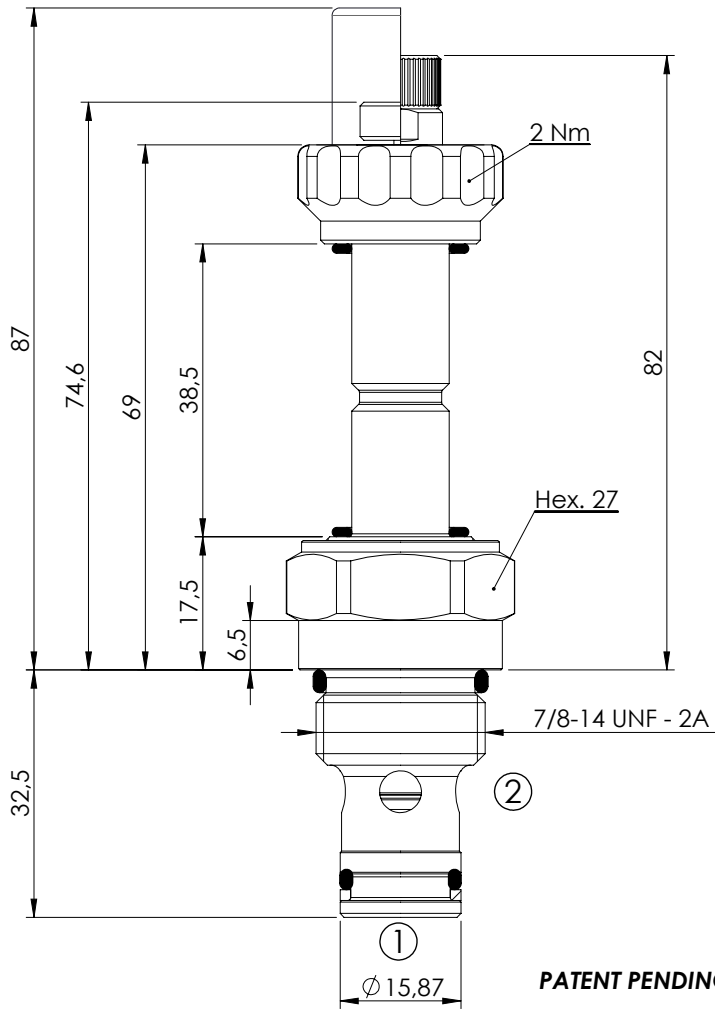

SPECIFICATIONS

Max. operating pressure:	350/500 bar
Rated flow:	70 l/min
Cavity:	SAE-10-2N
Weight:	0,18 kg
Min. voltage required:	90% of nominal
Coil type:	M7 type
Seal kit:	RA900082

NOTES

Installation torque: 55 - 62 Nm

OPTIONS

- Standard
- Push style override
- Knob style override

SEALING CAP

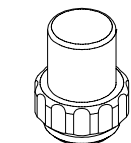

Ordering code:
AT000113

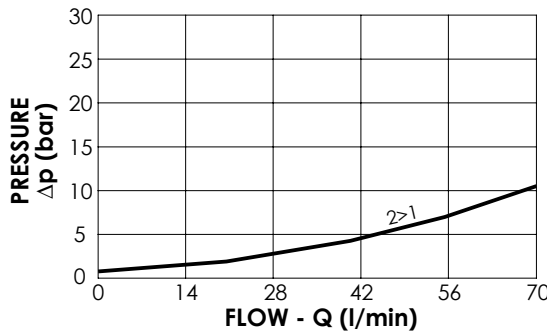

ORDERING CODES

Quick code	Description	Options	Max operating pressure (bar)
CE000265	CEBN-070-NAFN-02-S10-N350	Standard	350
CE000266	CEBN-070-NAFP-02-S10-N350	Push style override	350
CE000267	CEBN-070-NAFK-02-S10-N350	Knob style override	350
CE000565	CEBN-070-NAFN-02-S10-N500	Standard	500
CE000566	CEBN-070-NAFP-02-S10-N500	Push style override	500
CE000567	CEBN-070-NAFK-02-S10-N500	Knob style override	500

SOLENOID OPERATED CARTRIDGE

CEBN-100-NAFN

**PILOT OPERATED
POPPET TYPE**

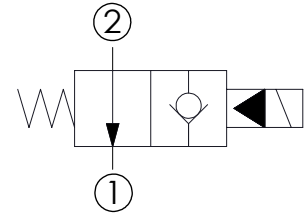
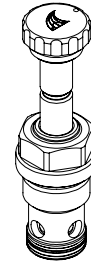
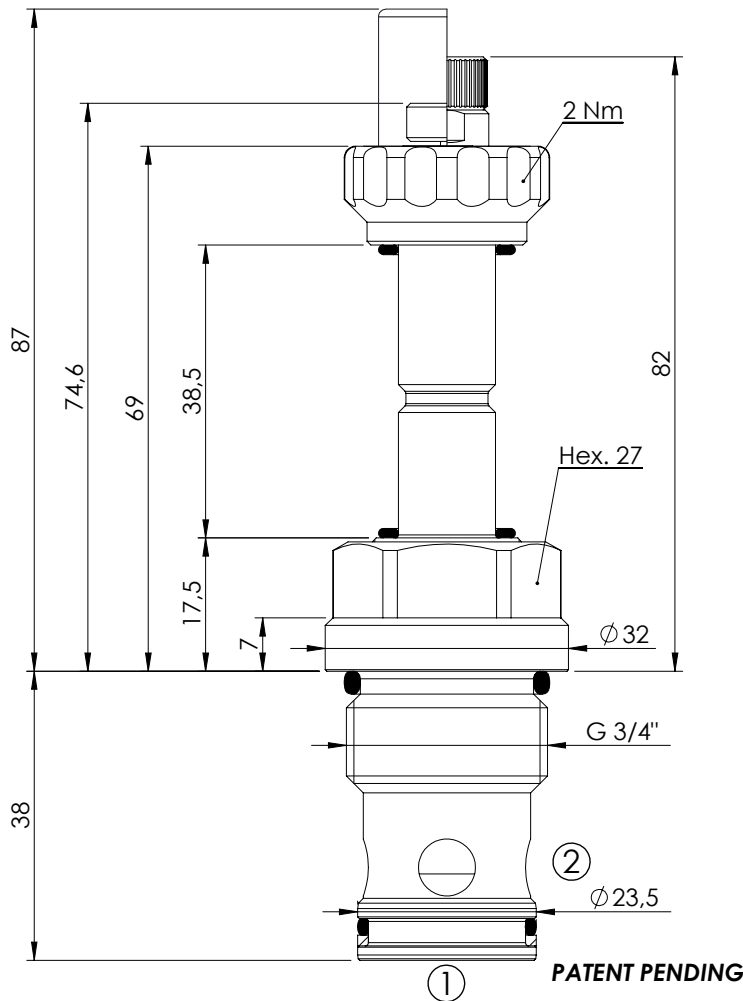



SPECIFICATIONS

Max. operating pressure:	350/500 bar
Rated flow:	100 l/min
Cavity:	VP000057
Weight:	0,25 kg
Min. voltage required:	90% of nominal
Coil type:	M7 type
Seal kit:	RC900057

NOTES

Installation torque: 110 - 130 Nm

OPTIONS

-  Standard
-  Push style override
-  Knob style override

SEALING CAP

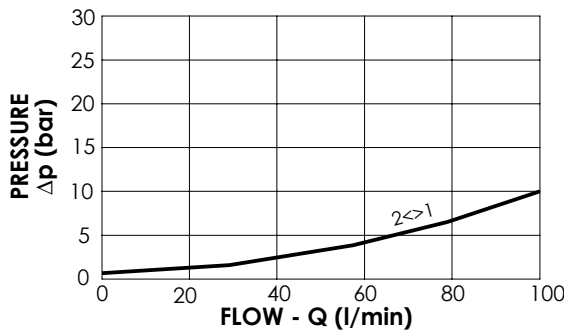
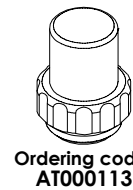

ORDERING CODES

Quick code	Description	Options	Max operating pressure (bar)
CE000300	CEBN-100-NAFN-02-057-N350	Standard	350
CE000301	CEBN-100-NAFP-02-057-N350	Push style override	350
CE000302	CEBN-100-NAFK-02-057-N350	Knob style override	350
CE000600	CEBN-100-NAFN-02-057-N500	Standard	500
CE000601	CEBN-100-NAFP-02-057-N500	Push style override	500
CE000602	CEBN-100-NAFK-02-057-N500	Knob style override	500

SOLENOID OPERATED CARTRIDGE

CEBN-180-NAFN

**PILOT OPERATED
POPPET TYPE**

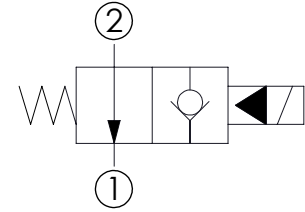
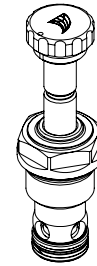
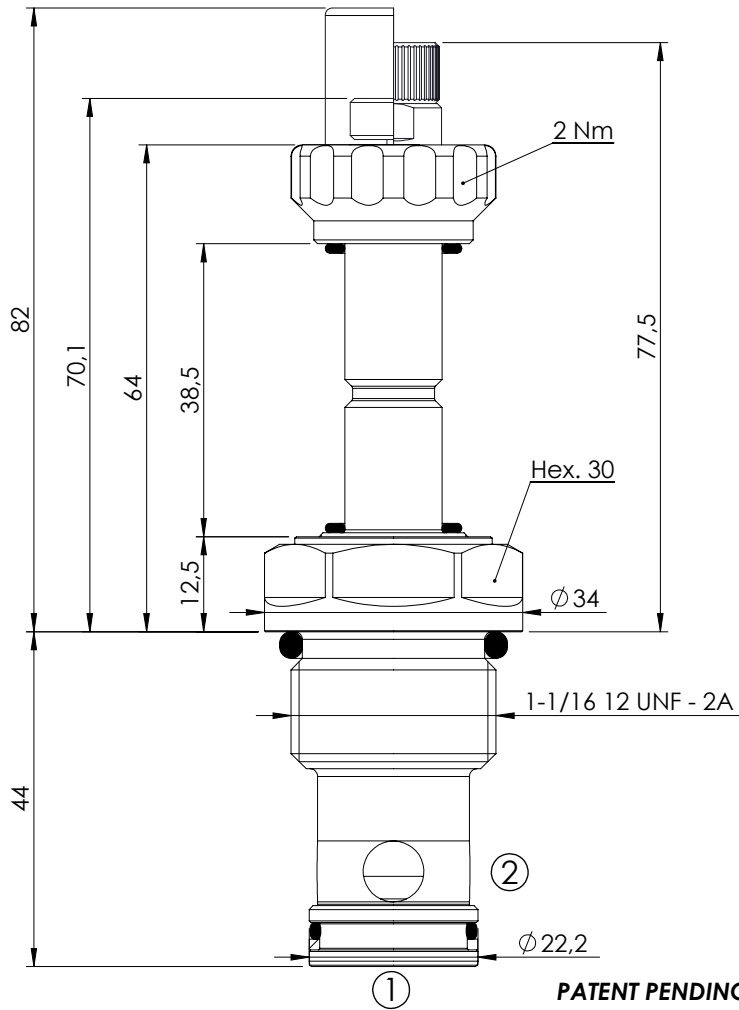

SPECIFICATIONS

Max. operating pressure:	350/500 bar
Rated flow:	180 l/min
Cavity:	SAE-12-2N
Weight:	0,25 kg
Min. voltage required:	90% of nominal
Coil type:	M7 type
Seal kit:	RA900083

NOTES

Installation torque: 135 - 150 Nm

OPTIONS

- Standard
- Push style override
- Knob style override

SEALING CAP

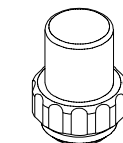

Ordering code:
AT000113

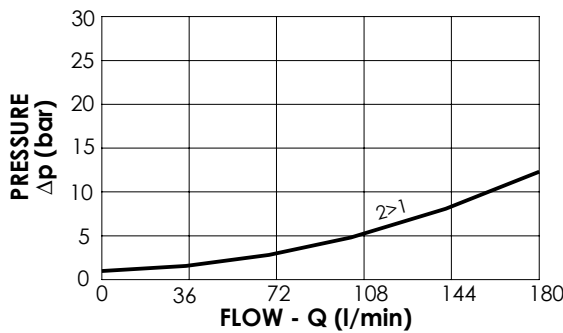

ORDERING CODES

Quick code	Description	Options	Max operating pressure (bar)
CE000335	CEBN-180-NAFN-02-S12-N350	Standard	350
CE000336	CEBN-180-NAFP-02-S12-N350	Push style override	350
CE000337	CEBN-180-NAFK-02-S12-N350	Knob style override	350
CE000635	CEBN-180-NAFN-02-S12-N500	Standard	500
CE000636	CEBN-180-NAFP-02-S12-N500	Push style override	500
CE000637	CEBN-180-NAFK-02-S12-N500	Knob style override	500

SOLENOID OPERATED CARTRIDGE

CEBN-200-NAFN

**PILOT OPERATED
POPPET TYPE**

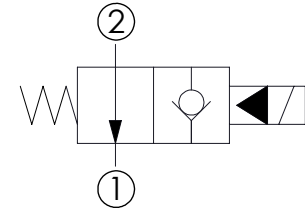
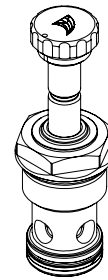
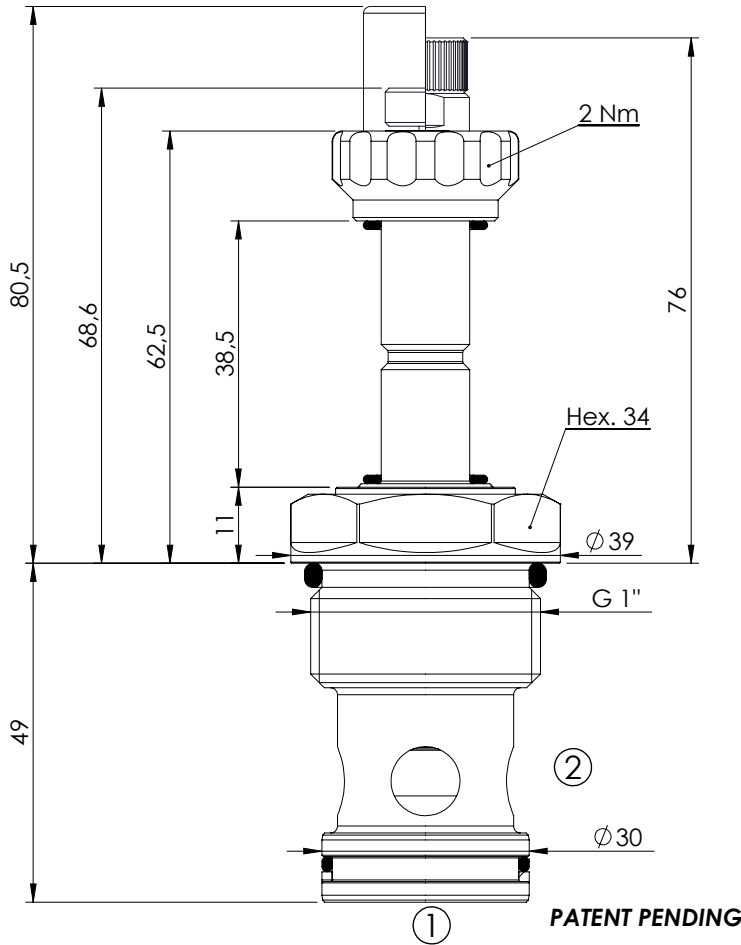



SPECIFICATIONS

Max. operating pressure:	350/500 bar
Rated flow:	200 l/min
Cavity:	VP000013
Weight:	0,35 kg
Min. voltage required:	90% of nominal
Coil type:	M7 type
Seal kit:	RC900013

NOTES

Installation torque: 135 - 150 Nm

OPTIONS

-  Standard
-  Push style override
-  Knob style override

SEALING CAP

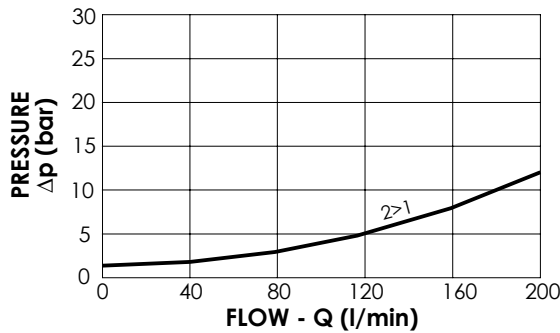
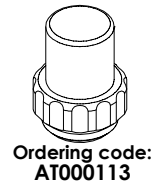

ORDERING CODES

Quick code	Description	Options	Max operating pressure (bar)
CE000370	CEBN-200-NAFN-02-013-N350	Standard	350
CE000371	CEBN-200-NAFP-02-013-N350	Push style override	350
CE000372	CEBN-200-NAFK-02-013-N350	Knob style override	350
CE000670	CEBN-200-NAFN-02-013-N500	Standard	500
CE000671	CEBN-200-NAFP-02-013-N500	Push style override	500
CE000672	CEBN-200-NAFK-02-013-N500	Knob style override	500

SOLENOID OPERATED CARTRIDGE

CEBN-300-NAFN

**PILOT OPERATED
POPPET TYPE**

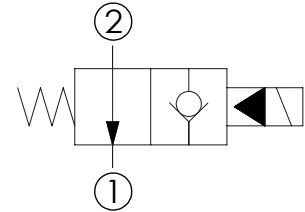
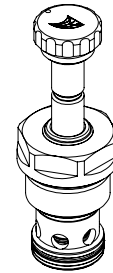
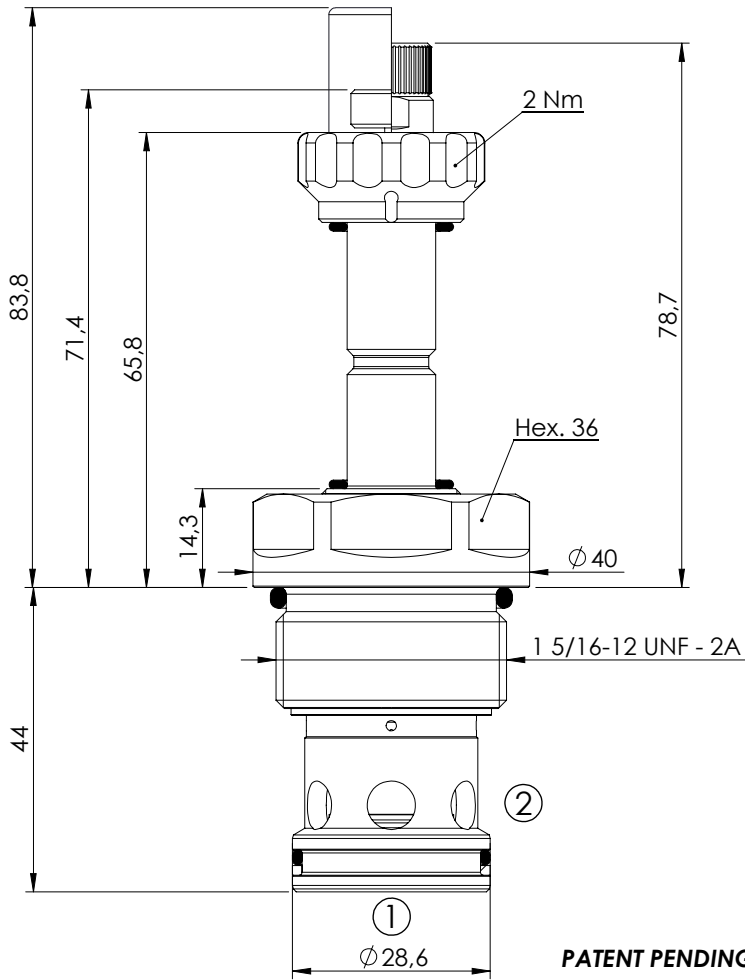

SPECIFICATIONS



Max. operating pressure:	350/500 bar
Rated flow:	300 l/min
Cavity:	SAE-16-2N
Weight:	0,36 kg
Min. voltage required:	90% of nominal
Coil type:	M7 type
Seal kit:	RA900084

NOTES

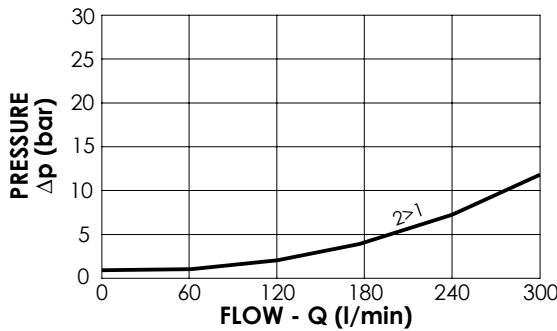
Installation torque: 118 - 132 Nm



OPTIONS

-  Standard
-  Push style override
-  Knob style override

SEALING CAP

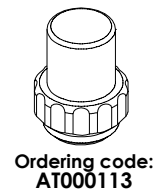

ORDERING CODES

Quick code	Description	Options	Max operating pressure (bar)
CE000405	CEBN-300-NAFN-02-S16-N350	Standard	350
CE000406	CEBN-300-NAFP-02-S16-N350	Push style override	350
CE000407	CEBN-300-NAFK-02-S16-N350	Knob style override	350
CE000705	CEBN-300-NAFN-02-S16-N500	Standard	500
CE000706	CEBN-300-NAFP-02-S16-N500	Push style override	500
CE000707	CEBN-300-NAFK-02-S16-N500	Knob style override	500

SOLENOID OPERATED CARTRIDGE

CEBN-030-NAFN

**PILOT OPERATED
POPPET TYPE**

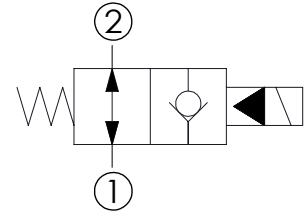
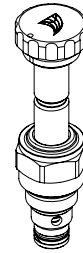
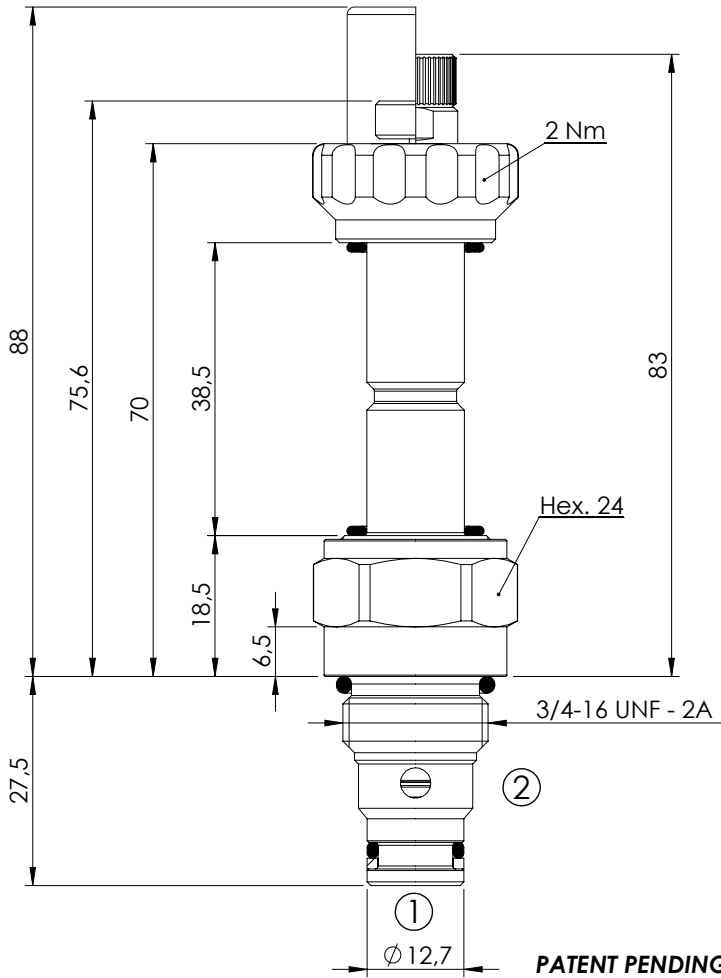

SPECIFICATIONS

Max. operating pressure:	350 bar
Rated flow:	30 l/min
Cavity:	SAE-08-2N
Weight:	0,15 kg
Min. voltage required:	90% of nominal
Coil type:	M7 type
Seal kit:	RA900081

NOTES

Installation torque: 45 - 50 Nm

OPTIONS

- Standard
- Push style override
- Knob style override

SEALING CAP

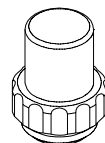

Ordering code:
AT000113

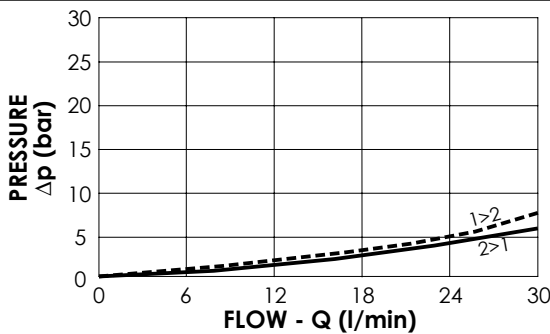

ORDERING CODES

Quick code	Description	Options	Max operating pressure (bar)
CE000464	CEBN-030-NAFN-06-S08-N350	Standard	350
CE000465	CEBN-030-NAFP-06-S08-N350	Push style override	350
CE000466	CEBN-030-NAFK-06-S08-N350	Knob style override	350

SOLENOID OPERATED CARTRIDGE

CEBN-040-NAFN

**PILOT OPERATED
POPPET TYPE**

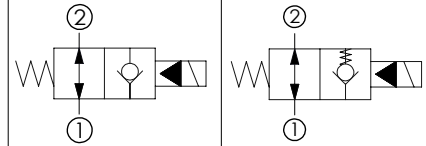
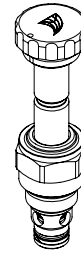
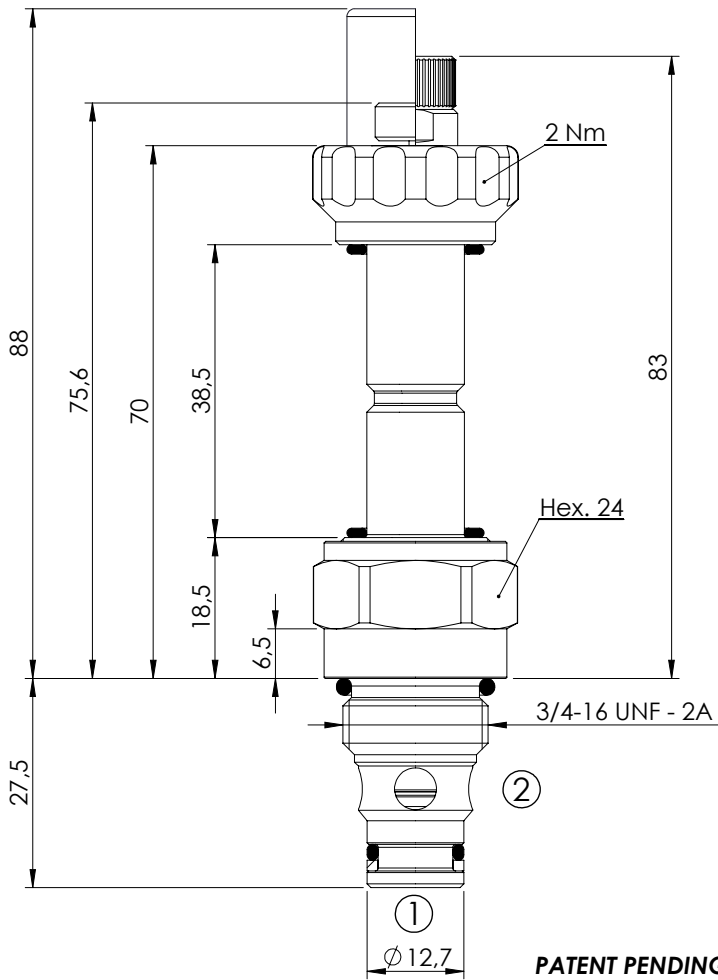

With extra spring

SPECIFICATIONS

Max. operating pressure:	350/500 bar
Rated flow:	40 l/min
Cavity:	SAE-08-2N
Weight:	0,14 kg
Min. voltage required:	90% of nominal
Coil type:	M7 type
Seal kit:	RA900081

NOTES

Installation torque: 45 - 50 Nm

OPTIONS

- Standard
- Push style override
- Knob style override

SEALING CAP

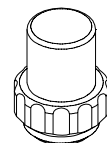

Ordering code:
AT000113

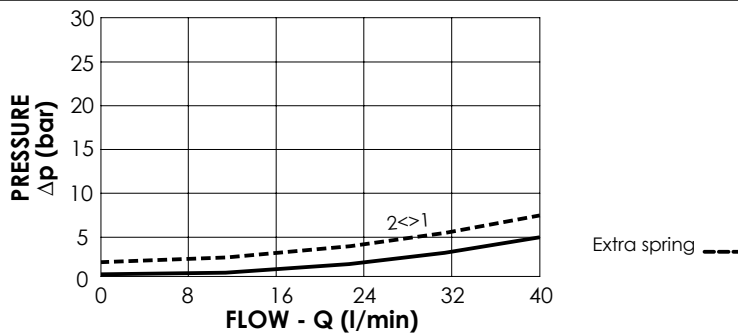

ORDERING CODES

Quick code	Description	Options	Max operating pressure (bar)	Extra spring
CE000236	CEBN-040-NAFN-06-S08-N350	Standard	350	No
CE000237	CEBN-040-NAFP-06-S08-N350	Push style override	350	No
CE000238	CEBN-040-NAFK-06-S08-N350	Knob style override	350	No
CE000483	CEBN-040-XAFN-06-S08-N350	Standard	350	Yes
CE000536	CEBN-040-NAFN-06-S08-N500	Standard	500	No
CE000537	CEBN-040-NAFP-06-S08-N500	Push style override	500	No
CE000538	CEBN-040-NAFK-06-S08-N500	Knob style override	500	No

SOLENOID OPERATED CARTRIDGE

CEBN-070-NAFN

**PILOT OPERATED
POPPET TYPE**

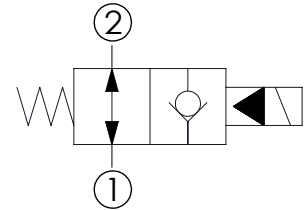
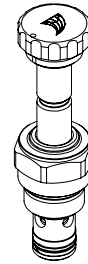
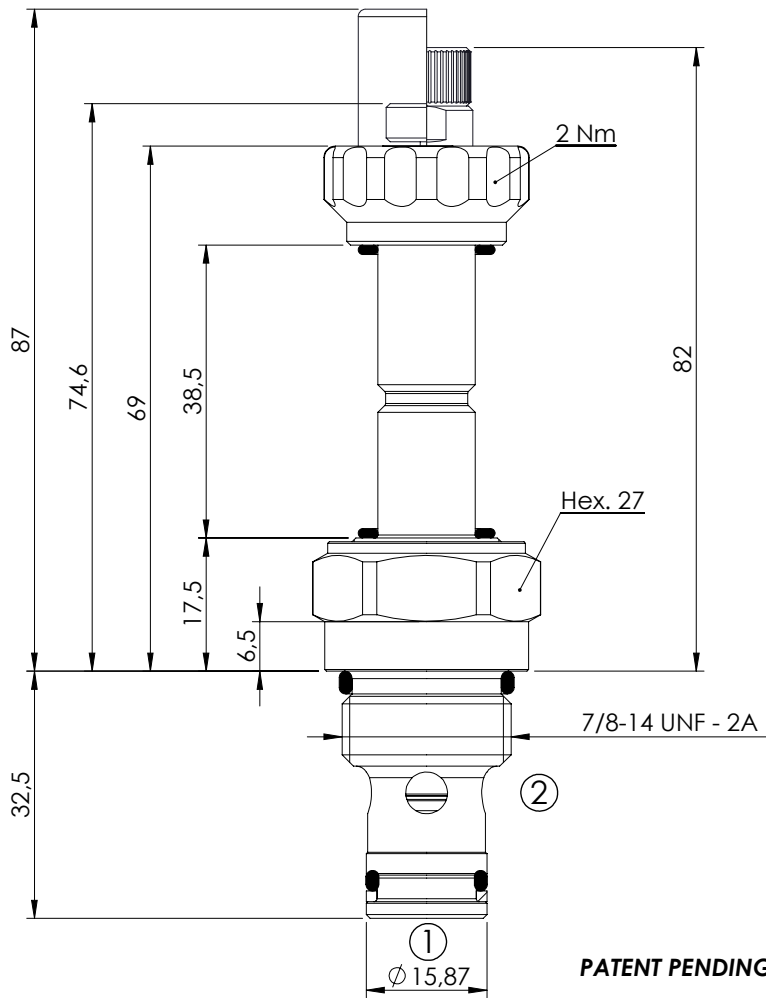

SPECIFICATIONS

Max. operating pressure:	350/500 bar
Rated flow:	70 l/min
Cavity:	SAE-10-2N
Weight:	0,18 kg
Min. voltage required:	90% of nominal
Coil type:	M7 type
Seal kit:	RA900082

NOTES

Installation torque: 55 - 62 Nm

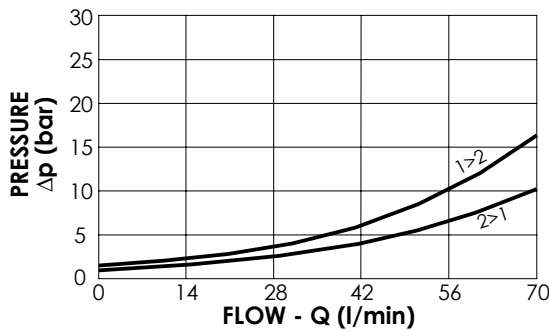

OPTIONS

- Standard
- Push style override
- Knob style override

SEALING CAP

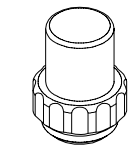

Ordering code: AT000113

ORDERING CODES

Quick code	Description	Options	Max operating pressure (bar)
CE000271	CEBN-070-NAFN-06-S10-N350	Standard	350
CE000272	CEBN-070-NAFP-06-S10-N350	Push style override	350
CE000273	CEBN-070-NAFK-06-S10-N350	Knob style override	350
CE000571	CEBN-070-NAFN-06-S10-N500	Standard	500
CE000572	CEBN-070-NAFP-06-S10-N500	Push style override	500
CE000573	CEBN-070-NAFK-06-S10-N500	Knob style override	500

SOLENOID OPERATED CARTRIDGE

CEBN-100-NAFN

**PILOT OPERATED
POPPET TYPE**

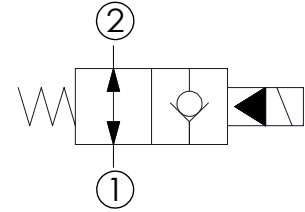
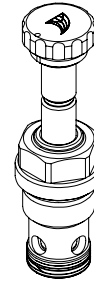
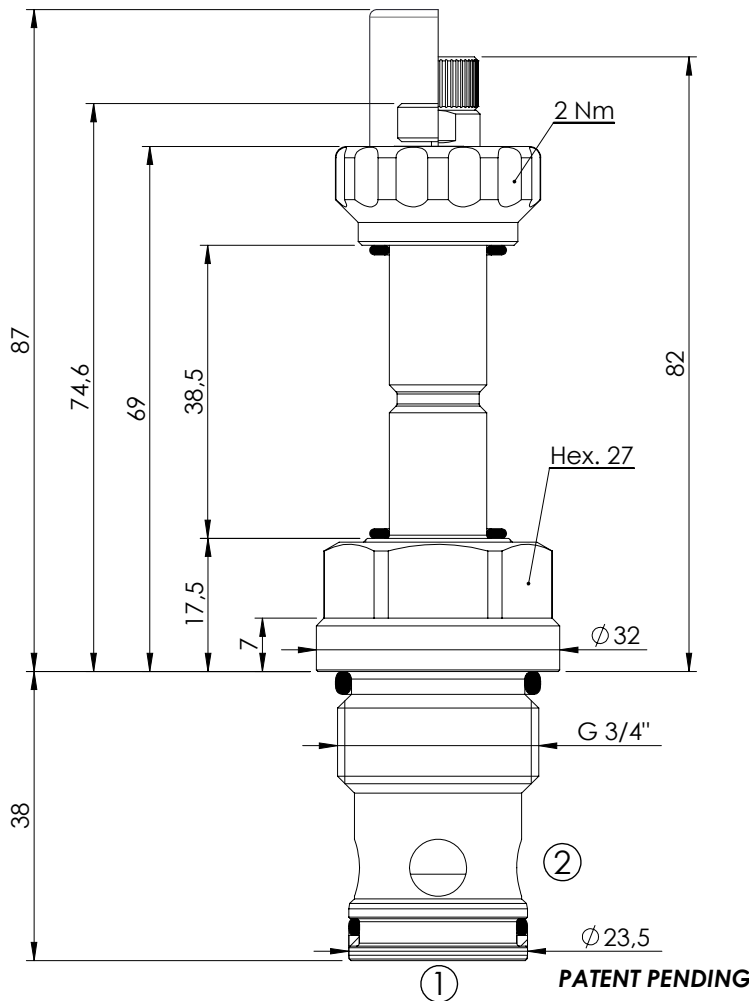

SPECIFICATIONS

Max. operating pressure:	350/500 bar
Rated flow:	100 l/min
Cavity:	VP000057
Weight:	0,25 kg
Min. voltage required:	90% of nominal
Coil type:	M7 type
Seal kit:	RC900057

NOTES

Installation torque: 110 - 130 Nm

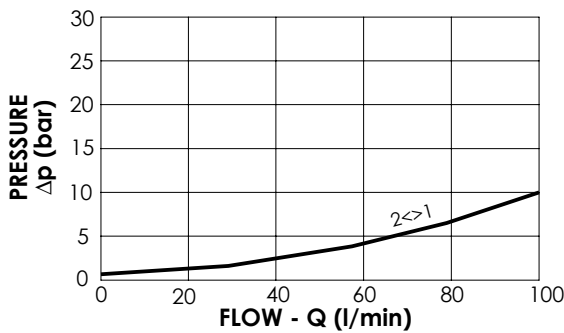

OPTIONS

- Standard
- Push style override
- Knob style override

SEALING CAP

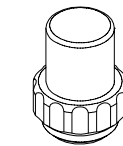

Ordering code:
AT000113

ORDERING CODES

Quick code	Description	Options	Max operating pressure (bar)
CE000306	CEBN-100-NAFN-06-057-N350	Standard	350
CE000307	CEBN-100-NAFP-06-057-N350	Push style override	350
CE000308	CEBN-100-NAFK-06-057-N350	Knob style override	350
CE000606	CEBN-100-NAFN-06-057-N500	Standard	500
CE000607	CEBN-100-NAFP-06-057-N500	Push style override	500
CE000608	CEBN-100-NAFK-06-057-N500	Knob style override	500

SOLENOID OPERATED CARTRIDGE

CEBN-180-NAFN

**PILOT OPERATED
POPPET TYPE**

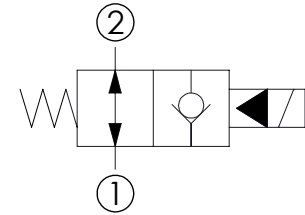
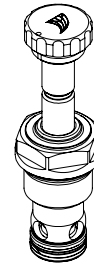
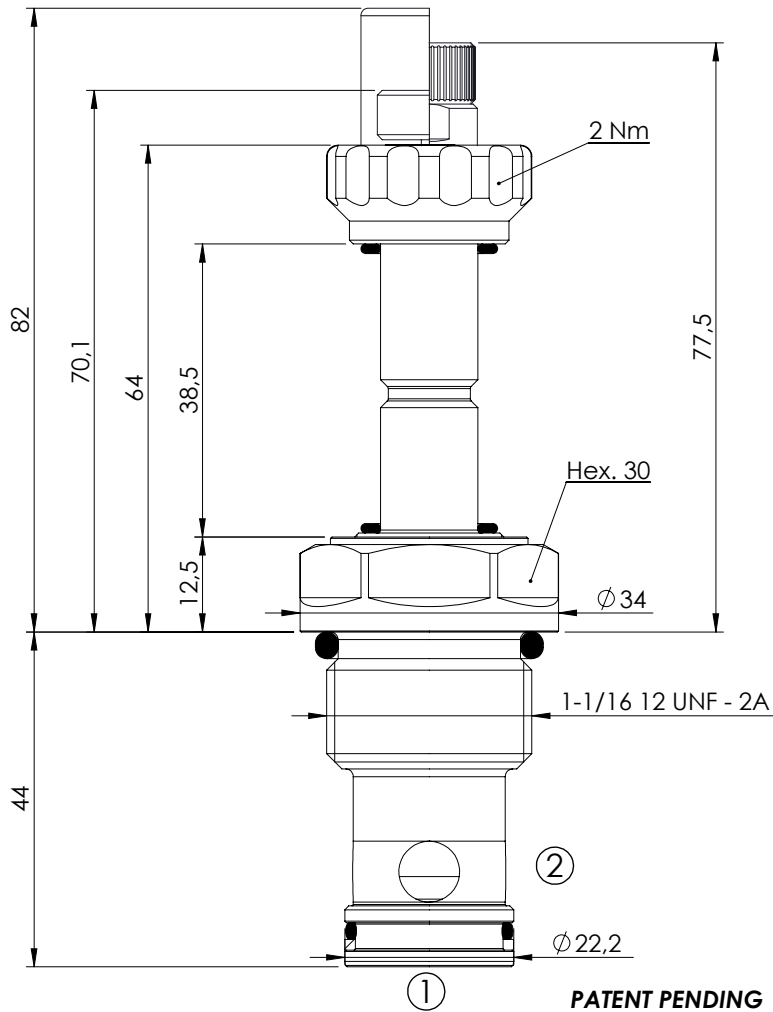

SPECIFICATIONS

Max. operating pressure:	350/500 bar
Rated flow:	180 l/min
Cavity:	SAE-12-2N
Weight:	0,25 kg
Min. voltage required:	90% of nominal
Coil type:	M7 type
Seal kit:	RA900083

NOTES

Installation torque: 135 - 150 Nm

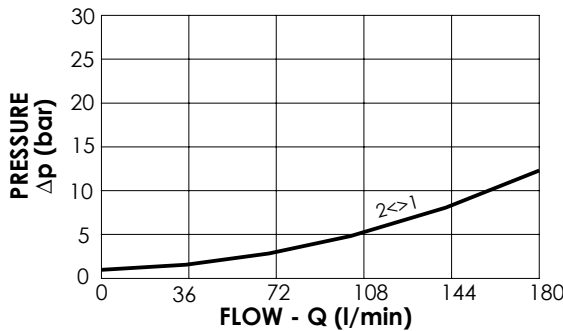

OPTIONS

- Standard
- Push style override
- Knob style override

SEALING CAP

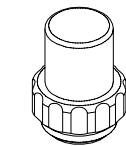

Ordering code:
AT000113

ORDERING CODES

Quick code	Description	Options	Max operating pressure (bar)
CE000341	CEBN-180-NAFN-06-S12-N350	Standard	350
CE000342	CEBN-180-NAFP-06-S12-N350	Push style override	350
CE000343	CEBN-180-NAFK-06-S12-N350	Knob style override	350
CE000641	CEBN-180-NAFN-06-S12-N500	Standard	500
CE000642	CEBN-180-NAFP-06-S12-N500	Push style override	500
CE000643	CEBN-180-NAFK-06-S12-N500	Knob style override	500

SOLENOID OPERATED CARTRIDGE

CEBN-200-NAFN

**PILOT OPERATED
POPPET TYPE**

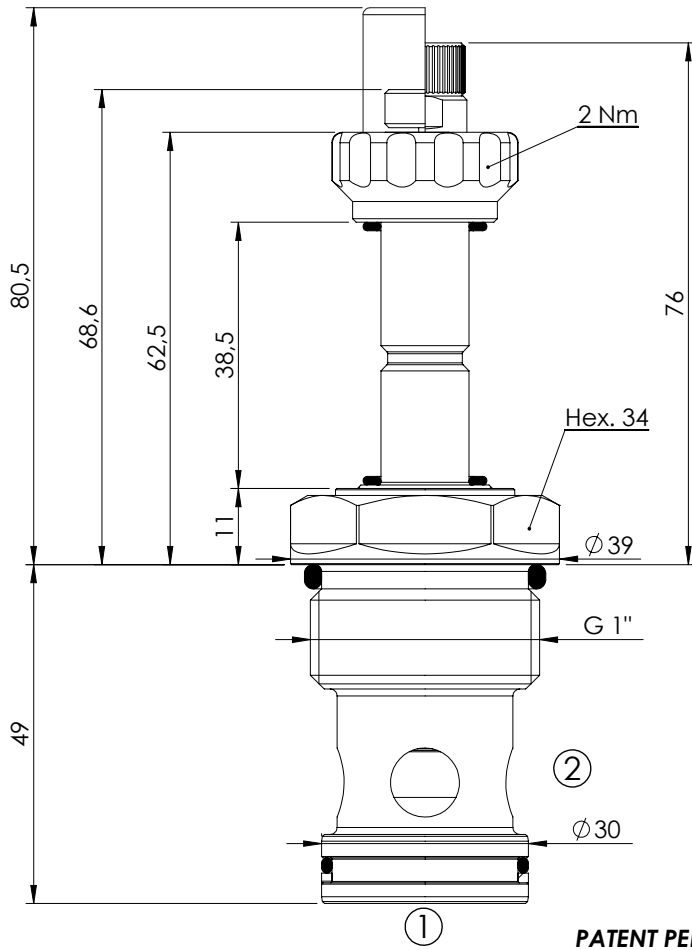

PATENT PENDING

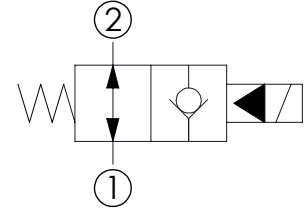
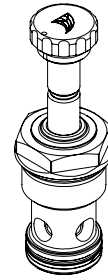

SPECIFICATIONS



Max. operating pressure:	350/500 bar
Rated flow:	200 l/min
Cavity:	VP000013
Weight:	0,35 kg
Min. voltage required:	90% of nominal
Coil type:	M7 type
Seal kit:	RC900013

NOTES

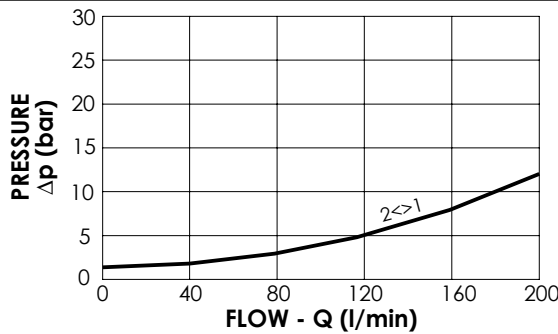
Installation torque: 135 - 150 Nm



OPTIONS

-  Standard
-  Push style override
-  Knob style override

SEALING CAP

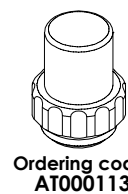

ORDERING CODES

Quick code	Description	Options	Max operating pressure (bar)
CE000376	CEBN-200-NAFN-06-013-N350	Standard	350
CE000377	CEBN-200-NAFP-06-013-N350	Push style override	350
CE000378	CEBN-200-NAFK-06-013-N350	Knob style override	350
CE000676	CEBN-200-NAFN-06-013-N500	Standard	500
CE000677	CEBN-200-NAFP-06-013-N500	Push style override	500
CE000678	CEBN-200-NAFK-06-013-N500	Knob style override	500

SOLENOID OPERATED CARTRIDGE

CEBN-300-NAFN

**PILOT OPERATED
POPPET TYPE**

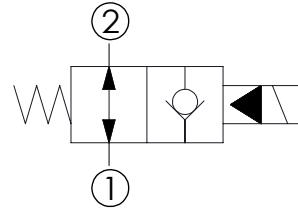
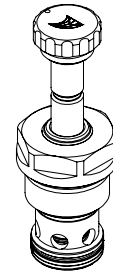
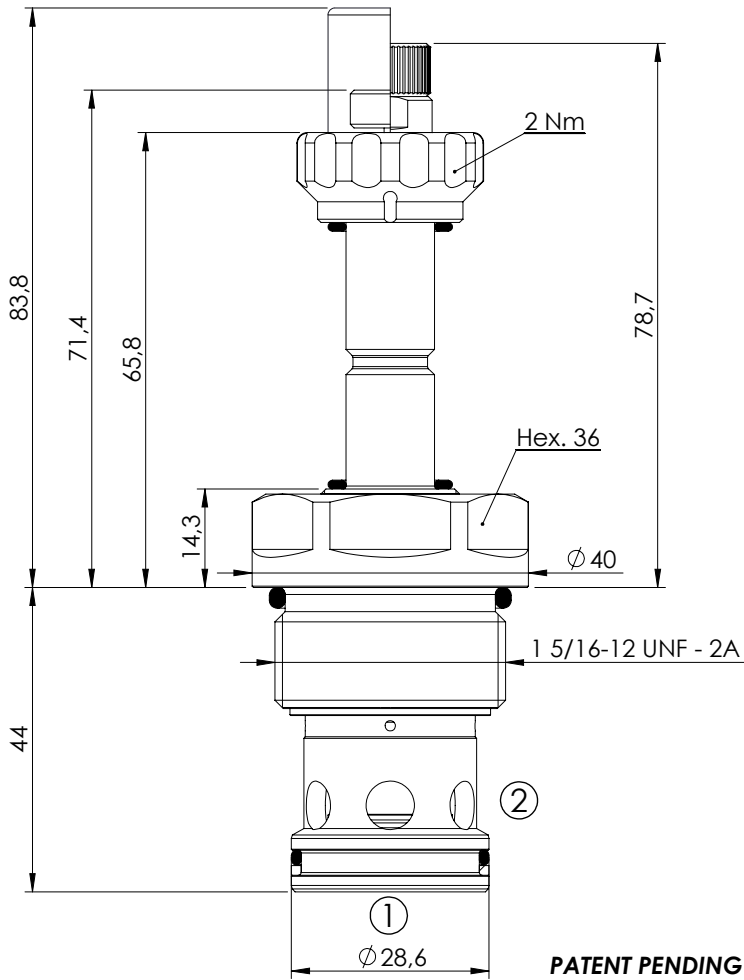

SPECIFICATIONS

Max. operating pressure:	350/500 bar
Rated flow:	300 l/min
Cavity:	SAE-16-2N
Weight:	0,36 kg
Min. voltage required:	90% of nominal
Coil type:	M7 type
Seal kit:	RA900084

NOTES

Installation torque: 118 - 132 Nm

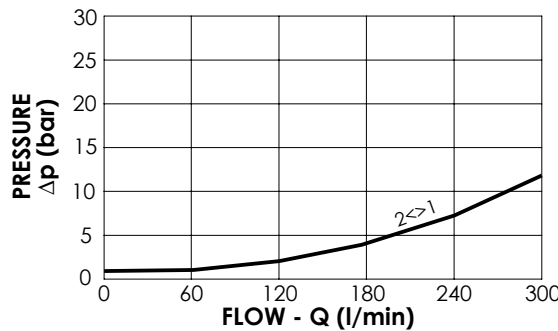

OPTIONS

- Standard
- Push style override
- Knob style override

SEALING CAP

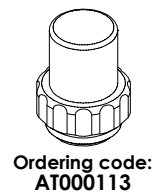

ORDERING CODES

Quick code	Description	Options	Max operating pressure (bar)
CE000411	CEBN-300-NAFN-06-S16-N350	Standard	350
CE000412	CEBN-300-NAFP-06-S16-N350	Push style override	350
CE000413	CEBN-300-NAFK-06-S16-N350	Knob style override	350
CE000711	CEBN-300-NAFN-06-S16-N500	Standard	500
CE000712	CEBN-300-NAFP-06-S16-N500	Push style override	500
CE000713	CEBN-300-NAFK-06-S16-N500	Knob style override	500

SOLENOID OPERATED CARTRIDGE

CEBN-040-NAFN

**PILOT OPERATED
POPPET TYPE**

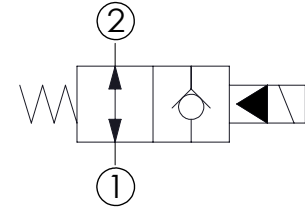
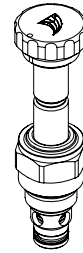
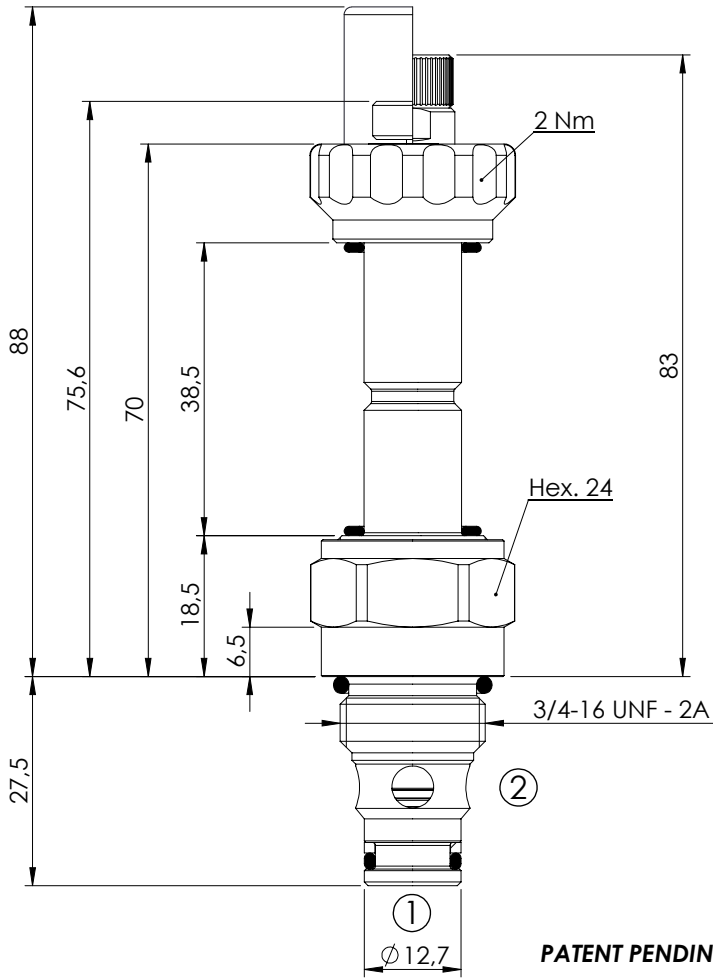

SPECIFICATIONS

Max. operating pressure:	350/500 bar
Rated flow:	40 l/min
Cavity:	SAE-08-2N
Weight:	0,14 kg
Min. voltage required:	90% of nominal
Coil type:	M7 type
Seal kit:	RA900081

NOTES

Installation torque: 45 - 50 Nm

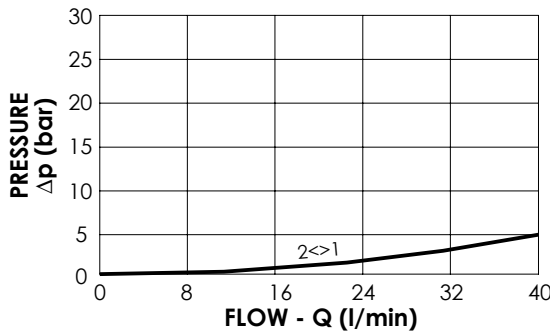

OPTIONS

- Standard
- Push style override
- Knob style override

SEALING CAP

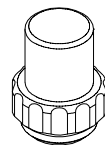

Ordering code:
AT000113

ORDERING CODES

Quick code	Description	Options	Max operating pressure (bar)
CE000233	CEBN-040-NAFN-04-S08-N350	Standard	350
CE000234	CEBN-040-NAFP-04-S08-N350	Push style override	350
CE000235	CEBN-040-NAFK-04-S08-N350	Knob style override	350
CE000533	CEBN-040-NAFN-04-S08-N500	Standard	500
CE000534	CEBN-040-NAFP-04-S08-N500	Push style override	500
CE000535	CEBN-040-NAFK-04-S08-N500	Knob style override	500

SOLENOID OPERATED CARTRIDGE

CEBN-070-NAFN

**PILOT OPERATED
POPPET TYPE**

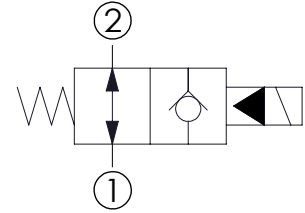
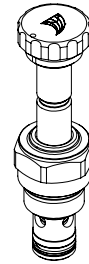
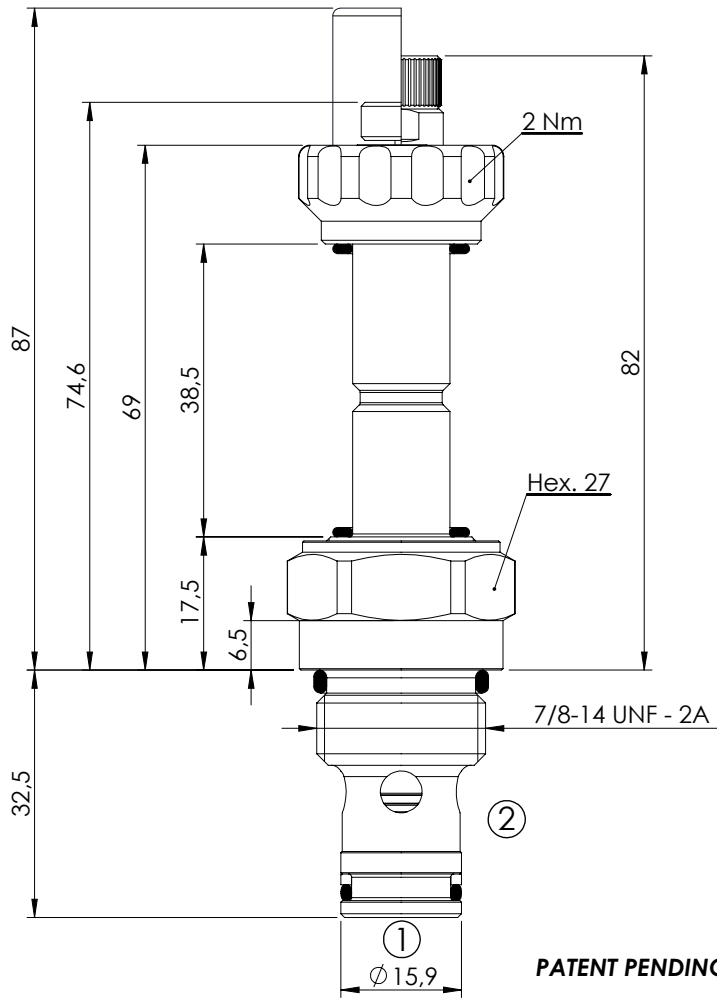

SPECIFICATIONS

Max. operating pressure:	350 bar
Rated flow:	70 l/min
Cavity:	SAE-10-2N
Weight:	0,18 kg
Min. voltage required:	90% of nominal
Coil type:	M7 type
Seal kit:	RA900082

NOTES

Installation torque: 55 - 62 Nm

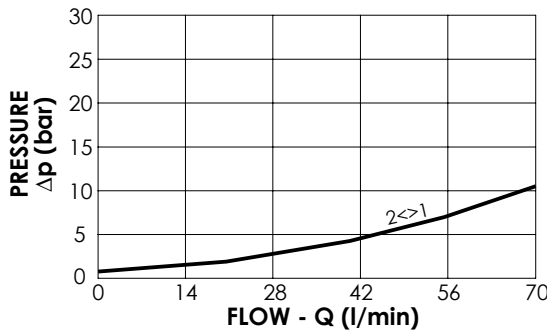

OPTIONS

- Standard
- Push style override
- Knob style override

SEALING CAP

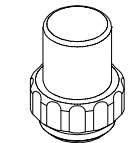

Ordering code:
AT000113

ORDERING CODES

Quick code	Description	Options	Max operating pressure (bar)
CE000268	CEBN-070-NAFN-04-S10-N350	Standard	350
CE000269	CEBN-070-NAFP-04-S10-N350	Push style override	350
CE000270	CEBN-070-NAFK-04-S10-N350	Knob style override	350
CE000568	CEBN-070-NAFN-04-S10-N500	Standard	500
CE000569	CEBN-070-NAFP-04-S10-N500	Push style override	500
CE000570	CEBN-070-NAFK-04-S10-N500	Knob style override	500

SOLENOID OPERATED CARTRIDGE

CEBN-100-NAFN

**PILOT OPERATED
POPPET TYPE**

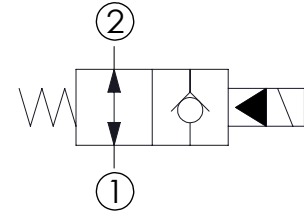
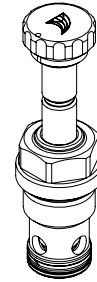
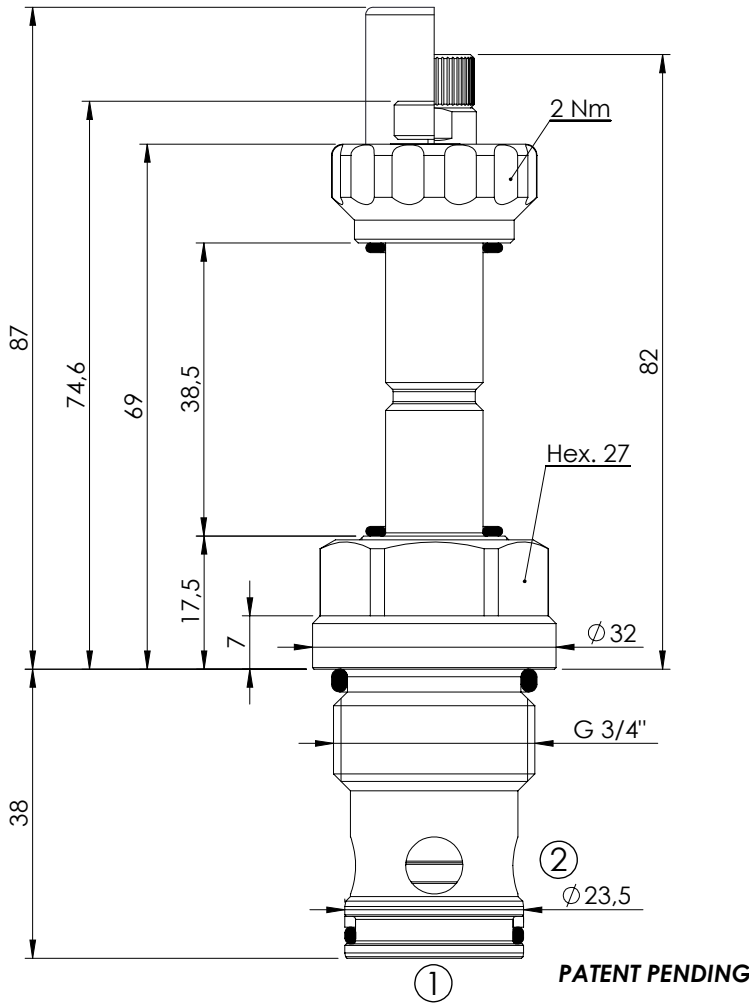

SPECIFICATIONS

Max. operating pressure:	350/500 bar
Rated flow:	100 l/min
Cavity:	VP000057
Weight:	0,25 kg
Min. voltage required:	90% of nominal
Coil type:	M7 type
Seal kit:	RC900057

NOTES

Installation torque: 110 - 130 Nm

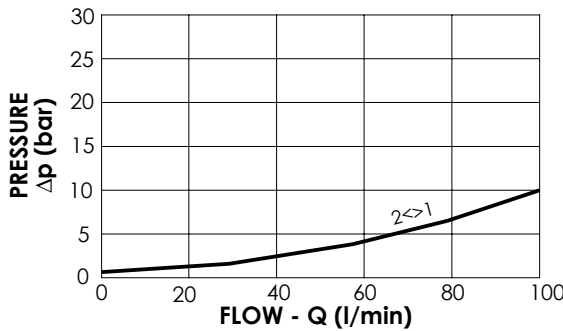

OPTIONS

- Standard
- Push style override
- Knob style override

SEALING CAP

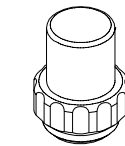

Ordering code:
AT000113

ORDERING CODES

Quick code	Description	Options	Max operating pressure (bar)
CE000303	CEBN-100-NAFN-04-057-N350	Standard	350
CE000304	CEBN-100-NAFP-04-057-N350	Push style override	350
CE000305	CEBN-100-NAFK-04-057-N350	Knob style override	350
CE000603	CEBN-100-NAFN-04-057-N500	Standard	500
CE000604	CEBN-100-NAFP-04-057-N500	Push style override	500
CE000605	CEBN-100-NAFK-04-057-N500	Knob style override	500

SOLENOID OPERATED CARTRIDGE

CEBN-200-NAFN

**PILOT OPERATED
POPPET TYPE**

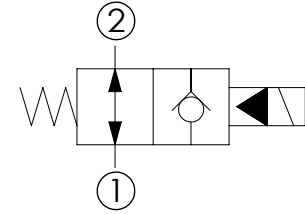
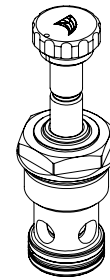
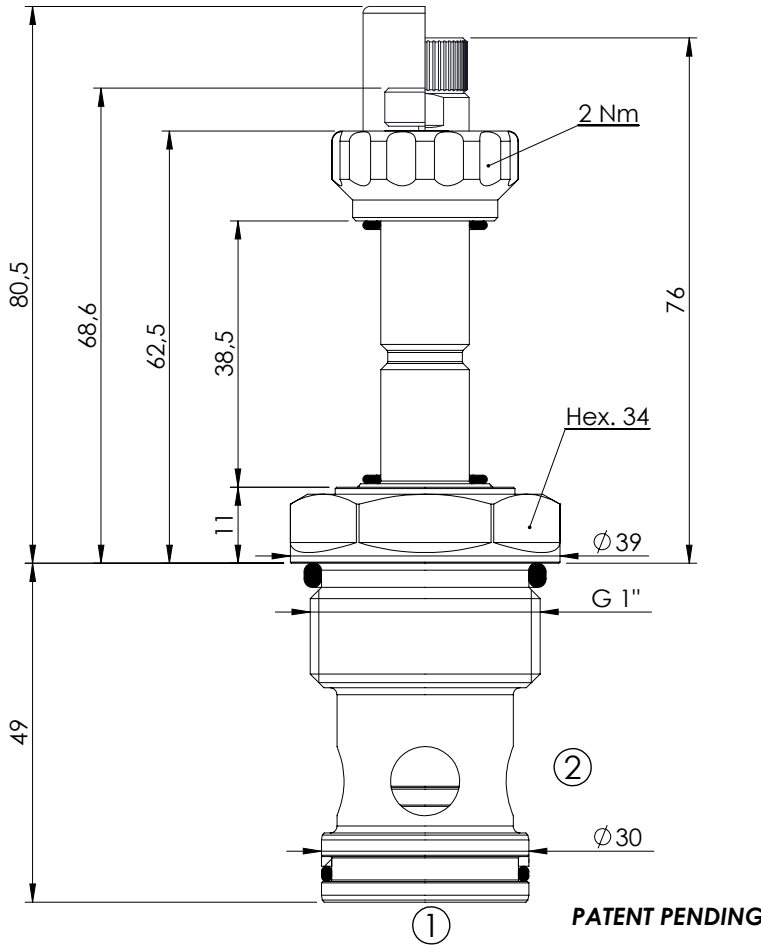

SPECIFICATIONS

Max. operating pressure:	350/500 bar
Rated flow:	200 l/min
Cavity:	VP000013
Weight:	0,35 kg
Min. voltage required:	90% of nominal
Coil type:	M7 type
Seal kit:	RC900013

NOTES

Installation torque: 135 - 150 Nm

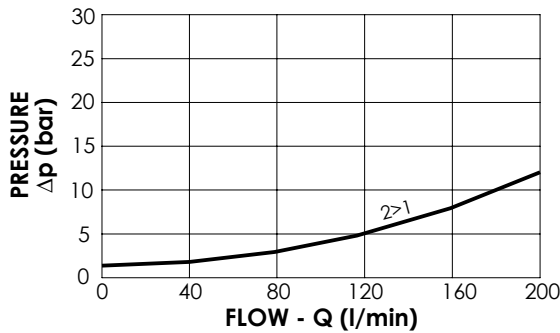

OPTIONS

- Standard
- Push style override
- Knob style override

SEALING CAP

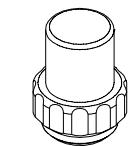

Ordering code:
AT000113

ORDERING CODES

Quick code	Description	Options	Max operating pressure (bar)
CE000373	CEBN-200-NAFN-04-013-N350	Standard	350
CE000374	CEBN-200-NAFP-04-013-N350	Push style override	350
CE000375	CEBN-200-NAFK-04-013-N350	Knob style override	350
CE000673	CEBN-200-NAFN-04-013-N500	Standard	500
CE000674	CEBN-200-NAFP-04-013-N500	Push style override	500
CE000675	CEBN-200-NAFK-04-013-N500	Knob style override	500

SOLENOID OPERATED CARTRIDGE

CEBN-300-NAFN

**PILOT OPERATED
POPPET TYPE**

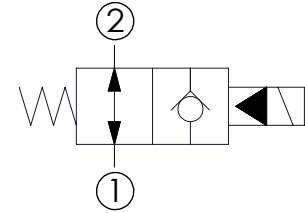
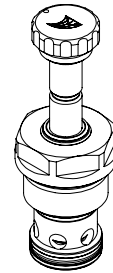
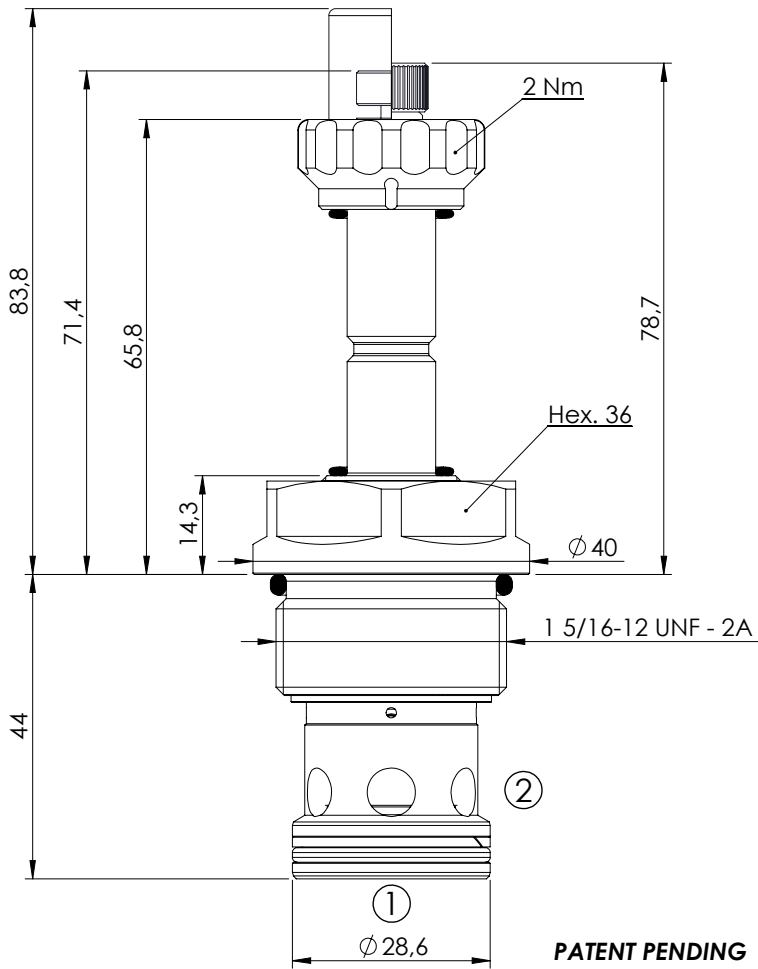

SPECIFICATIONS

Max. operating pressure:	350/500 bar
Rated flow:	300 l/min
Cavity:	SAE-16-2N
Weight:	0,37 kg
Min. voltage required:	90% of nominal
Coil type:	M7 type
Seal kit:	RA700084

NOTES

Installation torque: 118 - 132 Nm

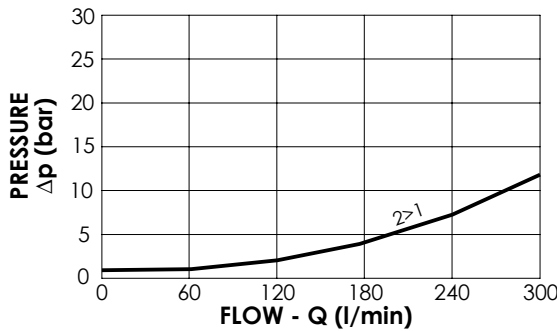

OPTIONS

- Standard
- Push style override
- Knob style override

SEALING CAP

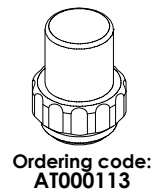

ORDERING CODES

Quick code	Description	Options	Max operating pressure (bar)
CE000408	CEBN-300-NAFN-04-S16-N350	Standard	350
CE000409	CEBN-300-NAFP-04-S16-N350	Push style override	350
CE000410	CEBN-300-NAFK-04-S16-N350	Knob style override	350
CE000708	CEBN-300-NAFN-04-S16-N500	Standard	500
CE000709	CEBN-300-NAFP-04-S16-N500	Push style override	500
CE000710	CEBN-300-NAFK-04-S16-N500	Knob style override	500

SOLENOID OPERATED CARTRIDGE

CEBN-040-NCFN

**PILOT OPERATED
POPPET TYPE**

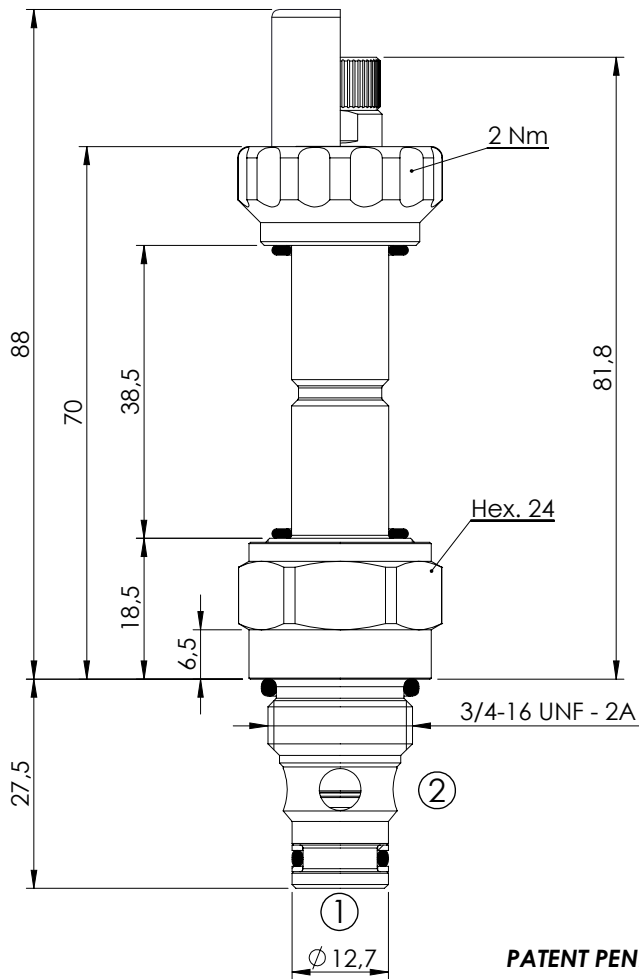

PATENT PENDING

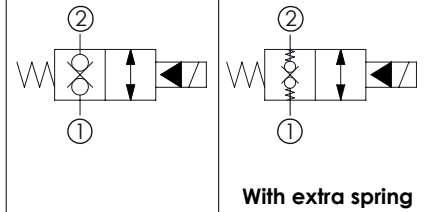
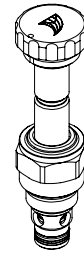

SPECIFICATIONS

Max. operating pressure:	350/500 bar
Rated flow:	40 l/min
Cavity:	SAE-08-2N
Weight:	0,14 kg
Min. voltage required:	90% of nominal
Coil type:	M7 type
Seal kit:	RB900081

NOTES

Installation torque: 45 - 50 Nm

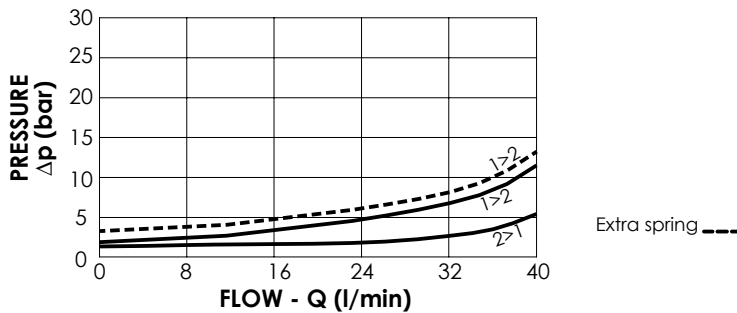

OPTIONS

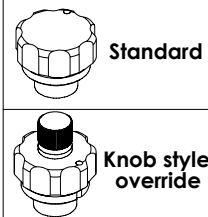

SEALING CAP

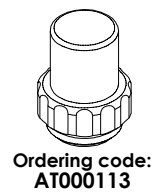

ORDERING CODES

Quick code	Description	Options	Max operating pressure (bar)	Extra Spring
CE000226	CEBN-040-NCFN-31-S08-N350	Standard	350	No
CE000228	CEBN-040-NCFK-31-S08-N350	Knob style override	350	No
CE000227	CEBN-040-XCFN-31-S08-N350	Standard	350	Yes
CE000229	CEBN-040-XCFK-31-S08-N350	Knob style override	350	Yes
CE000526	CEBN-040-NCFN-31-S08-N500	Standard	500	No
CE000528	CEBN-040-NCFK-31-S08-N500	Knob style override	500	No

SOLENOID OPERATED CARTRIDGE

CEBN-070-NCFN

**PILOT OPERATED
POPPET TYPE**

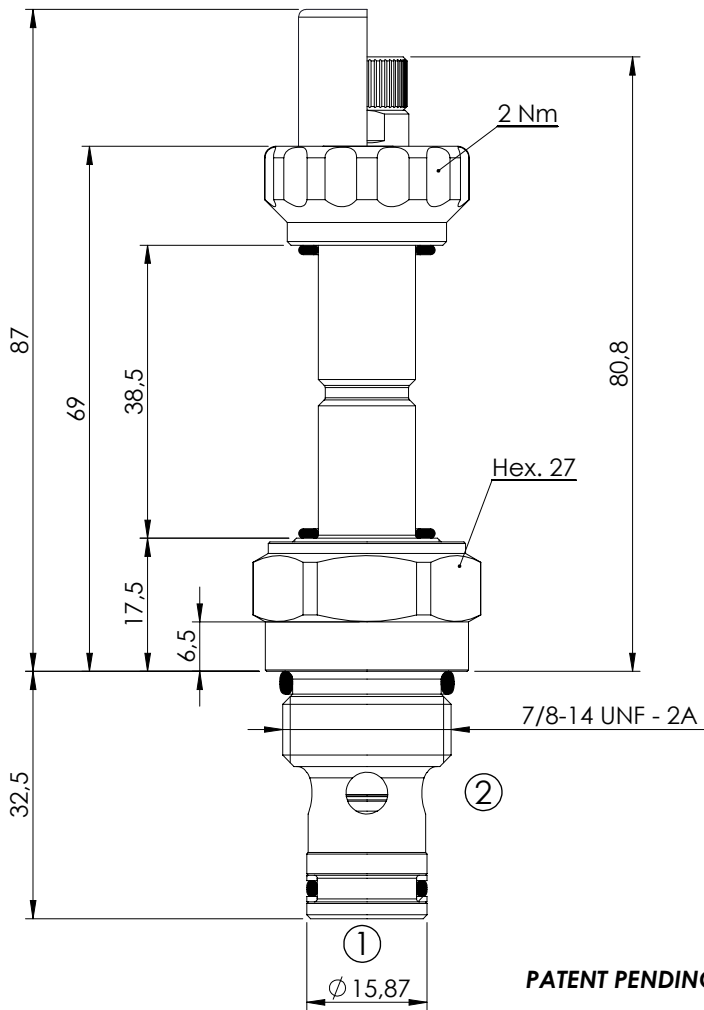

PATENT PENDING

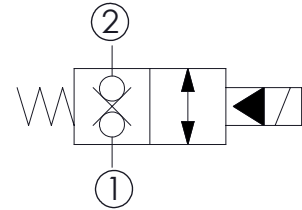
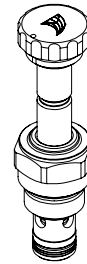

SPECIFICATIONS

Max. operating pressure:	350/500 bar
Rated flow:	70 l/min
Cavity:	SAE-10-2N
Weight:	0,18 kg
Min. voltage required:	90% of nominal
Coil type:	M7 type
Seal kit:	RB900082

NOTES

Installation torque: 55 - 62 Nm

OPTIONS

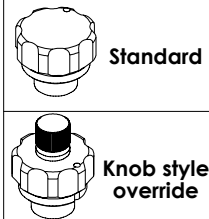

SEALING CAP

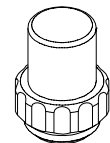

Ordering code:
AT000113

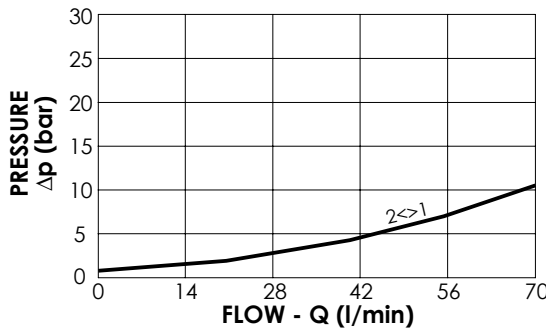

ORDERING CODES

Quick code	Description	Options	Max operating pressure (bar)
CE000261	CEBN-070-NCFN-31-S10-N350	Standard	350
CE000263	CEBN-070-NCFK-31-S10-N350	Knob style override	350
CE000561	CEBN-070-NCFN-31-S10-N500	Standard	500
CE000563	CEBN-070-NCFK-31-S10-N500	Knob style override	500

SOLENOID OPERATED CARTRIDGE

CEBN-100-NCFN

**PILOT OPERATED
POPPET TYPE**

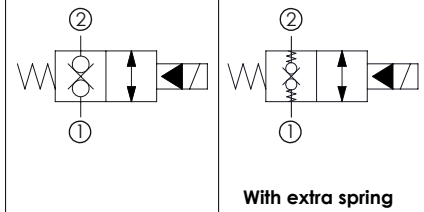
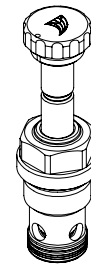
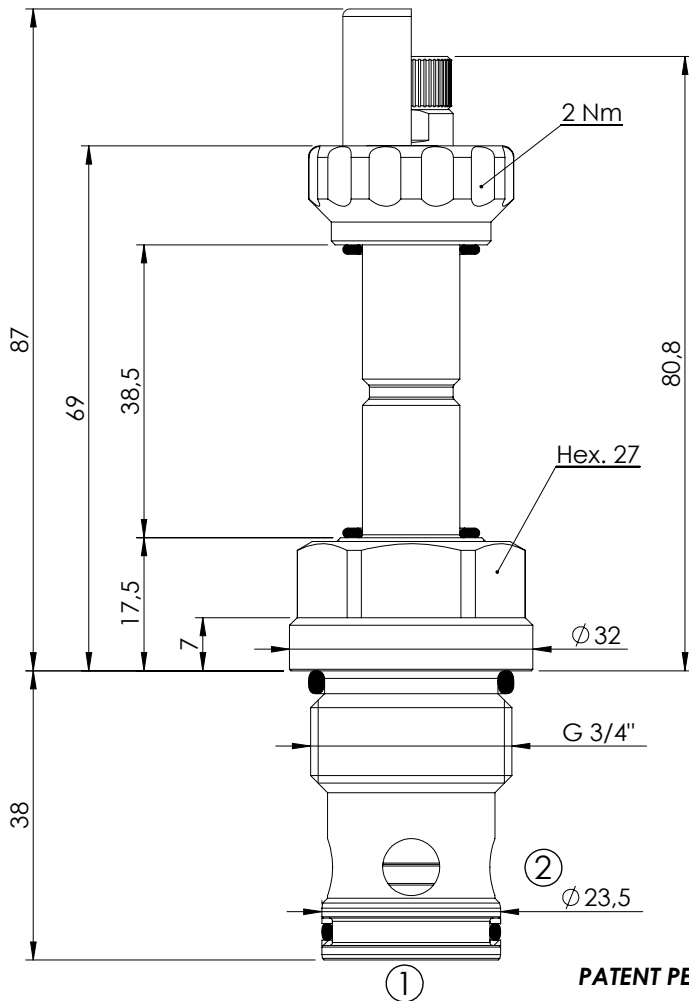

SPECIFICATIONS

Max. operating pressure:	350/500 bar
Rated flow:	100 l/min
Cavity:	VP000057
Weight:	0,25 kg
Min. voltage required:	90% of nominal
Coil type:	M7 type
Seal kit:	RD900057

NOTES

Installation torque: 110 - 130 Nm

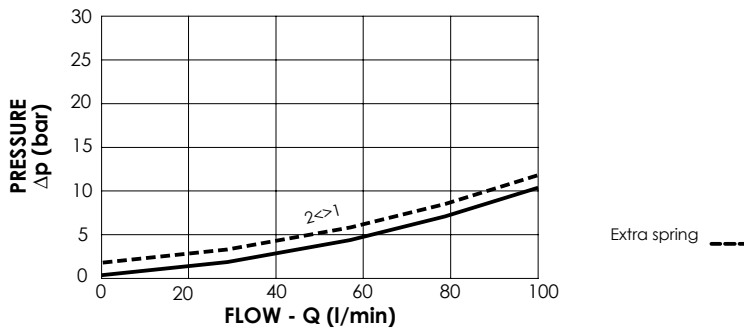

OPTIONS

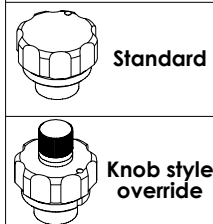

SEALING CAP

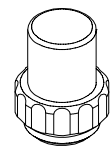

Ordering code:
AT000113

ORDERING CODES

Quick code	Description	Options	Max operating pressure (bar)	Extra Spring
CE000296	CEBN-100-NCFN-31-057-N350	Standard	350	No
CE000298	CEBN-100-NCFK-31-057-N350	Knob style override	350	No
CE000297	CEBN-100-XCFN-31-057-N350	Standard	350	Yes
CE000299	CEBN-100-XCFK-31-057-N350	Knob style override	350	Yes
CE000596	CEBN-100-NCFN-31-057-N500	Standard	500	No
CE000598	CEBN-100-NCFK-31-057-N500	Knob style override	500	No

SOLENOID OPERATED CARTRIDGE

CEBN-180-NCFN

**PILOT OPERATED
POPPET TYPE**

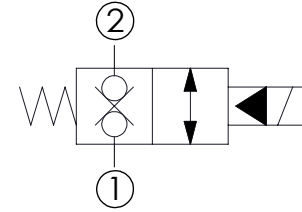
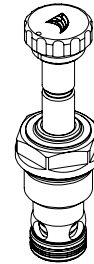
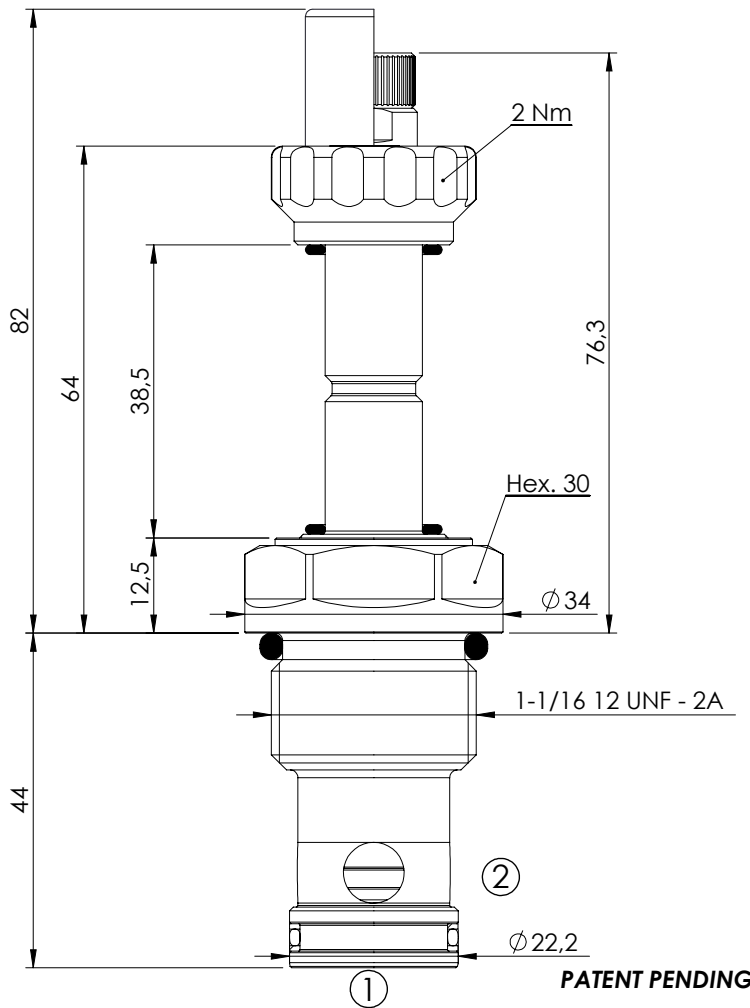

SPECIFICATIONS

Max. operating pressure:	350/500 bar
Rated flow:	180 l/min
Cavity:	SAE-12-2N
Weight:	0,25 kg
Min. voltage required:	90% of nominal
Coil type:	M7 type
Seal kit:	RB900083

NOTES

Installation torque: 135 - 150 Nm

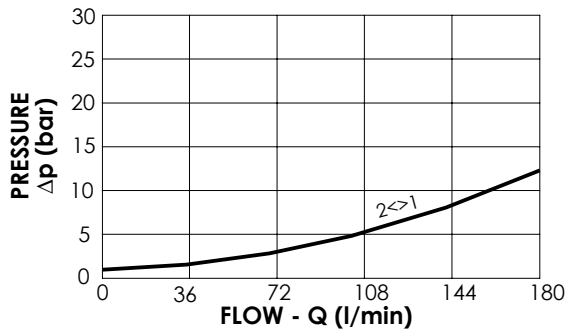

OPTIONS

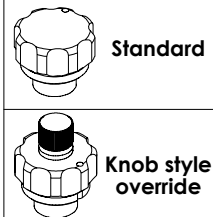

SEALING CAP

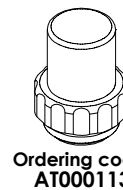

ORDERING CODES

Quick code	Description	Options	Max operating pressure (bar)
CE000331	CEBN-180-NCFN-31-S12-N350	Standard	350
CE000333	CEBN-180-NCFK-31-S12-N350	Knob style override	350
CE000631	CEBN-180-NCFN-31-S12-N500	Standard	500
CE000633	CEBN-180-NCFK-31-S12-N500	Knob style override	500

SOLENOID OPERATED CARTRIDGE

CEBN-200-NCFN

**PILOT OPERATED
POPPET TYPE**

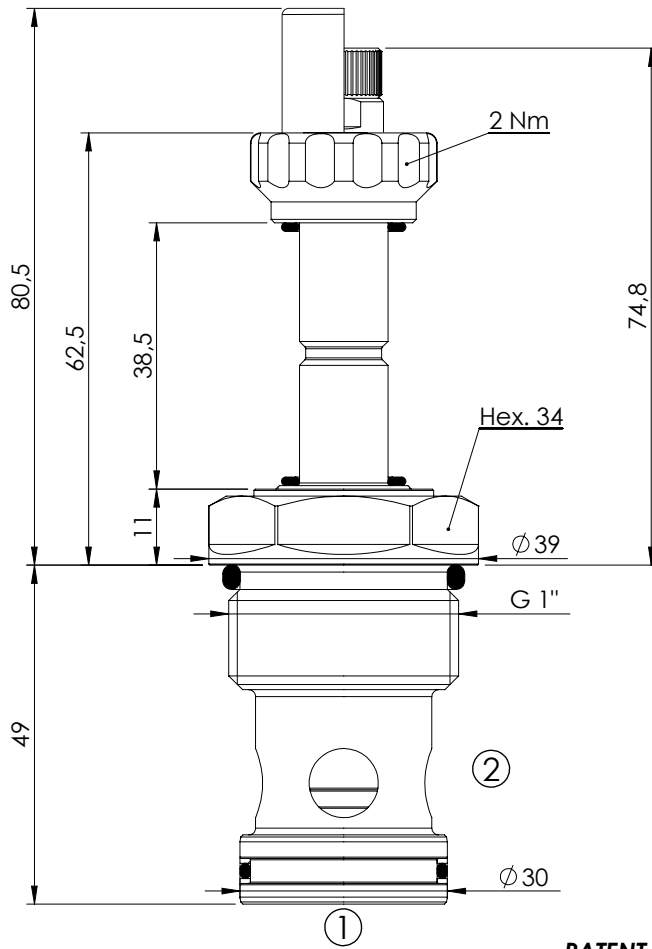

PATENT PENDING

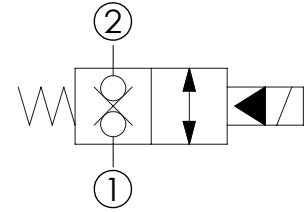
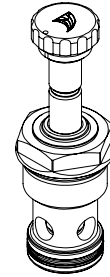

SPECIFICATIONS

Max. operating pressure:	350/500 bar
Rated flow:	200 l/min
Cavity:	VP000013
Weight:	0,35 kg
Min. voltage required:	90% of nominal
Coil type:	M7 type
Seal kit:	RD900013

NOTES

Installation torque: 135 - 150 Nm

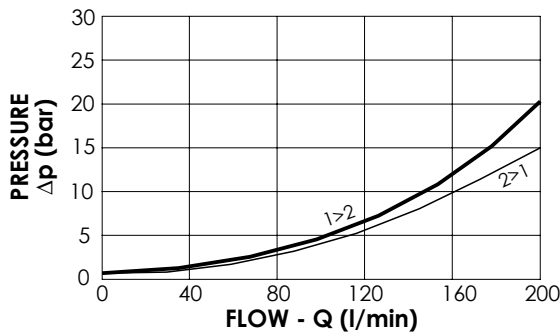

OPTIONS

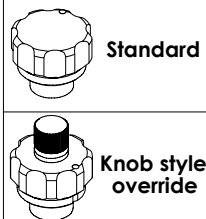

SEALING CAP

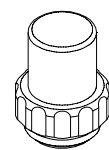

Ordering code:
AT000113

ORDERING CODES

Quick code	Description	Options	Max operating pressure (bar)
CE000366	CEBN-200-NCFN-31-013-N350	Standard	350
CE000368	CEBN-200-NCFK-31-013-N350	Knob style override	350
CE000666	CEBN-200-NCFN-31-013-N500	Standard	500
CE000668	CEBN-200-NCFK-31-013-N500	Knob style override	500

SOLENOID OPERATED CARTRIDGE

CEBN-300-NCFN

**PILOT OPERATED
POPPET TYPE**

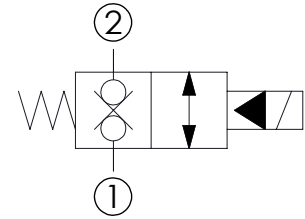
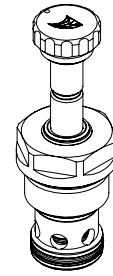
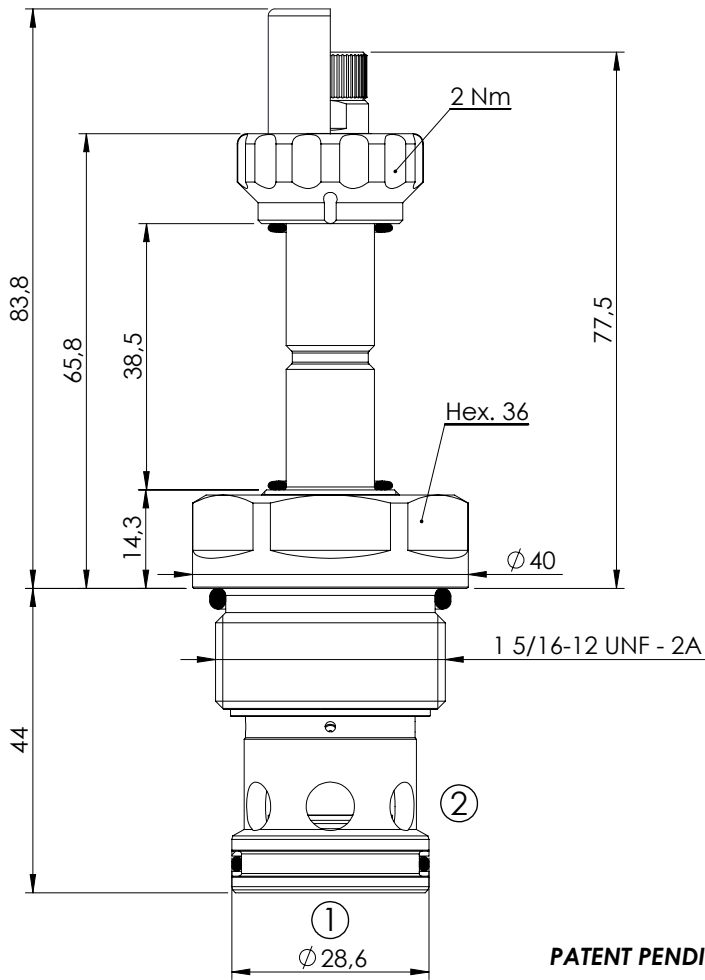

SPECIFICATIONS

Max. operating pressure:	350/500 bar
Rated flow:	300 l/min
Cavity:	SAE-16-2N
Weight:	0,36 kg
Min. voltage required:	90% of nominal
Coil type:	M7 type
Seal kit:	RB900084

NOTES

Installation torque: 118 - 132 Nm

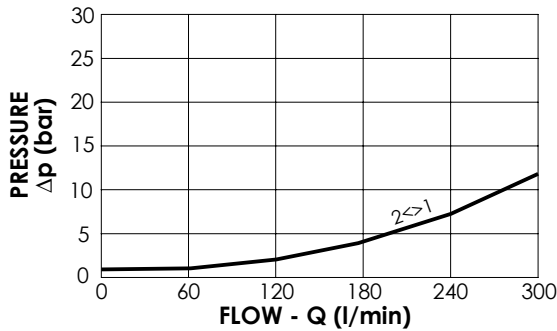

OPTIONS

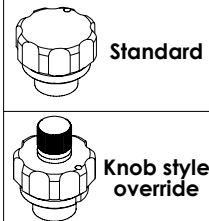

SEALING CAP

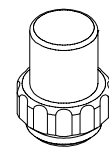

Ordering code:
AT000113

ORDERING CODES

Quick code	Description	Options	Max operating pressure (bar)
CE000401	CEBN-300-NCFN-31-S16-N350	Standard	350
CE000403	CEBN-300-NCFK-31-S16-N350	Knob style override	350
CE000701	CEBN-300-NCFN-31-S16-N500	Standard	500
CE000703	CEBN-300-NCFK-31-S16-N500	Knob style override	500

SOLENOID OPERATED CARTRIDGE

CEBN-040-NAFN

**PILOT OPERATED
POPPET TYPE**

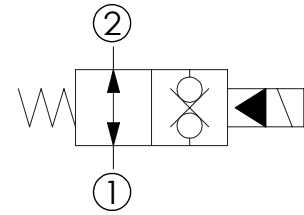
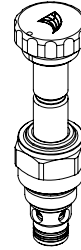
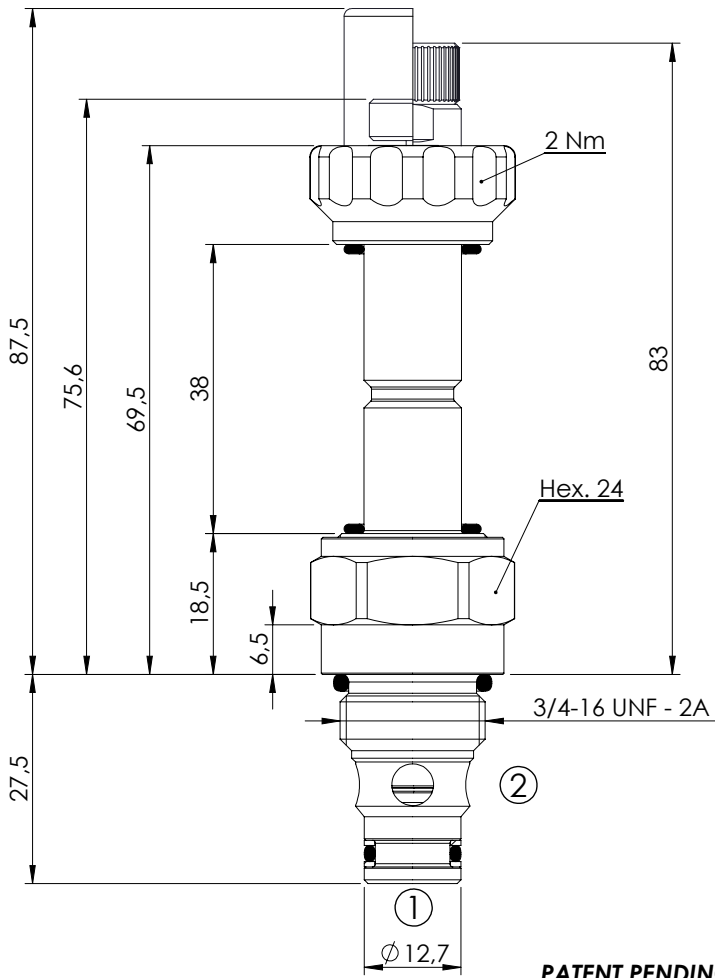

SPECIFICATIONS

Max. operating pressure:	350/500 bar
Rated flow:	40 l/min
Cavity:	SAE-08-2N
Weight:	0,14 kg
Min. voltage required:	90% of nominal
Coil type:	M7 type
Seal kit:	RB900081

NOTES

Installation torque: 45 - 50 Nm

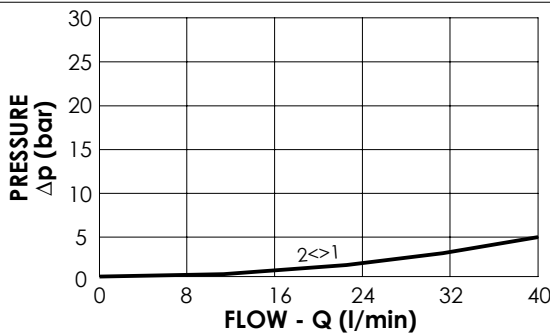

OPTIONS

- Standard
- Push style override
- Knob style override

SEALING CAP

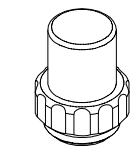

Ordering code:
AT000113

ORDERING CODES

Quick code	Description	Options	Max operating pressure (bar)
CE000242	CEBN-040-NAFN-32-S08-N350	Standard	350
CE000243	CEBN-040-NAFP-32-S08-N350	Push style override	350
CE000244	CEBN-040-NAFK-32-S08-N350	Knob style override	350
CE000542	CEBN-040-NAFN-32-S08-N500	Standard	500
CE000543	CEBN-040-NAFP-32-S08-N500	Push style override	500
CE000544	CEBN-040-NAFK-32-S08-N500	Knob style override	500

SOLENOID OPERATED CARTRIDGE

CEBN-070-NAFN

**PILOT OPERATED
POPPET TYPE**

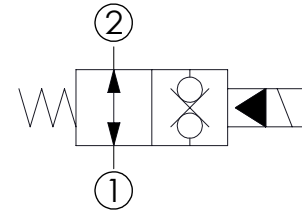
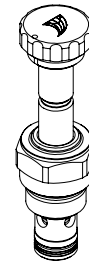
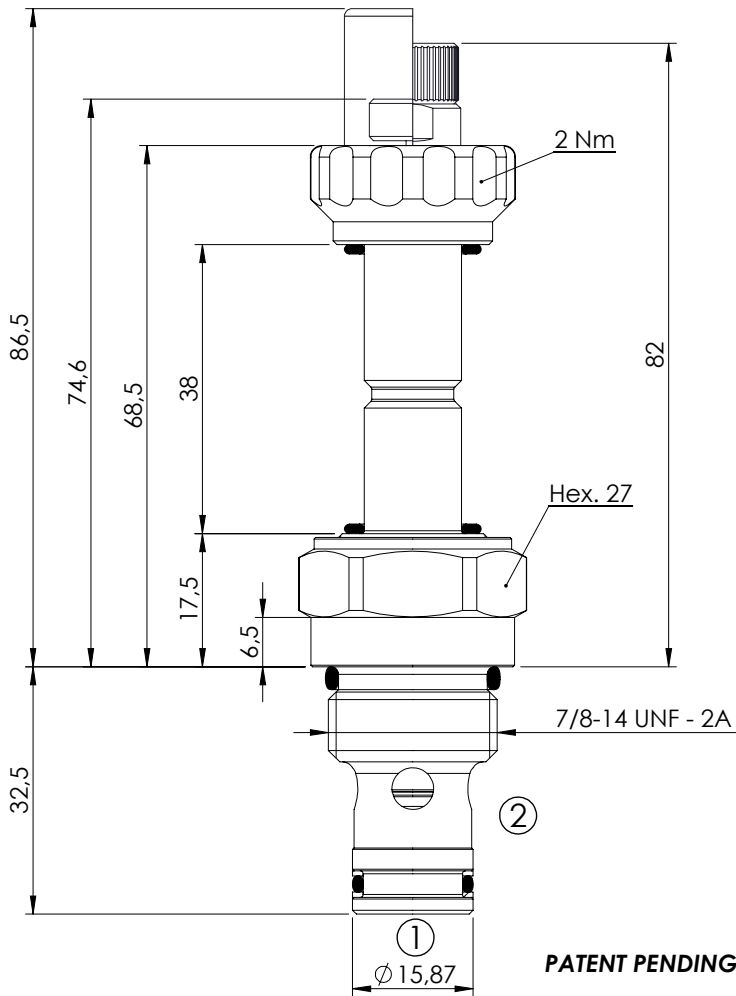

SPECIFICATIONS

Max. operating pressure:	350/500 bar
Rated flow:	70 l/min
Cavity:	SAE-10-2N
Weight:	0,18 kg
Min. voltage required:	90% of nominal
Coil type:	M7 type
Seal kit:	RB900082

NOTES

Installation torque: 55 - 62 Nm

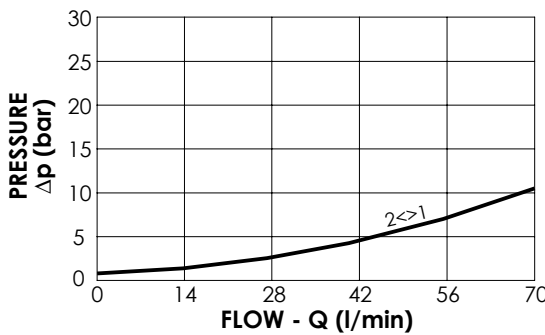

OPTIONS

- Standard
- Push style override
- Knob style override

SEALING CAP

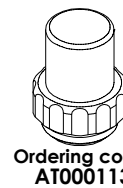

ORDERING CODES

Quick code	Description	Options	Max operating pressure (bar)
CE000277	CEBN-070-NAFN-32-S10-N350	Standard	350
CE000278	CEBN-070-NAFP-32-S10-N350	Push style override	350
CE000279	CEBN-070-NAFK-32-S10-N350	Knob style override	350
CE000577	CEBN-070-NAFN-32-S10-N500	Standard	500
CE000578	CEBN-070-NAFP-32-S10-N500	Push style override	500
CE000579	CEBN-070-NAFK-32-S10-N500	Knob style override	500

SOLENOID OPERATED CARTRIDGE

CEBN-100-NAFN

**PILOT OPERATED
POPPET TYPE**

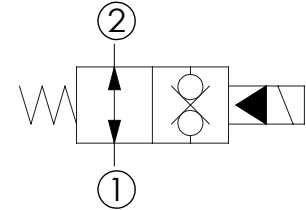
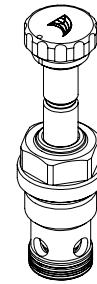
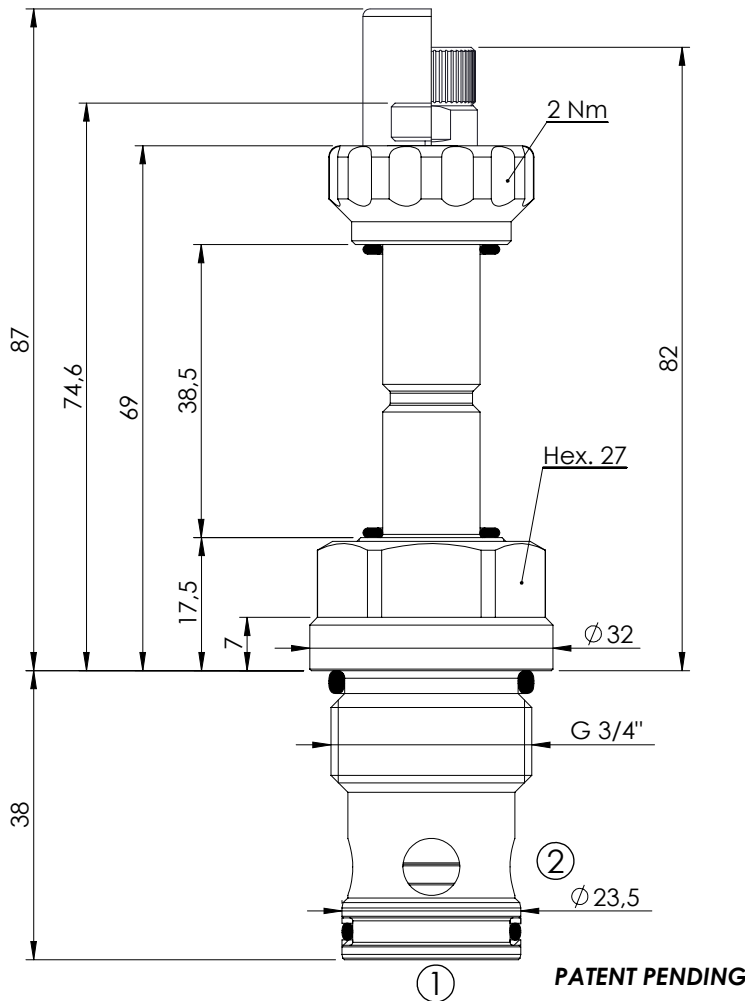

SPECIFICATIONS

Max. operating pressure:	350/500 bar
Rated flow:	100 l/min
Cavity:	VP000057
Weight:	0,25 kg
Min. voltage required:	90% of nominal
Coil type:	M7 type
Seal kit:	RD900057

NOTES

Installation torque: 110 - 130 Nm

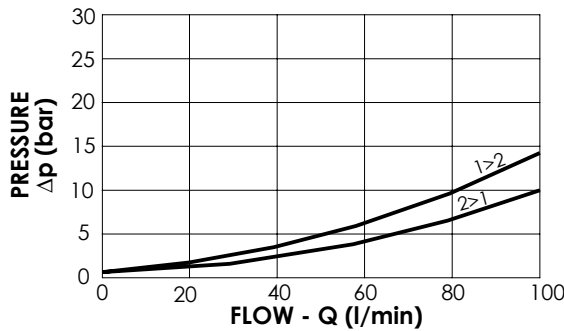

OPTIONS

- Standard
- Push style override
- Knob style override

SEALING CAP

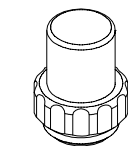

Ordering code:
AT000113

ORDERING CODES

Quick code	Description	Options	Max operating pressure (bar)
CE000312	CEBN-100-NAFN-32-057-N350	Standard	350
CE000313	CEBN-100-NAFP-32-057-N350	Push style override	350
CE000314	CEBN-100-NAFK-32-057-N350	Knob style override	350
CE000612	CEBN-100-NAFN-32-057-N500	Standard	500
CE000613	CEBN-100-NAFP-32-057-N500	Push style override	500
CE000614	CEBN-100-NAFK-32-057-N500	Knob style override	500

SOLENOID OPERATED CARTRIDGE

CEBN-180-NAFN

**PILOT OPERATED
POPPET TYPE**

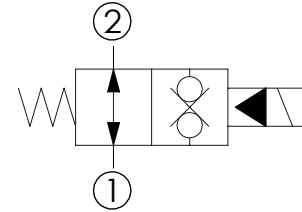
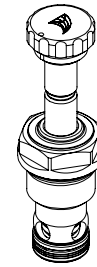
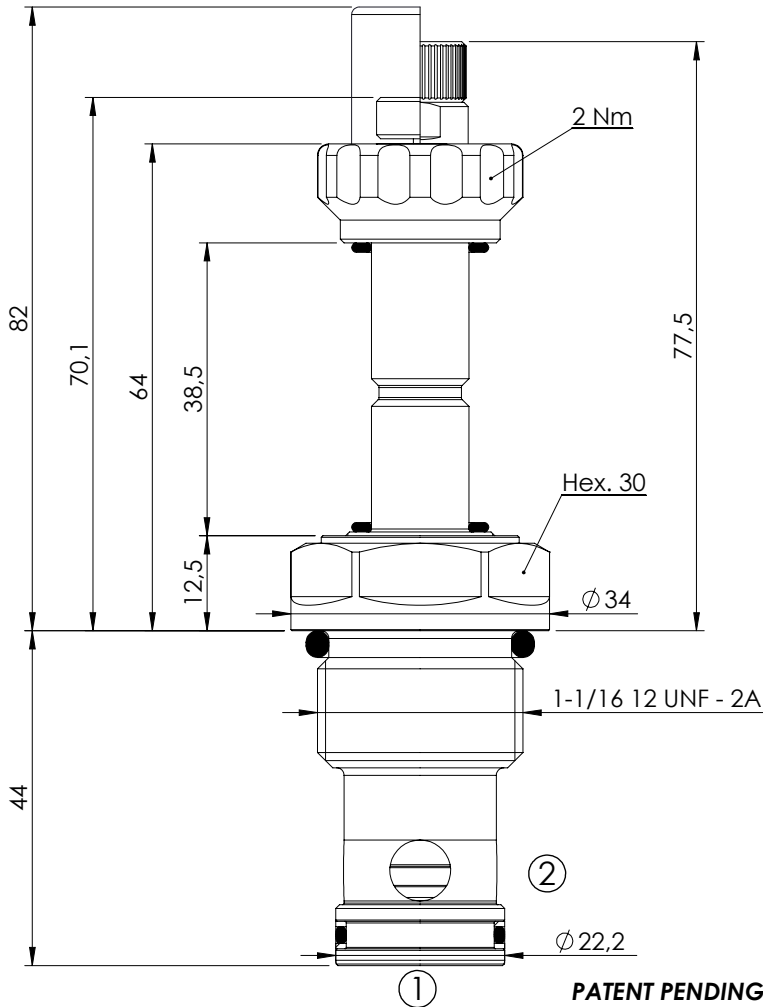

SPECIFICATIONS

Max. operating pressure:	350/500 bar
Rated flow:	180 l/min
Cavity:	SAE-12-2N
Weight:	0,25 kg
Min. voltage required:	90% of nominal
Coil type:	M7 type
Seal kit:	RB900083

NOTES

Installation torque: 135 - 150 Nm

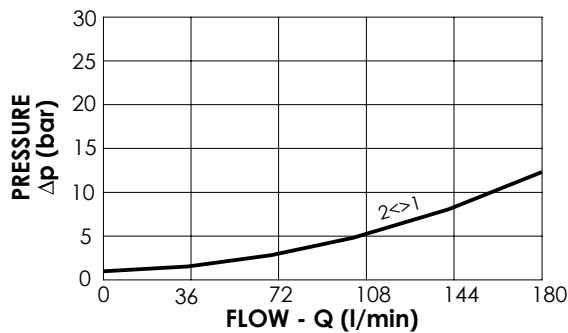

OPTIONS

- Standard
- Push style override
- Knob style override

SEALING CAP

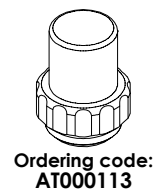

ORDERING CODES

Quick code	Description	Options	Max operating pressure (bar)
CE000347	CEBN-180-NAFN-32-S12-N350	Standard	350
CE000348	CEBN-180-NAFP-32-S12-N350	Push style override	350
CE000349	CEBN-180-NAFK-32-S12-N350	Knob style override	350
CE000647	CEBN-180-NAFN-32-S12-N500	Standard	500
CE000648	CEBN-180-NAFP-32-S12-N500	Push style override	500
CE000649	CEBN-180-NAFK-32-S12-N500	Knob style override	500

SOLENOID OPERATED CARTRIDGE

CEBN-200-NAFN

**PILOT OPERATED
POPPET TYPE**

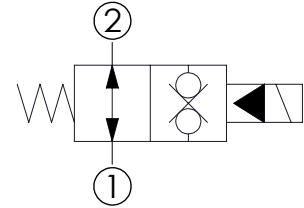
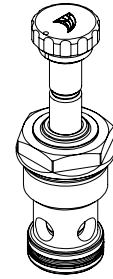
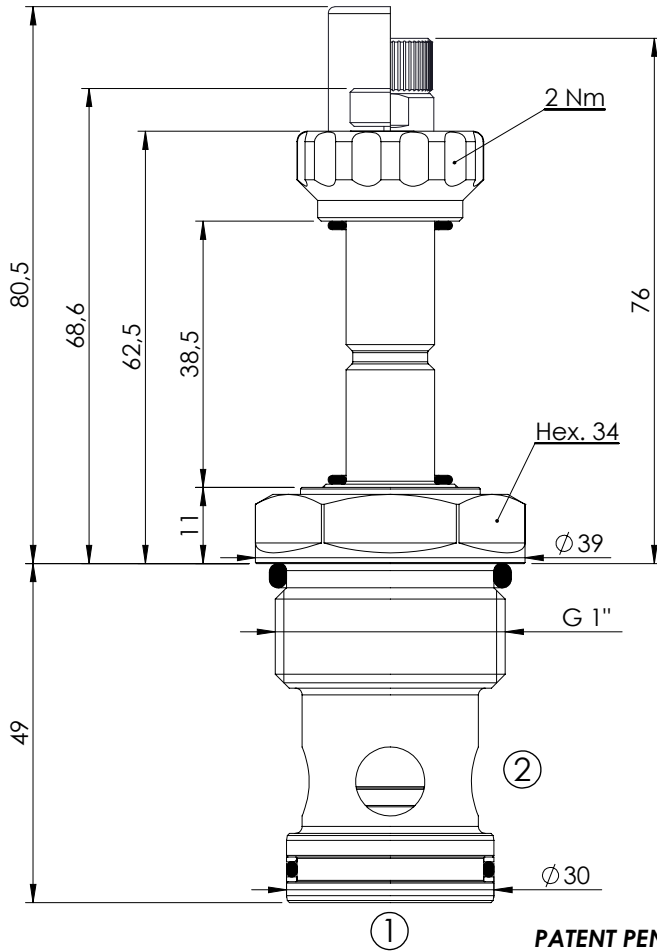

SPECIFICATIONS

Max. operating pressure:	350/500 bar
Rated flow:	200 l/min
Cavity:	VP000013
Weight:	0,35 kg
Min. voltage required:	90% of nominal
Coil type:	M7 type
Seal kit:	RD900013

NOTES

Installation torque: 135 - 150 Nm

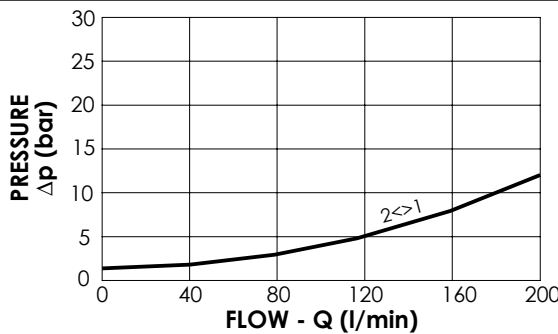

OPTIONS

- Standard
- Push style override
- Knob style override

SEALING CAP

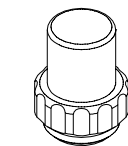

Ordering code:
AT000113

ORDERING CODES

Quick code	Description	Options	Max operating pressure (bar)
CE000382	CEBN-200-NAFN-32-013-N350	Standard	350
CE000383	CEBN-200-NAFP-32-013-N350	Push style override	350
CE000384	CEBN-200-NAFK-32-013-N350	Knob style override	350
CE000682	CEBN-200-NAFN-32-013-N500	Standard	500
CE000683	CEBN-200-NAFP-32-013-N500	Push style override	500
CE000684	CEBN-200-NAFK-32-013-N500	Knob style override	500

SOLENOID OPERATED CARTRIDGE

CEBN-300-NAFN

**PILOT OPERATED
POPPET TYPE**

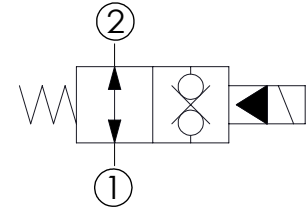
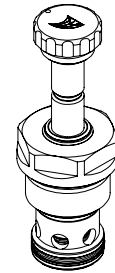
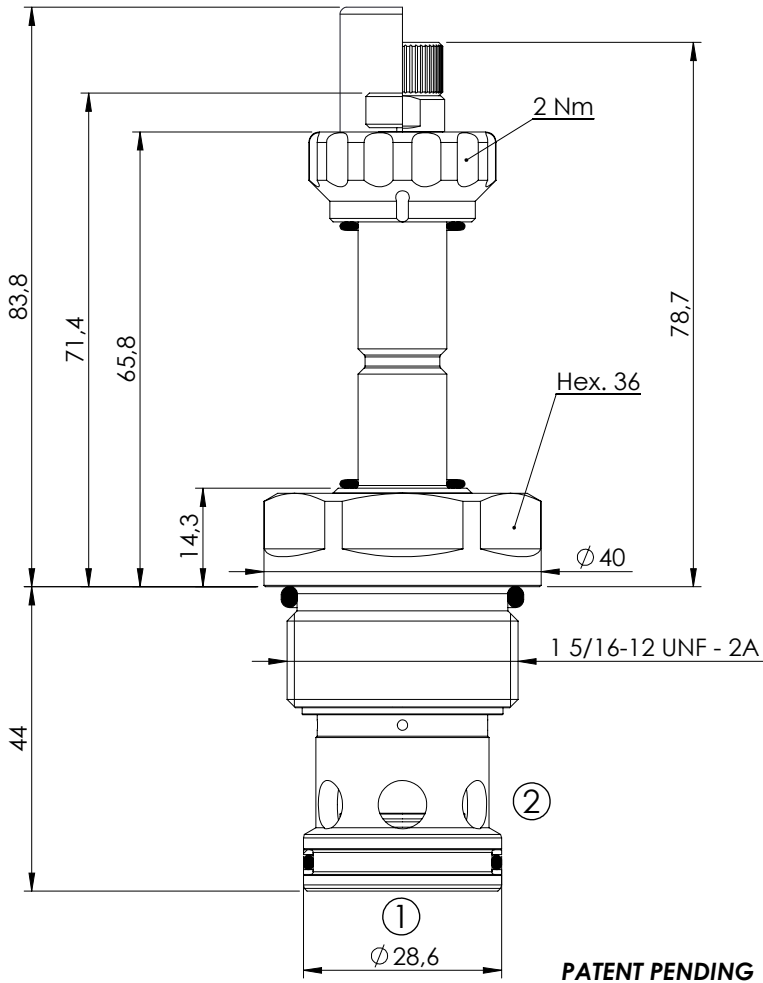

SPECIFICATIONS



Max. operating pressure:	350/500 bar
Rated flow:	300 l/min
Cavity:	SAE-16-2N
Weight:	0,36 kg
Min. voltage required:	90% of nominal
Coil type:	M7 type
Seal kit:	RB900084

NOTES

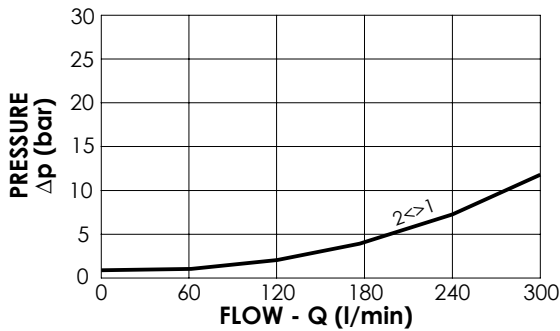
Installation torque: 118 - 132 Nm



OPTIONS

-  Standard
-  Push style override
-  Knob style override

SEALING CAP

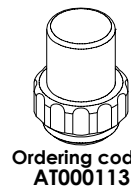

ORDERING CODES

Quick code	Description	Options	Max operating pressure (bar)
CE000417	CEBN-300-NAFN-32-S16-N350	Standard	350
CE000418	CEBN-300-NAFP-32-S16-N350	Push style override	350
CE000419	CEBN-300-NAFK-32-S16-N350	Knob style override	350
CE000717	CEBN-300-NAFN-32-S16-N500	Standard	500
CE000718	CEBN-300-NAFP-32-S16-N500	Push style override	500
CE000719	CEBN-300-NAFK-32-S16-N500	Knob style override	500

SOLENOID OPERATED CARTRIDGE

CEBN-040-NCDR

**POPPET TYPE
PROXIMITY SENSOR**

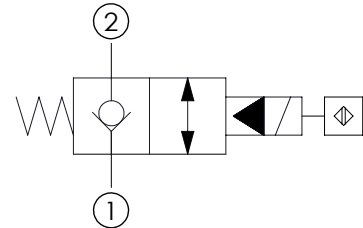
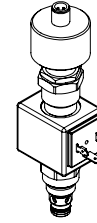
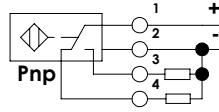
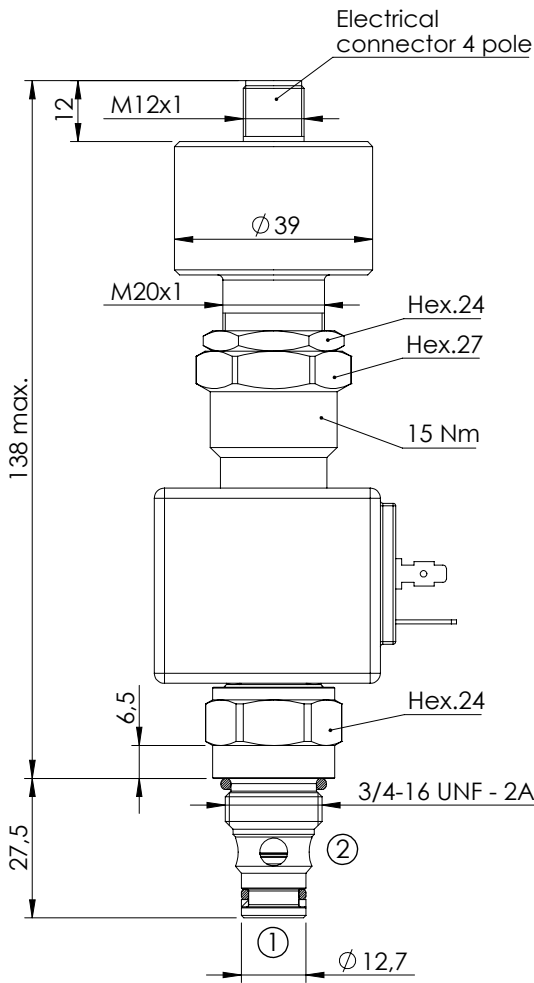

SPECIFICATIONS

Max. operating pressure:	350 bar
Rated flow:	40 l/min
Cavity:	SAE-08-2N
Weight:	0,5 kg
Coil type:	M7 type
Operating temperature:	-25/+80°C

NOTES

Installation torque:	45 - 50 Nm
Seal kit:	RA100081

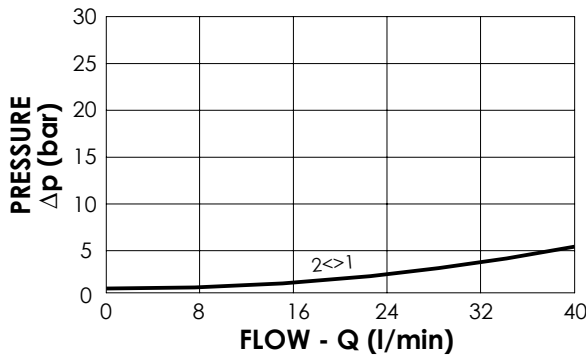

ORDERING CODES

Quick code	Description	Connector	Voltage	Options
CE000472	CEBN-040-NCDR-100-S08-V350-12HR	DIN 43650	12V DC	Proximity sensor
CE000940	CEBN-040-NCDR-100-S08-V350-24HR	DIN 43650	24V DC	Proximity sensor

SOLENOID OPERATED CARTRIDGE

CEBN-070-NCDR

**POPPET TYPE
PROXIMITY SENSOR**

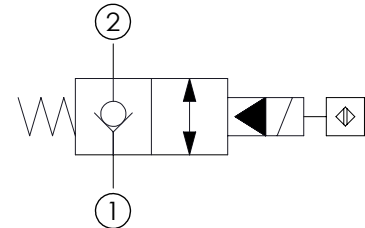
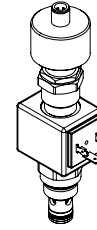
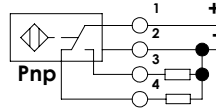
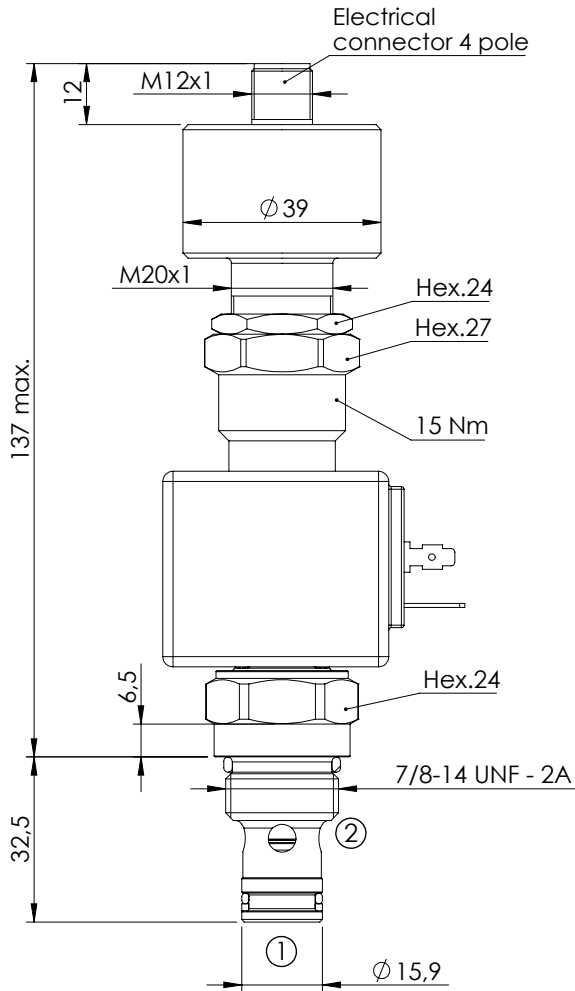

SPECIFICATIONS

Max. operating pressure:	350 bar
Rated flow:	70 l/min
Cavity:	SAE-10-2N
Weight:	0,5 kg
Coil type:	M7 type
Operating temperature:	-25/+80°C

NOTES

Installation torque:	55 - 62 Nm
Seal kit:	RA100082

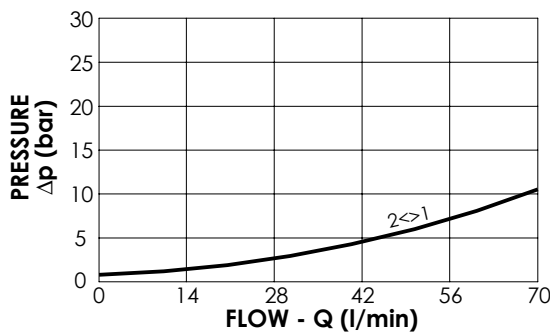

ORDERING CODES

Quick code	Description	Connector	Voltage	Options
CE000473	CEBN-070-NCDR-100-S10-V350-12HR	DIN 43650	12V DC	Proximity sensor
CE000938	CEBN-070-NCDR-100-S10-V350-24HR	DIN 43650	24V DC	Proximity sensor

SOLENOID OPERATED CARTRIDGE

CEBN-100-NCDR

**POPPET TYPE
PROXIMITY SENSOR**

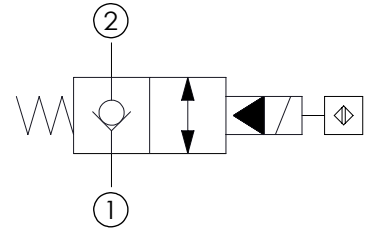
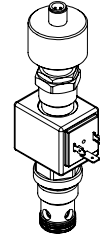
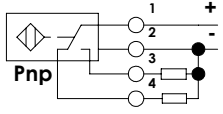
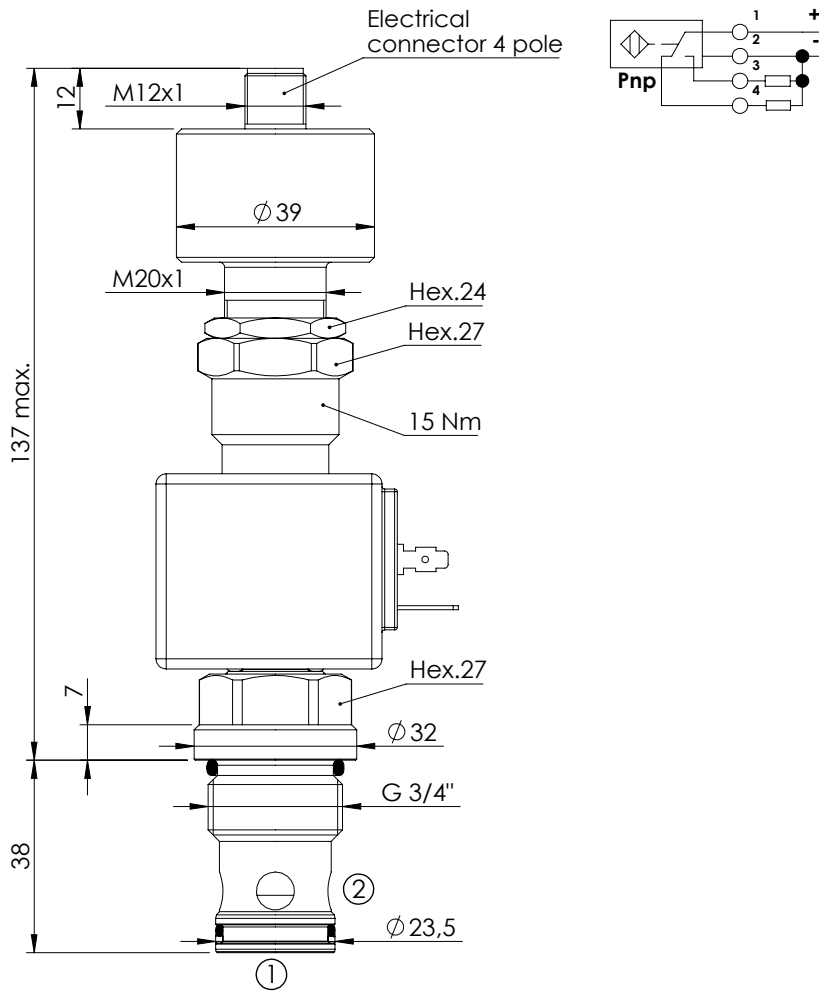

SPECIFICATIONS

Max. operating pressure:	350 bar
Rated flow:	100 l/min
Cavity:	VP000057
Weight:	0,6 kg
Coil type:	M7 type
Operating temperature:	-25/+80°C

NOTES

Installation torque:	110 - 130 Nm
Seal kit:	RC100057

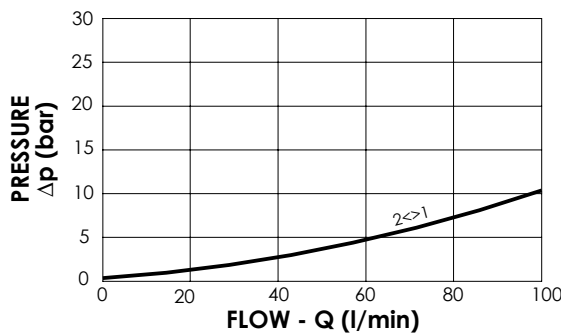

ORDERING CODES

Quick code	Description	Connector	Voltage	Options
CE001088	CEBN-100-NCDR-100-057-V350-12HR	DIN 43650	12V DC	Proximity sensor
CE001089	CEBN-100-NCDR-100-057-V350-24HR	DIN 43650	24V DC	Proximity sensor

SOLENOID OPERATED CARTRIDGE

CEBN-300-NCDR

**POPPET TYPE
PROXIMITY SENSOR**

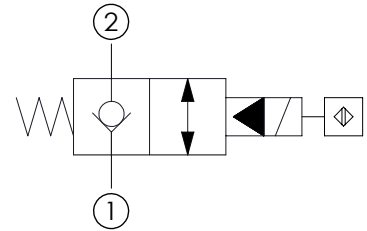
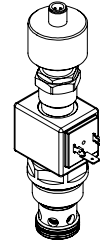
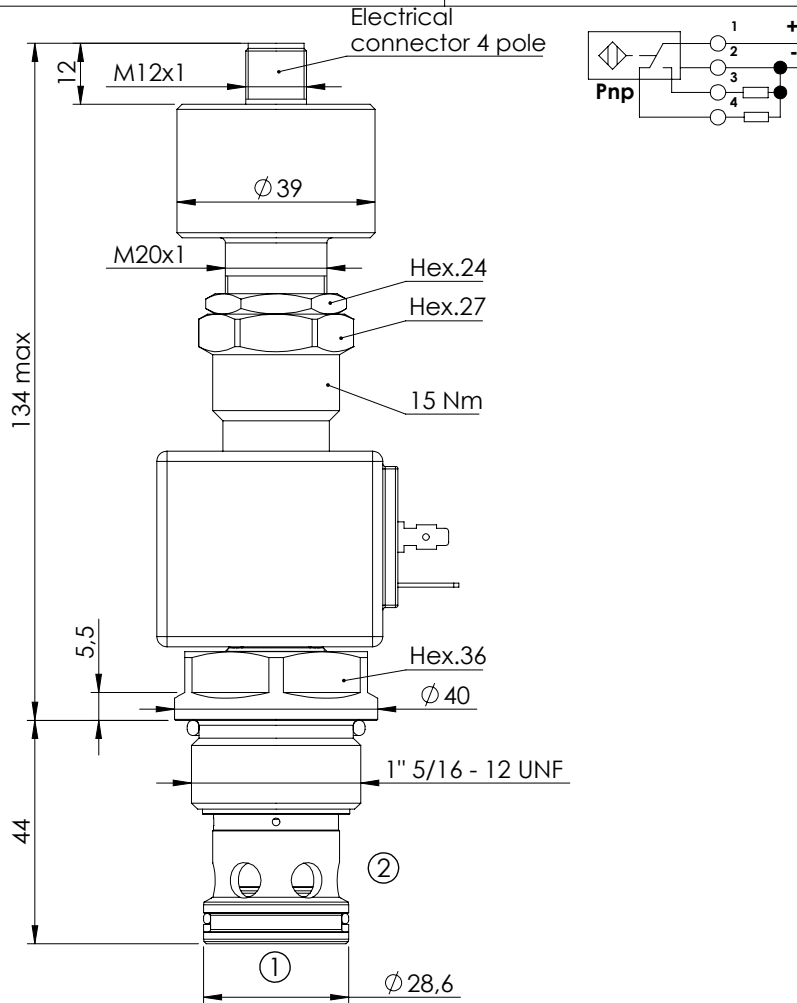

SPECIFICATIONS

Max. operating pressure:	350 bar
Rated flow:	300 l/min
Cavity:	SAE-16-2N
Weight:	0,7 kg
Coil type:	M7 type
Operating temperature:	-25/+80 °C

NOTES

Installation torque:	118 - 132 Nm
Seal kit:	RA100084

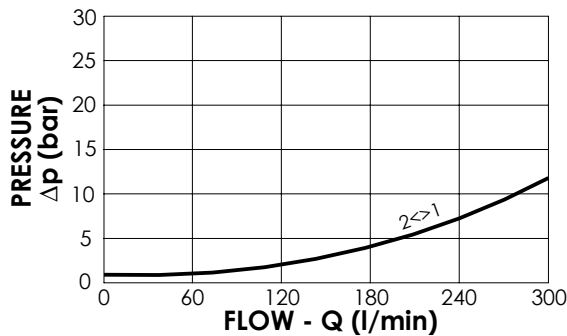

ORDERING CODES

Quick code	Description	Connector	Voltage	Options
CE000475	CEBN-300-NCDR-100-S16-V350-12HR	DIN 43650	12V DC	Proximity sensor
CE000939	CEBN-300-NCDR-100-S16-V350-24HR	DIN 43650	24V DC	Proximity sensor

SOLENOID OPERATED CARTRIDGE

CEBN-040-NADR

**POPPET TYPE
PROXIMITY SENSOR**

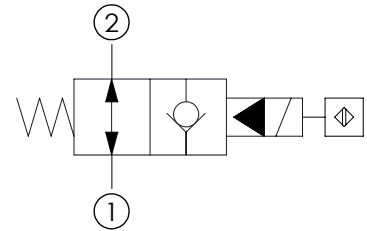
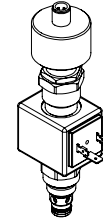
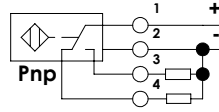
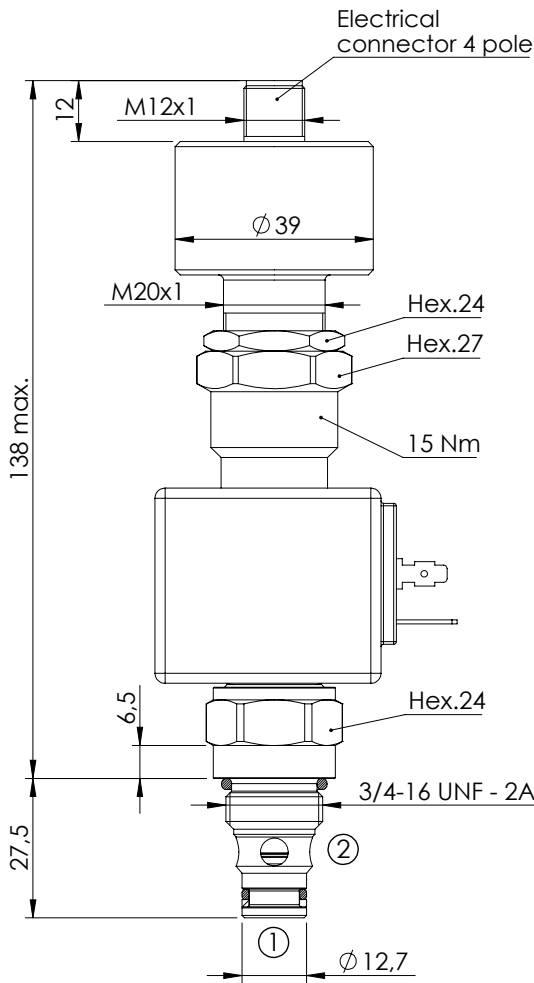

SPECIFICATIONS

Max. operating pressure:	350 bar
Rated flow:	40 l/min
Cavity:	SAE-08-2N
Weight:	0,5 kg
Coil type:	M7 type
Operating temperature:	-25/+80°C

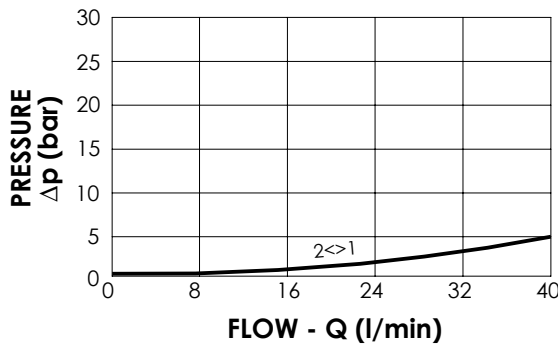

NOTES

Installation torque:	45 - 50 Nm
Seal kit:	RA100081

ORDERING CODES

Quick code	Description	Connector	Voltage	Options
CE001053	CEBN-040-NADR-101-S08-V350-12HR	DIN 43650	12V DC	Proximity sensor
CE000476	CEBN-040-NADR-101-S08-V350-24HR	DIN 43650	24V DC	Proximity sensor

SOLENOID OPERATED CARTRIDGE

CEBN-070-NADR

**POPET TYPE
PROXIMITY SENSOR**

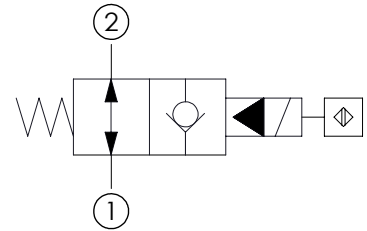
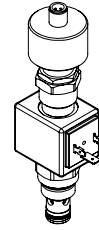
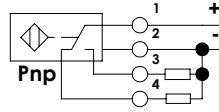
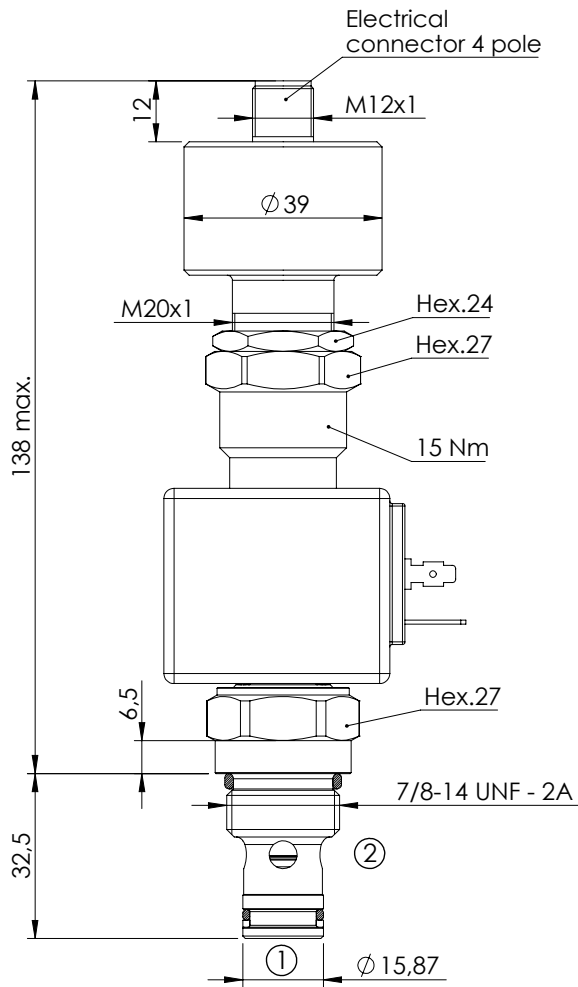

SPECIFICATIONS

Max. operating pressure:	350 bar
Rated flow:	70 l/min
Cavity:	SAE-10-2N
Weight:	0,5 kg
Coil type:	M7 type
Operating temperature:	-25/+80°C

NOTES

Installation torque:	55 - 62 Nm
Seal kit:	RA100082

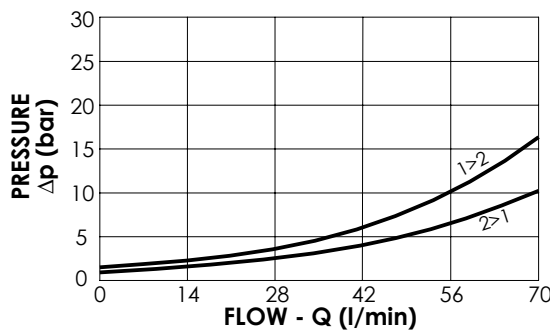

ORDERING CODES

Quick code	Description	Connector	Voltage	Options
CE001043	CEBN-070-NADR-101-S10-V350-12HR	DIN 43650	12V DC	Proximity sensor
CE001065	CEBN-070-NADR-101-S10-V350-24HR	DIN 43650	24V DC	Proximity sensor

SOLENOID OPERATED CARTRIDGE

CEBN-100-NAFN

**POPPET TYPE
PROXIMITY SENSOR**

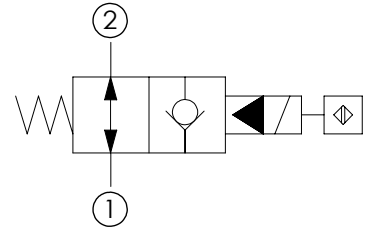
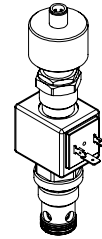
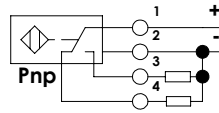
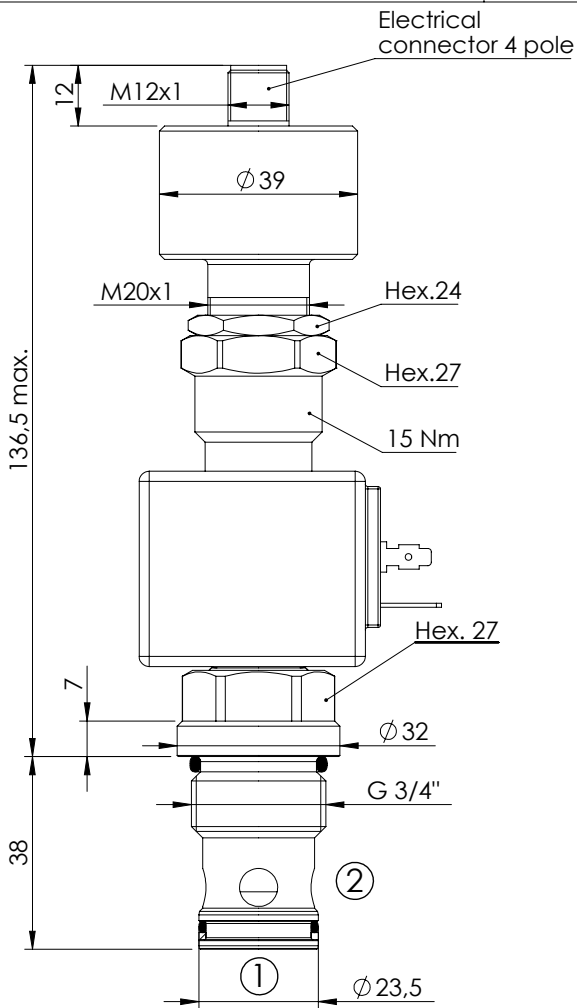

SPECIFICATIONS

Max. operating pressure:	350 bar
Rated flow:	100 l/min
Cavity:	VP000057
Weight:	0,6 kg
Coil type:	M7 type
Operating temperature:	-25/+80°C

NOTES

Installation torque:	110 - 130 Nm
Seal kit:	RC100057

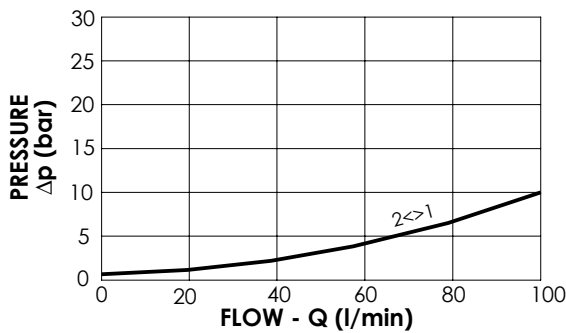

ORDERING CODES

Quick code	Description	Connector	Voltage	Options
CE001094	CEBN-100-NAFN-101-057-V350-12HR	DIN 43650	12V DC	Proximity sensor
CE001095	CEBN-100-NAFN-101-057-V350-24HR	DIN 43650	24V DC	Proximity sensor

SOLENOID OPERATED CARTRIDGE

CEBN-180-NAFN

**POPPET TYPE
PROXIMITY SENSOR**

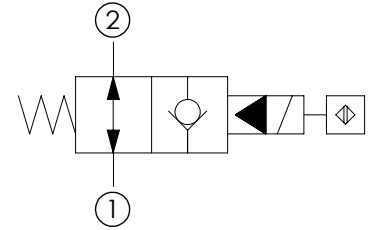
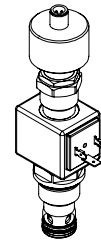
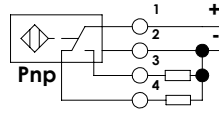
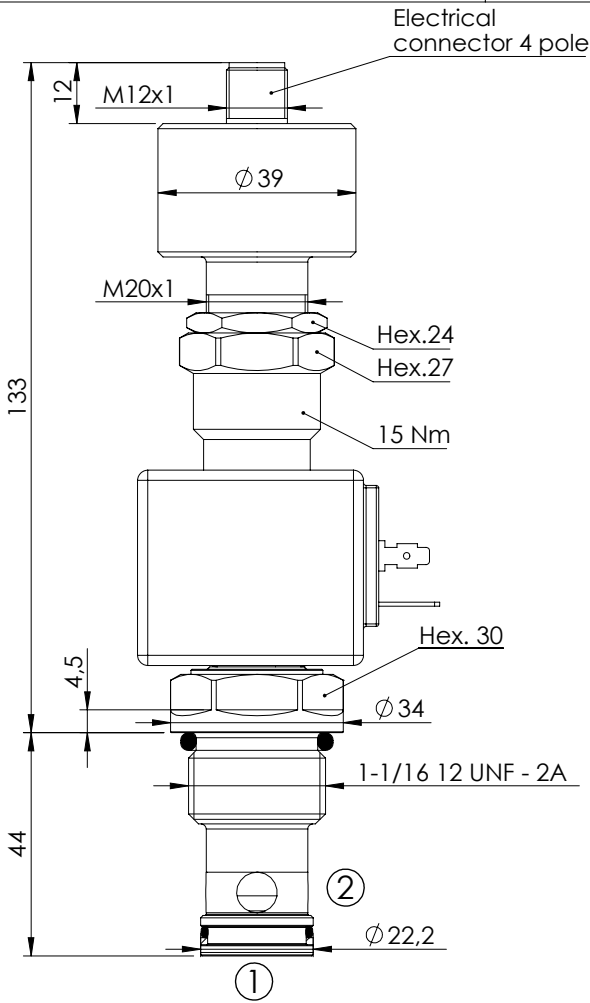

SPECIFICATIONS

Max. operating pressure:	350 bar
Rated flow:	180 l/min
Cavity:	SAE-12-2N
Weight:	0,6 kg
Coil type:	M7 type
Operating temperature:	-25/+80°C

NOTES

Installation torque:	135 - 150 Nm
Seal kit:	RA100083

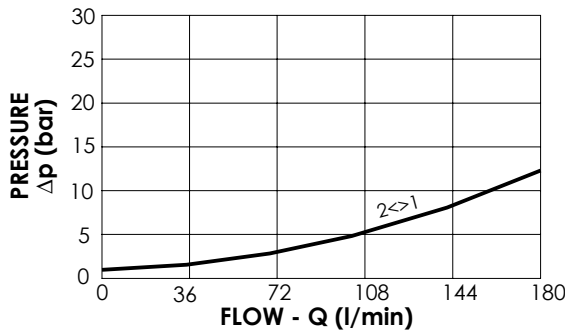

ORDERING CODES

Quick code	Description	Connector	Voltage	Options
CE001096	CEBN-180-NAFN-101-S12-V350-12HR	DIN 43650	12V DC	Proximity sensor
CE001097	CEBN-180-NAFN-101-S12-V350-24HR	DIN 43650	24V DC	Proximity sensor

SOLENOID OPERATED CARTRIDGE

CEBN-200-NAFN

**POPPET TYPE
PROXIMITY SENSOR**

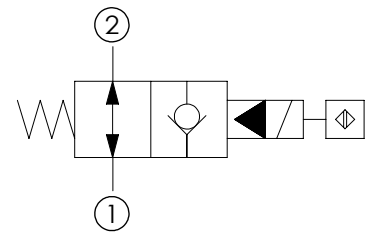
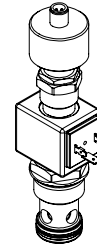
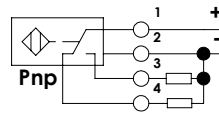
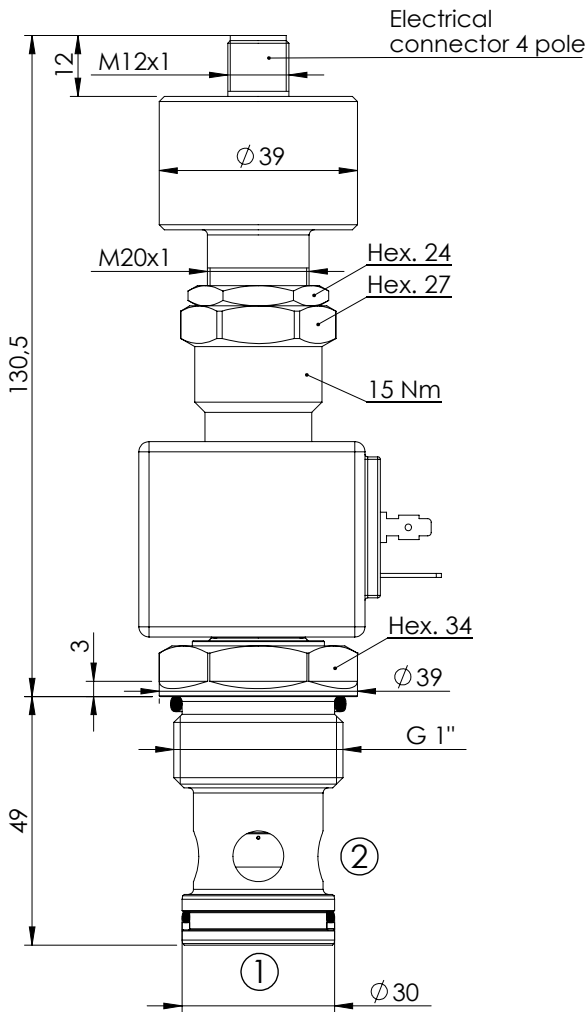

SPECIFICATIONS

Max. operating pressure:	350 bar
Rated flow:	200 l/min
Cavity:	VP000013
Weight:	0,71 kg
Coil type:	M7 type
Operating temperature:	-25/+80°C

NOTES

Installation torque:	135 - 150 Nm
Seal kit:	RC100013

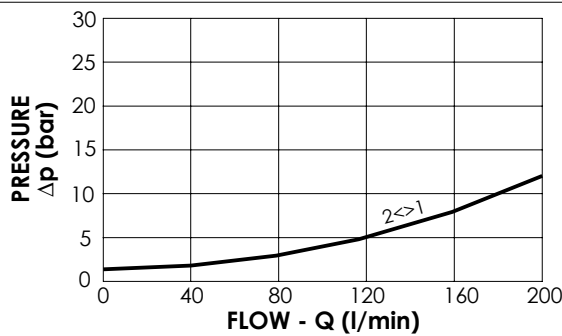

ORDERING CODES

Quick code	Description	Connector	Voltage	Options
CE001098	CEBN-200-NAFN-101-013-V350-12HR	DIN 43650	12V DC	Proximity sensor
CE001099	CEBN-200-NAFN-101-013-V350-24HR	DIN 43650	24V DC	Proximity sensor

SOLENOID OPERATED CARTRIDGE

CEBN-300-NADR

**POPPET TYPE
PROXIMITY SENSOR**

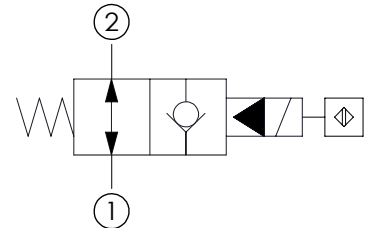
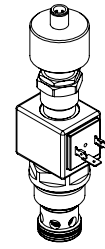
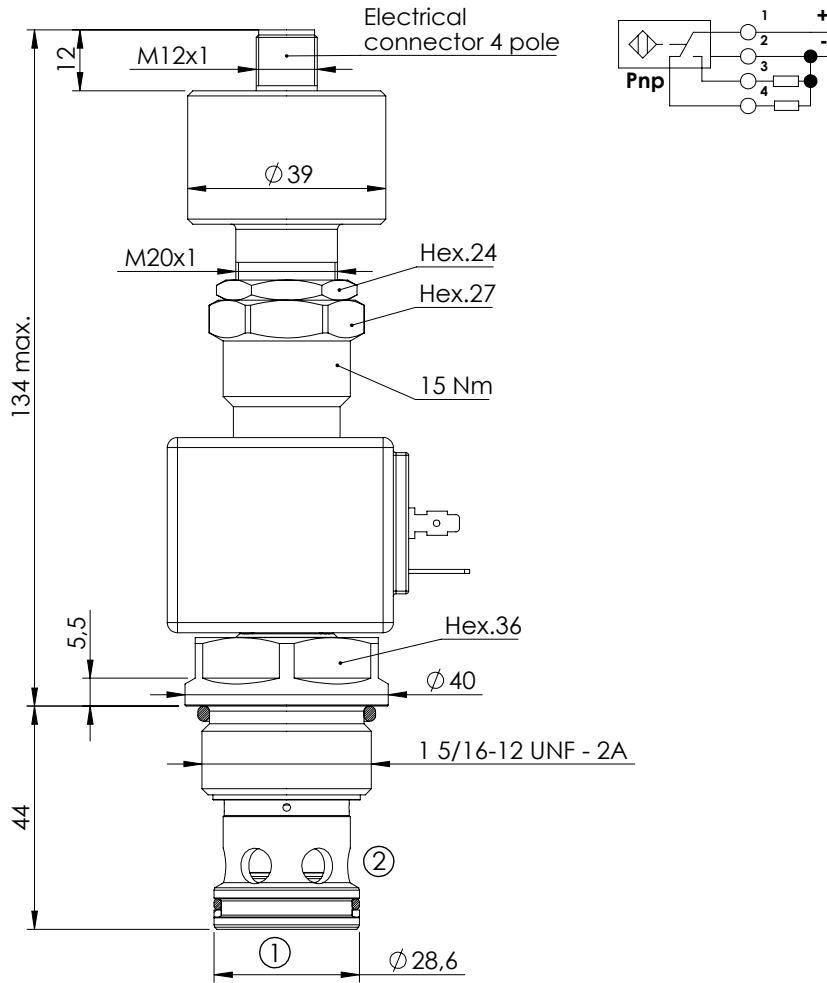

SPECIFICATIONS

Max. operating pressure:	350 bar
Rated flow:	300 l/min
Cavity:	SAE-16-2N
Weight:	0,7 kg
Coil type:	M7 type
Operating temperature:	-25/+80°C

NOTES

Installation torque:	118 - 132 Nm
Seal kit:	RA100084

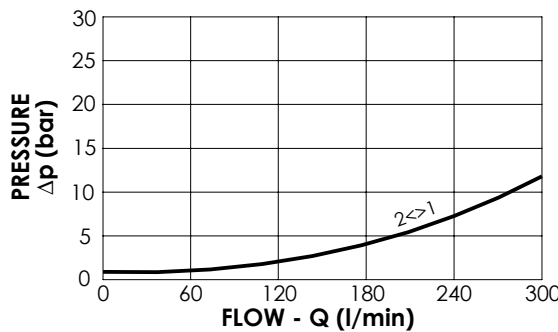

ORDERING CODES

Quick code	Description	Connector	Voltage	Options
CE001044	CEBN-300-NADR-101-S16-V350-12HR	DIN 43650	12V DC	Proximity sensor
CE001066	CEBN-300-NADR-101-S16-V350-24HR	DIN 43650	24V DC	Proximity sensor

SOLENOID OPERATED CARTRIDGE

CEBN-040-NCDR

**POPPET TYPE
PROXIMITY SENSOR**

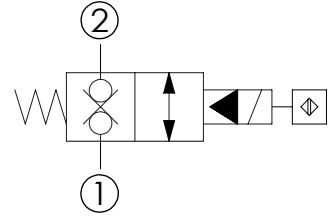
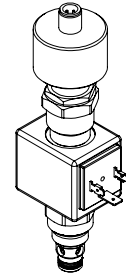
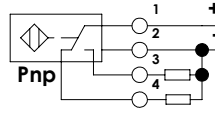
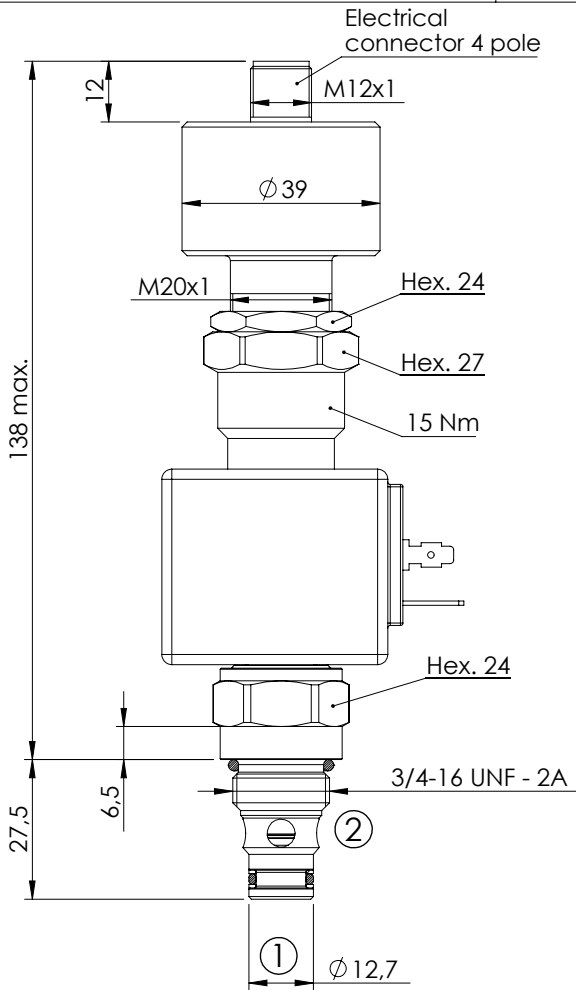

SPECIFICATIONS

Max. operating pressure:	350 bar
Rated flow:	40 l/min
Cavity:	SAE-08-2N
Weight:	0,5 kg
Coil type:	M7 type
Operating temperature:	-25/+80°C

NOTES

Installation torque:	45 - 50 Nm
Seal kit:	RB100081

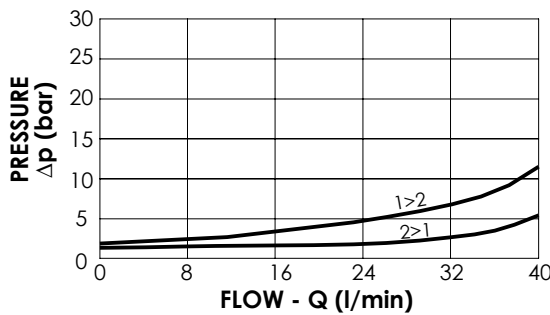

ORDERING CODES

Quick code	Description	Connector	Voltage	Options
CE001035	CEBN-040-NCDR-120-S08-V350-12HR	DIN 43650	12V DC	Proximity sensor
CE001064	CEBN-040-NCDR-120-S08-V350-24HR	DIN 43650	24V DC	Proximity sensor

SOLENOID OPERATED CARTRIDGE

CEBN-070-NCDR

**POPPET TYPE
PROXIMITY SENSOR**

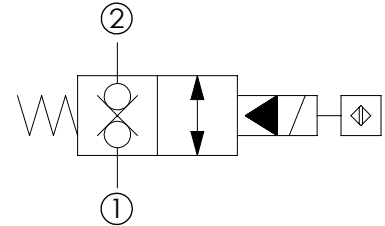
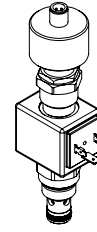
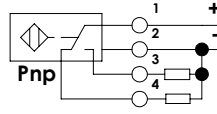
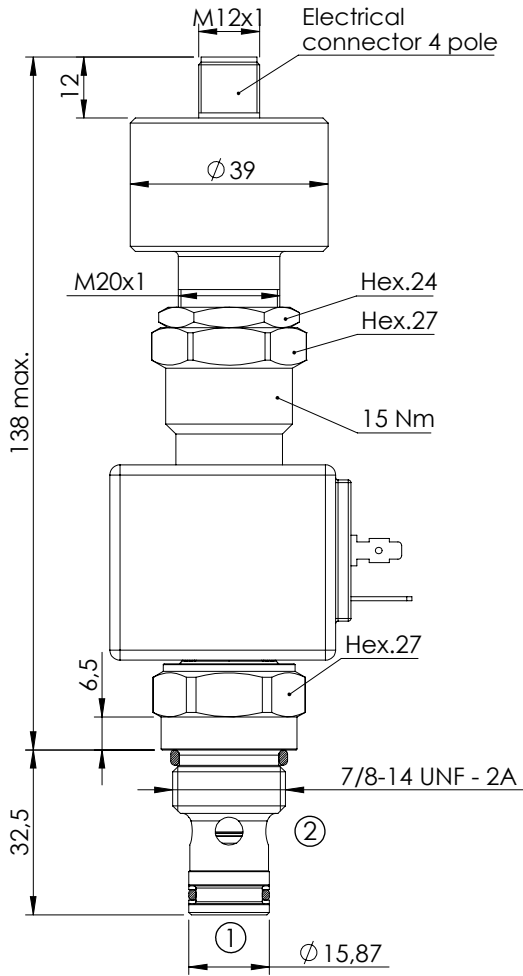

SPECIFICATIONS

Max. operating pressure:	350 bar
Rated flow:	70 l/min
Cavity:	SAE-10-2N
Weight:	0,53 kg
Coil type:	M7 type
Operating temperature:	-25/+80°C

NOTES

Installation torque:	55 - 62 Nm
Seal kit:	RB100082

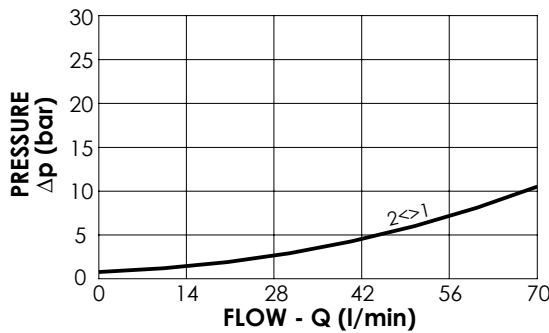

ORDERING CODES

Quick code	Description	Connector	Voltage	Options
CE001045	CEBN-070-NCDR-120-S10-V350-12HR	DIN 43650	12V DC	Proximity sensor
CE001067	CEBN-070-NCDR-120-S10-V350-24HR	DIN 43650	24V DC	Proximity sensor

SOLENOID OPERATED CARTRIDGE

CEBN-100-NCFN

**POPPET TYPE
PROXIMITY SENSOR**

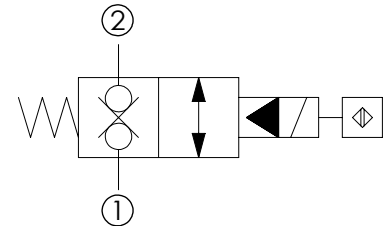
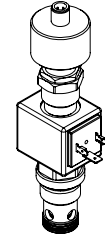
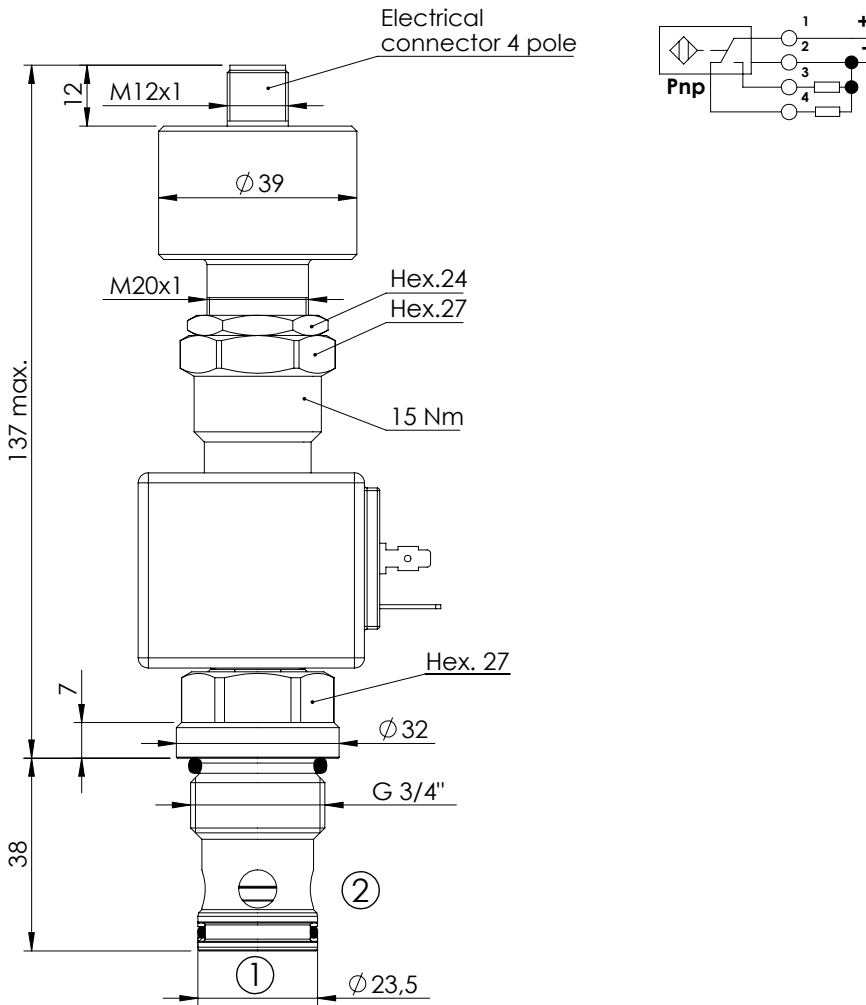

SPECIFICATIONS

Max. operating pressure:	350 bar
Rated flow:	100 l/min
Cavity:	VP000057
Weight:	0,6 kg
Coil type:	M7 type
Operating temperature:	-25/+80°C

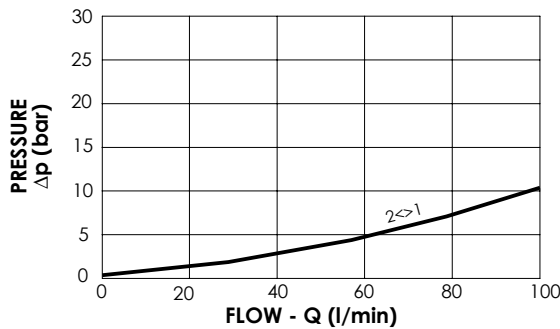

NOTES 110 - 130 Nm

Installation torque:	
Seal kit:	RD100057

ORDERING CODES

Quick code	Description	Connector	Voltage	Options
CE001100	CEBN-100-NCFN-120-057-V350-12HR	DIN 43650	12V DC	Proximity sensor
CE001101	CEBN-100-NCFN-120-057-V350-24HR	DIN 43650	24V DC	Proximity sensor

SOLENOID OPERATED CARTRIDGE



CEBN-180-NCFN

**POPPET TYPE
PROXIMITY SENSOR**

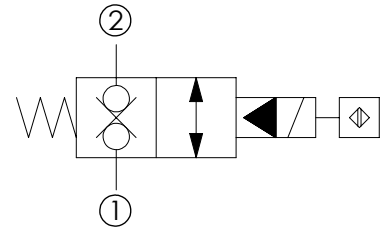
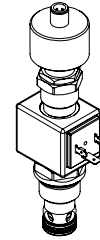
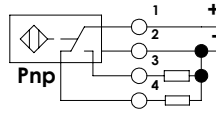
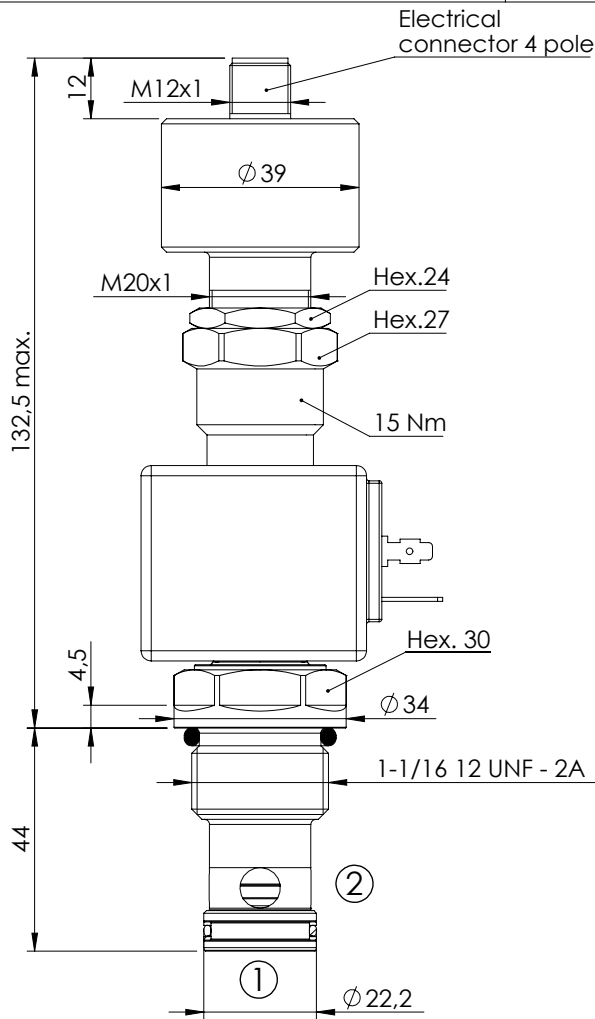

SPECIFICATIONS

Max. operating pressure:	350 bar
Rated flow:	180 l/min
Cavity:	SAE-12-2N
Weight:	0,6 kg
Coil type:	M7 type
Operating temperature:	-25/+80°C

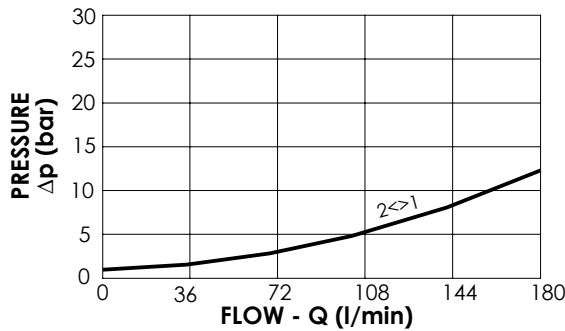

NOTES 135 - 150 Nm

Installation torque:	
Seal kit:	RB100083

ORDERING CODES

Quick code	Description	Connector	Voltage	Options
CE001102	CEBN-180-NCFN-120-S12-V350-12HR	DIN 43650	12V DC	Proximity sensor
CE001103	CEBN-180-NCFN-120-S12-V350-24HR	DIN 43650	24V DC	Proximity sensor

SOLENOID OPERATED CARTRIDGE

CEBN-200-NCFN

**POPPET TYPE
PROXIMITY SENSOR**

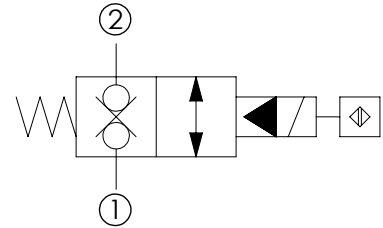
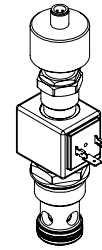
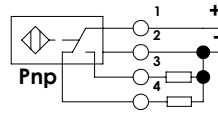
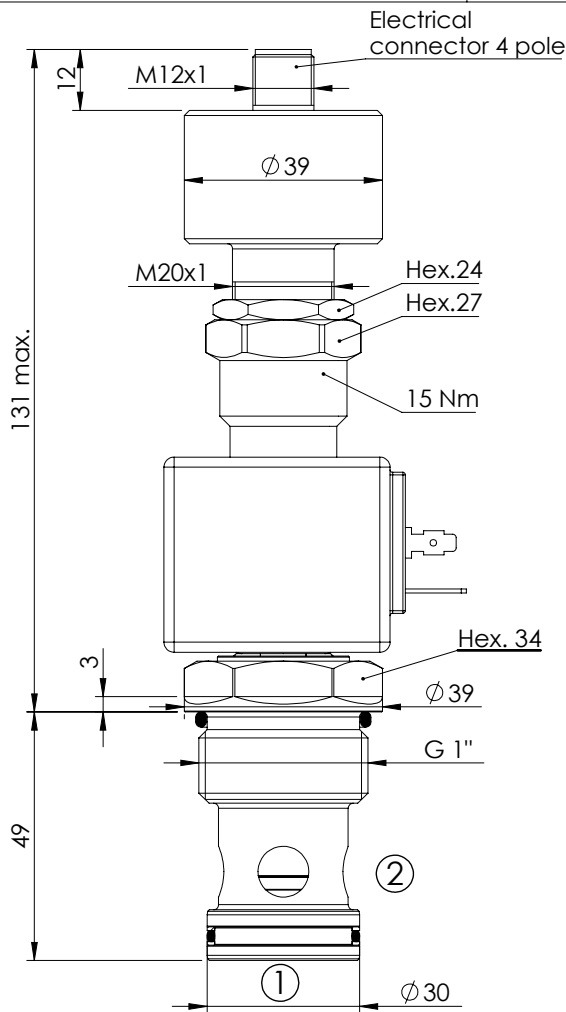

SPECIFICATIONS

Max. operating pressure:	350 bar
Rated flow:	200 l/min
Cavity:	VP000013
Weight:	0,7 kg
Coil type:	M7 type
Operating temperature:	-25/+80°C

NOTES

Installation torque:	135 - 150 Nm
Seal kit:	RD100013

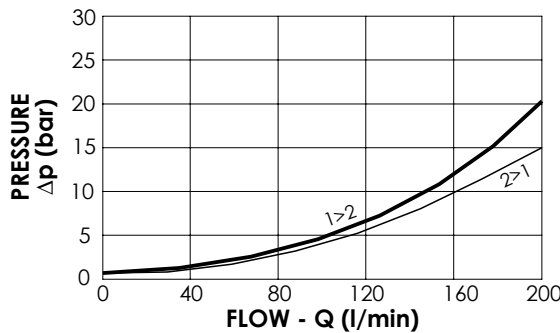

ORDERING CODES

Quick code	Description	Connector	Voltage	Options
CE001104	CEBN-200-NCFN-120-013-V350-12HR	DIN 43650	12V DC	Proximity sensor
CE001105	CEBN-200-NCFN-120-013-V350-24HR	DIN 43650	24V DC	Proximity sensor

SOLENOID OPERATED CARTRIDGE

CEBN-300-NCDR

**POPPET TYPE
PROXIMITY SENSOR**

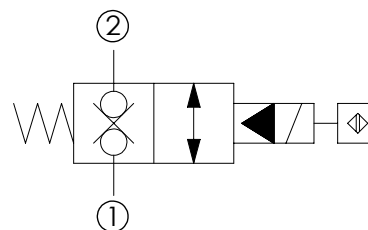
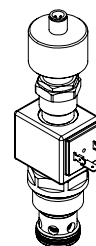
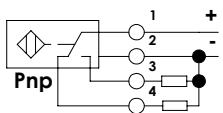
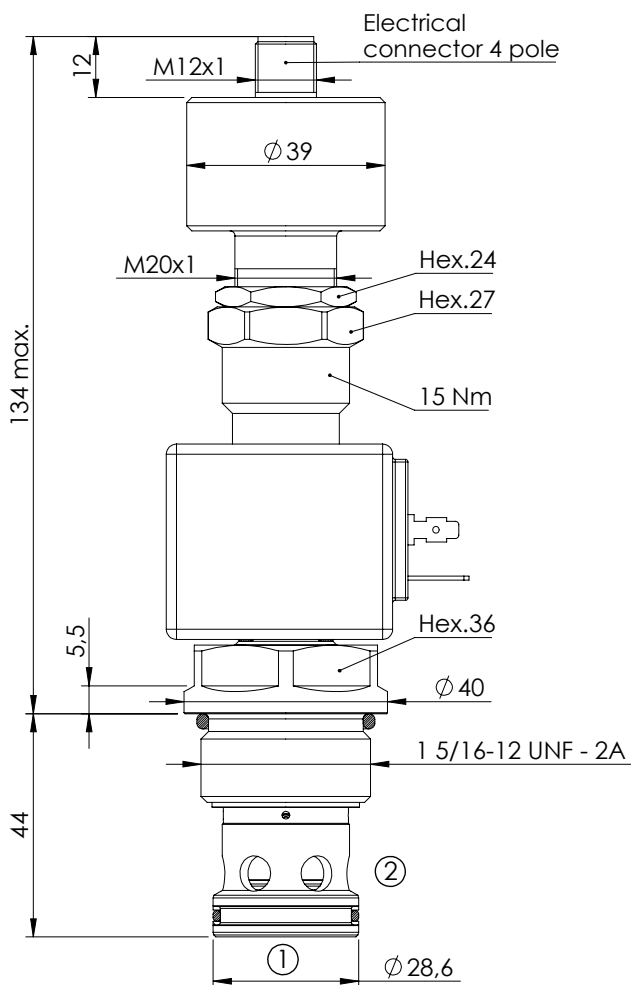

SPECIFICATIONS

Max. operating pressure:	350 bar
Rated flow:	300 l/min
Cavity:	SAE-16-2N
Weight:	0,7 kg
Coil type:	M7 type
Operating temperature:	-25/+80°C

NOTES

Installation torque:	118 - 132 Nm
Seal kit:	RB100084

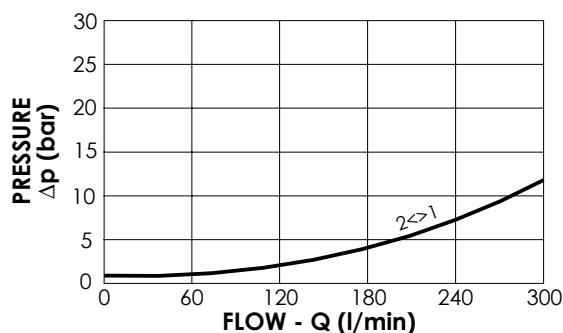

ORDERING CODES

Quick code	Description	Connector	Voltage	Options
CE001046	CEBN-300-NCDR-120-S16-V350-12HR	DIN 43650	12V DC	Proximity sensor
CE001068	CEBN-300-NCDR-120-S16-V350-24HR	DIN 43650	24V DC	Proximity sensor

SOLENOID OPERATED CARTRIDGE

CEBN-040-NADR

**POPET TYPE
PROXIMITY SENSOR**

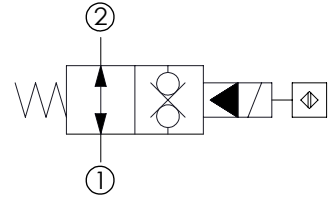
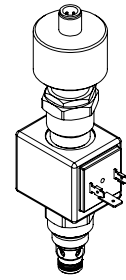
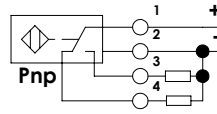
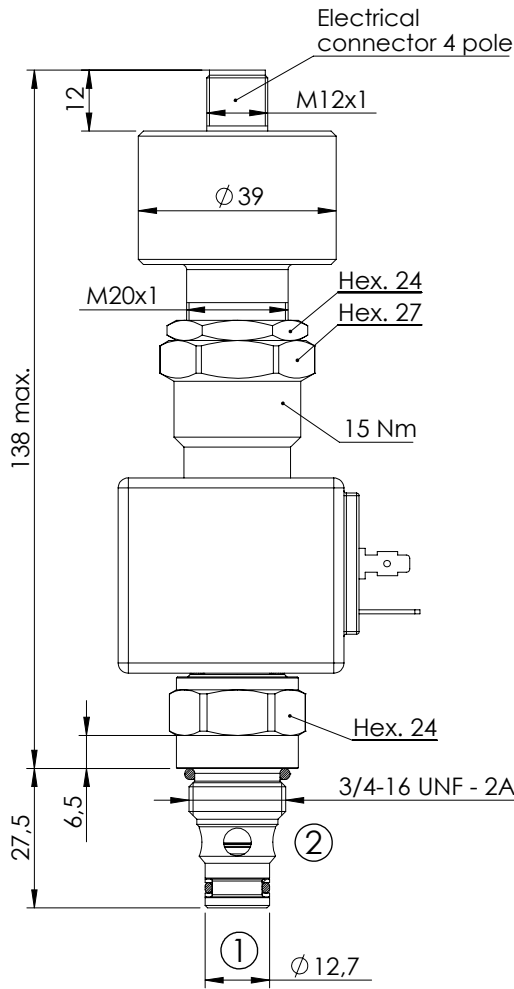

SPECIFICATIONS

Max. operating pressure:	350 bar
Rated flow:	40 l/min
Cavity:	SAE-08-2N
Weight:	0,5 kg
Coil type:	M7 type
Operating temperature:	-25/+80°C

NOTES

Installation torque:	45 - 50 Nm
Seal kit:	RB100081

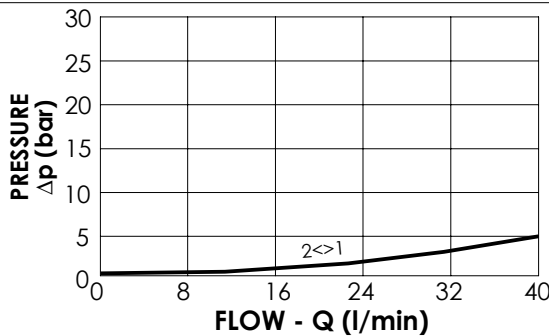

ORDERING CODES

Quick code	Description	Connector	Voltage	Options
CE001047	CEBN-040-NADR-121-S08-V350-12HR	DIN 43650	12V DC	Proximity sensor
CE001069	CEBN-040-NADR-121-S08-V350-24HR	DIN 43650	24V DC	Proximity sensor

SOLENOID OPERATED CARTRIDGE



CEBN-070-NADR

POPET TYPE PROXIMITY SENSOR

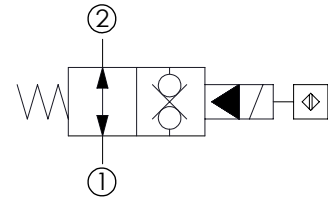
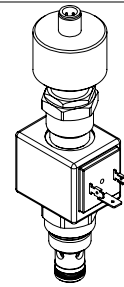
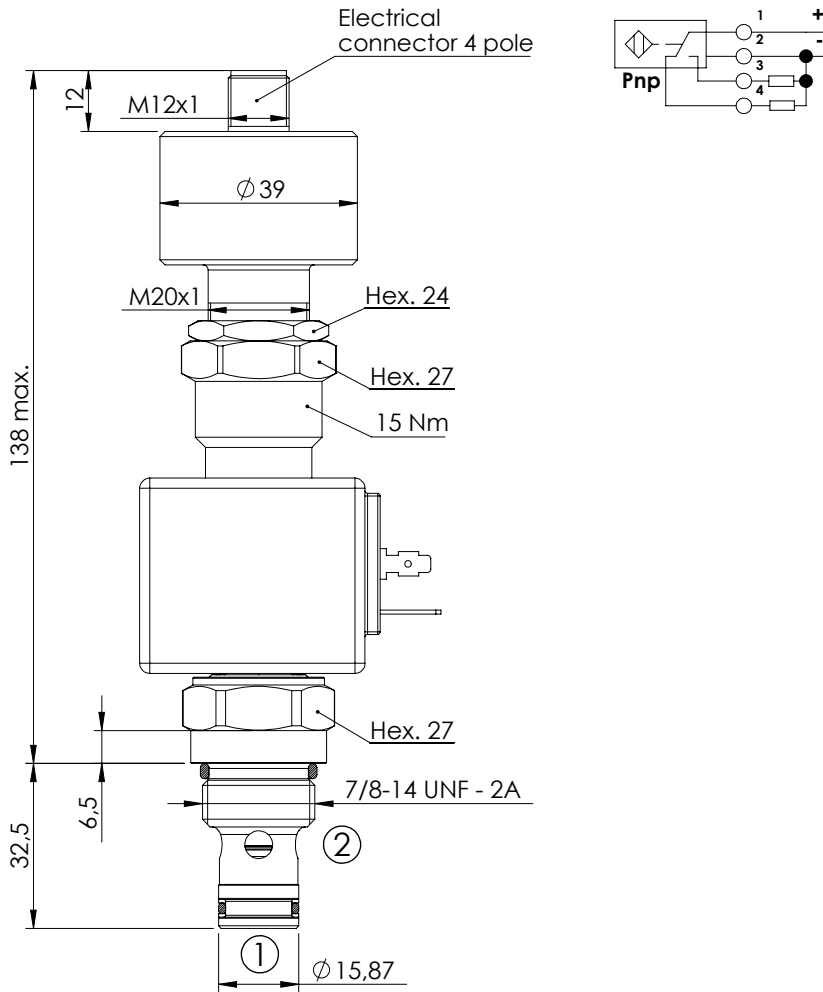

SPECIFICATIONS

Max. operating pressure:	350 bar
Rated flow:	70 l/min
Cavity:	SAE-10-2N
Weight:	0,53 kg
Coil type:	M7 type
Operating temperature:	-25/+80°C

NOTES

Installation torque:	55 - 62 Nm
Seal kit:	RB100082

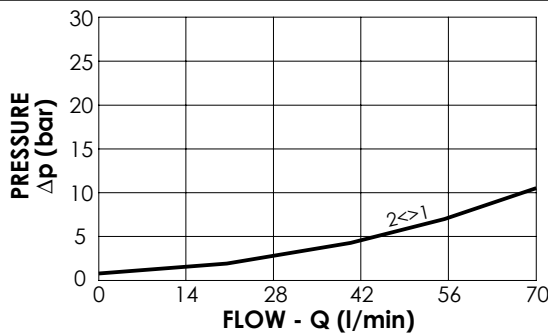

ORDERING CODES

Quick code	Description	Connector	Voltage	Options
CE001048	CEBN-070-NADR-121-S10-V350-12HR	DIN 43650	12V DC	Proximity sensor
CE001070	CEBN-070-NADR-121-S10-V350-24HR	DIN 43650	24V DC	Proximity sensor

SOLENOID OPERATED CARTRIDGE

CEBN-100-NAFN

POPPET TYPE PROXIMITY SENSOR

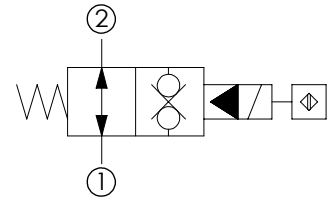
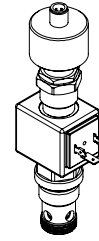
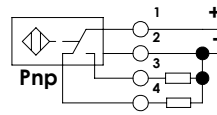
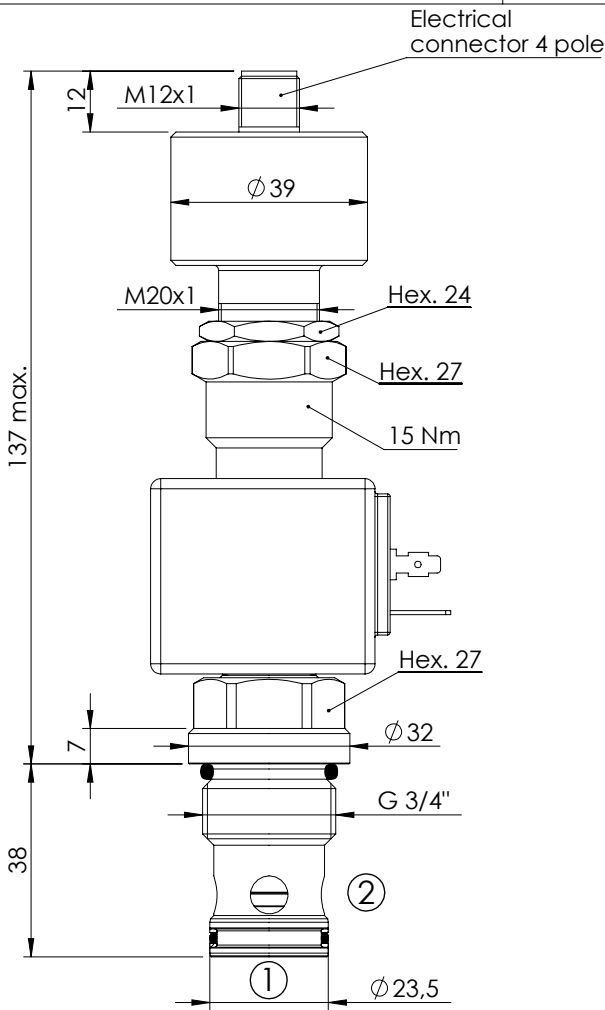

SPECIFICATIONS

Max. operating pressure:	350 bar
Rated flow:	100 l/min
Cavity:	VP000057
Weight:	0,6 kg
Coil type:	M7 type
Operating temperature:	-25/+80°C

NOTES

Installation torque:	110 - 130 Nm
Seal kit:	RD100057

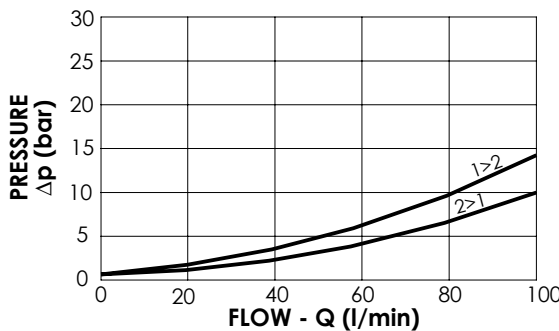

ORDERING CODES

Quick code	Description	Connector	Voltage	Options
CE001106	CEBN-100-NAFN-121-057-V350-12HR	DIN 43650	12V DC	Proximity sensor
CE001107	CEBN-100-NAFN-121-057-V350-24HR	DIN 43650	24V DC	Proximity sensor

SOLENOID OPERATED CARTRIDGE

CEBN-180-NAFN

**POPPET TYPE
PROXIMITY SENSOR**

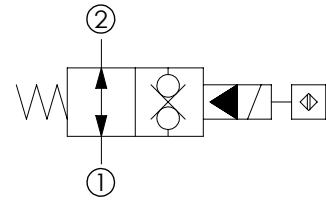
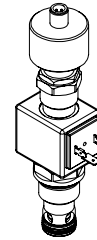
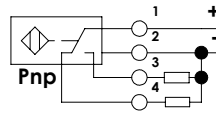
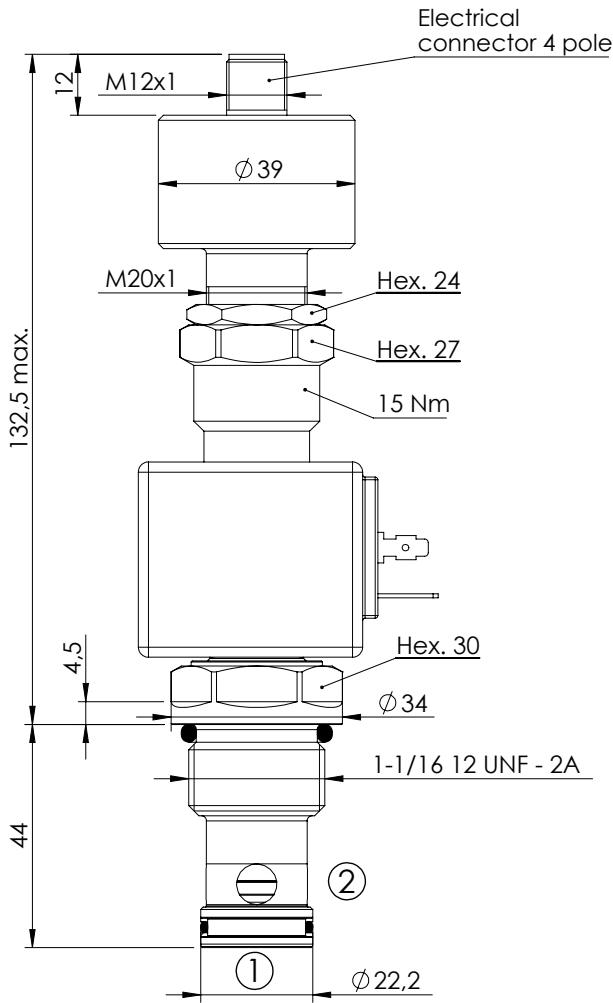

SPECIFICATIONS

Max. operating pressure:	350 bar
Rated flow:	180 l/min
Cavity:	SAE-12-2N
Weight:	0,6 kg
Coil type:	M7 type
Operating temperature:	-25/+80°C

NOTES

Installation torque:	135 - 150 Nm
Seal kit:	RB100083

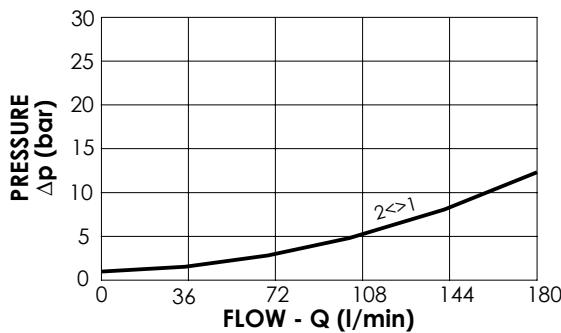

ORDERING CODES

Quick code	Description	Connector	Voltage	Options
CE001108	CEBN-180-NAFN-121-S12-V350-12HR	DIN 43650	12V DC	Proximity sensor
CE001109	CEBN-180-NAFN-121-S12-V350-24HR	DIN 43650	24V DC	Proximity sensor

SOLENOID OPERATED CARTRIDGE

CEBN-200-NAFN

**POPPET TYPE
PROXIMITY SENSOR**

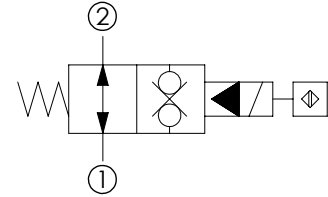
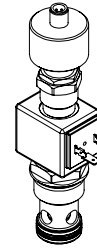
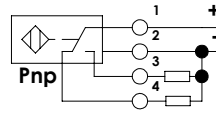
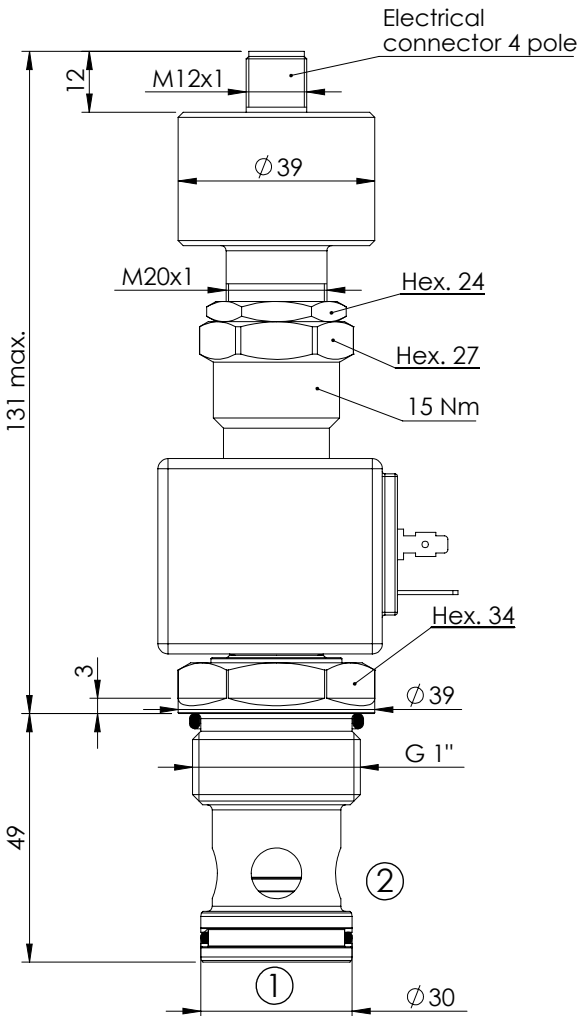

SPECIFICATIONS

Max. operating pressure:	350 bar
Rated flow:	200 l/min
Cavity:	VP000013
Weight:	0,71 kg
Coil type:	M7 type
Operating temperature:	-25/+80°C

NOTES

Installation torque:	135 - 150 Nm
Seal kit:	RD100013

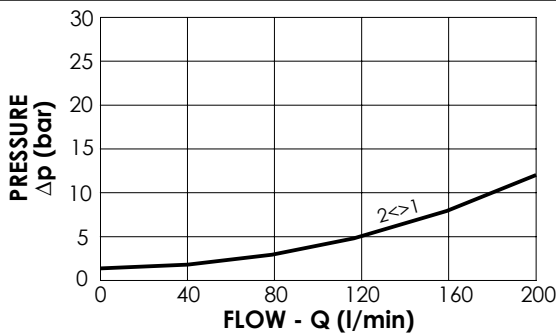

ORDERING CODES

Quick code	Description	Connector	Voltage	Options
CE001110	CEBN-200-NAFN-121-013-V350-12HR	DIN 43650	12V DC	Proximity sensor
CE001111	CEBN-200-NAFN-121-013-V350-24HR	DIN 43650	24V DC	Proximity sensor

SOLENOID OPERATED CARTRIDGE

CEBN-300-NADR

**POPPET TYPE
PROXIMITY SENSOR**

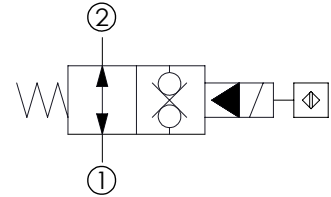
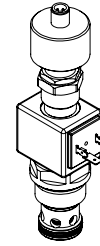
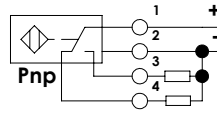
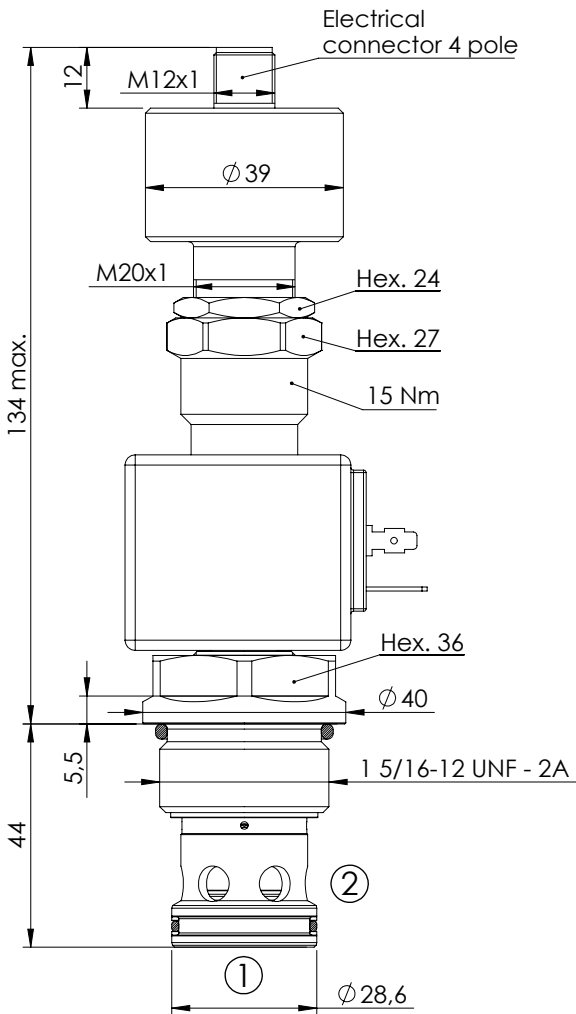

SPECIFICATIONS

Max. operating pressure:	350 bar
Rated flow:	300 l/min
Cavity:	SAE-16-2N
Weight:	0,72 kg
Coil type:	M7 type
Operating temperature:	-25/+80°C

NOTES

Installation torque:	118 - 132 Nm
Seal kit:	RB100084

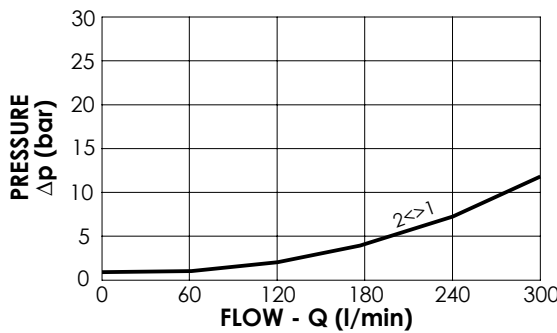

ORDERING CODES

Quick code	Description	Connector	Voltage	Options
CE001049	CEBN-300-NADR-121-S16-V350-12HR	DIN 43650	12V DC	Proximity sensor
CE001071	CEBN-300-NADR-121-S16-V350-24HR	DIN 43650	24V DC	Proximity sensor

SOLENOID OPERATED CARTRIDGE

CEBD-040-NAMV

**DIRECT OPERATED
POPPET TYPE
POSITION SENSOR**

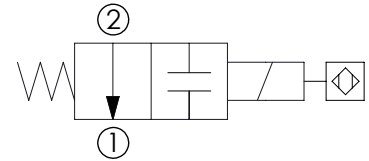
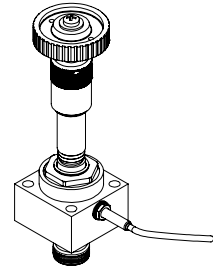
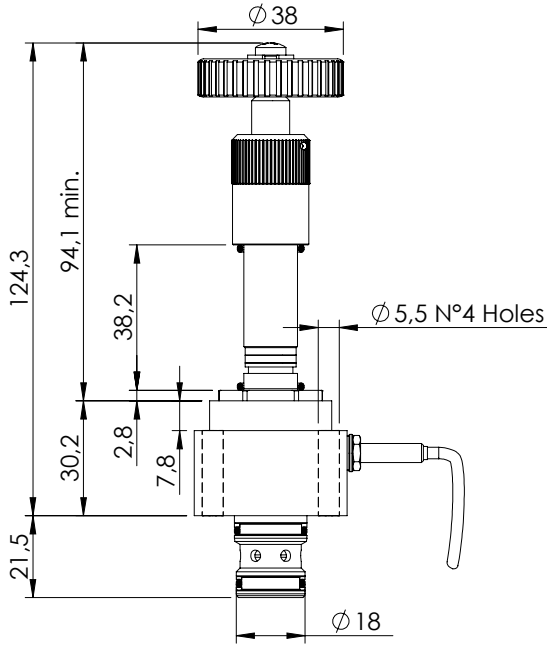
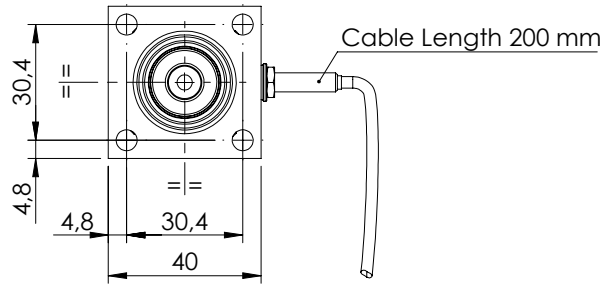
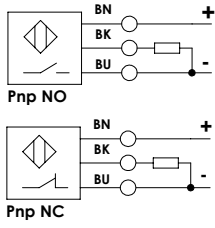

SPECIFICATIONS

Max. operating pressure:	350 bar
Rated flow:	40 l/min
Cavity:	VP000338
Weight:	0,4 kg
Coil type:	M14 type
Min. voltage required:	90% of nominal
Max. int. leakage:	200 cc/min (@46 cst)
Installation torque:	5 Nm
Seal kit:	RD700338

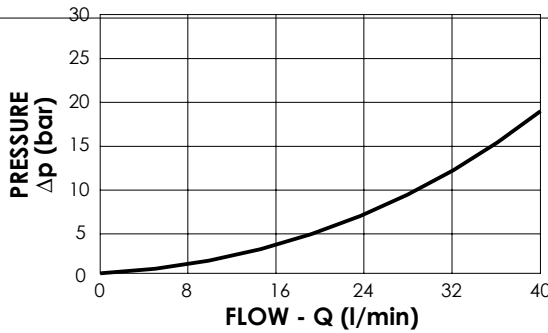

NOTES

- To be mounted with M5x30 screws
- Maximum pressure in ②: 100 bar

ORDERING CODES

Quick code	Description	Sensor type
CE000818	CEBD-040-NAMV-97-338-N350	Valve not energized Sensor open (PNP-NO)
CE000819	CEBD-040-NACV-97-338-N350	Valve not energized Sensor closed (PNP-NC)

SOLENOID OPERATED CARTRIDGE

CEBT-300-NCFN

**PILOTED RELIEF
SPOOL TYPE**

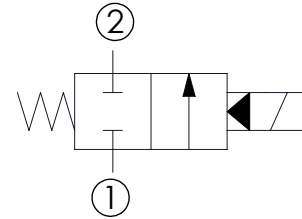
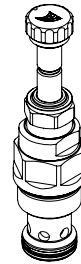
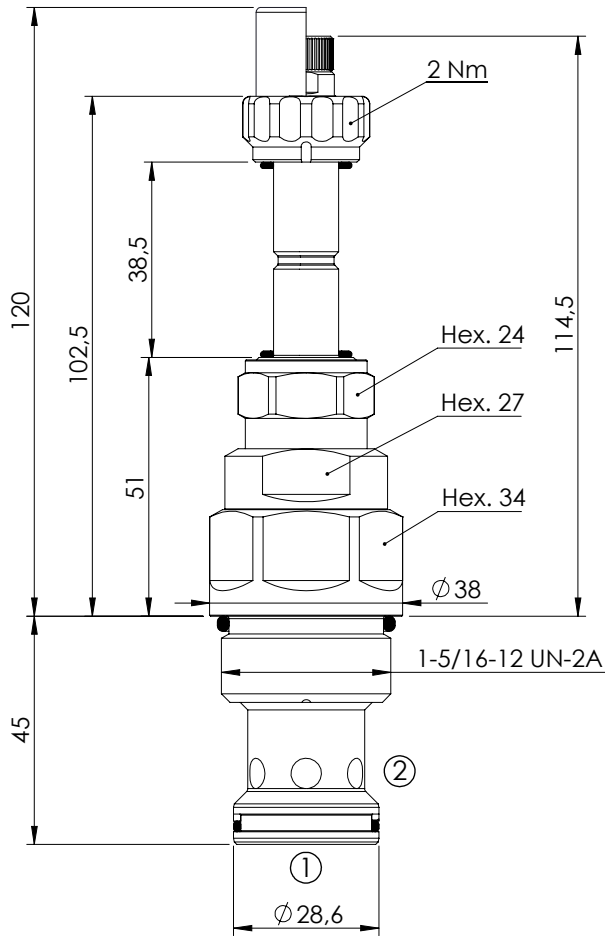

SPECIFICATIONS

Max. operating pressure:	350 bar
Rated flow:	300 l/min
Cavity:	SAE-16-2N
Weight:	0,5 kg
Coil type:	M7 type
Max. int. leakage:	350 cm ³ /min (@46 cSt)
Seal kit:	RA900084

NOTES

Installation torque: 118 - 132 Nm

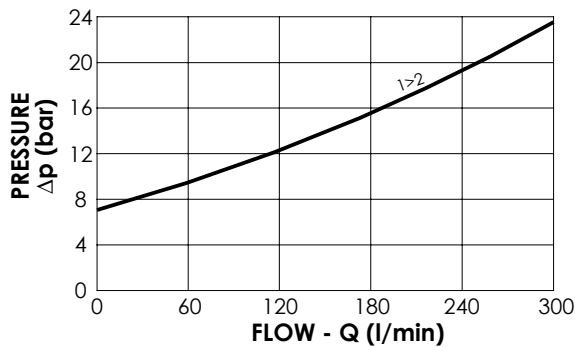

OPTIONS

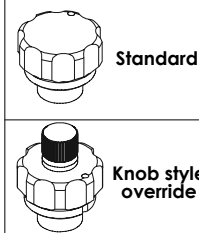

SEALING CAP

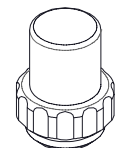

Ordering code:
AT000113

ORDERING CODES

Quick code	Description	Options
CE000913	CEBT-300-NCFN-98-S16-N350	Standard
CE000914	CEBT-300-NCFE-98-S16-N350	Knob style override

SOLENOID OPERATED CARTRIDGE

CEBT-500-NCFN

**PILOTED OPERATED
SPOOL TYPE**

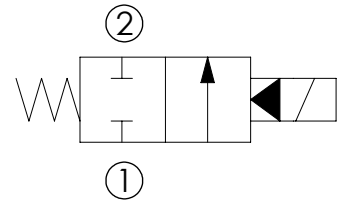
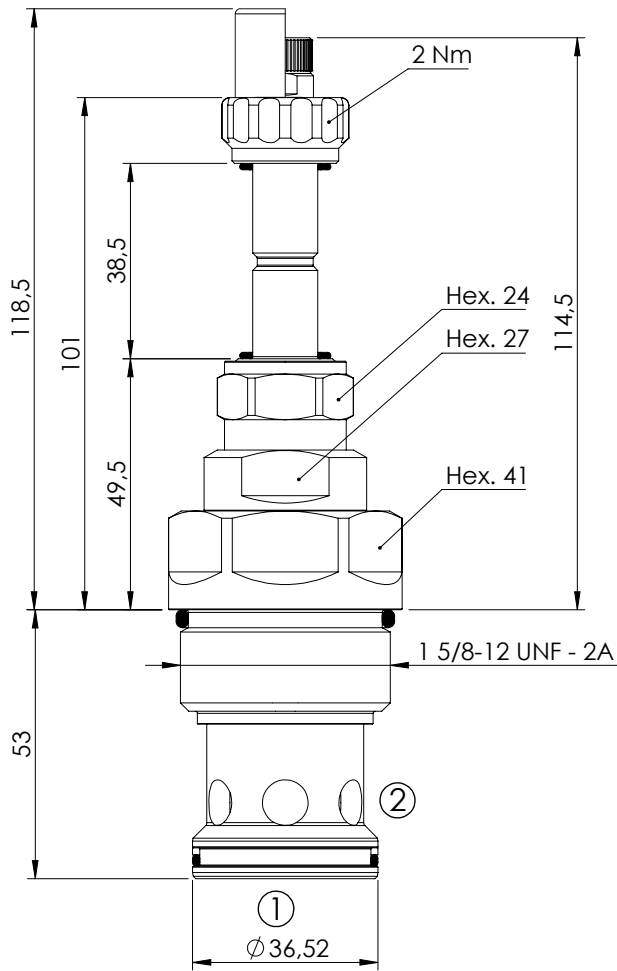

SPECIFICATIONS

Max. operating pressure:	350 bar
Rated flow:	500 l/min
Cavity:	SAE-20-2N
Weight:	0,7 kg
Coil type:	M7 type
Max. int. leakage:	400 cm ³ /min (@46 cSt)
Seal kit:	RA900085

NOTES

Installation torque: 230 - 250 Nm

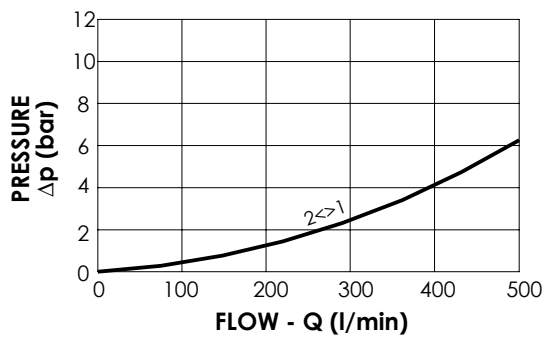

OPTIONS

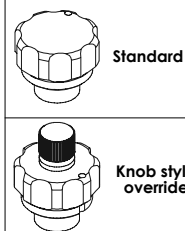

SEALING CAP

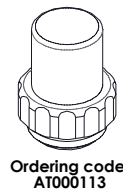

ORDERING CODES

Quick code	Description	Options
CE000763	CEBT-500-NCFN-98-S20-N350	Standard
CE000764	CEBT-500-NCFK-98-S20-N350	Knob style override

SOLENOID OPERATED CARTRIDGE

CEBT-300-NAFN

**PILOTED RELIEF
SPOOL TYPE**

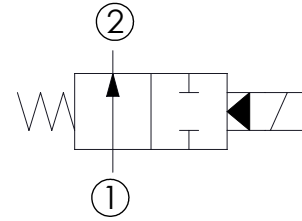
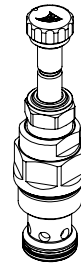
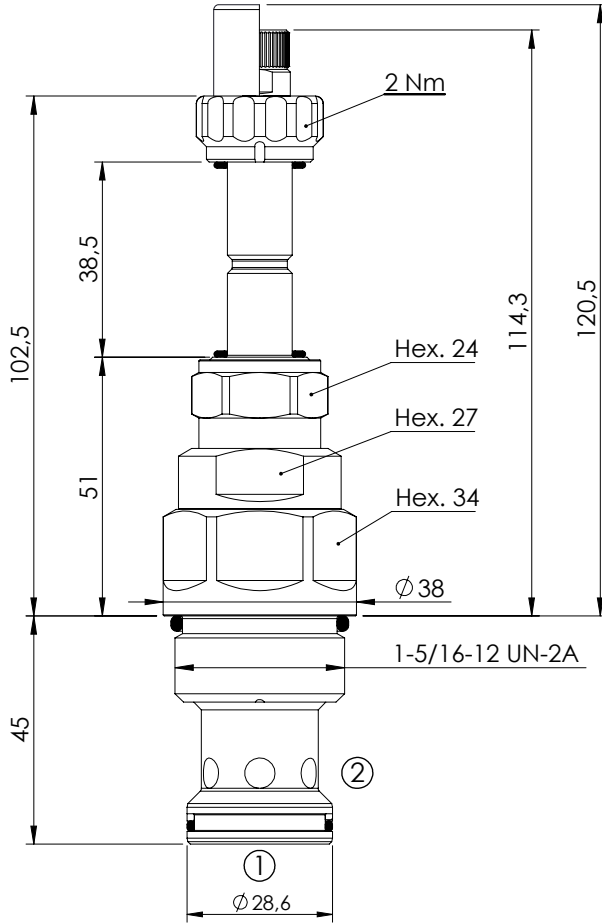

SPECIFICATIONS

Max. operating pressure:	350 bar
Rated flow:	300 l/min
Cavity:	SAE-16-2N
Weight:	0,5 kg
Coil type:	M7 type
Max. int. leakage:	350 cm ³ /min (@46 cSt)
Seal kit:	RA900084

NOTES

Installation torque: 118 - 132 Nm

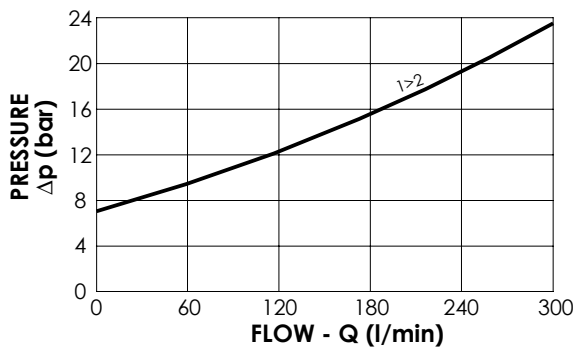

OPTIONS

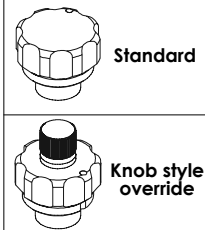

SEALING CAP

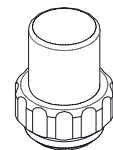

Ordering code:
AT000113

ORDERING CODES

Quick code	Description	Options
CE000861	CEBT-300-NAFN-99-S16-N350	Standard
CE000888	CEBT-300-NAFE-99-S16-N350	Knob style override

SOLENOID OPERATED CARTRIDGE

CEBT-500-NAFN

**PILOTED OPERATED
SPOOL TYPE**

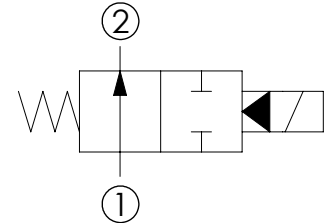
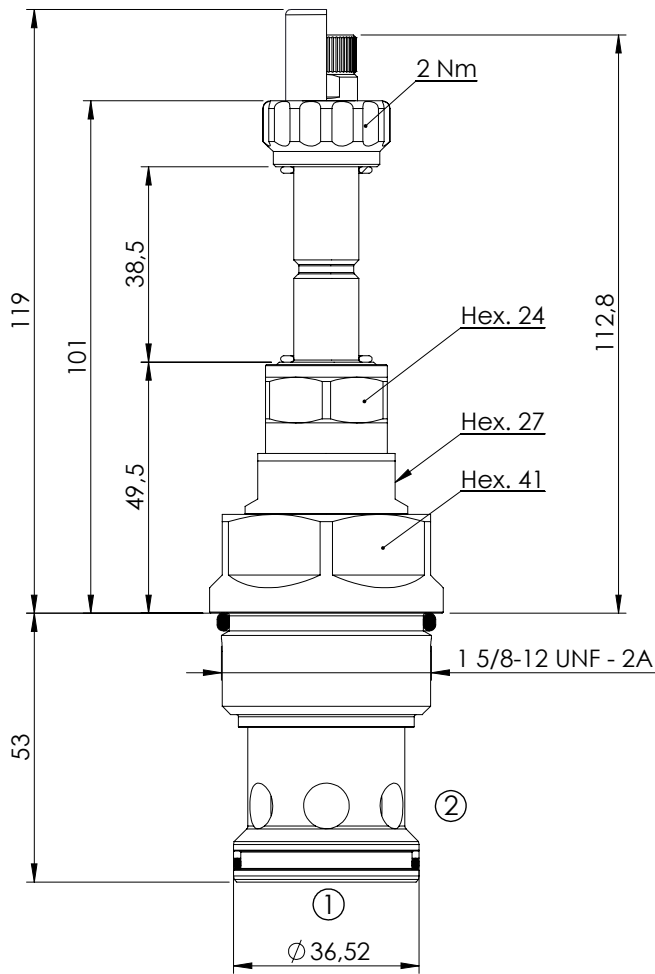

SPECIFICATIONS

Max. operating pressure:	350 bar
Rated flow:	500 l/min
Cavity:	SAE-20-2N
Weight:	0,7 kg
Coil type:	M7 type
Max. int. leakage:	400 cm ³ /min (@46 cst)
Seal kit:	RA900085

NOTES

Installation torque: 230 - 250 Nm

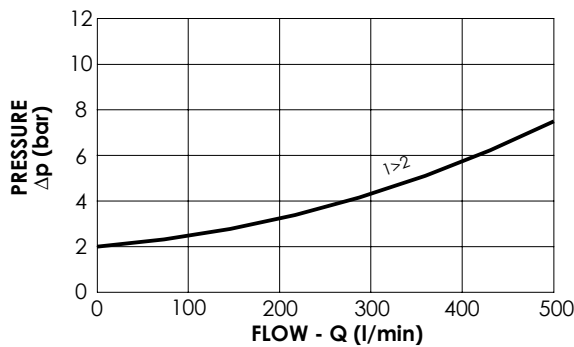

OPTIONS

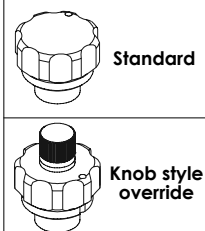

SEALING CAP

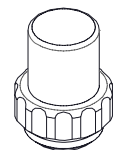

Ordering code:
AT000113

ORDERING CODES

Quick code	Description	Options
CE000765	CEBT-500-NAFN-99-S20-N350	Standard
CE000766	CEBT-500-NAFK-99-S20-N350	Knob style override

SOLENOID OPERATED CARTRIDGE

CEBN-040-NCAN

**PNEUMATIC OPERATED
POPPET TYPE**

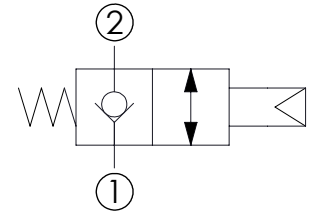
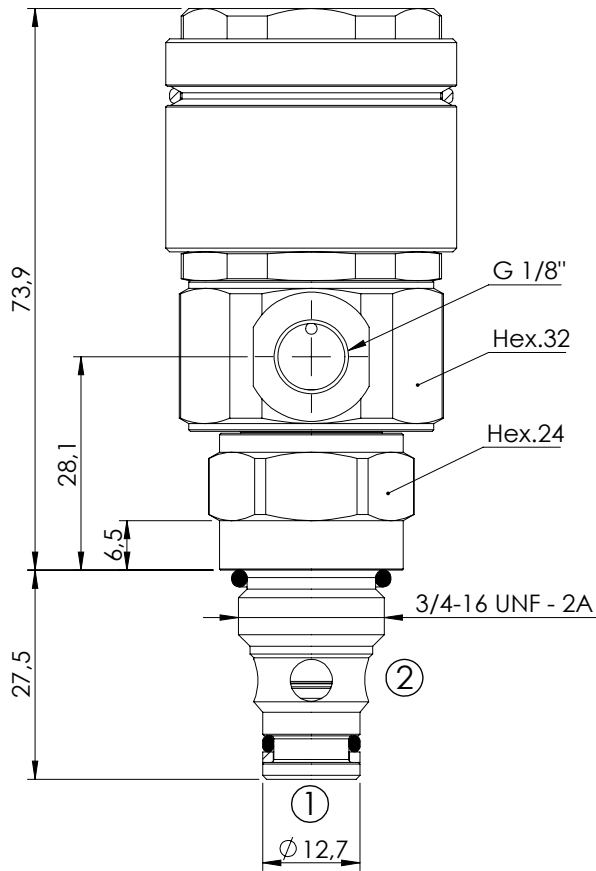
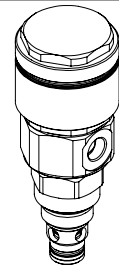

SPECIFICATIONS

Max. operating pressure:	350 bar
Rated flow:	40 l/min
Cavity:	SAE-08-2N
Weight:	0,31 kg
Seal kit:	RA900081

NOTES

Installation torque: **45 - 50 Nm**

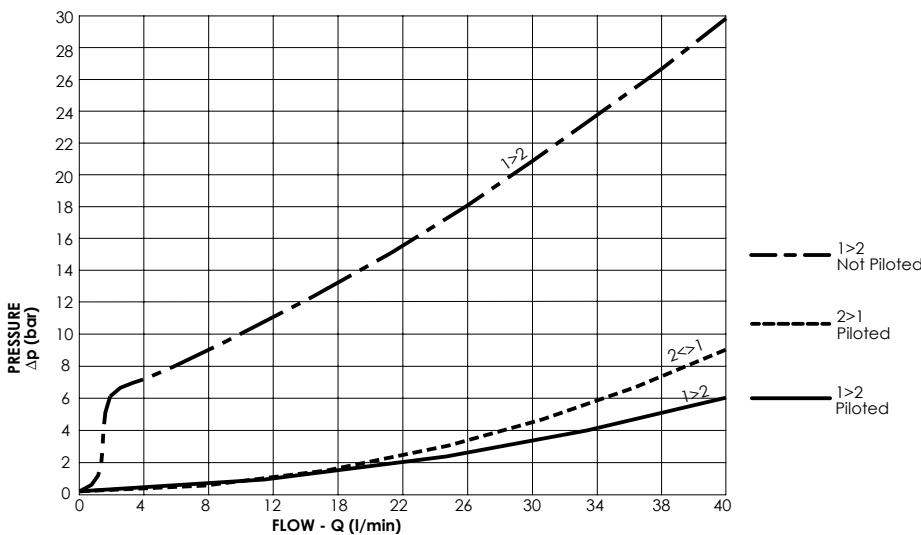

ORDERING CODES

Quick code	Description	Pneumatic pilot pressure (bar)	
		Min. 4	Max. 10
CE000961	CEBN-040-NCAN-123-S08-N350		

SOLENOID OPERATED CARTRIDGE

CEBN-200-NCAN

PNEUMATIC OPERATED
POPPET TYPE

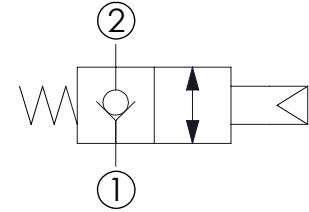
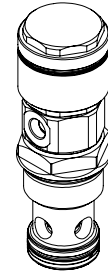
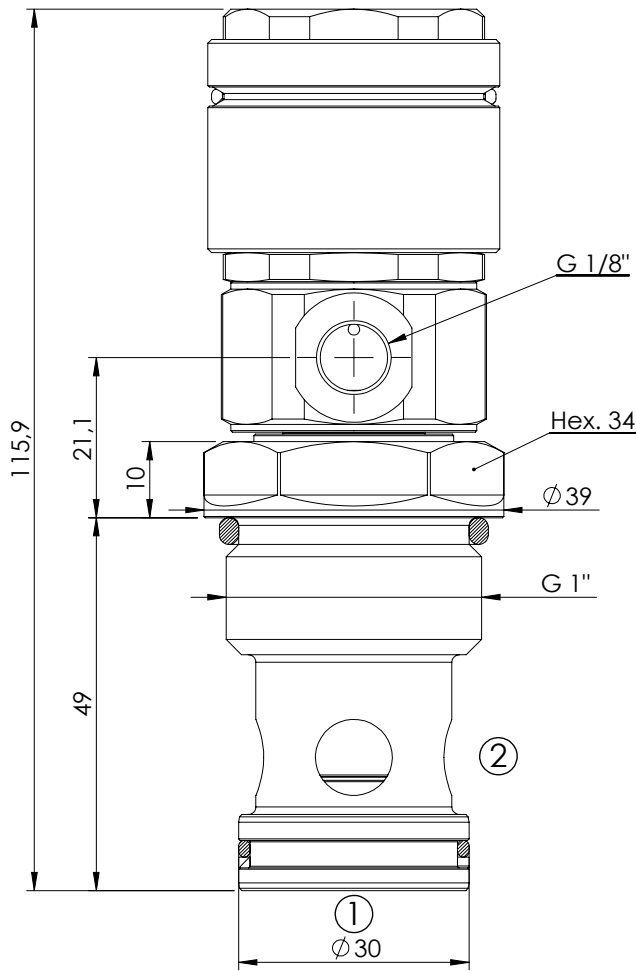

SPECIFICATIONS

Max. operating pressure:	350 bar
Rated flow:	200 l/min
Cavity:	VP000013
Weight:	0,52 kg
Seal kit:	RA900013

NOTES

Installation torque: 135 - 150 Nm

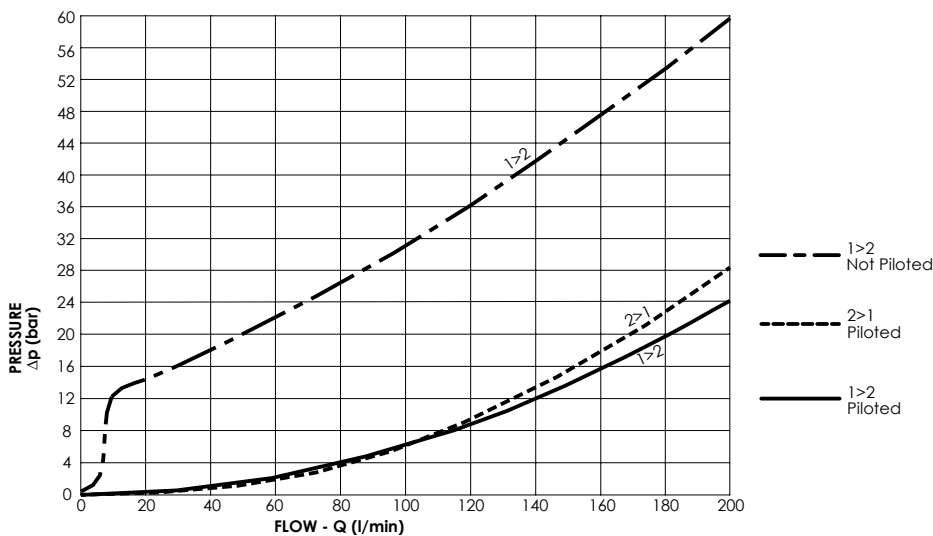

ORDERING CODES

Quick code	Description	Pneumatic pilot pressure (bar)	
CE000883	CEBN-200-NCAN-123-013-N350	Min. 4	Max. 10

SOLENOID OPERATED CARTRIDGE

CECS-010-SEFN

**DIRECT OPERATED
SPOOL TYPE**

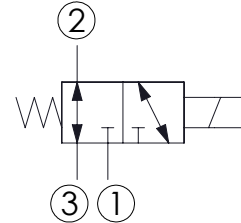
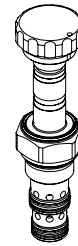
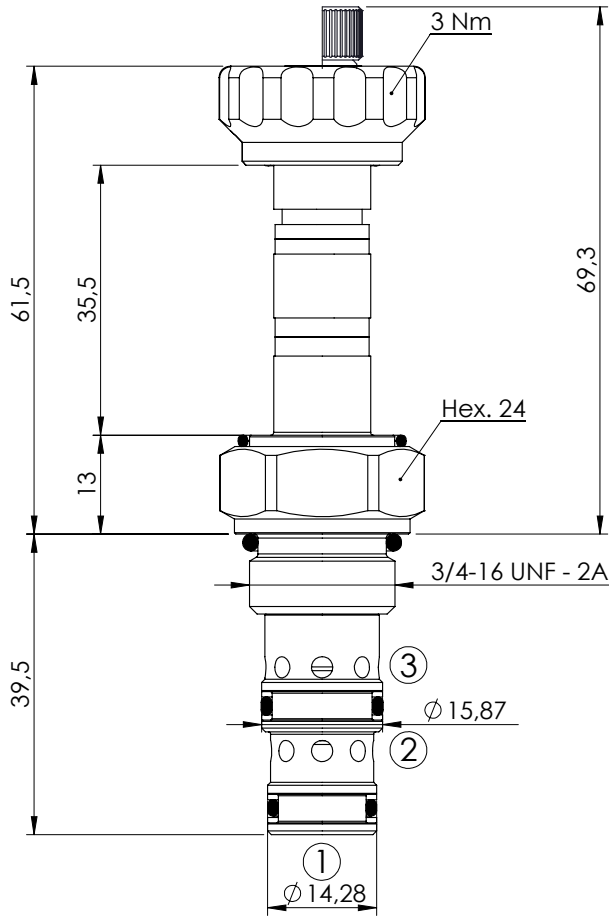

SPECIFICATIONS

Max. operating pressure:	210 bar
Rated flow:	10 l/min
Cavity:	SAE-08-3N
Weight:	0,14 kg
Min. voltage required:	90% of nominal
Coil type:	M7 type
Leakage:	120cm ³ /min
Seal kit:	RB700091

NOTES

Installation torque: 45 - 50 Nm

OPTIONS

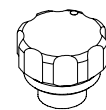

Standard

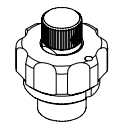

Knob style
override

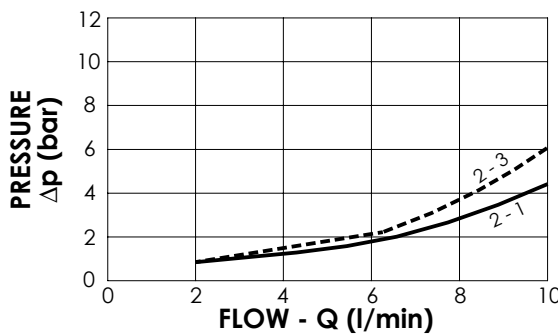

ORDERING CODES

Quick code	Description	Options	
CE000009	CECS-010-SEFN-61-S08-N210	Standard	
CE000066	CECS-010-SEFE-61-S08-N210	Knob style override	

SOLENOID OPERATED CARTRIDGE

CECS-010-SEFN

**DIRECT OPERATED
SPOOL TYPE**

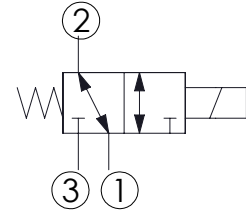
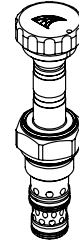
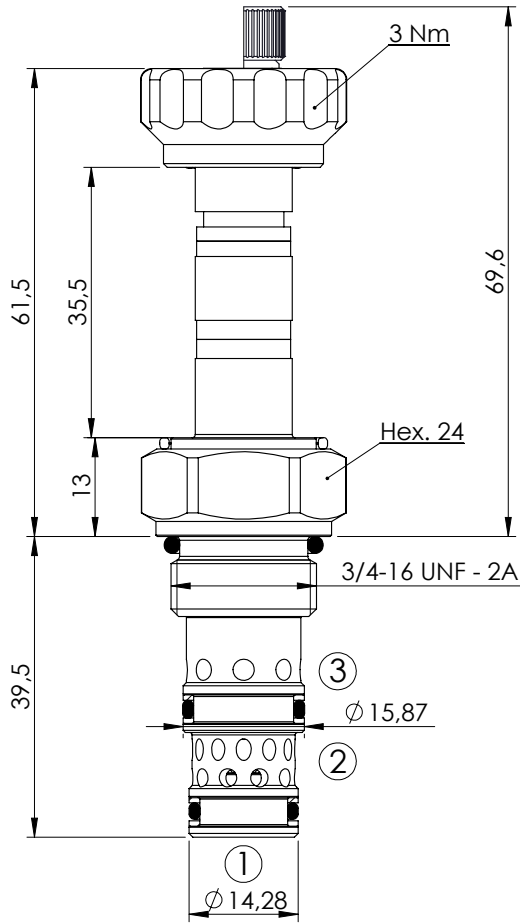

SPECIFICATIONS

Max. operating pressure:	210 bar
Rated flow:	10 l/min
Cavity:	SAE-08-3N
Weight:	0,14 kg
Min. voltage required:	90% of nominal
Coil type:	M7 type
Leakage:	120cm ³ /min
Seal kit:	RB700091

NOTES

Installation torque: 45 - 50 Nm

OPTIONS

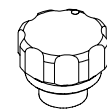

Standard

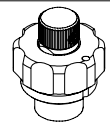

Knob style override

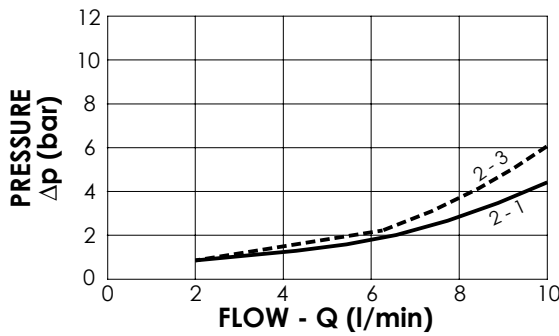

ORDERING CODES

Quick code	Description	Options	
CE000010	CECS-010-SEFN-62-S08-N210	Standard	
CE000067	CECS-010-SEFE-62-S08-N210	Knob style override	

SOLENOID OPERATED CARTRIDGE



CECS-010-SEFN

**DIRECT OPERATED
SPOOL TYPE**

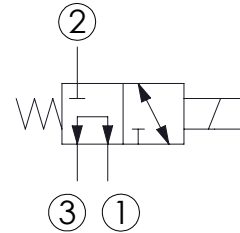
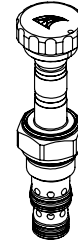
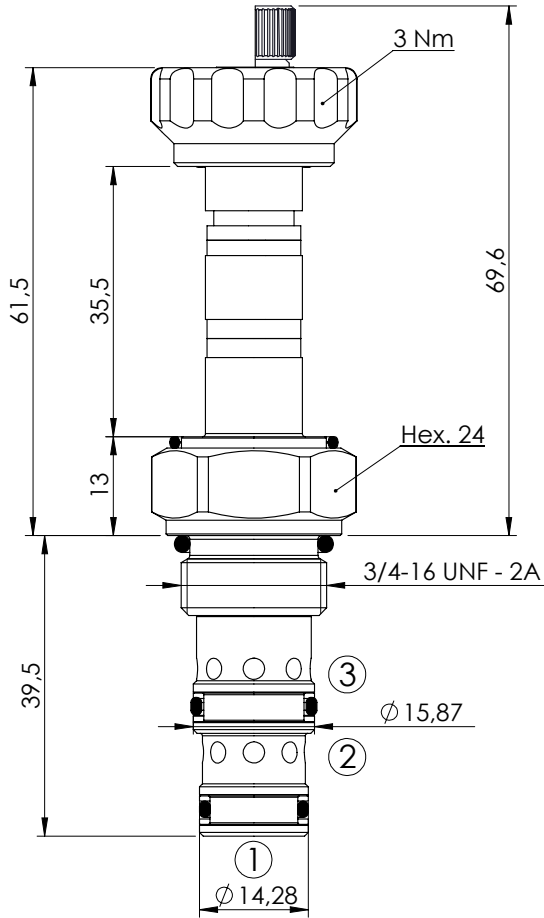

SPECIFICATIONS

Max. operating pressure:	210 bar
Rated flow:	10 l/min
Cavity:	SAE-08-3N
Weight:	0,14 kg
Min. voltage required:	90% of nominal
Coil type:	M7 type
Leakage:	120cm ³ /min
Seal kit:	RB700091

NOTES

Installation torque: 45 - 50 Nm

OPTIONS

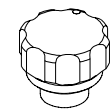

Standard

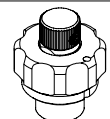

Knob style
override

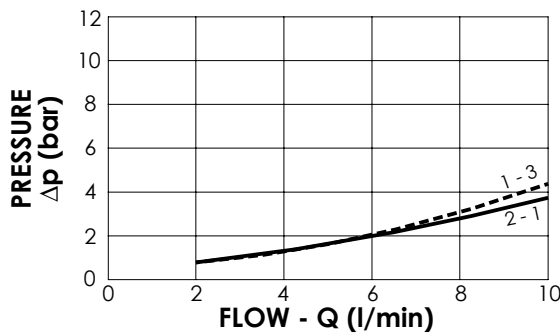

ORDERING CODES

Quick code	Description	Options	
CE000011	CECS-010-SEFN-63-S08-N210	Standard	
CE000068	CECS-010-SEFE-63-S08-N210	Knob style override	

SOLENOID OPERATED CARTRIDGE

CECS-010-SEFN

**DIRECT OPERATED
SPOOL TYPE**

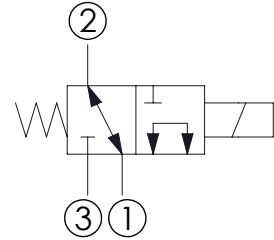
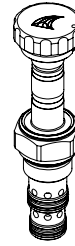
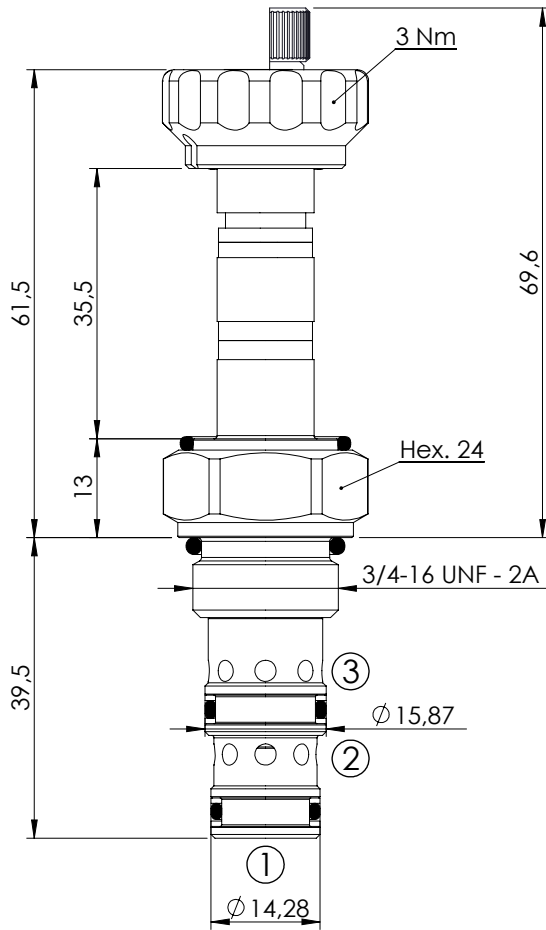

SPECIFICATIONS

Max. operating pressure:	210 bar
Rated flow:	10 l/min
Cavity:	SAE-08-3N
Weight:	0,14 kg
Min. voltage required:	90% of nominal
Coil type:	M7 type
Leakage:	120cm ³ /min
Seal kit:	RB700091

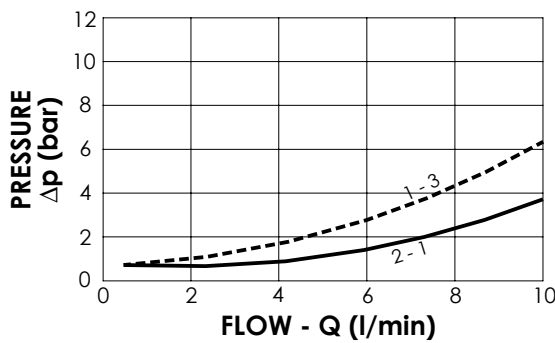

NOTES

Installation torque: 45 - 50 Nm

OPTIONS

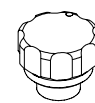

Standard

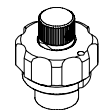

Knob style
override

ORDERING CODES

Quick code	Description	Options	
CE000008	CECS-010-SEFN-64-S08-N210	Standard	
CE000070	CECS-010-SEFE-64-S08-N210	Knob style override	

SOLENOID OPERATED CARTRIDGE

CEDS-010-SEFN

**DIRECT OPERATED
SPOOL TYPE**

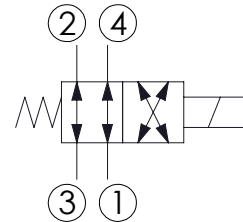
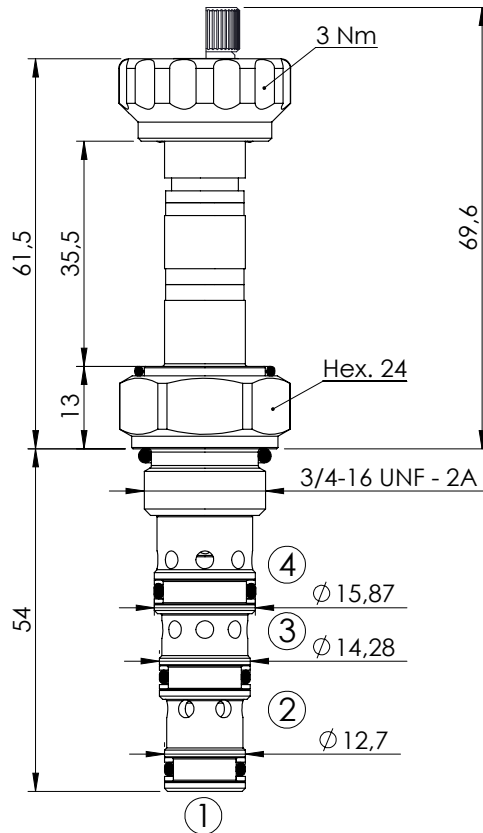

SPECIFICATIONS

Max. operating pressure:	210 bar
Rated flow:	10 l/min
Cavity:	SAE-08-4N
Weight:	0,14 kg
Min. voltage required:	90% of nominal
Coil type:	M7 type
Leakage:	120cm ³ /min
Seal kit:	RB700101

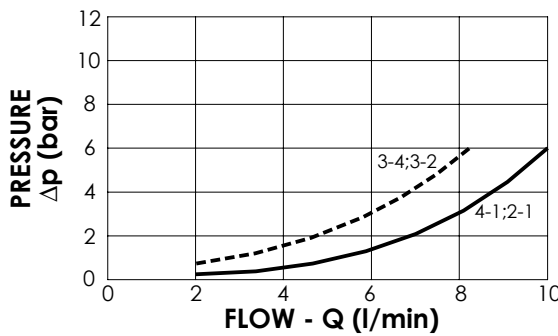

NOTES

Installation torque: 45 - 50 Nm

OPTIONS

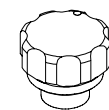

Standard

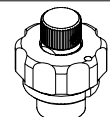

Knob style
override

ORDERING CODES

Quick code	Description	Options	
CE000014	CEDS-010-SEFN-40-S08-N210	Standard	
CE000071	CEDS-010-SEFE-40-S08-N210	Knob style override	

SOLENOID OPERATED CARTRIDGE

CEDS-010-SEFN

**DIRECT OPERATED
SPOOL TYPE**

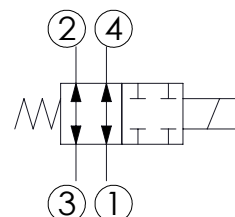
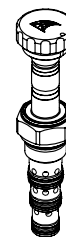
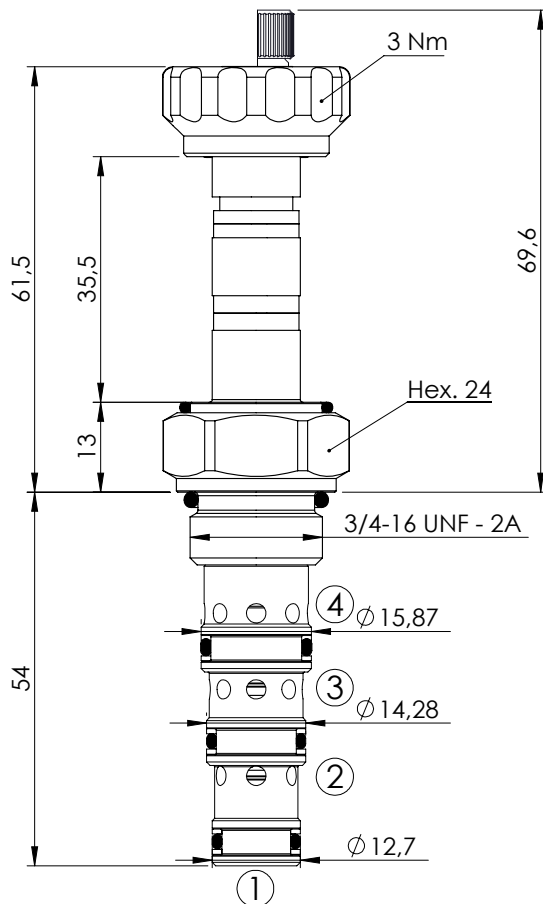

SPECIFICATIONS

Max. operating pressure:	210 bar
Rated flow:	10 l/min
Cavity:	SAE-08-4N
Weight:	0,14 kg
Min. voltage required:	90% of nominal
Coil type:	M7 type
Leakage:	120cm ³ /min
Seal kit:	RB700101

NOTES

Installation torque: 45 - 50 Nm

OPTIONS

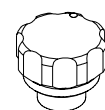

Standard

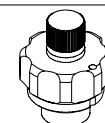

Knob style override

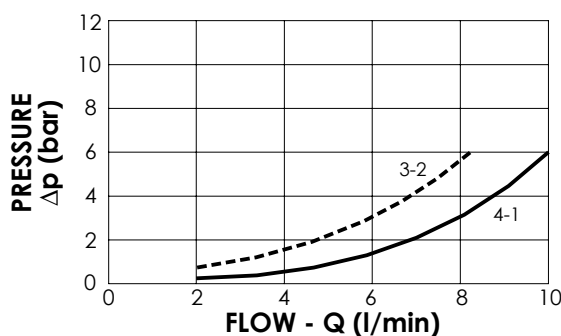

ORDERING CODES

Quick code	Description	Options	
CE000867	CEDS-010-SEFN-49-S08-N210	Standard	
CE000787	CEDS-010-SEFE-49-S08-N210	Knob style override	

SOLENOID OPERATED CARTRIDGE

CEDS-010-SEFN

**DIRECT OPERATED
SPOOL TYPE**

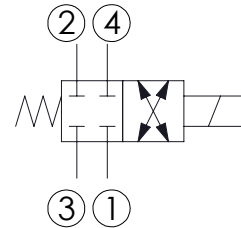
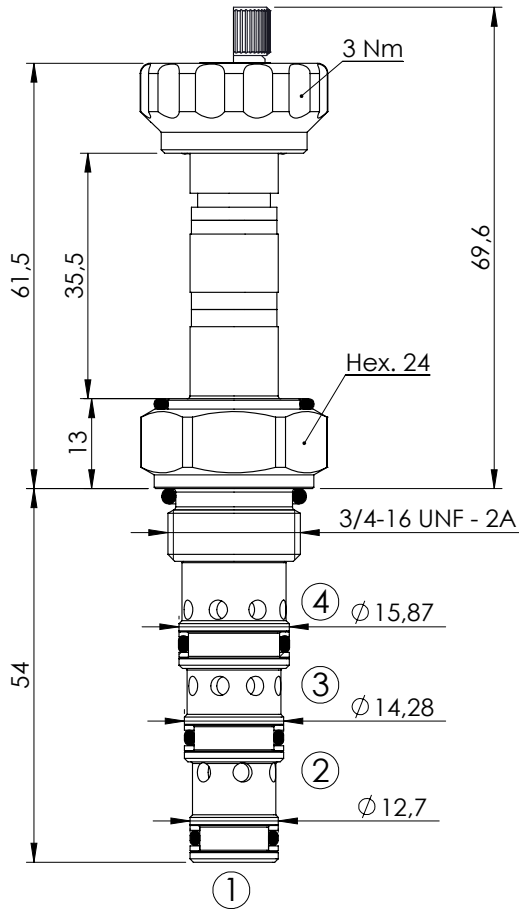

SPECIFICATIONS

Max. operating pressure:	210 bar
Rated flow:	10 l/min
Cavity:	SAE-08-4N
Weight:	0,14 kg
Min. voltage required:	90% of nominal
Coil type:	M7 type
Leakage:	120cm ³ /min
Seal kit:	RB700101

NOTES

Installation torque: **45 - 50 Nm**

OPTIONS

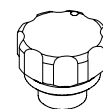

Standard

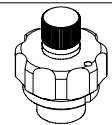

Knob style
override

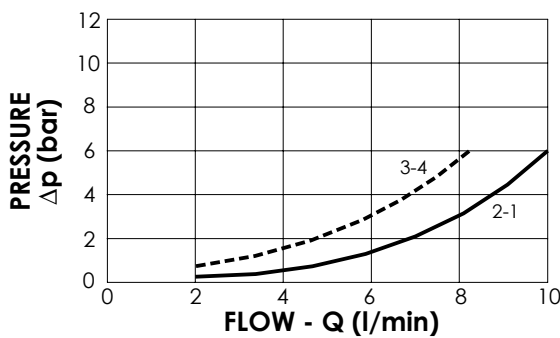

ORDERING CODES

Quick code	Description	Options	
CE000012	CEDS-010-SEFN-41-S08-N210	Standard	
CE000073	CEDS-010-SEFE-41-S08-N210	Knob style override	

SOLENOID OPERATED CARTRIDGE

CEDS-010-SEFN

DIRECT OPERATED
SPOOL TYPE

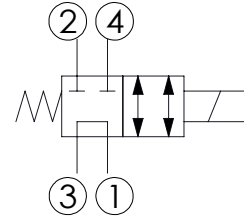
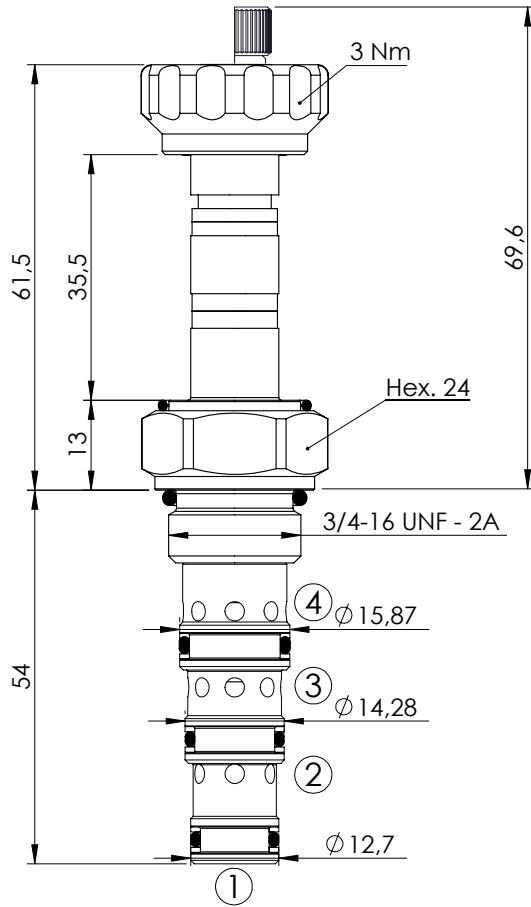

SPECIFICATIONS

Max. operating pressure:	210 bar
Rated flow:	10 l/min
Cavity:	SAE-08-4N
Weight:	0,14 kg
Min. voltage required:	90% of nominal
Coil type:	M7 type
Leakage:	120cm ³ /min
Seal kit:	RB700101

NOTES

Installation torque: 45 - 50 Nm

OPTIONS

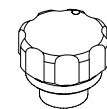

Standard

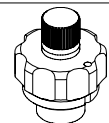

Knob style
override

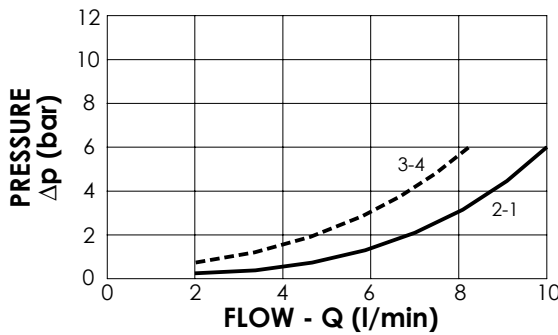

ORDERING CODES

Quick code	Description	Options	
CE000006	CEDS-010-SEFN-43-S08-N210	Standard	
CE000074	CEDS-010-SEFE-43-S08-N210	Knob style override	

SOLENOID OPERATED CARTRIDGE

CEES-010-SEFN

**DIRECT OPERATED
SPOOL TYPE**

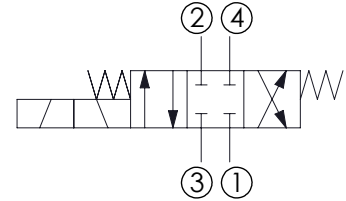
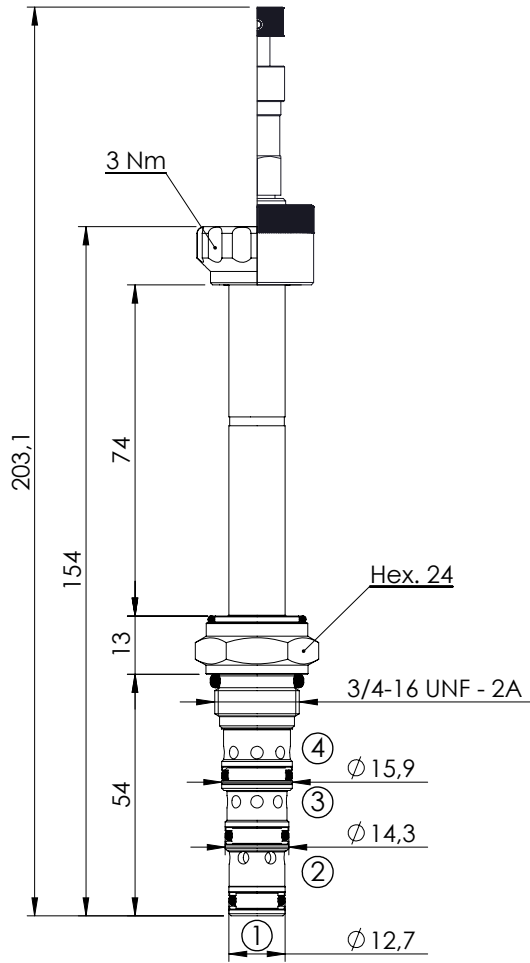

SPECIFICATIONS

Max. operating pressure:	210 bar
Rated flow:	10 l/min
Cavity:	SAE-08-4N
Weight:	0,18 kg
Min. voltage required:	90% of nominal
Coil type:	M7 type
Leakage:	120cm ³ /min
Seal kit:	RB700101

NOTES

Installation torque: 45 - 50 Nm

OPTIONS



Standard

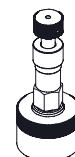

Push and pull manual override

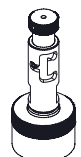

Push pull and twist manual override

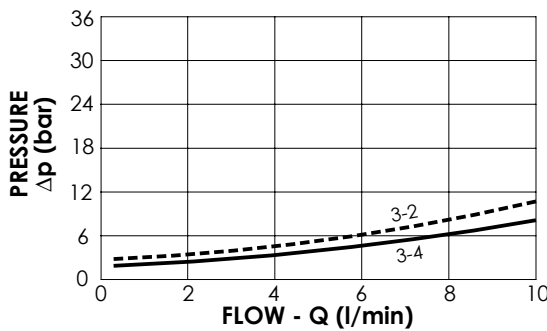

ORDERING CODES

Quick code	Description	Options	
CE000028	CEES-010-SEFN-51-S08-N210	Standard	
CE000098	CEES-010-SEFL-51-S08-N210	Push and pull manual override	
CE000189	CEES-010-SEFG-51-S08-N210	Push pull and twist manual override	

SOLENOID OPERATED CARTRIDGE

CEES-010-SEFN

**DIRECT OPERATED
SPOOL TYPE**

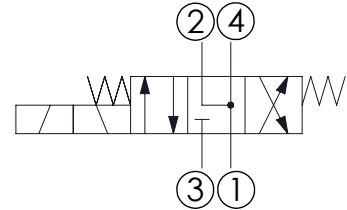
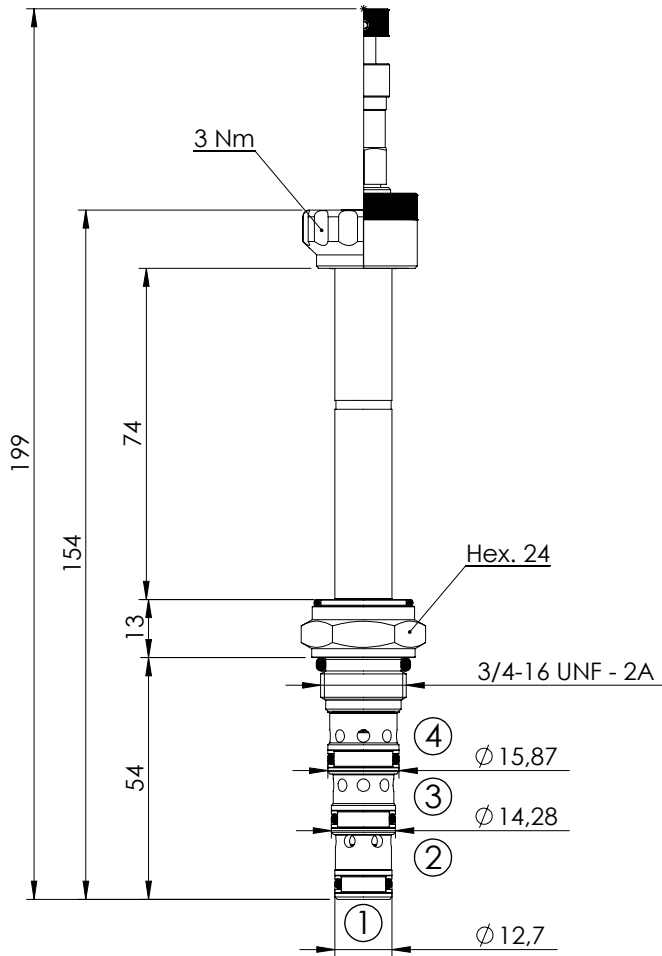

SPECIFICATIONS

Max. operating pressure:	210 bar
Rated flow:	10 l/min
Cavity:	SAE-08-4N
Weight:	0,18 kg
Min. voltage required:	90% of nominal
Coil type:	M7 type
Leakage:	120cm ³ /min
Seal kit:	RB700101

NOTES

Installation torque: 45 - 50 Nm

OPTIONS

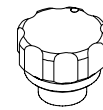

Standard

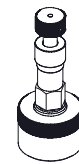

Push and pull manual override

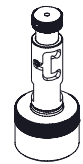

Push pull and twist manual override

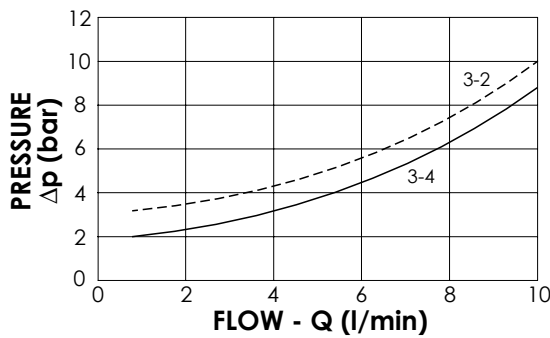

ORDERING CODES

Quick code	Description	Options	
CE000029	CEES-010-SEFN-52-S08-N210	Standard	
CE000095	CEES-010-SEFL-52-S08-N210	Push and pull manual override	
CE000145	CEES-010-SEFG-52-S08-N210	Push pull and twist manual override	

SOLENOID OPERATED CARTRIDGE

CEES-010-SEFN

**DIRECT OPERATED
SPOOL TYPE**

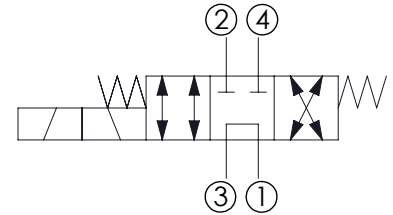
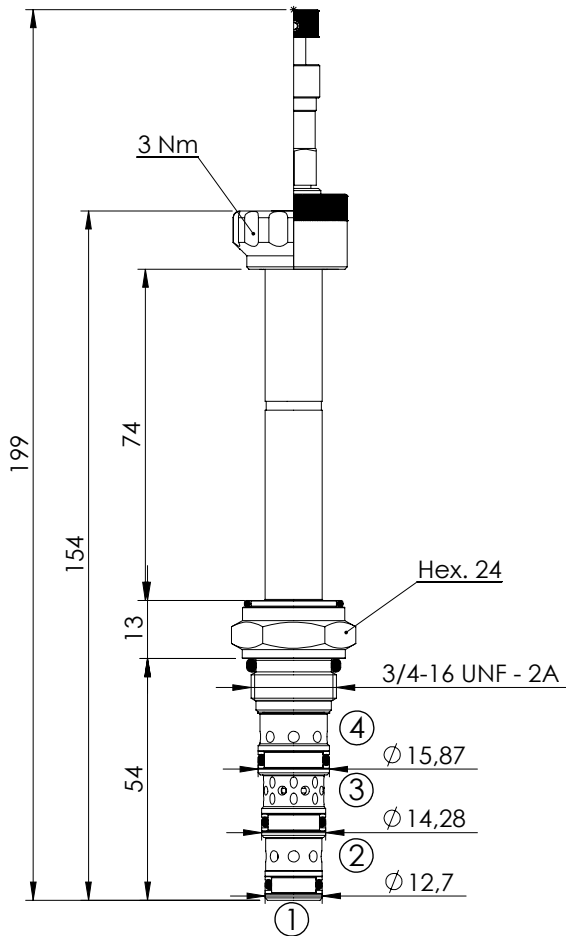

SPECIFICATIONS

Max. operating pressure:	210 bar
Rated flow:	10 l/min
Cavity:	SAE-08-4N
Weight:	0,18 kg
Min. voltage required:	90% of nominal
Coil type:	M7 type
Leakage:	120cm ³ /min
Seal kit:	RB700101

NOTES

Installation torque: 45 - 50 Nm

OPTIONS

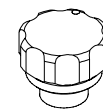

Standard

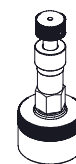

Push and pull manual override

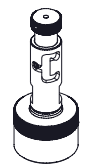

Push pull and twist manual override

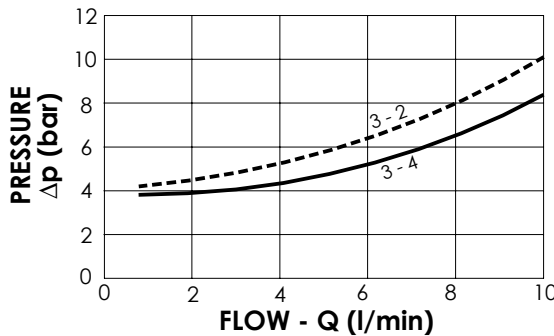

ORDERING CODES

Quick code	Description	Options	
CE000083	CEES-010-SEFN-53-S08-N210	Standard	
CE000097	CEES-010-SEFL-53-S08-N210	Push and pull manual override	
CE000185	CEES-010-SEFG-53-S08-N210	Push pull and twist manual override	

SOLENOID OPERATED CARTRIDGE

CEES-010-SEFN

**DIRECT OPERATED
SPOOL TYPE**

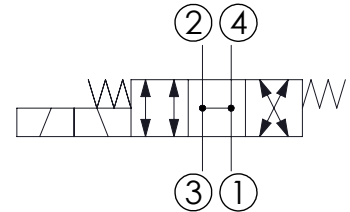
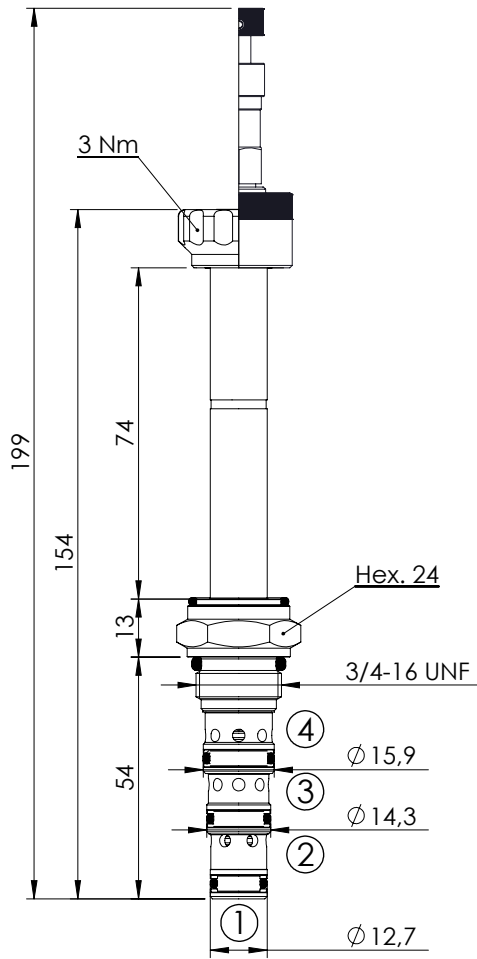

SPECIFICATIONS

Max. operating pressure:	210 bar
Rated flow:	10 l/min
Cavity:	SAE-08-4N
Weight:	0,18 kg
Min. voltage required:	90% of nominal
Coil type:	M7 type
Leakage:	120cm ³ /min
Seal kit:	RB700101

NOTES

Installation torque: 45 - 50 Nm

OPTIONS

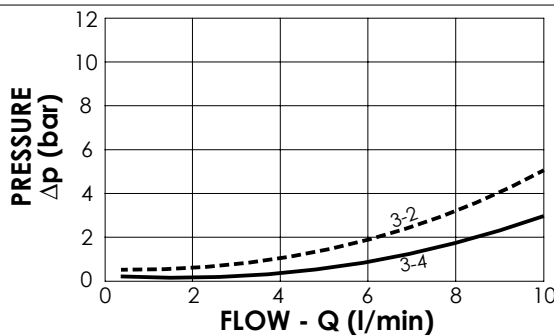
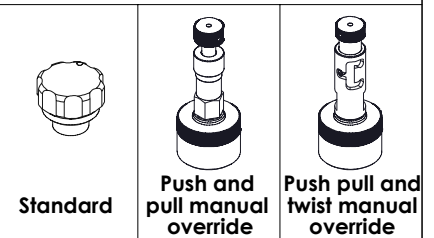

ORDERING CODES

Quick code	Description	Options	
CE000018	CEES-010-SEFN-54-S08-N210	Standard	
CE000099	CEES-010-SEFL-54-S08-N210	Push and pull manual override	
CE000188	CEES-010-SEFG-54-S08-N210	Push pull and twist manual override	



ATLANTIC
Fluid Tech

SECTION 16

Proportional
Cartridges



1800-OILSOL
1800-645765

<https://oilsolutions.com.au/>

sales@oilsolutions.com.au

SECTION 16



PROPORTIONAL CARTRIDGES

Hydraulic scheme	Valve description	Valve type	Rated flow (l/min)	Max. pressure (bar)	Installation	Main port size or cavity type	Page
	CECS-005-PRPN	Proportional, direct operated, pressure reducing	5	50	DT04-2P	VP000371	16.01.010
	CECT-080-PRPS	Proportional, pilot operated, reducing and relieving	80	250	Cartridge	SAE-10-3N	16.02.020
	CEBD-005-PLPS	Proportional, poppet type relief	5	350	Cartridge	SAE-08-2N	16.03.030
	CEBT-120-PLPS	Proportional, pilot operated, relieving	120	350	Cartridge	SAE-10-2N	16.04.040
	CEBT-120-PMPS	Proportional, pilot operated, relieving, for fan drive	120	350	Cartridge	SAE-10-2N	16.04.050
	CEBT-300-PLPS	Proportional, pilot operated, relieving	300	350	Cartridge	SAE-16-2N	16.04.060
	CEBT-500-PLPS	Proportional, pilot operated, relieving	500	350	Cartridge	SAE-20-2N	16.04.070
	CECS-020-FSPS	Proportional, non compensated, flow regulator	20	210	Cartridge	SAE-10-3N	16.05.080
	CECS-030-FSPS	Proportional, non compensated, flow regulator	30	210	Cartridge	SAE-10-3N	16.05.080
	CECS-040-FSPS	Proportional, non compensated, flow regulator	40	210	Cartridge	SAE-10-3N	16.05.080
	CECS-140-FRPV	Proportional, direct operated, flow regulator	140	320	Cartridge	SAE-16-3N	16.06.090
	CEBP-070-NCPN	Proportional, non compensated, normally closed	30	350	Cartridge	VP000057	10.07.100
	CEBS-020-PEPS	Proportional, normally closed	20	210	Cartridge	SAE-08-2N	10.08.110
	ELPC-030-SCCB	Proportional electronic controller	-	-	DIN 43650	-	10.09.120

SOLENOID OPERATED CARTRIDGE

CECS-005-PRPN

**PROPORTIONAL VALVES
DIRECT OPERATED
PRESSURE REDUCING**

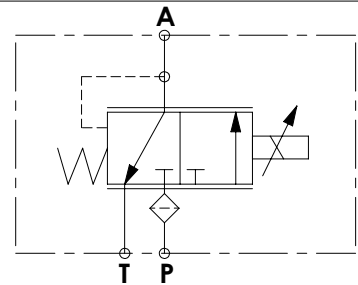
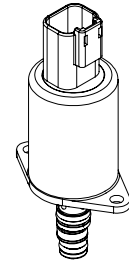
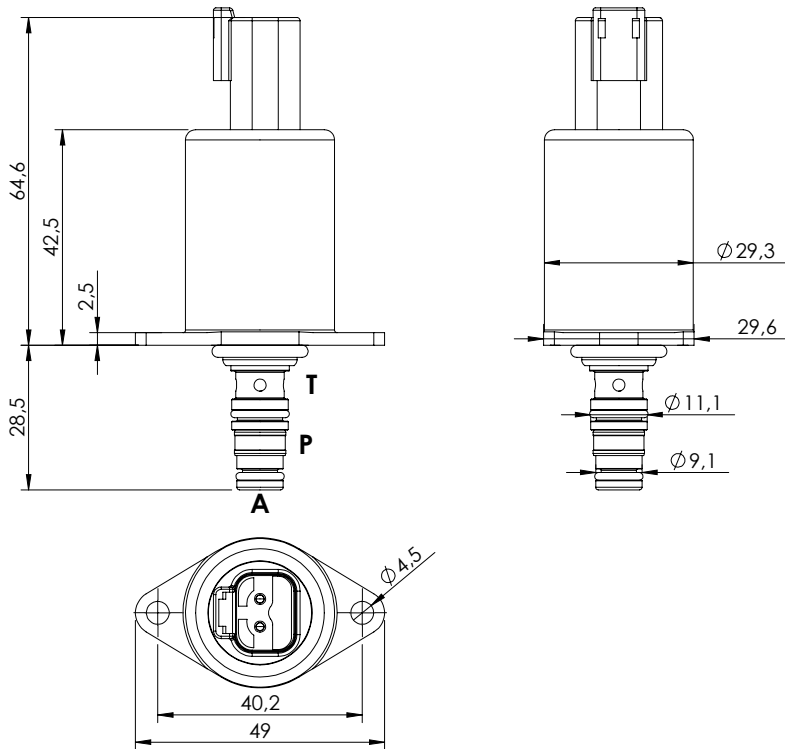

SPECIFICATIONS

Max. P pressure:	50 bar
Max. T pressure:	30 bar
Rated flow:	5 l/min
Cavity:	VP000371
Weight:	0,200 kg
Connector type:	Deutsch DT04-2P
Internal leakage:	15 cc/min (@ 25 bar, 46 cst)
Protection class:	Up to IP6K6 / IPX9K
PWM range recommended:	100 Hz
Filter on P port:	125 µm
Mounting screw:	2 x M4x10 class 8.8
Mounting screw torque:	3.5 Nm
Mounting screw not included	
Seal kit:	RC700371

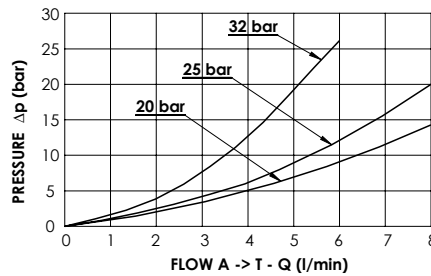
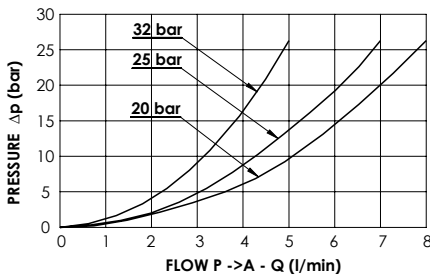
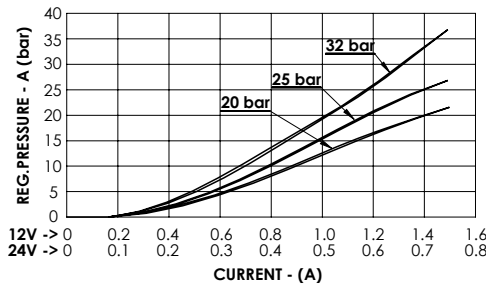

ORDERING CODES

Quick code	Description	Regulated pressure range (bar)	Voltage (V)	Current (mA)	Resistance (Ω) ± 5%	Hysteresis (bar) pA
CE000850	CECS-005-PRPN-95-371-N020-12DT	0-20	12	1500	4.72	< 0.4
CE000851	CECS-005-PRPN-95-371-N020-24DT	0-20	24	750	20.8	< 0.4
CE000852	CECS-005-PRPN-95-371-N025-12DT	0-25	12	1500	4.72	< 0.5
CE000853	CECS-005-PRPN-95-371-N025-24DT	0-25	24	750	20.8	< 0.5
CE000893	CECS-005-PRPN-95-371-N032-12DT	0-32	12	1500	4.72	< 0.7
CE000862	CECS-005-PRPN-95-371-N032-24DT	0-32	24	750	20.8	< 0.7

SOLENOID OPERATED CARTRIDGE

CECT-080-PRPS

**PROPORTIONAL VALVES
PILOTED OPERATED PRESSURE
REDUCING AND RELIEVING**

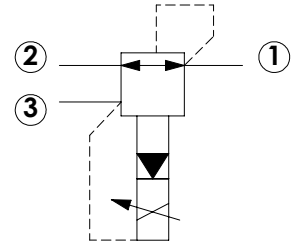
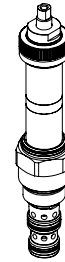
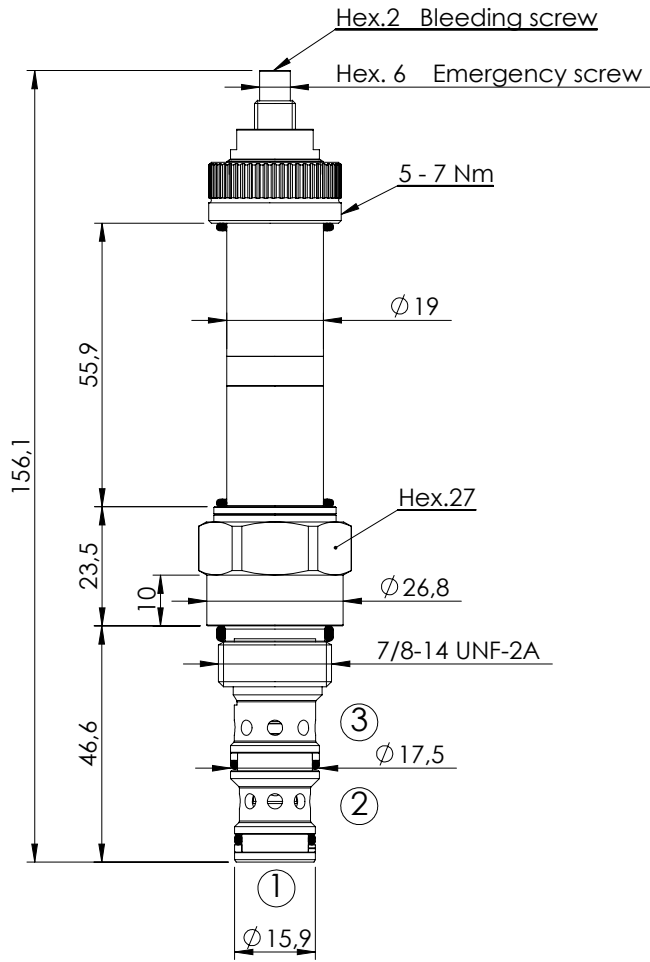

SPECIFICATIONS

Max. operating pressure:	250 bar
Rated flow:	80 l/min
Cavity:	SAE-10-3N
Weight:	0,22 kg
Coil type:	M15 type
Installation torque:	55 - 62 Nm
PWM range recommended:	120-150 Hz
Seal kit:	RA100092

NOTES

Bleed air before use

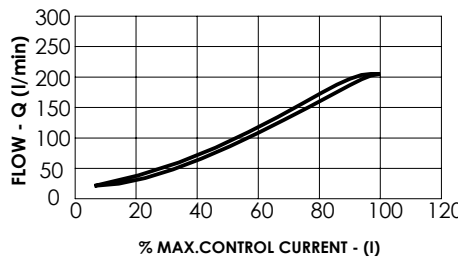
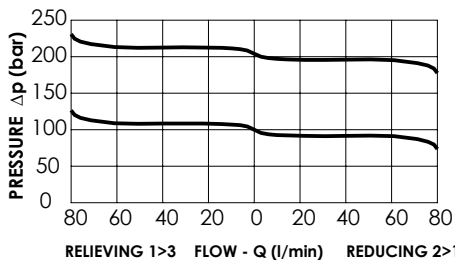

ORDERING CODES

Quick code	Description	Regulated pressure range (bar)	Threshold current (with 12VDC coil)	Max control current (with 12V DC coil)	Override
CE000122	CECT-080-PRPS-96-S10-V210	20-220	200 mA (+/-7%)	1700 mA (+/-7%)	Screw style

SOLENOID OPERATED CARTRIDGE

CEBD-005-PLPS

**PROPORTIONAL VALVES
POPPET TYPE RELIEF**

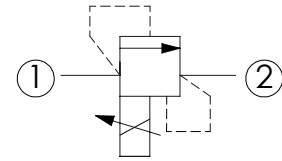
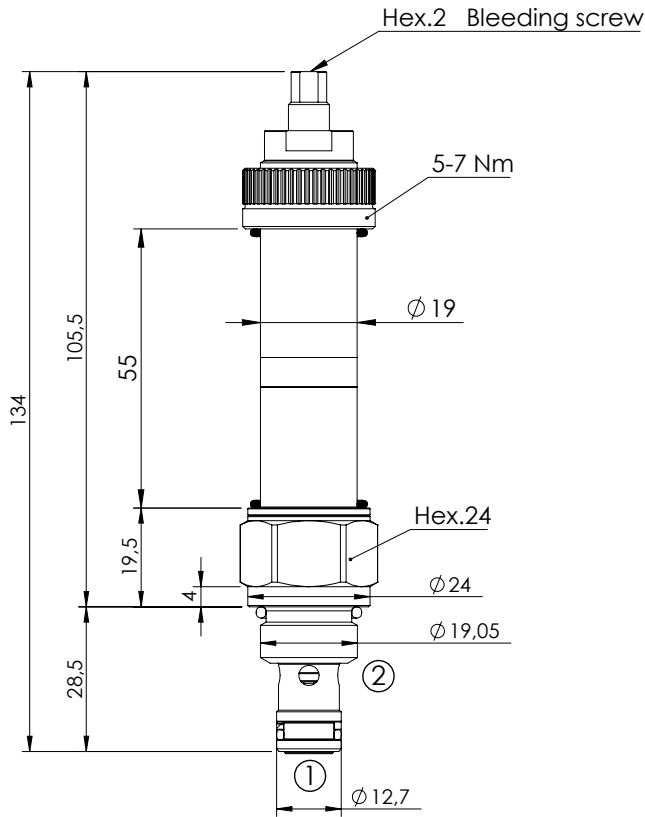

SPECIFICATIONS

Max. operating pressure:	350 bar
Rated flow:	5 l/min
Cavity:	SAE-08-2N
Weight:	0,16 kg
Coil type:	M15 type
PWM range recommended:	150-180 Hz
Installation torque:	45 - 50 Nm
Seal kit:	RA100081

NOTES

Bleed air before use

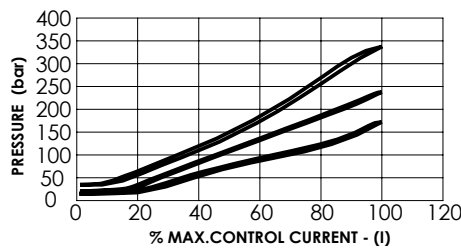
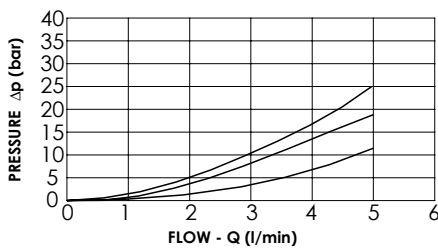

ORDERING CODES

Quick code	Description	Setting range (bar)	Threshold current (with 12VDC coil)	Max control current (with 12V DC coil)	Override
CE000910	CEBD-005-PLPS-92-S08-V350	25-340	250 mA (+/-7%)	1800 mA (+/-7%)	Screw style
CE000911	CEBD-005-PLPS-92-S08-V200	17-250	200 mA (+/-7%)	1800 mA (+/-7%)	Screw style
CE000912	CEBD-005-PLPS-92-S08-V100	9-160	200 mA (+/-7%)	1800 mA (+/-7%)	Screw style

SOLENOID OPERATED CARTRIDGE

CEBT-120-PLPS

**PROPORTIONAL VALVES
PILOTED RELIEF
SPOOL TYPE**

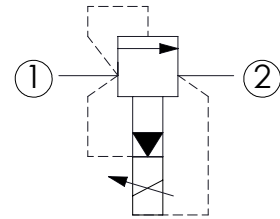
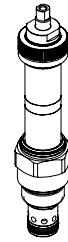
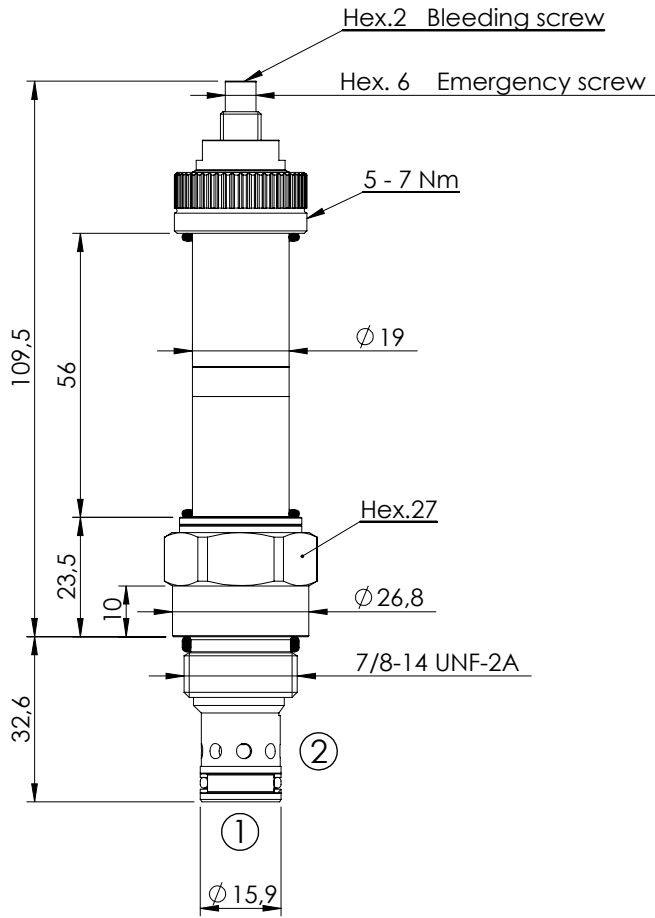

SPECIFICATIONS

Max. operating pressure:	350 bar
Rated flow:	120 l/min
Cavity:	SAE-10-2N
Weight:	0,2 kg
Coil type:	M15 type
Max. int. leakage:	200 cm ³ /min (@46 cst)
Installation torque:	55 - 62 Nm
PWM range recommended:	150-180 Hz
Seal kit:	RB100082

NOTES

Bleed air before use

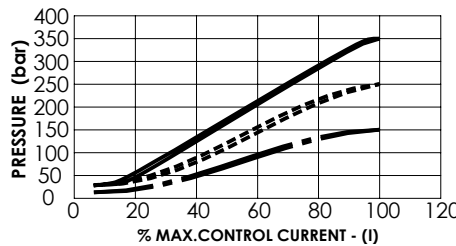
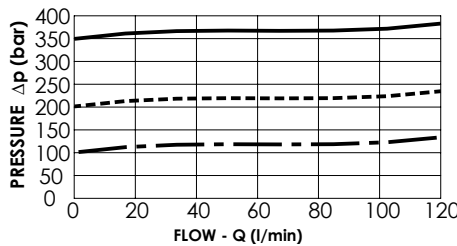

CE000119 1>2 ——— CE000120 1>2 - - - - - CE000121 1>2 — - - - -

ORDERING CODES

Quick code	Description	Setting range (bar)	Threshold current (with 12VDC coil)	Max control current (with 12V DC coil)	Override
CE000119	CEBT-120-PLPS-91-S10-V350	30-350	200 mA (+/-7%)	1600 mA (+/-7%)	Screw style
CE000120	CEBT-120-PLPS-91-S10-V200	20-220	200 mA (+/-7%)	1700 mA (+/-7%)	Screw style
CE000121	CEBT-120-PLPS-91-S10-V100	15-90	200 mA (+/-7%)	1700 mA (+/-7%)	Screw style

SOLENOID OPERATED CARTRIDGE

CEBT-120-PMPS

**PROPORTIONAL VALVES
PILOTED RELIEF
SPOOL TYPE FOR FAN DRIVE**

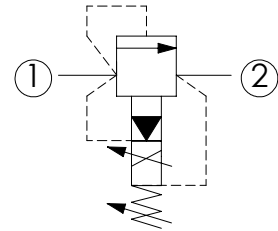
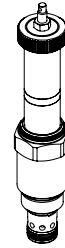
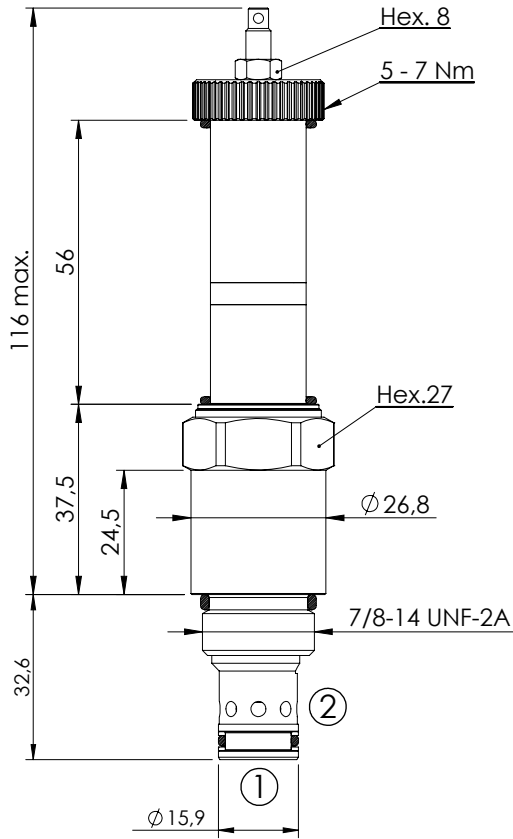

SPECIFICATIONS

Max. operating pressure:	350 bar
Rated flow:	120 l/min
Cavity:	SAE-10-2N
Weight:	0,21 kg
Coil type:	M15 type
Max. int. leakage:	200 cm ³ /min (@46 cst)
Installation torque:	55 - 62 Nm
PWM range recommended:	150-180 Hz
Seal kit:	RB100082

NOTES

Pressure decreasing with current increasing.
Maximum pressure value can be adjusted manually within a range.

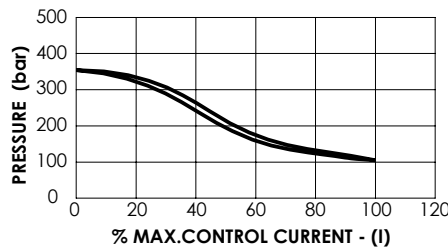
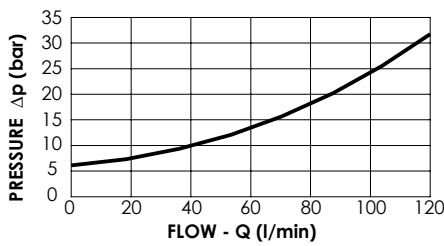

ORDERING CODES

Quick code	Description	Minimum pressure (bar)	Max. pressure setting range (bar)	Standard setting (bar)	Threshold current (with 12VDC coil)	Max control current (with 12V DC coil)
CE000890	CEBT-120-PMPS-91-S10-V350	7	100-350	210	200 mA (+/-7%)	1600 mA (+/-7%)

SOLENOID OPERATED CARTRIDGE

CEBT-300-PLPS

**PROPORTIONAL VALVES
PILOTED RELIEF
SPOOL TYPE**

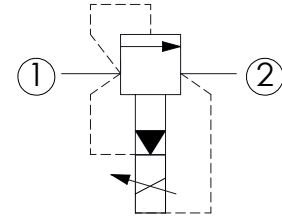
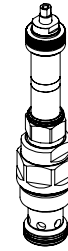
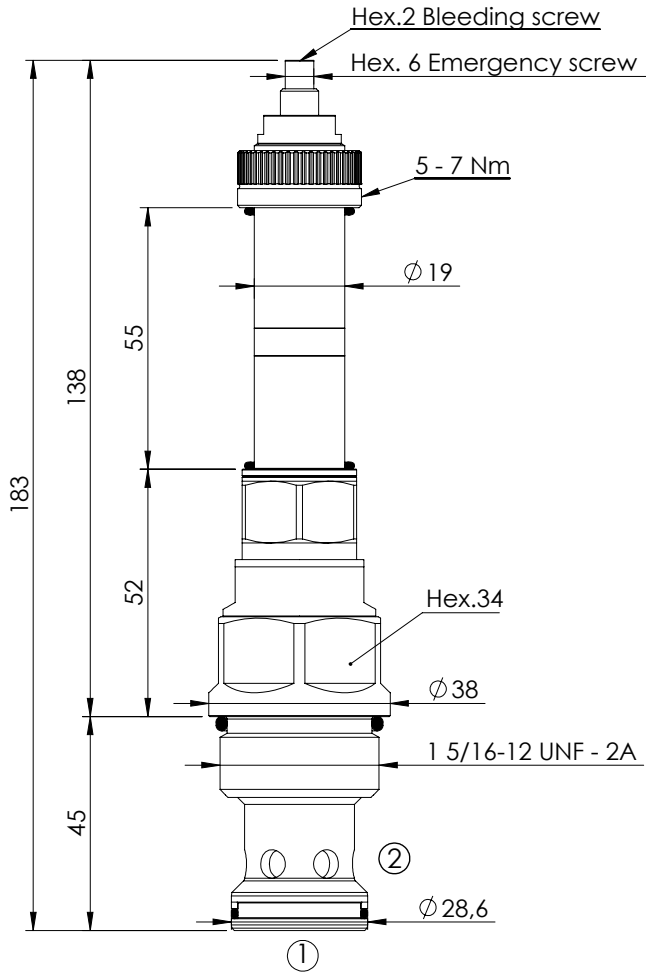

SPECIFICATIONS

Max. operating pressure:	350 bar
Rated flow:	300 l/min
Cavity:	SAE-16-2N
Weight:	0,5 kg
Coil type:	M15 type
Max. int. leakage:	200 cm ³ /min (@46 cst)
Installation torque:	118 - 132 Nm
PWM range recommended:	150-180 Hz
Seal kit:	RA100084

NOTES

Bleed air before use

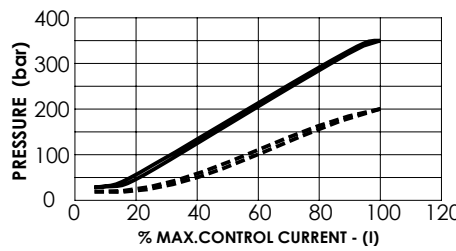
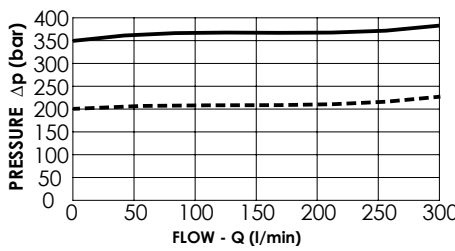

CE000880 1>2 ————— CE000895 1>2 - - - - -

ORDERING CODES

Quick code	Description	Proportional setting range (bar)	Threshold current (with 12VDC coil)	Max control current (with 12V DC coil)	Override
CE000880	CEBT-300-PLPS-91-S16-V350	30-350	200 mA (+/-7%)	1600 mA (+/-7%)	Screw style
CE000895	CEBT-300-PLPS-91-S16-V200	20-200	200 mA (+/-7%)	1700 mA (+/-7%)	Screw style

SOLENOID OPERATED CARTRIDGE

CEBT-500-PLPS

**PROPORTIONAL VALVES
PILOTED RELIEF
SPOOL TYPE**

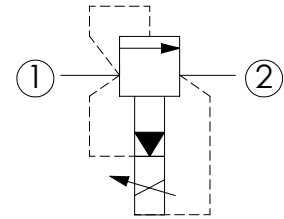
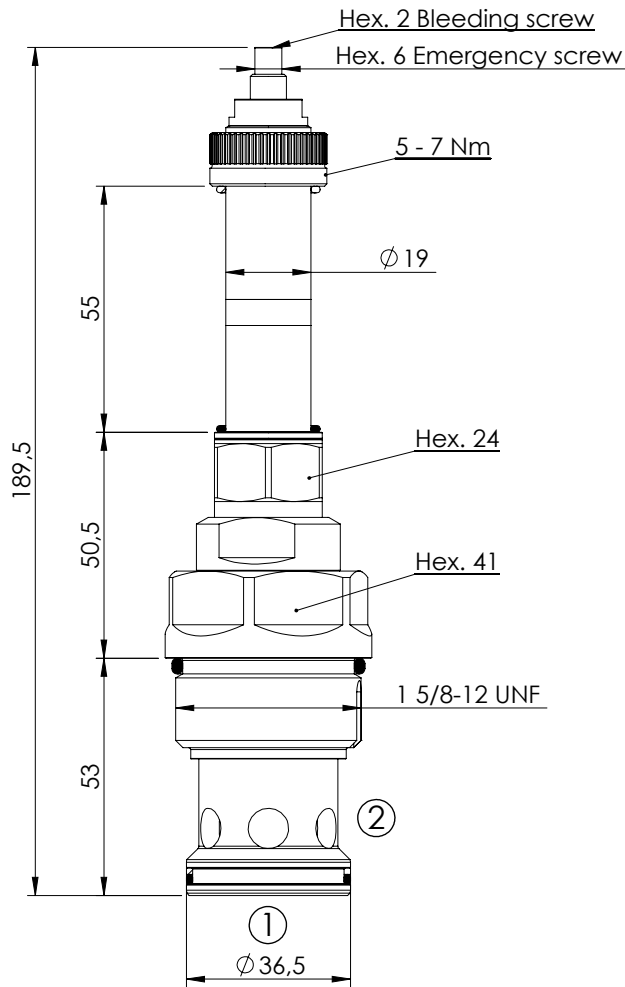

SPECIFICATIONS

Max. operating pressure:	350 bar
Rated flow:	500 l/min
Cavity:	SAE-20-2N
Weight:	0,7 kg
Coil type:	M5 type
Max. int. leakage:	200 cm ³ /min (@46 cst)
Installation torque:	230 - 250 Nm
PWM range recommended:	150-180 Hz

Seal kit: RA100085

NOTES

Bleed air before use

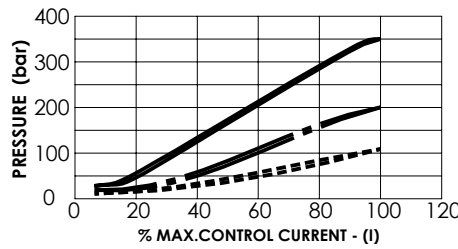
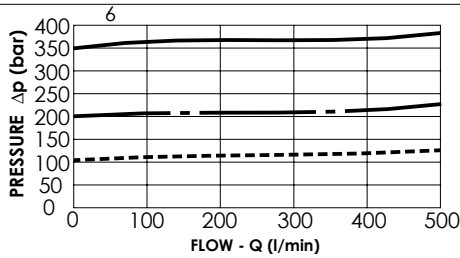

CE000770 1>2 ———
 CE000771 1>2 - - - -
 CE000772 1>2 ·····

ORDERING CODES

Quick code	Description	Setting range (bar)	Threshold current (with 12VDC coil)	Max control current (with 12V DC coil)	Override
CE000770	CEBT-500-PLPS-91-S20-V350	30-350	200 mA (+/-7%)	1600 mA (+/-7%)	Screw style
CE000771	CEBT-500-PLPS-91-S20-V200	20-220	200 mA (+/-7%)	1700 mA (+/-7%)	Screw style
CE000772	CEBT-500-PLPS-91-S20-V100	15-90	200 mA (+/-7%)	1700 mA (+/-7%)	Screw style

SOLENOID OPERATED CARTRIDGE

CECS-040-FSPS

**PROPORTIONAL VALVES
NON COMPENSATED
FLOW REGULATOR**

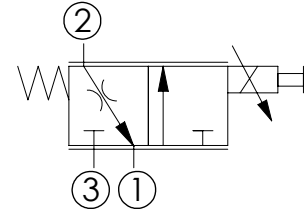
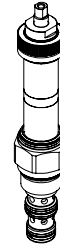
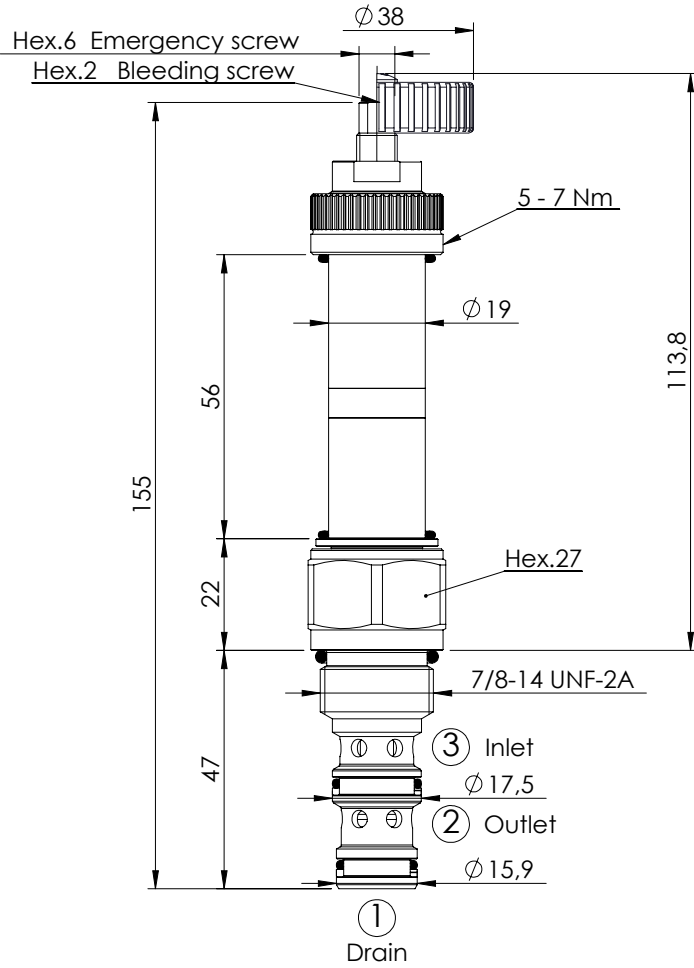

SPECIFICATIONS

Max. operating pressure:	210 bar
Rated flow:	40 l/min
Cavity:	SAE-10-3N
Weight:	0,22 kg
Coil type:	M15 type
Max. int. leakage:	150 cm ³ /min (@46 cSt)
Installation torque:	55 - 62 Nm
Recommended PWM range:	150-180 Hz
Seal kit:	RA100092

NOTES

Bleed air before use

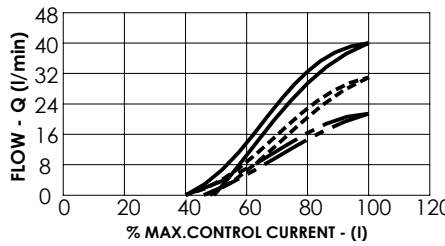
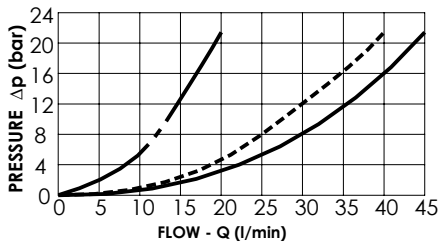

CE000111 3>2 ——— CE000112 3>2 - - - - - CE000113 3>2 — - - - -

ORDERING CODES

Quick code	Description	Rated flow (l/min)	Threshold current (with 12VDC coil)	Max control current (with 12V DC coil)	Override
CE000111	CECS-040-FSPS-85-S10-V210	40	800 mA (+/-7%)	1600 mA (+/-7%)	Screw style
CE000112	CECS-030-FSPS-85-S10-V210	30	700 mA (+/-7%)	1500 mA (+/-7%)	Screw style
CE000113	CECS-020-FSPS-85-S10-V210	20	700 mA (+/-7%)	2400 mA (+/-7%)	Screw style
CE000960	CECS-040-FSPV-85-S10-V210	40	800 mA (+/-7%)	1600 mA (+/-7%)	Handknob style
CE000906	CECS-030-FSPV-85-S10-V210	30	700 mA (+/-7%)	1500 mA (+/-7%)	Handknob style
CE000489	CECS-020-FSPV-85-S10-V210	20	700 mA (+/-7%)	2400 mA (+/-7%)	Handknob style

PROPORTIONAL CARTRIDGE

CECS-140-FRPM

PROPORTIONAL VALVES
FLOW REGULATOR
3 WAYS COMBINATION

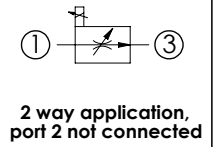
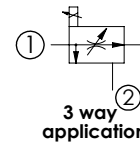
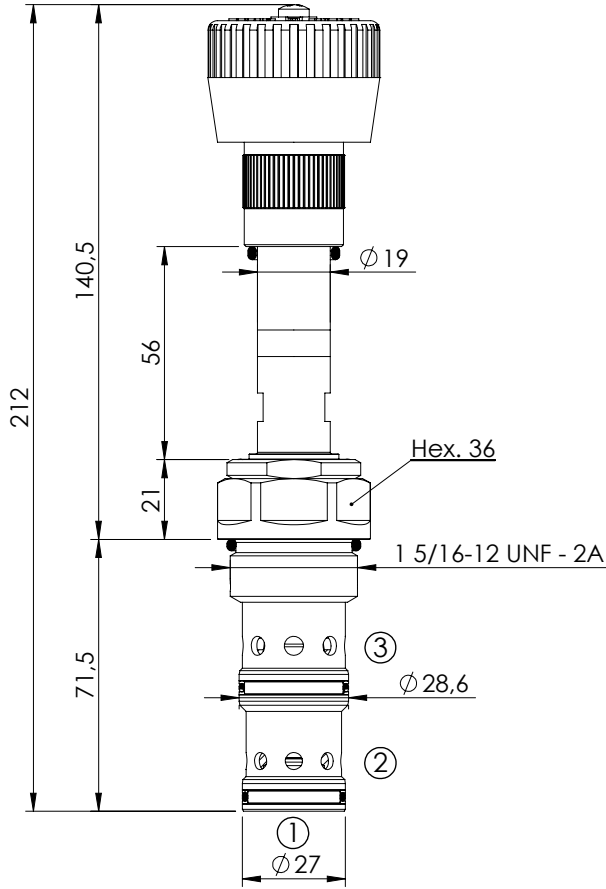

SPECIFICATIONS

Max. operating pressure:	320 bar
Maximum flow (in inlet port ①):	140 l/min
Max. flow ① to ③:	100 l/min (regulated)
Pressure differential (① to ③):	7 - 11 bar
Hysteresis (ramp up and down):	1,5 - 3 %
Coil type:	M15
Voltage:	12- 24 V dc
Max current (12 V dc):	1800 mA
Max current (24 V dc):	1200 mA
Coil resistance (12 V dc):	3,3-5,8 Ω
Coil resistance (24 V dc):	7,2-13 Ω
Weight:	0,6 kg
Cavity:	SAE-16-3N
Installation torque:	130 -145 Nm
Surface protection proportional solenoid:	Coating DIN 50962 Fe8//ZiNi with passivation
Seal kit:	RB100094

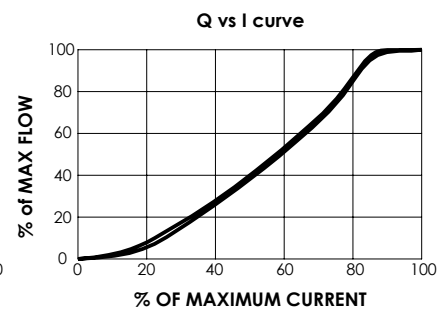
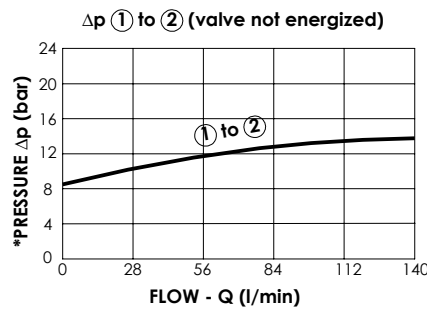
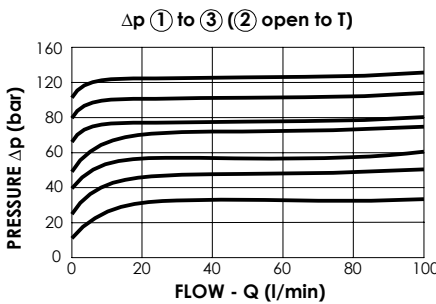

ORDERING CODES

Quick code	Description	Regulated flow range (l/min)	Adjustment type
CE000831	CECS-140-FRPM-15-S16-V320	0 - 15	Handknob
CE000832	CECS-140-FRPM-25-S16-V320	0 - 25	Handknob
CE000833	CECS-140-FRPM-40-S16-V320	0 - 40	Handknob
CE000834	CECS-140-FRPM-50-S16-V320	0 - 50	Handknob
CE000835	CECS-140-FRPM-65-S16-V320	0 - 65	Handknob
CE000836	CECS-140-FRPM-80-S16-V320	0 - 80	Handknob
CE001034	CECS-140-FRPM-100-S16-V320	0 - 100	Handknob

SOLENOID OPERATED CARTRIDGE

CEBS-020-PEPS

**PROPORTIONAL VALVE
NORMALLY CLOSED**

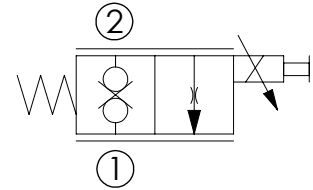
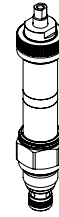
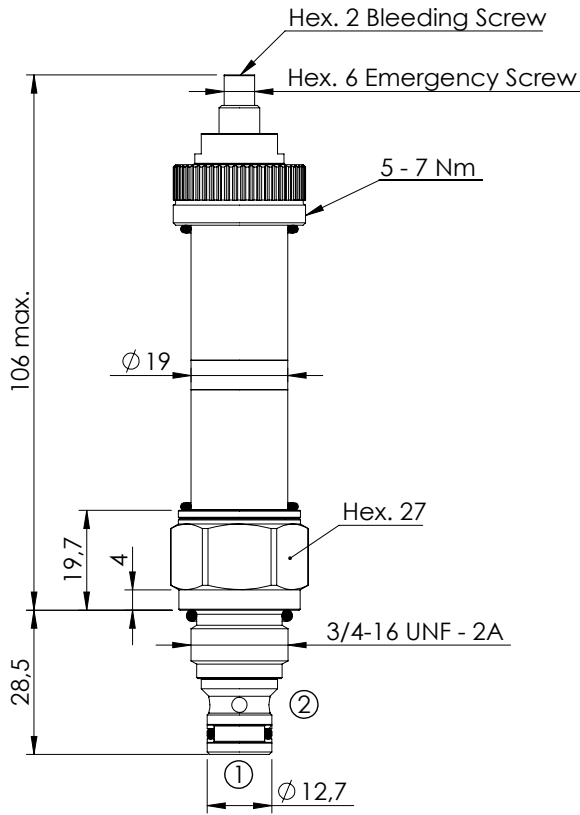

SPECIFICATIONS

Max. operating pressure:	210 bar
Rated flow:	20 l/min
Cavity:	SAE-08-2N
Weight:	0,15 kg
Coil type:	M15 type
Installation torque:	45 - 50 Nm
Recommended PWM range:	120-150 Hz
Seal kit:	RA100081

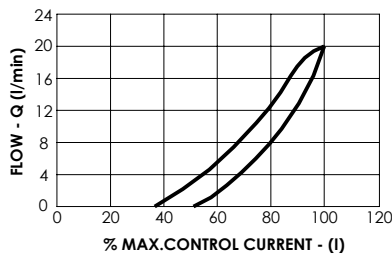
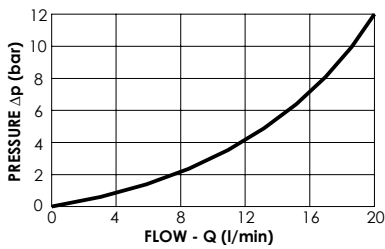

NOTES

Bleed air before use

ORDERING CODES

Quick code	Description	Rated flow (l/min)	Threshold current (with 12VDC coil)	Max control current (with 12V DC coil)	Override
CE000943	CEBS-020-PEPS-103-S08-V210	20	1000 mA (+/-7%)	2000 mA (+/-7%)	Screw style

PROPORTIONAL CARTRIDGE

CEBP-070-NCPN

PROPORTIONAL VALVE
NON COMPENSATED
NORMALLY CLOSED

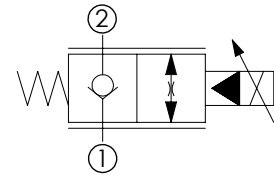
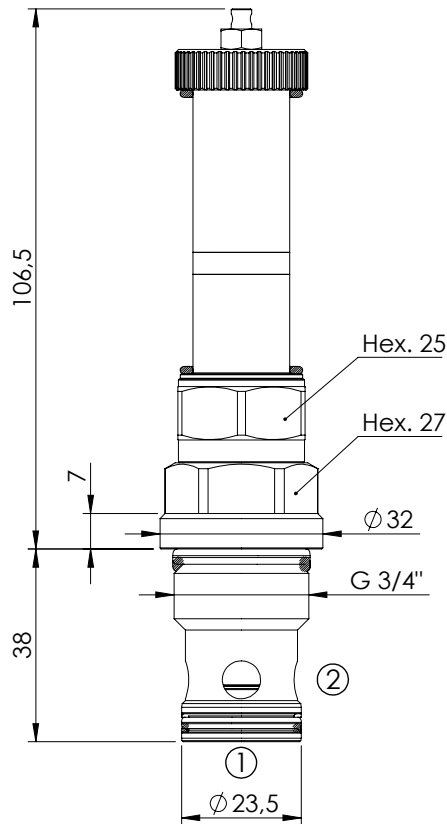

SPECIFICATIONS

Max. operating pressure:	350 bar
Rated flow:	70 l/min
Cavity:	VP000057
Weight:	0,26 kg
Coil type:	M15
Installation torque:	110 - 130 Nm
PWM range recommended:	150-180 Hz
Seal kit:	RD900057

NOTES

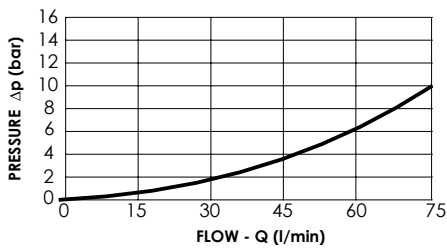

ORDERING CODES

Quick code	Description	Setting range (bar)	Threshold current (with 12VDC coil)	Max control current (with 12V DC coil)	Override
CE001026	CEBP-070-NCPN-112-057-N350	20	800 mA (+/-7%)	1800 mA (+/-7%)	Screw style

PROPORTIONAL VALVE CONTROLLER

ELPC-030-SCCB

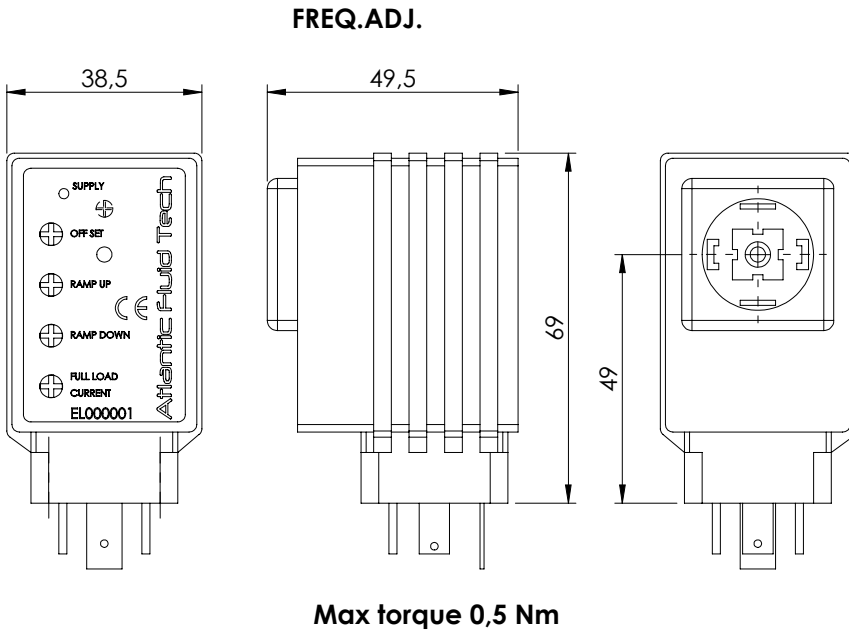
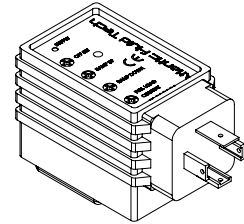

SPECIFICATIONS

- Supply voltage: 12 - 30 VDC**
Coil rating must be matched with supply voltage:
 $R_{coil} < (V_{supply} - 1.5V) / I_{max}$
- Control input signal options:**
5KΩ external potentiometer
(accepts 2KΩ to 10KΩ), or 0-10 VDC signal
(see connection diagram)
- Output current: up to 2A**
- Minimum current: 0 - 0,6 A**
- Max current deviation in temperature range: 3%**
- Ramp up / ramp down: 0,1 to 10 sec**
Ramp setting independent from current range
- PWM frequency: 100 - 500 Hz**
- Operating conditions: -20 TO +70°C**
0 to 85% relative humidity

CONNECTION EXAMPLE WITH JOYSTICK OR POTENTIOMETER

CONNECTION EXAMPLE WITH ANALOGIC SIGNAL

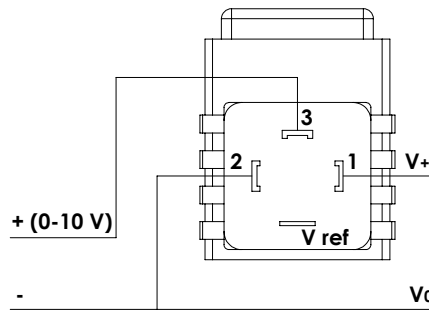
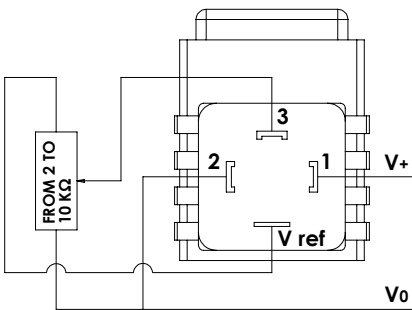

- Environmental protection: IP65**
with cover and seals installed
- Connector type: DIN 43650 - ISO 4400**

IMPORTANT

DO NOT REMOVE controller from solenoid when energized to avoid the risk of damaging it

SETTING INSTRUCTIONS

- SUPPLY:** led is on when current is supplied
- OFFSET:** to be used to set minimum current value (I min), turn clockwise to increase setting
- RAMP UP:** to be used to set the ramp time from minimum (I min) to maximum current value (I max)
- RAMP DOWN:** to be used to set the ramp time from maximum (I max) to minimum current value (I min)
- FULL LOAD CURRENT:** to be used to set maximum current value (I max), turn clockwise to increase setting
- FREQ. ADJ.:** this trimmer is inside the controller and is preset by factory, to be used to modify the PWM frequency

ORDERING CODES

Quick code	Description
EL000001	Proportional controller ELPC-030-SCCB



ATLANTIC
Fluid Tech

SECTION 17

**Diverter
Valves**



1800-OILSOL
1800-645765

<https://oilsolutions.com.au/>

sales@oilsolutions.com.au

SECTION 17



DIVERTER VALVES

Hydraulic scheme	Valve description	Valve type	Rated flow (l/min)	Max. pressure (bar)	Installation	Main port size or cavity type	Page
	ESCB-025	Three ports	25	250-310	In line	G 1/4"	17.01. 010
	ESCB-050	Three ports	50	250-310	In line	G 3/8"	17.01. 020
	ESCB-090	Three ports	90	250-310	In line	G 1/2"	17.01. 030
	ELFB-025	Six ports single	25	250-310	In line	G 1/4"	17.02. 040
	ESFB-025	Six ports single and bankable	25	250-310	In line/Flanged	G 1/4"	17.03. 050
	ESFB-050	Six ports single and bankable	50	250-350	In line/Flanged	G 3/8"	17.03. 060
	ESFB-100	Six ports single and bankable	90	250-350	In line/Flanged	G 1/2"	17.03. 070
	ELFB-400	Six ports single	400	210-420	In line	G 3/4" - 1" SAE 6000	17.04. 080
	ELHB-010	Eight ports, with detent	10	210	In line	G 1/4"	17.05. 090

FLOW DIVERTERS

ESCB-025

3 WAYS FLOW DIVERTERS



**	Circuit	Transit position
40		
41		
42		
43		

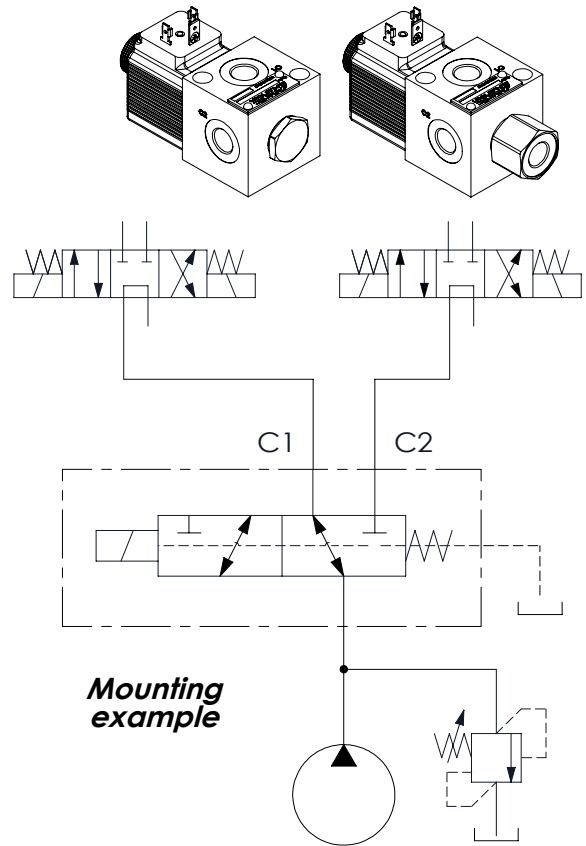

Technical data		
Rated flow	l/min	25
Operating pressure	with internal drain "N"	bar 250
	with external drain "E"	bar 310
Valve weight	Kg	0,80

OVERALL DIMENSIONS

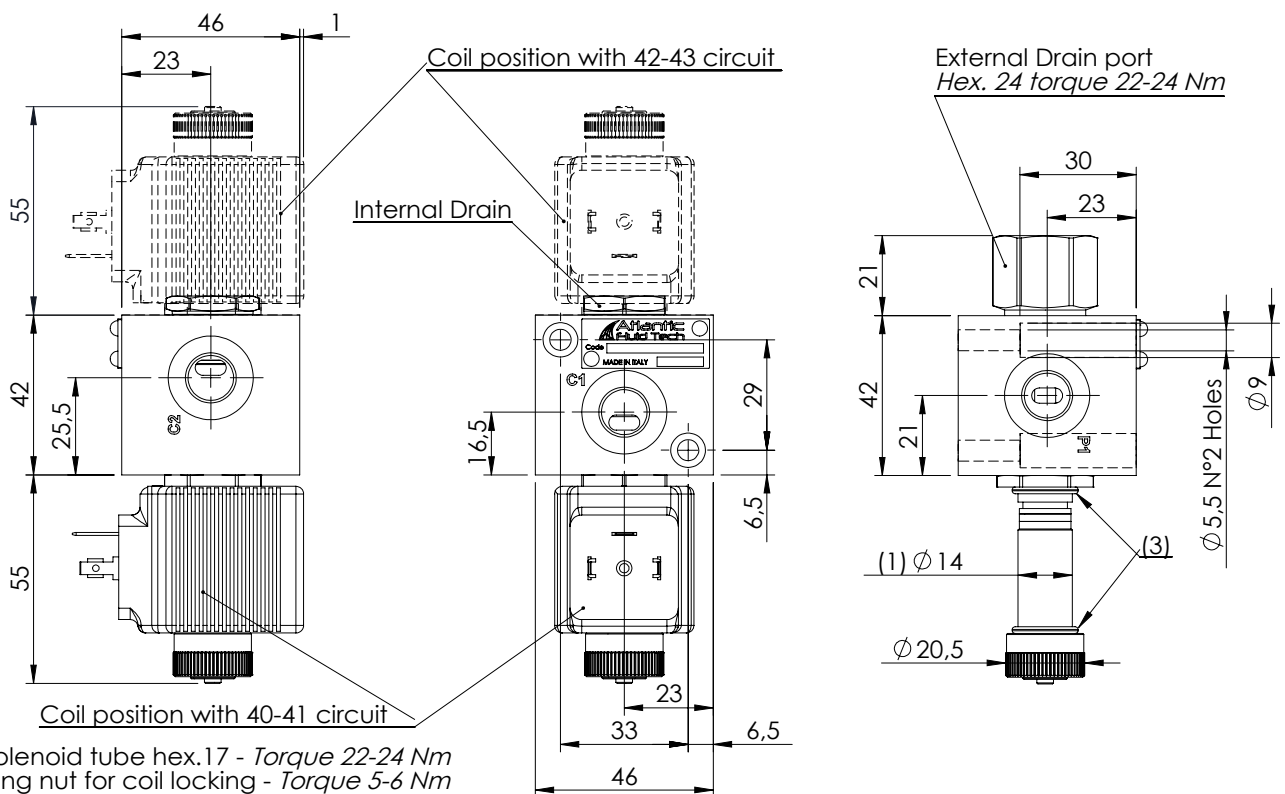

- (1) Solenoid tube hex.17 - Torque 22-24 Nm
- (2) Ring nut for coil locking - Torque 5-6 Nm
- (3) O-Ring $\phi 14,00 \times 1,78$

Characteristic curves

Measured with hydraulic fluid ISO-VG46 at 40° ± 5°C



Maximum performance

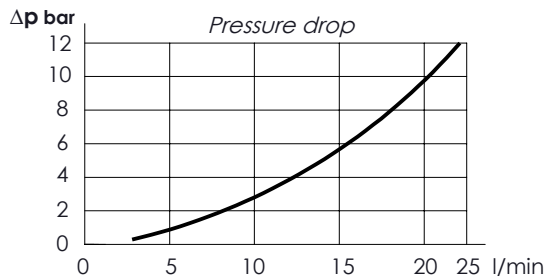
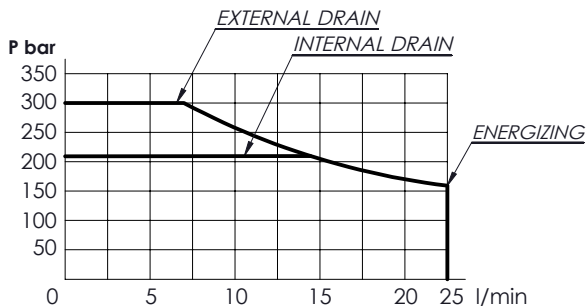

Internal leakage on C ports : MAX 15 cm³/min - Mineral oil with 32 cSt viscosity, at 40° C and 100 bar pressure

* OPERATED	Circuit
E Electric 	
N Hydraulic/pneumatic <p>(4) Hydraulic or pneumatic pilot connector: hex 30 mm - Torque 20-22 Nm With external drain Pilot Pressure Min. 5 bar With internal drain Pilot Pressure is 1/10 of the working pressure</p>	

* MANUAL OVERRIDE	
S Standard	
V Screw	
N Without manual override	

* DRAIN	Circuit
N Internal	
E External	

PORTS		
***	Main (C)	Drain (D)
G14	1/4" Gas	1/4" Gas
Other port sizes available		

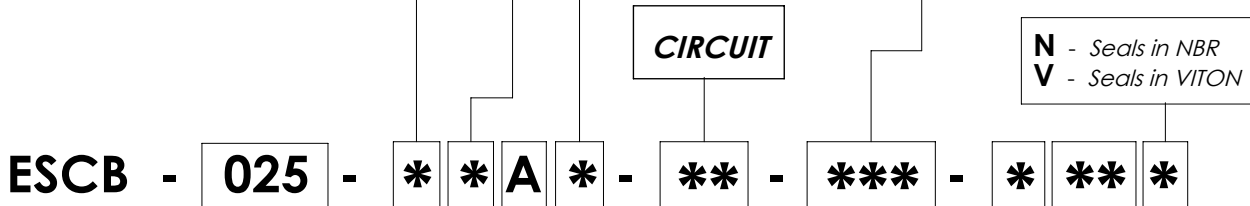

* Voltage (V)	Resistance (Ω) ± 7%	Power (W)	Current (A)
-	Without coil		
A	12 DC	5,53	26
B	24 DC	22,1	1,08
Other voltages available on request			

* COIL	Type	Protection class
-	Without coil	
HR	DIN 43650 - ISO 4400 Class H	M14 IP65
AJ	AMP JUNIOR Class H	M14 IP65
DT	DEUTSCH DT04-2P-L Class H	M14 IP69

FLOW DIVERTERS

ESCB-050

3 WAYS FLOW DIVERTERS



**	Circuit	Transit position
40		
41		
42		
43		

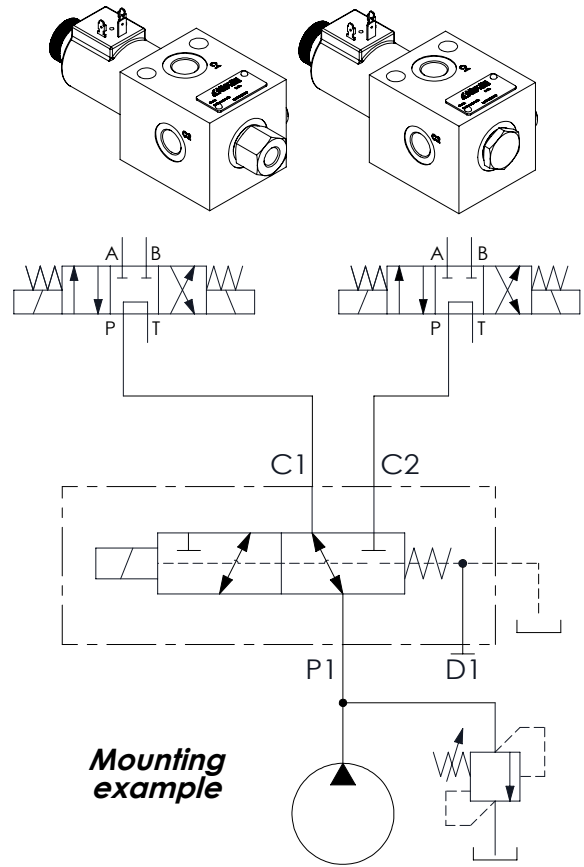

Technical data

Rated flow	l/min	50
Operating pressure	with internal drain "N"	bar 250
	with external drain "E"	bar 310
Valve weight	Kg	2,6

OVERALL DIMENSIONS

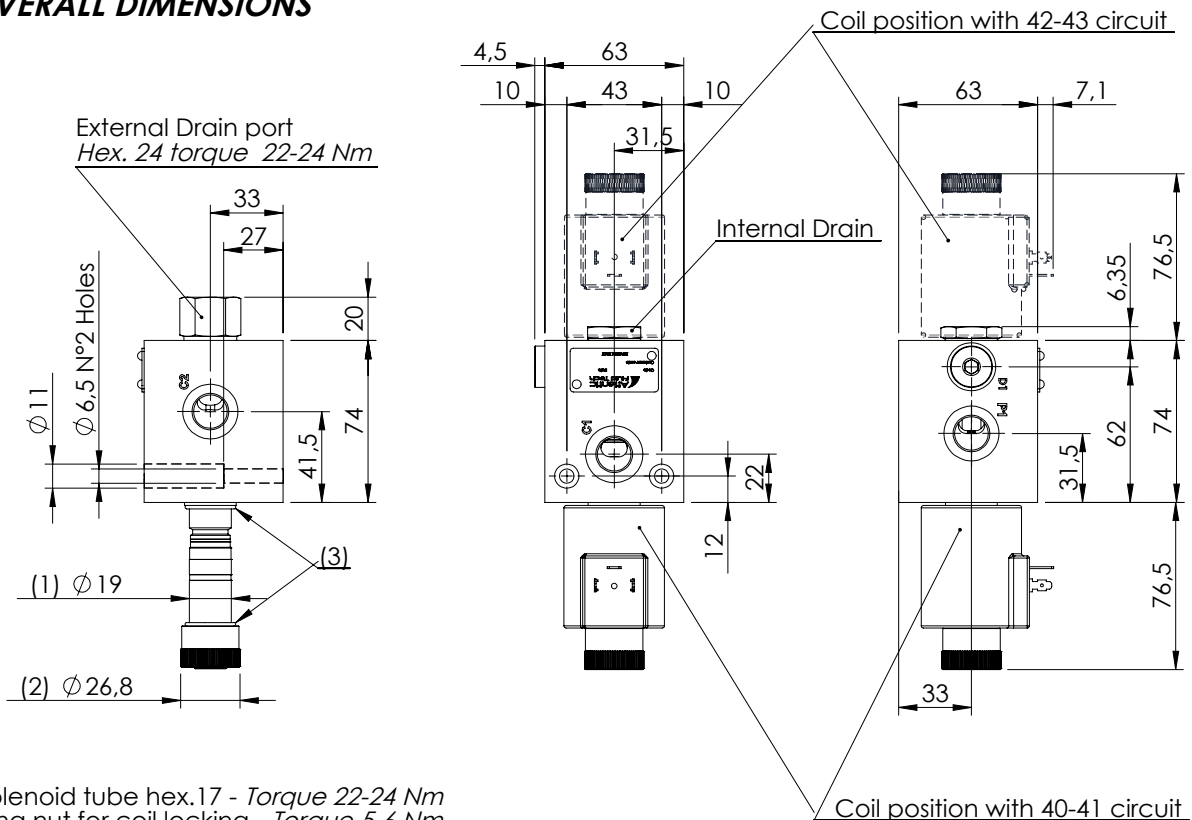

- (1) Solenoid tube hex.17 - Torque 22-24 Nm
- (2) Ring nut for coil locking - Torque 5-6 Nm
- (3) O-Ring Ø18,77 x1,78

Characteristic curves

Measured with hydraulic fluid ISO-VG46 at 40° ± 5°C

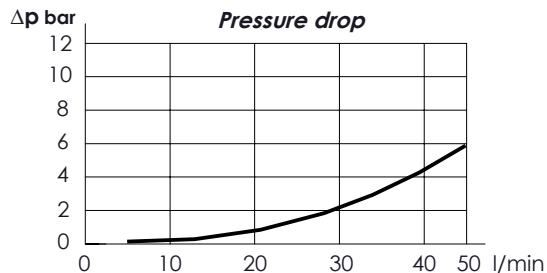
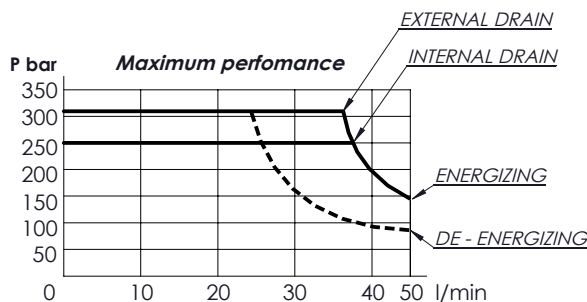

Internal leakage on C ports : MAX 25 cm³/min - Mineral oil with 32 cSt viscosity, at 40° C and 100 bar pressure

*	OPERATED	<i>Circuit</i>	*	MANUAL OVERRIDE	*	DRAIN	<i>Circuit</i>															
E	Electric 		S	Standard 	N	Internal 																
N	Hydraulic/pneumatic 		V	Screw 	E	External 																
	<p>(4) Hydraulic or pneumatic pilot connector: hex 30 mm - Torque 20-22 Nm</p> <p>With external drain Pilot Pressure Min. 5 bar</p> <p>With internal drain Pilot Pressure is 1/10 of the working pressure</p>		N	Without manual override	<table border="1"> <thead> <tr> <th colspan="3">PORTS</th> </tr> <tr> <th>***</th> <th>Main (C)</th> <th>Drain (D)</th> </tr> </thead> <tbody> <tr> <td>G38</td> <td>3/8" Gas</td> <td>1/4" Gas</td> </tr> <tr> <td></td> <td></td> <td></td> </tr> <tr> <td></td> <td></td> <td></td> </tr> </tbody> </table> <p>Other port sizes available</p>			PORTS			***	Main (C)	Drain (D)	G38	3/8" Gas	1/4" Gas						
PORTS																						
***	Main (C)	Drain (D)																				
G38	3/8" Gas	1/4" Gas																				

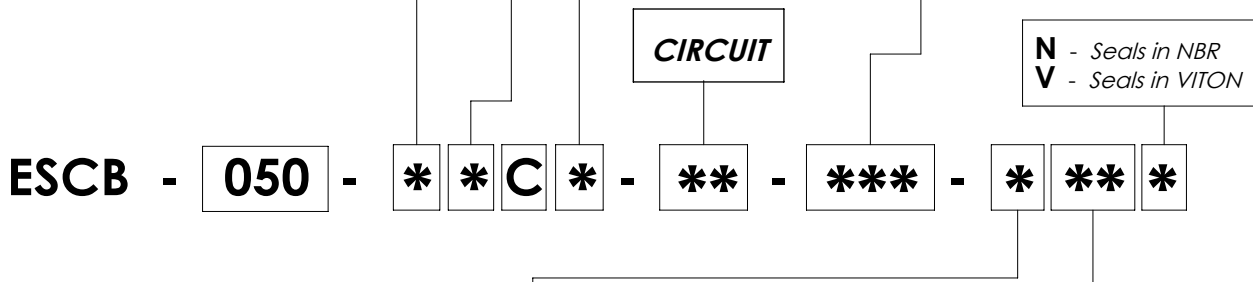

*	Voltage (V)	Resistance (Ω) ± 7%	Power (W)	Current (A)
-	<i>Without coil</i>			
A	12 DC	4,36	33	2,75
B	24 DC	17,45	33	1,37
<i>Other voltages available on request</i>				

*	COIL	Type	Protection class
-	<i>Without coil</i>		
HR	DIN 43650 - ISO 4400 Class H	M8	IP65
AJ	AMP JUNIOR Class H	M8	IP65
DT	DEUTSCH DT04-2P-L Class H	M8	IP69

**	Circuit	Transit position
40		
41		
42		
43		

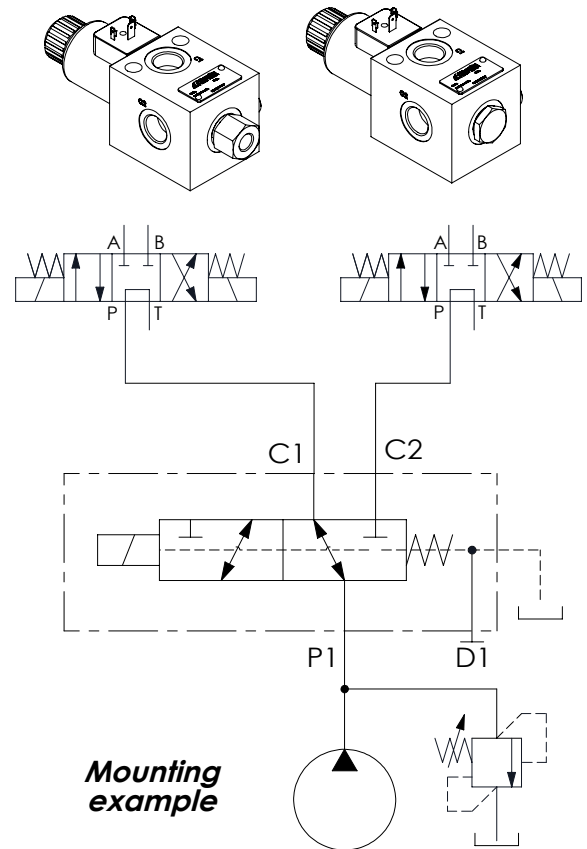

Technical data

Rated flow	l/min	90
Operating pressure	with internal drain "N"	bar 250
	with external drain "E"	bar 310
Valve weight	Kg	2,4

OVERALL DIMENSIONS

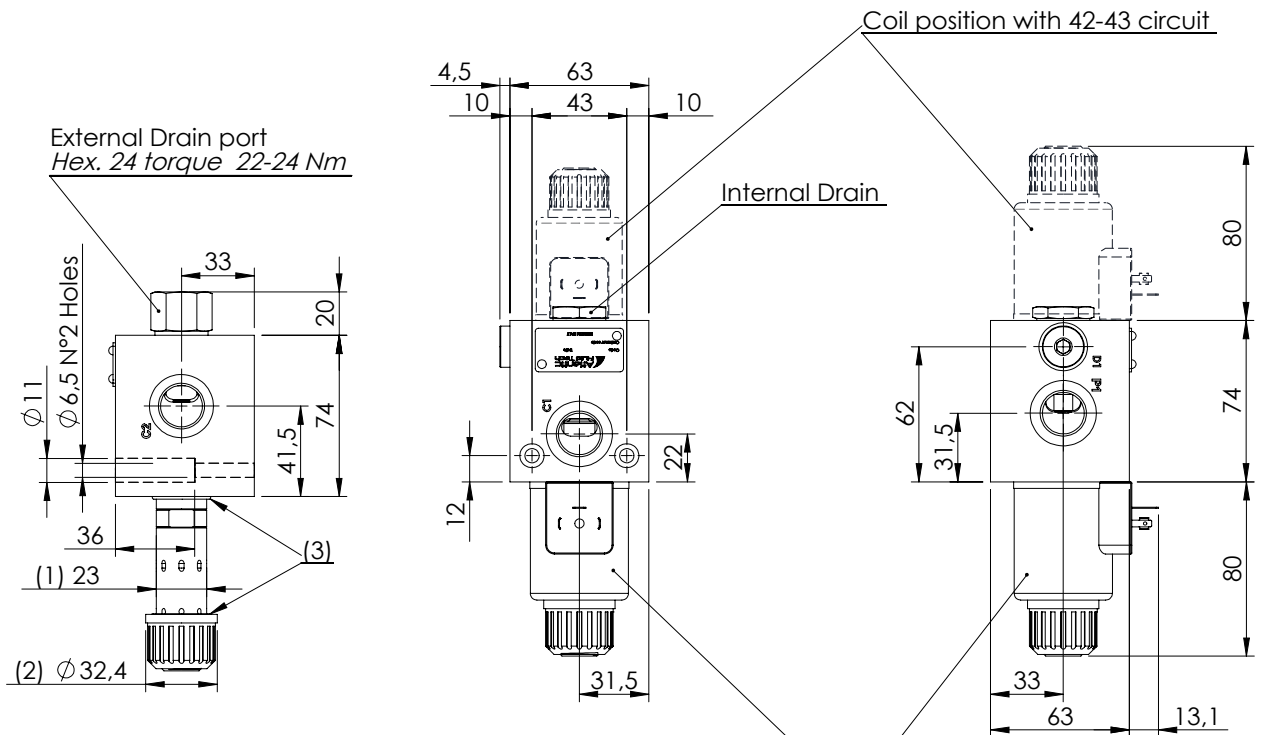

- (1) Solenoid tube hex.20 - Torque 18-22 Nm
- (2) Ring nut for coil locking - Torque 7-8 Nm
- (3) O-Ring $\varnothing 21,95 \times 1,78 - 22,22 \times 2,62$ (smaller one near manifold)

Characteristic curves

Measured with hydraulic fluid ISO-VG46 at 40° ± 5°C

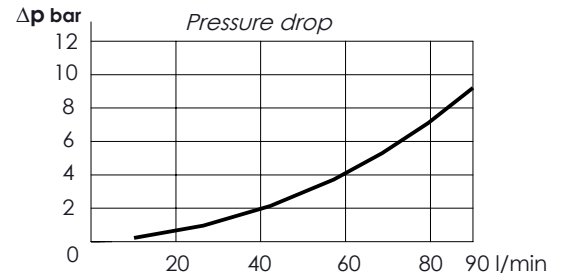
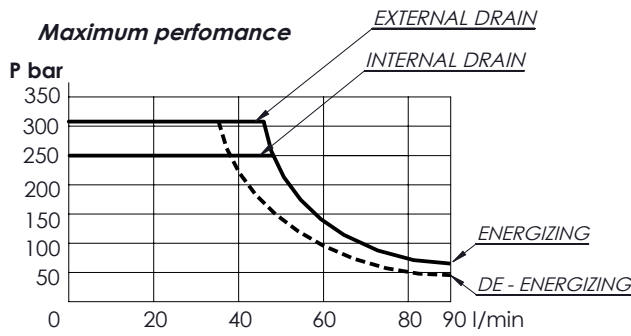

Internal leakage on C ports : MAX 25 cm³/min - Mineral oil with 32 cSt viscosity, at 40° C and 100 bar pressure

* OPERATED	Circuit	* MANUAL OVERRIDE	* DRAIN	Circuit															
E Electric 		S Standard 	N Internal 																
N Hydraulic/pneumatic 		V Screw 	E External 																
<p>(4) Hydraulic or pneumatic pilot connector: hex 30 mm - Torque 20-22 Nm</p> <p>With external drain Pilot Pressure Min. 5 bar</p> <p>With internal drain Pilot Pressure is 1/10 of the working pressure</p>		N Without manual override	<table border="1"> <thead> <tr> <th colspan="3">PORTS</th> </tr> <tr> <th>***</th> <th>Main (C)</th> <th>Drain (D)</th> </tr> </thead> <tbody> <tr> <td>G12</td> <td>1/2" Gas</td> <td>1/4" Gas</td> </tr> <tr> <td></td> <td></td> <td></td> </tr> <tr> <td></td> <td></td> <td></td> </tr> </tbody> </table> <p>Other port sizes available</p>		PORTS			***	Main (C)	Drain (D)	G12	1/2" Gas	1/4" Gas						
PORTS																			
***	Main (C)	Drain (D)																	
G12	1/2" Gas	1/4" Gas																	

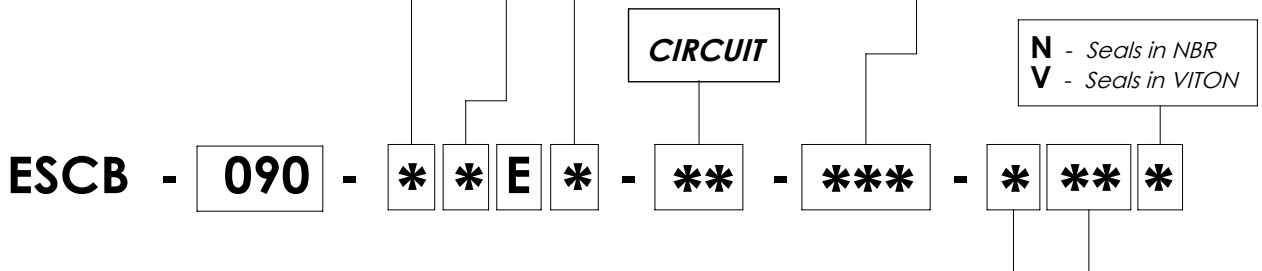

* Voltage (V)	Resistance (Ω) ± 7%	Power (W)	Current (A)
-	Without coil		
A 12 DC	3,27	44	3,67
B 24 DC	13,09	44	1,83
Other voltages available on request			

* COIL	Type	Protection class
-	Without coil	
HR DIN 43650 - ISO 4400 Class H	M11	IP65
AJ AMP JUNIOR Class H	M11	IP65
DT DEUTSCH DT04-2P-L Class H	M11	IP69

FLOW DIVERTERS

ELFB-025

**6 WAYS SINGLE IN LINE
FLOW DIVERTERS**



**	Circuit	Transit position
01		
02		
03		

*Only external drain

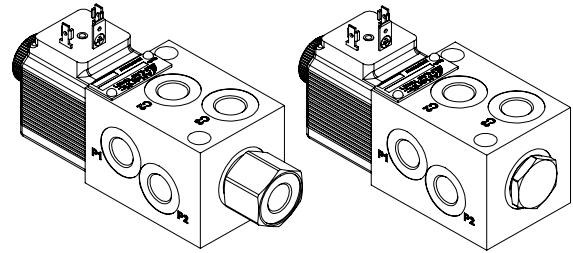

Mounting example

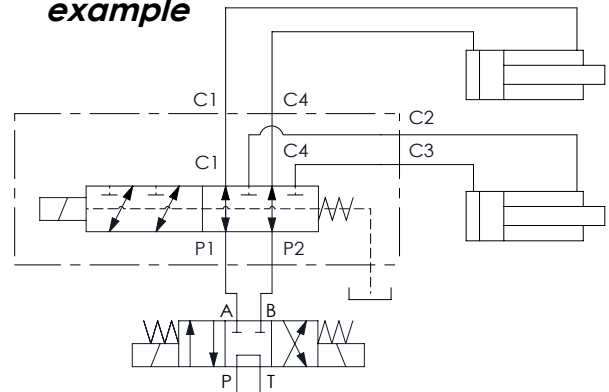

Technical data

Rated flow		l/min	25
Operating pressure	with internal drain "N"	bar	250
	with external drain "E"	bar	310
Valve weight		Kg	1,1

OVERALL DIMENSIONS

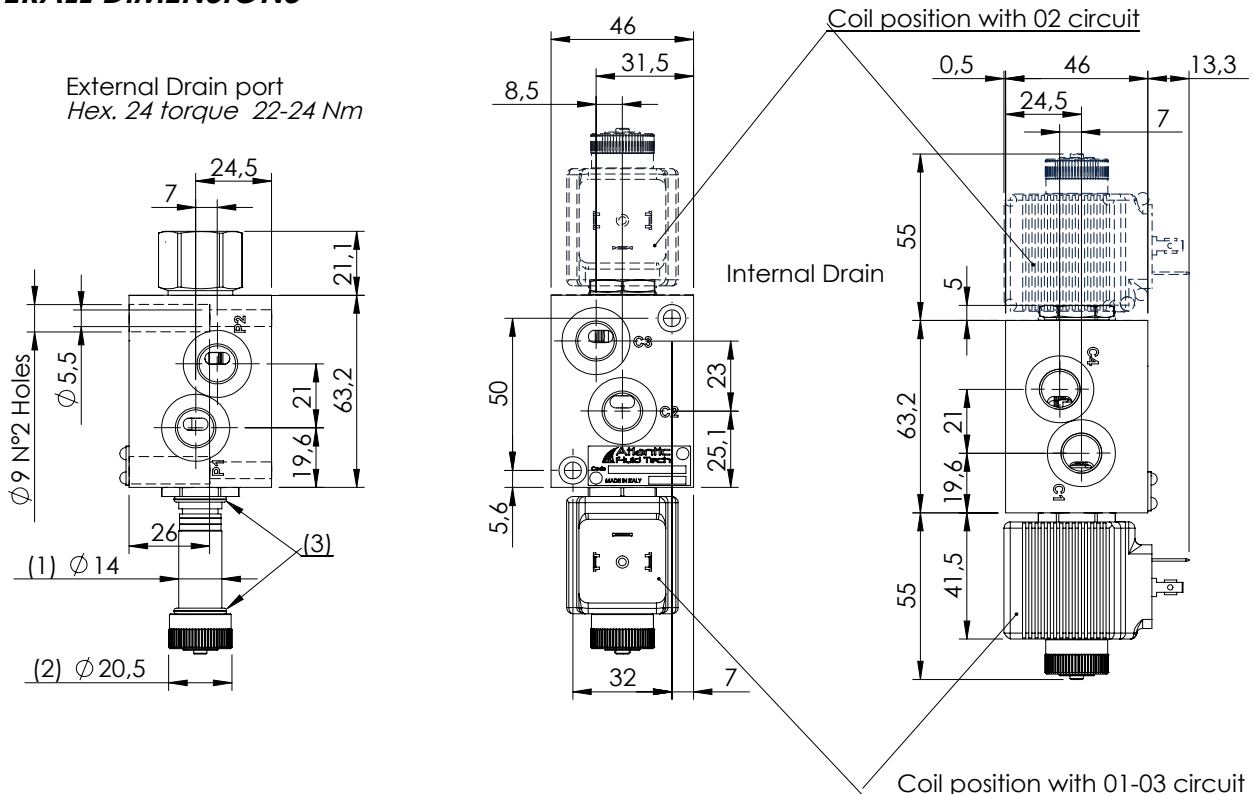

- (1) Solenoid tube hex.17 - Torque 22-24 Nm
- (2) Ring nut for coil locking - Torque 5-6 Nm
- (3) O-Ring Ø 14,00 x 1,78

Characteristic curves

Measured with hydraulic fluid ISO-VG46 at 40° ± 5°C

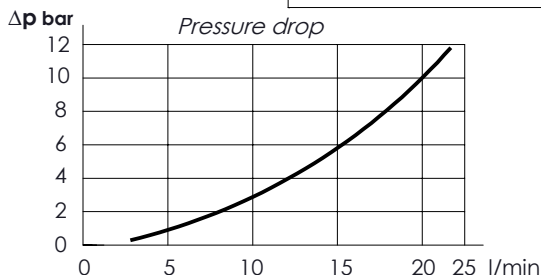
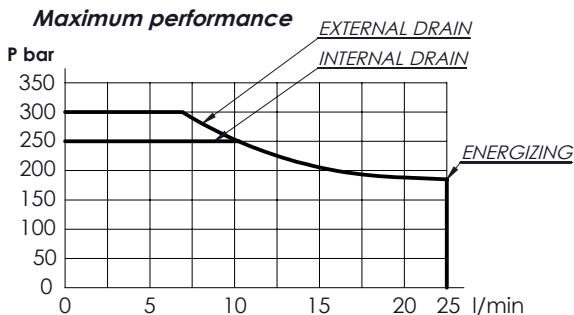

Internal leakage on C ports : MAX 15 cm³/min Mineral oil with 32 cSt viscosity, at 40° C and 100 bar pressure

*	OPERATED	<i>Circuit</i>	*	MANUAL OVERRIDE	*	DRAIN	<i>Circuit</i>															
E	Electric 		S	Standard 	N	Internal 																
N	Hydraulic/pneumatic 		V	Screw 	E	External 																
			N	Without manual override	<table border="1"> <tr> <th colspan="3">PORTS</th> </tr> <tr> <td>***</td> <td>Main (C)</td> <td>Drain (D)</td> </tr> <tr> <td>G14</td> <td>1/4" Gas</td> <td>1/4" Gas</td> </tr> <tr> <td></td> <td></td> <td></td> </tr> <tr> <td colspan="3">Other port sizes available</td> </tr> </table>			PORTS			***	Main (C)	Drain (D)	G14	1/4" Gas	1/4" Gas				Other port sizes available		
PORTS																						
***	Main (C)	Drain (D)																				
G14	1/4" Gas	1/4" Gas																				
Other port sizes available																						

(4) Hydraulic or pneumatic pilot connector: hex 30 mm - Torque 20-22 Nm
With external drain Pilot Pressure Min. 5 bar
With internal drain Pilot Pressure is 1/10 of the working pressure

N - Seals in NBR
V - Seals in VITON

ELFB - 025 - * * A * - ** - * - * ** ***

*	Voltage (V)	Resistance (Ω) ± 7%	Power (W)	Current (A)
-	Without coil			
A	12 DC	5,53	26	2,17
B	24 DC	22,1	26	1,08
Other voltages available on request				

*	COIL	Type	Protection class
-	Without coil		
HR	DIN 43650 - ISO 4400 Class H	M14	IP65
AJ	AMP JUNIOR Class H	M14	IP65
DT	DEUTSCH DT04-2P-L Class H	M14	IP69

FLOW DIVERTERS

ESFB-025

**6 WAYS SINGLE & BANKABLE
FLOW DIVERTERS**



**	Circuit	Transit position
01		
02		
03		

*Only external drain

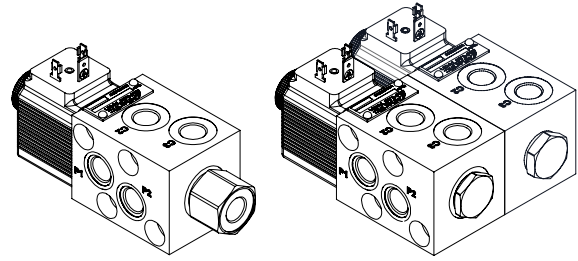

Mounting example

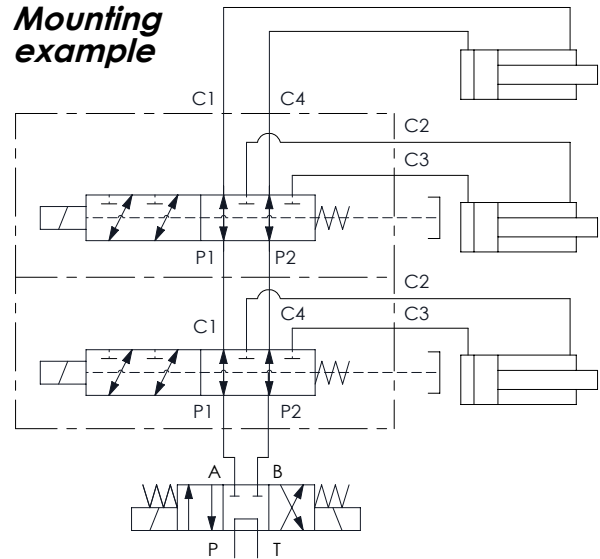

Technical data

Rated flow	l/min	25
Operating pressure	with internal drain "N"	bar 250
	with external drain "E"	bar 310
Valve weight	Kg	1

OVERALL DIMENSIONS

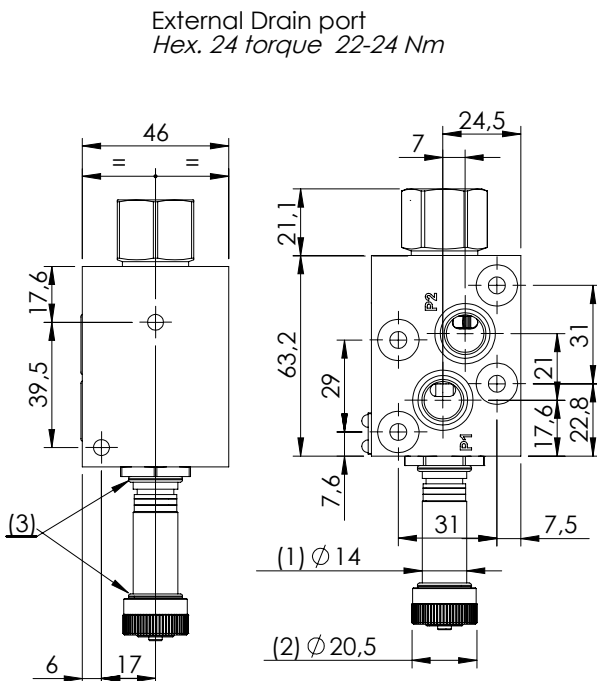

Coil position with 02 circuit

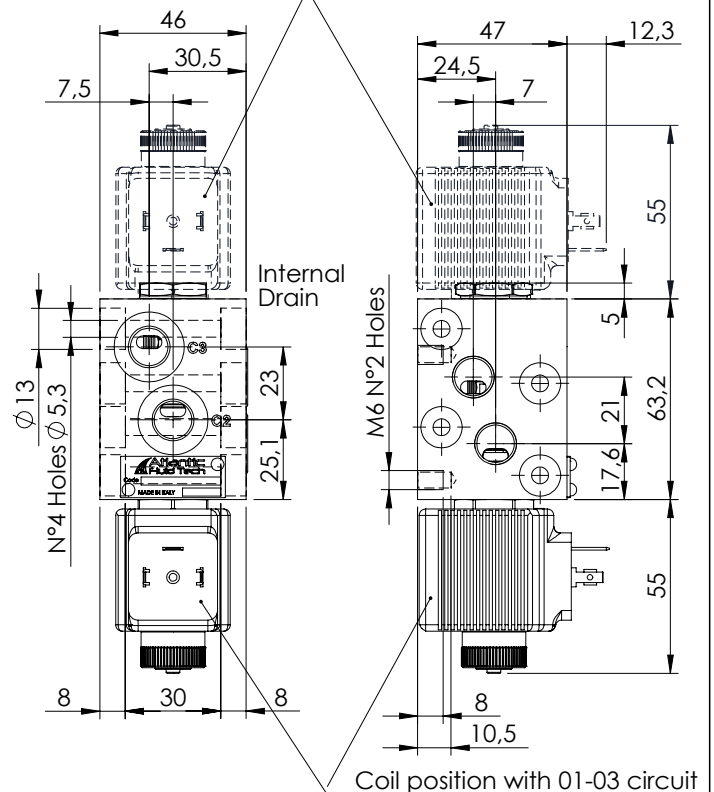

- (1) Solenoid tube hex.17 - Torque 22-24 Nm
- (2) Ring nut for coil locking - Torque 5-6 Nm
- (3) O-Ring Ø 14,00 x 1,78

FLOW DIVERTERS

ESFB-050

**6 WAYS SINGLE & BANKABLE
FLOW DIVERTERS**



**	Circuit	Transit position
01		
02		
03		

*Only external drain

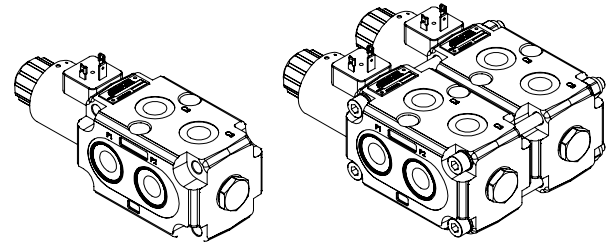

Mounting example

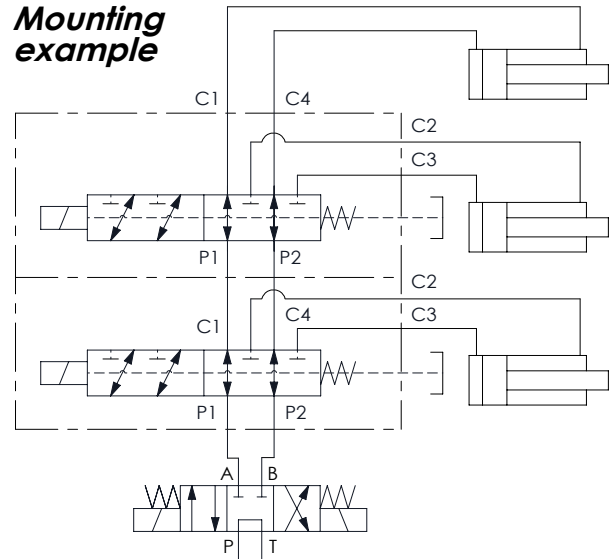

Technical data			
Rated flow	l/min		50
Operating pressure	with internal drain "N"	bar	250
	with external drain "E"	bar	350
	on port D	bar	210
Valve weight	Kg		3,8

OVERALL DIMENSIONS

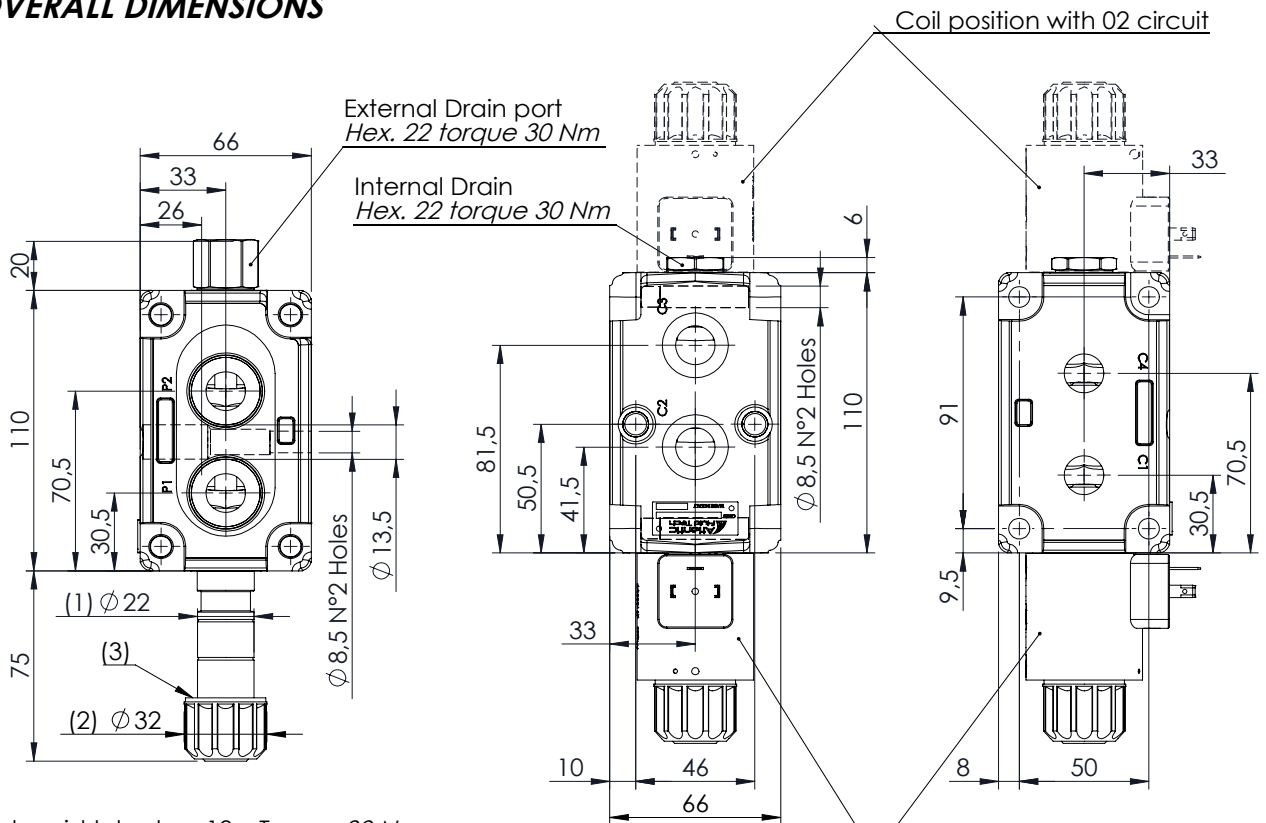

- (1) Solenoid tube hex.19 - Torque 30 Nm
- (2) Ring nut for coil locking - Torque 5-6 Nm
- (3) O-Ring Ø 21,5 x 2

Characteristic curves

Measured with hydraulic fluid ISO-VG46 at 40° ± 5°C

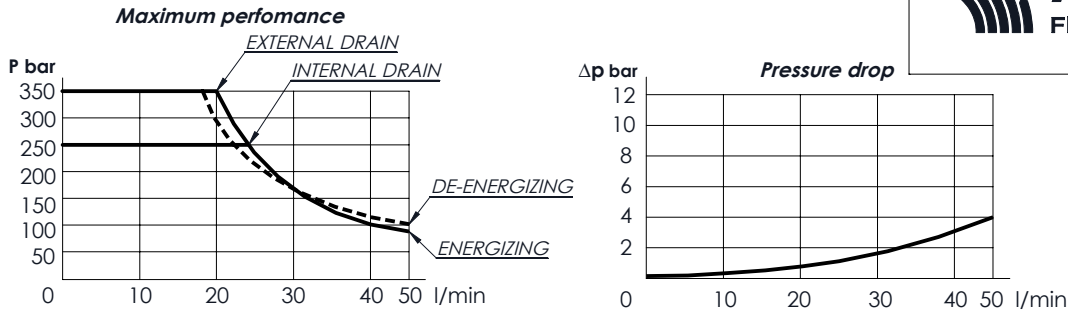

Internal leakage on C ports :
MAX 25 cm³/min
Mineral oil with 32 cSt
viscosity, at 40° C and
100 bar pressure

* OPERATED	Circuit
E Electric 	
N Hydraulic/pneumatic 	

(4) Hydraulic or pneumatic pilot connector:
hex 30 mm - Torque 20-22 Nm
With external drain Pilot Pressure Min. 5 bar
With internal drain Pilot Pressure is 1/10 of the working pressure

* MANUAL OVERRIDE	
S Standard	
V Screw	
N Without manual override	

* DRAIN	Circuit
N Internal	
E External	

***	Main (C)	Drain (D)
PORTS		
G38	3/8" Gas	1/4" Gas
J38	3/8" JIS	1/4" JIS
S08	3/4-16 UNF	7/16-20 UNF

Other port sizes available

CIRCUIT

N - Seals in NBR
V - Seals in VITON

ESFB - 050 - * * D * - ** - * - * ** * ****

* Voltage (V)	Resistance (Ω) ± 7%	Power (W)	Current (A)
-	Without coil		
A 12 DC	4,41	32,7	2,72
B 24 DC	18,6	31	1,29

Other voltages available on request

* COIL	Type	Protection class
-	Without coil	
HR	DIN 43650 - ISO 4400 Class H	M12 IP65
AJ	AMP JUNIOR Class H	M12 IP65
DT	DEUTSCH DT04-2P-L Class H	M12 IP69

TYPE OF MOUNTING

* Port number	Screw Tie rods	Installation torque
-	6	-
08	8 M8x125	15-17 Nm
10	10 M8x190	15-17 Nm
12	12 M8x255	15-17 Nm
14	14 M8x320	15-17 Nm

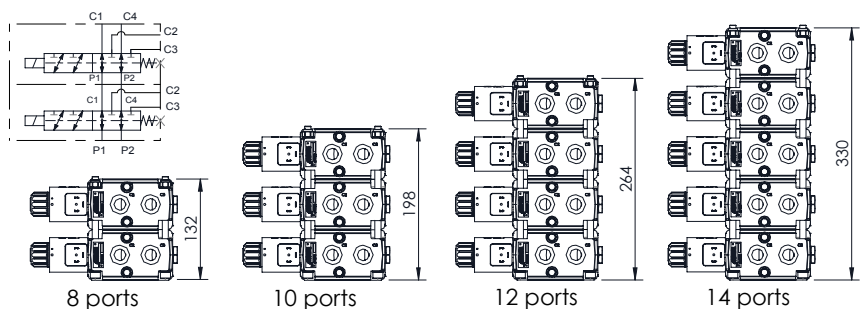

FLOW DIVERTERS

ESFB-100

**6 WAYS SINGLE & BANKABLE
FLOW DIVERTERS**



**	Circuit	Transit position
01		
02		
03		

*Only external drain

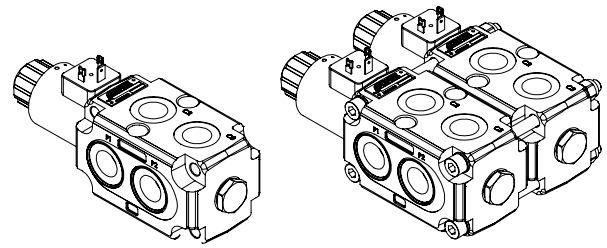

Mounting example

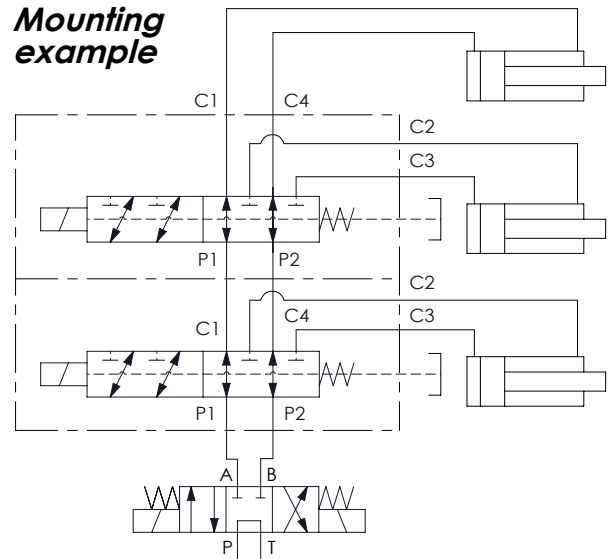

Technical data

Rated flow	l/min	100
Operating pressure	with internal drain "N"	bar 250
	with external drain "E"	bar 350
	on port D	bar 210
Valve weight	Kg	3,8

OVERALL DIMENSIONS

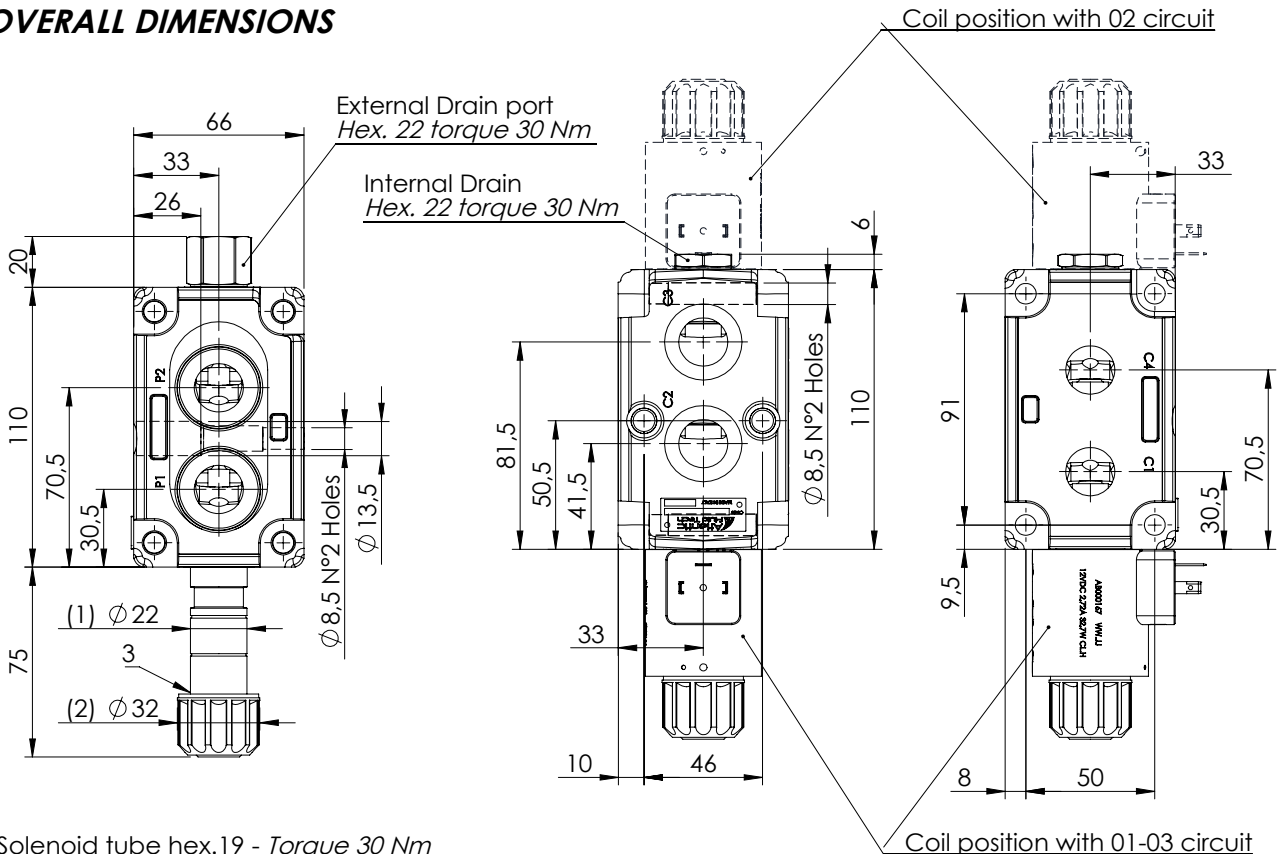

- (1) Solenoid tube hex.19 - Torque 30 Nm
- (2) Ring nut for coil locking - Torque 5-6 Nm
- (3) O-Ring Ø 21,5 x 2

Characteristic curves

Measured with hydraulic fluid ISO-VG46 at 40° ± 5°C

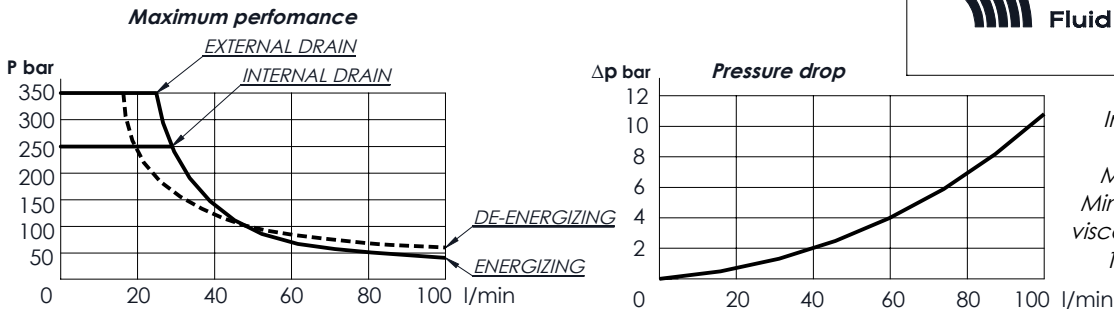

Internal leakage on C ports :
MAX 25 cm³/min
Mineral oil with 32 cSt
viscosity, at 40° C and
100 bar pressure

* OPERATED	Circuit
E Electric	
N Hydraulic/pneumatic	

(4) Hydraulic or pneumatic pilot connector:
hex 30 mm - Torque 20-22 Nm
With external drain Pilot Pressure Min. 5 bar
With internal drain Pilot Pressure is 1/10 of
the working pressure

* MANUAL OVERRIDE	Circuit
S Standard	
V Screw	
N Without manual override	

* DRAIN	Circuit
N Internal	
E External	

PORTS		
***	Main (C)	Drain (D)
G12	1/2" Gas	1/4" Gas
J12	1/2" JIS	1/4" JIS
S10	7/8-14 UNF	7/16-20 UNF
Other port sizes available		

N - Seals in NBR
V - Seals in VITON

CIRCUIT

ESFB - 100 - * * D * - ** - * - * ** * ****

* Voltage (V)	Resistance (Ω) ± 7%	Power (W)	Current (A)
-	Without coil		
A 12 DC	4,41	32,7	2,72
B 24 DC	18,6	31	1,29
Other voltages available on request			

* COIL	Type	Protection class
-	Without coil	
HR	DIN 43650 - ISO 4400 Class H	M12 IP65
AJ	AMP JUNIOR Class H	M12 IP65
DT	DEUTSCH DT04-2P-L Class H	M12 IP69

TYPE OF MOUNTING

* Port number	Screw Tie rods	Installation torque
-	-	-
08	M8x125	15-17 Nm
10	M8x190	15-17 Nm
12	M8x255	15-17 Nm
14	M8x320	15-17 Nm

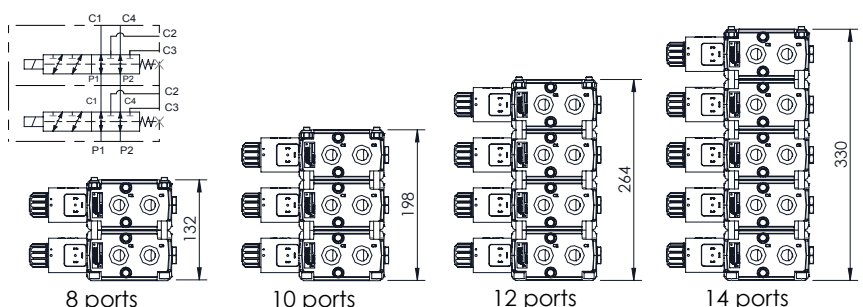

FLOW DIVERTERS

ELFB-400

**6 WAYS SINGLE IN LINE
FLOW DIVERTERS**

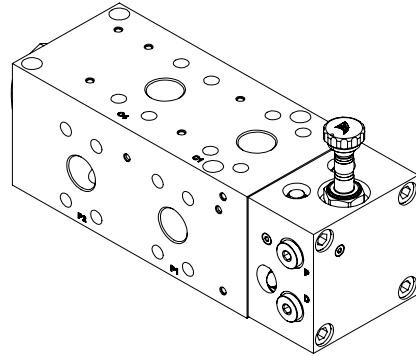
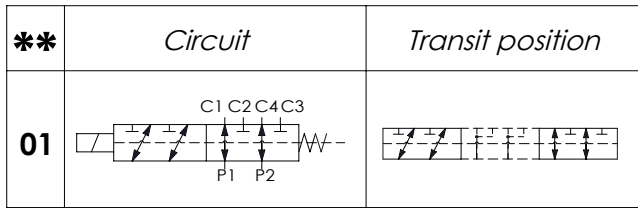

Technical data			
Rated flow		l/min	400
Operating pressure	with internal drain "N"	bar	210
	with external drain "E"	bar	420
Minimum pilot pressure		bar	20
Valve weight		Kg	17,2
Standard Ports		1" SAE 6000	

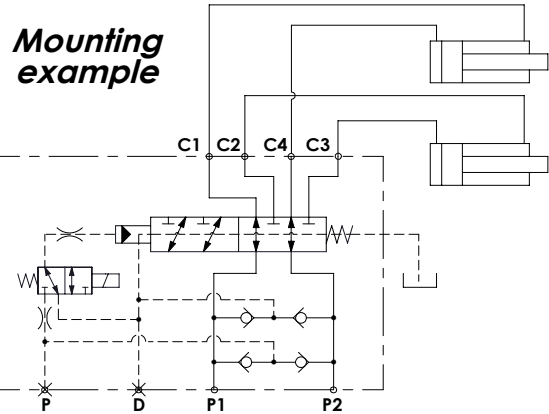

OVERALL DIMENSIONS

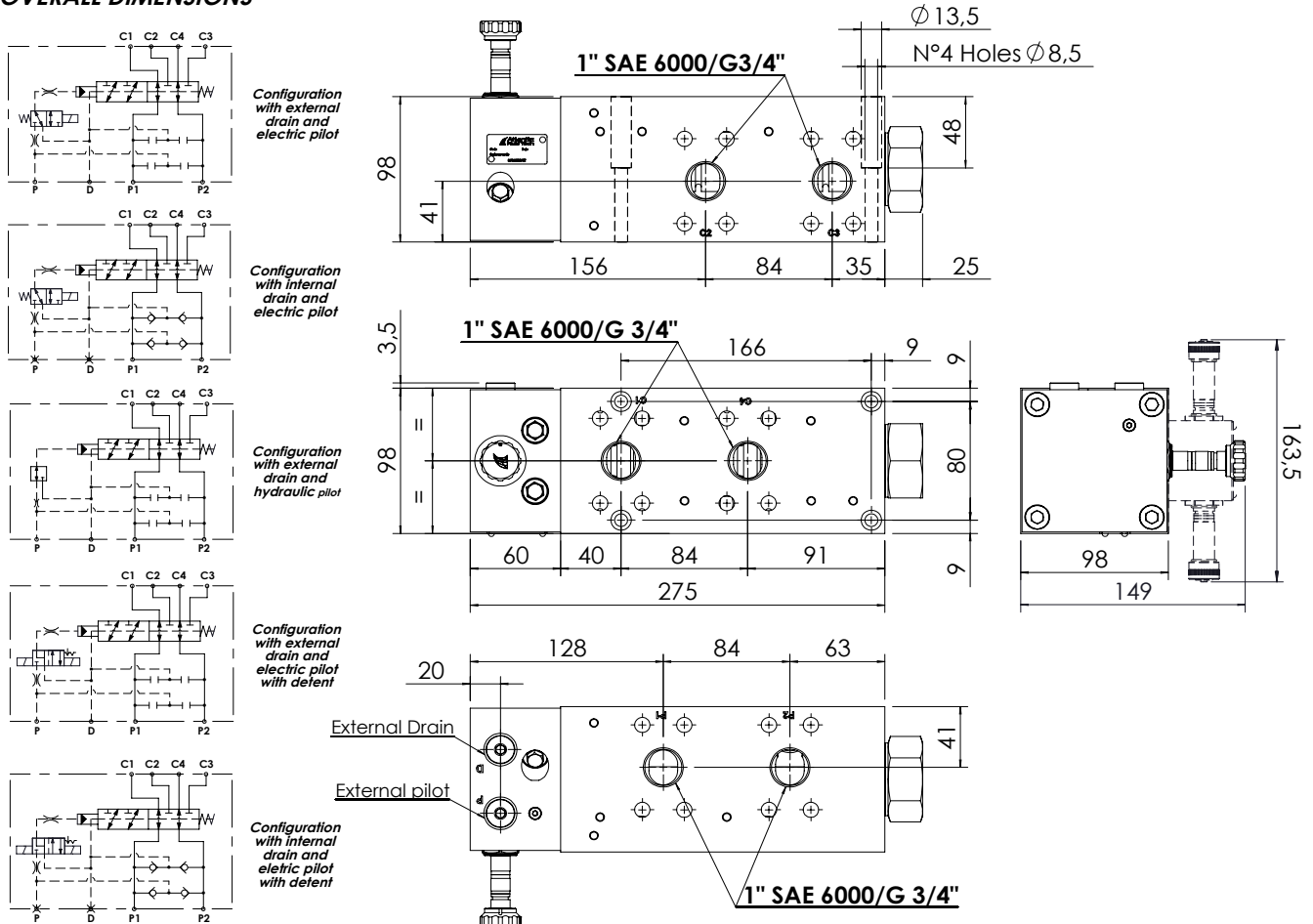

Characteristic curves

With pressure and flow in P1 or P2 and C4 and C1 without pressure



Maximum performance

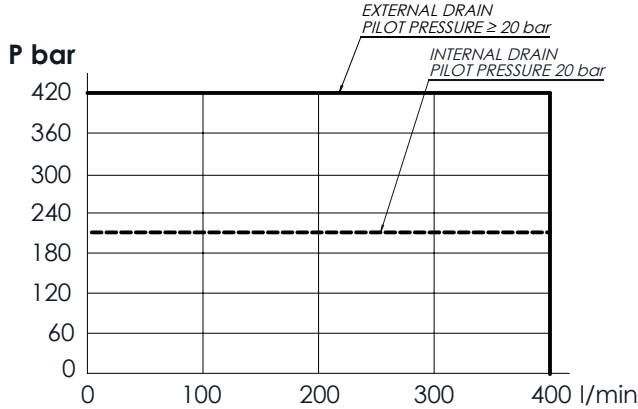

Δp bar

Pressure drop

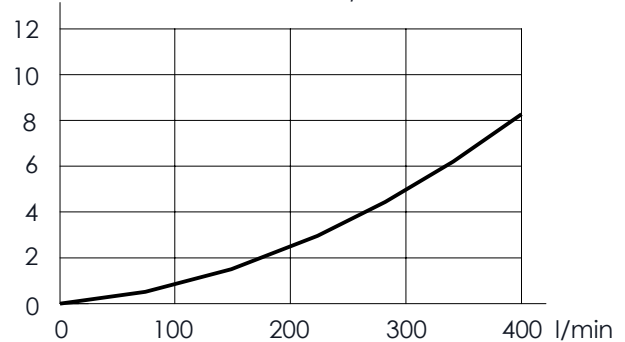

* OPERATED	Circuit
H Hydraulic 	
E Electric 	
D Electric with detent 	

Max. pilot pressure with external drain: 250 bar

* DRAIN	Circuit
N Internal	
E External	

* COIL	Type	Protection class
-	Without coil	
HR	DIN 43650 - ISO 4400 Class H	M7 IP65
AJ	AMP JUNIOR Class H	M7 IP65
DT	DEUTSCH DT04-2P-L Class H	M7 IP69

PORTS		
***	Main (C)	Drain (D) Pilot (P)
S10 G34	1" SAE 6000 G3/4"	1/4" Gas

Special port sizes available

CIRCUIT

V - Seals in VITON

ELFB - 400 - * S F * - 01 - * - * ** ***

* Voltage (V)	Resistance (Ω) $\pm 7\%$	Power (W)	Current (A)
-	Without coil		
A 12 DC	7,2	20	1,67
B 24 DC	28,7	20	0,84

Special voltages available on request

KIT	Type	Ordering code
HP	Hydraulic pilot	RG100032
EP	Electrical pilot	CE000824
ID	Internal drain	RG100033
ED	External drain	RG100034

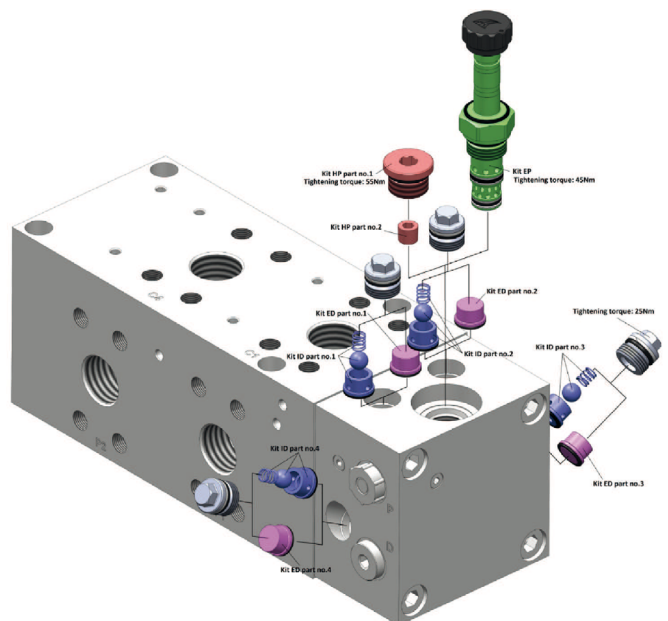

EXCAVATORS VALVE

ELHB-010-DSGN

8 WAYS WITH DETENT

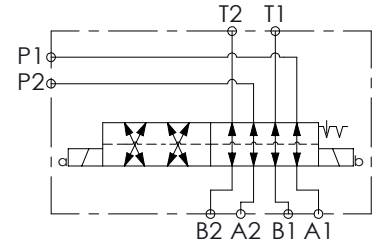
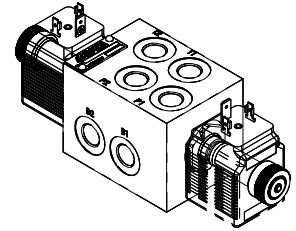
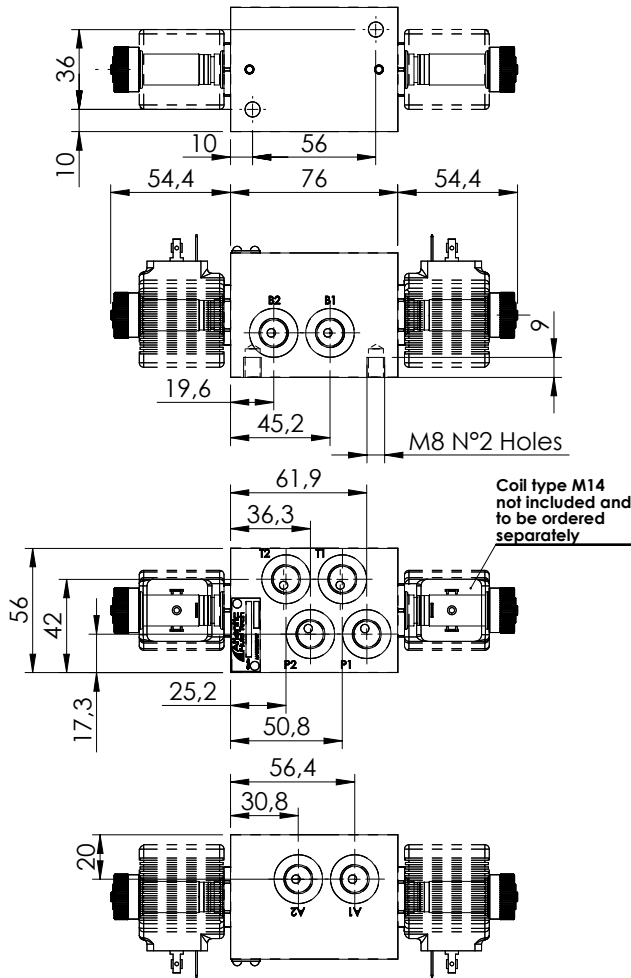

SPECIFICATIONS

Max. operating pressure:	210 bar
Rated flow:	10 l/min
Body:	Cast Iron
Weight:	1,82 kg
Coil type:	M14 type

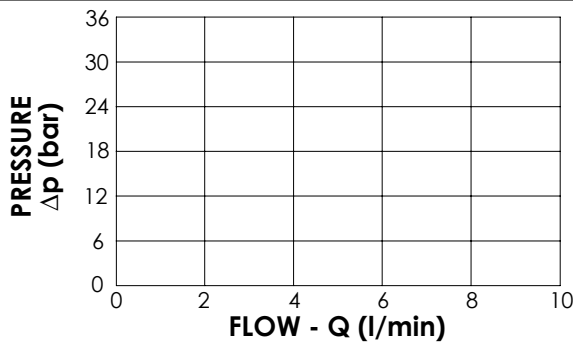

NOTES

See the chapter 18.00.000 for coil.

ORDERING CODES

Quick code	Description	Ports size	
ES000390	ELHB-010-DSGN-39-G14-N	G 1/4"	



ATLANTIC
Fluid Tech

SECTION 18

Modular
Valves for
Cetop



1800-OILSOL
1800-645765

<https://oilsolutions.com.au/>

sales@oilsolutions.com.au

SECTION 18

MODULAR VALVES FOR CETOP



Hydraulic scheme	Valve description	Valve type	Rated flow (l/min)	Max. pressure (bar)	Installation	Main port size or cavity type	Page
	BNND-040-LE	Left version	40	210	Flanged	Cetop 3	18.01.010
	BNND-040-LE	Right version	40	210	Flanged	Cetop 3	18.01.010
	BNFN-040-NT	Pilot operated, cetop 3	40	210	Flanged	Cetop 3	18.02.020
	KPLN-030-DPNA	Direct acting, cetop 3	30	210	Flanged	Cetop 3	18.03.030
	KPLN-030-DPNA	Direct acting, poppet type, subplate cetop 3	30	350	Flanged	Cetop 3	18.04.040
	KPLN-080-DPNA	Direct acting, poppet type, subplate cetop 5	80	350	Flanged	Cetop 5	18.04.050
	KPLT-030-DPNA	Direct acting, compensated	30	210	Flanged	Cetop 3	18.05.060
	MBSN-060-ZTNR	Single acting, cetop 3	60	250	Flanged	Cetop 3	18.06.070
	MBSN-060-ATNR	Single acting, cetop 3	60	350	Flanged	Cetop 3	18.06.080
	MBST-100-ZTNP	Single acting, cetop 5	100	250	Flanged	Cetop 5	18.07.090
	MBDN-030-LTNR	Double acting, cetop 3	30	210	Flanged	Cetop 3	18.08.100
	MBDN-060-ZTNR	Double acting, cetop 3	60	210	Flanged	Cetop 3	18.08.110
	MBDN-060-ATNR	Double acting, cetop 3	60	350	Flanged	Cetop 3	18.08.120
	MBDN-100-ZTNR	Double acting, cetop 5	100	350	Flanged	Cetop 5	18.08.130
	MBDP-060-ZTNR	Double acting, cetop 3	60	210	Flanged	Cetop 3	18.10.140
	MBDT-100-ATNR	Double acting, cetop 5	100	350	Flanged	Cetop 5	18.09.150

MODULAR VALVE FOR CETOP

BNND-040-LE

CETOP 3

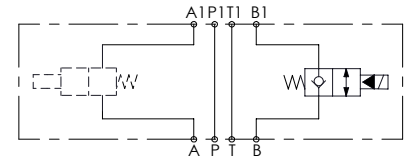
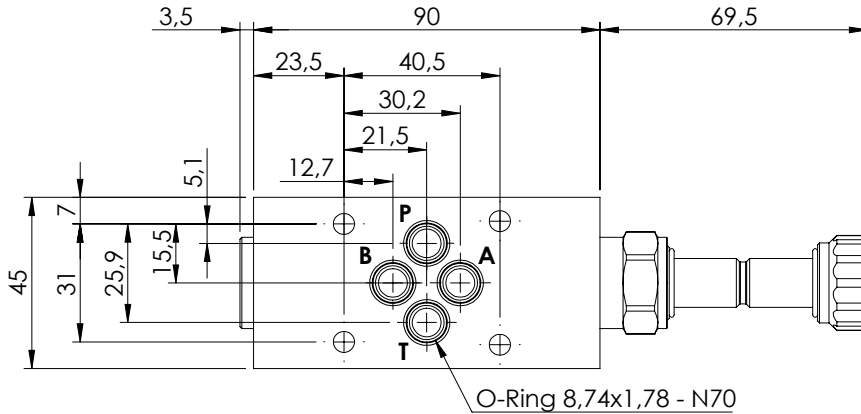
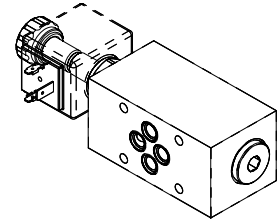

Coil type M7 not included and to be ordered separately

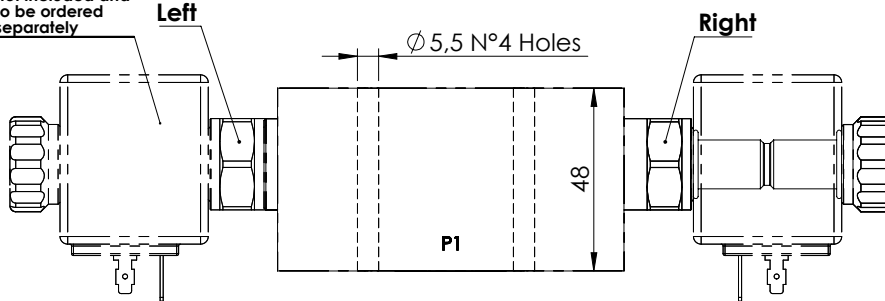

SPECIFICATIONS

Max. operating pressure:	210 bar
Rated flow:	40 l/min
Cavity:	Aluminium
Weight:	0,61 kg
Coil type:	M7

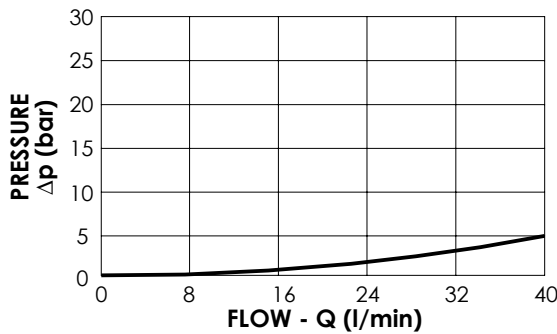

NOTES

ORDERING CODES

Quick code	Description	Main ports size	Version
BD000034	BNND-040-LE-N06-N210-R	A,B,P,T: CETOP 3	Right
BD000119	BNND-040-LE-N06-N210-L	A,B,P,T: CETOP 3	Left

MODULAR VALVE FOR CETOP

BNFN-040-NT

CETOP 3

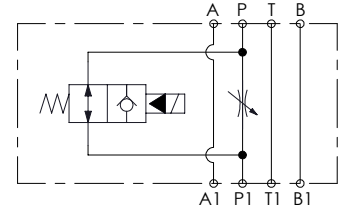
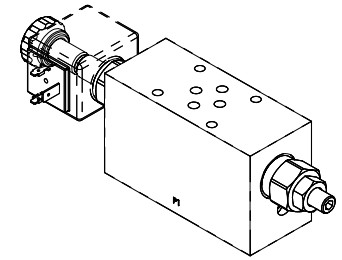
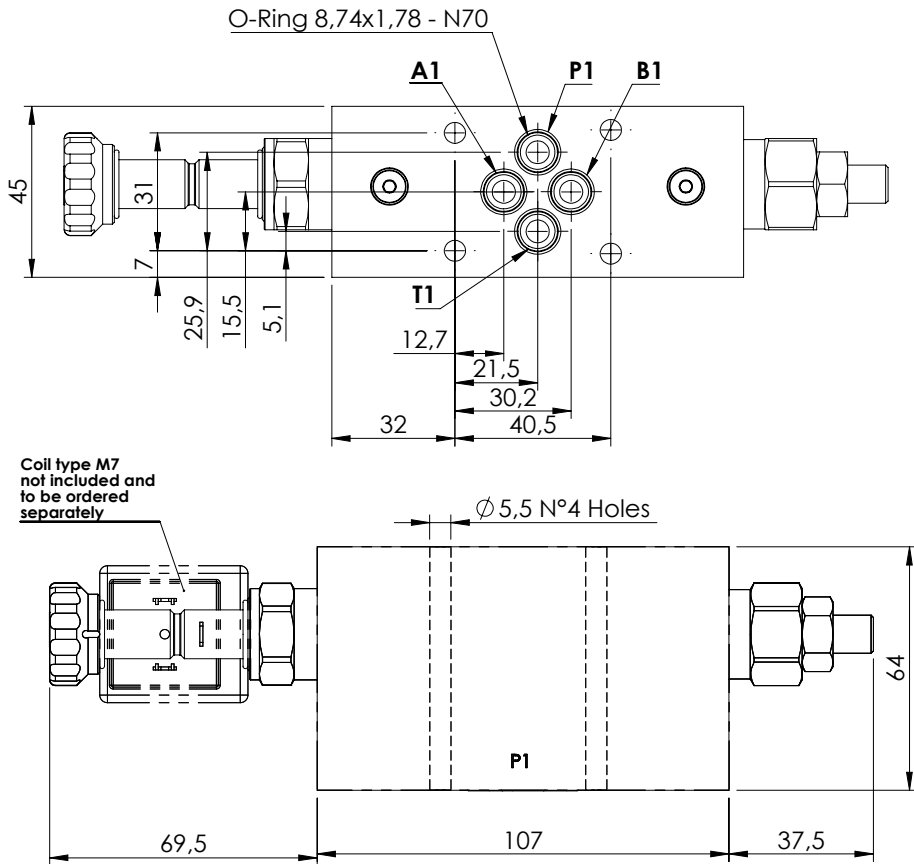

SPECIFICATIONS

Max. operating pressure:	210 bar
Rated flow:	40 l/min
Manifold:	Aluminium
Weight:	1 kg
Coil type:	M7

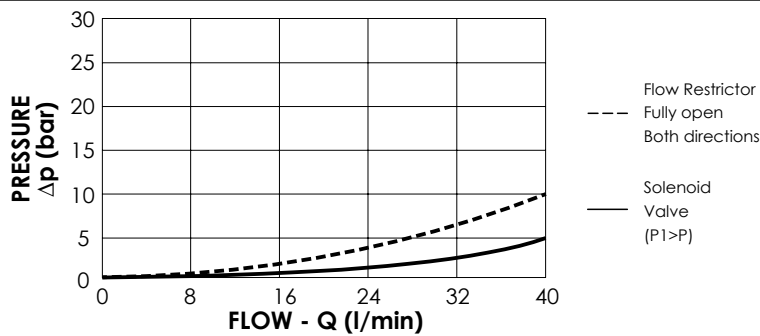

NOTES

ORDERING CODES

Quick code	Description	Main ports size
BF000004	BNFN-040-NT-N06-N210	A,B,P,T: CETOP 3

MODULAR VALVE FOR CETOP

KPLN-030-DPNA

CETOP 3

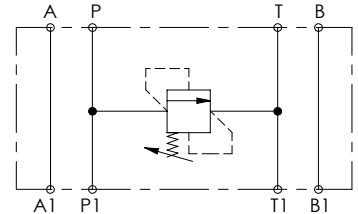
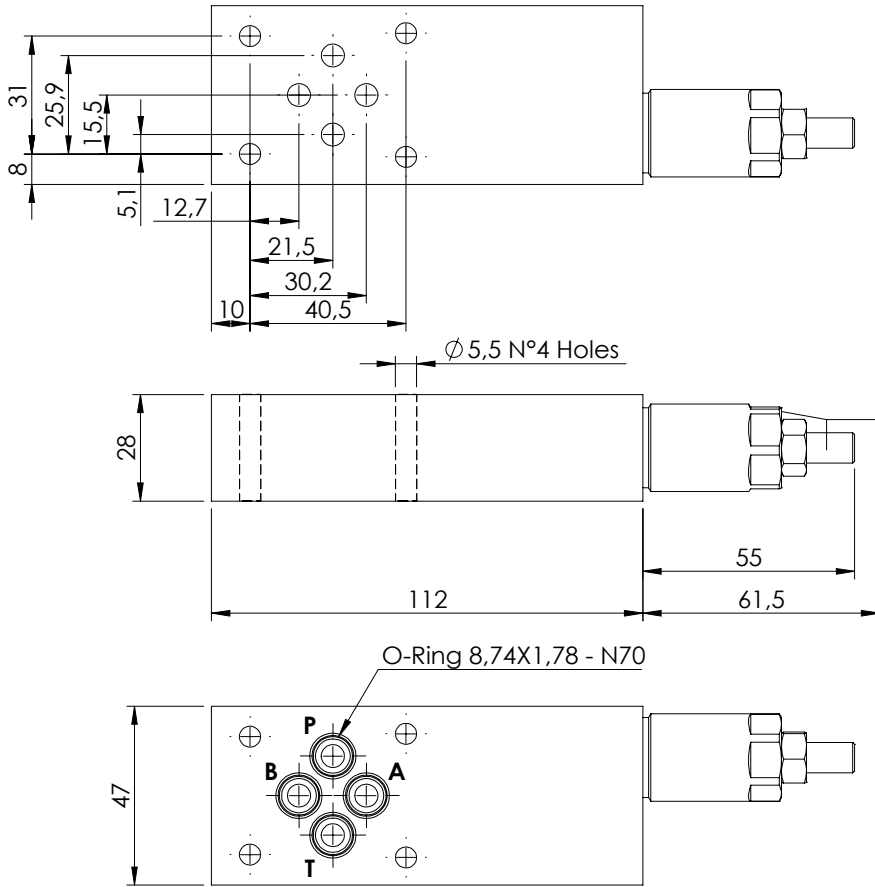
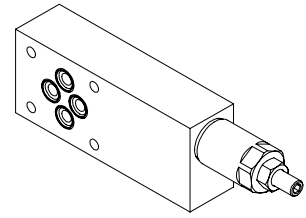

SPECIFICATIONS

Max. operating pressure:	210 bar
Rated flow:	30 l/min
Manifold:	Aluminium
Weight:	0,52 kg

SEALING CAP

Ordering code:
AT000020

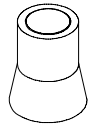

NOTES

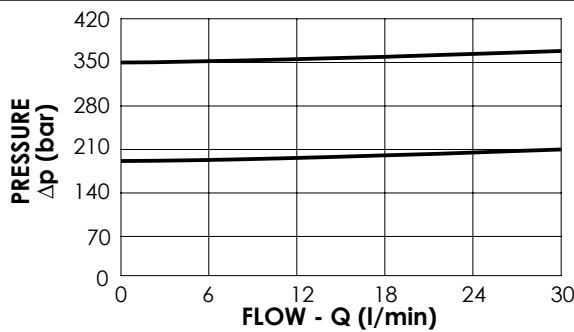

ORDERING CODES

Quick code	Description	Main ports size	Standard setting (bar, Q=5 l/min)	Adjustm. range (bar)	Pressure increase (bar/turn)
KP000170	KPLN-030-DPNA-HN-N06-N350	A,B,P,T: CETOP 3	350	100-350	91
KP000112	KPLN-030-DPNA-HN-N06-N200	A,B,P,T: CETOP 3	200	50-210	42

MODULAR VALVE FOR CETOP

KPLN-030-DPNA

**CETOP 3
SUBPLATE**

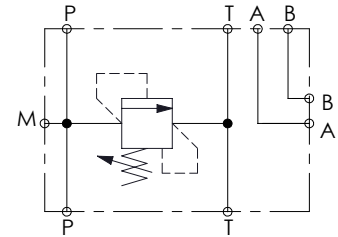
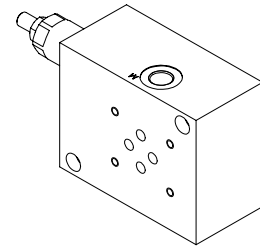
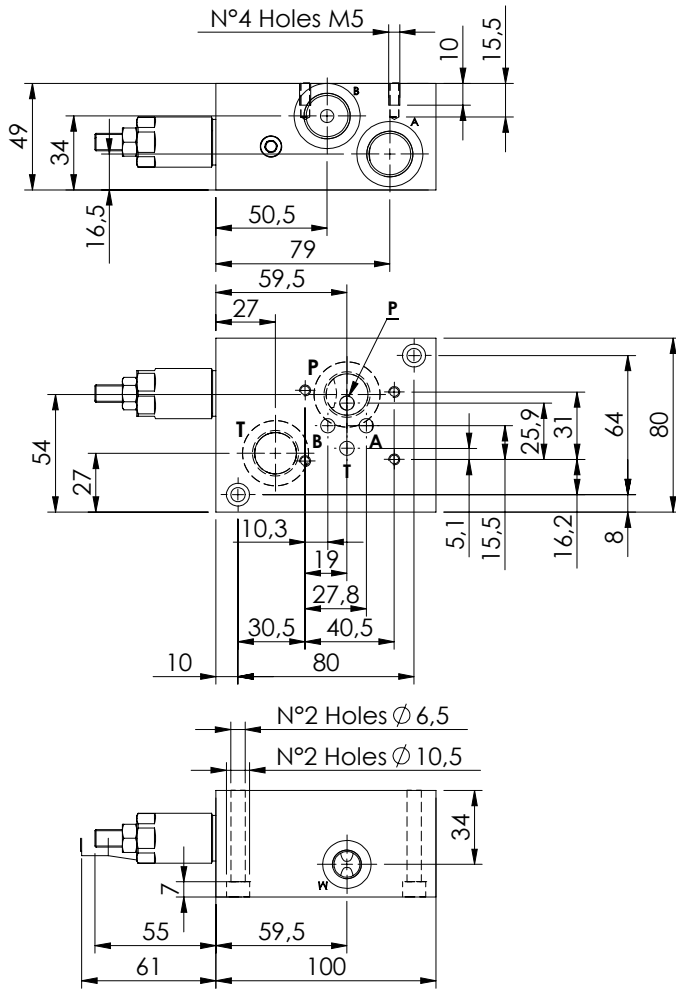

SPECIFICATIONS

Max. operating pressure:	350 bar
Rated flow:	30 l/min
Manifold:	Aluminium
Weight:	1,04 kg

SEALING CAP

Ordering code:
AT000020

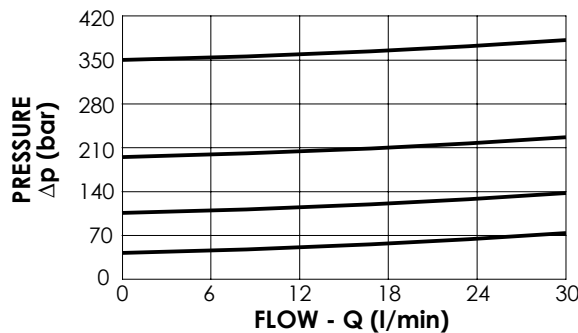
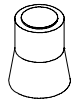

NOTES

ORDERING CODES

Quick code	Description	Main ports size	Standard setting (bar, Q=5 l/min)	Adjustm. range (bar)	Pressure increase (bar/turn)
KP000071	KPLN-030-DPNA-HN-N06-N350	A,B,P,T : CETOP 3 A,B,P,T : G 1/2" ; M: G1/4"	350	100-350	91
KP000072	KPLN-030-DPNA-HN-N06-N200	A,B,P,T : CETOP 3 A,B,P,T : G 1/2" ; M: G1/4"	200	50-210	42
KP000073	KPLN-030-DPNA-HN-N06-N100	A,B,P,T : CETOP 3 A,B,P,T : G 1/2" ; M: G1/4"	100	30-100	20
KP000074	KPLN-030-DPNA-HN-N06-N050	A,B,P,T : CETOP 3 A,B,P,T : G 1/2" ; M: G1/4"	50	5-50	10

MODULAR VALVE FOR CETOP

KPLN-080-DPNA

**CETOP 5
SUBPLATE**

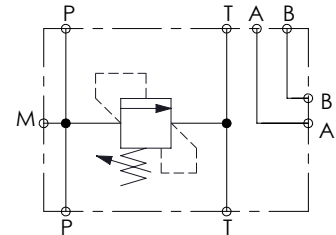
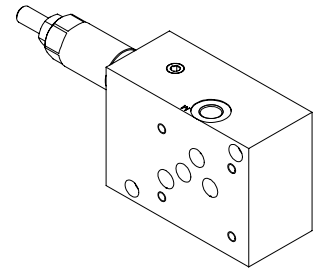
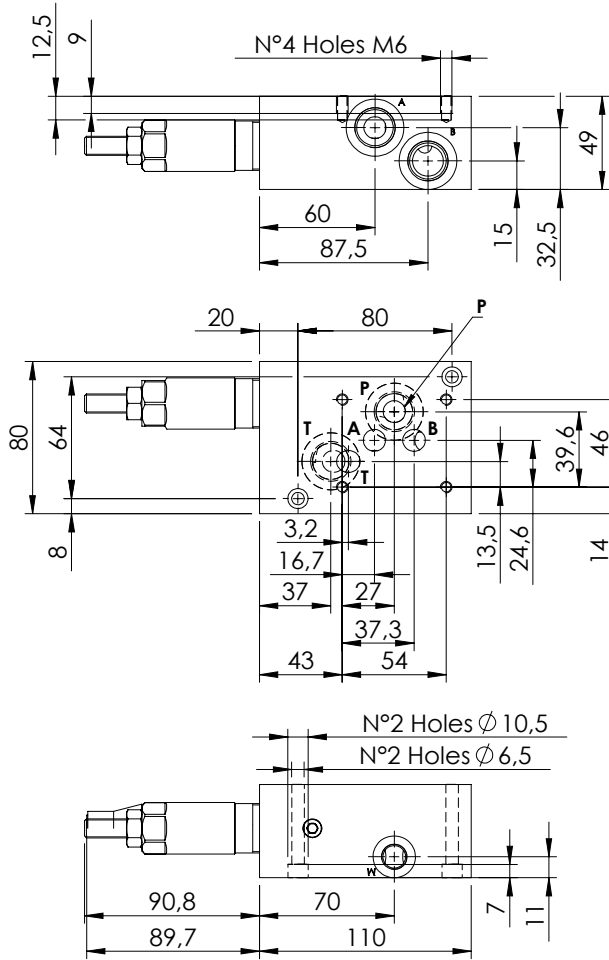

SPECIFICATIONS

Max. operating pressure:	350 bar
Rated flow:	80 l/min
Manifold:	Aluminium
Weight:	1,26 kg

SEALING CAP

Ordering code:
AT000021

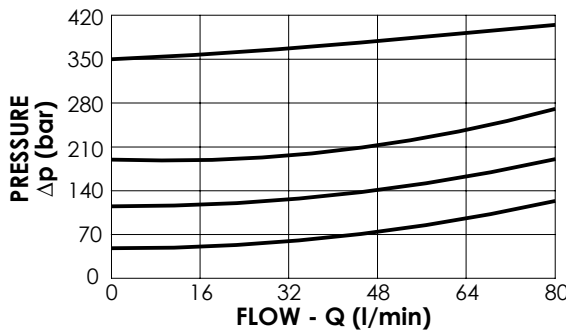
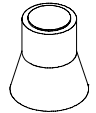

NOTES

ORDERING CODES

Quick code	Description	Main ports size	Standard setting (bar, Q=5 l/min)	Adjustm. range (bar)	Pressure increase (bar/turn)
KP000075	KPLN-080-DPNA-HN-N10-N350	A,B,P,T: CETOP 5 A,B,P,T: G 1/2" ;M: G1/4"	350	100-350	42
KP000076	KPLN-080-DPNA-HN-N10-N200	A,B,P,T: CETOP 5 A,B,P,T: G 1/2" ;M: G1/4"	200	60-210	24
KP000077	KPLN-080-DPNA-HN-N10-N100	A,B,P,T: CETOP 5 A,B,P,T: G 1/2" ;M: G1/4"	100	25-100	13
KP000102	KPLN-080-DPNA-HN-N10-N050	A,B,P,T: CETOP 5 A,B,P,T: G 1/2" ;M: G1/4"	50	5-50	9

MODULAR VALVE FOR CETOP

KPLT-030-DPNA

CETOP 3

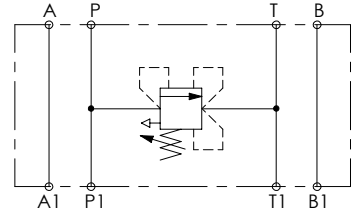
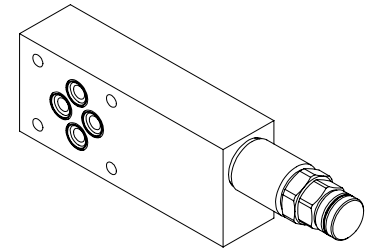
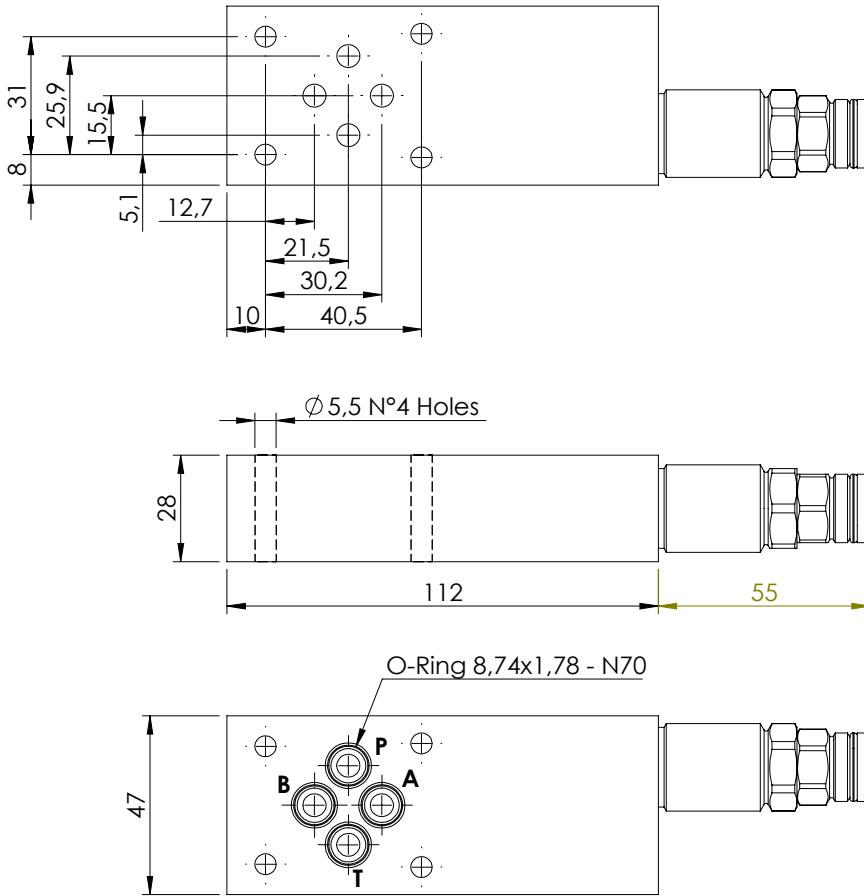

SPECIFICATIONS

Max. operating pressure:	210 bar
Rated flow:	30 l/min
Manifold:	Aluminium
Weight:	0,54 kg

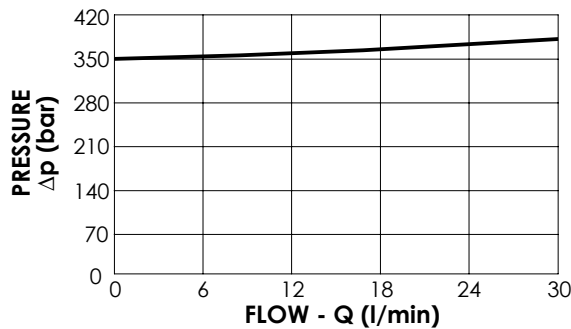

NOTES

ORDERING CODES

Quick code	Description	Main ports size	Standard setting (bar, Q=5 l/min)	Adjustm. range (bar)	Pressure increase (bar/turn)
KP000171	KPLT-030-DPNA-HN-N06-N350	A,B,P,T: CETOP 3	350	100-350	91

MODULAR VALVE FOR CETOP

MBSN-060-ZTNP

**SINGLE ACTING
CETOP 3**



O-Ring 8,74x1,78 - N90

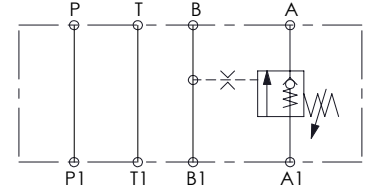
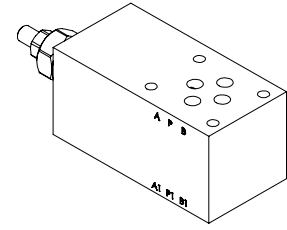
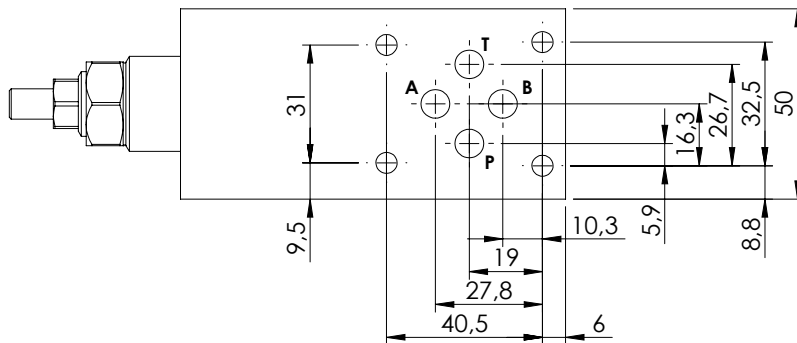
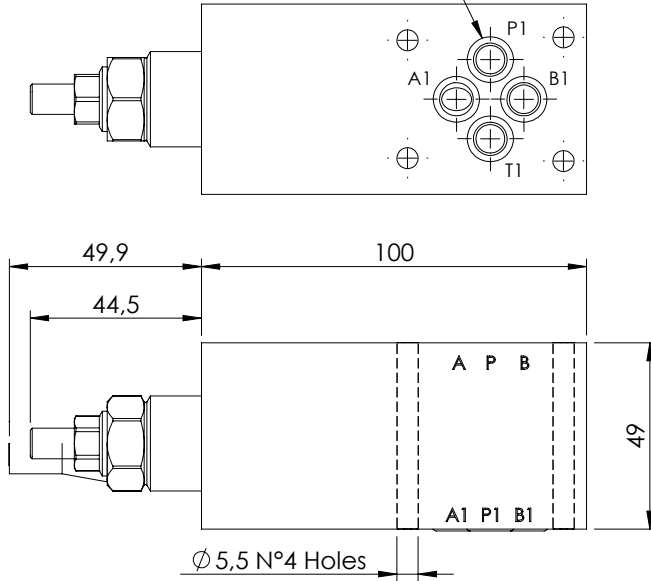

SPECIFICATIONS

Max. operating pressure:	250 bar
Rated flow:	60 l/min
Manifold:	Aluminium
Weight:	724,9 g

SEALING CAP

Ordering code:
AT000020

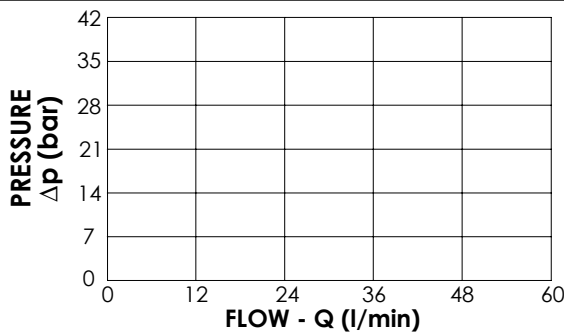
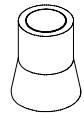

NOTES

Setting: at least 1.3 times the load induced pressure

ORDERING CODES

Quick code	Description	Pilot ratio	Main ports size	Standard setting (bar, Q=5 l/min)	Adjust. range (bar)	Pressure increase (bar/turn)
MB000923	MBSN-060-ZTNP-01-N06-N250	1:0	A,B,P,T: CETOP 3	25	3-30	5

CETOP AND MODULAR VALVE

MBSN-060-ARNR

**SINGLE ACTING
CETOP 3**

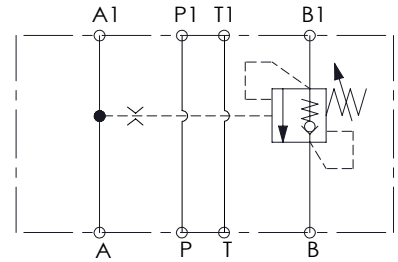
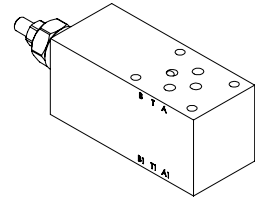
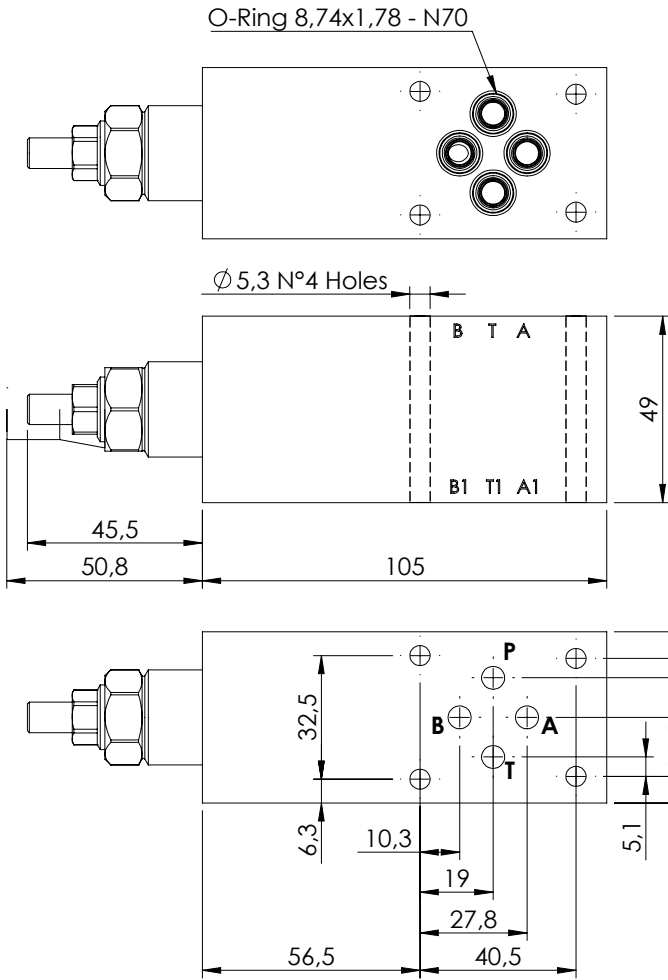

SPECIFICATIONS

Max. operating pressure:	350 bar
Rated flow:	60 l/min
Manifold:	Steel
Weight:	1,78 kg

SEALING CAP

Ordering code:
AT000020

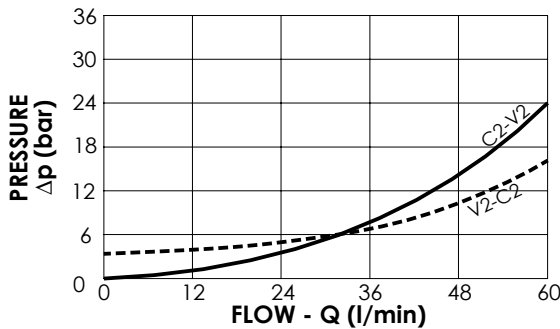
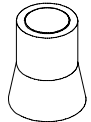

NOTES

Setting: at least 1.3 times the load induced pressure

ORDERING CODES

Quick code	Description	Pilot ratio	Main ports size	Standard setting (bar, Q=5 l/min)	Adjust. range (bar)	Pressure increase (bar/turn)
MB000886	MBSN-060-ATNR-04-N06-N350	4,2:1	A,B,P,T: CETOP 3	350	100-350	139

MODULAR VALVE FOR CETOP

MBST-100-ZTNP

**SINGLE ACTING
CETOP 5**



O-Ring 12,42x1,78 - N70

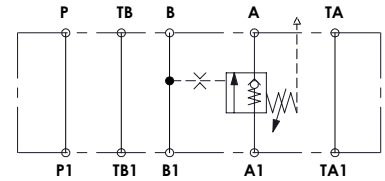
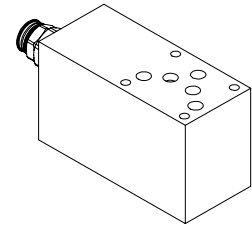
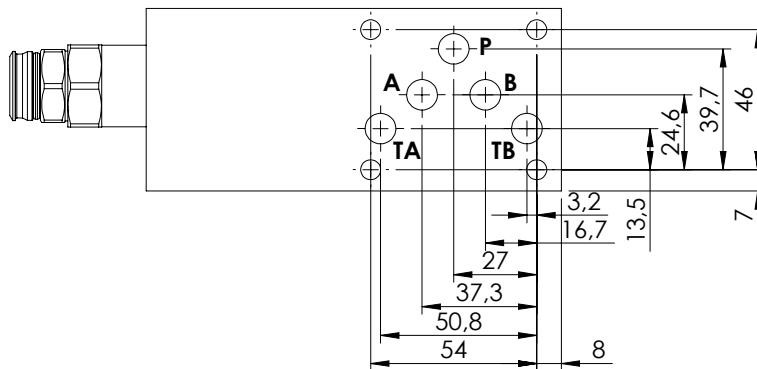
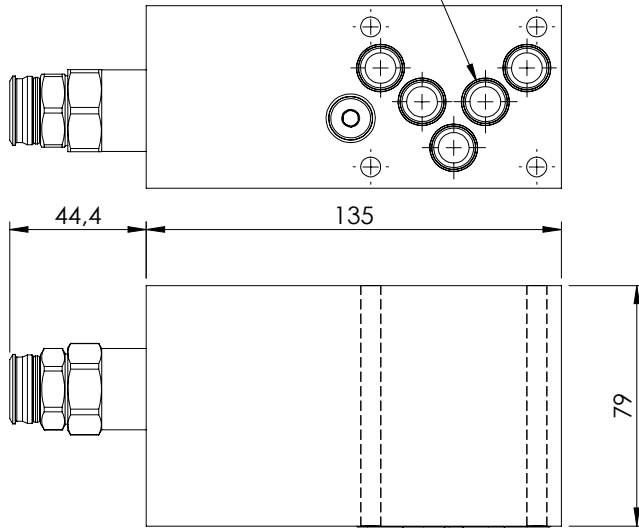

SPECIFICATIONS

Max. operating pressure:	250 bar
Rated flow:	100 l/min
Manifold:	Aluminium
Weight:	1734,8 g

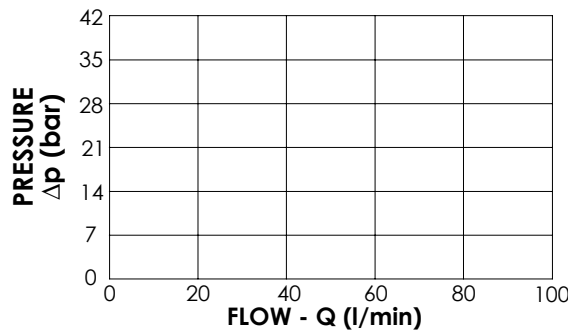

NOTES

Setting: at least 1.3 times the load induced pressure

ORDERING CODES

Quick code	Description	Pilot ratio	Main ports size	Standard setting (bar, Q=5 l/min)	Adjust. range (bar)	Pressure increase (bar/turn)
MB000924	MBST-100-ZTNP-01-T10-N250	1:0	A,B,P,T: CETOP 5	10	3-25	8

MODULAR VALVE FOR CETOP

MBDN-030-LTNR

**DOUBLE ACTING
CETOP 3**

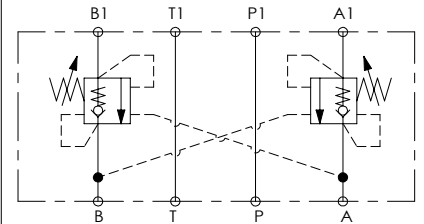
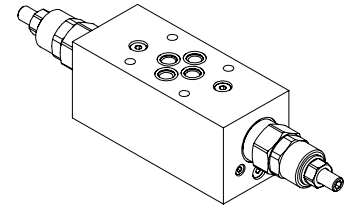
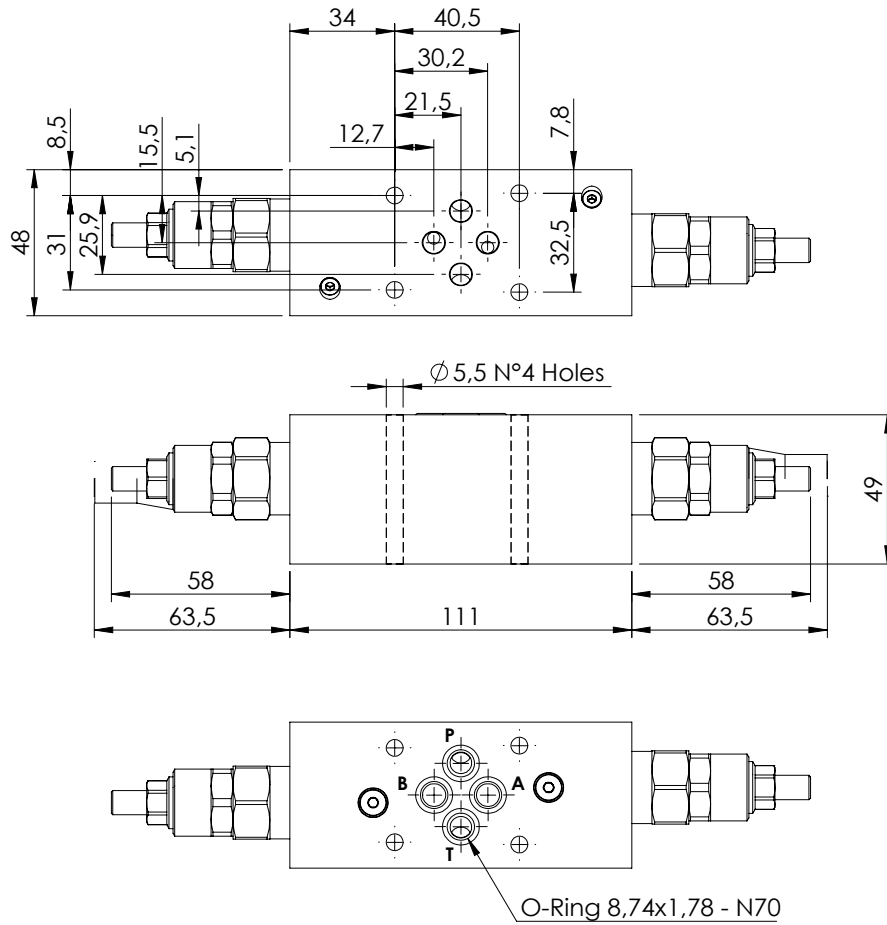

SPECIFICATIONS

Max. operating pressure:	210 bar
Rated flow:	30 l/min
Manifold:	Aluminium
Weight:	1 kg

SEALING CAP

Ordering code:
AT000020

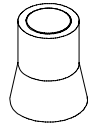

NOTES

Setting: at least 1.3 times the load induced pressure

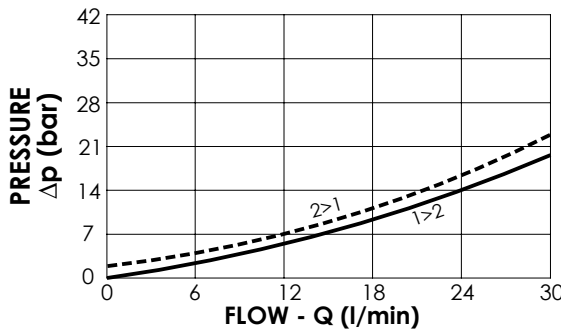

ORDERING CODES

Quick code	Description	Pilot ratio	Main ports size	Standard setting (bar, Q=5 l/min)	Adjust. range (bar)	Pressure increase (bar/turn)
MB000917	MBDN-030-LTNR-04-N06-N210	4:1	A,B,P,T: CETOP 3	200	70-210	93,5

MODULAR VALVE FOR CETOP

MBDN-060-ZTNR

DOUBLE ACTING
CETOP 3

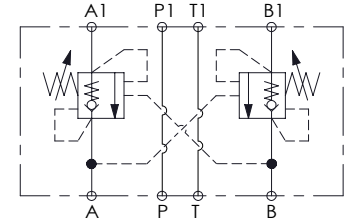
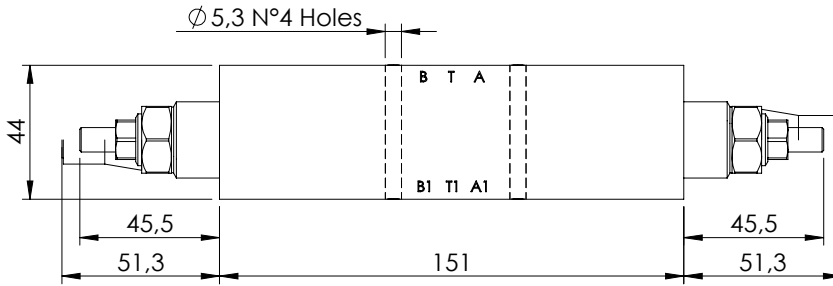
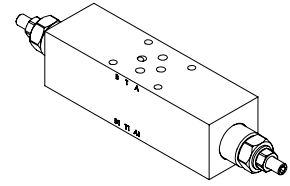
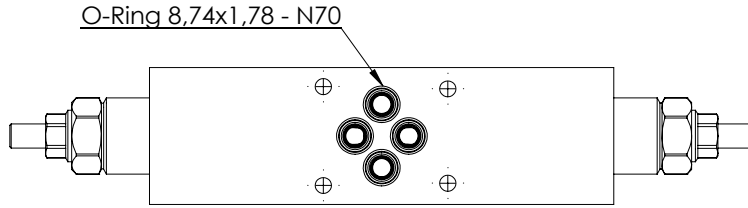

SPECIFICATIONS

Max. operating pressure:	350 bar
Rated flow:	60 l/min
Manifold:	Aluminium
Weight:	1,03 kg

SEALING CAP

Ordering code:
AT000020

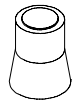

NOTES

Setting: at least 1.3 times the load induced pressure

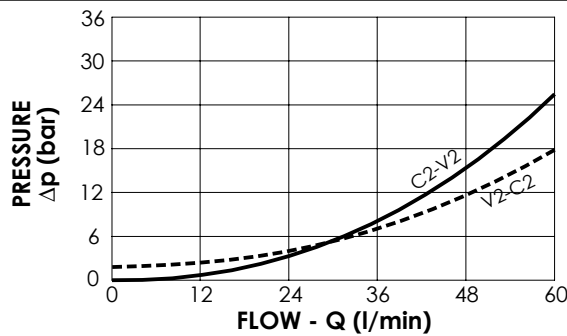
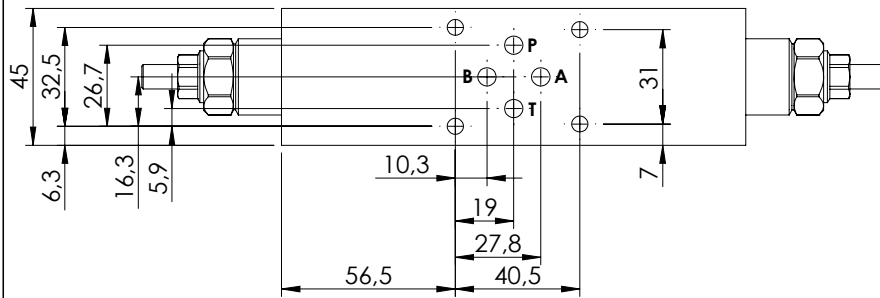

ORDERING CODES

Quick code	Description	Pilot ratio	Main ports size	Standard setting (bar, Q=5 l/min)	Adjust. range (bar)	Pressure increase (bar/turn)
MB000517	MBDN-060-ZTNR-04-N06-N350	4,2:1	A,B,P,T: CETOP 3	350	100-350	138
MB000546	MBDN-060-ZTNR-04-N06-N200	4,2:1	A,B,P,T: CETOP 3	200	60-210	62

MODULAR VALVE FOR CETOP

MBDN-060-ATNR

**DOUBLE ACTING
CETOP 3**



O-Ring 8,74x1,78 - N70

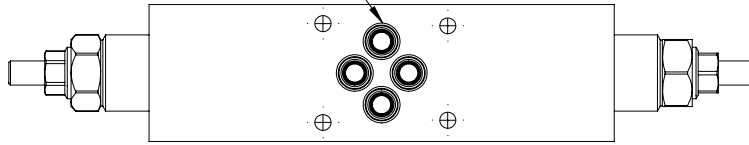

Ø 5,3 N°4 Holes

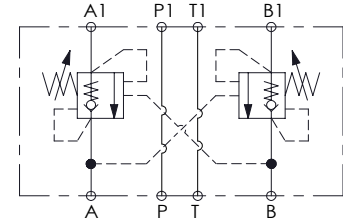
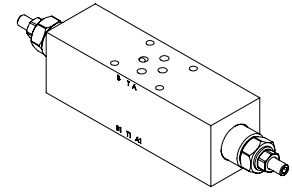
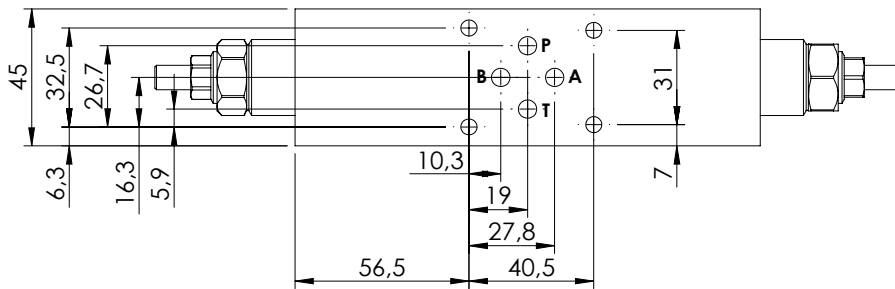
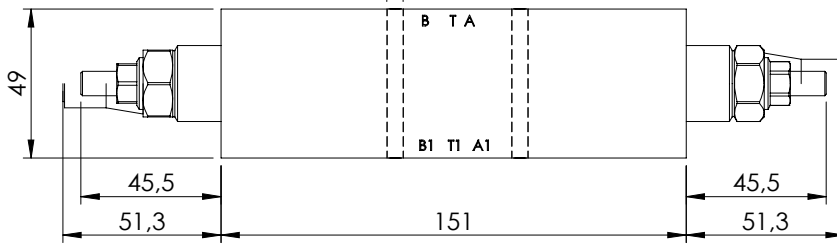

SPECIFICATIONS

Max. operating pressure:	350 bar
Rated flow:	60 l/min
Manifold:	Steel
Weight:	2,61 kg

SEALING CAP

Ordering code:
AT000020

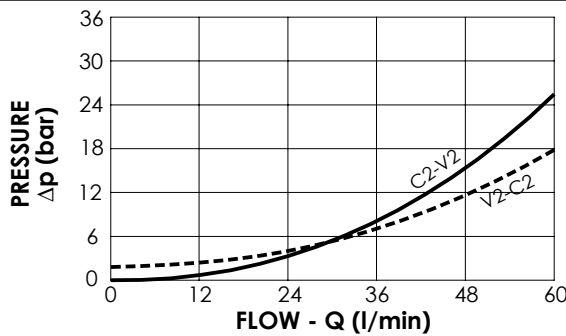
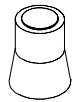

NOTES

Setting: at least 1.3 times the load induced pressure

ORDERING CODES

Quick code	Description	Pilot ratio	Main ports size	Standard setting (bar, Q=5 l/min)	Adjust. range (bar)	Pressure increase (bar/turn)
MB000929	MBDN-060-ATNR-04-N06-N350	4,2:1	A,B,P,T: CETOP 3	350	100-350	138
MB000774	MBDN-060-ATNR-04-N06-N200	4,2:1	A,B,P,T: CETOP 3	200	50-210	62

MODULAR VALVE FOR CETOP

MBDN-100-ZTNR

DOUBLE ACTING
CETOP 5



O-Ring 12,42x1,78 - N70

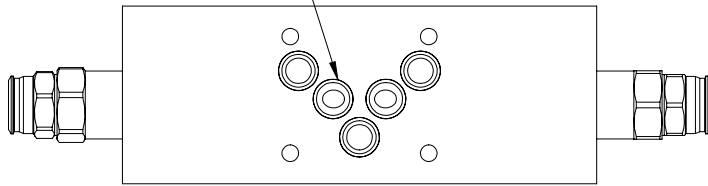

∅ 6,5 N°4 Holes

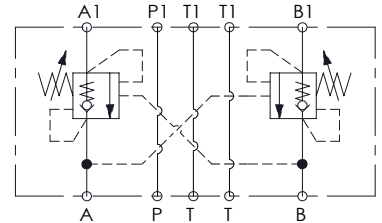
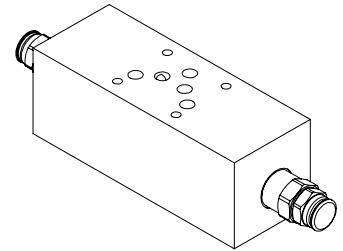
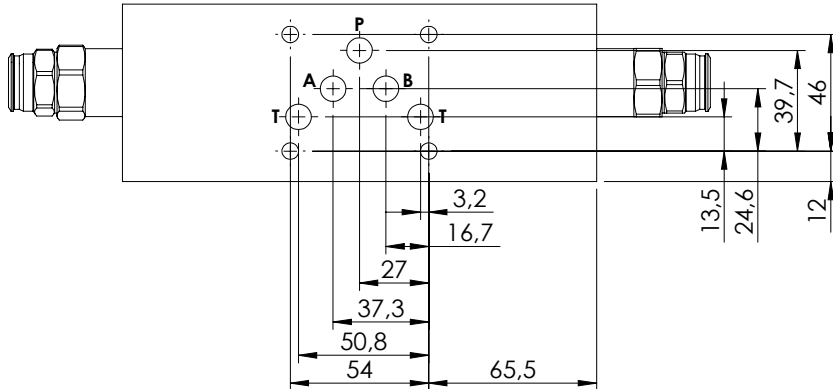
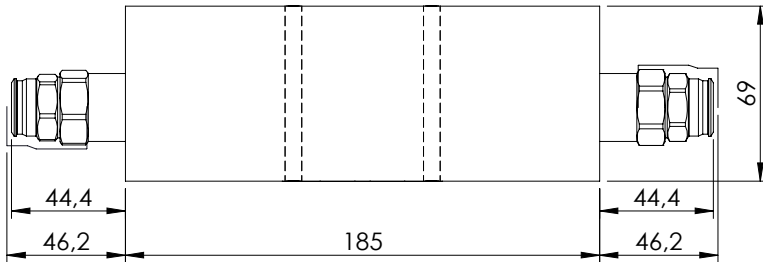

SPECIFICATIONS

Max. operating pressure:	350 bar
Rated flow:	100 l/min
Manifold:	Aluminium
Weight:	2,64 kg

SEALING CAP

Ordering code:
PT000243

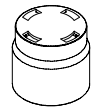

NOTES

Setting: at least 1.3 times the load induced pressure

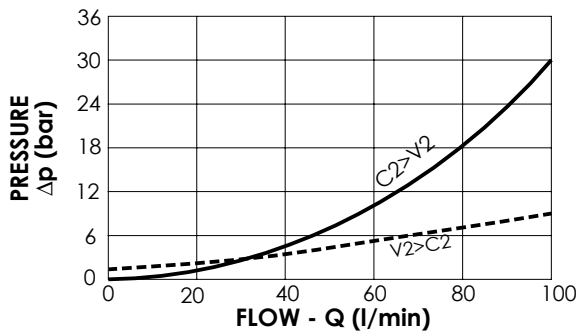

ORDERING CODES

Quick code	Description	Pilot ratio	Main ports size	Standard setting (bar, Q=5 l/min)	Adjust. range (bar)	Pressure increase (bar/turn)
MB000916	MBDN-100-ZTNR-04-N10-N350	4:1	A,B,P,T: CETOP 5	350	100-350	118

OVERCENTRE VALVE

MBDP-060-ZTNR

DOUBLE ACTING
CETOP 3



O-Ring 8,74x1,78 - N70

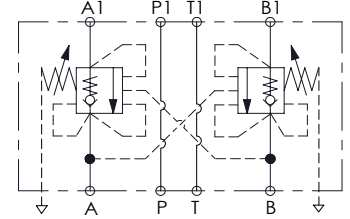
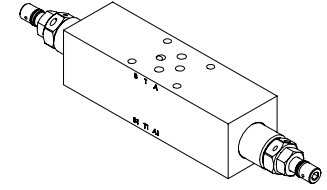
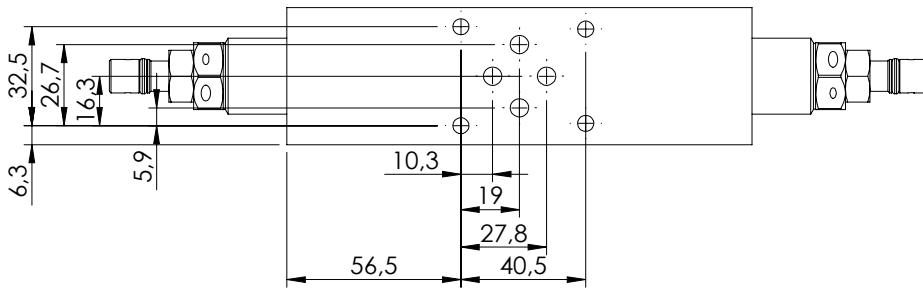
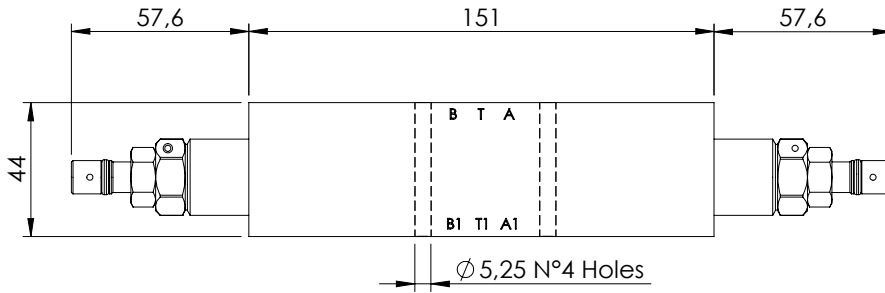
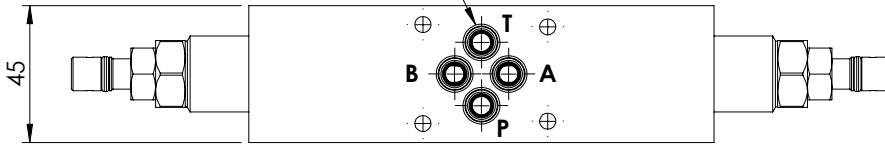

SPECIFICATIONS

Max. operating pressure:	350 bar
Rated flow:	60 l/min
Manifold:	Aluminium
Weight:	1,09 kg

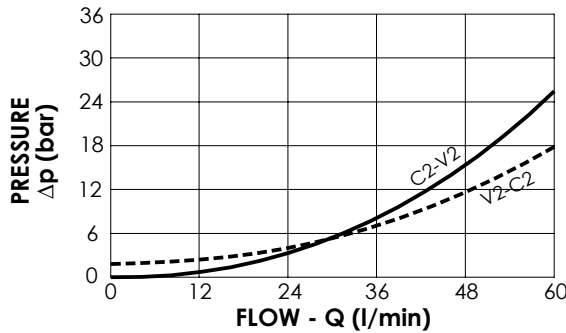

NOTES

Setting: at least 1.3 times the load induced pressure

ORDERING CODES

Quick code	Description	Pilot ratio	Main ports size	Standard setting (bar, Q=5 l/min)	Adjust. range (bar)	Pressure increase (bar/turn)
MB000454	MBDP-060-ZTNR-04-N06-N350	4,2:1	A,B,P,T: CETOP 3	350	100-350	166

MODULAR VALVE FOR CETOP

MBDT-100-ARNR

CETOP 5

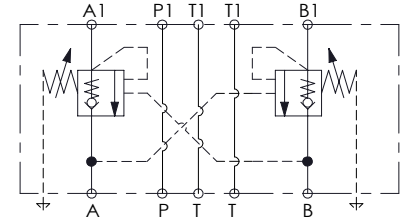
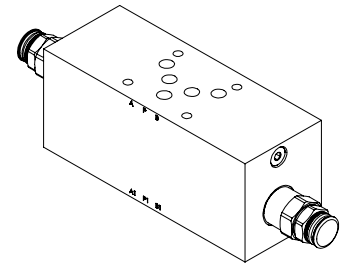
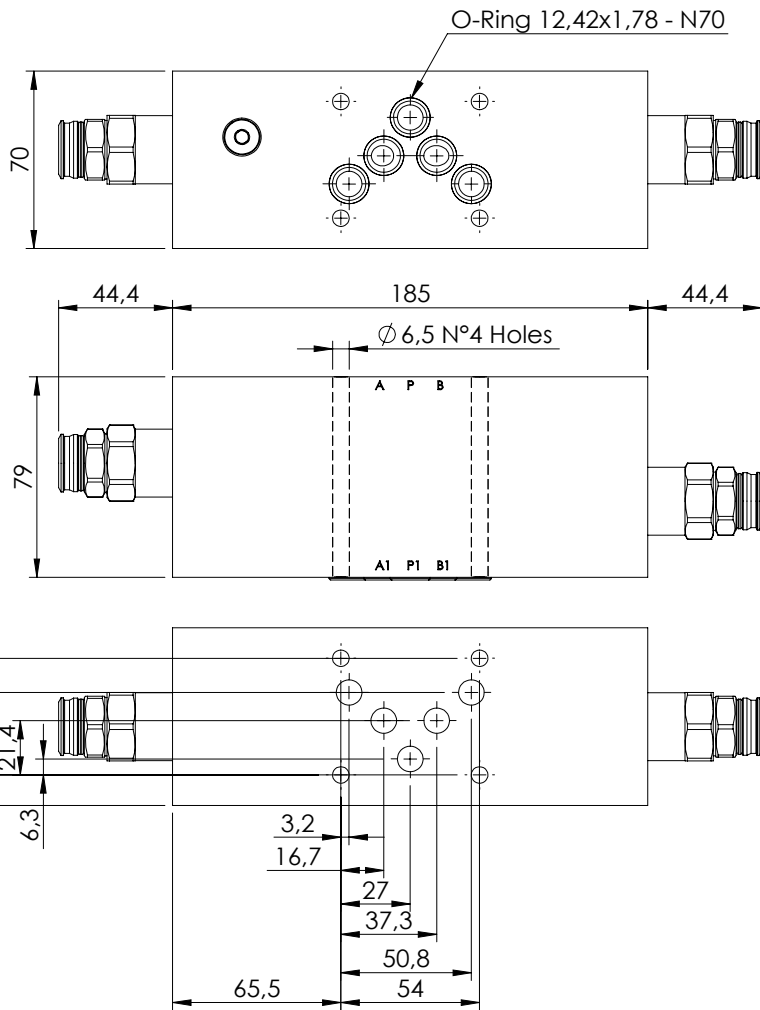

SPECIFICATIONS

Max. operating pressure:	350 bar
Rated flow:	100 l/min
Manifold:	Steel
Weight:	7,7 kg

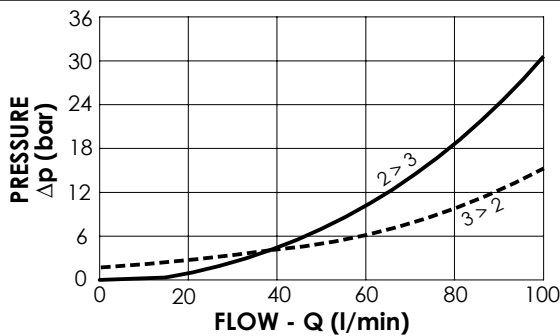

NOTES

Setting: at least 1.3 times the load induced pressure

ORDERING CODES

Quick code	Description	Pilot ratio	Main ports size	Standard setting (bar, Q=5 l/min)	Adjust. range (bar)	Pressure increase (bar/turn)
MB000930	MBDT-100-ATNR-04-N10-N350	3,8:1	A,B,P,T: CETOP 5	350	100-350	118



ATLANTIC
Fluid Tech

SECTION 19

Directional
Valves



1800-OILSOL
1800-645765

<https://oilsolutions.com.au/>

sales@oilsolutions.com.au

SECTION 19

DIRECTIONAL VALVES



Hydraulic scheme	Valve description	Valve type	Rated flow (l/min)	Max. pressure (bar)	Page
	EBN	On-off or proportional	30/60	210/320	19.10.000
	EBL	Load sensing, on-off or proportional	30/60	210/320	19.20.000
	EBP	Precompensated, load sensing, on-off or proportional	30/60	210/320	19.30.000
	Accessories	-	-	-	19.90.000



1800-OILSOL
1800-645765

<https://oilsolutions.com.au/>

sales@oilsolutions.com.au

EBN series

MONOBLOCK DIRECTIONAL VALVE ON-OFF OR PROPORTIONAL

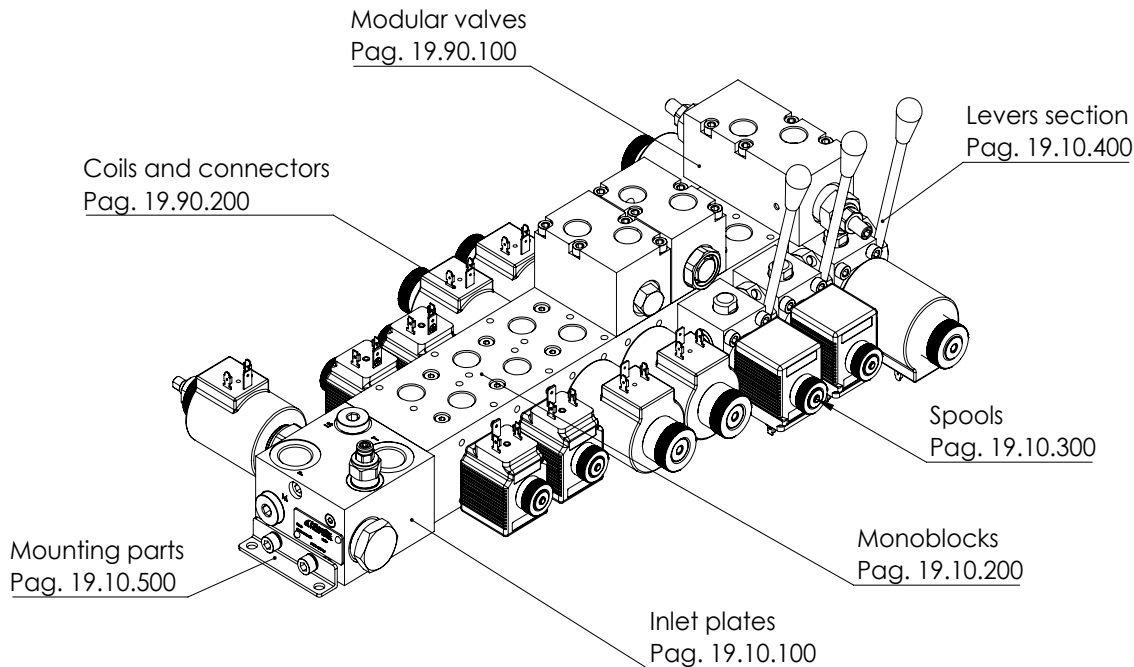

FEATURES

- Compact dimensions
- Low weight
- Custom spools
- Custom inlet blocks
- Sandwich valves for extra functions
- Cast iron monoblock and aluminum inlet block for standard applications
- High resistance cast iron monoblock and steel inlet block for high pressure systems
- Optional levers for manual operation
- No leak risk between sections
- Spools not under rod tension
- Zinc plated/anodized components for corrosion resistance

SPECIFICATION \ DESCRIPTION

MAXIMUM OPERATING PRESSURE	Steel inlet block: 320 bar (4500 PSI) Aluminium inlet block: 210 bar (3045 PSI)
MAXIMUM TANK PRESSURE	20 bar (290 PSI)
RATED FLOW	030 series: 30 l/min (7.9 GPM) 060 series: 60l/min (15.8 GPM)
COIL POWER	030 series: 26 W 060 series: 33 W
VOLTAGE	12 VDC, 24 VDC, others on request
COIL CONNECTOR	DIN43650, AMP Junior, Deutsch DT04-2P
PORTS	Inlet: G1/2", 1/2 JIS, 7/8-14 UNF-2B (SAE#10) Outlet: G3/8", 3/8 JIS, 3/4-16 UNF-2B (SAE#8)
OPERATING TEMPERATURE	NBR (ISO 1629) seals: -30, +80 °C FKM (ISO 1629) seals: -20, +110 °C
FILTRATION	ISO 4406:1999: class 19/17/14 NAS 1638: class 8
MOUNTING POSITION	No restrictions
MATERIAL	Spool body: cast iron Spool: hardened and grounded steel Inlet block: Aluminium or steel
SURFACE TREATMENT	Steel: zinc plating Aluminium: anodization

EBN series is a new directional valve that has innovative features in terms of performance, dimension, manufacturing reliability and customization. The valve consists in an inlet block flanged to a monoblock with spools. This construction gives the advantages of high flexibility in inlet block schemes, combined with the reliability and simplicity of monoblock spool valve construction, eliminating the risk of spools blocking due to overtightening of tie rods or the risk of leakage between sections. The spool monoblock is a 2 or 3 position, 4 ways, direct acting solenoid operated type. All sections have threaded ports at the top and removable plugs for tank connections to allow the installation of flanged blocks with additional functions like crossover reliefs, reliefs to tank, relief and anticavitations, counterbalance valves, P.O. checks, flow restrictors and flow regulators. All sections are equipped with standard push button override and they can be equipped with lever for manual use.

HOW ORDER IT

To order an assembled block, contact AFT sales network specifying the part numbers following page 19.90.900 path.

For special versions please contact AFT sales network.

To order the separate parts please refer to each catalogue page.



1800-OILSOL
1800-645765

<https://oilsolutions.com.au/>

sales@oilsolutions.com.au

EBN series - INLET SECTION

SFNL-060-ZNNN-01

**P, T PORTS
M PORTS**

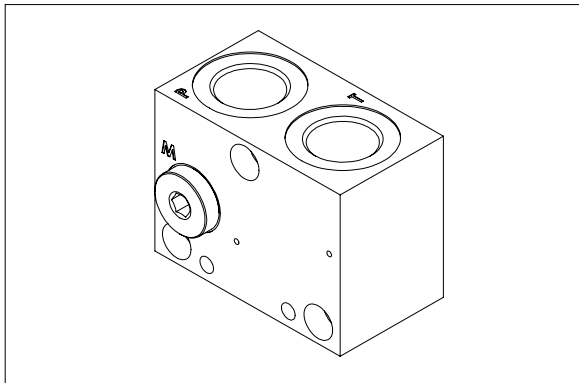

HYDRAULIC SCHEME

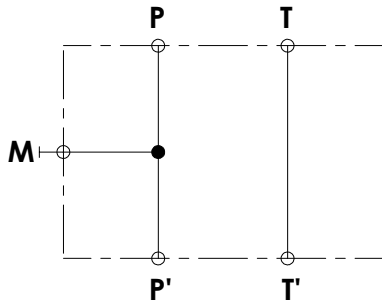

This inlet section is equipped with two thread ports (P, T) available in two different types G 1/2" or 3/4"-16 UNF plus a third threaded port M for pressure measuring available in G 1/4" or 7/16"-20. The manifold material is aluminium for applications up to 210 bar or zinc plated steel for applications up to 320 bar.

TECHNICAL DATA

Max pressure	210/320 bar
Rated flow	60 l/min
Hydraulic fluid	Mineral oil DIN 51 524
Fluid viscosity	10-500 mm ² /s
Fluid temperature	-25°C/75°C
Environment temperature	-25°C/60°C
Weight	0,3 Kg

PRESSURE DROP

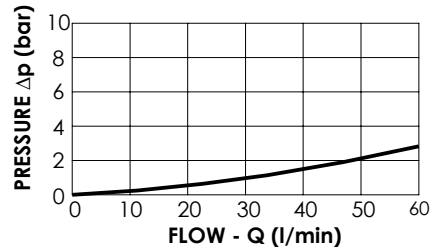

ORDERING DETAILS: SEPARATE ELEMENTS

SFNL-060 - *NNN-01-*-N**

*	MATERIAL TYPE
A	Steel zinc-plated (320 bar)
Z	Aluminium anodized (210 bar)

***	PORTS		
	P line	T line	M
G12	G 1/2"	G 1/2"	G 1/4"
U34	3/4"-16 UNF	3/4"-16 UNF	7/16"-20 UNF

QUICK CODE	
DESCRIPTION	CODE
SFNL-060-ZNNN-01-G12-N	SF000004

OVERALL DIMENSIONS

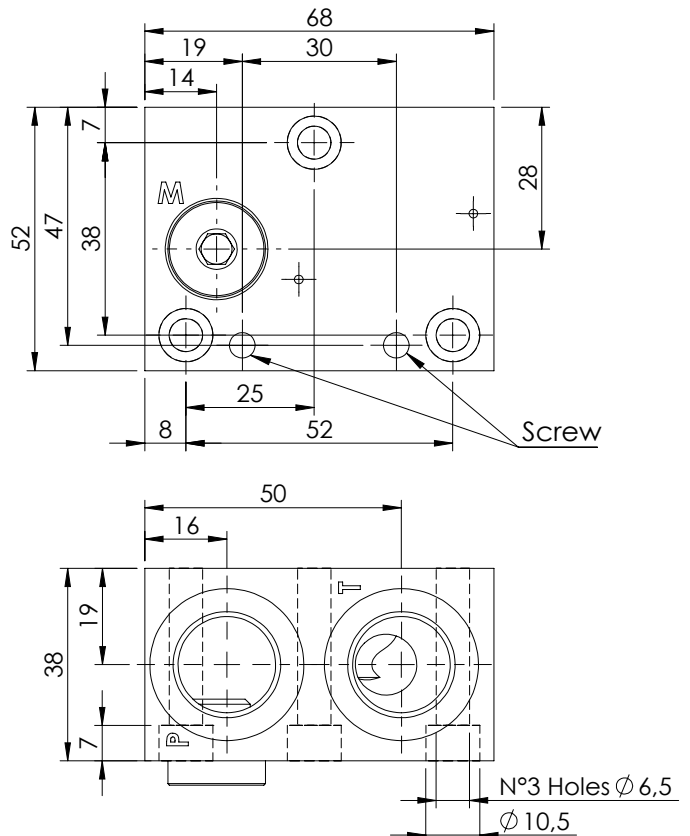

EBN series - INLET SECTION



SFNL-060-ZNNN-02

CHECK VALVE OPTIONS

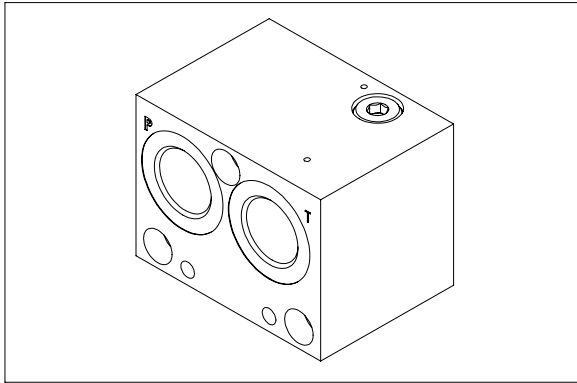

HYDRAULIC SCHEME

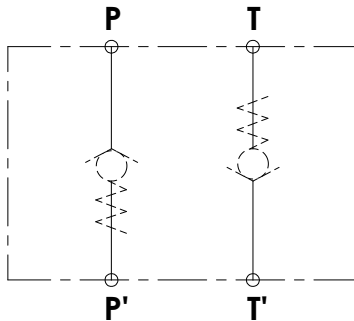

This inlet section is equipped with threaded ports (P, T) available in two different sizes G 1/2" or 3/4"-16 UNF, M ports is not available in this inlet section. The ports have extra threads to allow the installation of check valve on P and T ports. The manifold material is aluminium for applications up to 210 bar or zinc plated steel for applications up to 320 bar.

TECHNICAL DATA

Max pressure	210/320 bar
Rated flow	60 l/min
Hydraulic fluid	Mineral oil DIN 51524
Fluid viscosity	10-500 mm ² /s
Fluid temperature	-25°C/75°C
Environment temperature	-25°C/60°C
Weight	0,4 Kg

PRESSURE DROP

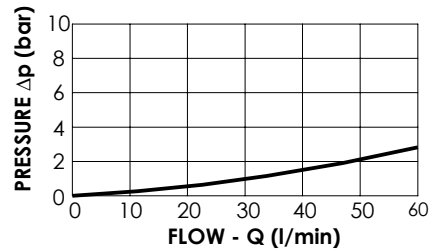

ORDERING DETAILS: SEPARATE ELEMENTS

SFNL-060- * NN * -02- * -N**

*	MATERIAL TYPE
A	Steel zinc-plated (320 bar)
Z	Aluminium anodized (210 bar)

*	CHECK VALVE OPTION
N	No check valve
D	Check valve on P e T ports
P	Check valve only P port
T	Check valve only T port

***	PORTS		
	P line	T line	M
G12	G 1/2"	G 1/2"	/
U34	3/4"-16 UNF	3/4"-16 UNF	/

QUICK CODE	
DESCRIPTION	CODE
SFNL-060-ZNNN-02-G12-N	SF000008
Check valve on P	CD000181
Check valve on T	CD000175

OVERALL DIMENSIONS

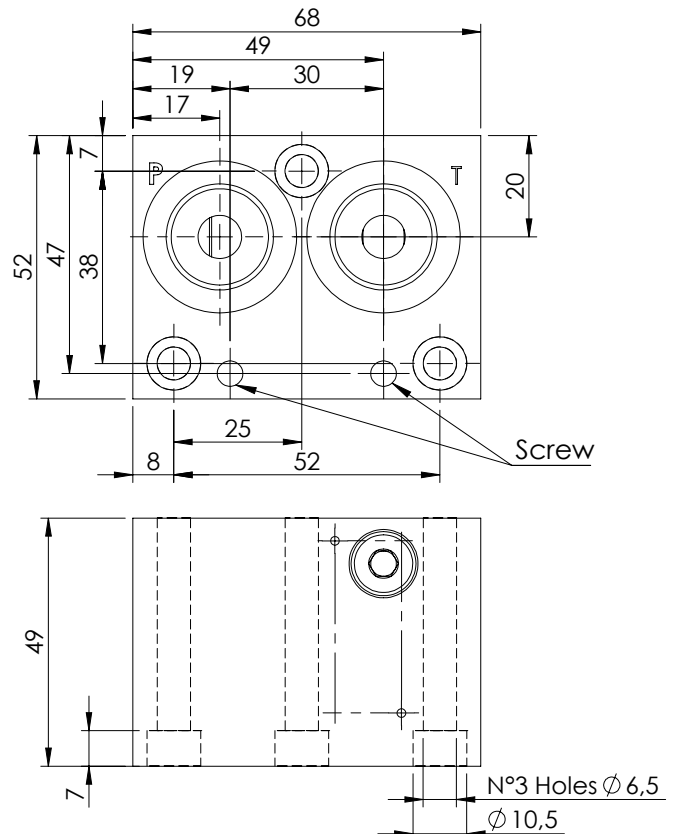

EBN series - INLET SECTION



SFNL-060-ZNNN-03

RELIEF VALVE M PORT

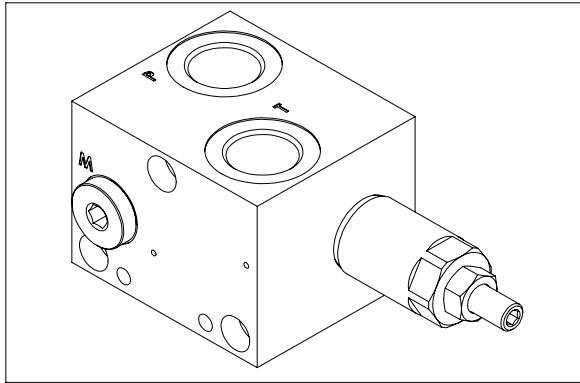

HYDRAULIC SCHEME

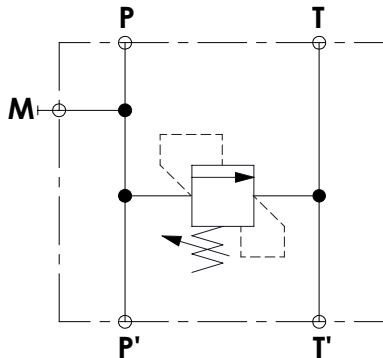

This inlet section is equipped with threaded ports (P, T) available in two different sizes G 1/2" or 3/4"-16 UNF, an M port is available in sizes G 1/4" or 9/16-18 UNF. It is also present a with relief valve with adjustable setting, the adjustment is made by socket screw; the max flow on the relief valve is 30 l/min. The manifold material is aluminium for applications up to 210 bar or zinc plated steel for applications up to 320 bar.

TECHNICAL DATA

Max pressure	210/320 bar
Rated flow	60 l/min
Hydraulic fluid	Mineral oil DIN 51524
Fluid viscosity	10-500 mm ² /s
Fluid temperature	-25°C/75°C
Environment temperature	-25°C/60°C
Weight	0,6 Kg

PRESSURE DROP

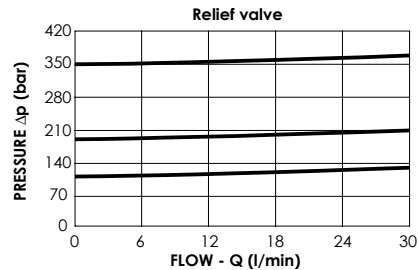

ORDERING DETAILS: SEPARATE ELEMENTS

SFNL-060-[*N*]-03-***-N

*	MATERIAL TYPE
A	Steel zinc-plated (320 bar)
Z	Aluminium anodized (210 bar)

*	SETTING RANGE
N	Max setting 210 bar (CP000083)
A	Max setting 110 bar (CP000084)
B	Max setting 350 bar (CP000082)

*	ADJUSTMENT OPTION
N	Screw adjustment
V	Knob adjustment

***	PORTS		
	P line	T line	M
G12	G 1/2"	G 1/2"	G 1/4"
U34	3/4"-16 UNF	3/4"-16 UNF	7/16"-20 UNF

QUICK CODE	
DESCRIPTION	CODE
SFNL-060-ZNNN-03-G12-N	SF000003

OVERALL DIMENSIONS

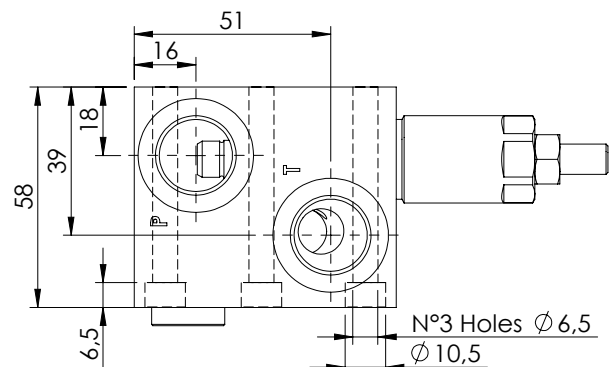
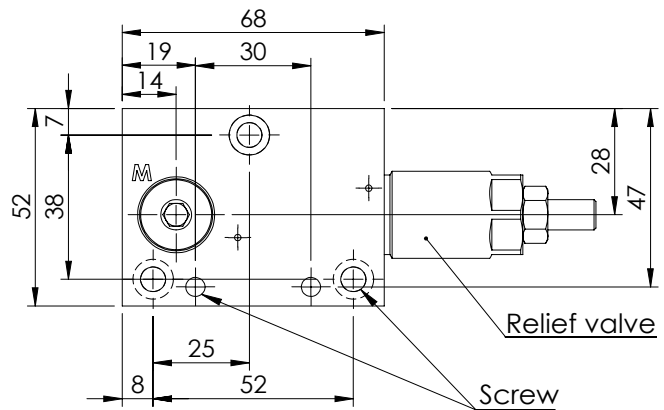

EBN series - INLET SECTION



SFNL-060-ZNNN-05

RELIEF VALVE UNLOADING VALVE

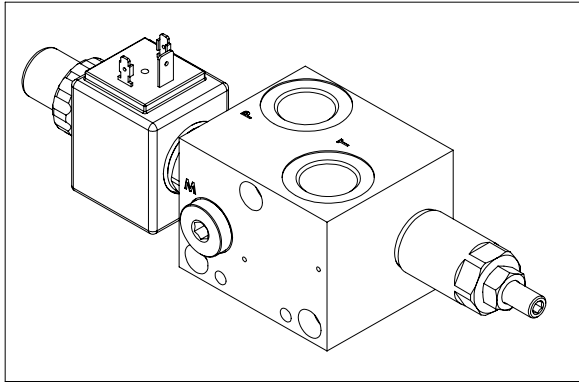

HYDRAULIC SCHEME

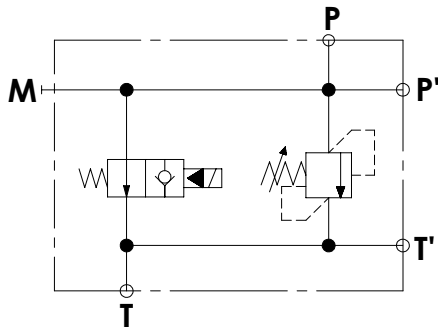

This inlet section is equipped with threaded ports (P, T) available in two different sizes G 1/2" or 3/4"-16 UNF, an M ports is available in sizes G 1/4" or 9/16-18 UNF. A with relief valve with adjustable setting protect from peak pressure; the max flow on the relief valve is 30 l/min. A solenoid valve normally open allow to unload the system and is equipped with manual override, max flow on the solenoid valve is 40 l/min. The manifold material is aluminium for applications up to 210 bar or zinc plated steel for applications up to 320 bar.

TECHNICAL DATA

Max pressure	210/320 bar
Rated flow	60 l/min
Hydraulic fluid	Mineral oil DIN 51524
Fluid viscosity	10-500 mm ² /s
Fluid temperature	-25°C/75°C
Environment temperature	-25°C/60°C
Weight	0,75 Kg

PRESSURE DROP

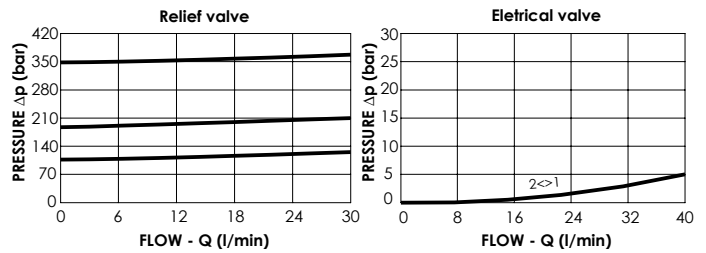

ORDERING DETAILS: SEPARATE ELEMENTS

SFNL-060-*N**-05-***-***N

*	MATERIAL TYPE
A	Steel zinc-plated (310 bar)
Z	Aluminium anodized (210 bar)

*	SETTING RANGE
N	Max setting 210 bar (CP000083)
A	Max setting 110 bar (CP000084)
B	Max setting 350 bar (CP000082)

*	ADJUSTMENT OPTION
N	Screw adjustment
V	Knob adjustment

***	PORTS
	P line T line M
G12	G 1/2" G 1/2" G 1/4"
U34	3/4"-16 UNF 3/4"-16 UNF 7/16"-20 UNF

*	VOLTAGE
	no coils
A	12 V dc
B	24 V dc

**	COILS TYPE
	no coils
HR	Hirschmann (ISO 4400 DIN 43650)
DT	Deutsch (DT04-2P)
AJ	Amp junior (AJ type)

QUICK CODE	
DESCRIPTION	CODE
SFNL-060-ZNNN-05-G12-N	SF000002
Unloading valve	CE000868

OVERALL DIMENSIONS

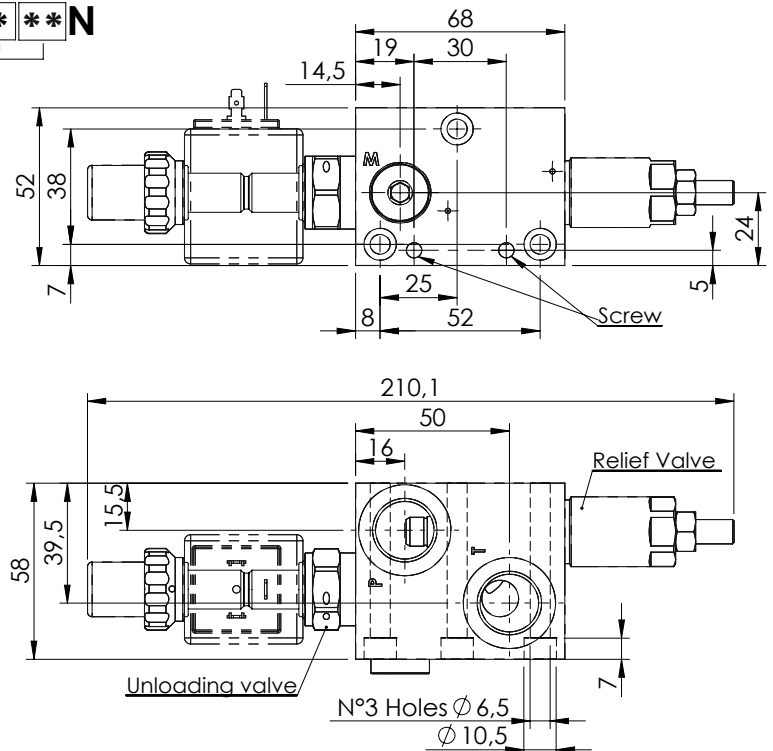

EBN series - INLET SECTION

SFNL-060-ZDNN-07

PROPORTIONAL COMPENSATED FLOW REGULATOR

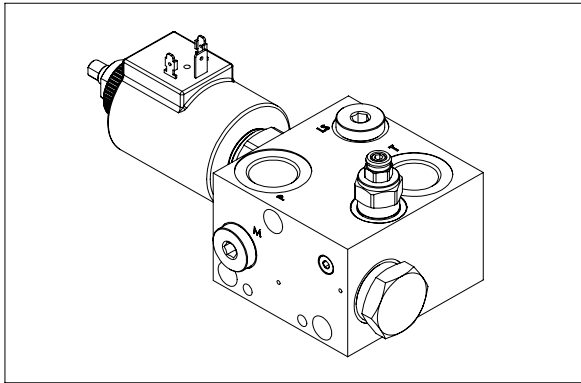

HYDRAULIC SCHEME

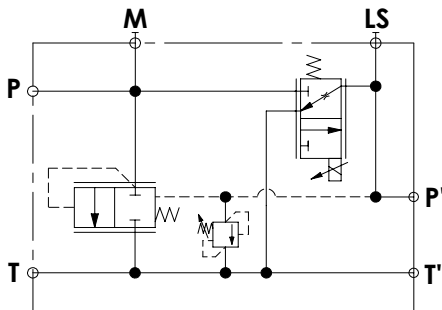

This inlet section is equipped with threaded ports (P, T) available in two different sizes G 1/2" or 3/4"-16 UNF, an M ports is available in sizes G 1/4" or 9/16-18 UNF; an LS port allows to measure of the load pressure.
 A proportional flow regulator with external flow compensator controls the metering, the maximum flow is 40 l/min; when not energized the compensator is unloading the flow.
 A relief valve with adjustable setting protect from peak of pressure.
 The manifold material is aluminium for applications up to 210 bar or zinc plated steel for applications up to 320 bar.

TECHNICAL DATA

Max pressure	210/320 bar
Rated flow	60 l/min
Hydraulic fluid	Mineral oil DIN 51524
Fluid viscosity	10-500 mm ² /s
Fluid temperature	-25°C/75°C
Environment temperature	-25°C/60°C
Weight	0,75 Kg

PROPORTIONAL FLOW REGULATOR CURVES

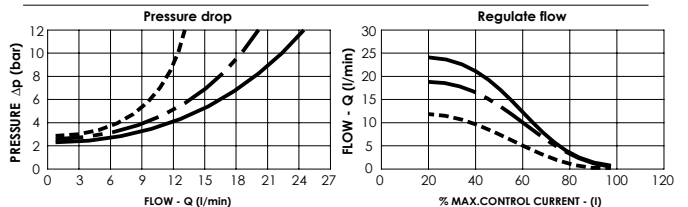

ORDERING DETAILS: SEPARATE ELEMENTS

SFNL-060-*D *-07-***-***N**

* MATERIAL TYPE	A Steel zinc-plated (320 bar)	Z Aluminium anodized (210 bar)
* RELIEF VALVE SETTING	N Max setting 210 bar (CP000029)	A Max setting 110 bar (CP000030)
	B Max setting 350 bar (CP000002)	
* ADJUSTMENT FLOW	N 30 l/min (CE000112)	A 20 l/min (CE000113)
	B 10 l/min (CE000111)	
*** PORTS	P line	T line
	G12 G 1/2"	G 1/2"
	U34 3/4"-16 UNF	7/16"-20 UNF
* VOLTAGE	no coils	
	A 12 V dc	
	B 24 V dc	
** COILS TYPE	no coils	
	HR Hirschmann (ISO 4400 DIN 43650)	
	DT Deutsch (DT04-2P)	
	AJ Amp junior (AJ type)	
QUICK CODE	DESCRIPTION	CODE
	SFNL-060-ZNNN-05-G12-N	SF000001

OVERALL DIMENSIONS

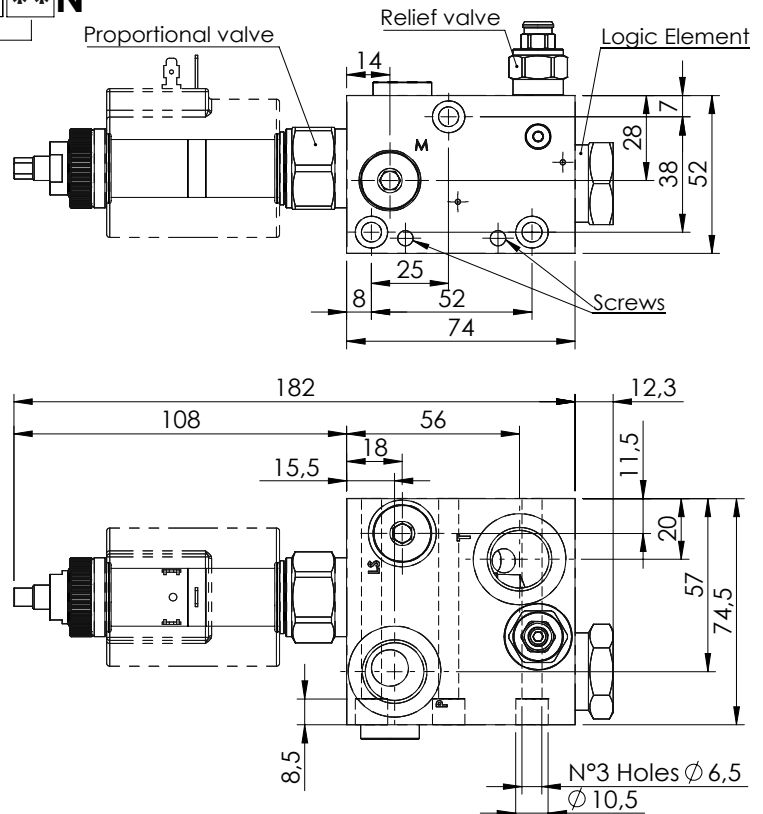

In LDNS/P-030-C plug are included in the manifold

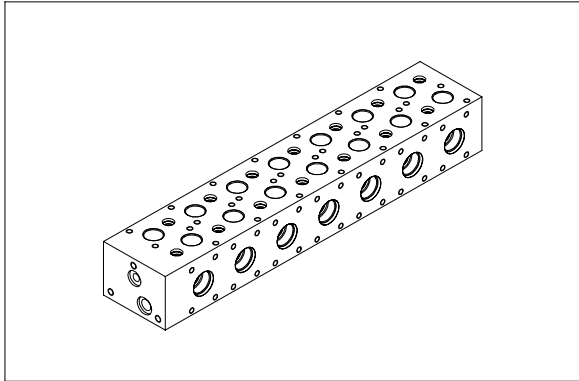

The monoblock valve can be ordered with a number of spool's section from 1 to 7, each section is equipped with side mounting holes for lever option and with treaded holes at the top for flangeable modular valve. There are also two removable plugs connecting to a T line to allow to flange special blocks.

The standard version has G 3/8" ports and can be supplied with top blocks with 9/16"-18 UNF (SAE6) or M16x1,5.

The manifold it is made with cast-iron and protected from corrosion with zinc-plating surface treatment.

The inlet face has 3 threaded holes to flange an inlet block that can be customized for each application, giving high flexibility to the project.

TECHNICAL DATA

Max pressure	320 bar
Rated flow	60 l/min
Material	Cast-iron
Surface treatment	Zinc-plated black
Weight for single section	1,6 kg
Wight for additional sections	+ 1 Kg each

ORDERING DETAILS: SEPARATE ELEMENTS

LDN * -060-NNNN - ** - ***

*	TYPE OF MANIFOLD
S	Series connection
P	Parallel connection

**	NUMBER OF SECTION
01	manifold with one section
02	manifold with two sections
03	manifold with three sections
04	manifold with four sections
05	manifold with five sections
06	manifold with six sections
07	manifold with seven sections

***	PORTS		
	P line	T line	M
G38	G 3/8"	G 3/8"	G 1/4"
U09	9/16"-18 UNF	9/16"-18 UNF	7/16"-20 UNF

QUICK CODE	
DESCRIPTION	CODE
LDNP-060-NNNN-01-G38	LD000156
LDNP-060-NNNN-02-G38	LD000155
LDNP-060-NNNN-03-G38	LD000147
LDNP-060-NNNN-04-G38	LD000146
LDNP-060-NNNN-05-G38	LD000154
LDNP-060-NNNN-06-G38	LD000153
LDNP-060-NNNN-07-G38	LD000157

MANIFOLD CONFIGURATIONS

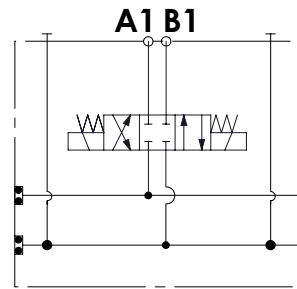

LDNP-060

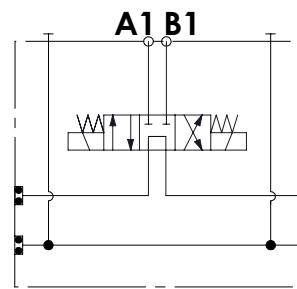

LDNS-060

MONOBLOCK PRESSURE DROP

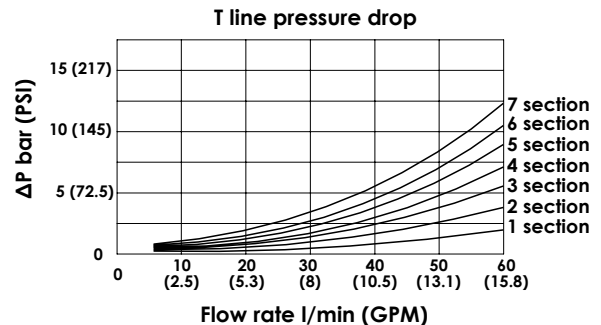
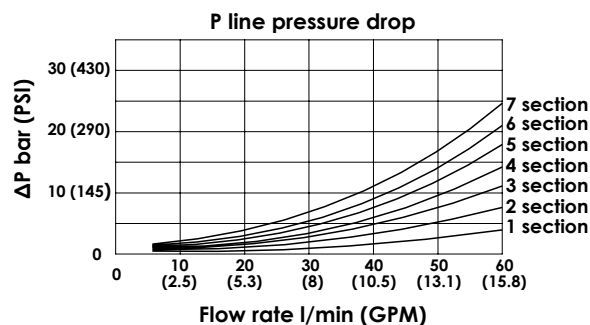

LDNS-060-NNNN

**CAST-IRON
MANIFOLD**

GAS VERSION

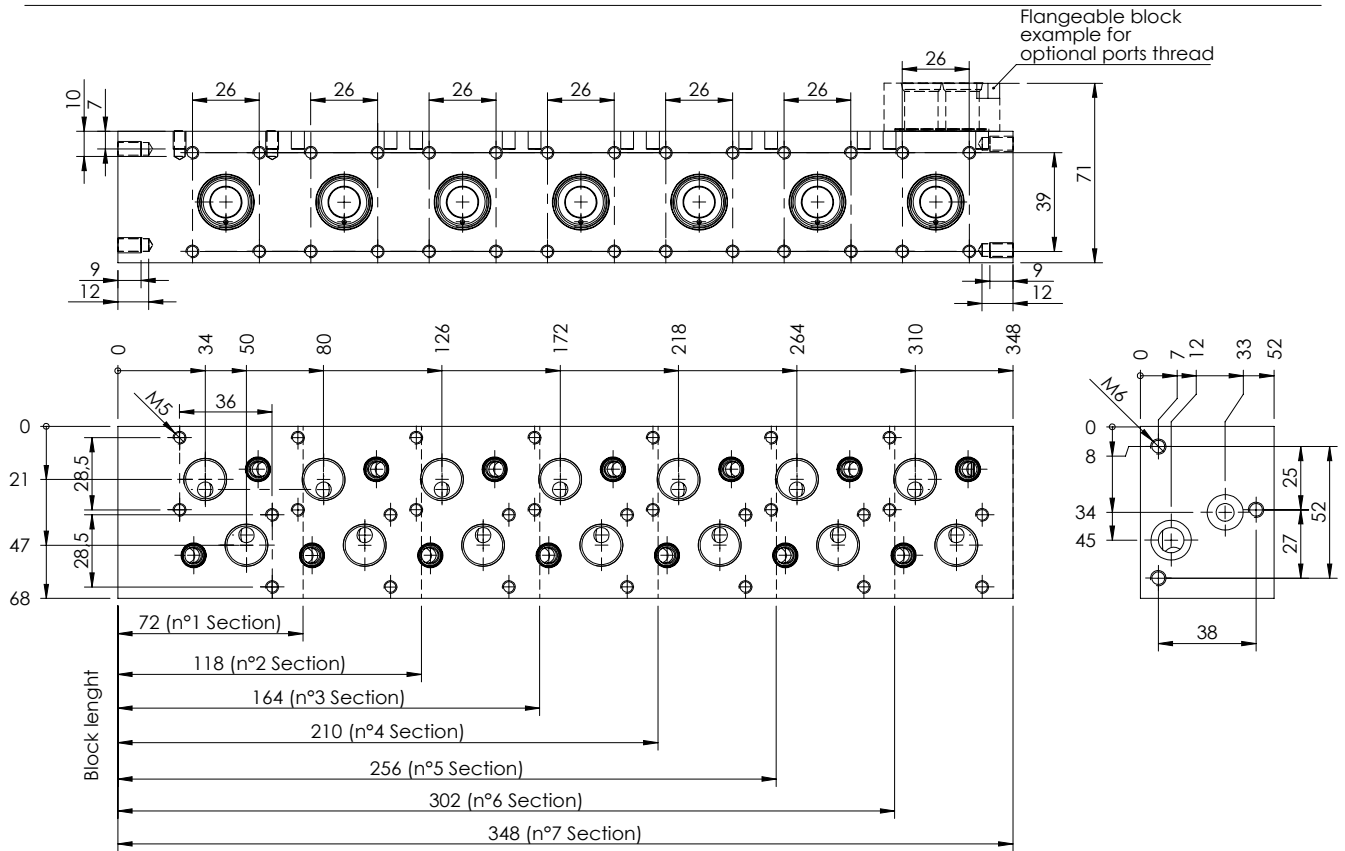

SAE VERSION

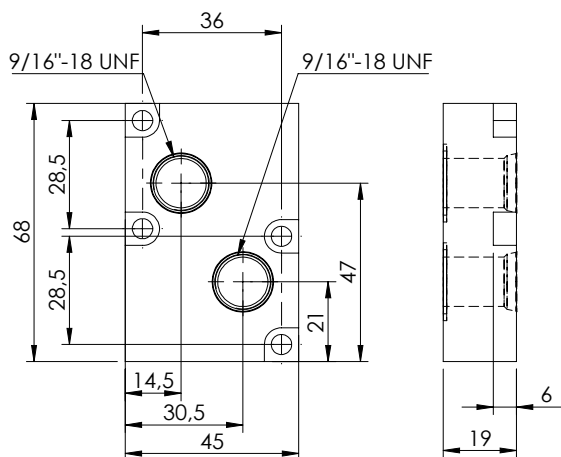

This top flangeable block transform the monoblock to a UNF version.

Quick code: MP000096

METRIC VERSION

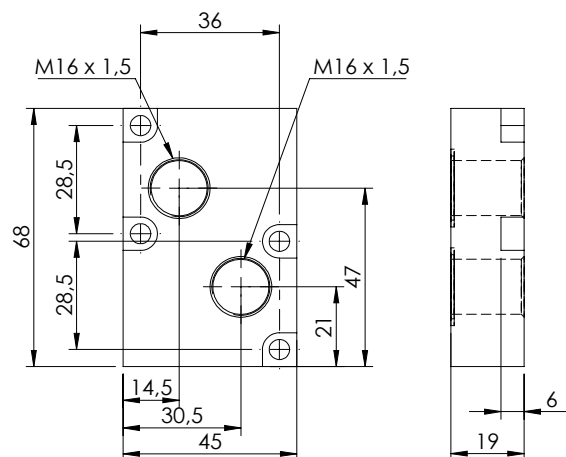

This top flangeable block transform the monoblock to a Metric version.

Quick code: MP000097

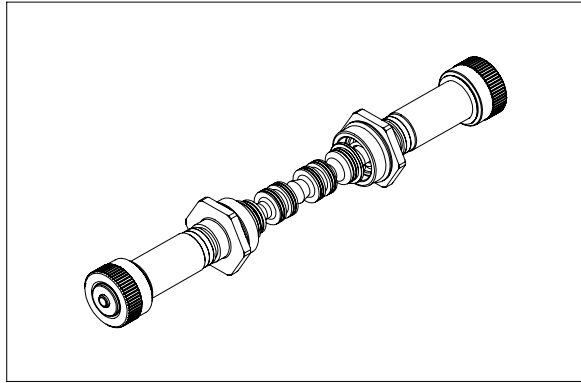

This spool group is rated for 30 lpm and for a maximum pressure of 320 bar; the spool is actuated by on off tubes and can be ordered with different hydraulic schemes. Each spools is interchangeable to give maximum flexibility and can be fit in all monoblock sections, changing spools require adequate training. The group is made by two tubes, one spool, two springs and mounting components.

TECHNICAL DATA

Max pressure	320 bar
Rated flow	30 l/min
Duty cycle	100 % ED
Hydraulic fluid	Mineral oil DIN 51 524
Fluid viscosity	10/500 mm ² /s
Fluid temperature	-25°C/75°C
Environment temperature	-25°C/60°C
Weight with one solenoid	0,15 Kg
Weight with two solenoid	0,12 kg

ORDERING DETAILS: SEPARATE ELEMENTS

SH* *- 030 - NN** - ** -321- * **N

* OVERRIDE TYPE	
N	Standard
P	Push
V	Screw

* SECTION TYPE	
E	Solenoid operated
L	Solenoid operated plus lever operated
M	Lever operated

** ACTUATION TYPE	
ON	On/Off
SS	Soft shift

** SPOOL TYPE	
...	See table n°1

* VOLTAGE	
	no coils
A	12 V dc
B	24 V dc

** COILS TYPE	
	no coils
HR	Hirschmann (ISO 4400 DIN 43650)
DT	Deutsch (DT04-2P)
AJ	Amp junior (AJ type)

QUICK CODE	
DESCRIPTION	CODE
SHNE-030-NNON-46-321	
SHNE-030-NNON-10-321	
SHNE-030-NNON-07-321	

HYDRAULIC SYMBOLS

Table n°1

SPOOL CODE	HYDRAULIC SCHEME	TRANSITORY POSITION	
46			
10			
07			
SPOOL CODE	HYDRAULIC SCHEME	TRANSITORY POSITION	
a	b	a	b
23			
21			
22			
17			
18			

OVERRIDE TYPE

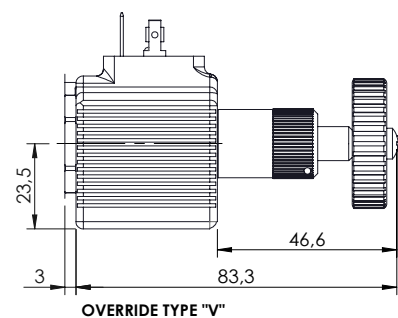
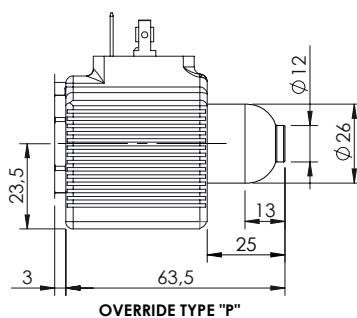
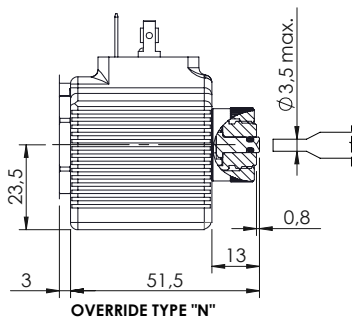

SHNE-030-NNON

30 L/MIN
SOLENOID VALVE

PERFORMANCE LIMITS CURVES - STANDARD SECTION

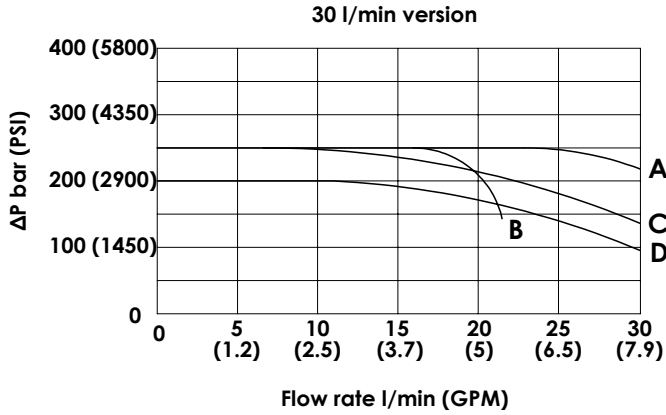

Spool type	Performance limits curve
46	A
10	A
07	B
23	A
21	A
22	A
17	C
18	D

The tests are carried out with hot solenoids, powered with 90% of nominal voltage, with 50 °C fluid temperature. The fluid used is mineral oil having a viscosity of 46 mm² / s @ 40 °C. The values in the diagram refer to tests carried out with flow simultaneously in both directions (P > A, B > T). In cases of schemes 4/2 or 4/3 used with the flow in one direction only the performance can change.

PRESSURE DROP CURVES - STANDARD SECTION

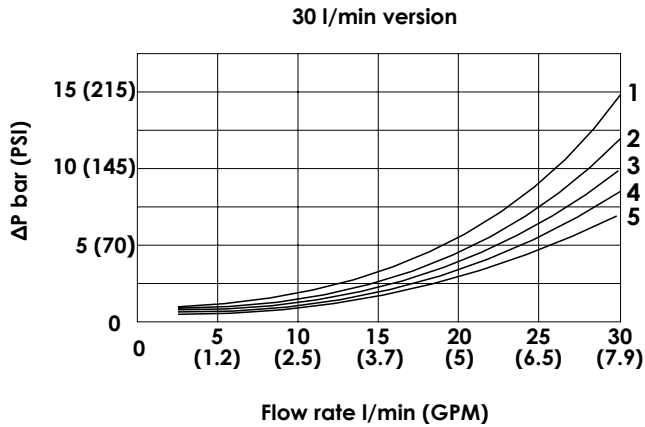

Spool type	Pressure drop curve				
	P>A	P>B	A>T	B>T	P>T
46	3	3	4	4	/
10	3	3	5	5	/
07	2	2	1	1	2
23	/	3	4	/	/
21	/	3	5	/	/
22	2	/	/	1	/
17	/	3	4	/	/
18	/	2	3	/	/

The diagram shows the performance limit curve of standard section. The fluid used is mineral oil viscosity 46 mm²/s at 40 °C ; the tests are performed at a 40 °C temperature

OVERALL DIMENSION - STANDARD SECTION

In case of top modular valve MA or MC type installation the coil connection can be faced to the top or to the bottom of the block. (See modular valve section)

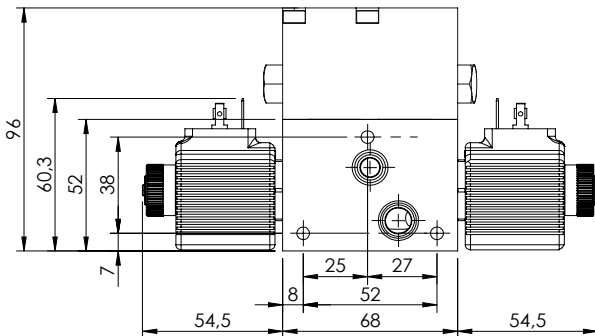

In case of top modular valve MB, KE and KF type installation the coil connection can be faced only to the bottom of the block. (See modular valve section)

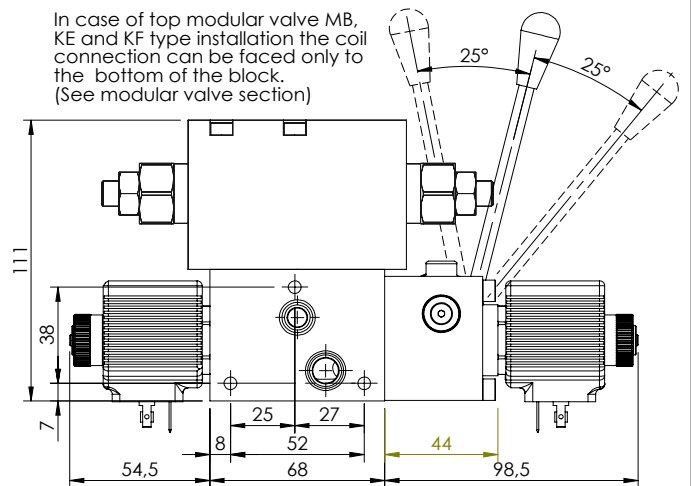

SHNE-060-NNON

60 L/MIN
SOLENOID VALVE

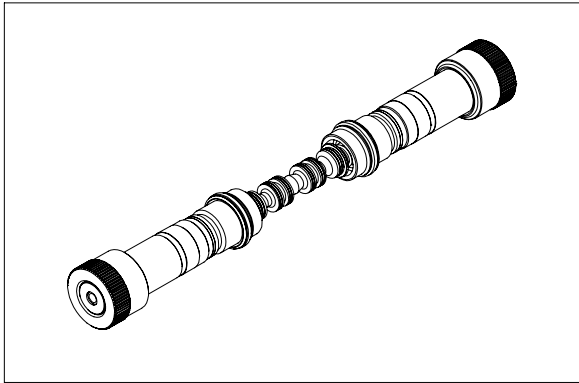

This spool group is rated for 60 lpm and for a maximum pressure of 320 bar; the spool is actuated by on off tubes and can be ordered with different hydraulic schemes. Each spools is interchangeable to give maximum flexibility and can be fit in all monoblock sections, changing spools require adequate training. The group is made by two tubes, one spool, two springs and mounting components.

TECHNICAL DATA

Max pressure	320 bar
Rated flow	60 l/min
Duty cycle	100 % ED
Hydraulic fluid	Mineral oil DIN 51524
Fluid viscosity	10/500 mm ² /s
Fluid temperature	-25°C/75°C
Environment temperature	-25°C/60°C
Weight with one solenoid	0,2 Kg
Weight with two solenoid	0,4 kg

ORDERING DETAILS: SEPARATE ELEMENTS

SH** - 060 - NN** - ** - 321 - ** * N

*	VERRIDE TYPE
N	Standard
P	Push
V	Screw

*	SECTION TYPE
E	Solenoid operated
L	Solenoid operated plus lever operated
M	Lever operated

**	ACTUATION TYPE
ON	On/Off
SS	Soft shift

**	SPOOL TYPE
...	See table n°1

*	VOLTAGE
	no coils
A	12 V dc
B	24 V dc

**	COILS TYPE
	no coils
HR	Hirschmann (ISO 4400 DIN 43650)
DT	Deutsch (DT04-2P)
AJ	Amp junior (AJ type)

QUICK CODE	
DESCRIPTION	CODE
SHNE-060-NNON-46-321	
SHNE-060-NNON-10-321	
SHNE-060-NNON-07-321	

HYDRAULIC SYMBOLS

Table n°1

SPOOL CODE	HYDRAULIC SCHEME	TRANSITORY POSITION	
46			
10			
07			
SPOOL CODE	HYDRAULIC SCHEME	TRANSITORY POSITION	
a	b	a	b
23			
21			
22			
17			
18			

VERRIDE TYPE

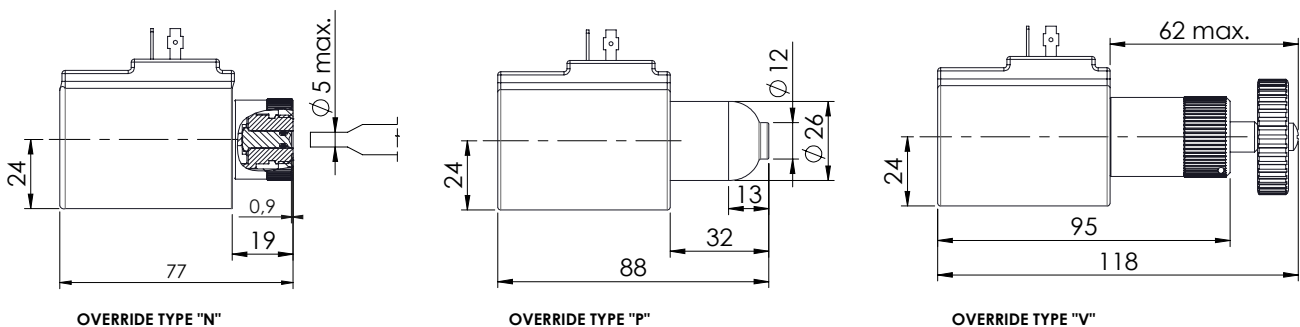

SHNE-060-NNON

60 L/MIN SOLENOID VALVE

PERFORMANCE LIMIT CURVES - STANDARD SECTION

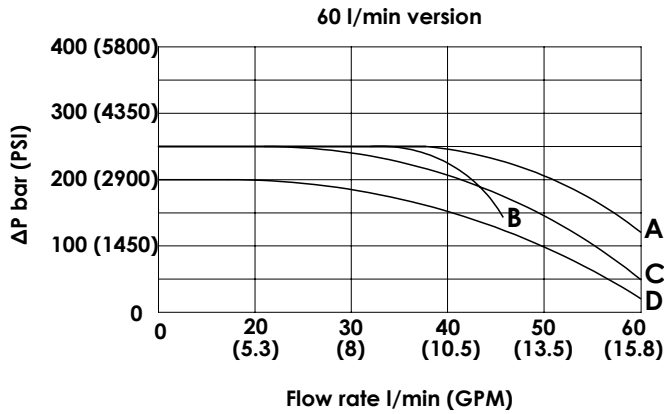

Spool type	Performance limits curve
46	A
10	A
07	B
23	A
21	A
22	A
17	C
18	D

The tests are carried out with hot solenoids, powered with 90 % of nominal voltage, with 50 °C fluid temperature. The fluid used is mineral oil having a viscosity of 46 mm² / s @ 40 °C.

The values in the diagram refer to tests carried out with flow simultaneously in both directions (P > A, B > T).

In cases of schemes 4/2 or 4/3 used with the flow in one direction only the performance can change.

PRESSURE DROP CURVES - STANDARD SECTION

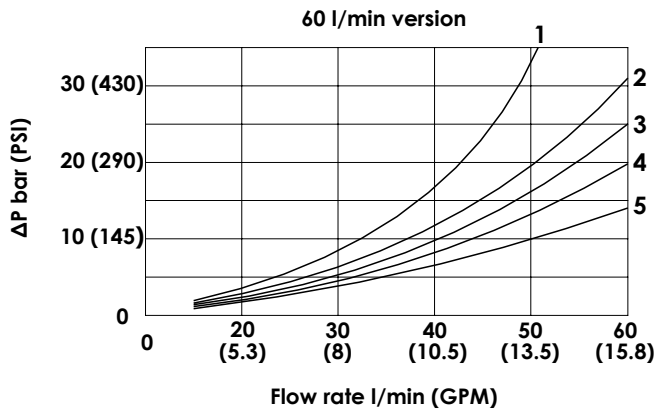

Spool type	Pressure drop curve				
	P>A	P>B	A>T	B>T	P>T
46	3	3	4	4	/
10	3	3	5	5	/
07	2	2	1	1	2
23	/	3	4	/	/
21	/	3	5	/	/
22	2	/	/	1	/
17	/	3	4	/	/
18	/	2	3	/	/

The diagram shows the performance limit curve of standard section. The fluid used is mineral oil viscosity 46 mm²/s at 40 °C ; the tests are performed at a 40 °C temperature

OVERALL DIMENSION - STANDARD SECTION

In case of top modular valve MA or MC type installation the coil connection can be faced to the top or to the bottom of the block. (See modular valve section)

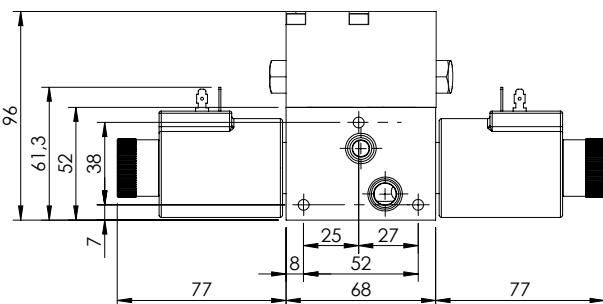

In case of top modular valve MB, KE and KF type installation the coil connection can be faced only to the bottom of the block. (See modular valve section)

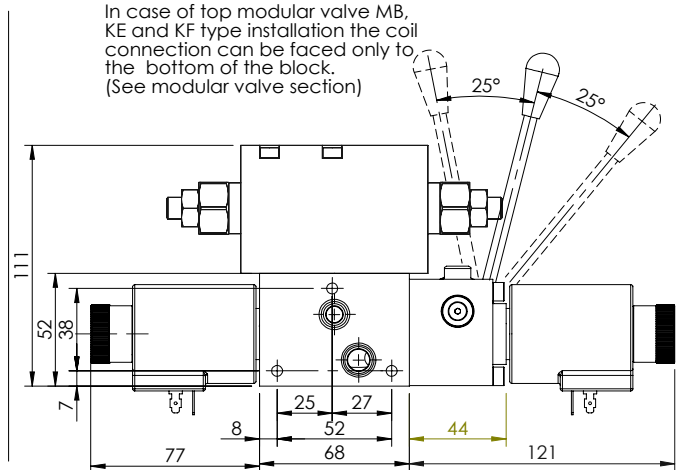

SHNE-050-NNPR

**50 L/MIN
PROPORTIONAL
SOLENOID VALVE**

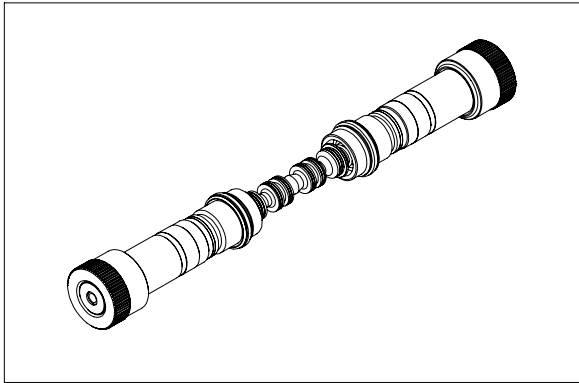

This spool group is rated for 50 lpm and for a maximum pressure of 320 bar; the spool is actuated by proportional tubes and can be ordered with different hydraulic schemes. Each spools is interchangeable to give maximum flexibility and can be fit in all monoblock sections, changing spools require adequate training. The group is made by two tubes, one spool, two springs and mounting components.

TECHNICAL DATA

Max pressure	320 bar
Rated flow	50 l/min
Duty cycle	100 % ED
Max current	1.76A (12 V dc) 0.88A (24 V dc)
Hydraulic fluid	Mineral oil DIN 51524
Fluid viscosity	10/500 mm
Fluid temperature	-25°C/75°C
Environment temperature	-25°C/60°C
Weight with one solenoid	0,2 Kg
Weight with two solenoid	0,4 kg

ORDERING DETAILS: SEPARATE ELEMENTS

SH - 0**-NNPR-**-321-***N**

*	VERRIDE TYPE
N	Standard
P	Push
V	Screw

*	SECTION TYPE
E	Solenoid operated
L	Solenoid operated plus lever operated
M	Lever operated

*	SPOOL FLOW
20	20 l/min at 12 bar - 10 l/min at 6 bar
35	35 l/min at 12 bar - 20 l/min at 6 bar
50	50 l/min at 12 bar - 30 l/min at 6 bar

**	
...	See table n°1

*	VOLTAGE
	no coils
A	12 V dc
B	24 V dc

**	COILS TYPE
	no coils
HR	Hirschmann (ISO 4400 DIN 43650)
DT	Deutsch (DT04-2P)
AJ	Amp junior (AJ type)

QUICK CODE	
DESCRIPTION	CODE
SHNE-030-NNPR-59-321	
SHNE-030-NNPR-55-321	

HYDRAULIC SYMBOLS

Table n°1

SPOOL CODE	HYDRAULIC SCHEME		TRANSITORY POSITION		
	a	b	a	b	
59					
55					
SPOOL CODE	HYDRAULIC SCHEME		TRANSITORY POSITION		
a	b	a	b	a	b

For single solenoid operation please contact AFT sales network.

VERRIDE TYPE

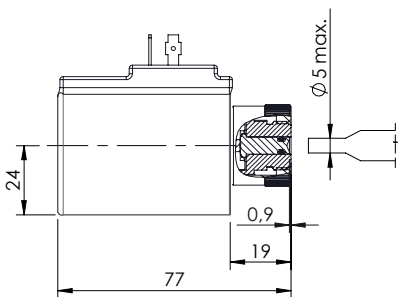

VERRIDE TYPE "N"

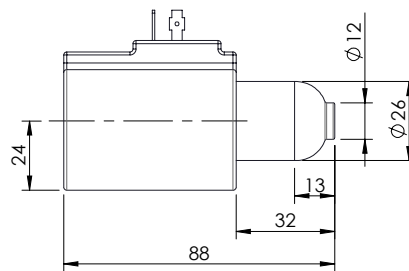

VERRIDE TYPE "P"

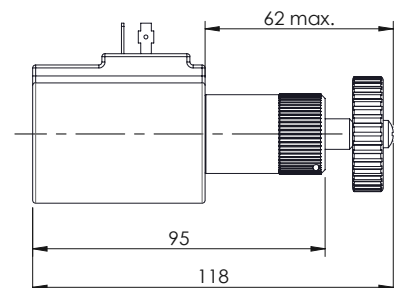

VERRIDE TYPE "V"

SHNE-050-NNPR

50 L/MIN
PROPORTIONAL
SOLENOID VALVE

FLOW DIAGRAM - 050

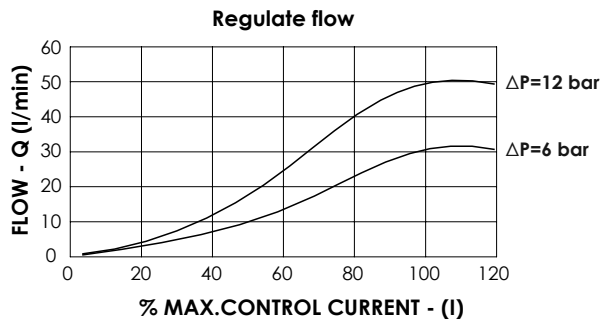

REGULATION DIAGRAM - 050

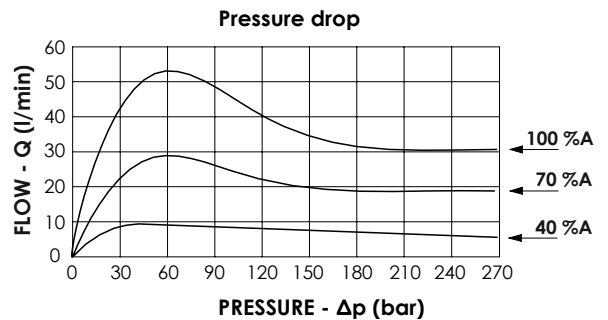

FLOW DIAGRAM - 035

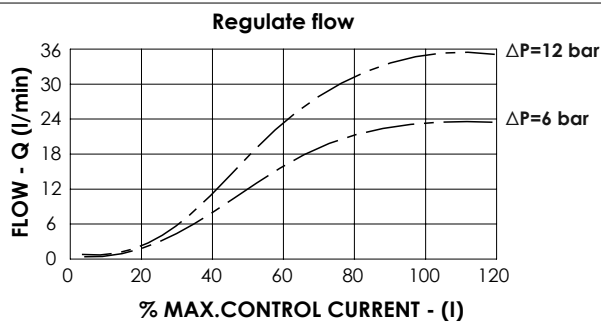

REGULATION DIAGRAM - 035

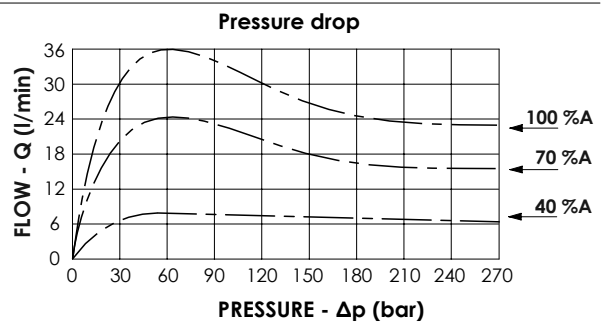

FLOW DIAGRAM - 020

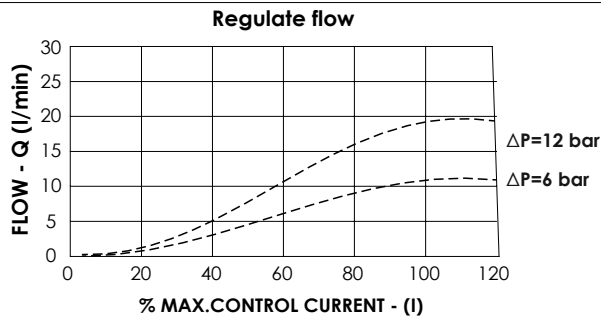

REGULATION DIAGRAM - 020

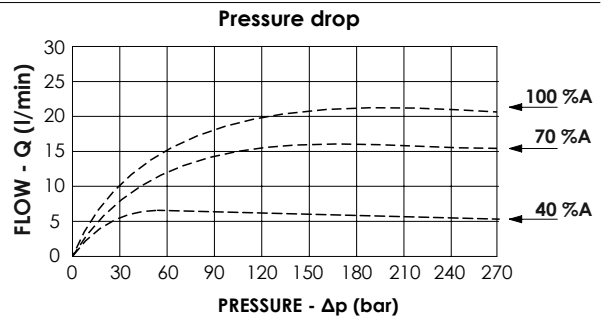

Spool type:
-10 -----
-20 -----
-30 -----

The diagram shows the performance limit curve of a standard section. The fluid used is mineral oil with viscosity of 46 mm²/s @ 40 °C ; the tests are performed at a 40 °C temperature.

OVERALL DIMENSION - STANDARD SECTION

In case of top modular valve MA or MC type installation the coil connection can be faced to the top or to the bottom of the block. (See modular valve section)

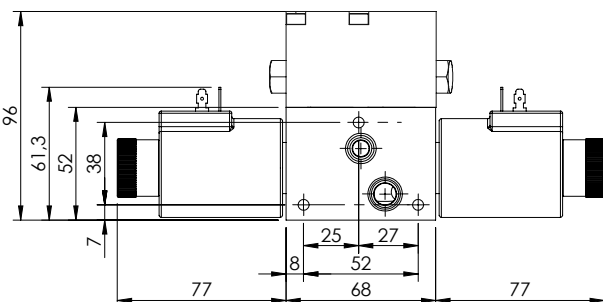

In case of top modular valve MB, KE and KF type installation the coil connection can be faced only to the bottom of the block. (See modular valve section)

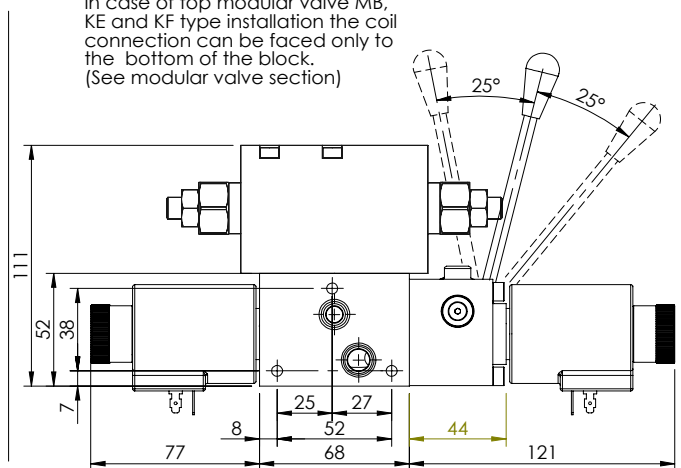

SHNE-030-POPR

30 L/MIN
PROPORTIONAL FLOW
UNLOADING

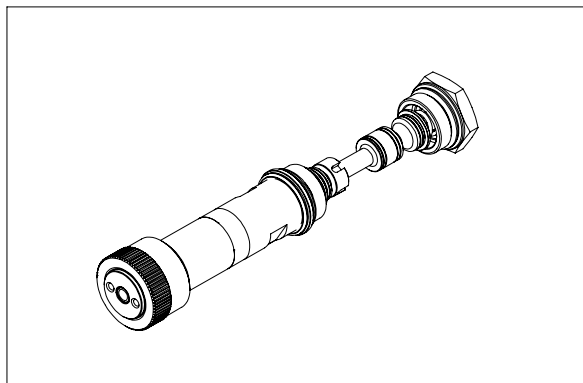

The solenoid valve can be ordered with 3 types of ports for connection nipples, G 3/8" 9/16"-18 UNF (SAE6) and M16x1, 5. Spool actuation is electrical and the center position is maintained through centering springs with calibrated length, upon termination of the solenoid action, springs immediately reposition the cursor in the central position. The solenoids are only available in the continuous current (the most common strains); the coil will be supply with terminals DIN 43650 ISO 4400 (for standard versions). The valve have cast iron body with black galvanizing surface treatment with sealant.

TECHNICAL DATA

Max pressure	320 bar
Rated flow	25 l/min
Duty cycle	100 % ED
Max current	1.76A (12 V dc) 0.88A (24 V dc)
Hydraulic fluid	Mineral oil DIN 51524
Fluid viscosity	10/500 mm
Fluid temperature	-25°C/75°C
Environment temperature	-25°C/60°C
Weight with one solenoid	2 Kg
Weight with two solenoid	2,5 kg

ORDERING DETAILS: SEPARATE ELEMENTS

SH** - 0** - POPR - ** - 321 - ** *N

*	VERRIDE TYPE
N	Standard
P	Push
V	Screw

*	SECTION TYPE
E	Solenoid operated
L	Solenoid operated plus lever operated
M	Lever operated

**	SPOOL FLOW
10	12 l/min at 10 bar
20	18 l/min at 10 bar
30	25 l/min at 10 bar

**	ROPORTIONAL TYPE
88	Not compensated

*	VOLTAGE
	no coils
A	12 V dc
B	24 V dc

**	COILS TYPE
	no coils
HR	Hirschmann (ISO 4400 DIN 43650)
DT	Deutsch (DT04-2P)
AJ	Amp junior (AJ type)

QUICK CODE	
DESCRIPTION	CODE
SHNE-030-POPR-88-321	
SHNE-020-POPR-88-321	
SHNE-010-POPR-88-321	

TECHNICAL FEATURES

Spool Flow	Rated flow with 10 bar ΔP	Maximum flow	Max. operating pressure
10	10	12	320
20	16	18	320
30	23	28	320

HYDRAULIC SYMBOLS

Table n°1

SPOOL CODE	HYDRAULIC SCHEME	TRANSITORY POSITION
88		

OVERRIDE TYPE

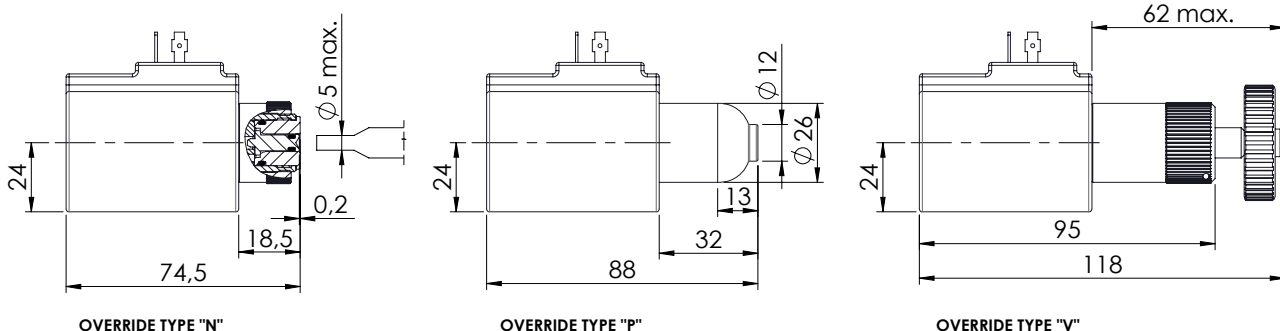

SHNE-030-PRPO

30 L/MIN
PROPORTIONAL FLOW
UNLOADING

FLOW DIAGRAM - 030

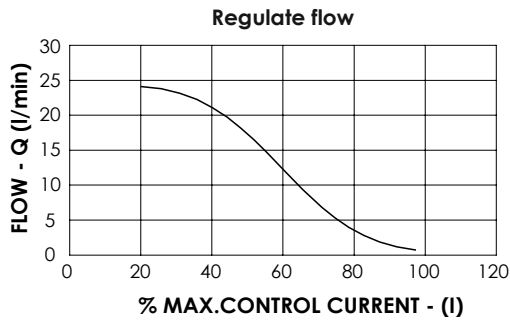

PRESSURE DROP DIAGRAM - 030

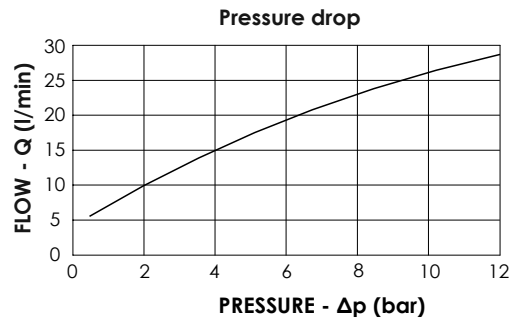

FLOW DIAGRAM - 020

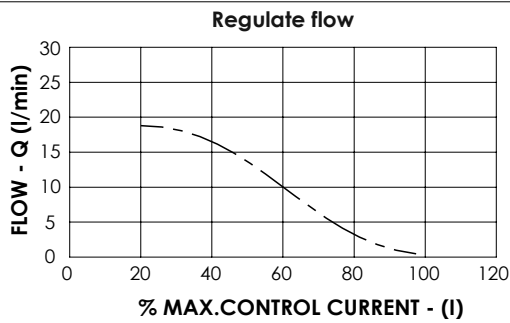

PRESSURE DROP DIAGRAM - 020

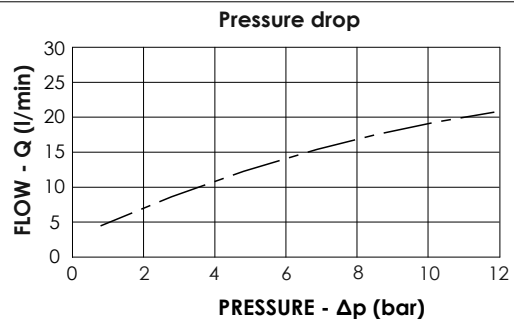

FLOW DIAGRAM - 010

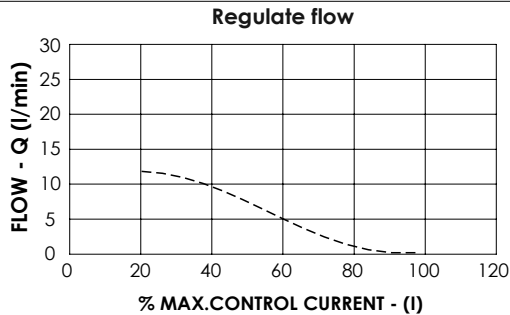

PRESSURE DROP DIAGRAM - 010

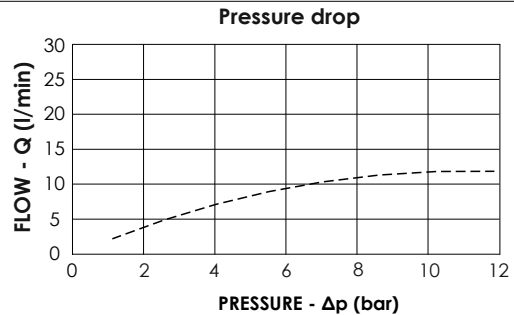

Spool type:

- 10 -----
- 20 -----
- 30 -----

The diagram shows the performance limit curve of a standard section. The fluid used is mineral oil with viscosity of 46 mm²/s @ 40 °C ; the tests are performed at a 40 °C temperature.

OVERALL DIMENSION - STANDARD SECTION

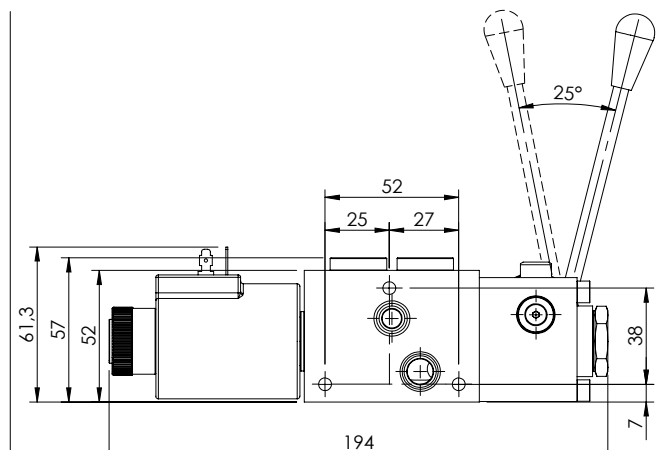
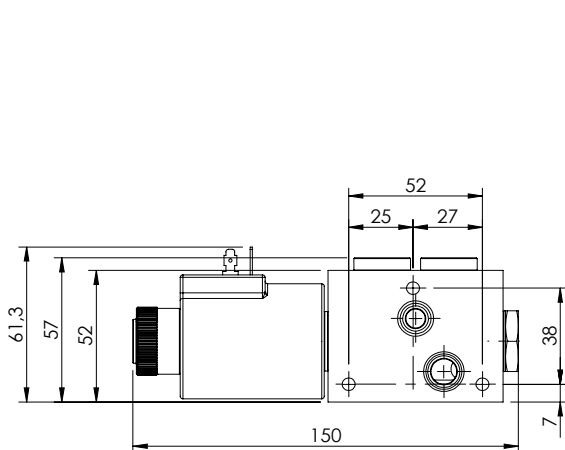

MANUAL LEVER

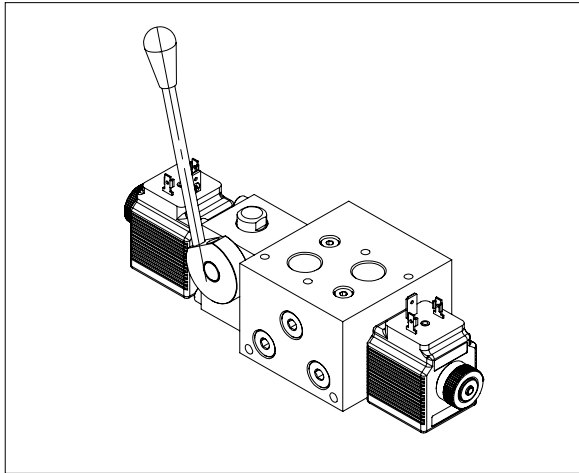

The lever option allow to operate manually the spool and can be ordered for all hydraulic schemes; in the standard version it is installed between monoblock and B port side coil. The lever is normally installed on the monoblock port side but can be installed also rotated of 180°; in each of these two positions the lever can be mounted vertical or horizontal simply removing the lever and reinstalling. The lever is not engaged during solenoid operation and doesn't move when a coil is energized.

TECHNICAL DATA

Tabella generale	
Max pressure	210/320 bar
Max pressure series version	210 bar
Rated flow	30/60 l/min
Duty cycle	100 % ED
Weight more than standard	2 Kg
Weight more than standard	2,5 kg

OVERALL DIMENSIONS/ LEVER FOR 30 L/MIN SECTION

The lever option is designed to activate the spool manually, when the lever is pulled the flow is delivered from the port close to the lever, when it is pushed the flow is delivered from the port opposite to the lever. The standard operation deliver full flow, in case of override operation it is possible to reduce the maximum stroke and consequently the speed, for this option contact AFT sales network. The lever can be easily positioned vertical or horizontal by unscrewing it from the rotating shaft.

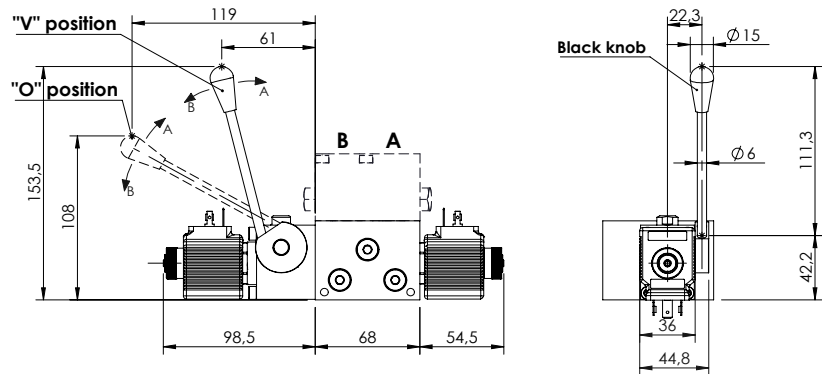

OVERALL DIMENSIONS/ LEVER FOR 60 L/MIN SECTION

The lever option is designed to activate the spool manually, when the lever is pulled the flow is delivered from the port close to the lever, when it is pushed the flow is delivered from the port opposite to the lever. The standard operation deliver full flow, in case of override operation it is possible to reduce the maximum stroke and consequently the speed, for this option contact AFT sales network. The lever can be easily positioned vertical or horizontal by unscrewing it from the rotating shaft.

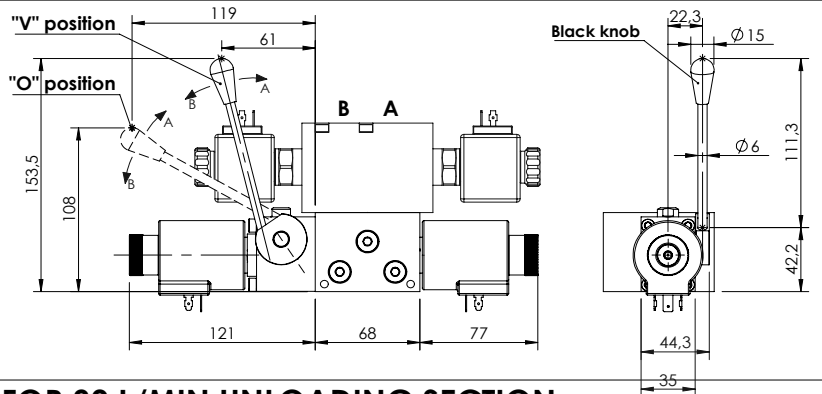

OVERALL DIMENSION/ LEVER FOR 30 L/MIN UNLOADING SECTION

The lever option is designed to activate the spool manually, when the lever is pulled the flow is delivered from the port close to the lever, when it is pushed the flow is delivered from the port opposite to the lever. The standard operation deliver full flow, in case of override operation it is possible to reduce the maximum stroke and consequently the speed, for this option contact AFT sales network. The lever can be easily positioned vertical or horizontal by unscrewing it from the rotating shaft.

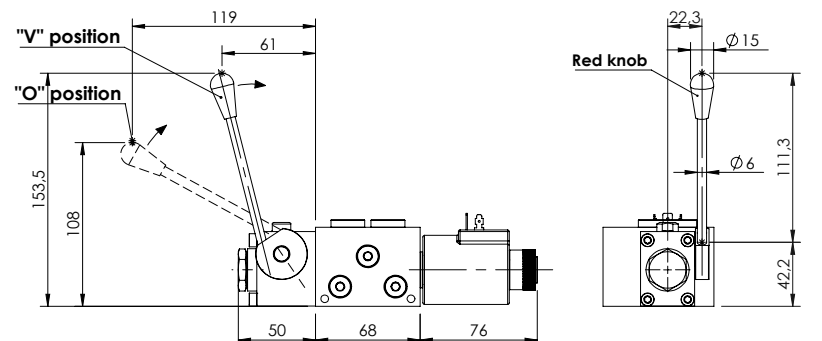

MOUNTING ELEMENTS

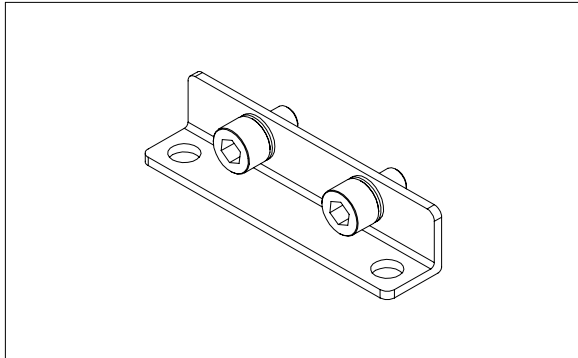

These parts are used to mount the directional valve on the application or to install modular valves and inlet section on the monoblock.

TECHNICAL DATA

Screw type	ISO 4762
Thread type	coarse thread
Standard screw	resistance class 8.8
High resistance screw	resistance class 12.9
Standard screw treatment	zinc-plated (white)
High res. screw treatment	Anodized (black)

MOUNTING BRACKETS

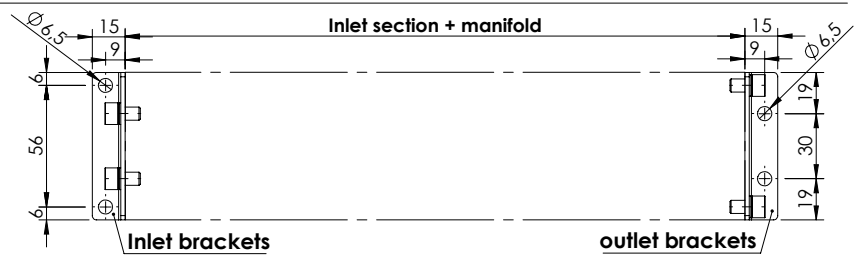
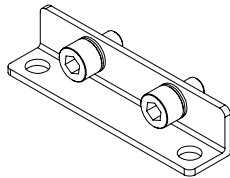

Mounting brackets	Screw length (mm)	Reference	Tightening Torque
PV000371	M6x10	AV000015 + PR000129	6 - 7 N/m

MOUNTING INLET SECTION

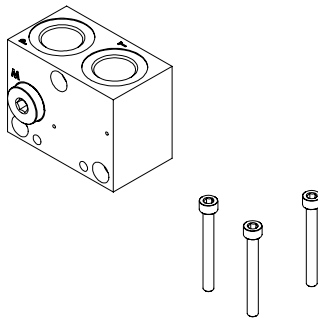

Inlet section	Screw length (mm)	Reference	Tightening Torque
SF000004	M6X40	AV000051	6 - 7 N/m
SF000016	M6X50	PE000100	6 - 7 N/m
SF000003	M6X60	AV000074	6 - 7 N/m
SF000002	M6X60	AV000074	6 - 7 N/m
SF000001	M6X75	PE000418	6 - 7 N/m

FIXING STACKING MODULES

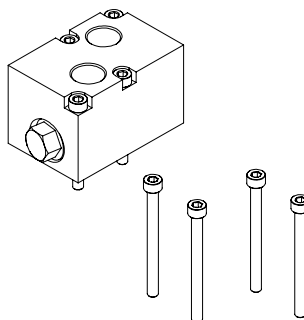

Flangiabile valve	Screw length (mm)	Reference	Tightening Torque
MP	M5x16	AV000035	3 - 4 N/m
MA, MC and MB	M5x45	PE000148	3 - 4 N/m
KE and MF	M5x60	AV000016	3 - 4 N/m



1800-OILSOL
1800-645765

<https://oilsolutions.com.au/>

sales@oilsolutions.com.au

EBL series

**MONOBLOCK
LOAD SENSING VALVE
ON-OFF OR
PROPORTIONAL**

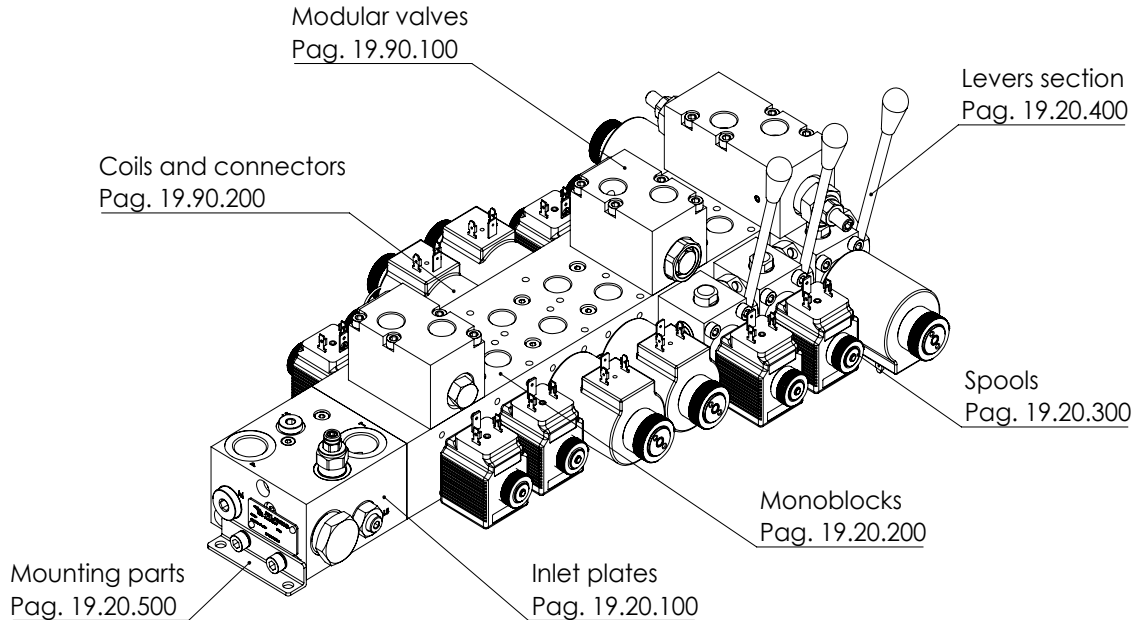

FEATURES

- Compact dimensions
- Low weight
- Custom spools
- Custom inlet blocks
- LS line on each spool section
- Sandwich valves for extra functions
- Cast iron monoblock and aluminum inlet block for standard applications
- High resistance cast iron monoblock and steel inlet block for high pressure systems
- Optional levers for manual operation
- No leak risk between sections
- Spools not under rod tension
- Zinc plated/anodized components for corrosion resistance

SPECIFICATION \ DESCRIPTION

MAXIMUM OPERATING PRESSURE	Steel inlet block: 320 bar (4600 PSI) Aluminium inlet block: 210 bar (3045 PSI)
MAXIMUM TANK PRESSURE	20 bar (290 PSI)
RATED FLOW	030 series: 30 l/min (7.9 GPM) 060 series: 60 l/min (15.8 GPM)
COIL POWER	030 series: 26 W 060 series: 33 W
VOLTAGE	12 Vdc, 24 V DC, others on request
COIL CONNECTOR	DIN43650, AMP Junior, Deutsch DT04-2P
PORTS	Inlet: G1/2", 1/2 JIS, 7/8-14 UNF-2B (SAE#10) Outlet: G3/8", 3/8 JIS, 3/4-16 UNF-2B (SAE#8)
OPERATING TEMPERATURE	NBR (ISO 1629) seals: -30, +80 °C FKM (ISO 1629) seals: -20, +110 °C
FILTRATION	ISO 4406:1999: class 19/17/14 NAS 1638: class 8
MOUNTING POSITION	No restrictions
MATERIAL	Spool body: cast iron Spool: Hardened and grounded steel Inlet block: Aluminium or steel
SURFACE TREATMENT	Steel: zinc plating Aluminium: anodization

EBL series is a new directional load sensing valve that has innovative features in terms of performance, dimension, manufacturing reliability and customization. The valve consists in an inlet block flanged to a monoblock with spools. This construction gives the advantages of high flexibility in inlet block schemes, combined with the reliability and simplicity of monoblock spool valve construction, eliminating the risk of spools blocking due to overtightening of tie rods or the risk of leakage between sections. The spool monoblock is a 2 or 3 position, 4 ways, direct acting solenoid operated type. All sections have threaded ports at the top and removable plugs for tank connections to allow the installation of flanged blocks with additional functions like crossover reliefs, reliefs to tank, relief and anticavitations, counterbalance valves, P.O. checks, flow restrictors and flow regulators. All sections are equipped with standard push button override and they can be equipped with lever for manual use.

HOW ORDER IT

To order the separate parts please refer to each catalogue page.

To order an assembled block, contact AFT sales network specifying the part numbers following page 19.90.900 path.

For special versions please contact AFT sales network.

EBL series - INLET SECTION

SFLL-060-ZDNN-16

P, T PORTS
M PORT

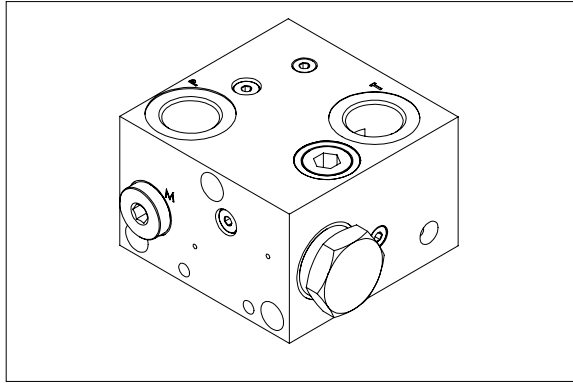

HYDRAULIC SCHEME

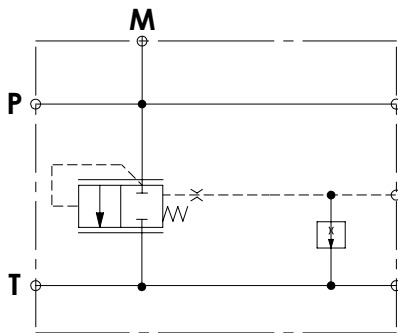

This inlet section is equipped with two thread ports (P,T) available in two different types G 1/2" or 3/4"-16 UNF plus a third threaded port M for pressure measuring available in G 1/4" or 7/16"-20. The manifold material is aluminium for applications up to 210 bar or zinc plated steel for applications up to 320 bar.

TECHNICAL DATA

Max pressure	210/320 bar
Rated flow	60 l/min
Hydraulic fluid	Mineral oil DIN 51524
Fluid viscosity	10-500 mm ² /s
Fluid temperature	-25°C/75°C
Environment temperature	-25°C/60°C
Weight	0,9 Kg

PRESSURE DROP LOGIC ELEMENT

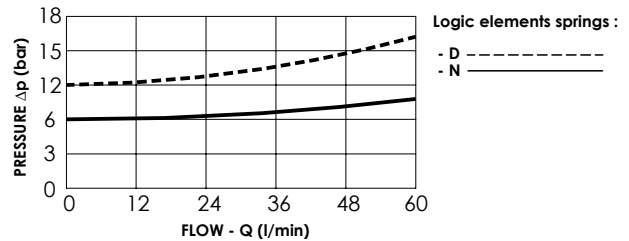

ORDERING DETAILS: SEPARATE ELEMENTS

SFLL-060- * * NN-16- * -N**

* MATERIAL TYPE	
A	Steel zinc-plated (320 bar)
Z	Aluminium anodized (210 bar)
* LOGIC ELEMENT SPRING	
D	Spring setting 12 bar (CD000103)
N	Spring setting 6 bar (CD000073)
*** PORTS	
	P line T line M
G12	G 1/2" G 1/2" G 1/4"
U34	3/4"-16 UNF 3/4"-16 UNF 7/16"-20 UNF
QUICK CODE	
DESCRIPTION	CODE
SFLL-060-ZDNN-16-G12-N	SF000045

OVERALL DIMENSIONS

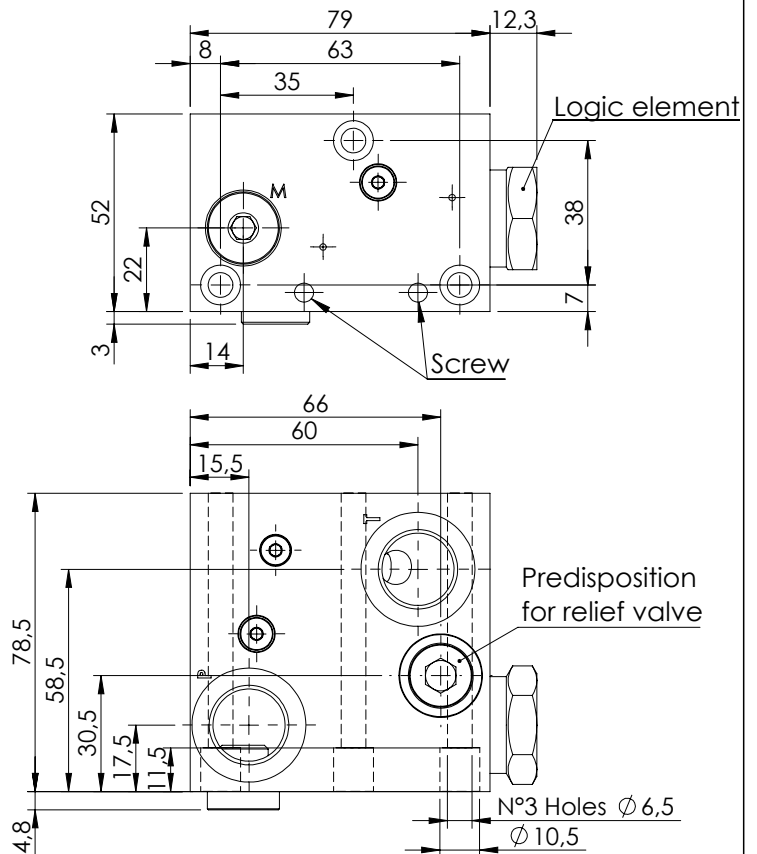

EBL series - INLET SECTION



SFLL-060-ZDNN-17

**RELIEF VALVE
M PORT**

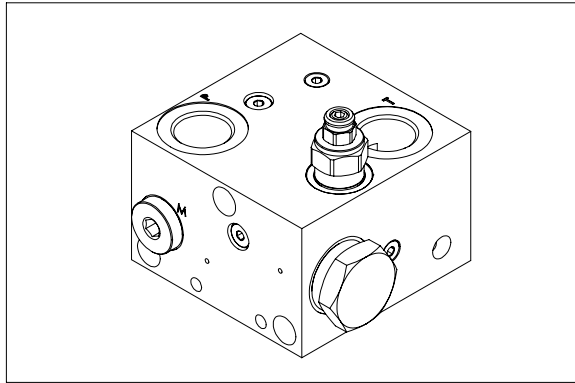

HYDRAULIC SCHEME

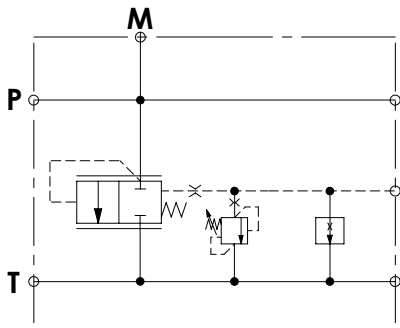

This inlet section is equipped with relief valve with adjustable setting operating on Ls signal, the adjustment is made by socket screw. This inlet section is equipped with two thread ports (P,T) available in two different types G 1/2" or 3/4"-16 UNF plus a third threaded port M for pressure measuring available in G 1/4" or 7/16"-20. The manifold material is aluminium for applications up to 210 bar or zinc plated steel for applications up to 320 bar.

TECHNICAL DATA

Max pressure	210/320 bar
Rated flow	60 l/min
Hydraulic fluid	Mineral oil DIN 51524
Fluid viscosity	10-500 mm ² /s
Fluid temperature	-25°C/75°C
Environment temperature	-25°C/60°C
Weight	0,9 Kg

PRESSURE DROP LOGIC ELEMENT

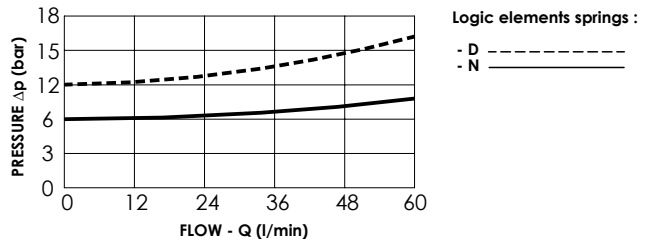

ORDERING DETAILS: SEPARATE ELEMENTS

SFLL-060-*N-17-***-N**

*	MATERIAL TYPE
A	Steel zinc-plated (320 bar)
Z	Aluminium anodized (210 bar)

*	LOGIC ELEMENT SPRING
D	Spring setting 12 bar (CD000103)
N	Spring setting 6 bar (CD000073)

*	SETTING RANGE
N	Max setting 210 bar (CP000029)
A	Max setting 110 bar (CP000030)
B	Max setting 350 bar (CP000002)

***	PORTS		
	P line	T line	M
G12	G 1/2"	G 1/2"	G 1/4"
U34	3/4"-16 UNF	3/4"-16 UNF	7/16"-20 UNF

QUICK CODE	
DESCRIPTION	CODE
SFLL-060-ZDNN-17-G12-N	SF000010
SFLL-060-ZNNN-17-G12-N	SF000032

OVERALL DIMENSIONS

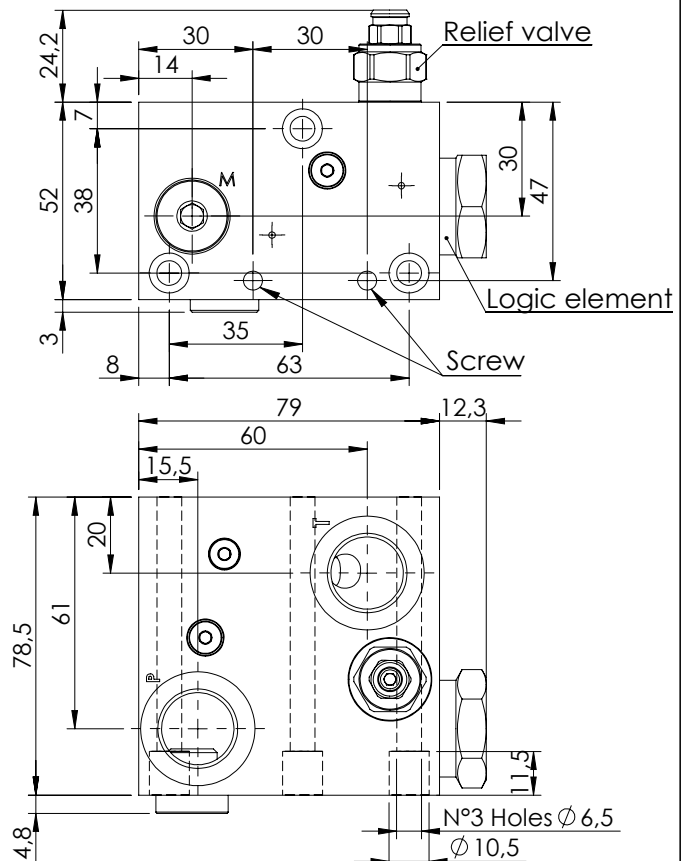

EBL series - INLET SECTION

SFLL-060-ZDNN-19

**RELIEF VALVE
UNLOADING VALVE**

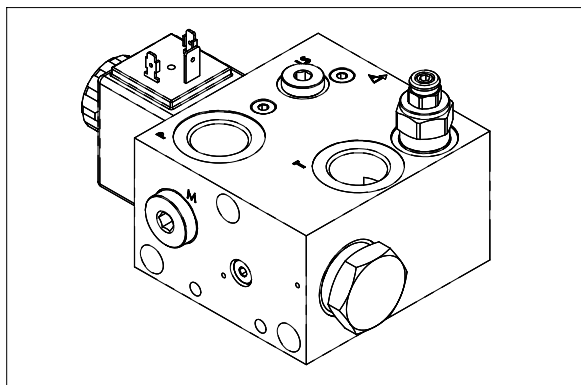

HYDRAULIC SCHEME

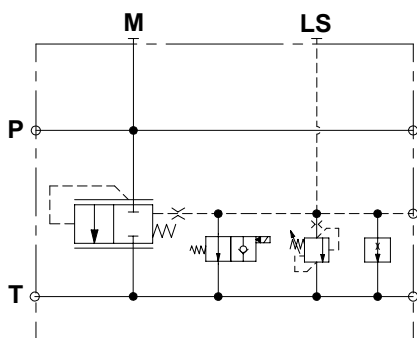

This inlet section is equipped with relief valve with adjustable setting operating on Ls signal, the adjustment is made by socket screw. It is present an unloading solenoid valve normally open with emergency operating on Ls signal. There are two thread ports (P, T) available in two different types G 1/2" or 3/4"-16 UNF plus M port available in G 1/4". Max inlet flow 60 l/min. The manifold material is aluminium for applications up to 210 bar or zinc plated steel for applications up to 320 bar.

TECHNICAL DATA

Max pressure	210/320 bar
Rated flow	60 l/min
Hydraulic fluid	Mineral oil DIN 51524
Fluid viscosity	10-500 mm ² /s
Fluid temperature	-25°C/75°C
Environment temperature	-25°C/60°C
Weight	1,05 Kg

PRESSURE DROP LOGIC ELEMENT

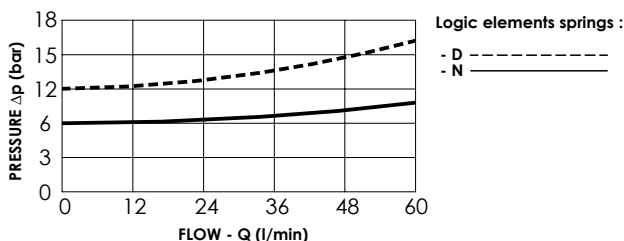

ORDERING DETAILS: SEPARATE ELEMENTS

SFLL-060-*N-19-***-***N**

*	MATERIAL TYPE
A	Steel zinc-plated (320 bar)
Z	Aluminium anodized (210 bar)

*	LOGIC ELEMENT SPRING
D	Spring setting 12 bar (CD000103)
N	Spring setting 6 bar (CD000073)

*	SETTING RANGE
N	Max setting 210 bar (CP000029)
A	Max setting 110 bar (CP000030)
B	Max setting 350 bar (CP000032)

***	PORTS
	P line T line M
G12	G 1/2" G 1/2" G 1/4"
U34	3/4"-16 UNF 3/4"-16 UNF 7/16"-20 UNF

*	VOLTAGE
	no coils
A	12 V DC
B	24 V DC

**	COILS TYPE
	no coils
HR	Hirshmann (ISO 4400 DIN 43650)
DT	Deutsch (DT04-2P)
AJ	Amp junior (AJ type)

QUICK CODE	
DESCRIPTION	CODE
SFLL-060-ZDNN-19-G12-N	SF000019
Unloading Valve	CE000873

OVERALL DIMENSIONS

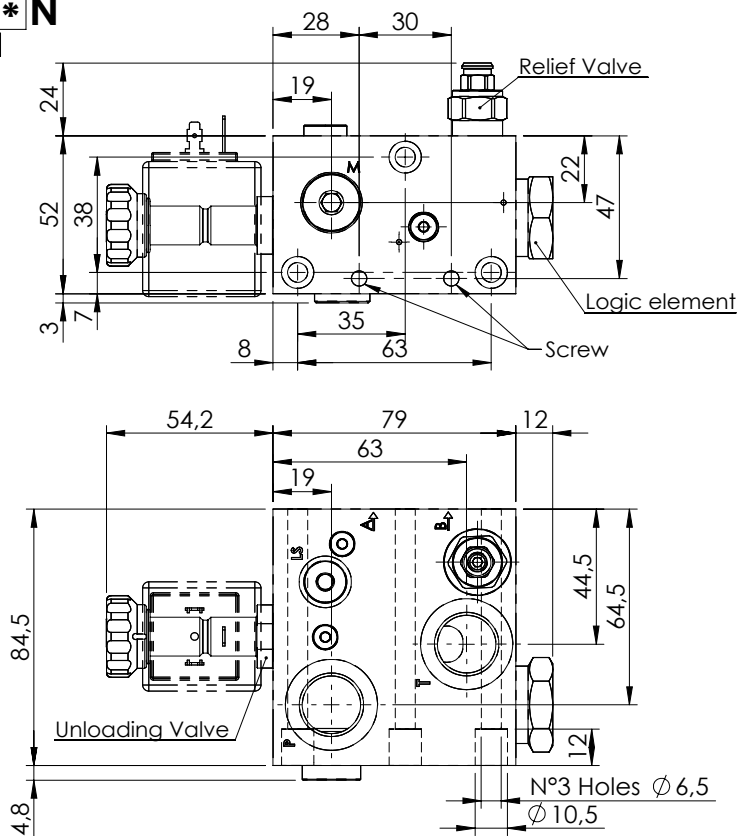

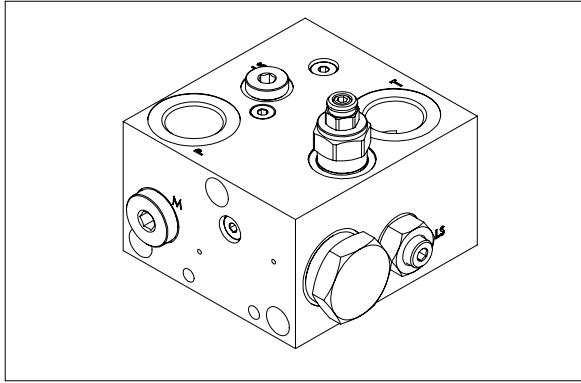

HYDRAULIC SCHEME

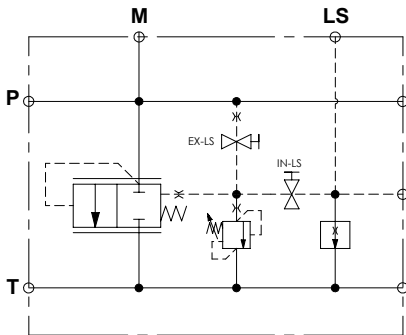

This inlet section is equipped with relief valve with adjustable setting operating on Ls signal, the adjustment is made by socket screw. It is present an unloading compensator normally closed operating with Ls signal. There are two thread ports (P, T) available in two different types G 1/2" or 3/4"-16 UNF plus M port available in G 1/4". Max inlet flow 60 l/min. The manifold material is aluminium for applications up to 210 bar or zinc plated steel for applications up to 320 bar.

TECHNICAL DATA

Max pressure	210/320 bar
Rated flow	60 l/min
Hydraulic fluid	Mineral oil DIN 51524
Fluid viscosity	10-500 mm ² /s
Fluid temperature	-25°C/75°C
Environment temperature	-25°C/60°C
Weight	1 Kg

PRESSURE DROP LOGIC ELEMENT

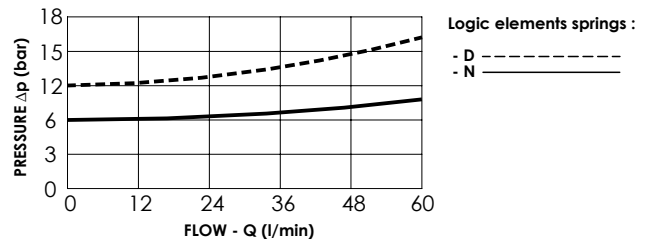

ORDERING DETAILS: SEPARATE ELEMENTS

SFLL-060-*N-18-***-N**

*	MATERIAL TYPE		
A	Steel zinc-plated (320 bar)		
Z	Aluminium anodized (210 bar)		
*	LOGIC ELEMENT SPRING		
D	Spring setting 12 bar (CD000103)		
N	Spring setting 6 bar (CD000073)		
*	SETTING RANGE		
N	Max setting 210 bar (CP000029)		
A	Max setting 110 bar (CP000030)		
B	Max setting 350 bar (CP000002)		
***	PORTS		
	P line	T line	M
G12	G 1/2"	G 1/2"	G 1/4"
U34	3/4"-16 UNF	3/4"-16 UNF	7/16"-20 UNF
	QUICK CODE		
	DESCRIPTION	CODE	
	SFLL-060-ZDNN-18-G12-N	SF000011	
	SFLL-060-ZNNN-18-G12-N	SF000031	

OVERALL DIMENSIONS

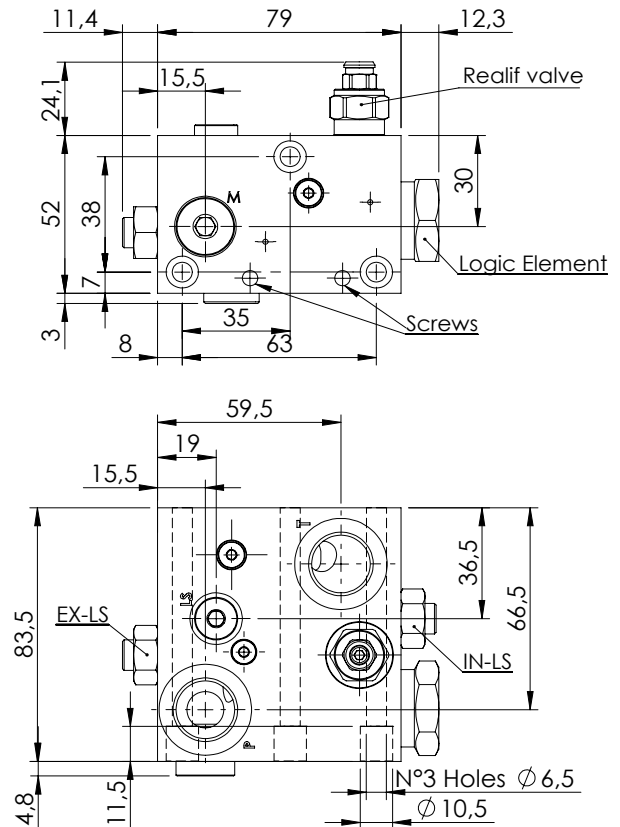

LDLP-060-NNNN

CAST-IRON MANIFOLD

In LDNS/P-030-C plug are included in the manifold

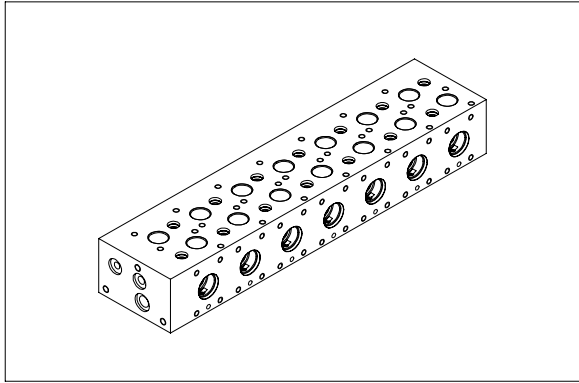

The monoblock valve can be ordered with a number of spool's section from 1 to 7, each section is equipped with side mounting holes for lever option and with threaded holes at the top for flangeable modular valve. There are also two removable plugs connecting to a T line to allow to flange special blocks.

The standard version has G 3/8" ports and can be supplied with top blocks with 9/16"-18 UNF (SAE6) or M16x1,5.

The manifold it is made with cast-iron and protected from corrosion with zinc-plating surface treatment.

The inlet face has 3 threaded holes to flange an inlet block that can be customized for each application, giving high flexibility to the project.

TECHNICAL DATA

Max pressure	320 bar
Rated flow	60 l/min
Material	Cast-iron
Surface treatment	Zinc-plated black
Weight for single section	1,9 kg
Wight for additional sections	+ 1,1 Kg each

ORDERING DETAILS: SEPARATE ELEMENTS

LDL * -060- NNNN - ** - ***

* TYPE OF MANIFOLD	
S	Series connection
P	Parallel connection
** NUMBER OF SECTION	
01	manifold with one section
02	manifold with two sections
03	manifold with three sections
04	manifold with four sections
05	manifold with five sections
06	manifold with six sections
07	manifold with seven sections

***	PORTS		
	P line	T line	M
G38	G 3/8"	G 3/8"	G 1/4"
U09	9/16"-18 UNF	9/16"-18 UNF	7/16"-20 UNF

QUICK CODE	
DESCRIPTION	CODE
LDLP-060-NNNN-01-G38	LD000183
LDLP-060-NNNN-02-G38	LD000184
LDLP-060-NNNN-03-G38	LD000185
LDLP-060-NNNN-04-G38	LD000187
LDLP-060-NNNN-05-G38	LD000188
LDLP-060-NNNN-06-G38	LD000189
LDLP-060-NNNN-07-G38	LD000190

MANIFOLD CONFIGURATIONS

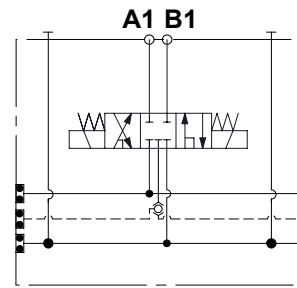

LDLP-060

MONOBLOCK PRESSURE DROP

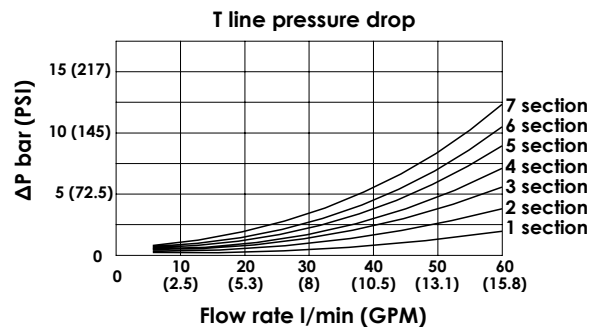
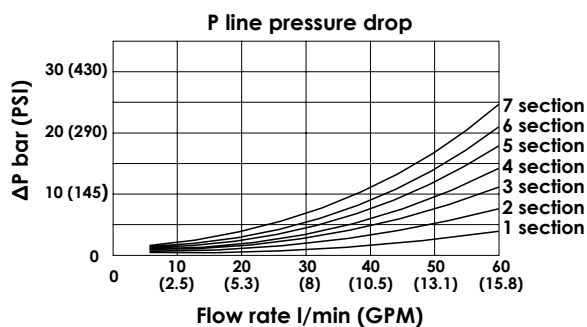

SHNE-030-LSON

30 L/MIN
SOLENOID VALVE

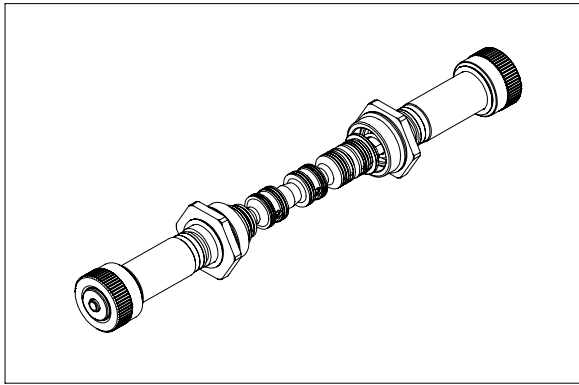

This spool group is rated for 30 lpm and for a maximum pressure of 320 bar; the spool is actuated by on off tubes and can be ordered with different hydraulic schemes. Each spools is interchangeable to give maximum flexibility and can be fit in all monoblock sections, changing spools require adequate training. The group is made by two tubes, one spool, two springs and mounting components.

TECHNICAL DATA

Max pressure	320 bar
Rated flow	30 l/min
Max excitation frequency	3 Hz
Duty cycle	100 % ED
Hydraulic fluid	Mineral oil DIN 51524
Fluid viscosity	10/500 mm ² /s
Fluid temperature	-25°C/75°C
Enviroment temperature	-25°C/60°C
Weight with one solenoid	0,12 Kg
Weight with two solenoid	0,15kg

ORDERING DETAILS: SEPARATE ELEMENTS

SH* *- 030 - LS** - ** -396 - * ** N

*	VERRIDE TYPE
N	Standard
P	Push
V	Screw

*	SECTION TYPE
E	Solenoid operated
L	Solenoid operated plus lever operated
M	Lever operated

**	ACTUATION TYPE
ON	On/Off
SS	Soft shift

**	SPOOL TYPE
...	See table n°1

*	COILS VOLTAGE
	no coils
A	12 V DC
B	24 V DC

**	COILS TYPE
	no coils
HR	Hirschmann (ISO 4400 DIN 43650)
DT	Deutshc (DT04-2P)
AJ	Amp Junior (AJ type)

QUICK CODE	
DESCRIPTION	CODE
SHNE-030-LSON-74-396	
SHNE-030-LSON-75-396	

HYDRAULIC SYMBOLS

Table n°1

SPOOL CODE	HYDRAULIC SCHEME	TRANSITORY POSITION	
74			
75			
SPOOL CODE	HYDRAULIC SCHEME	TRANSITORY POSITION	
a	b	a	b

VERRIDE TYPE

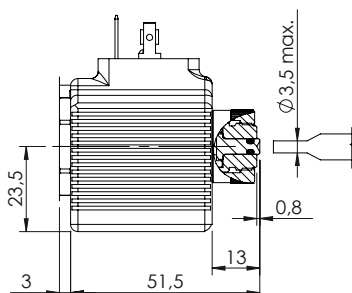

VERRIDE TYPE "N"

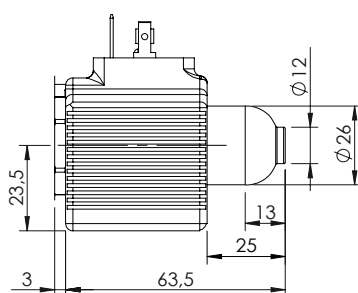

VERRIDE TYPE "P"

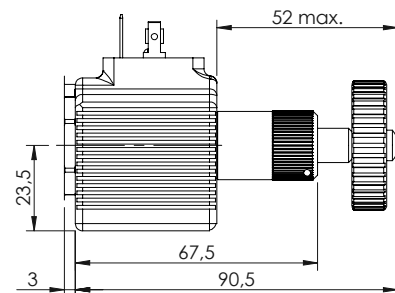

VERRIDE TYPE "V"

SHNE-030-LSON

30 L/MIN SOLENOID VALVE

PERFORMANCE LIMITS CURVES - STANDARD SECTION

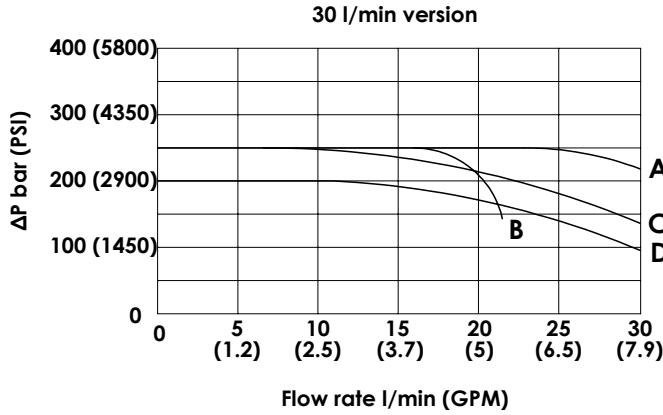

Spool type	Performance limits curve
74	A
75	A
	B
	A
	A
	A
	C
	D

The tests are carried out with hot solenoids, powered with 90 % of nominal voltage, with 50 °C fluid temperature. The fluid used is mineral oil having a viscosity of 46 mm² / s @ 40 °C. The values in the diagram refer to tests carried out with flow simultaneously in both directions (P > A, B > T). In cases of schemes 4/2 or 4/3 used with the flow in one direction only the performance can change.

PRESSURE DROP CURVES - STANDARD SECTION

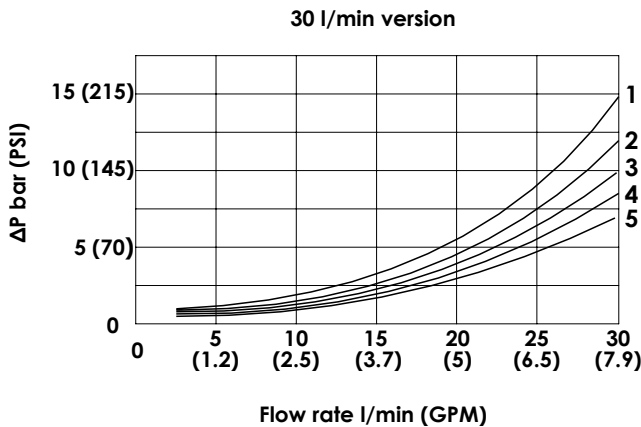

Spool type	Pressure drop curve				
	P>A	P>B	A>T	B>T	P>T
74	3	3	4	4	/
75	3	3	5	5	/
	2	2	1	1	2
	/	3	4	/	/
	/	3	5	/	/
	2	/	/	1	/
	/	3	4	/	/
	/	2	3	/	/

The diagram shows the performance limit curve of standard section. The fluid used is mineral oil viscosity 46 mm²/s at 40 °C ; the tests are performed at a 40 °C temperature

OVERALL DIMENSION - STANDARD SECTION

In case of top modular valve MA or MC type installation the coil connection can be faced to the top or to the bottom of the block. (See modular valve section)

In case of top modular valve MB, KE and KF type installation the coil connection can be faced only to the bottom of the block. (See modular valve section)

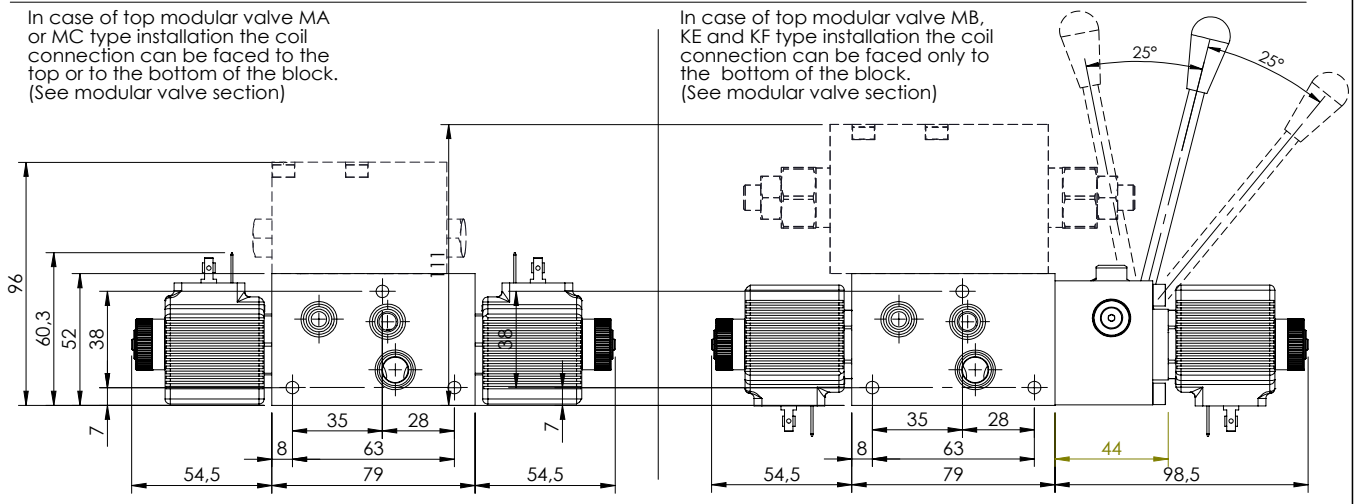

SHNE-060-LSON

60 L/MIN
SOLENOID VALVE

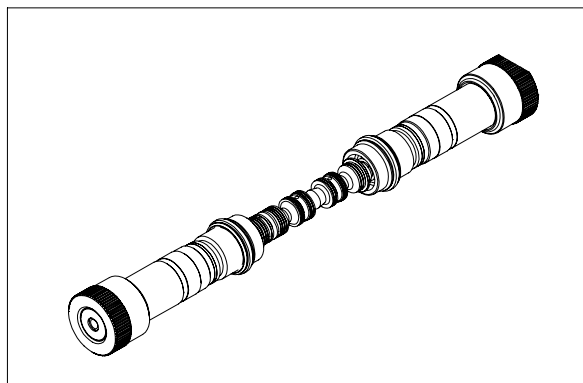

This spool group is rated for 60 lpm and for a maximum pressure of 320 bar; the spool is actuated by on off tubes and can be ordered with different hydraulic schemes. Each spools is interchangeable to give maximum flexibility and can be fit in all monoblock sections, changing spools require adequate training. The group is made by two tubes, one spool, two springs and mounting components.

TECHNICAL DATA

Max pressure	320 bar
Rated flow	60 l/min
Max excitation frequency	3 Hz
Duty cycle	100 % ED
Hydraulic fluid	Mineral oil DIN 51524
Fluid viscosity	10/500 mm ² /s
Fluid temperature	-25°C/75°C
Enviroment temperature	-25°C/60°C
Weight with one solenoid	0,2 Kg
Weight with two solenoid	0,4 kg

ORDERING DETAILS: SEPARATE ELEMENTS

SH** - 060 - LS** - ** - 396 - ** * N

*	VERRIDE TYPE
N	Standard
P	Push
V	Screw

*	SECTION TYPE
E	Solenoid operated
L	Solenoid operated plus lever operated
M	Lever operated

**	ACTUATION TYPE
ON	On/Off
SS	Soft shift

**	SPOOL TYPE
...	See table n°1

**	COILS VOLTAGE
	no coils
A	12 V DC
B	24 V DC

**	COILS TYPE
	no coils
HR	Hirschmann (ISO 4400 DIN 43650)
DT	Deutshc (DT04-2P)
AJ	Amp Junior (AJ type)

QUICK CODE	
DESCRIPTION	CODE
SHNE-060-LSON-74-396	
SHNE-060-LSON-75-396	

HYDRAULIC SYMBOLS

Table n°1

SPOOL CODE	HYDRAULIC SCHEME	TRANSITORY POSITION
74		
75		
SPOOL CODE	HYDRAULIC SCHEME	TRANSITORY POSITION
a	b	a

VERRIDE TYPE

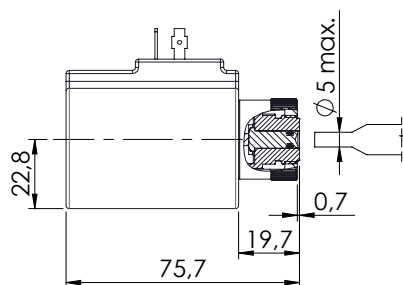

VERRIDE TYPE "N"

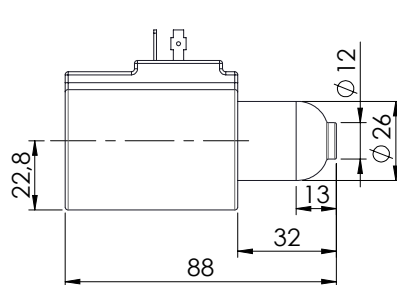

VERRIDE TYPE "P"

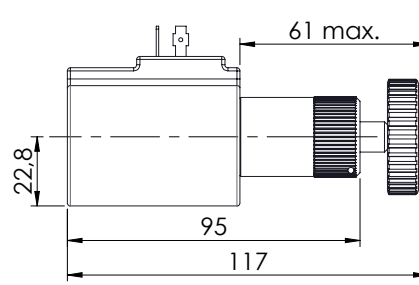

VERRIDE TYPE "V"

PERFORMANCE LIMIT CURVES - STANDARD SECTION

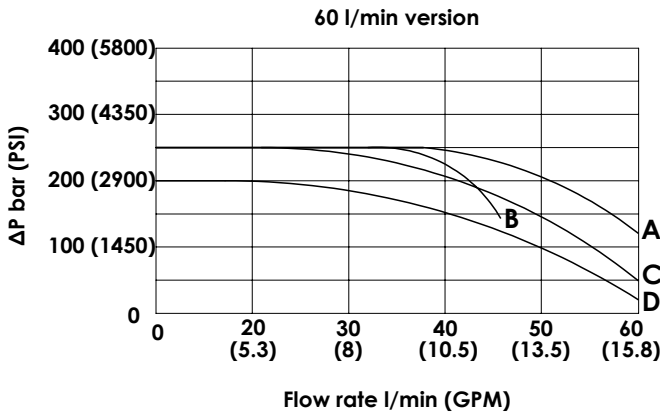

Spool type	Performance limits curve
74	A
75	A
	B
	A
	A
	A
	C
	D

The tests are carried out with hot solenoids , powered with 90 % of nominal voltage , with 50 ° C fluid temperature. The fluid used is mineral oil having a viscosity of 46 mm² / s @ 40 ° C .

The values in the diagram refer to tests carried out with flow simultaneously in both directions (P > A , B > T).

In cases of schemes 4/2 or 4/3 used with the flow in one direction only the performance can change.

PRESSURE DROP CURVES - STANDARD SECTION

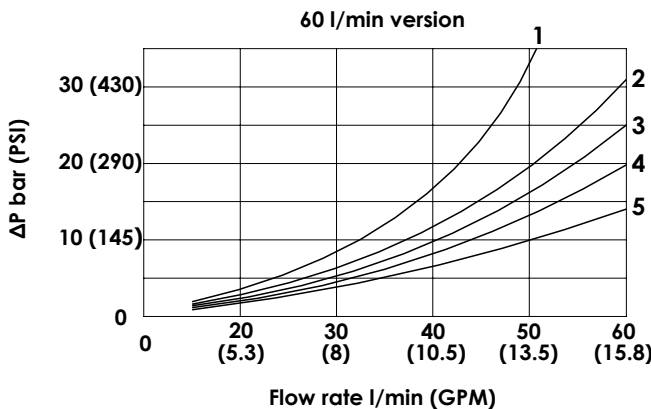

Spool type	Pressure drop curve				
	P>A	P>B	A>T	B>T	P>T
74	3	3	4	4	/
75	3	3	5	5	/
	2	2	1	1	2
	/	3	4	/	/
	/	3	5	/	/
	2	/	/	1	/
	/	3	4	/	/
	/	2	3	/	/

The diagram shows the performance limit curve of standard section. The fluid used is mineral oil viscosity 46 mm²/s at 40 ° C ; the tests are performed at a 40 ° C temperature

OVERALL DIMENSION - STANDARD SECTION

In case of top modular valve MA or MC type installation the coil connection can be faced to the top or to the bottom of the block. (See modular valve section)

In case of top modular valve MB, KE and KF type installation the coil connection can be faced only to the bottom of the block. (See modular valve section)

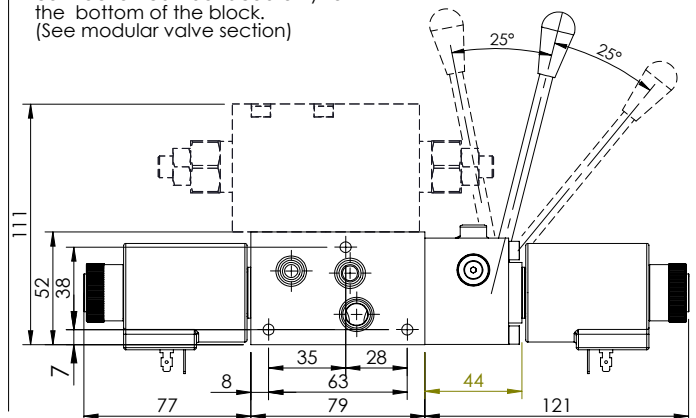
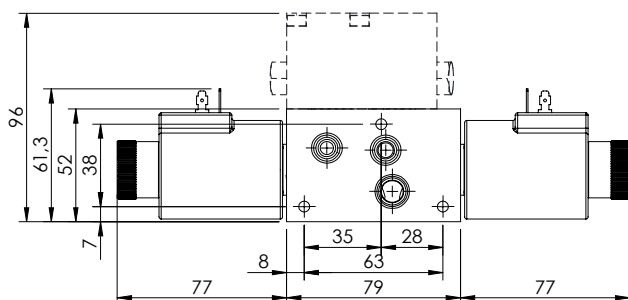

SHNE-050-LSPR

50 L/MIN
PROPORTIONAL
SOLENOID VALVE

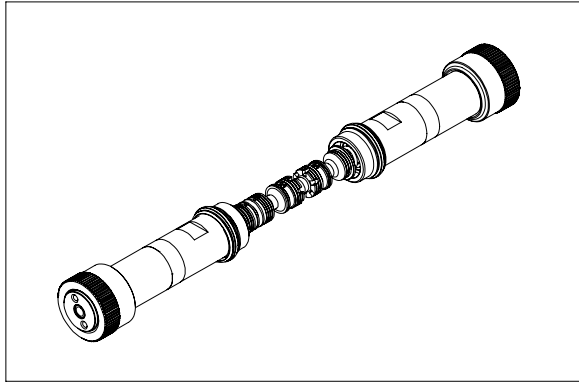

This spool group is rated for 50 lpm and for a maximum pressure of 320 bar; the spool is actuated by proportional tubes and can be ordered with different hydraulic schemes. Each spools is interchangeable to give maximum flexibility and can be fit in all monoblock sections, changing spools require adequate training. The group is made by two tubes, one spool, two springs and mounting components.

TECHNICAL DATA

Max pressure	320 bar
Rated flow	50 l/min
Max excitation frequency	3 Hz
Duty cycle	100 % ED
Max current	1.76A (12 V dc) 0.88A (24 V dc)
Hydraulic fluid	Mineral oil DIN 51524
Fluid viscosity	10/500 mm ² /s
Fluid temperature	-25°C/75°C
Environment temperature	-25°C/60°C
Weight with one solenoid	0,5 Kg
Weight with two solenoid	0,7 kg

ORDERING DETAILS: SEPARATE ELEMENTS

SH** - 0** - LSPR - ** - 396 - ***N

*	VERRIDE TYPE
N	Standard
P	Push
V	Screw

*	SECTION TYPE
E	Solenoid operated
L	Solenoid operated plus lever operated
M	Lever operated

**	SPOOL FLOW
20	20 l/min at 12 bar - 10 l/min at 6 bar
35	35 l/min at 12 bar - 20 l/min at 6 bar
50	50 l/min at 12 bar - 30 l/min at 6 bar

**	ROPORTIONAL TYPE
...	See table n°1

*	COILS VOLTAGE
	no coils
A	12 V DC
B	24 V DC

**	COILS TYPE
	no coils
HR	Hirschmann (ISO 4400 DIN 43650)
DT	Deutshc (DT04-2P)
AJ	Amp Junior (AJ type)

QUICK CODE	
DESCRIPTION	CODE
SHNE-030-LSPR-77-396	
SHNE-030-LSPR-78-396	

TECHNICAL FEATURES

Proportionl type	Spool flow	Rated flow with 12 bar ΔP	Maximum flow	Max. operating pressure
All	20	15	20	320
All	35	30	35	320
All	50	45	50	320

Proportionl type	Spool flow	Rated flow with 6 bar ΔP	Maximum flow	Max. operating pressure
All	20	10	15	320
All	35	20	25	320
All	50	30	35	320

HYDRAULIC SYMBOLS

Table n°1

SPOOL CODE	HYDRAULIC SCHEME	TRANSITORY POSITION
77		
78		

VERRIDE TYPE

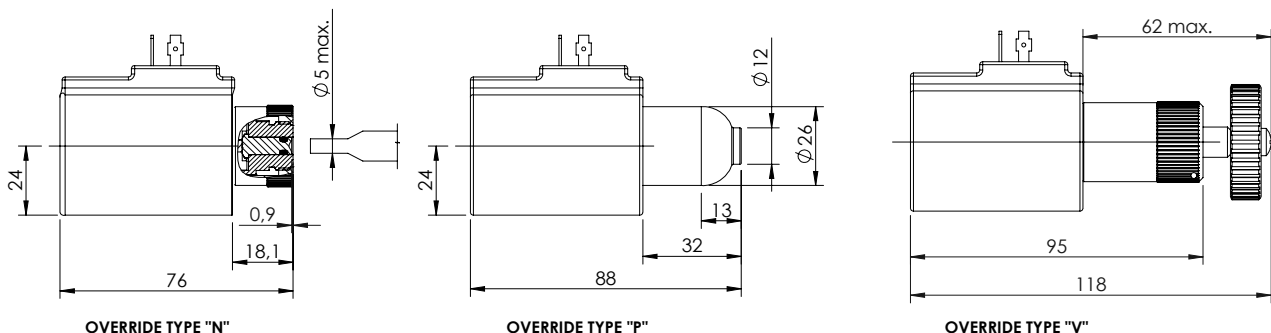

SHNE-050-LSPR

50 L/MIN
PROPORTIONAL
SOLENOID VALVE

FLOW DIAGRAM - 050

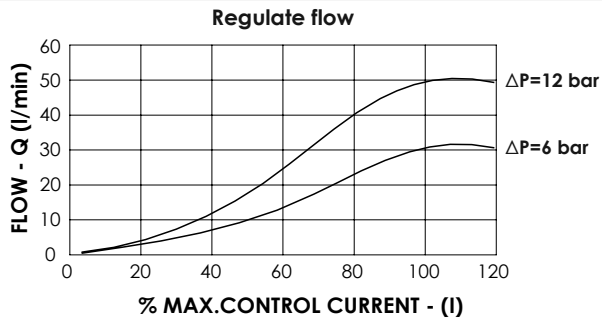

COMPESATION DIAGRAM - 050

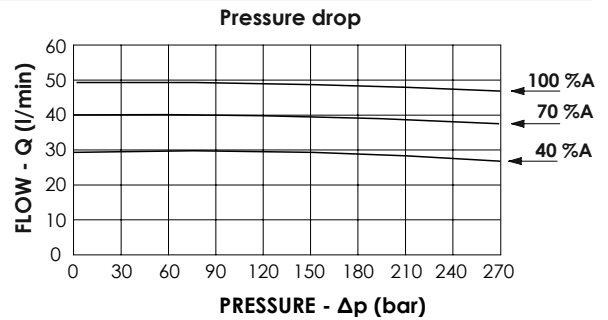

FLOW DIAGRAM - 035

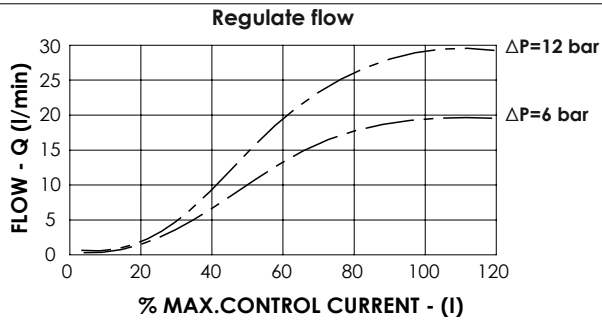

COMPENSATION DIAGRAM - 035

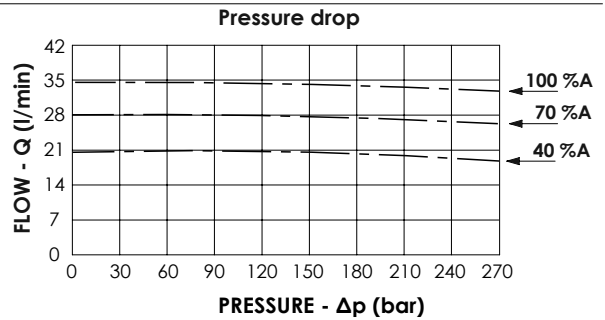

FLOW DIAGRAM - 020

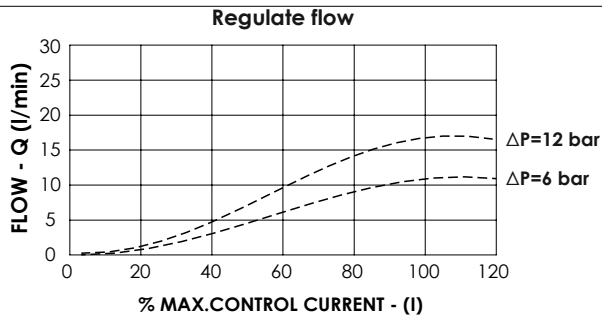

COMPENSATION DIAGRAM - 020

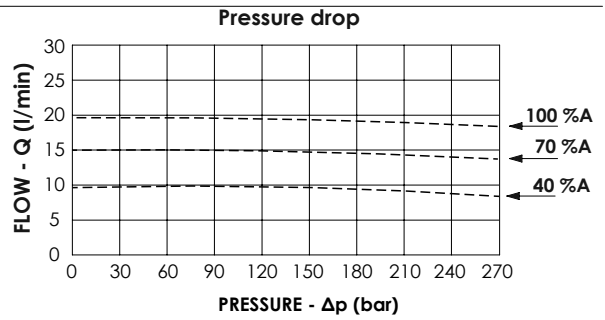

Spool type:

- 10 -----
- 20 -----
- 30 -----

In the diagram shows the performance limits curves of standard section. The fluid used is mineral oil viscosity 46 mm²/s at 40 °C ; the tests were performed at a 40 °C temperature

OVERALL DIMENSION - STANDARD SECTION

In case of top modular valve MA or MC type installation the coil connection can be faced to the top or to the bottom of the block. (See modular valve section)

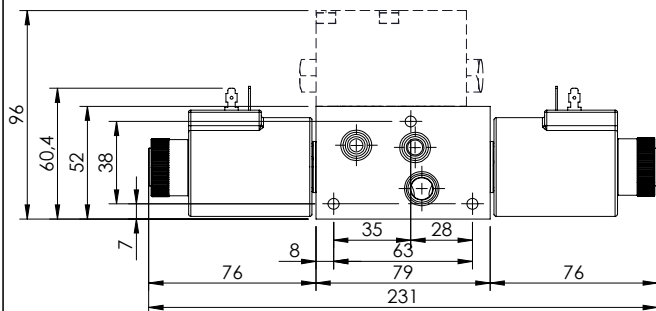

In case of top modular valve MB, KE and KF type installation the coil connection can be faced only to the bottom of the block. (See modular valve section)

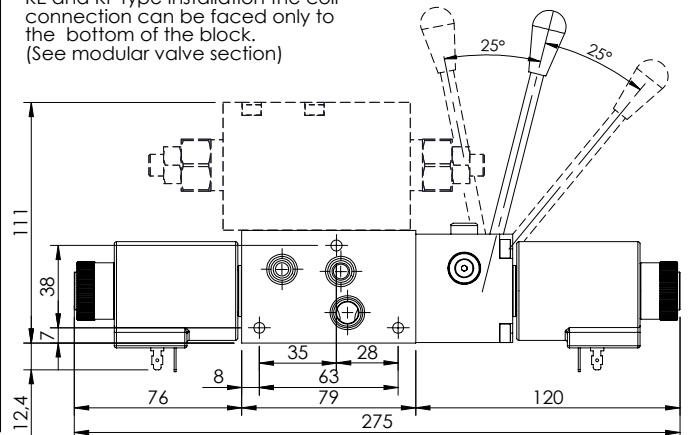

MANUAL LEVER

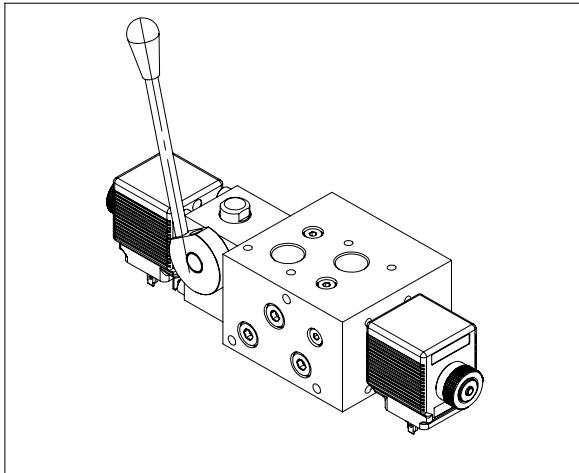

The lever option allow to operate manually the spool and can be ordered for all hydraulic schemes; in the standard version it is installed between monoblock and B port side coil. The lever is normally installed on the monoblock port side but can be installed also rotated of 180°; in each of these two positions the lever can be mounted vertical or horizontal simply removing the lever and reinstalling. The lever is not engaged during solenoid operation and doesn't move when a coil is energized.

TECHNICAL DATA

Max pressure	210/320 bar
Max pressure in line type	210 bar
Rated flow	30/60 l/min
Insertion	100 % ED
Weight more than standard	2 Kg
Weight more than standard	2,5 kg

OVERALL DIMENSIONS/ LEVER FOR 30 L/MIN SECTION

The lever option is designed to activate the spool manually, when the lever is pulled the flow is delivered from the port close to the lever, when it is pushed the flow is delivered from the port opposite to the lever. The standard operation deliver full flow, in case of override operation it is possible to reduce the maximum stroke and consequently the speed, for this option contact AFT sales network. The lever can be easily positioned vertical or horizontal by unscrewing it from the rotating shaft.

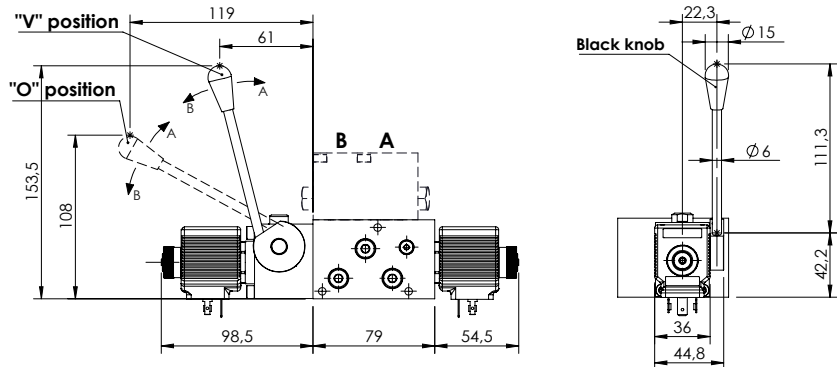

OVERALL DIMENSIONS/ LEVER FOR 60 L/MIN SECTION

The lever option is designed to activate the spool manually, when the lever is pulled the flow is delivered from the port close to the lever, when it is pushed the flow is delivered from the port opposite to the lever. The standard operation deliver full flow, in case of override operation it is possible to reduce the maximum stroke and consequently the speed, for this option contact AFT sales network. The lever can be easily positioned vertical or horizontal by unscrewing it from the rotating shaft.

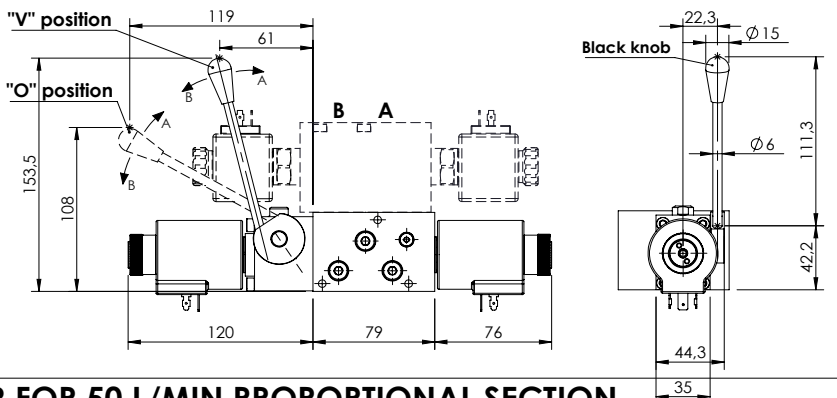

OVERALL DIMENSION/ LEVER FOR 50 L/MIN PROPORTIONAL SECTION

The lever option is designed to activate the spool manually, when the lever is pulled the flow is delivered from the port close to the lever, when it is pushed the flow is delivered from the port opposite to the lever. The standard operation deliver full flow, in case of override operation it is possible to reduce the maximum stroke and consequently the speed, for this option contact AFT sales network. The lever can be easily positioned vertical or horizontal by unscrewing it from the rotating shaft.

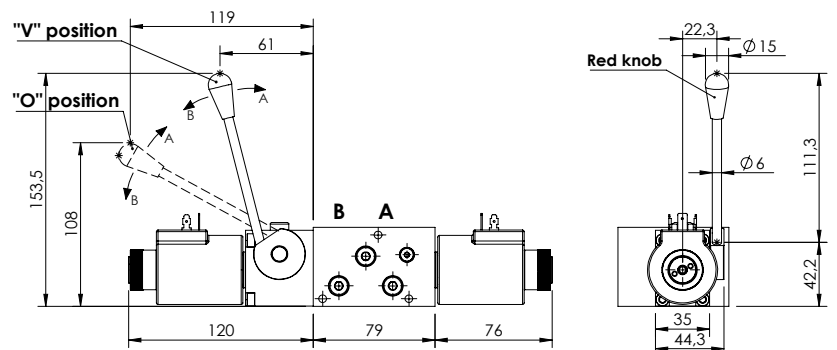

MOUNTING SCREW

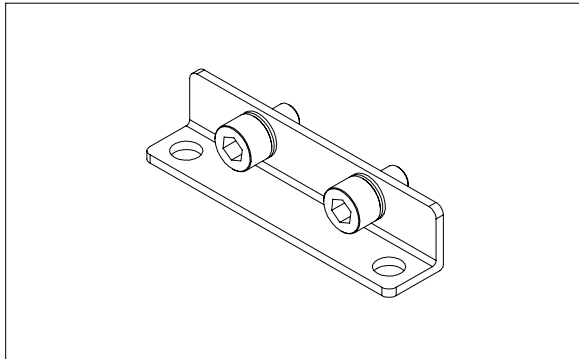

These parts are used to mount the directional valve on the application or to install modular valves and inlet section on the monoblock.

TECHNICAL DATA

Screw type	ISO 4762
Thread type	coarse thread
Standard screw	resistance class 8.8
High resistance screw	resistance class 12.9
Standard screw treatment	zinc-plated (white)
High res. screw treatment	Anodized (black)

MOUNTING BRACKETS

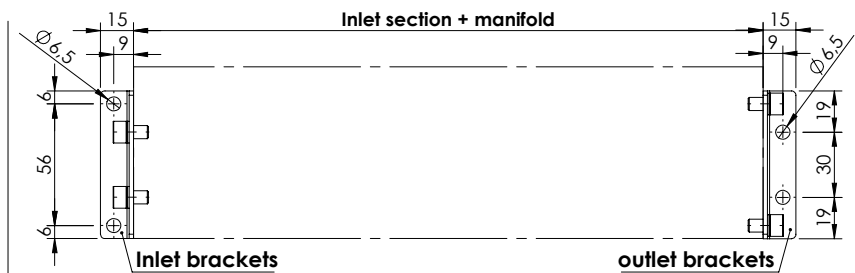
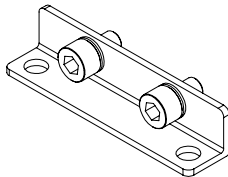

Mounting brackets	Screw length (mm)	Reference	Tightening Torque
PV000371	M6x10	AV000015 + PR000129	6 - 7 N/m

MOUNTING INLET SECTION

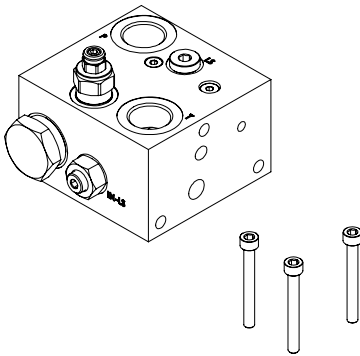

Inlet section	Screw length (mm)	Reference	Tightening Torque
SF000011	M6x80	AV000073	6 - 7 N/m
SF000019	M6x80	AV000073	6 - 7 N/m
SF000042	M6x75	PE000418	6 - 7 N/m
SF000045	M6x75	PE000418	6 - 7 N/m

FIXING STACKING MODULES

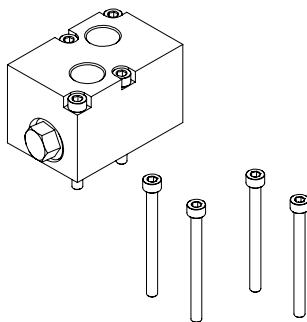

Flangiabe valve	Screw length (mm)	Reference	Tightening Torque
MP	M5x16	AV000035	3 - 4 N/m
MA, MC and MB	M5x45	PE000148	3 - 4 N/m
KE and MF	M5x60	AV000016	3 - 4 N/m



1800-OILSOL
1800-645765

<https://oilsolutions.com.au/>

sales@oilsolutions.com.au

EBP series

**MONOBLOCK
PRE-COMPENSATED
LOAD SENSING VALVE
ON-OFF OR PROPORTIONAL**

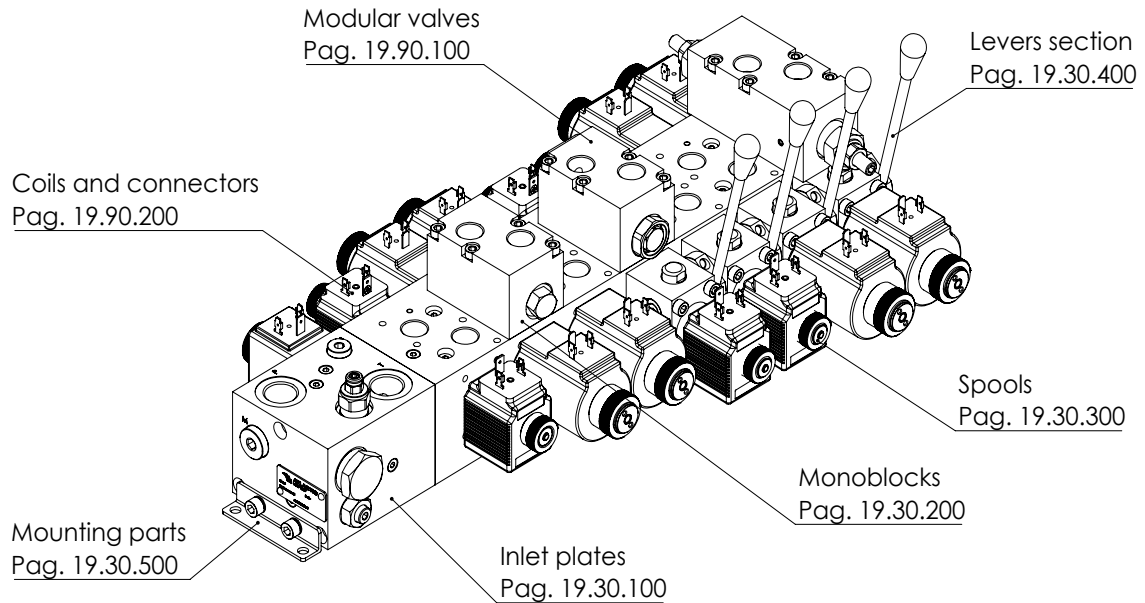

FEATURES

- Compact dimensions
- Low weight
- Custom spools
- Custom inlet blocks
- LS line on each spool section
- LS compensator on each spool section
- Sandwich valves for extra functions
- Cast iron monoblock and aluminum inlet block for standard applications
- High resistance cast iron monoblock and steel inlet block for high pressure systems
- Optional levers for manual operation
- No leak risk between sections
- Spools not under rod tension
- Zinc plated/anodized components for corrosion resistance

SPECIFICATION \ DESCRIPTION

MAXIMUM OPERATING PRESSURE	Steel inlet block: 320 bar (4600 PSI) Aluminium inlet block: 210 bar (3045 PSI)
MAXIMUM TANK PRESSURE	20 bar (290 PSI)
RATED FLOW	030 series: 30 l/min (7.9 GPM) 060 series: 60l/min (15.8 GPM)
COIL POWER	030 series: 26 W 060 series: 33 W
VOLTAGE	12 V dc, 24 VDC, others on request
COIL CONNECTOR	DIN43650, AMP Junior, Deutsch DT04
PORTS	Inlet: G1/2", 1/2 JIS, 7/8-14 UNF-2B (SAE#10) Outlet: G3/8", 3/8 JIS, 3/4-16 UNF-2B (SAE#8)
OPERATING TEMPERATURE	NBR (ISO 1629) seals: -30, + 80 °C FKM (ISO 1629) seals: -20, +110 °C
FILTRATION	ISO 4406 17/14 or better
MOUNTING POSITION	No restrictions
MATERIAL	Spool body: cast iron Spool: Hardened and grounded steel Inlet block: Aluminium or steel
SURFACE TREATMENT	Steel: zinc plating Aluminium: anodization

EBN series is a new directional load sensing pre-compesated valve that has innovative features in terms of performance, dimension, manufacturing reliability and customization. The valve consists in an inlet block flanged to a monoblock with spools. This construction gives the advantages of high flexibility in inlet block schemes, combined with the reliability and simplicity of monoblock spool valve construction, eliminating the risk of spools blocking due to overtightening of tie rods or the risk of leakage between sections. The spool monoblock is a 2 or 3 position, 4 ways, direct acting solenoid operated type. All sections have threaded ports at the top and removable plugs for tank connections to allow the installation of flanged blocks with additional functions like crossover reliefs, reliefs to tank, relief and anticavitations, counterbalance valves, P.O. checks, flow restrictors and flow regulators. All sections are equipped with standard push button override and they can be equipped with lever for manual use.

HOW ORDER IT

To order the separate parts please refer to each catalogue page.

To order an assembled block, contact AFT sales network specifying the part numbers following page 19.90.900 path.

For special versions please contact AFT sales network.

EBP series - INLET SECTION

SFPL-060-ZNNN-16

**P, T PORTS
M PORTS**

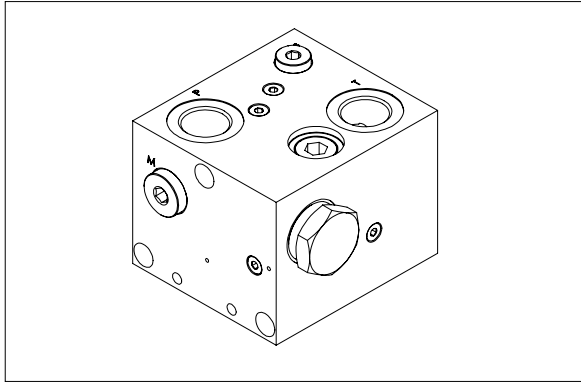

HYDRAULIC SCHEME

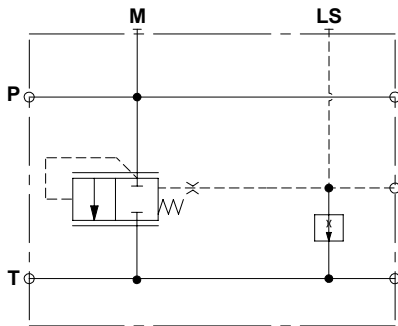

This inlet section is equipped with two thread ports (P,T) available in two different types G 1/2" or 3/4"-16 UNF plus a third threaded port M for pressure measuring available in G 1/4" or 7/16"-20. The manifold material is aluminium for applications up to 210 bar or zinc plated steel for applications up to 320 bar.

TECHNICAL DATA

Max pressure	210/320 bar
Rated flow	60 l/min
Hydraulic fluid	Mineral oil DIN 51524
Fluid viscosity	10-500 mm ² /s
Fluid temperature	-25°C/75°C
Environment temperature	-25°C/60°C
Weight	1,2 Kg

PRESSURE DROP LOGIC ELEMENT

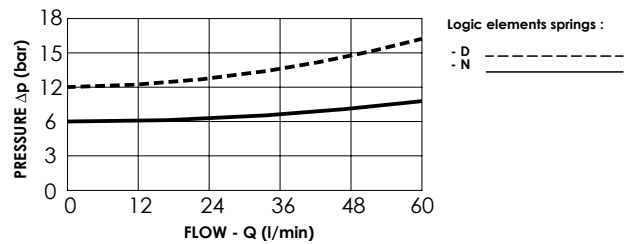

ORDERING DETAILS: SEPARATE ELEMENTS

SFPL-060- * * NN-16 - * -N**

*	MATERIAL TYPE
A	Steel zinc-plated (320 bar)
Z	Aluminium anodized (210 bar)

*	LOGIC ELEMENT SPRING
D	Spring setting 12 bar (CD000103)
N	Spring setting 6 bar (CD000073)

***	PORTS		
	P line	T line	M
G12	G 1/2"	G 1/2"	G 1/4"
U34	3/4"-16 UNF	3/4"-16 UNF	7/16"-20 UNF

QUICK CODE	
DESCRIPTION	CODE
SFPL-060-ZNNN-16-G12-N	SF000048

OVERALL DIMENSIONS

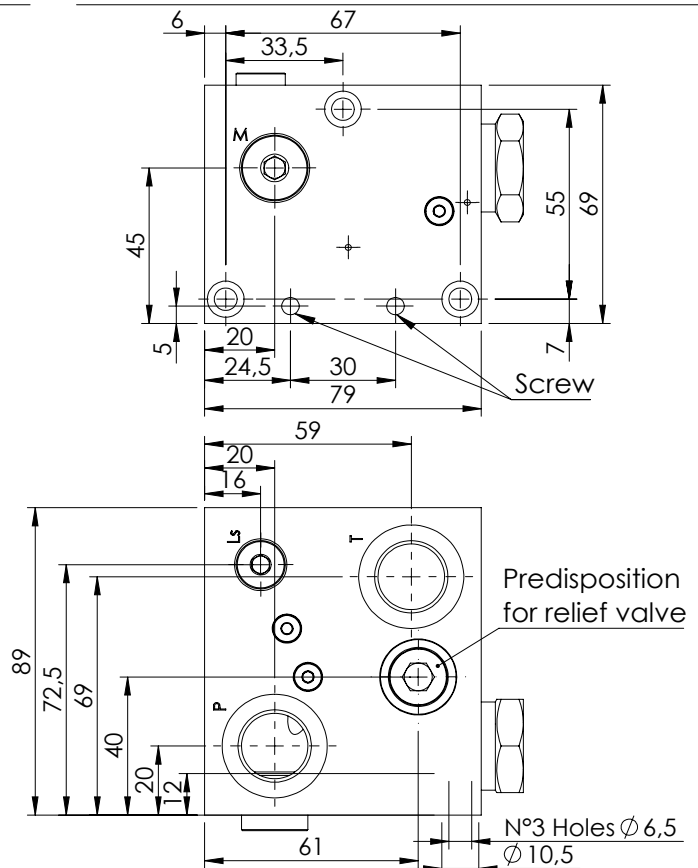

EBP series - INLET SECTION

SFPL-060-ZNNN-17

**RELIEF VALVE
M PORTS**

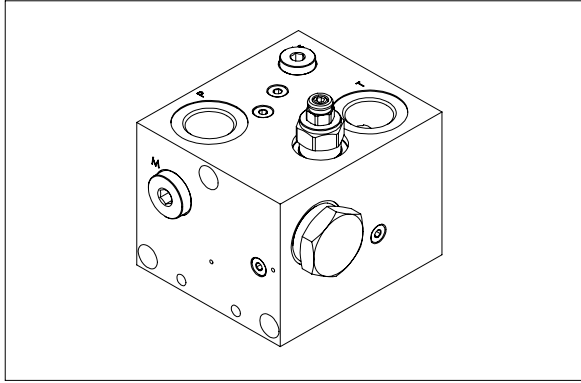

HYDRAULIC SCHEME

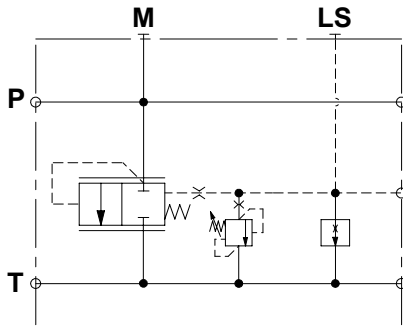

This inlet section is equipped with relief valve with adjustable setting operating on Ls signal, the adjustment is made by socket screw. This inlet section is equipped with two thread ports (P,T) available in two different types G 1/2" or 3/4"-16 UNF plus a third threaded port M for pressure measuring available in G 1/4" or 7/16"-20. The manifold material is aluminium for applications up to 210 bar or zinc plated steel for applications up to 320 bar.

TECHNICAL DATA

Max pressure	210/320 bar
Rated flow	60 l/min
Hydraulic fluid	Mineral oil DIN 51524
Fluid viscosity	10-500 mm ² /s
Fluid temperature	-25°C/75°C
Environment temperature	-25°C/60°C
Weight	1,3 Kg

PRESSURE DROP LOGIC ELEMENT

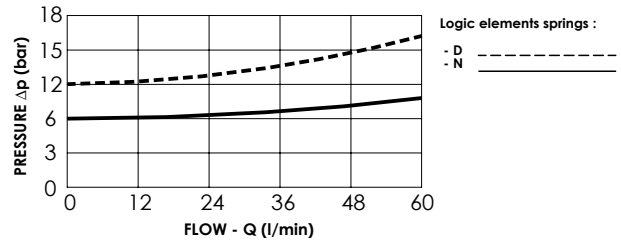

ORDERING DETAILS: SEPARATE ELEMENTS

SFPL-060-*N-17-***-N**

*	MATERIAL TYPE
A	Steel zinc-plated (310 bar)
Z	Aluminium anodized (210 bar)

*	LOGIC ELEMENT SPRING
D	Spring setting 12 bar (CD000103)
N	Spring setting 6 bar (CD000073)

*	SETTING RANGE
N	Max setting 210 bar (CP000029)
A	Max setting 110 bar (CP000030)
B	Max setting 350 bar (CP000002)

***	PORTS		
	P line	T line	M
G12	G 1/2"	G 1/2"	G 1/4"
U34	3/4"-16 UNF	3/4"-16 UNF	7/16"-20 UNF

QUICK CODE	
DESCRIPTION	CODE
SFPL-060-ZNNN-17-G12-N	SF000047

OVERALL DIMENSIONS

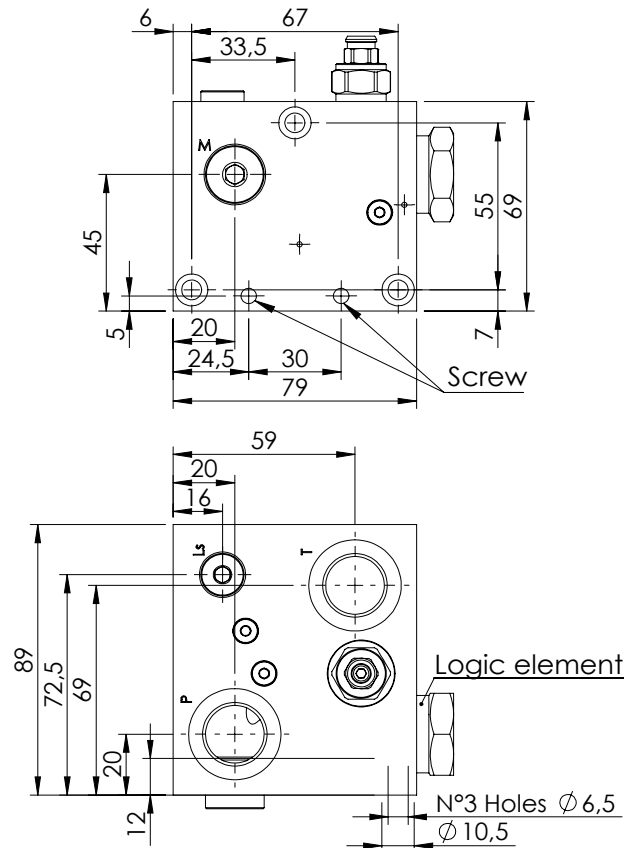

EBP series - INLET SECTION

SFPL-060-ZNNN-19

**RELIEF VALVE
UNLOADING VALVE**

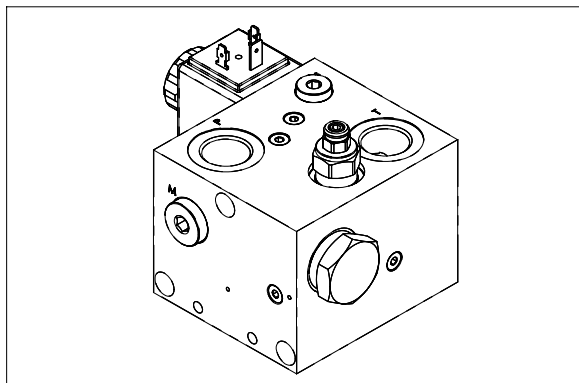

HYDRAULIC SCHEME

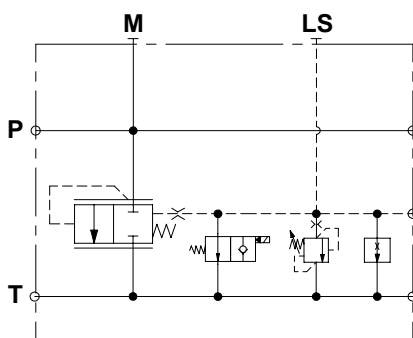

This inlet section is equipped with relief valve with adjustable setting operating on Ls signal, the adjustment is made by socket screw. It is present an unloading solenoid valve normally open with emergency operating on Ls signal. There are two thread ports (P, T) available in two different types G 1/2" or 3/4"-16 UNF plus M port available in G 1/4". Max inlet flow 60 l/min. The manifold material is aluminium for applications up to 210 bar or zinc plated steel for applications up to 320 bar.

TECHNICAL DATA

Max pressure	210/320 bar
Rated flow	60 l/min
Hydraulic fluid	Mineral oil DIN 51524
Fluid viscosity	10-500 mm ² /s
Fluid temperature	-25°C/75°C
Environment temperature	-25°C/60°C
Weight	1,4 Kg

PRESSURE DROP LOGIC ELEMENT

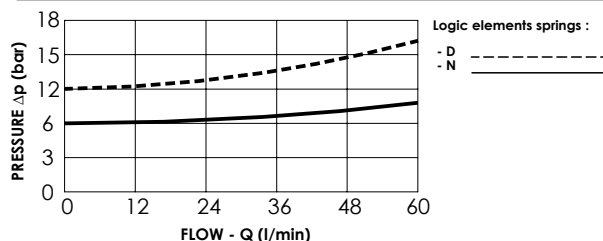

ORDERING DETAILS: SEPARATE ELEMENTS

SFPL-060-*N-19-***-***N**

*	MATERIAL TYPE		
A	Steel zinc-plated	(320 bar)	
Z	Aluminium anodized	(210 bar)	
*	LOGIC ELEMENT SPRING		
D	Spring setting	12 bar (CD000103)	
N	Spring setting	6 bar (CD000073)	
*	SETTING RANGE		
N	Max setting	210 bar (CP000029)	
A	Max setting	110 bar (CP000030)	
B	Max setting	350 bar (CP000002)	
***	PORTS		
	P line	T line	M
G12	G 1/2"	G 1/2"	G 1/4"
U34	3/4"-16 UNF	3/4"-16 UNF	7/16"-20 UNF
*	VOLTAGE		
	no coils		
A	12 V DC		
B	24 V DC		
**	COILS TYPE		
	no coils		
HR	Hirshmann (ISO 4400 DIN 43650)		
DT	Deutsch (DT04-2P)		
AJ	Amp junior (AJ type)		
	QUICK CODE		
	DESCRIPTION	CODE	
	SFPL-060-ZNNN-19-G12-N	SF000046	
	Unloading valve	CE000873	

OVERALL DIMENSIONS

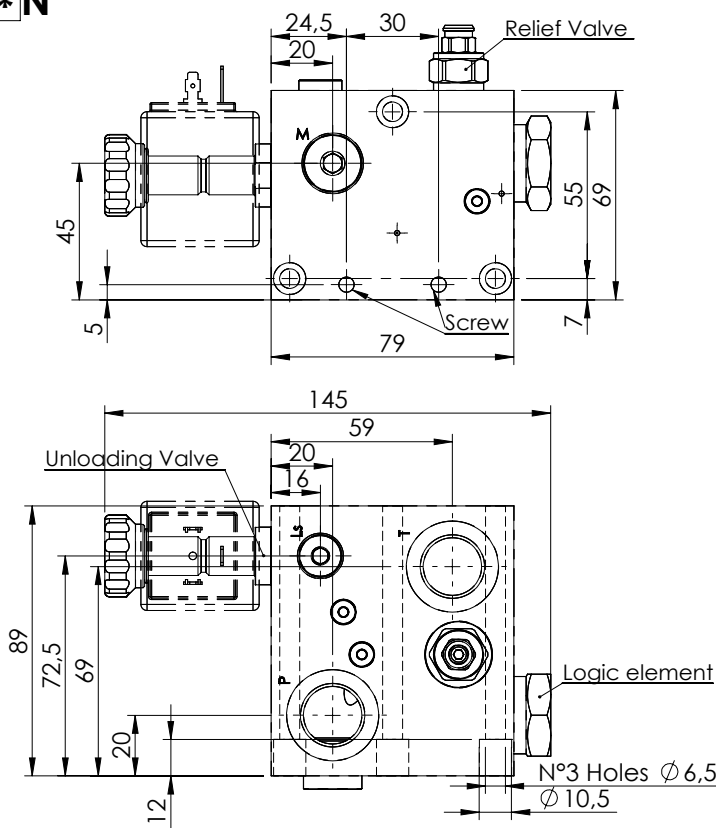

EBP series - INLET SECTION

SFPL-060-ZNNN-20

RELIEF VALVE UNLOADING VALVE WITH EXTERNAL OR INTERNAL LS

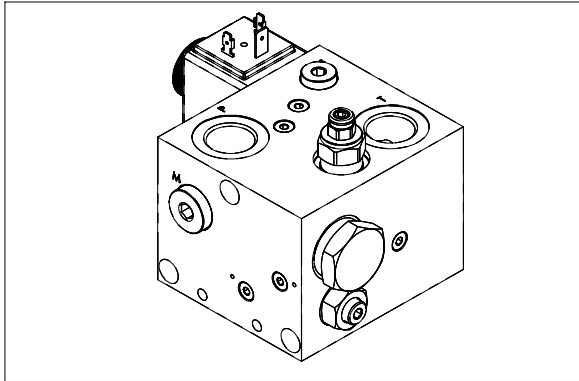

This inlet section is equipped with relief valve with adjustable setting operating on Ls signal, the adjustment is made by socket screw. It is present an unloading compensator normally closed operating with Ls signal. There are two thread ports (P, T) available in two different types G 1/2" or 3/4"-16 UNF plus M port available in G 1/4". Max inlet flow 60 l/min. The manifold material is aluminium for applications up to 210 bar or zinc plated steel for applications up to 320 bar.

HYDRAULIC SCHEME

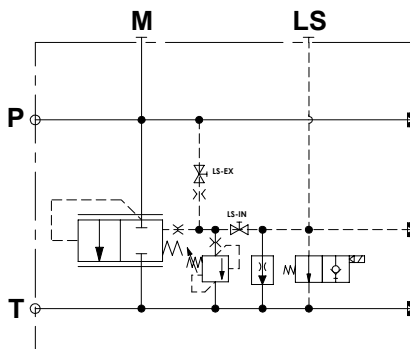

TECHNICAL DATA

Max pressure	210/320 bar
Rated flow	60 l/min
Hydraulic fluid	Mineral oil DIN 51524
Fluid viscosity	10-500 mm ² /s
Fluid temperature	-25°C/75°C
Environment temperature	-25°C/60°C
Weight	1,4 Kg

PRESSURE DROP LOGIC ELEMENT

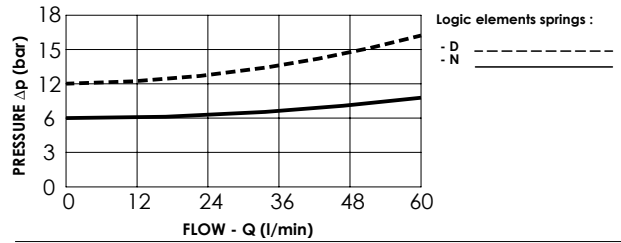

ORDERING DETAILS: SEPARATE ELEMENTS

SFPL-060-*N-20-***-***N**

* MATERIAL TYPE	
A	Steel zinc-plated (320 bar)
Z	Aluminium anodized (210 bar)
* LOGIC ELEMENT SPRING	
D	Spring setting 12 bar (CD000103)
N	Spring setting 6 bar (CD000073)
* SETTING RANGE	
N	Max setting 210 bar (CP000029)
A	Max setting 110 bar (CP000030)
B	Max setting 350 bar (CP000002)
*** PORTS	
	P line T line M
G12	G 1/2" G 1/2" G 1/4"
U34	3/4"-16 UNF 3/4"-16 UNF 7/16"-20 UNF
* VOLTAGE	
	no coils
A	12 V DC
B	24 V DC
** COILS TYPE	
	no coils
HR	Hirshmann (ISO 4400 DIN 43650)
DT	Deutsch (DT04-2P)
AJ	Amp junior (AJ type)
QUICK CODE	
DESCRIPTION	CODE
SFPL-060-ZNNN-20-G12-N	SF000041
Unloading valve	CE000873

OVERALL DIMENSIONS

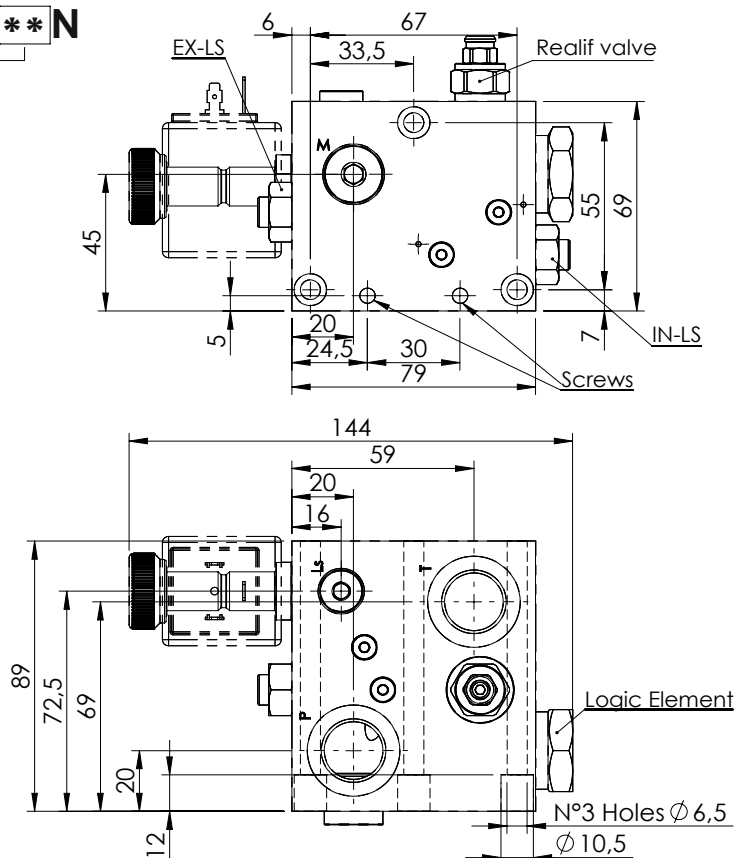

In LDPP/S-060-C plug are included in the manifold

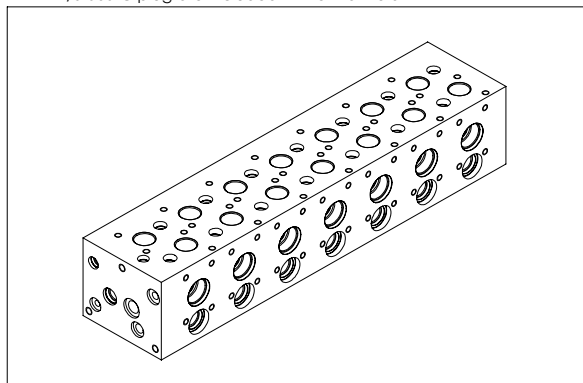

The manifold's valve can be ordered with 3 types of ports for connection nipples G 3/8" 9/16"-18 UNF (SAE6) and M16x1,5. Standard version is G 3/8" for other type of ports we will mounting flangiabe elemtens it change G 3/8" to 9/16"-18 UNF (SAE6) or M16x1,5 (can look that in dimension drawing). Manifold it's made in cast-iron with zinc-plated (black) surface treatment with sealant. It isn't a modular block for reduce to minimun the leakage through the section and also for haven't problem with screw torque. Also can easely open, removing plug, extra T connection for different kind of use such as modular valve flangiabe on distributor.

TECHNICAL DATA

Max pressure	320 bar
Rated flow	60 l/min
Material	Cast-iron
Surface treatment	Zinc-plated black
Weight for single section	2,5 kg
Wight for additional sections	+ 1,5 Kg each

ORDERING DETAILS: SEPARATE ELEMENTS

LDP * - 060-NNNN - ** - ***

*	TYPE OF MANIFOLD
S	Series connection
P	Parallel connection

**	NUMBER OF SECTION
01	manifold with one section
02	manifold with two sections
03	manifold with three sections
04	manifold with four sections
05	manifold with five sections
06	manifold with six sections
07	manifold with seven sections

***	PORTS		
	P line	T line	M
G38	G 3/8"	G 3/8"	G 1/4"
U09	9/16"-18 UNF	9/16"-18 UNF	7/16"-20 UNF

QUICK CODE	
DESCRIPTION	CODE
LDPP-060-NNNN-01-G12	LD000289
LDPP-060-NNNN-02-G12	LD000293
LDPP-060-NNNN-03-G12	LD000292
LDPP-060-NNNN-04-G12	LD000291
LDPP-060-NNNN-05-G12	LD000290
LDPP-060-NNNN-06-G12	LD000279
LDPP-060-NNNN-07-G12	LD000284

MANIFOLD CONFIGURATIONS

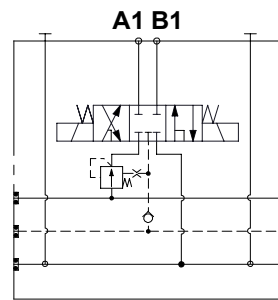

LDPP-060

MONOBLOCK PRESSURE DROP

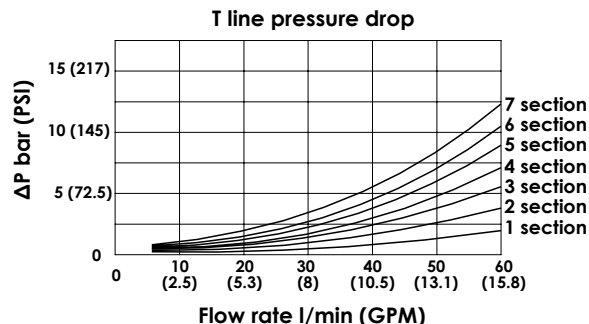
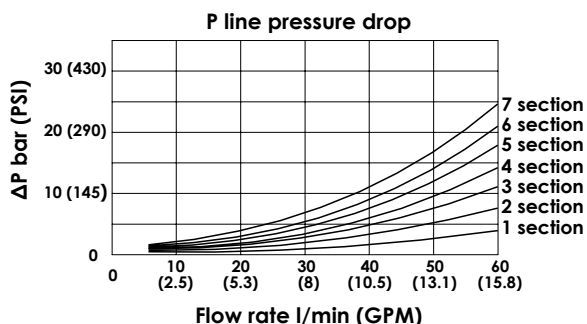

LDPP-060-NNNN

**CAST-IRON
MANIFOLD**

GAS VERSION

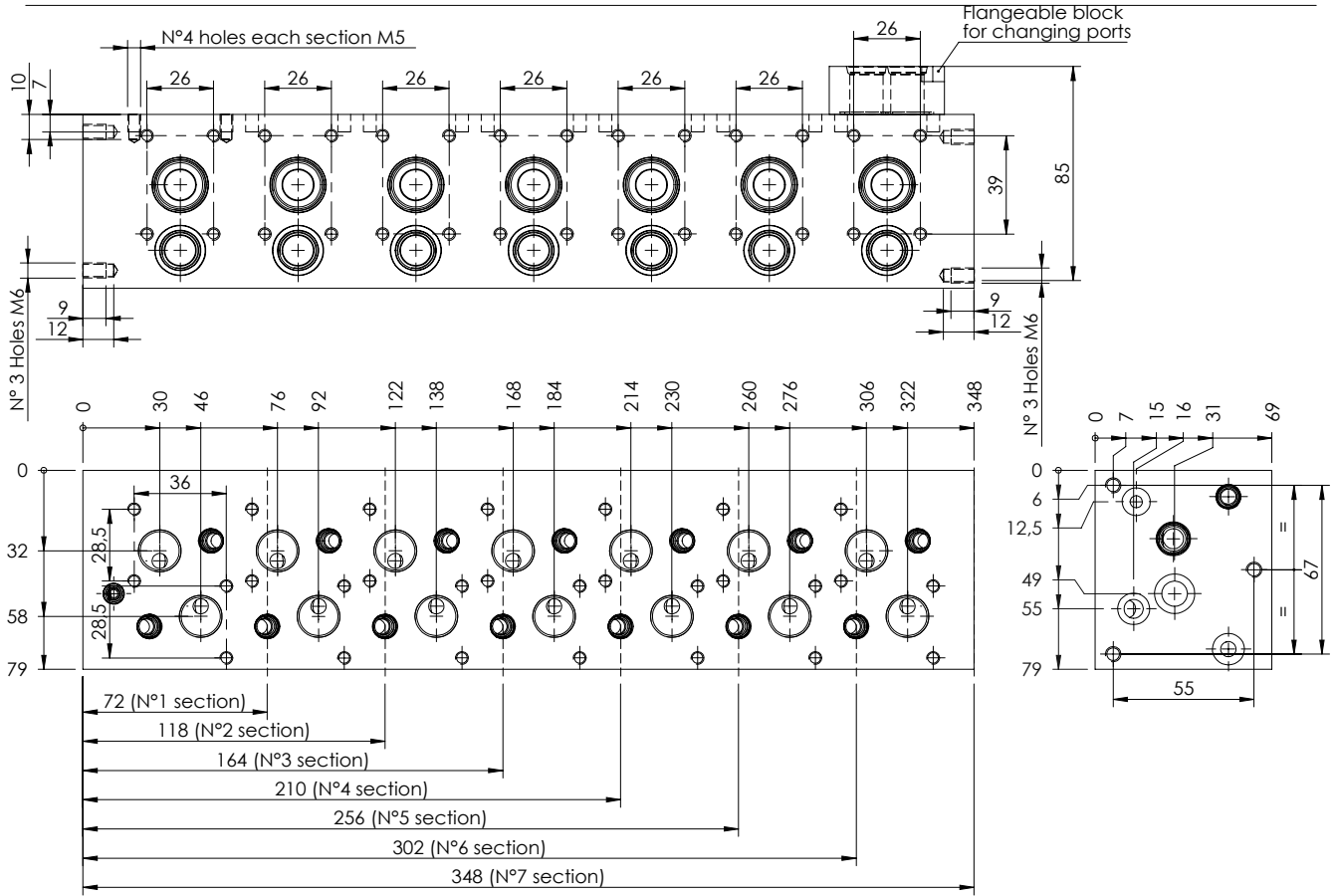

SAE VERSION

METRIC VERSION

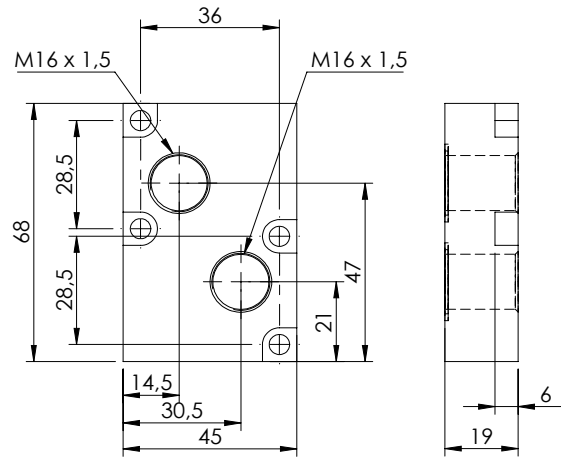
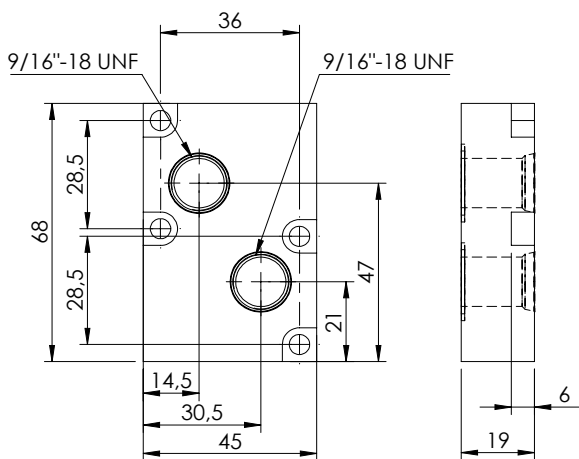

This top flangeable block transform the monoblock to a UNF version.

This top flangeable block transform the monoblock to a Metric version.

Quick code: MP000096

Quick code: MP000097

EBP series - SPOOL SECTION

SHNE-030-LSON

**30 L/MIN
SOLENOID VALVE**

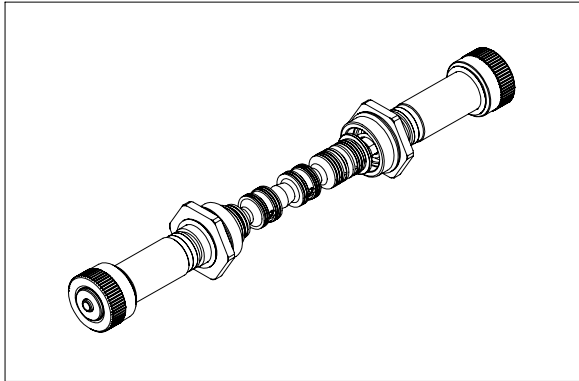

This spool group is rated for 30 lpm and for a maximum pressure of 320 bar; the spool is actuated by on off tubes and can be ordered with different hydraulic schemes. Each spools is interchangeable to give maximum flexibility and can be fit in all monoblock sections, changing spools require adequate training. The group is made by two tubes, one spool, two springs and mounting components.

TECHNICAL DATA

Max pressure	320 bar
Rated flow	30 l/min
Max excitation frequency	3 Hz
Duty cycle	100 % ED
Hydraulic fluid	Mineral oil DIN 51 524
Fluid viscosity	10/500 mm ² /s
Fluid temperature	-25°C/75°C
Enviroment temperature	-25°C/60°C
Weight with one solenoid	0,12 Kg
Weight with two solenoid	0,15 kg

ORDERING DETAILS: SEPARATE ELEMENTS

SH - 030 - LS ** - ** - 396 - ** N**

*	VERRIDE TYPE
N	Standard
P	Push
V	Screw

*	SECTION TYPE
E	Solenoid operated
L	Solenoid operated plus lever operated
M	Lever operated

**	ACTUATION TYPE
ON	On/Off
SS	Soft shift

**	SPOOL TYPE
...	See table n°1

*	COILS VOLTAGE
	no coils
A	12 V DC
B	24 V DC

**	COILS TYPE
	no coils
HR	Hirschmann (ISO 4400 DIN 43650)
DT	Deutshc (DT04-2P)
AJ	Amp Junior (AJ type)

QUICK CODE	
DESCRIPTION	CODE
SHNE-030-LSON-74-396	
SHNE-030-LSON-75-396	

HYDRAULIC SYMBOLS

Table n°1

SPOOL CODE	HYDRAULIC SCHEME	TRANSITORY POSITION
74		
75		
SPOOL CODE	HYDRAULIC SCHEME	TRANSITORY POSITION
a	b	a
		b

VERRIDE TYPE

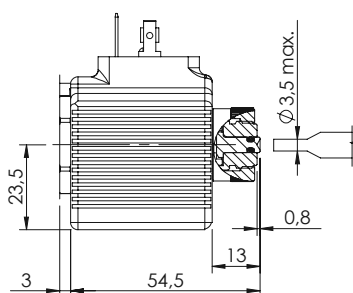

VERRIDE TYPE "N"

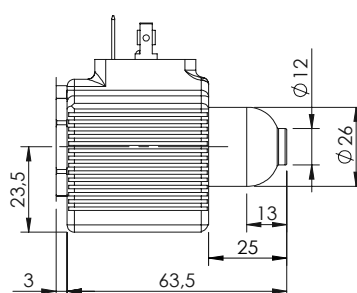

VERRIDE TYPE "P"

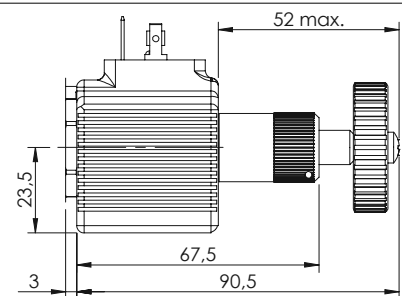

VERRIDE TYPE "V"

SHNE-030-LSON

30 L/MIN SOLENOID VALVE

PERFORMANCE LIMITS CURVES - STANDARD SECTION

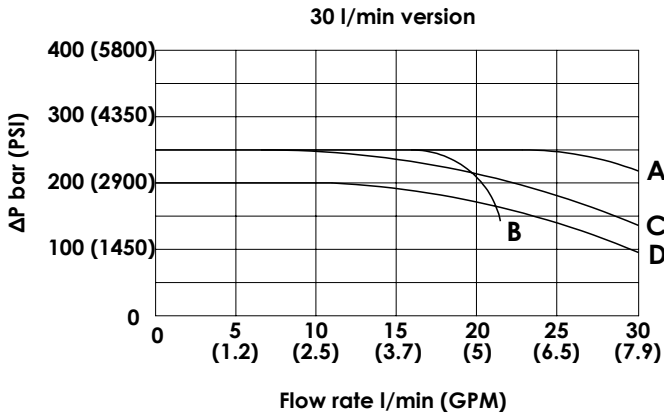

Spool type	Performance limits curve
74	A
75	A
	B
	A
	A
	A
	C
	D

The tests are carried out with hot solenoids, powered with 90% of nominal voltage, with 50 °C fluid temperature. The fluid used is mineral oil having a viscosity of 46 mm² / s @ 40 °C.

The values in the diagram refer to tests carried out with flow simultaneously in both directions (P > A, B > T).

In cases of schemes 4/2 or 4/3 used with the flow in one direction only the performance can change.

PRESSURE DROP CURVES - STANDARD SECTION

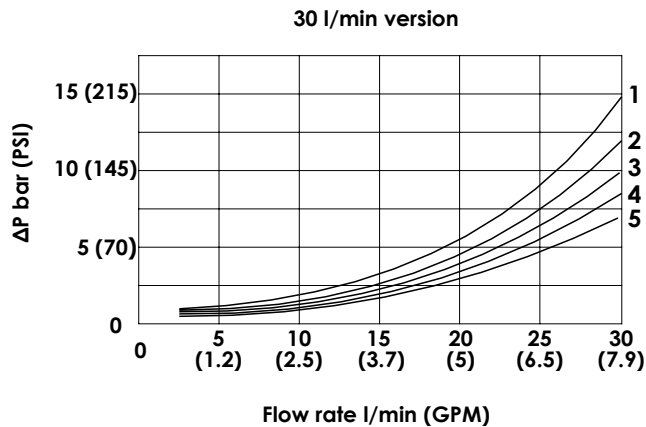

Spool type	Pressure drop curve				
	P>A	P>B	A>T	B>T	P>T
74	3	3	4	4	/
75	3	3	5	5	/
	2	2	1	1	2
	/	3	4	/	/
	/	3	5	/	/
	2	/	/	1	/
	/	3	4	/	/
	/	2	3	/	/

The diagram shows the performance limit curve of standard section. The fluid used is mineral oil viscosity 46 mm²/s at 40 °C ; the tests are performed at a 40 °C temperature

OVERALL DIMENSION - STANDARD SECTION

In case of top modular valve MA or MC type installation the coil connection can be faced to the top or to the bottom of the block. (See modular valve section)

In case of top modular valve MB, KE and KF type installation the coil connection can be faced only to the bottom of the block. (See modular valve section)

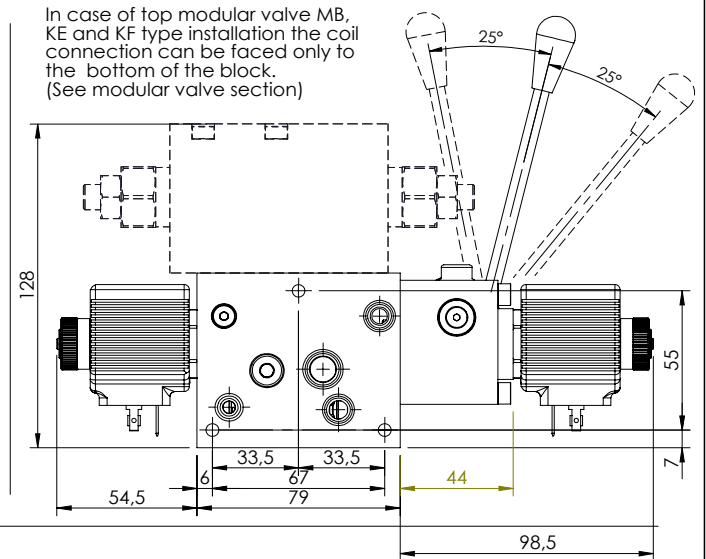
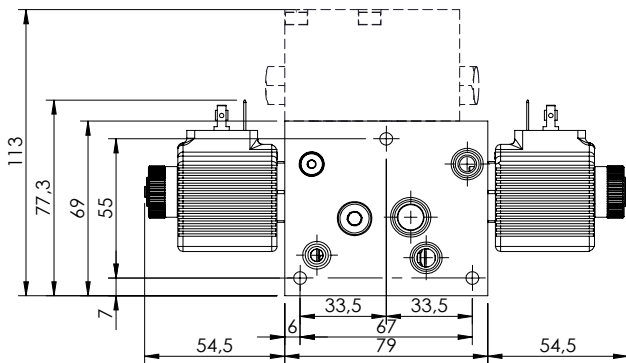

SHNE-060-LSON

60 L/MIN
SOLENOID VALVE

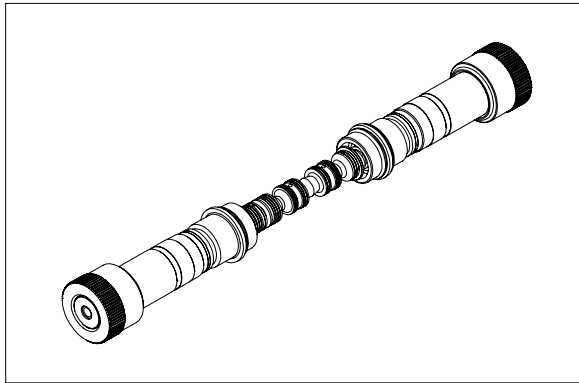

This spool group is rated for 60 lpm and for a maximum pressure of 320 bar; the spool is actuated by on off tubes and can be ordered with different hydraulic schemes. Each spools is interchangeable to give maximum flexibility and can be fit in all monoblock sections, changing spools require adequate training. The group is made by two tubes, one spool, two springs and mounting components.

TECHNICAL DATA

Max pressure	320 bar
Rated flow	60 l/min
Max excitation frequency	3 Hz
Duty cycle	100 % ED
Hydraulic fluid	Mineral oil DIN 51524
Fluid viscosity	10/500 mm ² /s
Fluid temperature	-25°C/75°C
Enviroment temperature	-25°C/60°C
Weight with one solenoid	0,2 Kg
Weight with two solenoid	0,4 kg

ORDERING DETAILS: SEPARATE ELEMENTS

SH** - 060 - LS** - ** - 396 - ** * N

*	VERRIDE TYPE
N	Standard
P	Push
V	Screw

*	SECTION TYPE
E	Solenoid operated
L	Solenoid operated plus lever operated
M	Lever operated

**	ACTUATION TYPE
ON	On/Off
SS	Soft shift

**	SPOOL TYPE
...	See table n°1

*	COILS VOLTAGE
	no coils
A	12 V DC
B	24 V DC

**	COILS TYPE
	no coils
HR	Hirschmann (ISO 4400 DIN 43650)
DT	Deutshc (DT04-2P)
AJ	Amp Junior (AJ type)

QUICK CODE	
DESCRIPTION	CODE
SHNE-060-LSON-74-396	
SHNE-060-LSON-75-396	

HYDRAULIC SYMBOLS

Table n°1

SPOOL CODE	HYDRAULIC SCHEME	TRANSITORY POSITION
74		
75		
SPOOL CODE	HYDRAULIC SCHEME	TRANSITORY POSITION
a b	a b	a b

VERRIDE TYPE

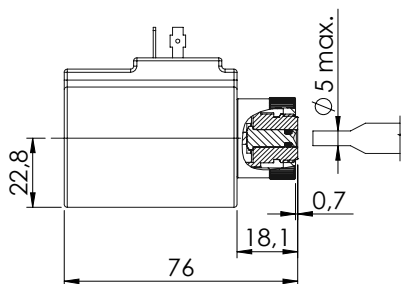

VERRIDE TYPE "N"

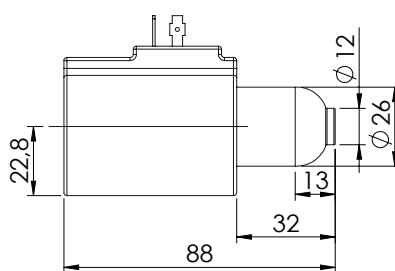

VERRIDE TYPE "P"

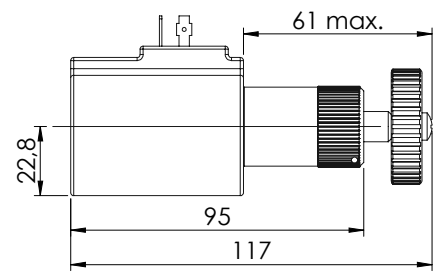

VERRIDE TYPE "V"

PERFORMANCE LIMIT CURVES - STANDARD SECTION

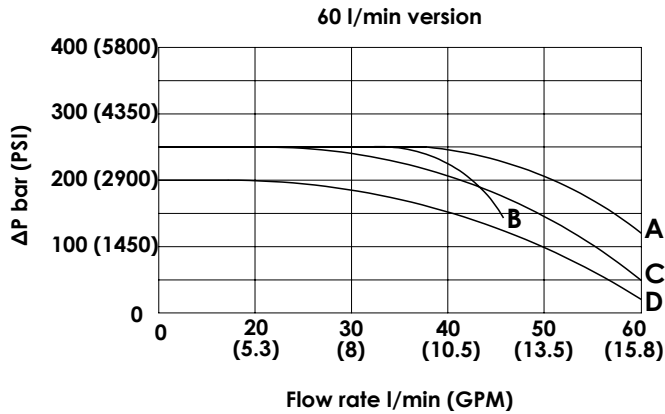

Spool type	Performance limits curve
74	A
75	A
	B
	A
	A
	A
	C
	D

The tests are carried out with hot solenoids , powered with 90 % of nominal voltage , with 50 ° C fluid temperature. The fluid used is mineral oil having a viscosity of 46 mm² / s @ 40 ° C .

The values in the diagram refer to tests carried out with flow simultaneously in both directions (P > A , B > T).

In cases of schemes 4/2 or 4/3 used with the flow in one direction only the performance can change.

PRESSURE DROP CURVES - STANDARD SECTION

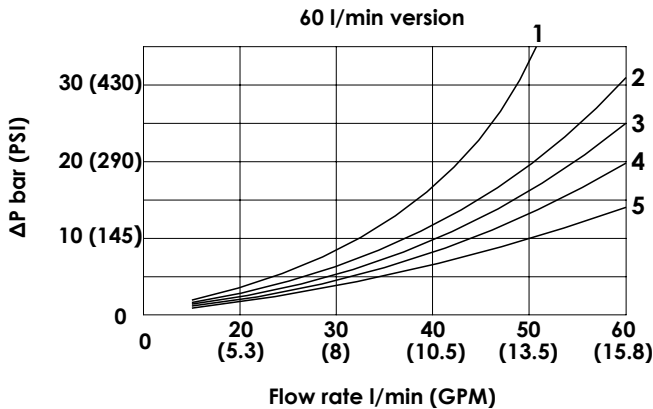

Spool type	Pressure drop curve				
	P>A	P>B	A>T	B>T	P>T
74	3	3	4	4	/
75	3	3	5	5	/
	2	2	1	1	2
	/	3	4	/	/
	/	3	5	/	/
	2	/	/	1	/
	/	3	4	/	/
	/	2	3	/	/

The diagram shows the performance limit curve of standard section. The fluid used is mineral oil viscosity 46 mm²/s at 40 °C ; the tests are performed at a 40 °C temperature

OVERALL DIMENSION - STANDARD SECTION

In case of top modular valve MA or MC type installation the coil connection can be faced to the top or to the bottom of the block. (See modular valve section)

In case of top modular valve MB, KE and KF type installation the coil connection can be faced only to the bottom of the block. (See modular valve section)

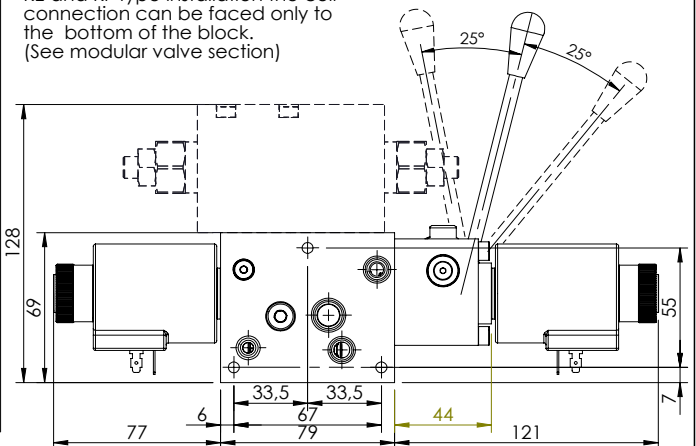
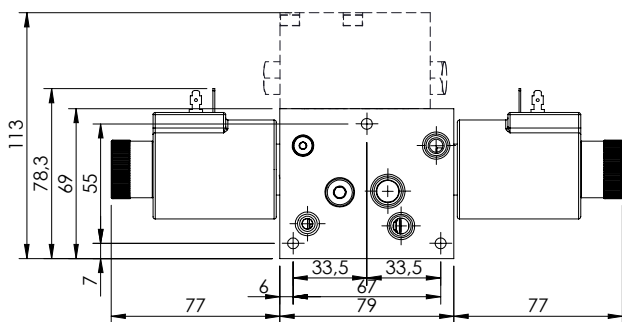

SHNE-050-LSPR

50 L/MIN
PROPORTIONAL
SOLENOID VALVE

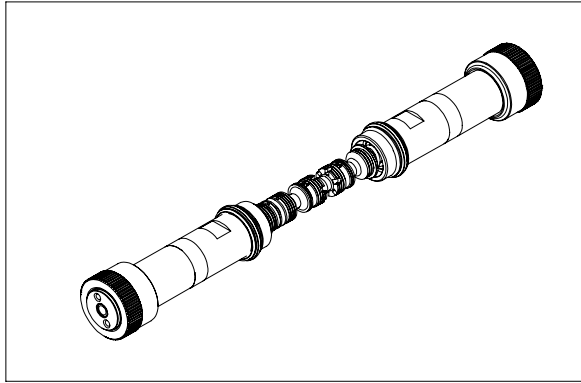

This spool group is rated for 50 lpm and for a maximum pressure of 320 bar; the spool is actuated by proportional tubes and can be ordered with different hydraulic schemes. Each spools is interchangeable to give maximum flexibility and can be fit in all monoblock sections, changing spools require adequate training. The group is made by two tubes, one spool, two springs and mounting components.

TECHNICAL DATA

Max pressure	320 bar
Rated flow	50 l/min
Max excitation frequency	3 Hz
Duty cycle	100 % ED
Max current	1.76A (12 V dc) 0.88A (24 V dc)
Hydraulic fluid	Mineral oil DIN 51524
Fluid viscosity	10/500 mm ² /s
Fluid temperature	-25°C/75°C
Environment temperature	-25°C/60°C
Weight with one solenoid	0,2 Kg
Weight with two solenoid	0,4 kg

ORDERING DETAILS: SEPARATE ELEMENTS

SH** - 0** - LSPR - ** - 396 - ***N

*	VERRIDE TYPE
N	Standard
P	Push
V	Screw

*	SECTION TYPE
E	Solenoid operated
L	Solenoid operated plus lever operated
M	Lever operated

**	SPOOL FLOW
20	20 l/min at 12 bar - 10 l/min at 6 bar
35	35 l/min at 12 bar - 20 l/min at 6 bar
50	50 l/min at 12 bar - 30 l/min at 6 bar

**	SPOOL TYPE
...	See table n°1

*	COILS VOLTAGE
	no coils
A	12 V DC
B	24 V DC

**	COILS TYPE
	no coils
HR	Hirschmann (ISO 4400 DIN 43650)
DT	Deutshc (DT04-2P)
AJ	Amp Junior (AJ type)

QUICK CODE	
DESCRIPTION	CODE
SHNE-030-LSPR-77-396	
SHNE-030-LSPR-78-396	

TECHNICAL FEATURES

Proportionl type	Spool flow	Rated flow with 12 bar ΔP	Maximum flow	Max. operating pressure
All	20	15	20	320
All	35	30	35	320
All	50	45	50	320

Proportionl type	Spool flow	Rated flow with 6 bar ΔP	Maximum flow	Max. operating pressure
All	20	10	15	320
All	35	20	25	320
All	50	30	35	320

HYDRAULIC SYMBOLS

Table n°1

SPOOL CODE	HYDRAULIC SCHEME	TRANSITORY POSITION
77		
78		

VERRIDE TYPE

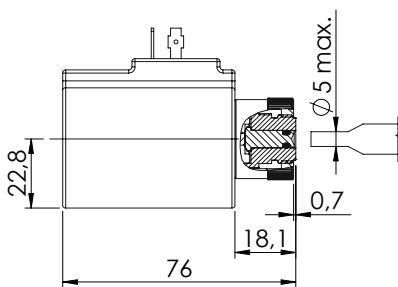

VERRIDE TYPE "N"

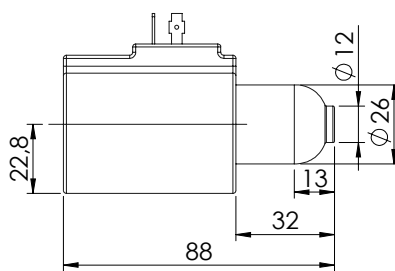

VERRIDE TYPE "P"

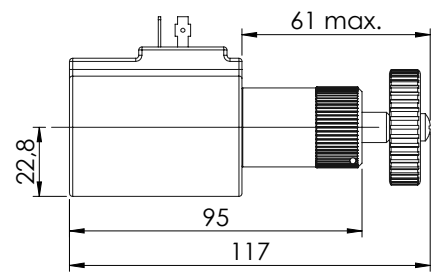

VERRIDE TYPE "V"

SHNE-050-LSPR

50 L/MIN
PROPORTIONAL
SOLENOID VALVE

FLOW DIAGRAM - 050

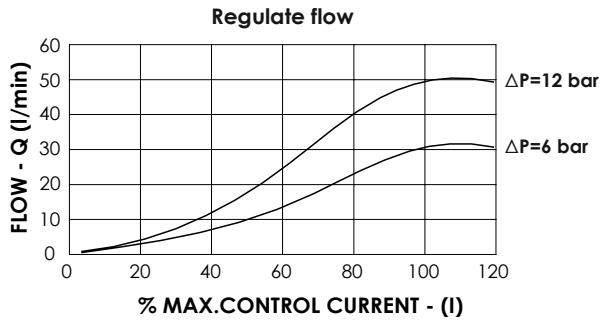

COMPESATION DIAGRAM - 050

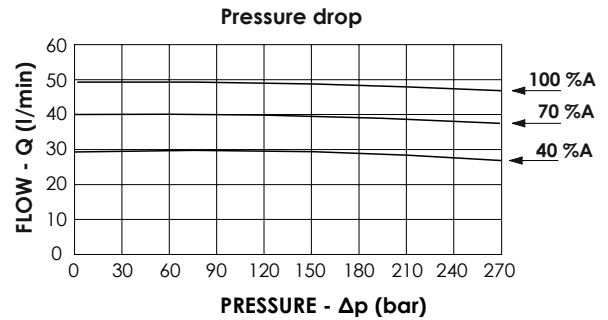

FLOW DIAGRAM - 035

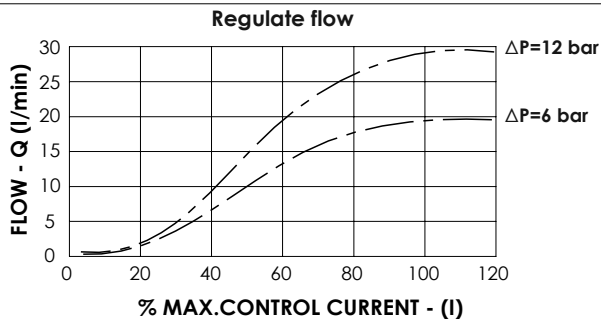

COMPENSATION DIAGRAM - 035

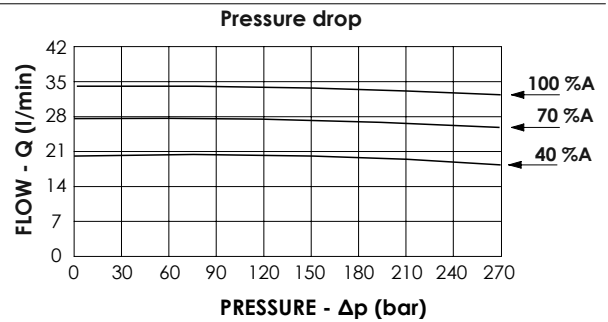

FLOW DIAGRAM - 020

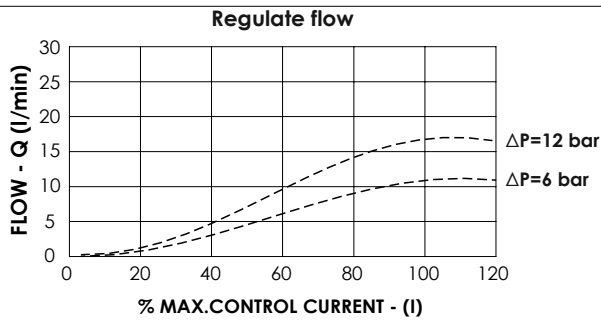

COMPENSATION DIAGRAM - 020

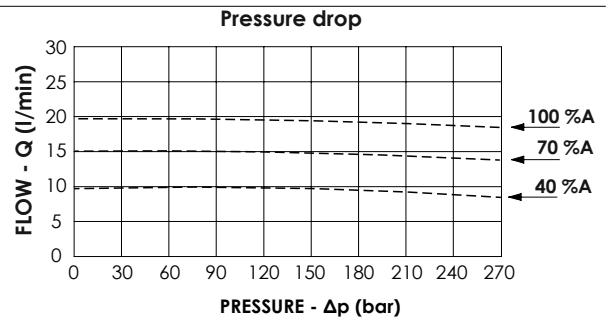

Spool type:

- 10 _____
- 20 _____
- 30 _____

In the diagram shows the performance limits curves of standard section. The fluid used is mineral oil viscosity 46 mm²/s at 40 °C; the tests were performed at a 40 °C temperature

OVERALL DIMENSION - STANDARD SECTION

In case of top modular valve MA or MC type installation the coil connection can be faced to the top or to the bottom of the block. (See modular valve section)

In case of top modular valve MB, KE and KF type installation the coil connection can be faced only to the bottom of the block. (See modular valve section)

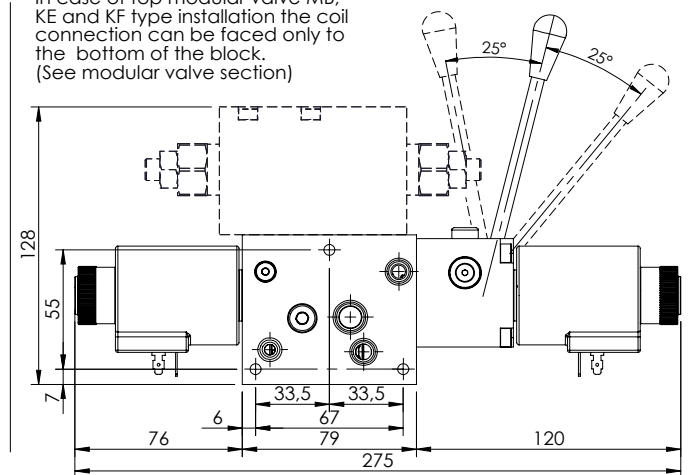
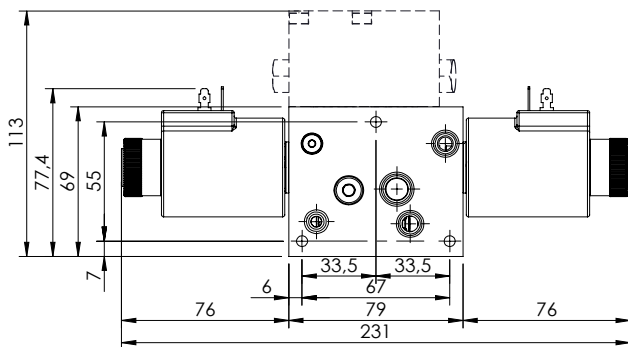

MANUAL LEVER

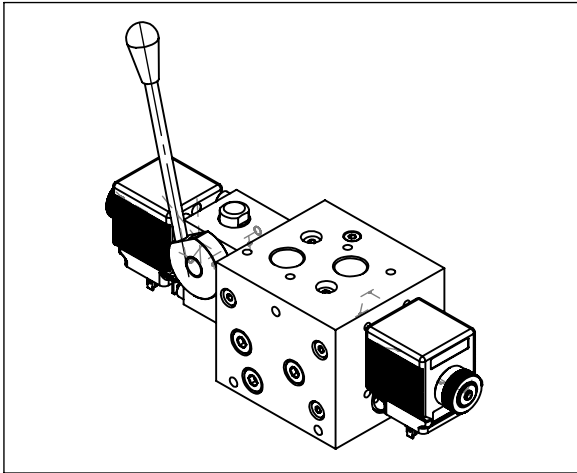

The lever option allow to operate manually the spool and can be ordered for all hydraulic schemes; in the standard version it is installed between monoblock and B port side coil. The lever is normally installed on the monoblock port side but can be installed also rotated of 180°; in each of these two positions the lever can be mounted vertical or horizontal simply removing the lever and reinstalling. The lever is not engaged during solenoid operation and doesn't move when a coil is energized.

TECHNICAL DATA

Max pressure	210/320 bar
Max pressure in line type	210 bar
Rated flow	30/60 l/min
Insertion	100 % ED
Weight more than standard	3 Kg
Weight more than standard	3,5 kg

OVERALL DIMENSIONS/ LEVER FOR 30 L/MIN SECTION

The lever option is designed to activate the spool manually, when the lever is pulled the flow is delivered from the port close to the lever, when it is pushed the flow is delivered from the port opposite to the lever. The standard operation deliver full flow, in case of override operation it is possible to reduce the maximum stroke and consequently the speed, for this option contact AFT sales network. The lever can be easily positioned vertical or horizontal by unscrewing it from the rotating shaft.

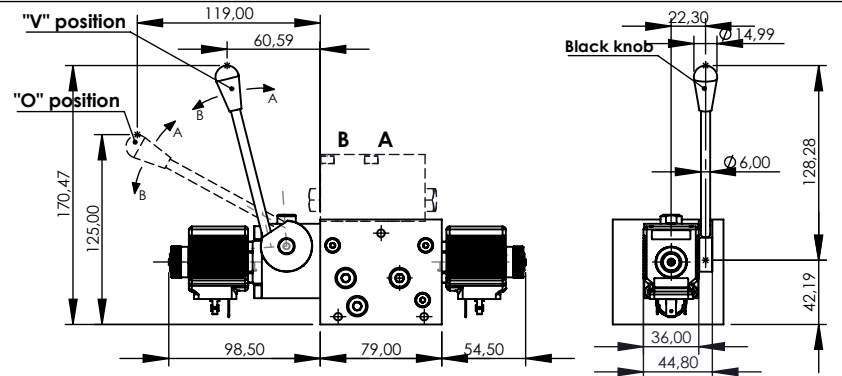

OVERALL DIMENSIONS/ LEVER FOR 60 L/MIN SECTION

The lever option is designed to activate the spool manually, when the lever is pulled the flow is delivered from the port close to the lever, when it is pushed the flow is delivered from the port opposite to the lever. The standard operation deliver full flow, in case of override operation it is possible to reduce the maximum stroke and consequently the speed, for this option contact AFT sales network. The lever can be easily positioned vertical or horizontal by unscrewing it from the rotating shaft.

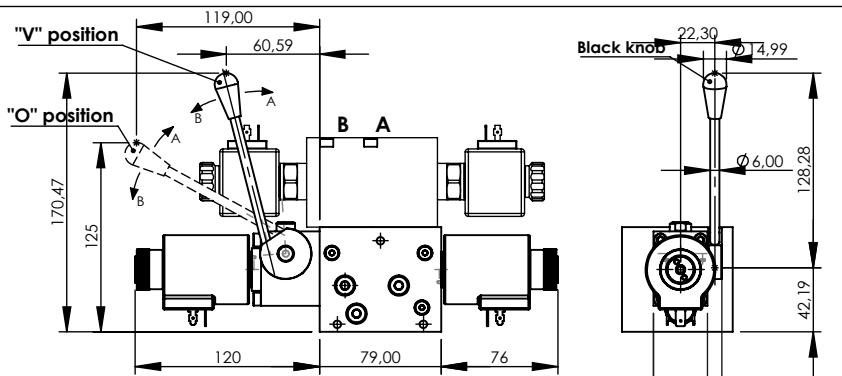

OVERALL DIMENSION/ LEVER FOR 50 L/MIN PROPORTIONAL SECTION

The lever option is designed to activate the spool manually, when the lever is pulled the flow is delivered from the port close to the lever, when it is pushed the flow is delivered from the port opposite to the lever. The standard operation deliver full flow, in case of override operation it is possible to reduce the maximum stroke and consequently the speed, for this option contact AFT sales network. The lever can be easily positioned vertical or horizontal by unscrewing it from the rotating shaft.

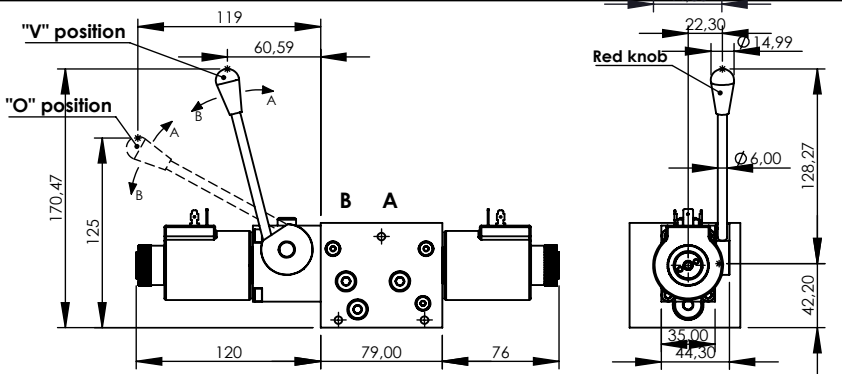

MOUNTING SCREW

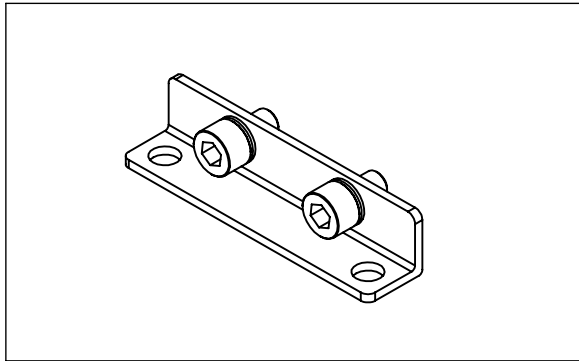

This accessories it use for mounting and fixing distributor on machine, in case the mounting brackets, or for mounting the different componets who assemble the whole distributor.

TECHNICAL DATA

Screw type	ISO 4762
Thread type	coarse thread
Standard screw	resistence class 8.8
High resistance screw	resistence class 12.9
Standard screw treatment	zinc-plated (white)
High res. screw treatment	Anodized (black)

MOUNTING BRACKETS

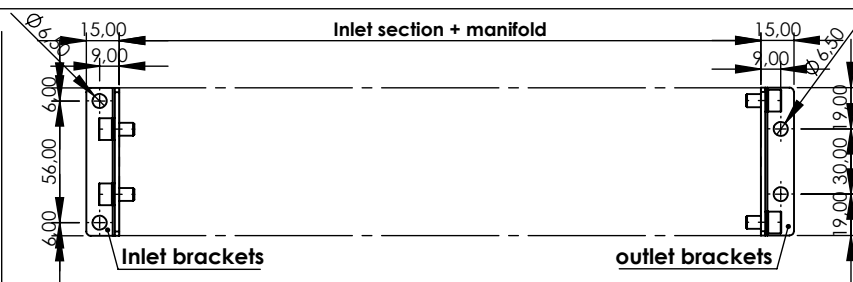
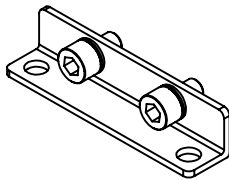

Mounting brackets	Screw lenght (mm)	Reference	Tightening Torque
PV000371	M6x10	AV000015 + PR000129	6 - 7 N/m

MOUNTING INLET SECTION

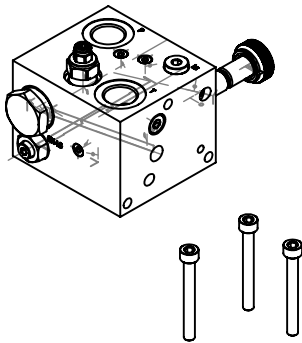

Inlet section	Screw lenght (mm)	Reference	Tightening Torque
SF000048	85	PE000491	6 - 7 N/m
SF000047	85	PE000491	6 - 7 N/m
SF000046	85	PE000491	6 - 7 N/m
SF000041	85	PE000491	6 - 7 N/m

FIXING STACKING MODULES

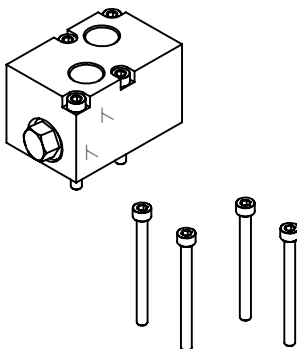

Flangiabile valve	Screw lenght (mm)	Reference	Tightening Torque
MP	M5x16	AV000035	3 - 4 N/m
MA, MC and MB	M5x45	PE000148	3 - 4 N/m
KE and MF	M5x60	AV000016	3 - 4 N/m



1800-OILSOL
1800-645765

<https://oilsolutions.com.au/>

sales@oilsolutions.com.au

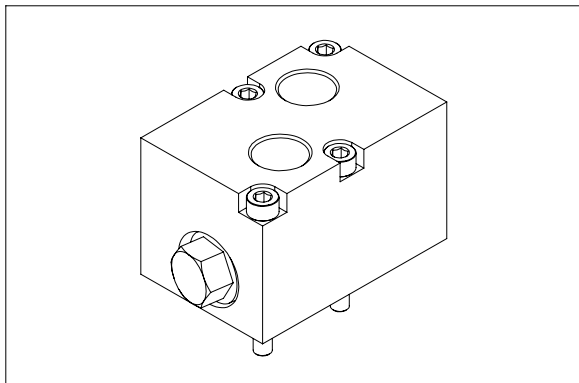

HYDRAULIC SCHEME

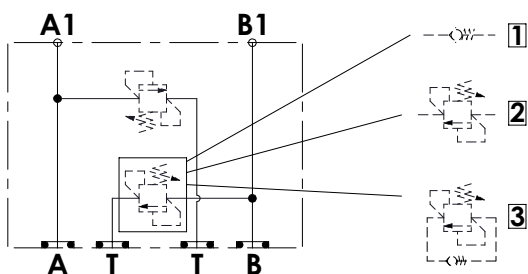

This flangeable valve can be mounted on top of the monoblock after removing the T line plugs; it has different configurations such as anti-shock, anti-cavitation or anti-shock/cavitation. There are three mounting options, single valve on A or on B for single effect operation or valves on A and B for double effect operation. The manifold is made in aluminium with anodization surface treatment or on request in steel with zinc plating treatment.

TECHNICAL DATA

Max pressure	210/320 bar
Rated flow	60 l/min
Hydraulic fluid	Mineral oil DIN 51 524
Fluid viscosity	10-500 mm ² /s
Fluid temperature	-25°C/75°C
Environment temperature	-25°C/60°C
Weight	0,4 Kg

PRESSURE DROP

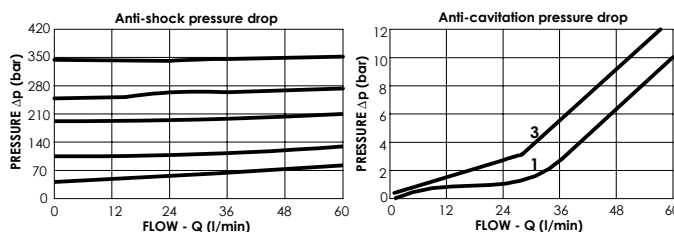

ORDERING DETAILS: SEPARATE ELEMENTS

MA** -060- *NFD- ** -***-N***

* VALVE TYPE	
S	Single effect
D	Double effect

* VALVE OPTION	
N	Valves in both ports
A	Valve only A port
B	Valve only B port

* MATERIAL TYPE	
A	Steel zinc-plated (320 bar)
Z	Aluminium anodized (210 bar)

** VALVE TYPE		
	A line	B line
	no valve	no valve
1	anti-cavitation	anti-cavitation
2	anti-shock	anti-shock
3	anti-cav/shock	anti-cav/shock

*** PORTS			
	A line	B line	M
G38	G 3/8"	G 3/8"	/
U09	9/16"-18 UNF	9/16"-18 UNF	/

* SETTINGS RANGE	
...	10 - 310 bar
../..	For difference A e B setting sign it

QUICK CODE	
DESCRIPTION	CODE

OVERALL DIMENSIONS

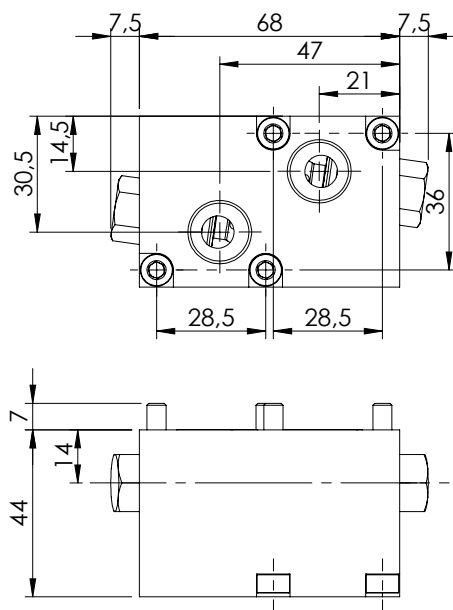

MCDN-060-ZNFD

PO CHECK VALVE FLANGIABLE VALVE

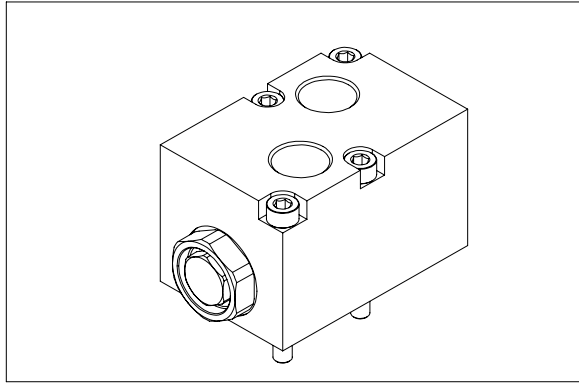

This flangeable valve can be mounted on top of the monoblock keeping the T line plugs.
The valve consist in two pilot operated check piloted by the opposite line and is poppet type.
The manifold is made in aluminium with anodization surface treatment or on request in steel with zinc plating treatment.

HYDRAULIC SCHEME

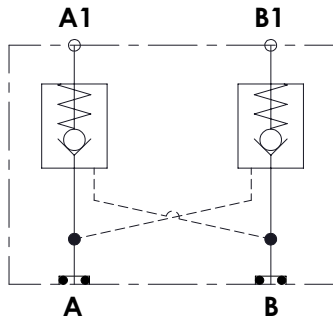

TECHNICAL DATA

Max pressure	210/320 bar
Rated flow	60 l/min
Pilot ratio	6:1
Hydraulic fluid	Mineral oil DIN 51524
Fluid viscosity	10-500 mm ² /s
Fluid temperature	-25°C/75°C
Environment temperature	-25°C/60°C
Weight	0,4 Kg

PRESSURE DROP

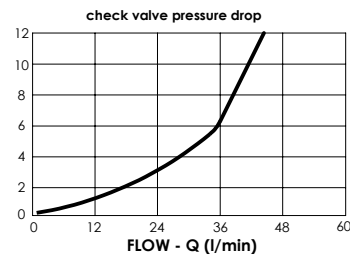

ORDERING DETAILS: SEPARATE ELEMENTS

MC - 060 - * NFD-06-***-N**

*	VALVE TYPE
S	Single effect
D	Double effect

*	VALVE OPTION
N	Check valve on A e B ports
A	Check valve only A port
B	Check valve only B port

*	MATERIAL TYPE
A	Steel zinc-plated (320 bar)
Z	Aluminium anodized (210 bar)

***	PORTS		
	A line	B line	M
G38	G 3/8"	G 3/8"	/
U09	9/16"-18 UNF	9/16"-18 UNF	/

QUICK CODE	
DESCRIPTION	CODE
MCDN-060-ZNFD-06-G38-N210	MC000173
MCSA-060-ZNFD-06-G38-N210	MC000185

OVERALL DIMENSIONS

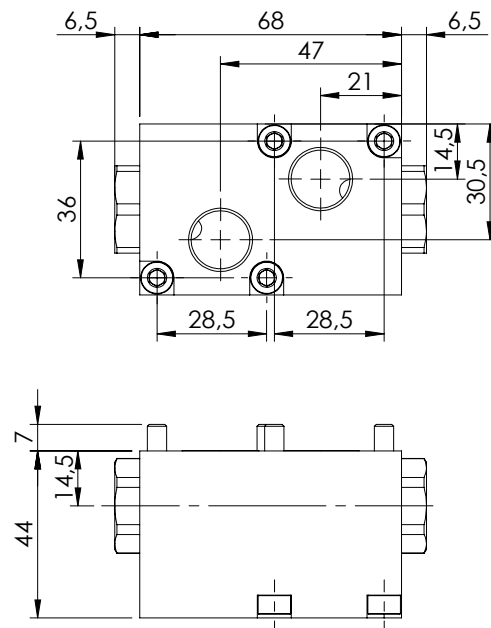

MBDN-060-ZNFD

**OVERCENTER
FLANGEABLE VALVE**

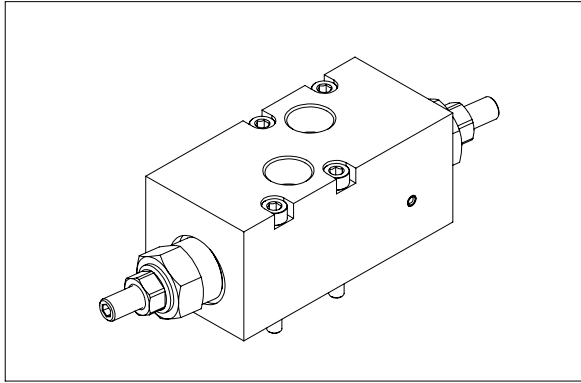

HYDRAULIC SCHEME

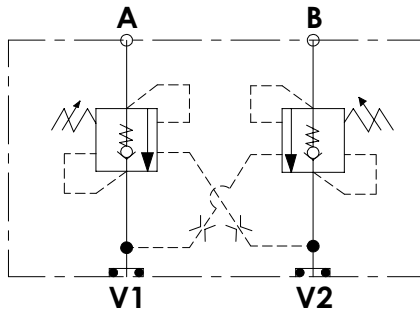

This modular block is made with overcenter valves to control the load on A and B port. The valves are poppet type with a pilot ratio of 4:1, other pilot ratios are available on request. The standard configuration provides valves on both lines, it is possible to order also valves on only one side. The manifold is made in aluminium with anodization surface treatment or on request in steel with zinc plating treatment.

TECHNICAL DATA

Max pressure	210/320 bar
Rated flow	60 l/min
Pilot ratio	4:1
Hydraulic fluid	Mineral oil DIN 51524
Fluid viscosity	10-500 mm ² /s
Fluid temperature	-25°C/75°C
Environment temperature	-25°C/60°C
Weight	0,4 Kg

PRESSURE DROP

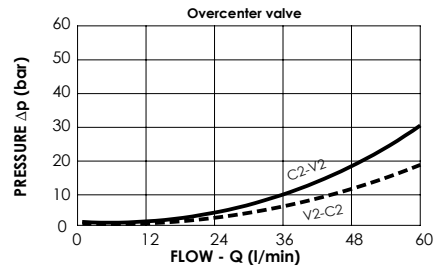

ORDERING DETAILS: SEPARATE ELEMENTS

MB - 060 - *NFD-04-***-N*****

*	VALVE TYPE
S	Single effect
D	Double effect

*	VALVE OPTION
N	Check valve on A e B ports
A	Check valve only A port
B	Check valve only B port

*	MATERIAL TYPE
A	Steel zinc-plated (320 bar)
Z	Aluminium anodized (210 bar)

***	PORTS		
	A line	B line	M
G38	G 3/8"	G 3/8"	/
U09	9/16"-18 UNF	9/16"-18 UNF	/

*	O-RING TYPE
100	100 bar settings
210	210 bar settings (standard)
320	320 bar settings (steel manifold)

QUICK CODE	
DESCRIPTION	CODE
MBDN-060-ZNFD-04-G38-N210	MB000874
MBSA-060-ZNFD-04-G38-N210	MB000875

OVERALL DIMENSIONS

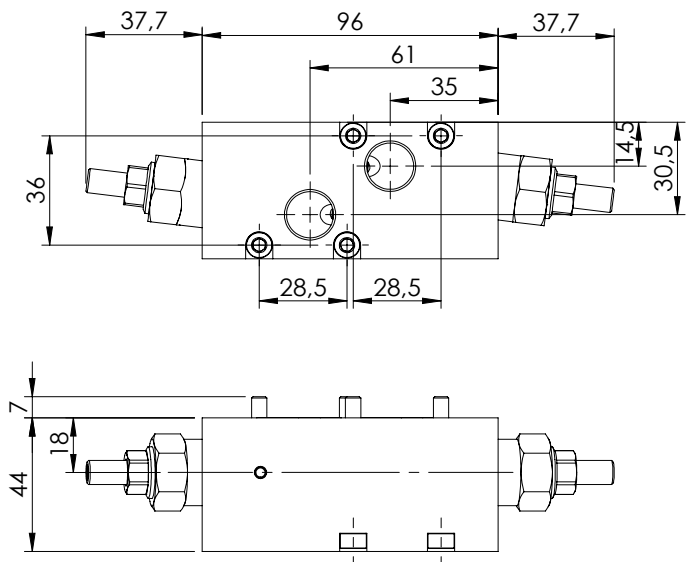

EB - MODULAR VALVE SECTION



KEDN-060-ZNFD

IN LINE ELETRICAL FLANGEABLE VALVE

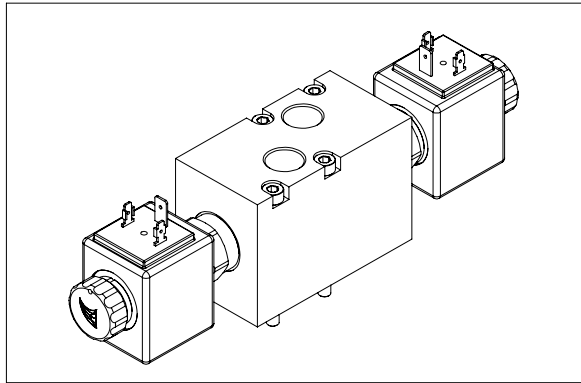

HYDRAULIC SCHEME

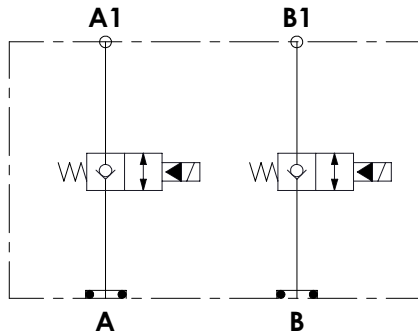

This modular block is equipped with solenoid valves, normally closed, poppet type and can be used to obtain a leak free function on the spool valve or to stop functions. It is available in three configurations, with valves on both lines or on A or on B line.

The manifold is made in aluminium with anodization surface treatment or on request in steel with zinc plating treatment.

TECHNICAL DATA

Max pressure	210/320 bar
Rated flow	60 l/min
Insertion	100% ED
Hydraulic fluid	Mineral oil DIN 51524
Fluid viscosity	10-500 mm ² /s
Fluid temperature	-25°C/75°C
Environment temperature	-25°C/60°C
Weight	0,4 Kg

PRESSURE DROP

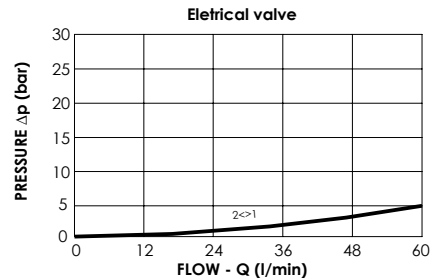

ORDERING DETAILS: SEPARATE ELEMENTS

KE * * - 060 - * NFD-04 - * * * - * * * N

* VALVE TYPE	
S	Single effect
D	Double effect

* VALVE OPTION	
N	EV on A e B ports
A	EV only A port
B	EV only B port

* MATERIAL TYPE	
A	Steel zinc-plated (320 bar)
Z	Aluminium anodized (210 bar)

***	PORTS		
	A line	B line	M
G38	G 3/8"	G 3/8"	/
U09	9/16"-18 UNF	9/16"-18 UNF	/

* VOLTAGE	
	no coils
A	12 V dc
B	24 V dc

** COILS TYPE	
	no coils
HR	Hirschmann (ISO 4400 DIN 43650)
DT	Deutsch (DT04-2P)
AJ	Amp junior (AJ type)

QUICK CODE	
DESCRIPTION	CODE

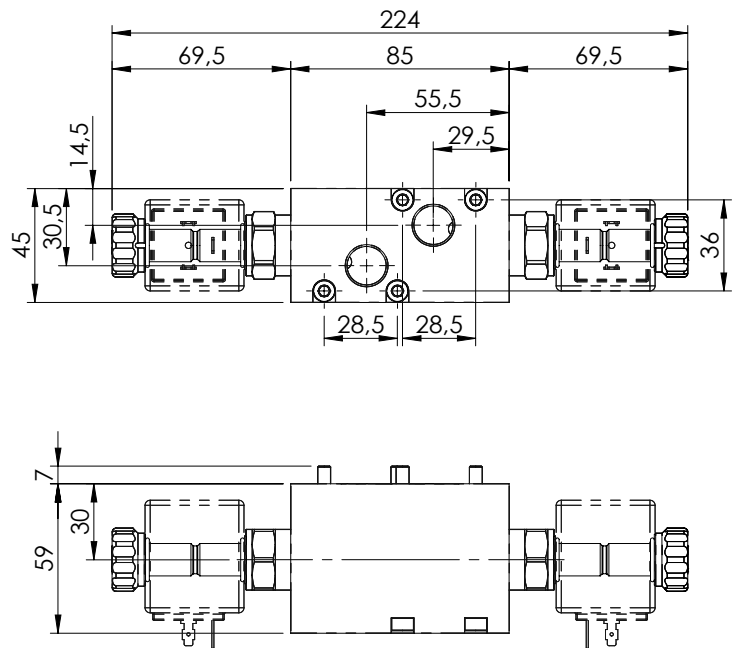

OVERALL DIMENSIONS

EB - MODULAR VALVE SECTION

KFDN-060-ZNFD

**IN LINE FLOW RESTRICTOR
FLANGIABLE VALVE**

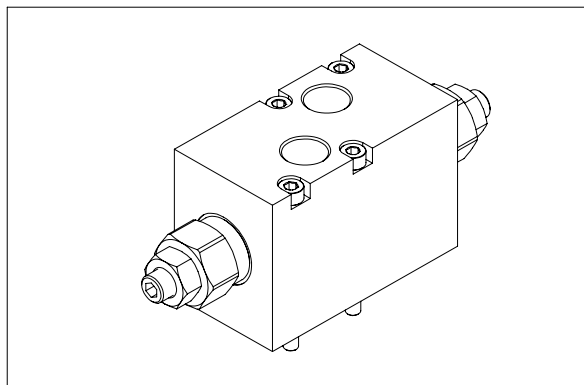

HYDRAULIC SCHEME

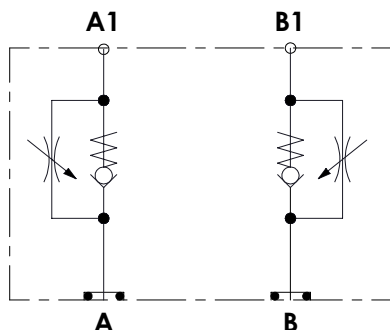

This modular valve is equipped with mono directional flow restrictor not compensated to adjust the speed of the application; it is available in three configurations, with valves on A line, on B line (single effect) or A and B line (double effect). The manifold is made in aluminium with anodization surface treatment or on request in steel with zinc plating treatment.

TECHNICAL DATA

Max pressure	210/320 bar
Rated flow	60 l/min
Hydraulic fluid	Mineral oil DIN 51524
Fluid viscosity	10-500 mm ² /s
Fluid temperature	-25°C/75°C
Environment temperature	-25°C/60°C
Weight	0,8 Kg

PRESSURE DROP

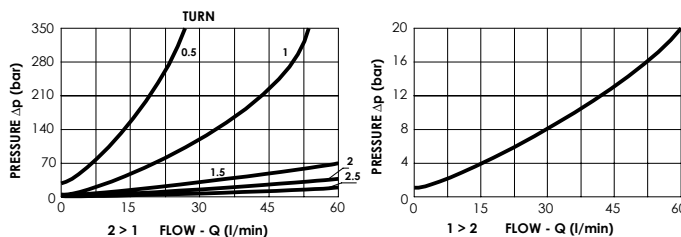

ORDERING DETAILS: SEPARATE ELEMENTS

KF * * - 060 - * NFD-04 - * * * - N

*	VALVE TYPE
S	Single effect
D	Double effect

*	VALVE OPTION
N	Flow restrictor on A e B ports
A	Flow restrictor only A port
B	Flow restrictor only B port

*	MATERIAL TYPE
A	Steel zinc-plated (320 bar)
Z	Aluminium anodized (210 bar)

***	PORTS		
	A line	B line	M
G38	G 3/8"	G 3/8"	/
U09	9/16"-18 UNF	9/16"-18 UNF	/

QUICK CODE	
DESCRIPTION	CODE

OVERALL DIMENSIONS

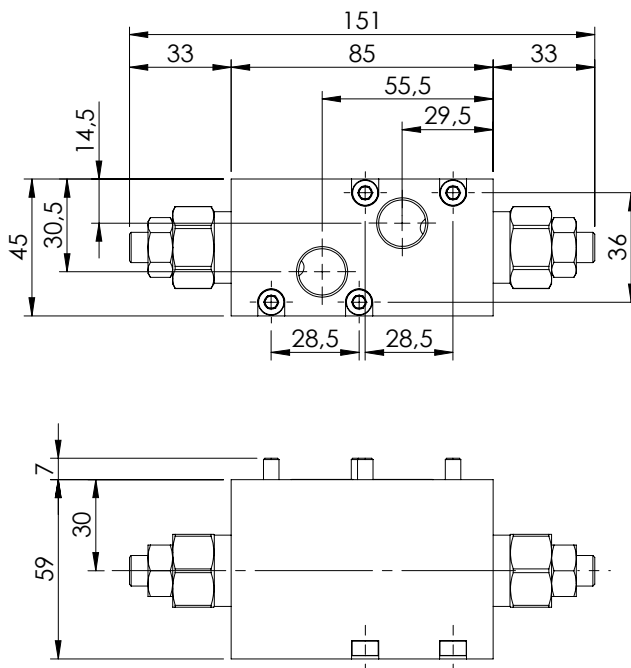

EB - COIL SECTION



COIL SERIES M7

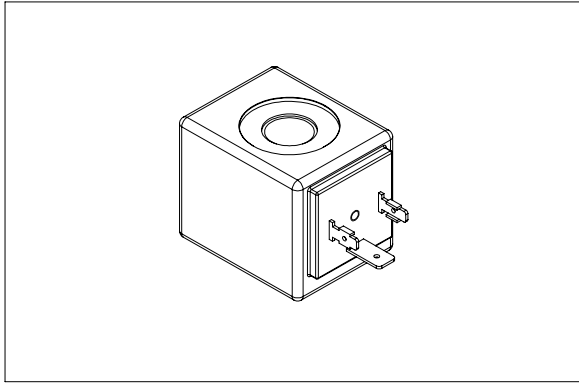

COIL TYPE

The coils have the magnetic circuit coated with black thermoplastic material. All metal parts are protected against oxidation according to RoHS directive. For proper insulation it is required to install the proper seals supplied with the tubes.

TECHNICAL DATA

Protection type	IP 65 with all seal
Protection type	IP 69K with all seal only DT
Alimentation tolerance	+10%
Ambient temperature	-20°C +50°C
Duty cycle	100% ED (max 40°C ambient)
Isolation class	Class H (max 180°C)
Weight	0,18 kg

Coils are available with three different connections type, special voltage are available on request, please contact AFT sales network.

(1) Ambient temperature 25°C

(2) Ambient temperature 20°C

OVERALL DIMENSIONS

DIN 43650 (HR)

Coils		Max winding temperature (1)	Nominal potency	Resistance (±7%) (2)	Code parts
Code	Voltage				
A	12 V DC	135°C	20 W	7.2	AB000002
B	24 V DC	135°C	20 W	28.8	AB000003
C	48 V DC	135°C	20 W	115.2	AB000046
D	110 R AC	120°C	20 W	605	AB000012
E	220 R AC	120°C	20 W	2420	AB000007

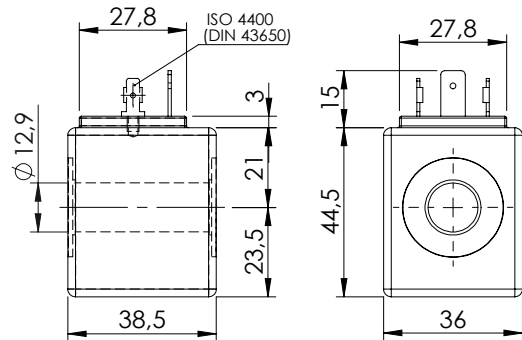

DEUTSCH (DTV)

Coils		Max winding temperature (1)	Nominal potency	Resistance (±7%) (2)	Code parts
Code	Voltage				
A	12 V DC	135°C	20 W	7.2	AB000022
B	24 V DC	135°C	20 W	28.8	AB000023
C	48 V DC	135°C	20 W	115.2	
D	110 R AC	120°C	20 W	605	
E	220 R AC	120°C	20 W	2420	

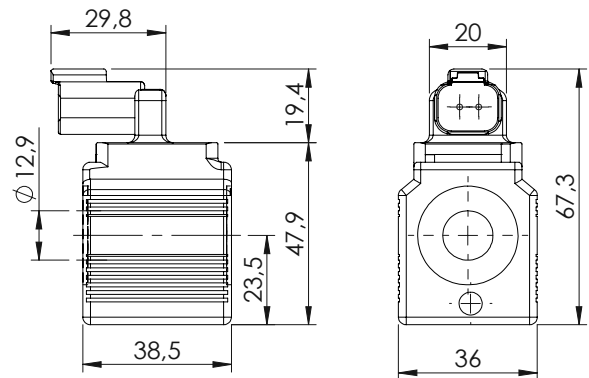

AMP JUNIOR (AJ)

Coils		Max winding temperature	Nominal potency	Resistance (±7%)	Code parts
Code	Voltage				
A	12 V DC	135°C	20 W	7.2	AB000005
B	24 V DC	135°C	20 W	28.8	AB000014
C	48 V DC	135°C	20 W	115.2	AB000021
D	110 R AC	120°C	20 W	605	
E	220 R AC	120°C	20 W	2420	

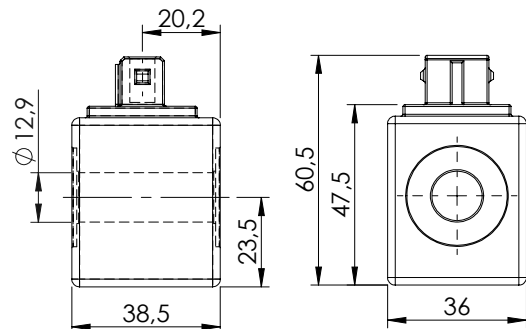

COIL SERIES M14

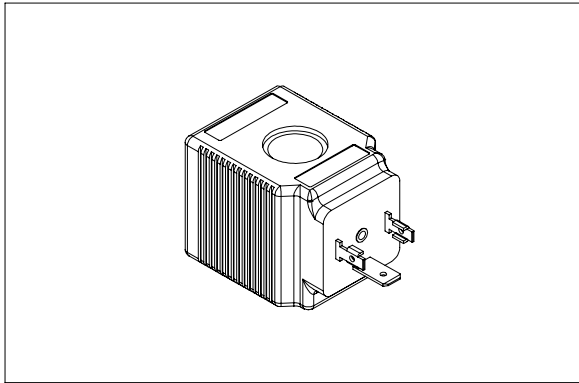

COILS TYPE

The coils have the magnetic circuit coated with black thermoplastic material. All metal parts are protected against oxidation according to RoHS directive. For proper insulation it is required to install the proper seals supplied with the tubes.

TECHNICAL DATA

Protection type	IP 65 with all seal
Protection type	IP 69K with all seal only DT
Activation	18000/h
Alimentation tolerance	+10%
Ambient temperature	-20°C + 50°C
Duty cycle	100% ED (max 40°C ambient)
Isolation class	Class H (max 180°C)
Weight	0,18 kg

OVERALL DIMENSIONS

Coils are available with three different connections type, special voltage are available on request, please contact AFT sales network.

- (1) Ambient temperature 25°C
- (2) Ambient temperature 20°C

DIN 43650 (HR)

Coils		Max winding temperature (1)	Nominal potency	Resistance (±7%) (2)	Code parts
Code	Voltage				
A	12 V DC	135°C	26 W	5.54	AB000143
B	24 V DC	135°C	26 W	22.15	AB000144
C	48 V DC	135°C	26 W	88.6	
D	110 R AC	120°C	26 W	465.4	
E	220 R AC	120°C	26 W	1861.5	

DEUTSCH (DTV)

Coils		Max winding temperature (1)	Nominal potency	Resistance (±7%) (2)	Code parts
Code	Voltage				
A	12 V DC	135°C	26 W	5.54	AB000132
B	24 V DC	135°C	26 W	22.15	AB000133
C	48 V DC	135°C	26 W	88.6	
D	110 R AC	120°C	26 W	465.4	
E	220 R AC	120°C	26 W	1861.5	

AMP JUNIOR (AJ)

Coils		Max winding temperature	Nominal potency	Resistance (±7%)	Code parts
Code	Voltage				
A	12 V DC	135°C	26 W	5.54	AB000136
B	24 V DC	135°C	26 W	22.15	
C	48 V DC	135°C	26 W	88.6	AB000131
D	110 R AC	120°C	26 W	465.4	
E	220 R AC	120°C	26 W	1861.5	

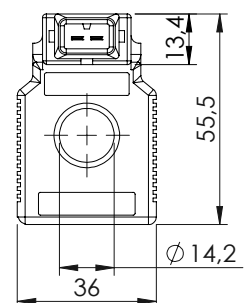
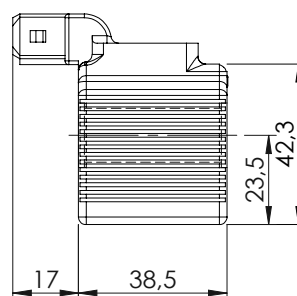
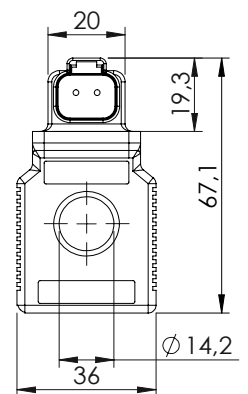
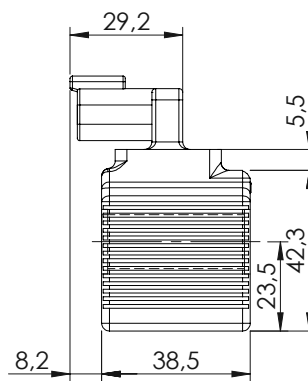
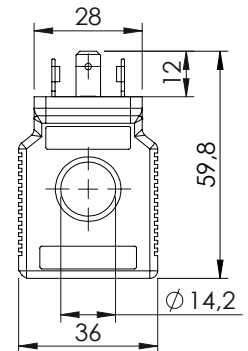
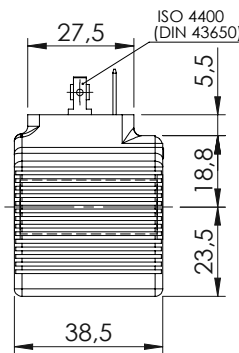

COIL SERIES M8

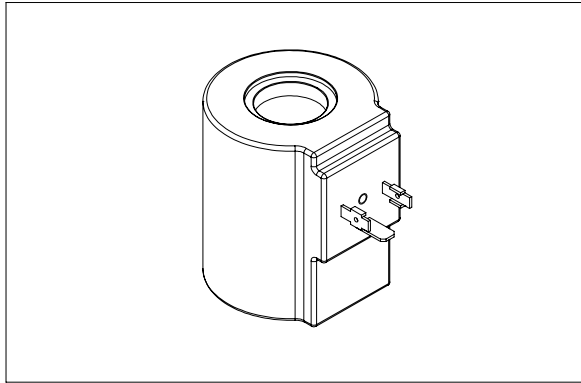

COILS TYPE

The coils have the magnetic circuit coated with black thermoplastic material. All metal parts are protected against oxidation according to RoHS directive. For proper insulation it is required to install the proper seals supplied with the tubes.

TECHNICAL DATA

Protection type	IP 65 with all seal
Protection type	IP 69K with all seal only DT
Alimentation tolerance	+10%
Ambient temperature	-20°C + 50°C
Duty cycle	100% ED (max 40°C ambient)
Isolation class	Class H (max 180°C)
Weight	0,18 kg

Coils are available with three different connections type, special voltage are available on request, please contact AFT sales network.

- (1) Ambient temperature 25°C
- (2) Ambient temperature 20°C

OVERALL DIMENSIONS

HIRSCHMANN (HR)

Coils		Max winding temperature (1)	Nominal potency	Resistance (±7%) (2)	Code parts
Code	Voltage				
A	12 V DC	135°C	33 W	4.36	AB000015
B	24 V DC	135°C	33 W	17.5	AB000029
C	48 V DC	135°C	33 W	69.8	AB000158
D	110 R AC	120°C	33 W	366.7	AB000092
E	220 R AC	120°C	33 W	1466.7	

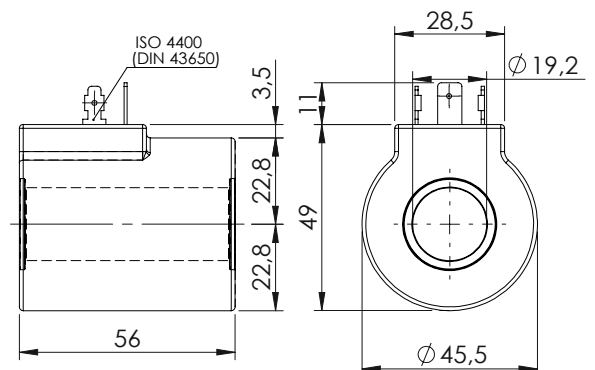

DEUTSCH (DTV)

Coils		Max winding temperature (1)	Nominal potency	Resistance (±7%) (2)	Code parts
Code	Voltage				
A	12 V DC	135°C	33 W	4.36	AB000104
B	24 V DC	135°C	33 W	17.5	AB000105
C	48 V DC	135°C	33 W	69.8	
D	110 R AC	120°C	33 W	366.7	
E	220 R AC	120°C	33 W	1466.7	

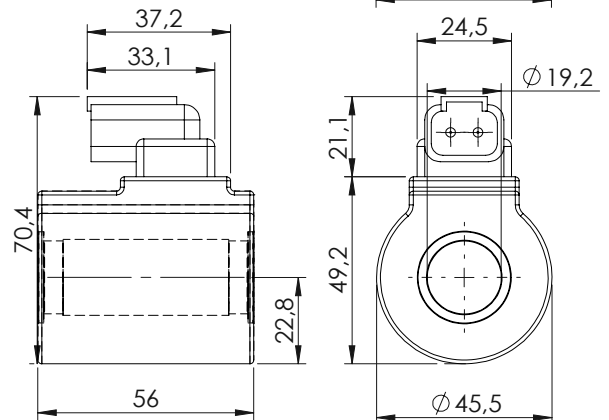

AMP JUNIOR (AJ)

Coils		Max winding temperature	Nominal potency	Resistance (±7%)	Code parts
Code	Voltage				
A	12 V DC	135°C	33 W	4.36	AB000048
B	24 V DC	135°C	33 W	17.5	
C	48 V DC	135°C	33 W	69.8	
D	110 R AC	120°C	33 W	366.7	
E	220 R AC	120°C	33 W	1466.7	

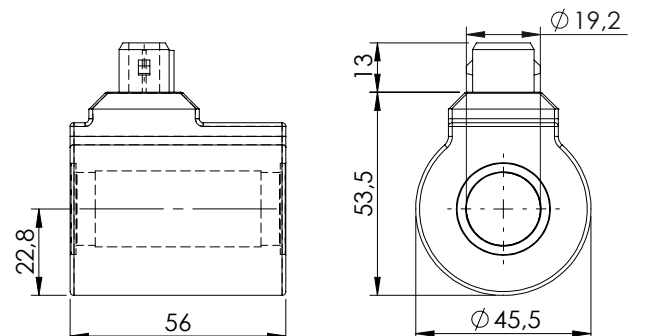

COIL SERIES M15

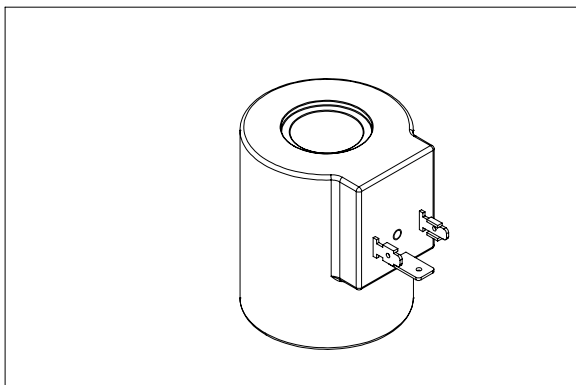

COILS TYPE

The coils have the magnetic circuit coated with black thermoplastic material. All metal parts are protected against oxidation according to RoHS directive. For proper insulation it is required to install the proper seals supplied with the tubes.

TECHNICAL DATA

Protection type	IP 65 with all seal
Protection type	IP 69K with all seal only DT
Alimentation tolerance	+10%
Ambient temperature	-20°C + 50°C
Duty cycle	100% ED (max 40°C ambient)
Isolation class	Class H (max 180°C)
Weight	0,18 kg

Coils are available with three different connections type, special voltage are available on request, please contact AFT sales network.

- (1) Ambient temperature 25°C
- (2) Ambient temperature 20°C

OVERALL DIMENSIONS

HIRSCHMANN (HR)

Coils		Max winding temperature (1)	Nominal potency	Resistance (±7%) (2)	Code parts
Code	Voltage				
A	12 V DC	135°C	23 W	6.3	AB000137
B	24 V DC	135°C	23 W	25	AB000138
C	48 V DC	135°C	23 W	100.2	
D	110 R AC	120°C	23 W	526	
E	220 R AC	120°C	23 W	2104.3	

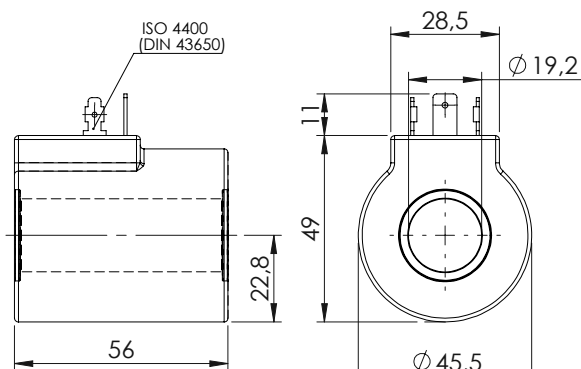

DEUTSCH (DTV)

Coils		Max winding temperature (1)	Nominal potency	Resistance (±7%) (2)	Code parts
Code	Voltage				
A	12 V DC	135°C	23 W	6.3	AB000141
B	24 V DC	135°C	23 W	25	AB000142
C	48 V DC	135°C	23 W	100.2	
D	110 R AC	120°C	23 W	526	
E	220 R AC	120°C	23 W	2104.3	

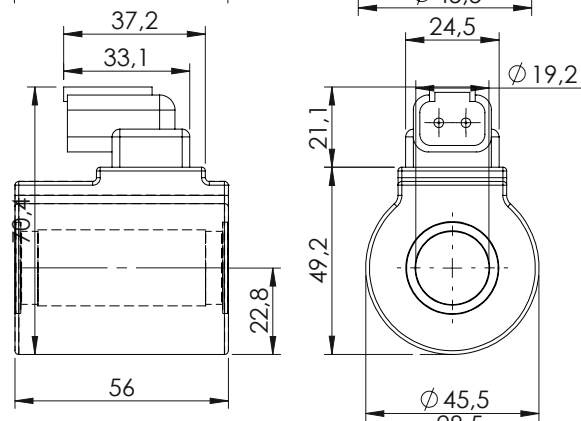

AMP JUNIOR (AJ)

Coils		Max winding temperature	Nominal potency	Resistance (±7%)	Code parts
Code	Voltage				
A	12 V DC	135°C	23 W	6.3	AB000139
B	24 V DC	135°C	23 W	25	AB000140
C	48 V DC	135°C	23 W	100.2	
D	110 R AC	120°C	23 W	526	
E	220 R AC	120°C	23 W	2104.3	

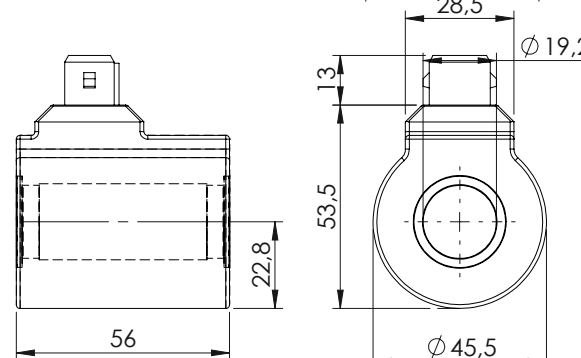

CONNECTORS

CONNECTOR FOR SOLENOID VALVE

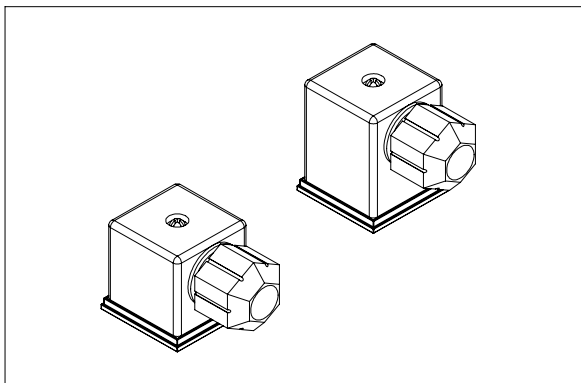

Connector for solenoid valve according to standards DIN 43650 / ISO 4400, different types of circuits are available, standard circuit, circuit with "VDR", circuit with "VDR+ rectifier" or circuit with LED

ELECTRIC SCHEME

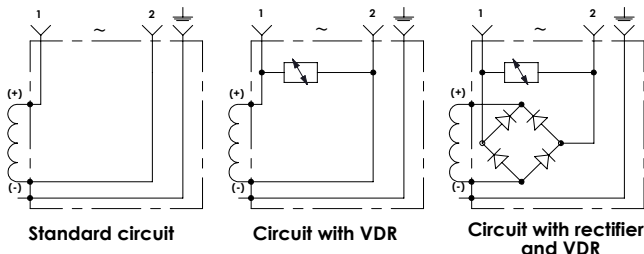

TECHNICAL DATA

Voltage rating	AC/DC: up to 250/300 V max
Max current	16.0 A
Contact resistance	≤ 4 mΩ
Max conductor	1.5 mm ²
Cable range	Ø4.0 to Ø9.0 mm
Protection class	IP 67 EN60529
Seal	Nitrile rubber
Poles	2 plus ground
Connector	EN 175301-803 (DIN 43650)

OVERALL DIMENSIONS

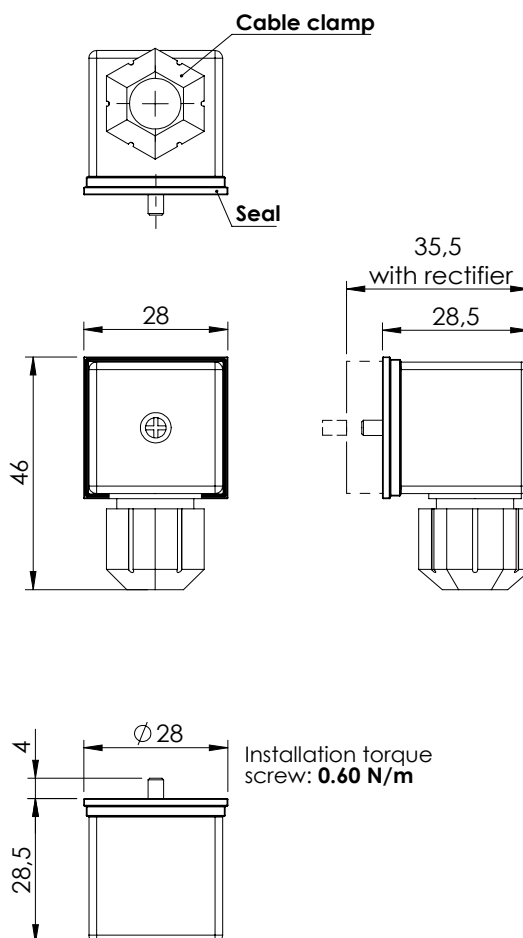

ORDERING DETAILS: SEPARATE ELEMENTS

Quick code	Colour	VDR	LED	Rectifier	Voltage
PV000171	Black	No	No	No	12V to 230V
PV000195	Black	Yes	No	No	12V dc
PV000349	Black	Yes	No	No	24V dc
PV000198	Trasparent	Yes	Yes	No	12V dc
PV000196	Trasparent	Yes	Yes	No	24V dc
PV000347	Black	Yes	No	Yes	12V RAC
PV000348	Black	Yes	No	Yes	24V RAC
	Black	Yes	No	Yes	110V RAC
	Black	Yes	No	Yes	220V RAC
	Trasparent	Yes	Yes	Yes	110V RAC
	Trasparent	Yes	Yes	Yes	220V RAC

NB: To have full performance and to guarantee the IP 65 level of protection, it is essential to assemble connectors with the supplied seals and with screw properly installed.

EB - ORDERING PART SECTION

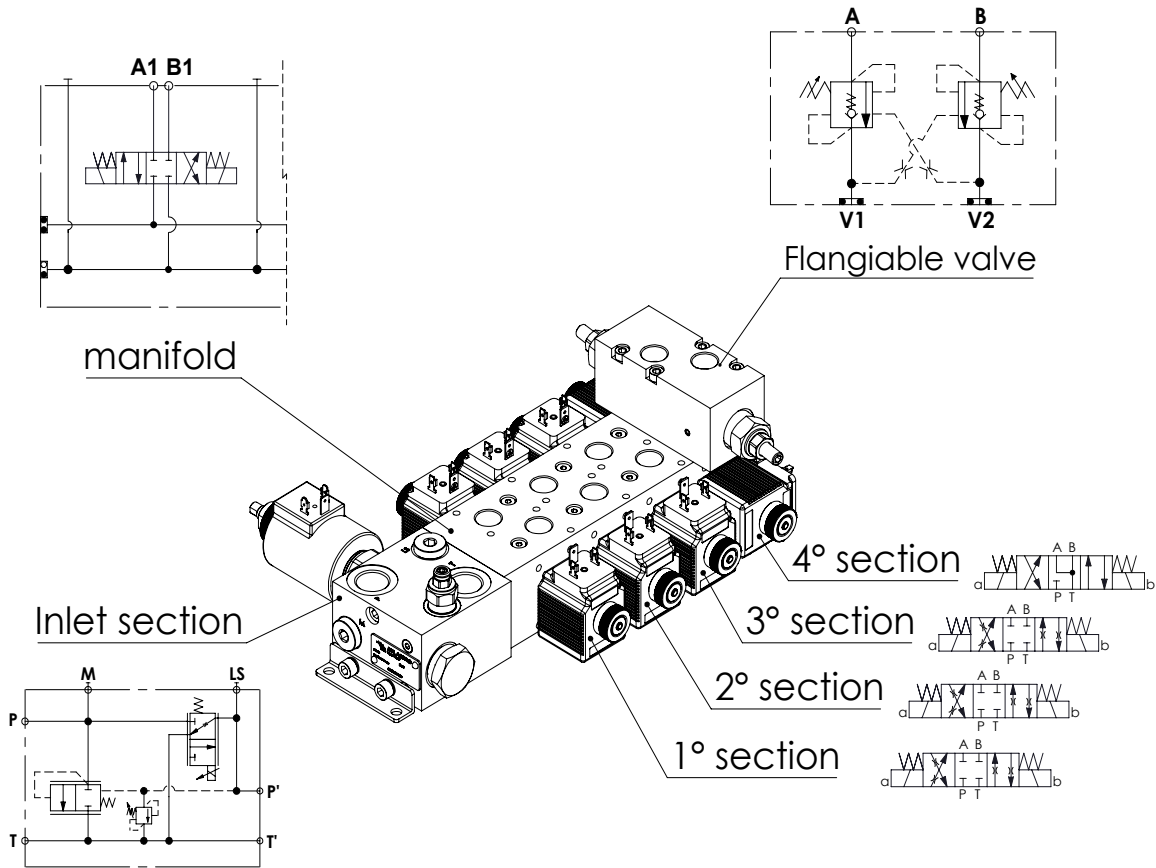

ORDER CODE

	QUICK CODE OR DESCRIPTION	COIL QUICK CODE OR DESCRIPTION
INLET SECTION		
MANIFOLD		
SPOOL SECTION 1		
FLANGEABLE VALVE SECTION 1		
SPOOL SECTION 2		
FLANGEABLE VALVE SECTION 2		
SPOOL SECTION 3		
FLANGEABLE VALVE SECTION 3		
SPOOL SECTION 4		
FLANGEABLE VALVE SECTION 4		
SPOOL SECTION 5		
FLANGEABLE VALVE SECTION 5		
SPOOL SECTION 6		
FLANGEABLE VALVE SECTION 6		
SPOOL SECTION 7		
FLANGEABLE VALVE SECTION 7		
SPOOL SECTION 8		
FLANGEABLE VALVE SECTION 8		
COILS		
OPTIONS		
OPTIONS		



ATLANTIC
Fluid Tech

SECTION 2

Pressure
Reducing
Valves



1800-OILSOL
1800-645765

<https://oilsolutions.com.au/>

sales@oilsolutions.com.au

SECTION 2



PRESSURE REDUCING VALVES

Hydraulic scheme	Valve description	Valve type	Rated flow (l/min)	Max. pressure (bar)	Installation	Main port size or cavity type	Page
	CPRL-007-DNNR	Direct acting, reducing and relieving	5	350	Cartridge	VP000016	2.01.010
	CPRL-030-DNNR	Direct acting, reducing and relieving	30	350	Cartridge	SAE-10-3N	2.01.020
	CPRL-030-DNSR	Direct acting, reducing and relieving	30	350	Cartridge	SAE-10-3N	2.01.030
	CPRL-030-DNSR-LN	Direct acting, reducing and relieving, panel installation	30	350	Cartridge	SAE-10-3N	2.01.040
	KPRL-030-DNSR	Direct acting, reducing and relieving, with check valve	30	210	In line	G3/8"	2.01.050
	KPRL-030-DNNR	Direct acting, reducing and relieving	30	250	In line	G3/8"	2.02.080
	CPRL-060-PNNR	Pilot operated, reducing and relieving	60	350	Cartridge	SAE-10-3N	2.02.060
	CPRL-140-PNNR	Pilot operated, reducing and relieving	140	350	Cartridge	SAE-12-3N	2.02.070
	KPRL-060-DNNR	Pilot operated, reducing and relieving	60	250	In line	G3/8"	2.02.080
	CPRR-060-PNNR	Pilot operated, reducing	60	350	Cartridge	SAE-10-3N	2.03.090
	CPRR-140-PNNR	Pilot operated, reducing	140	350	Cartridge	SAE-12-3N	2.03.100
	KPRR-140-PNNR	Pilot operated, reducing	140	350	In line	G1/2"	2.03.110

PRESSURE REDUCING AND RELIEVING

CPRL-007-DNNR

**DIRECT ACTING
SPOOL TYPE**

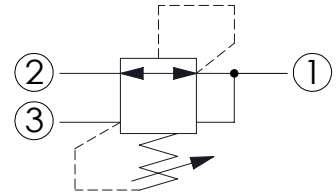
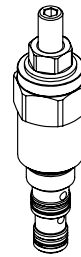
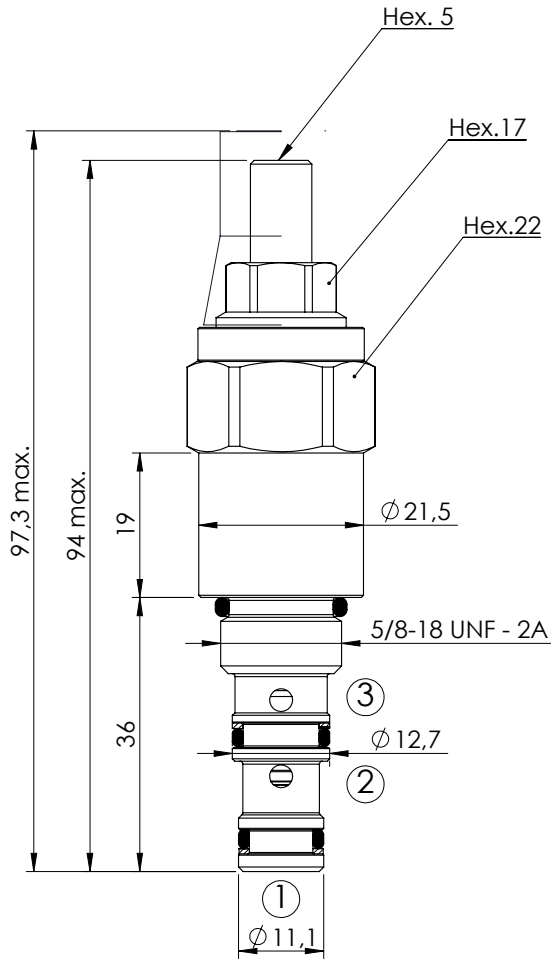

SPECIFICATIONS

Max. operating pressure:	350 bar
Rated flow:	5 l/min
Cavity:	VP000016
Weight:	0,14 kg
Installation torque:	25 - 30 Nm
Leakage:	35 cm ³ @ 50 bar
Seal kit:	RC700016

SEALING CAP

Ordering code:
AT000020

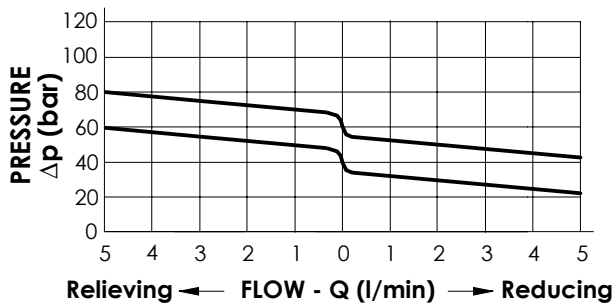

ORDERING CODES

Quick code	Description	Standard setting (bar)	Adjust. range (bar)	Pressure increase (bar/turn)	
CR000001	CPRL-007-DNNR-HN-016-N060	40	10-60	6	
CR000025	CPRL-007-DNNR-HN-016-N085	60	25-85	9	

PRESSURE REDUCING AND RELIEVING

CPRL-030-DNNR

**DIRECT ACTING
SPOOL TYPE**

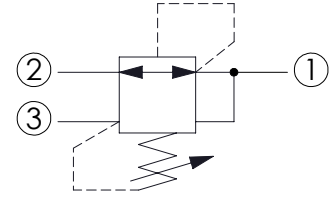
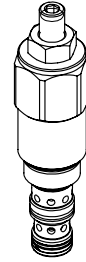
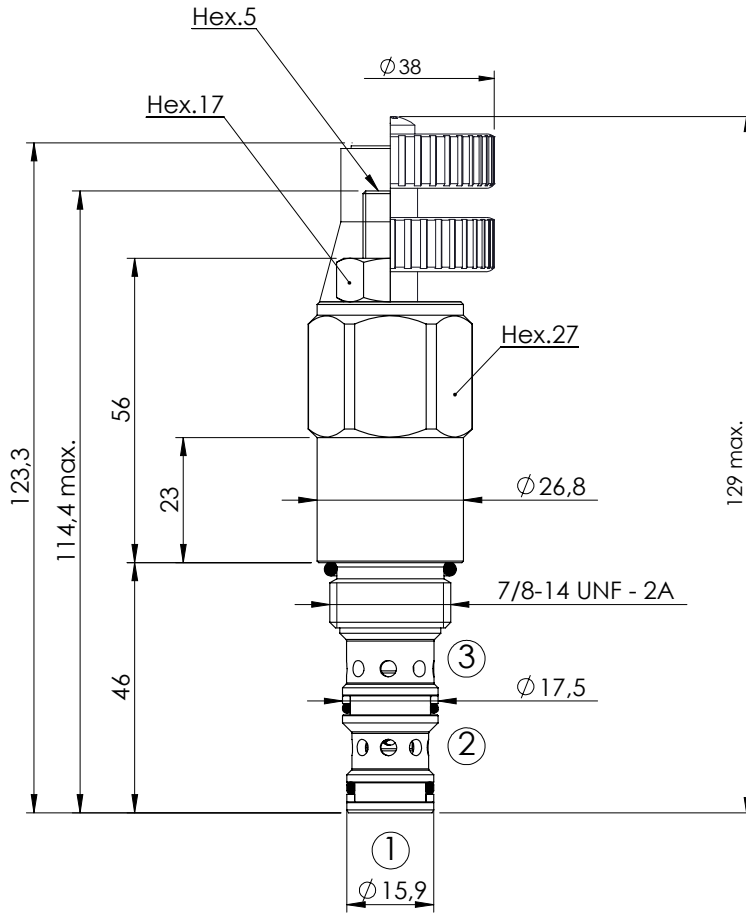

SPECIFICATIONS

Max. operating pressure:	350 bar
Rated flow:	30 l/min
Cavity:	SAE-10-3N
Weight:	0,28 kg
Installation torque:	55 - 62 Nm
Leakage:	50 cm ³ @ 50 bar
Seal kit:	RA700092

SEALING CAP

Ordering code:
AT000022

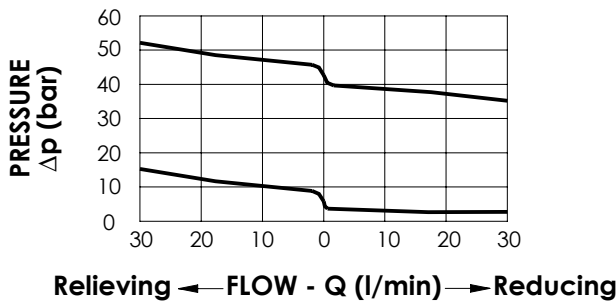

OPTIONS

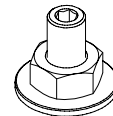

Adjustment
with Screw

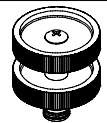

Adjustment
with Handknob

ORDERING CODES

Quick code	Description	Standard setting (bar)	Adjust. range (bar)	Pressure increase (bar/turn)	Options
CR000002	CPRL-030-DNNR-HN-S10-N050	35	10-50	7	Adjustment with Screw
CR000008	CPRL-030-DNNR-VN-S10-N050	35	10-50	7	Adjustment with Handknob
CR000011	CPRL-030-DNNR-HN-S10-N015	5	1.5-15	1	Adjustment with Screw
CR000012	CPRL-030-DNNR-VN-S10-N015	5	1.5-15	1	Adjustment with Handknob

PRESSURE REDUCING AND RELIEVING

CPRL-030-DNSR

**DIRECT ACTING
SPOOL TYPE
WITH DAMPING**

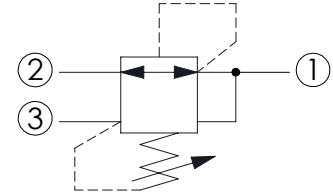
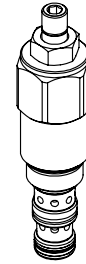
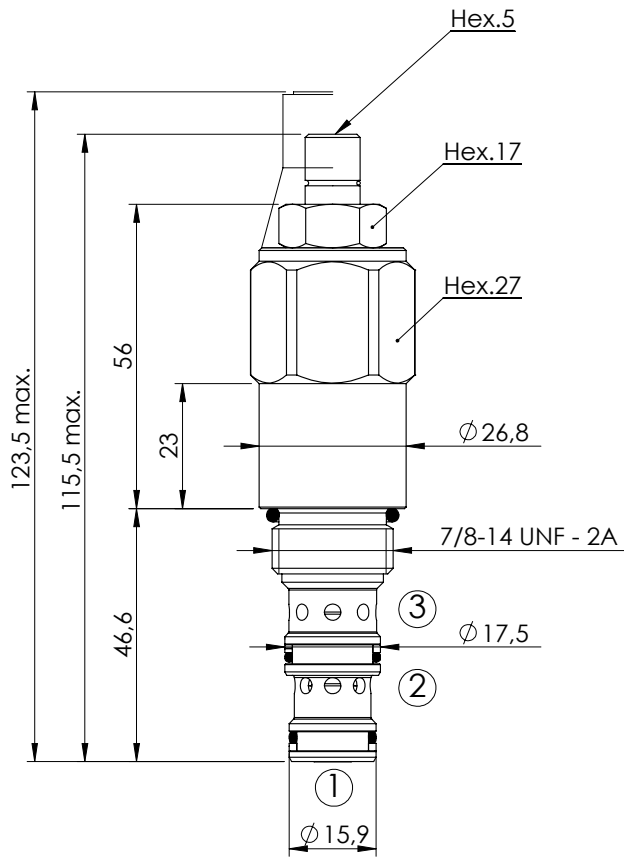

SPECIFICATIONS

Max. operating pressure:	350 bar
Rated flow:	30 l/min
Cavity:	SAE-10-3N
Weight:	0,29 kg
Installation torque:	55 - 62 Nm
Leakage:	50 cm ³ @ 50 bar
Seal kit:	RA700092

SEALING CAP

Ordering code:

AT000021



OPTIONS

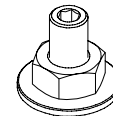

**Adjustment
with Screw**

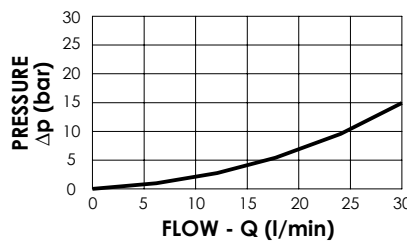
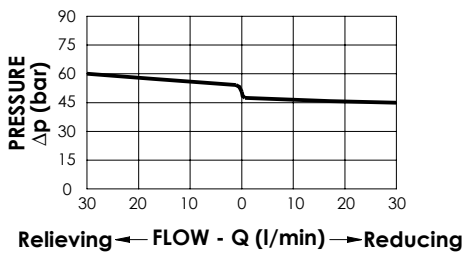

ORDERING CODES

Quick code	Description	Standard setting (bar)	Adjust. range (bar)	Pressure increase (bar/turn)	Options
CR000038	CPRL-030-DNSR-HN-S10-N080	50	20-75	11	Adjustment with Screw
CR000056	CPRL-030-DNSR-HN-S10-N040	20	10-35	5,3	Adjustment with Screw

PRESSURE REDUCING AND RELIEVING

CPRL-030-DNSR

**DIRECT ACTING
SPOOL TYPE
PANEL INSTALLATION**

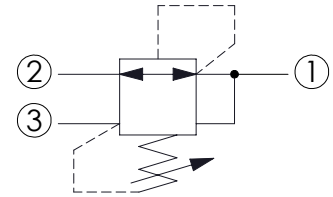
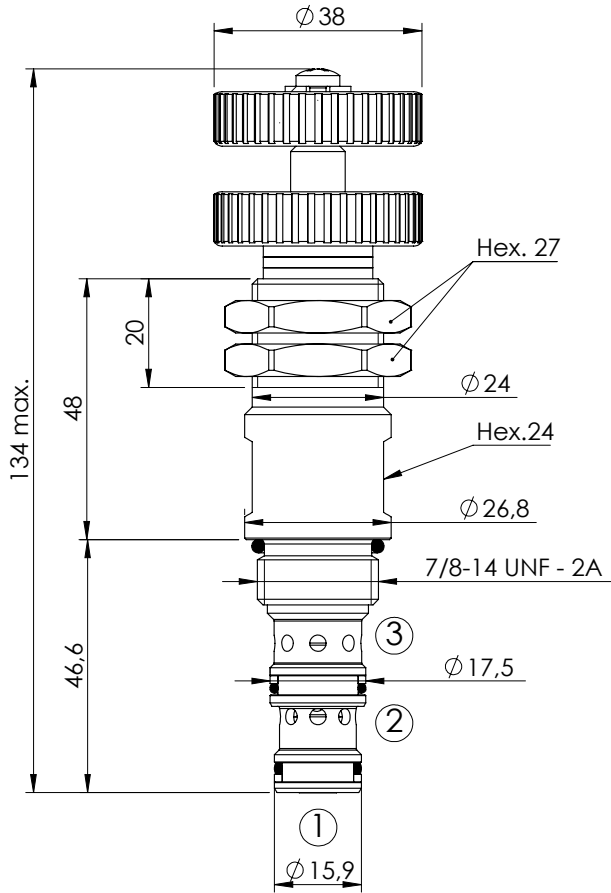

SPECIFICATIONS

Max. operating pressure:	350 bar
Rated flow:	30 l/min
Cavity:	SAE-10-3N
Weight:	0,31 kg
Installation torque:	55 - 62 Nm
Leakage:	50 cm ³ @ 50 bar
Seal kit:	RA700092

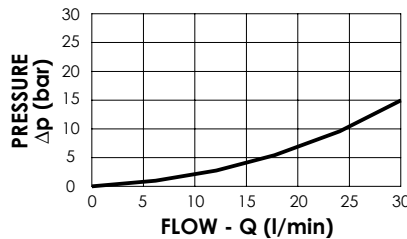
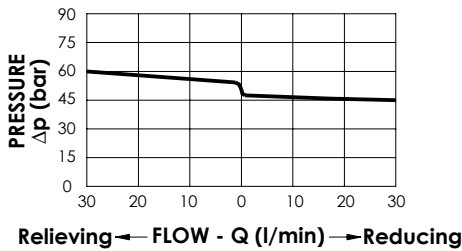

OPTIONS



Adjustment with Handknob

ORDERING CODES

Quick code	Description	Standard setting (bar)	Adjust. range (bar)	Pressure increase (bar/turn)	Options
CR000048	CPRL-030-DNSR-LN-S10-N045	20	10 - 45	5,3	Adjustment with Handknob

PRESSURE REDUCING AND RELIEVING IN BODY

KPRL-030-DNSR

**DIRECT ACTING
WITH CHECK VALVE**

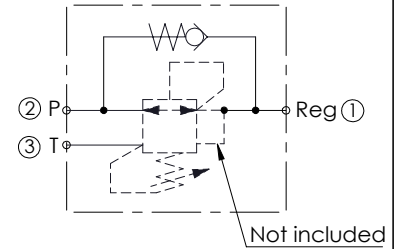
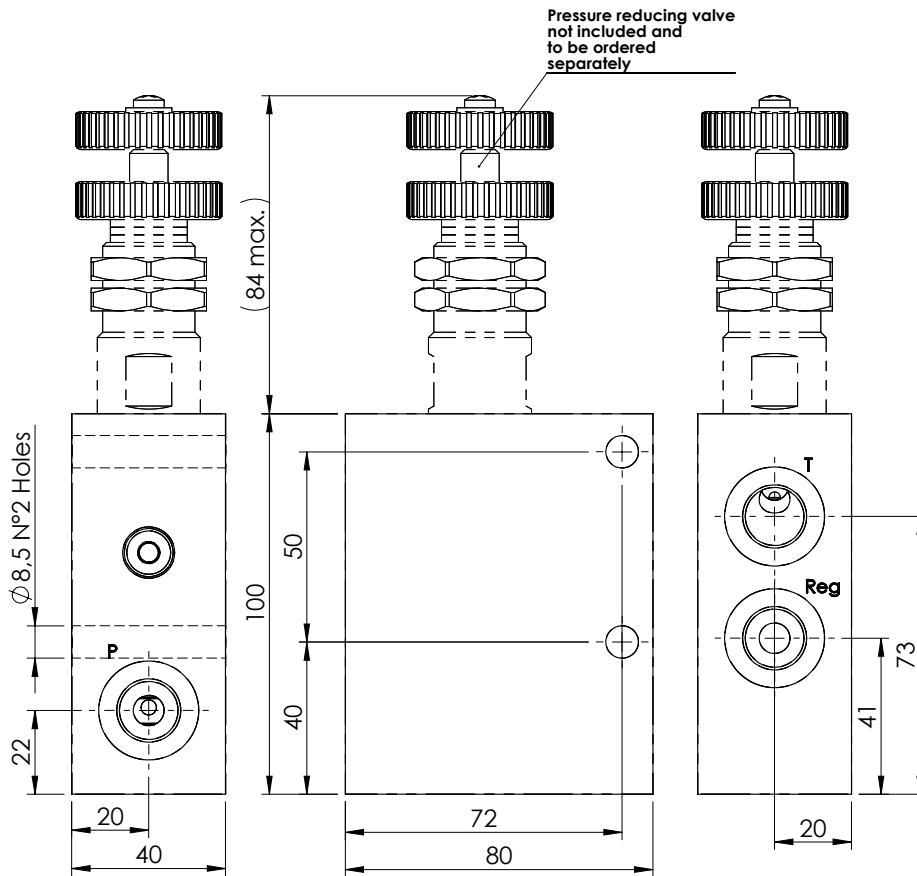
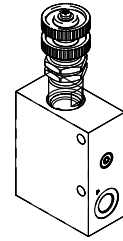

SPECIFICATIONS

Max. operating pressure:	210 bar
Rated flow:	30 l/min
Cavity type:	SAE-10-3N
Weight:	0,87 Kg
Manifold:	Aluminium

NOTES

-See pages 2.01.030 or 2.01.040 for pressure reducing valve info.

ORDERING CODES

Quick code	Description	Ports	
KR000043	KPRL-030-DNSR-HN-G38-N210	G 3/8"	

PRESSURE REDUCING AND RELIEVING

CPRL-060-PNNR

**PILOT OPERATED
SPOOL TYPE**

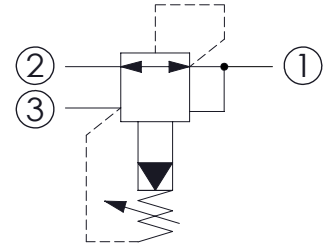
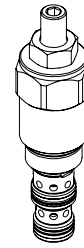
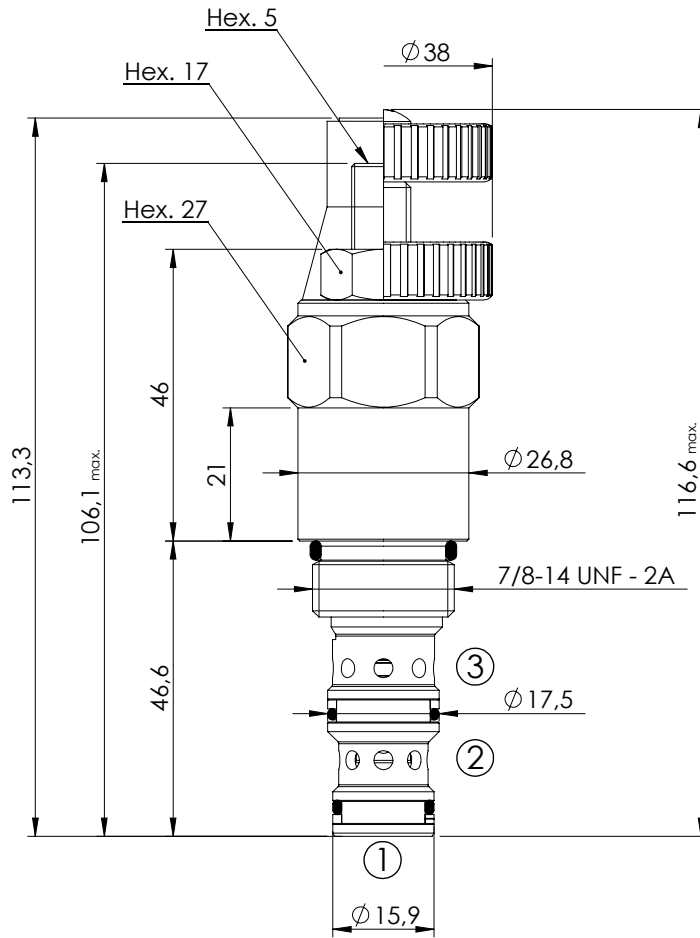

SPECIFICATIONS

Max. operating pressure:	350 bar
Rated flow:	60 l/min
Cavity:	SAE-10-3N
Weight:	0,26 kg
Installation torque:	55 - 62 Nm
Seal kit:	RA700092

SEALING CAP

Ordering code:
AT000022



OPTIONS

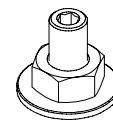

Adjustment
with Screw

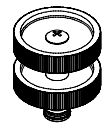

Adjustment
with Handknob

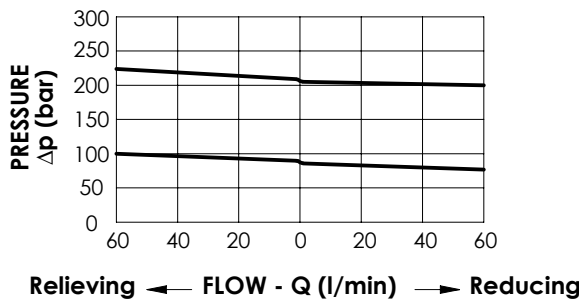

ORDERING CODES

Quick code	Description	Standard setting (bar)	Adjust. range (bar)	Pressure increase (bar/turn)	Options
CR000006	CPRL-060-PNNR-HN-S10-N300	200	70-350	114	Adjustment with Screw
CR000007	CPRL-060-PNNR-VN-S10-N300	200	70-350	114	Adjustment with Handknob
CR000009	CPRL-060-PNNR-HN-S10-N100	80	20-110	37	Adjustment with Screw
CR000010	CPRL-060-PNNR-VN-S10-N100	80	20-110	37	Adjustment with Handknob

PRESSURE REDUCING AND RELIEVING

CPRL-140-PNNR

**PILOT OPERATED
SPOOL TYPE**

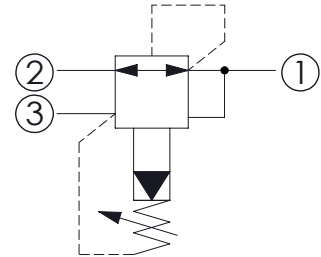
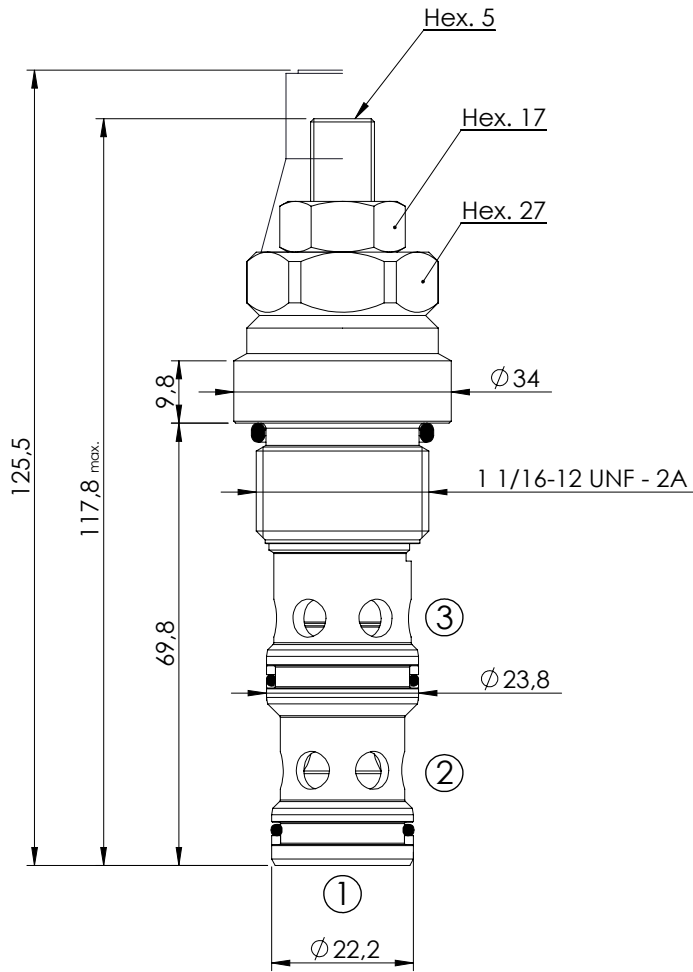

SPECIFICATIONS

Max. operating pressure:	350 bar
Rated flow:	140 l/min
Cavity:	SAE-12-3N
Weight:	0,34 kg
Installation torque:	80 - 95 Nm
Seal kit:	RA700093

SEALING CAP

Ordering code:
AT000022



OPTIONS

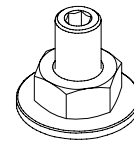

**Adjustment
with Screw**

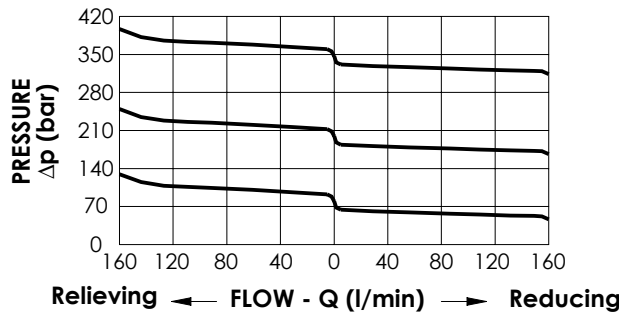

ORDERING CODES

Quick code	Description	Standard setting (bar)	Adjust. range (bar)	Pressure increase (bar/turn)	Options
CR000020	CPRL-140-PNNR-HN-S12-N350	300	140-350	114	Adjustment with Screw
CR000019	CPRL-140-PNNR-HN-S12-N200	200	70-250	69	Adjustment with Screw
CR000018	CPRL-140-PNNR-HN-S12-N100	100	10-140	37	Adjustment with Screw

PRESSURE REDUCING AND RELIEVING IN BODY

KPRL-030-DNNR

**DIRECT/PILOT ACTING
SPOOL TYPE**

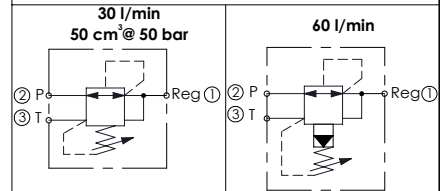
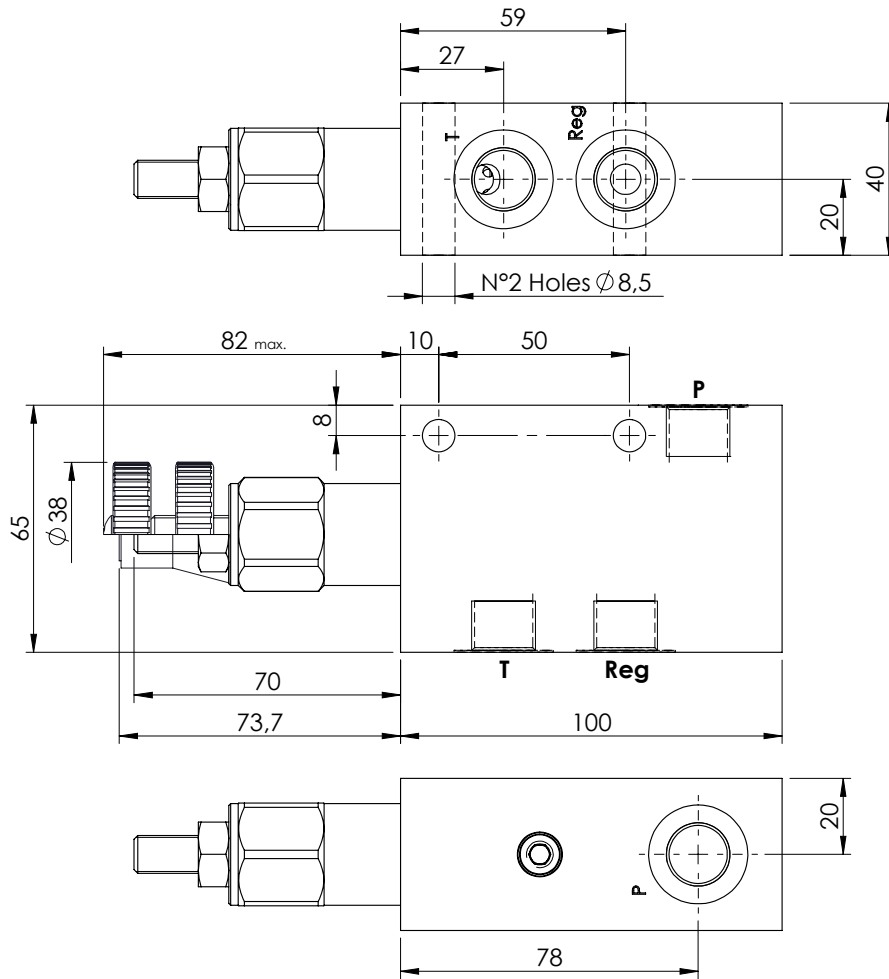
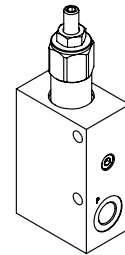

KR000011
KR000012
KR000013
KR000014

KR000015
KR000016

SPECIFICATIONS

Max. operating pressure:	250 bar
Rated flow:	30 l/min - 60 l/min
Cavity:	SAE-10-3N
Weight:	0,87 Kg
Leakage direct:	50cm ³ @ 50 bar
Manifold:	Aluminium

SEALING CAP

Ordering code:
AT000022



OPTIONS

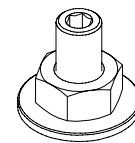

Adjustment
with Screw

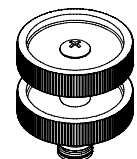

Adjustment
with Handknob

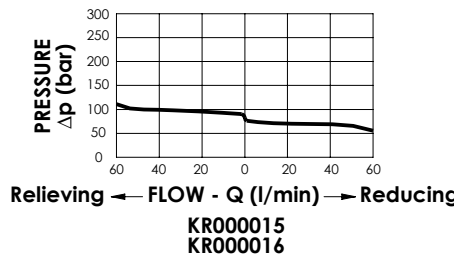
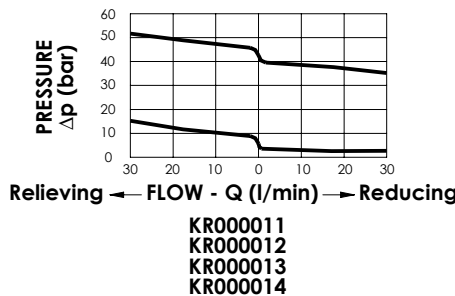

ORDERING CODES

Quick code	Description	Ports	Standard setting (bar)	Adjust. range (bar)	Pressure increase (bar/turn)	Options
KR000011	KPRL-030-DNNR-HN-G38-N250	G 3/8"	5	1.5-15	1.6	Adjustment with Screw
KR000012	KPRL-030-DNNR-VN-G38-N250	G 3/8"	5	1.5-15	1.6	Adjustment with Handknob
KR000013	KPRL-030-DNNR-HN-G38-N250	G 3/8"	35	10-50	7	Adjustment with Screw
KR000014	KPRL-030-DNNR-VN-G38-N250	G 3/8"	35	10-50	7	Adjustment with Handknob
KR000015	KPRL-060-PNNR-HN-G38-N250	G 3/8"	80	20-110	37	Adjustment with Screw
KR000016	KPRL-060-PNNR-VN-G38-N250	G 3/8"	80	20-110	37	Adjustment with Handknob

PRESSURE REDUCING

CPRR-060-PNNR

**PILOT OPERATED
SPOOL TYPE**

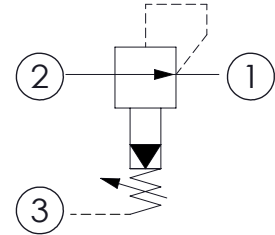
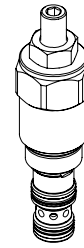
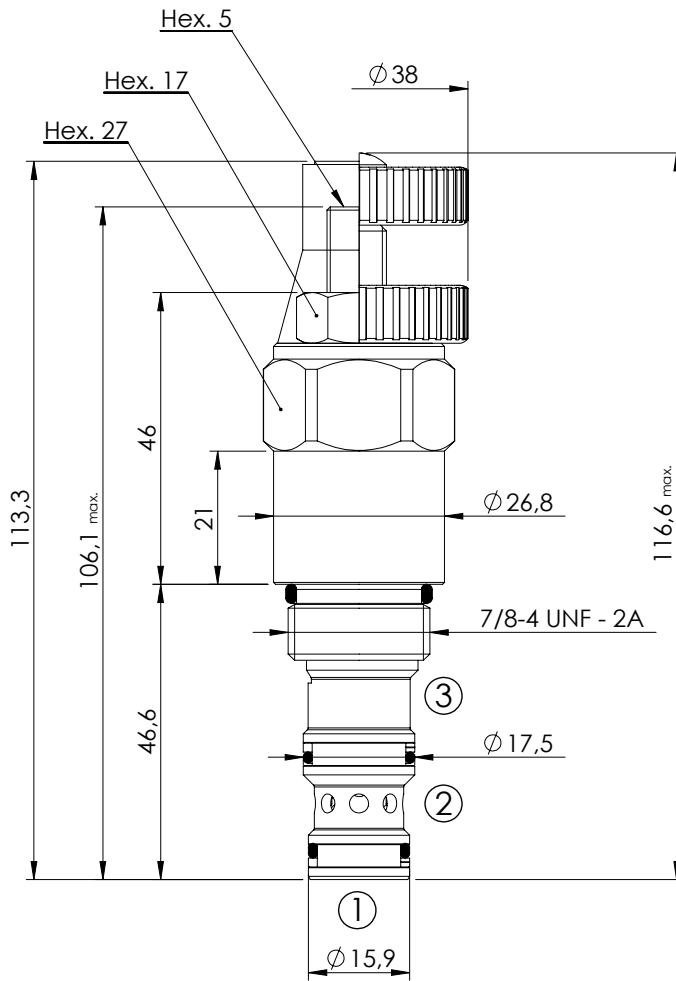

SPECIFICATIONS

Max. operating pressure:	350 bar
Rated flow:	60 l/min
Cavity:	SAE-10-3N
Weight:	0,26 kg
Installation torque:	55 - 62 Nm
Seal kit:	RA700092

SEALING CAP

Ordering code:
AT000022



OPTIONS

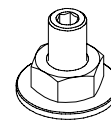

**Adjustment
with Screw**

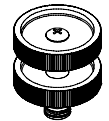

**Adjustment
with Handknob**

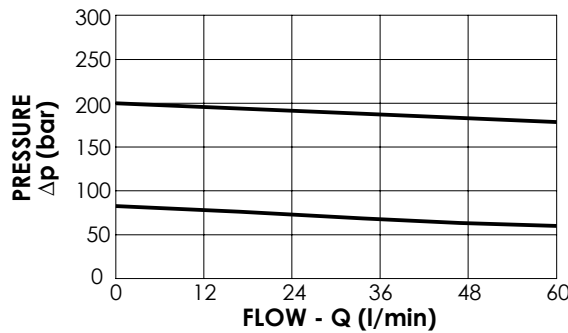

ORDERING CODES

Quick code	Description	Standard setting (bar)	Adjust. range (bar)	Pressure increase (bar/turn)	Options
CR000022	CPRR-060-PNNR-HN-S10-N300	200	70-350	114	Adjustment with Screw
CR000023	CPRR-060-PNNR-VN-S10-N300	200	70-350	114	Adjustment with Handknob
CR000024	CPRR-060-PNNR-HN-S10-N100	80	20-110	37	Adjustment with Screw
CR000021	CPRR-060-PNNR-VN-S10-N100	80	20-110	37	Adjustment with Handknob

PRESSURE REDUCING

CPRR-140-PNNR

**PILOT OPERATED
SPOOL TYPE**

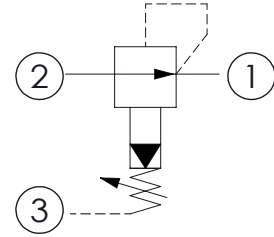
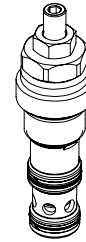
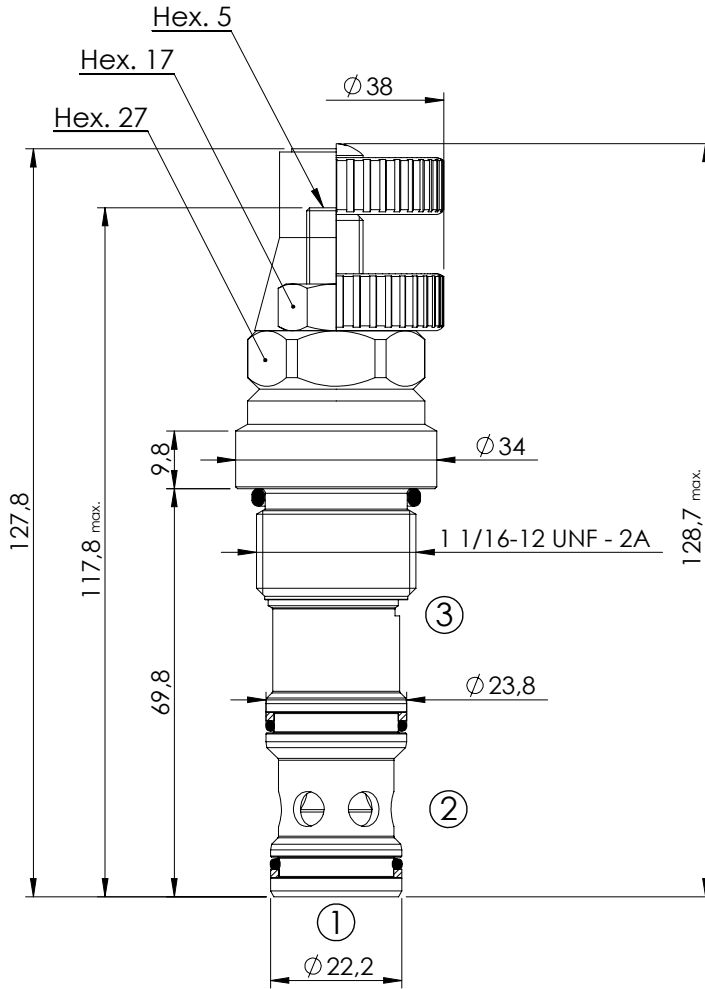

SPECIFICATIONS

Max. operating pressure:	350 bar
Rated flow:	140 l/min
Cavity:	SAE-12-3N
Weight:	0,35 kg
Installation torque:	80 - 95 Nm
Seal kit:	RA700093

SEALING CAP

Ordering code:
AT000022



OPTIONS

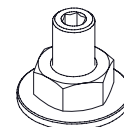

**Adjustment
with Screw**

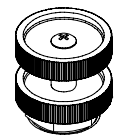

**Handknob
and locknut**

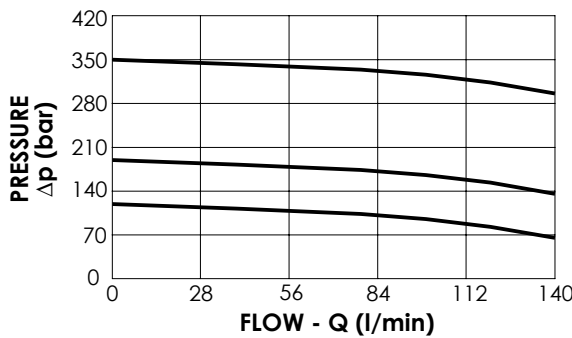

ORDERING CODES

Quick code	Description	Standard setting (bar)	Adjust. range (bar)	Pressure increase (bar/turn)	Options
CR000017	CPRR-140-PNNR-HN-S12-N350	300	140-350	114	Adjustment with Screw
CR000030	CPRR-140-PNNR-VN-S12-N350	300	140-350	114	Adjustment with Handknob
CR000016	CPRR-140-PNNR-HN-S12-N200	200	70-210	69	Adjustment with Screw
CR000027	CPRR-140-PNNR-VN-S12-N200	200	70-210	69	Adjustment with Handknob
CR000015	CPRR-140-PNNR-HN-S12-N100	100	10-120	37	Adjustment with Screw
CR000031	CPRR-140-PNNR-VN-S12-N100	100	10-120	37	Adjustment with Handknob

PRESSURE REDUCING IN BODY

KPRR-140-PNNR

**PILOT OPERATED
SPOOL TYPE**

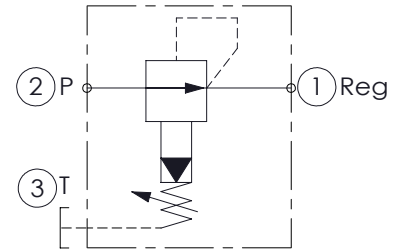
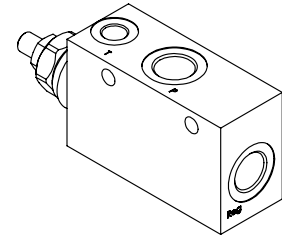
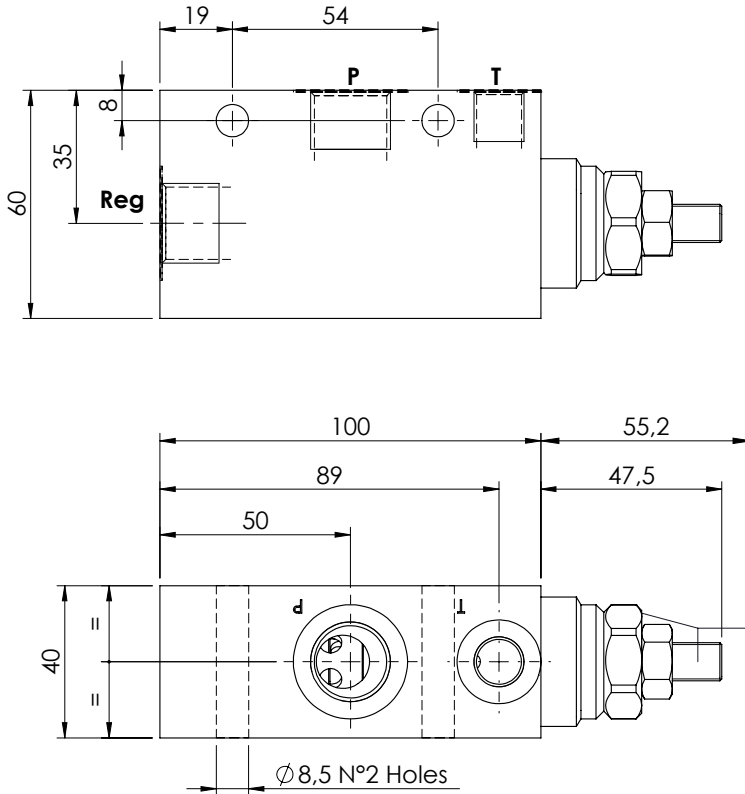

SPECIFICATIONS

Max. operating pressure:	250 bar
Rated flow:	140 l/min
Cavity:	SAE-12-3N
Weight:	0.8 kg
Manifold:	Aluminium

SEALING CAP

Ordering code:
AT000022

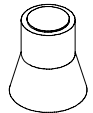

OPTIONS

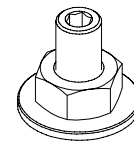

**Adjustment
with Screw**

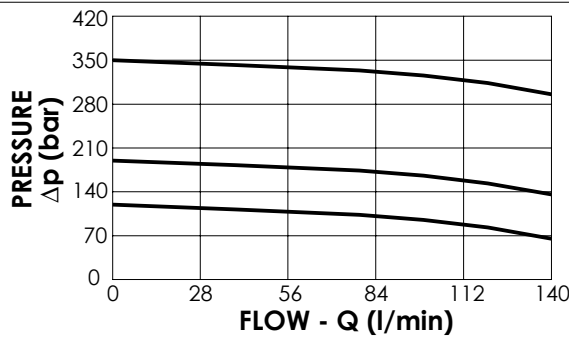

ORDERING CODES

Quick code	Description	Ports	Standard setting (bar)	Adjust. range (bar)	Pressure increase (bar/turn)	Options
KR000017	KPRR-140-PNNR-HN-G12-N350	P-Reg : G 1/2" T : G 1/4"	300	140-350	114	Adjustment with Screw
KR000019	KPRR-140-PNNR-HN-G12-N200	P-Reg : G 1/2" T : G 1/4"	200	70-210	69	Adjustment with Screw
KR000018	KPRR-140-PNNR-HN-G12-N100	P-Reg : G 1/2" T : G 1/4"	100	10-120	37	Adjustment with Screw



ATLANTIC
Fluid Tech

SECTION 20

Applications



1800-OILSOL
1800-645765

<https://oilsolutions.com.au/>

sales@oilsolutions.com.au

SECTION 20

APPLICATIONS



Chapter	Valve type	Page
20. 1	Excavators - Mini excavators	20.01.000
20. 2	All terrain cranes	20.02.000
20. 3	Concrete pump cranes	20.03.000
20. 4	Salt sprayers	20.04.000
20. 5	Garbage compactors	20.05.000
20. 6	Hook loaders	20.06.000



1800-OILSOL
1800-645765

<https://oilsolutions.com.au/>

sales@oilsolutions.com.au

SECTION 20. 1

APPLICATIONS - EXCAVATORS



Hydraulic scheme	Valve description	Valve type	Rated flow (l/min)	Max. pressure (bar)	Installation	Main port size or cavity type	Page
	MLST-160-RLGR	Right version with oil recovery	160	420	In line	G 3/4"	20.01.010
	MLST-250-RAUR	Right version	250	420	Flanged	3/4" SAE 6000	20.01.020
	MLST-250-RAUL	Left version	250	420	Flanged	3/4" SAE 6000	20.01.030
	BDEF-010-ALRV	Quick hitch	10	380	In line	1/4" Jis	20.01.040
	BNND-010-AERV	Quick hitch	10	350	In line	G 1/4"	20.01.050
	BNND-100-ALBE	Excavator attachment function	100	350	Flanged	G 1/2"	20.01.060
	BNND-200-ALBE	Excavator attachment function	200	350	Flanged	3/4" SAE 6000	20.01.070
	BNND-300-ALBE	Excavator attachment function	300	350	Flanged	1" SAE 6000	20.01.080
	MDRC-200-SLVN	Selector valve	200	500	Flanged	3/4" SAE 6000	20.01.090
	BPF0-060-ALSU	Flow regulated with relief valve	60	350	In line	G 1/2"	20.01.100

SECTION 20. 1

APPLICATIONS - EXCAVATORS



Hydraulic scheme	Valve description	Valve type	Rated flow (l/min)	Max. pressure (bar)	Installation	Main port size or cavity type	Page
	BNND-070-AERC	Solenoid activated	70	420	Flanged	3/4" SAE 3000/6000	20.01.110
	BNND-070-AERC	Solenoid activated	70	420	Flanged	1" SAE 3000/6000	20.01.120

EXCAVATORS VALVE

MLST-160-RLGR

WITH OIL RECOVERY

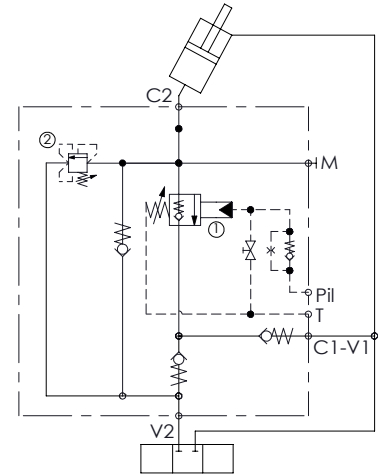
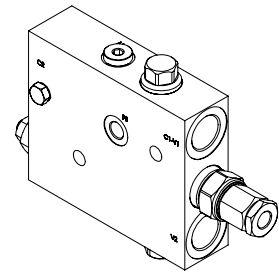
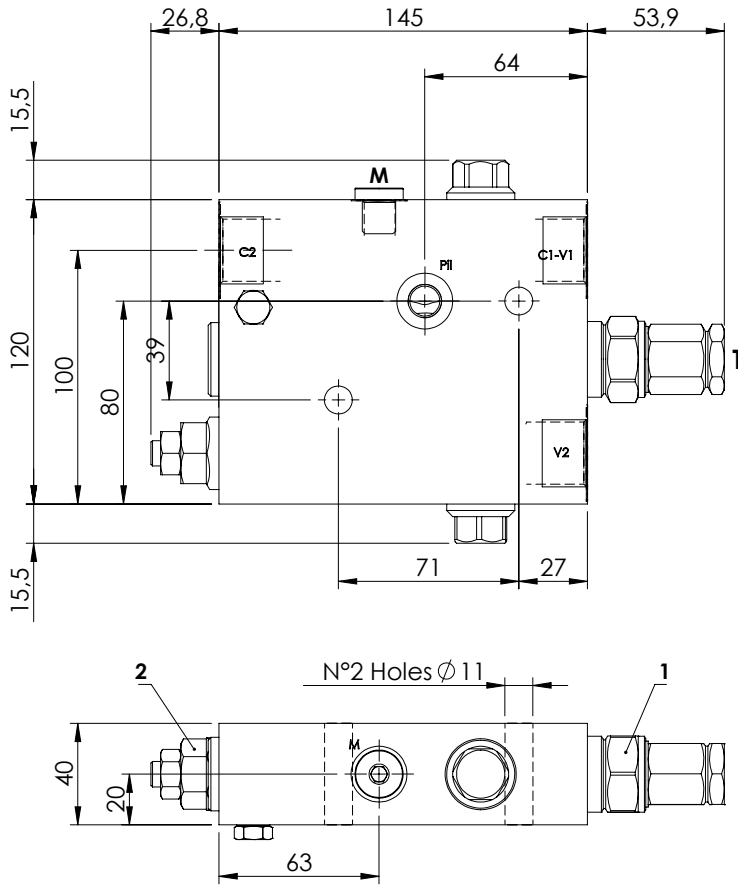

SPECIFICATIONS

Max. operating pressure:	420 bar
Rated flow:	160 l/min
Manifold:	Steel
Weight:	5,01 kg

NOTES

When correctly adjusted for the specific excavator installation, these valves meet the requirement of ISO 8643

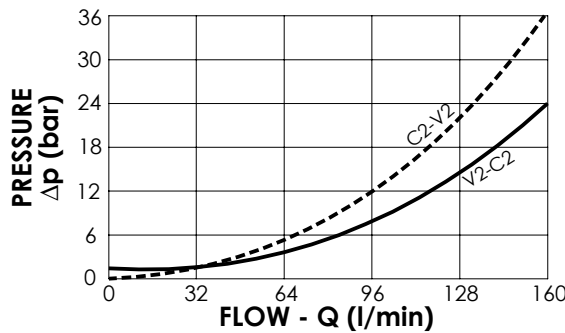

ORDERING CODES

Quick code	Description	Main ports size	Standard setting (bar)	Adjust. range (bar)	Pressure increase (bar/turn)
ML000165	MLST-160-RLGR-00-G34-N420	V2,C2: G 3/4" Pil,T,M: G 1/4"	① 350 Q=5 l/min ② 7.5 Crack. pr.	① 350-400 ② 3-15	① 72 ② 8

EXCAVATORS VALVE

MLST-250-RAUL

**FLANGED TYPE
3/4" SAE 6000
WITH OIL RECOVERY**

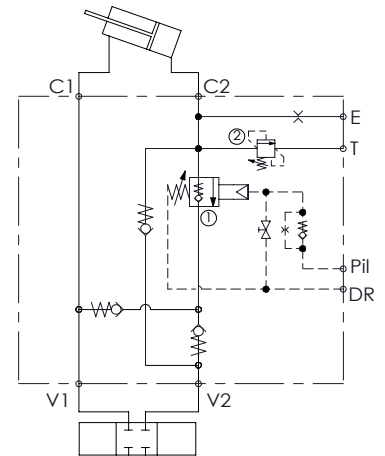
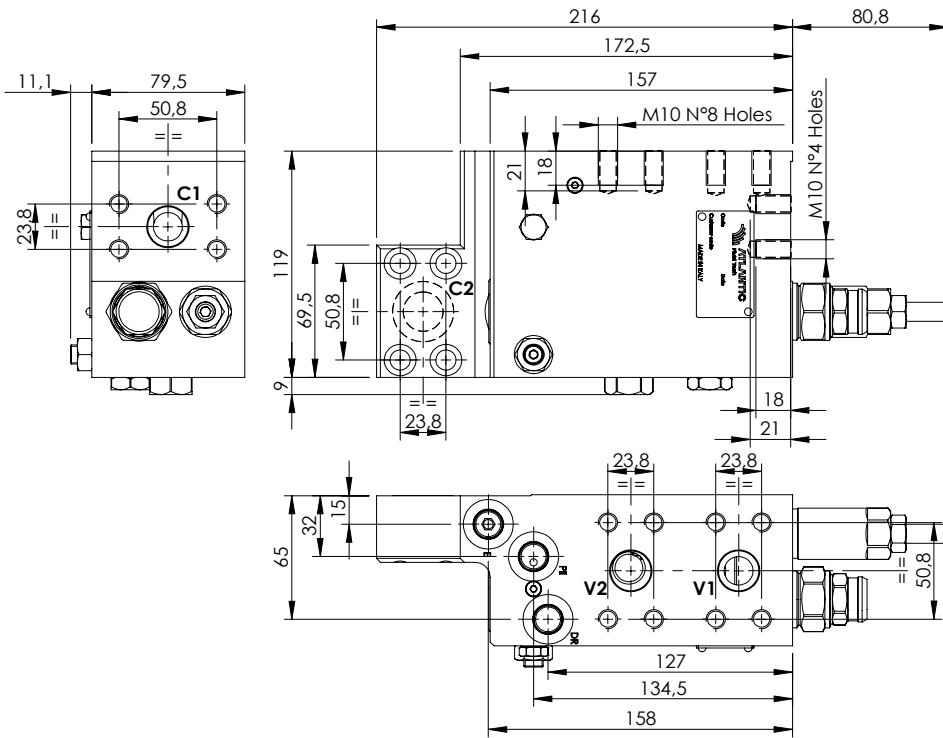
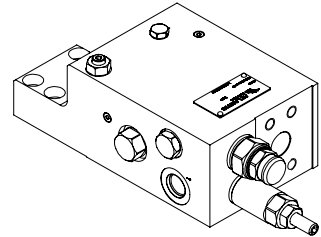
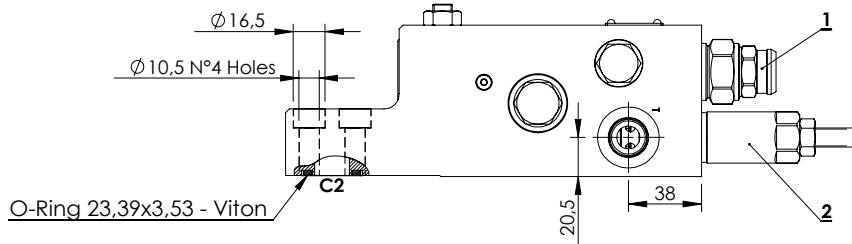

SPECIFICATIONS

Max. operating pressure:	420 bar
Rated flow:	250 l/min
Manifold:	Steel
Weight:	11,72 kg

NOTES

When correctly adjusted for the special excavator installation, these valves meet the requirement of ISO 8643

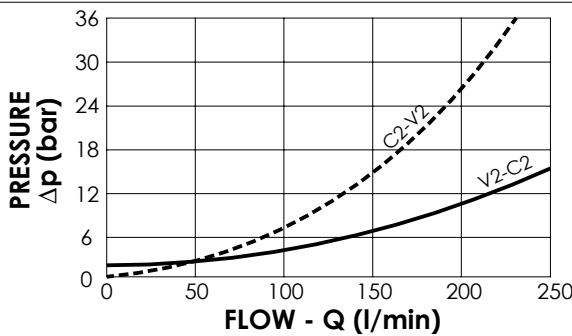

ORDERING CODES

Quick code	Description	Main ports size	Standard setting (bar)	Adjust. range (bar)	Pressure increase (bar/turn)
ML000266	MLST-250-RAUL-00-S34-N420	V1,V2,C1,C2: 3/4" SAE 6000 E,Pil,Dr: 9/16-18 UNF T: 3/4-16 UNF	① 7.9 Crack. pr. ② 395 Q=5 l/min	① 3-15 ② 150-420	① 6 ② 53

EXCAVATORS VALVE

BDEF-010-ALRV

AUXILIARY QUICK HITCH

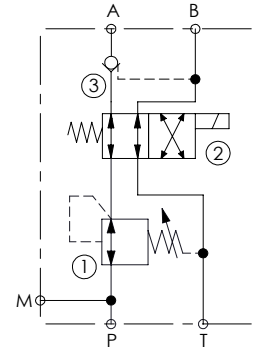
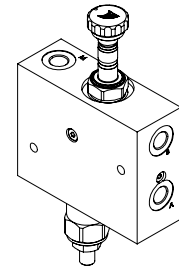
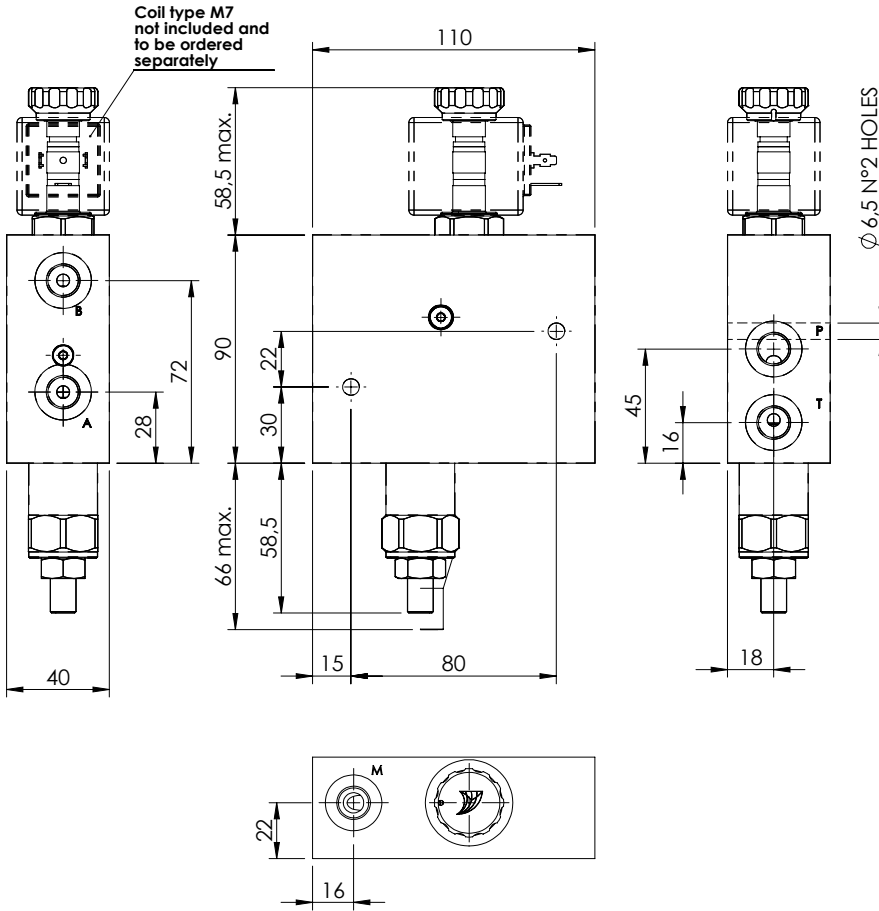

SPECIFICATIONS

Max. operating pressure:	380 bar
Rated flow:	10 l/min
Manifold:	Steel
Weight:	3,2 kg
Coil Type:	M7

SEALING CAP

Ordering code:
AT000022

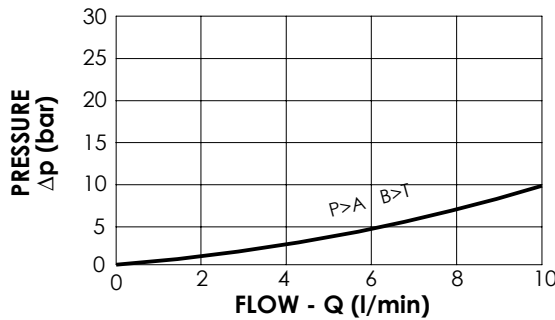
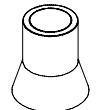

ORDERING CODES

Quick code	Description	Main ports size	Standard setting (bar, Q=5 l/min)	Adjustm. range (bar)	Pressure increase (bar/turn)
BD000095	BDEF-010-ALRV-NP-G14-V380	P, T, A, B, M: G 1/4"	340	70 - 350	114

EXCAVATORS VALVE

BNND-010-AERV

AUXILIARY QUICK HITCH

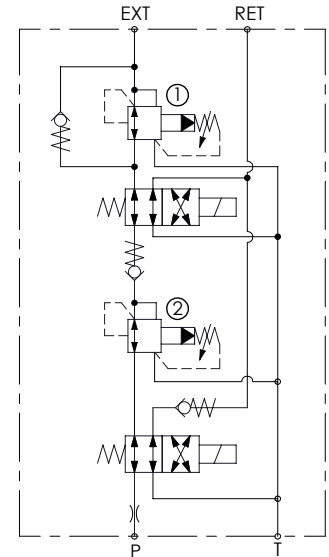
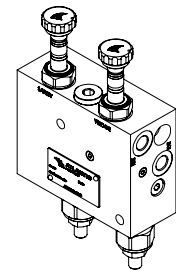
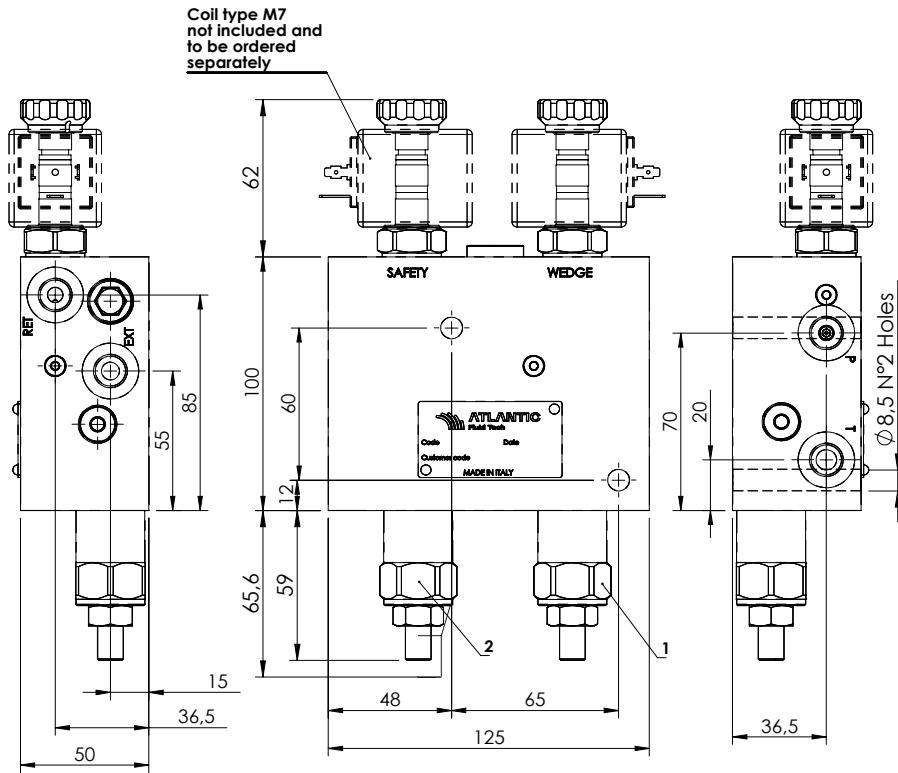

SPECIFICATIONS

Max. operating pressure:	350 bar
Rated flow:	10 l/min
Manifold:	Steel
Weight:	4,9 kg
Coil Type:	M7

SEALING CAP

Ordering code:
AT000022

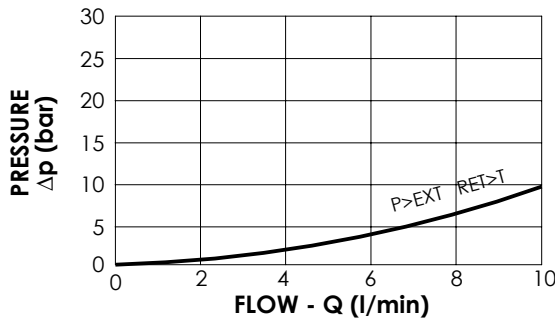
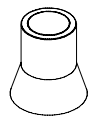

ORDERING CODES

Quick code	Description	Main ports size	Standard setting (bar, Q=5 l/min)	Adjustm. range (bar)	Pressure increase (bar/turn)
BD000207	BNND-010-AERV-NP-G14-N350	P,T,A,B M: G 1/4"	① :120 ② :240	70 - 350	114

EXCAVATORS VALVE

BNND-100-ALBE

EXCAVATOR ATTACHMENT
FUNCTION - G 1/2"



Solenoid operated valve
to be ordered separately

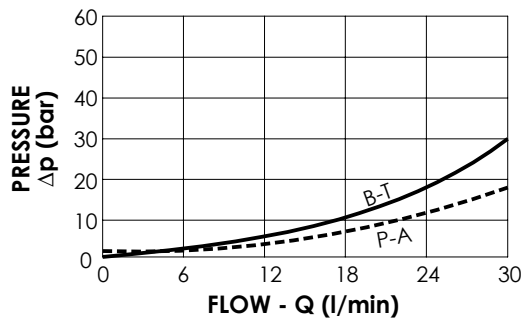
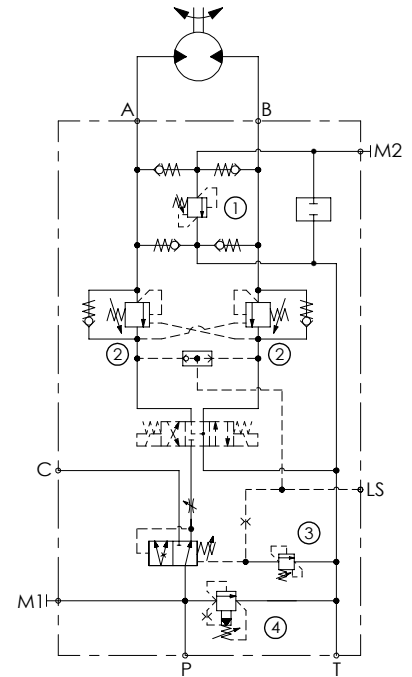
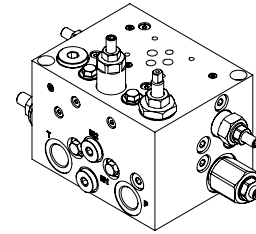
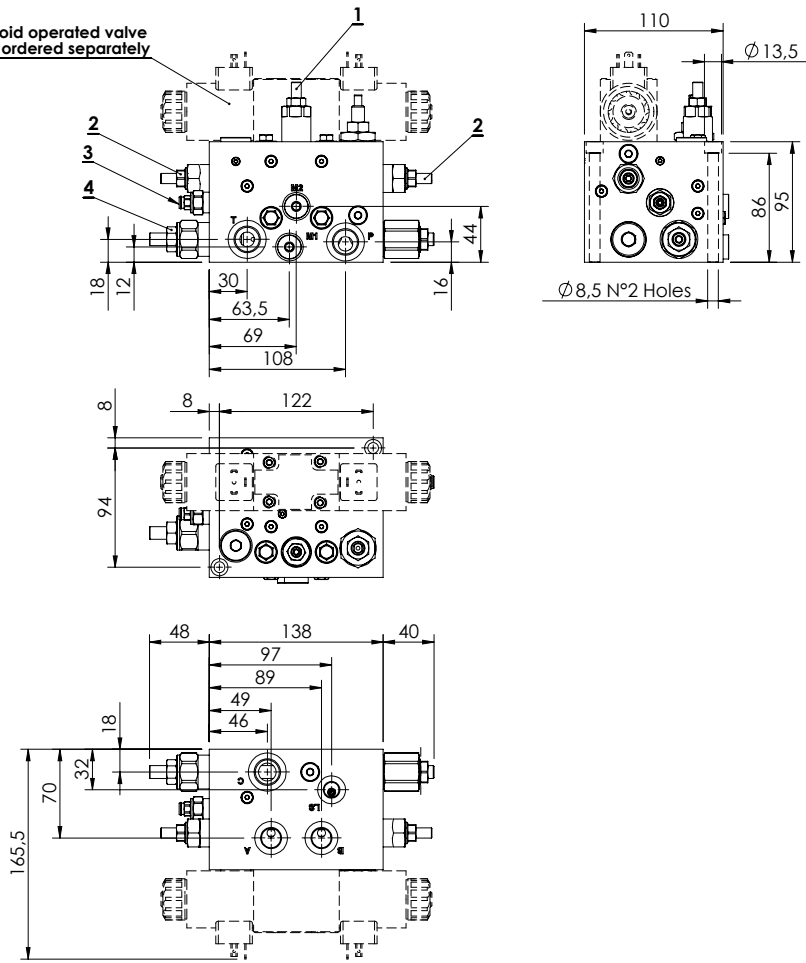

SPECIFICATIONS

Max. operating pressure:	350 bar
Rated flow:	Q max inlet : 100 l/min Q in A - B : 30 l/min
Manifold:	Steel zincplated
Weight:	10,96 kg

NOTES

Our spring on the compensator is adjustable from 5 to 15 bar, the max flow in A and B depend on the Δp curve of the electrical valve.

ORDERING CODES

Quick code	Description	Pilot ratio	Main ports size	Standard setting (bar, Q=5 l/min)	Adjust. range (bar)	Pressure increase (bar/turn)
BD000081	Excavator attachment function - G 1/2	4 : 1	P-T-C: G1/2" A-B: G3/8" M1-M2-LS: G1/4"	① 220 ③ 200 ② 260 ④ 250	①② 100-350 ③ 120-350 ④ 140-350	① 91 ③ 165 ② 184 ④ 114

EXCAVATORS VALVE

BNND-200-ALBE

**EXCAVATOR ATTACHMENT
FUNCTION - G 3/4" SAE 6000**



Solenoid operated valve
to be ordered separately

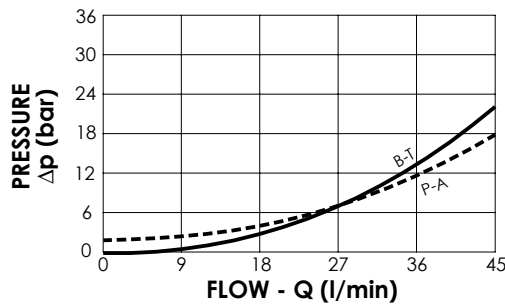
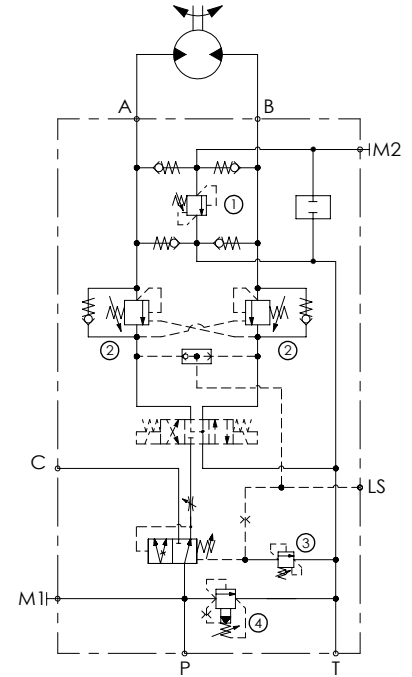
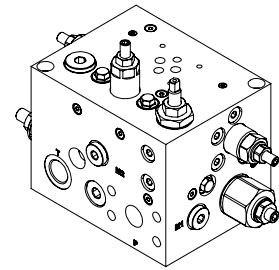
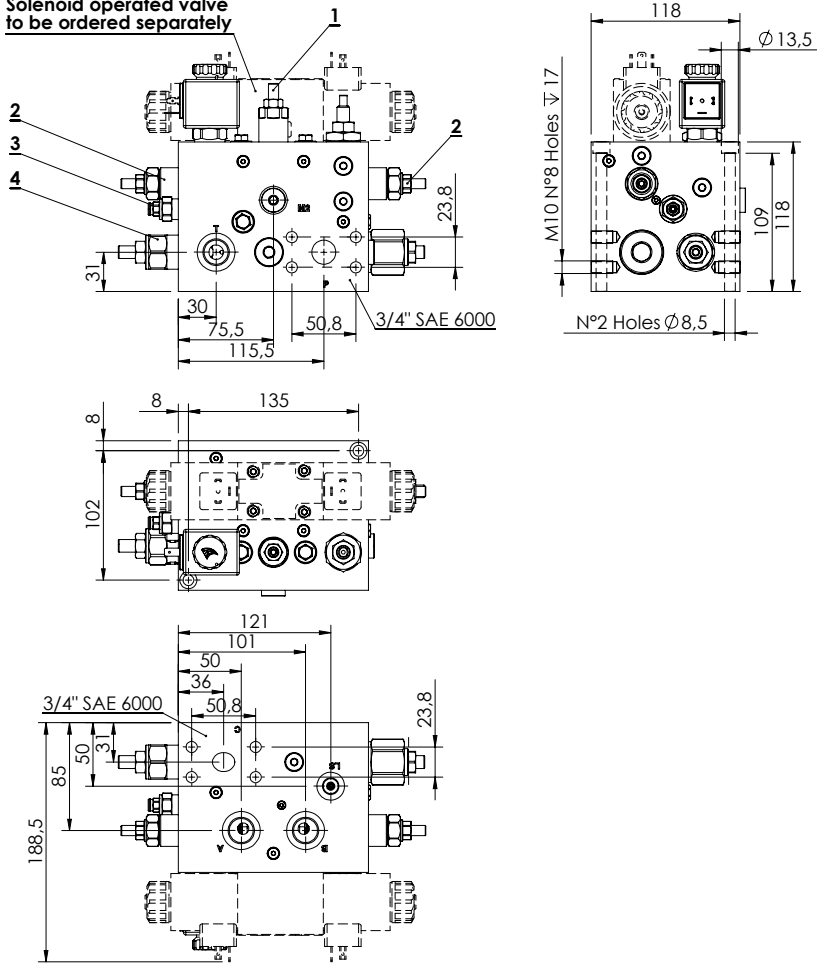

SPECIFICATIONS

Max. operating pressure:	350 bar
Rated flow:	Q max inlet : 200 l/min Q in A - B : 45 l/min
Manifold:	Steel zincplated
Weight:	16,01 kg

NOTES

Our spring on the compensator is adjustable from 5 to 15 bar, the max flow in A and B depend on the Δp curve of the electrical valve.

ORDERING CODES

Quick code	Description	Pilot ratio	Main ports size	Standard setting (bar, Q=5 l/min)	Adjust. range (bar)	Pressure increase (bar/turn)
BD000082	Excavator attachment function - 3/4" SAE 6000	4 : 1	P-C: G3/4" SAE 6000 A-B-T: G3/4" M1-M2-LS: G1/4"	① 220 ③ 200 ② 260 ④ 250	①② 100-350 ③ 120-350 ④ 140-350	① 91 ③ 165 ② 138 ④ 114

EXCAVATORS VALVE

BNND-300-ALBE

**EXCAVATOR ATTACHMENT
FUNCTION - G 1" SAE 6000**



Solenoid operated valve
to be ordered separately

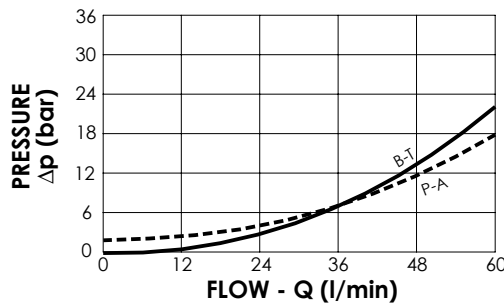
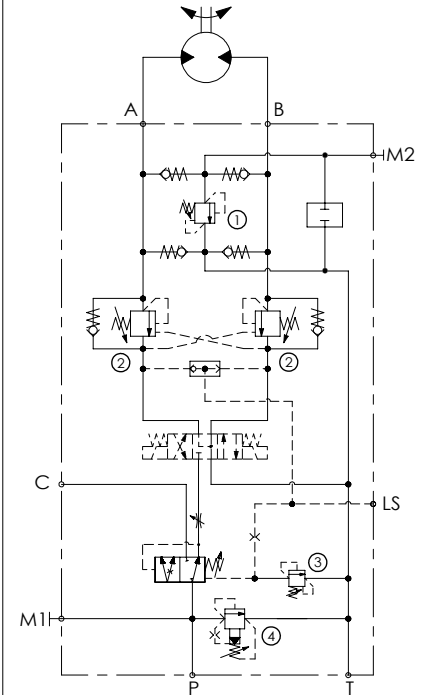
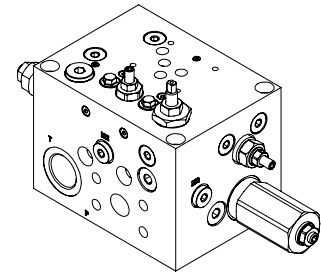
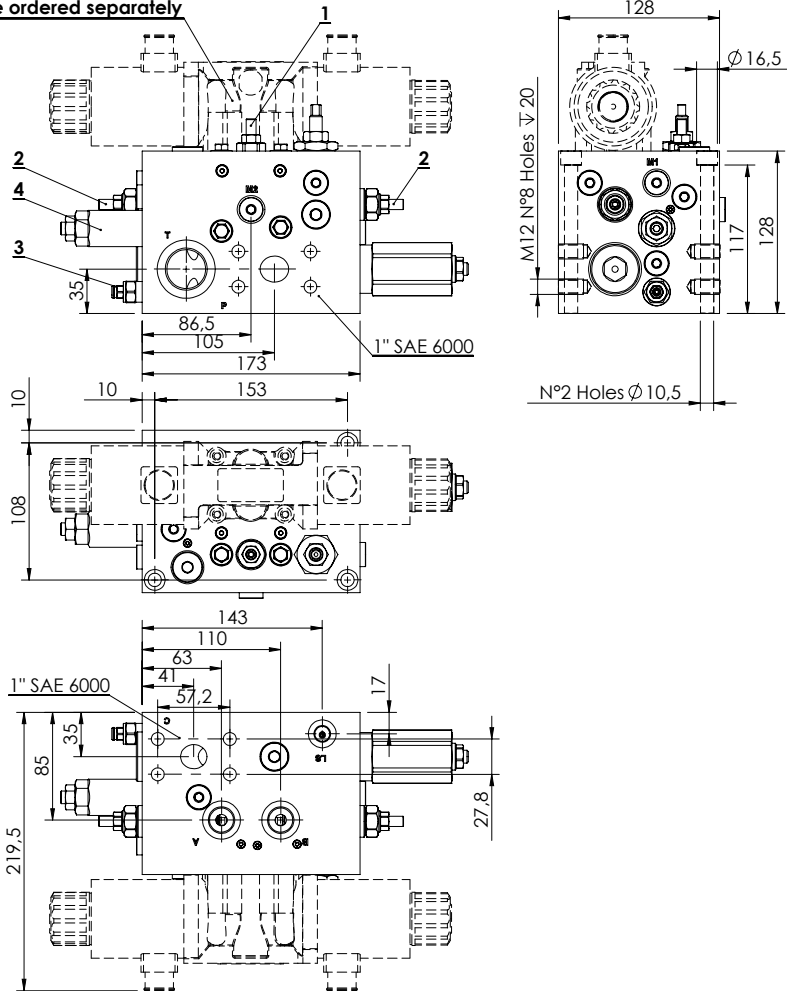

SPECIFICATIONS

Max. operating pressure: **350 bar**
 Rated flow: **Q max inlet : 300 l/min**
Q in A - B : 60 l/min
 Manifold: **Steel zincplated**
 Weight: **26,76 kg**

NOTES

Our spring on the compensator is adjustable from 5 to 15 bar, the max flow in A and B depend on the Δp curve of the electrical valve.

ORDERING CODES

Quick code	Description	Pilot ratio	Main ports size	Standard setting (bar, Q=5 l/min)	Adjust. range (bar)	Pressure increase (bar/turn)
BD000083	Excavator attachment function - 1" SAE 6000	4 : 1	P-C: G1" SAE 6000 A-B-T: G1/2" M1-M2-LS: G1/4"	① 220 ③ 200 ② 260 ④ 250	①② 100-350 ③ 120-350 ④ 140-270	① 91 ③ 165 ② 138 ④ 49

EXCAVATORS VALVE

MDRC-200-SLVN

**AUXILIARY
SELECTOR VALVE**

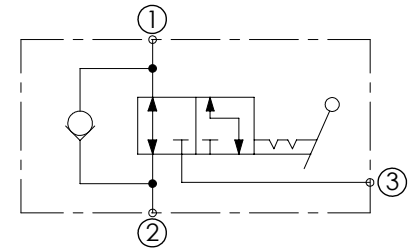
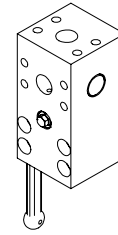
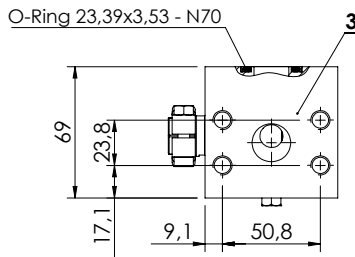
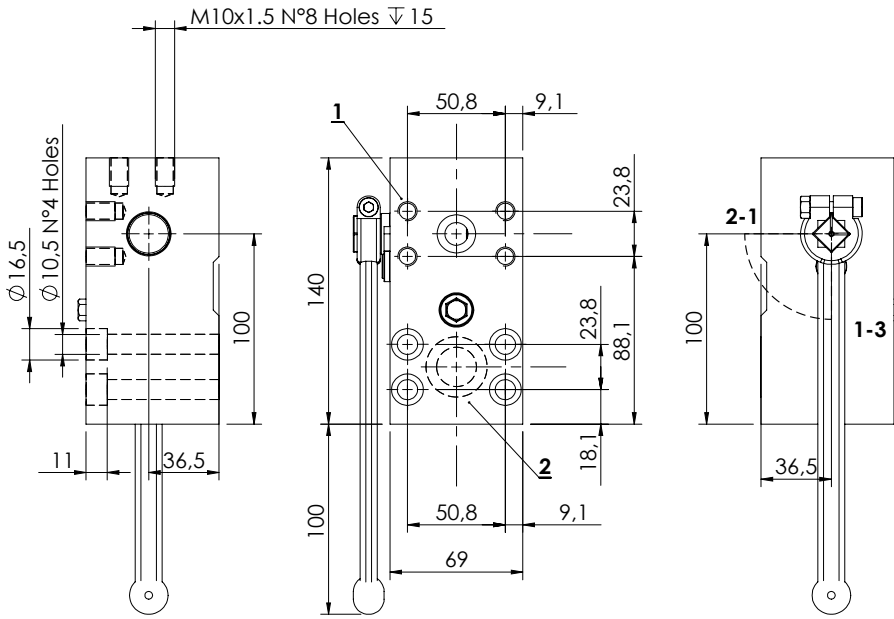

SPECIFICATIONS

Max. operating pressure:	500 bar
Rated flow:	200 l/min
Manifold:	Steel
Weight:	4,86 kg

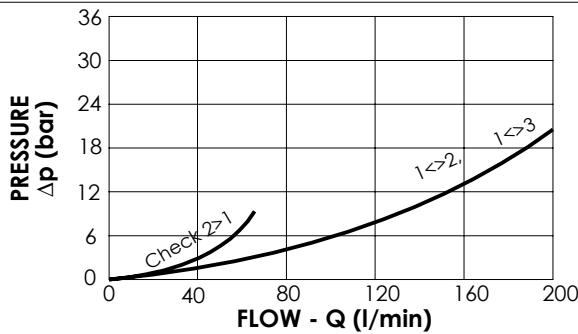

NOTES

1 to 2, leakage in 3: 20 cc @ 100 bar
1 to 3, leakage in 2: 20 cc @ 100 bar

Oil specification: 46 cSt
Oil temperature: 35°C

Handle supplied separately,
not attached to the block.

ORDERING CODES

Quick code	Description	Main ports size	
MD000072	MDRC-200-SLVN-NP-S34-N500	3/4" SAE 6000	

EXCAVATORS VALVE

BPFD-060-ALSU

FLOW REGULATOR WITH RELIEF VALVE

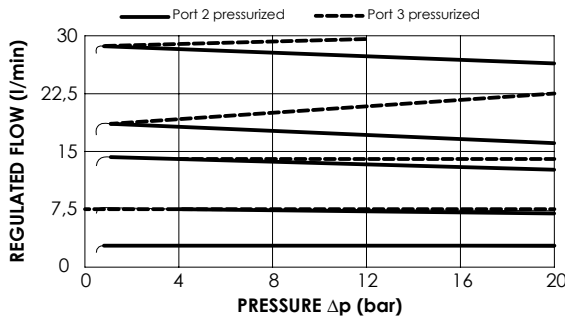
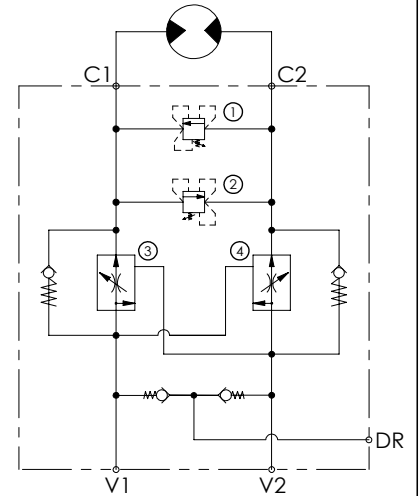
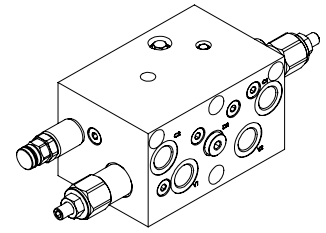
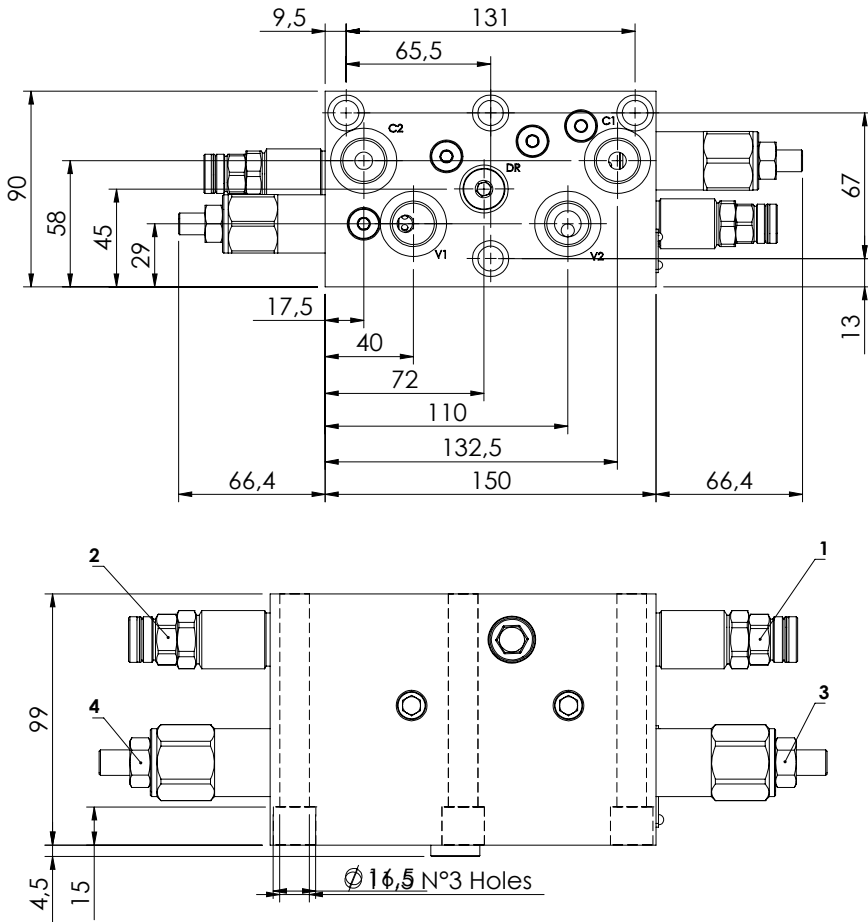

SPECIFICATIONS

Max. operating pressure:	350 bar
Rated flow:	60 l/min
Regulated Flow:	30 l/min
Manifold:	Steel
Weight:	9,79 kg
Coil:	

ORDERING CODES

Quick code	Description	Main ports size	Setting range (bar)	Adjustment range (bar)	Pressure increase (bar/turn)
BP000039	BPFD-060-ALSU-FT-G12-N350	V1,V2,C1,C2: G 1/2" DR: G 1/4"	90	30-100	20

EXCAVATORS VALVE

BNND-070-AERC

**SOLENOID ACTIVATED
FLANGED**

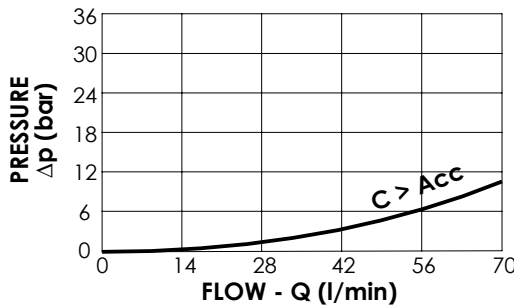
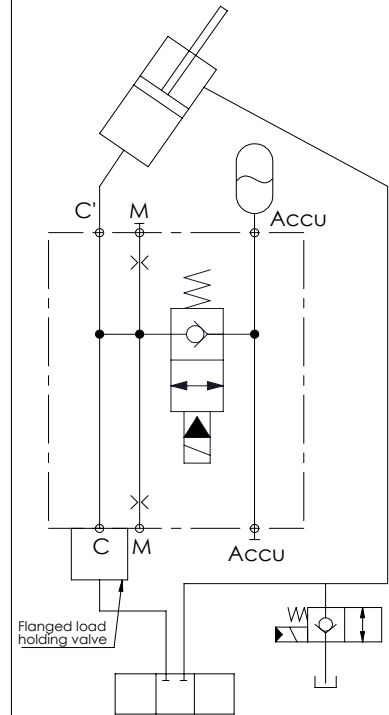
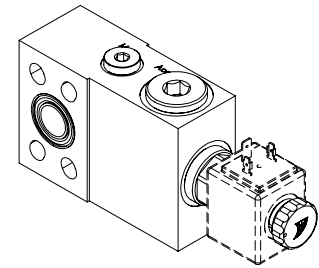
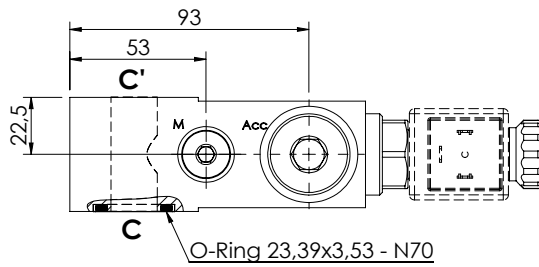
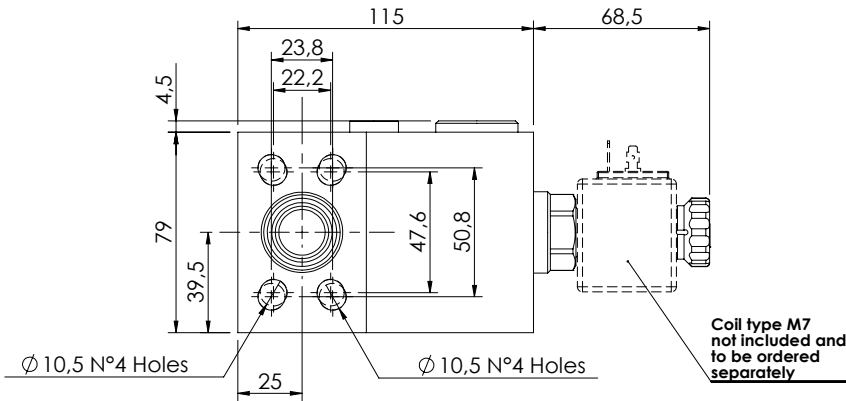
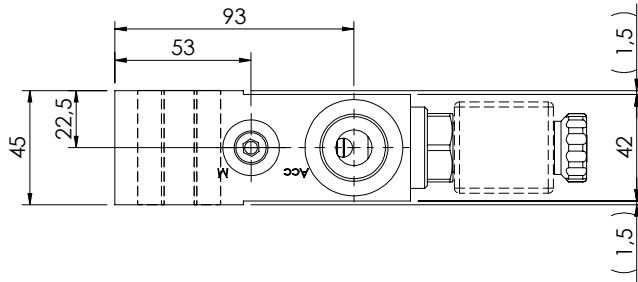

SPECIFICATIONS

Max. operating pressure:	420 bar
Rated flow:	70 l/min
Manifold:	Steel
Weight:	2,96 kg
Coil type:	M7

ORDERING CODES

Quick code	Description	Main ports size
BD000065	BNND-070-AERC-00-S34-N350	C,C': 3/4" SAE 3000/6000 Acc: G 3/4" M: G 1/4"

EXCAVATORS VALVE

BNND-070-AERC

SOLENOID ACTIVATED
FLANGED

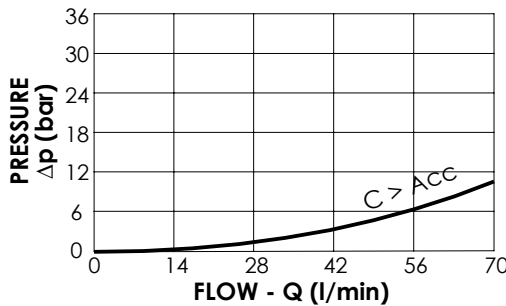
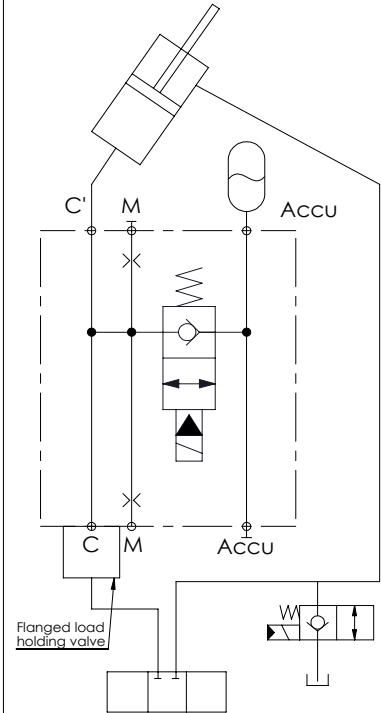
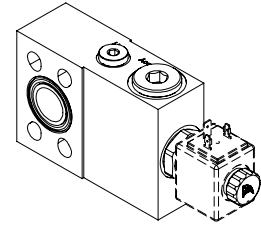
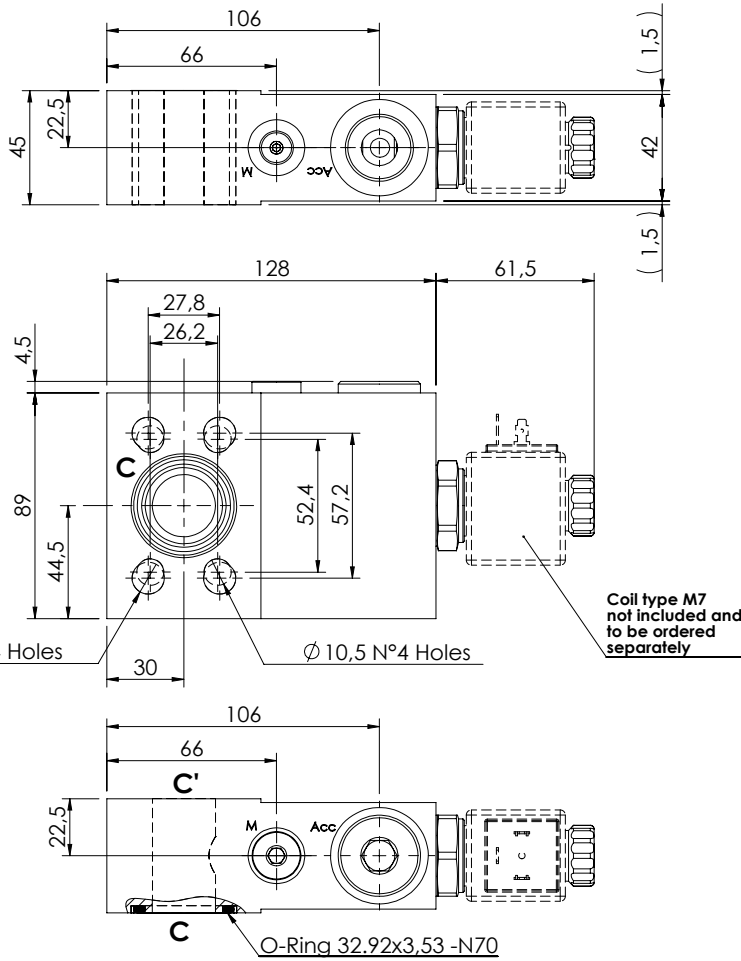

SPECIFICATIONS

Max. operating pressure:	420 bar
Rated flow:	70 l/min
Manifold:	Steel
Weight:	3,54 kg
Coil type:	M7

ORDERING CODES

Quick code	Description	Main ports size
BD000066	BNND-070-AERC-00-S10-N350	C, C': 1" SAE 3000/6000 Acc: G 3/4" M: G 1/4"

SECTION 20. 2

APPLICATIONS - ALL TERRAIN CRANES



Hydraulic scheme	Valve description	Valve type	Rated flow (l/min)	Max. pressure (bar)	Installation	Main port size or cavity type	Page
	MLST-250-AAGN	-	250	350	In line	3/4" SAE 6000	20.02.010

ALL TERRAIN CRANES

MLST-250-AAGN

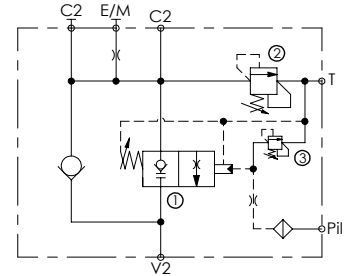
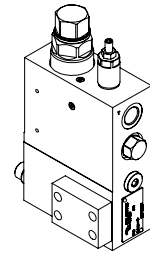
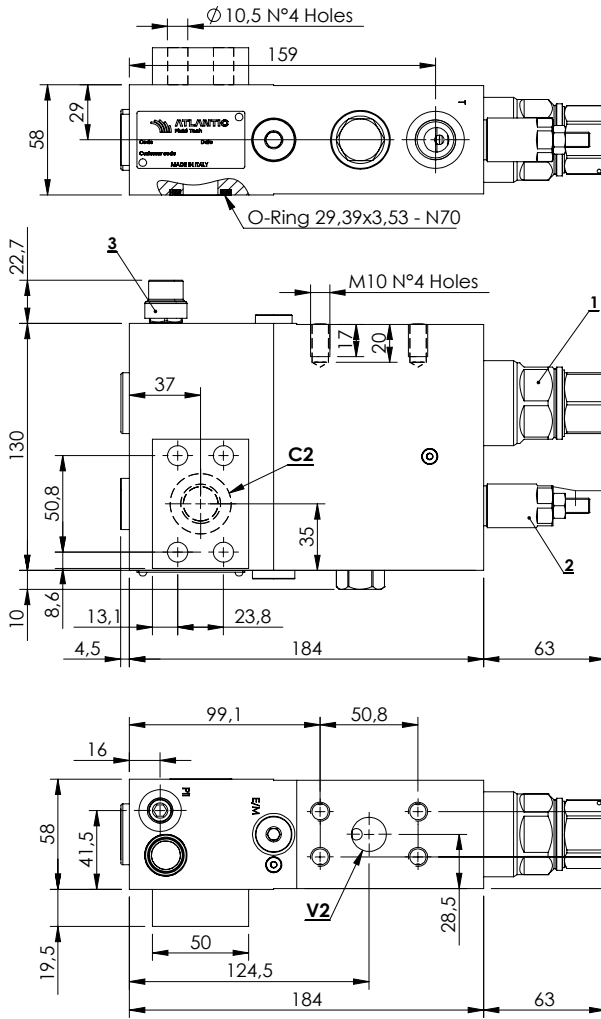

SPECIFICATIONS

Max. operating pressure:	350 bar
Rated flow:	250 l/min
Manifold:	Steel
Weight:	10,56 kg

SEALING CAP

Ordering code:
AT000020

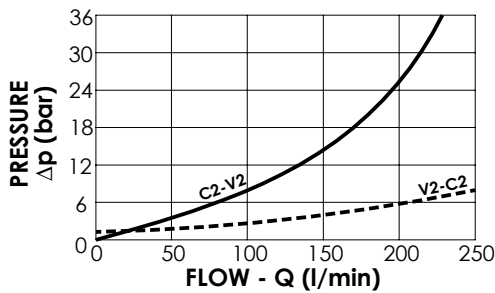
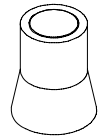

NOTES

When correctly adjusted for the special excavator installation, these valves meet the requirement of ISO 8643

Piston with grooves

ORDERING CODES

Quick code	Description	Main ports size	Standard setting (bar)	Adjust. range (bar)	Pressure increase (bar/turn)
ML000212	MLST-250-AAGN-00-S34-N350	V2,C2: 3/4" SAE 6000 E/M,Pii: G 1/4" T: G 1/2"	① 9 Q=5 l/min ③ 20 C.P. ② 350 Q=5 l/min	① 2-15 ③ 10-40 ② 100-350	① 1,6 ③ 22 ② 91

SECTION 20. 3

APPLICATIONS - CONCRETE PUMP CRANES



Hydraulic scheme	Valve description	Valve type	Rated flow (l/min)	Max. pressure (bar)	Installation	Main port size or cavity type	Page
	MBSN-060-ZAPF	-	60	350	Flanged	G 3/8"	20.03.010
	MBSN-060-AAST	-	60	350	Flanged	Ø9	20.03.020
	MBSN-060-AASA	-	60	350	Flanged	Ø9	20.03.030
	MBSN-060-APST	-	60	350	Flanged	M22x1,5	20.03.040
	MBSN-080-APST	-	80	350	Flanged	M22x1,5	20.03.050
	MBSN-060-ZENV	-	60	350	Flanged	Ø9	20.03.060

CONCRETE PUMP CRANES

MBSN-060-ZAPF

SINGLE ACTING
FLANGED

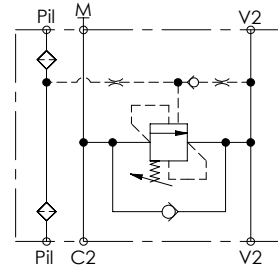
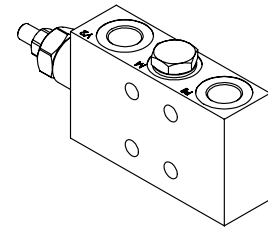
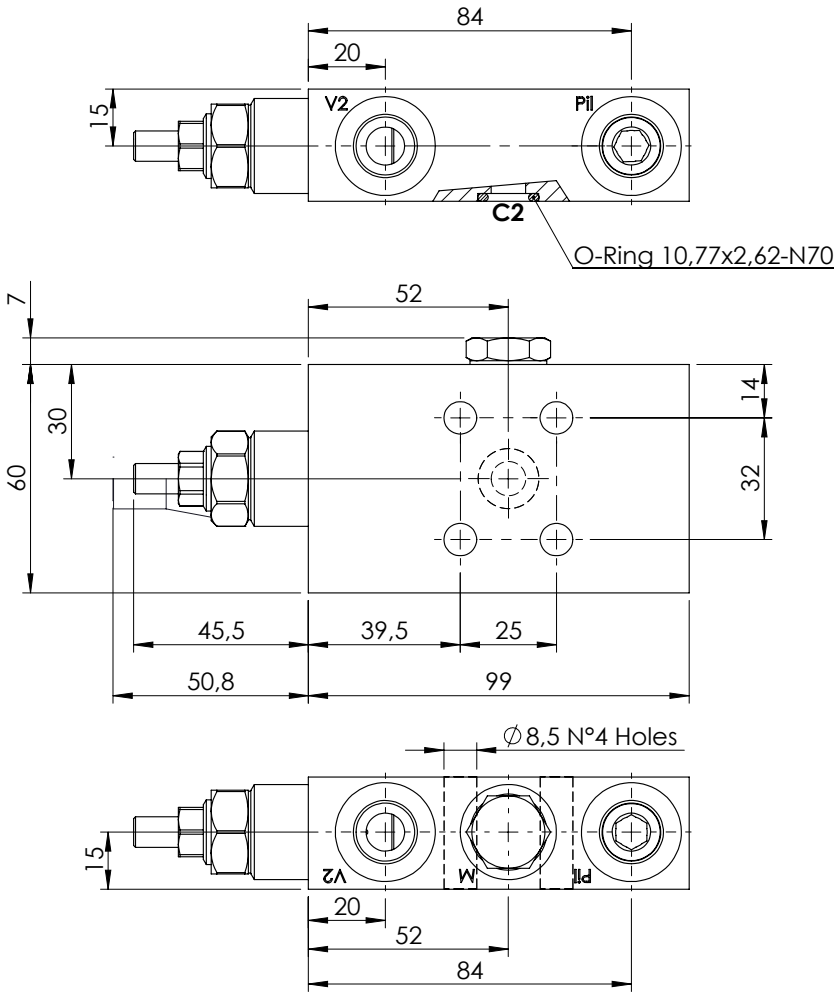

SPECIFICATIONS

Max. operating pressure:	350 bar
Rated flow:	60 l/min
Manifold:	Aluminium
Weight:	0,56 kg

SEALING CAP

Ordering code:
AT000020

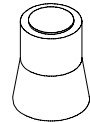

NOTES

Setting: at least 1.3 times the load induced pressure
Pilot ratio: 4,2:1
Operative pilot ratio: 2,1:1

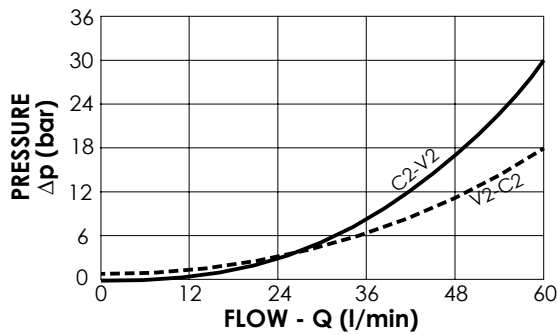

ORDERING CODES

Quick code	Description	Main ports size	Standard setting (bar, Q=5 l/min)	Adjust. range (bar)	Pressure increase (bar/turn)
MB000461	MBSN-060-ZAPF-02-G38-N350	V2,Pil:G 3/8" M:M12x1,5	340	100-350	138

CONCRETE PUMP CRANES

MBSN-060-AAST

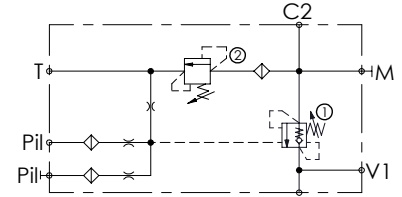
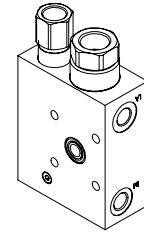
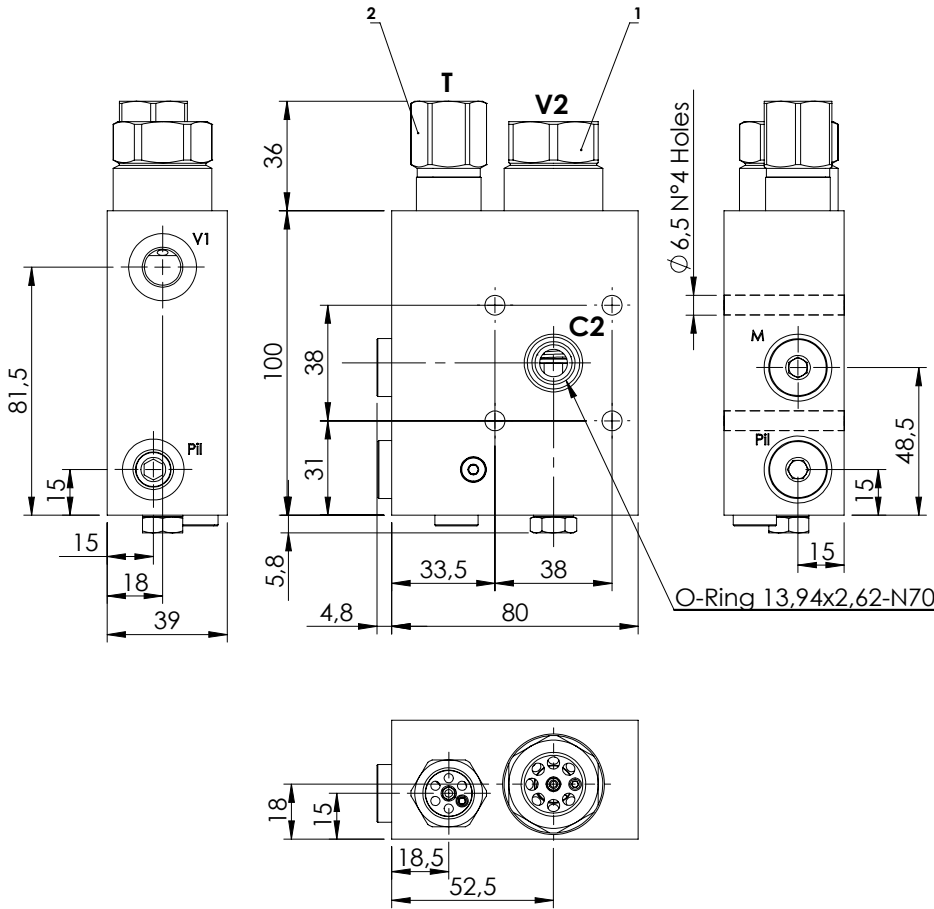

SPECIFICATIONS

Max. operating pressure:	500 bar
Rated flow:	60 l/min
Manifold:	Steel
Weight:	2,42 kg

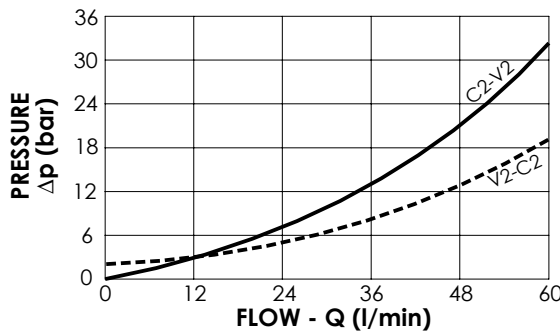

NOTES

Setting: at least 1.3 times the load induced pressure

Pilot ratio: 7:1
Operated pilot ratio: 3,6:1

ORDERING CODES

Quick code	Description	Main ports size	Standard setting (bar, Q=5 l/min)	Adjust. range (bar)	Pressure increase (bar/turn)
MB000101	MBSN-060-AAST-04-G12-N500	V1,Pil,M:G1/4" T:G3/8" V2:G1/2" C2:Ø9	①:450 ②:450	①:200-450 ②:150-500	①:366 ②:167

CONCRETE PUMP CRANES

MBSN-060-AASA

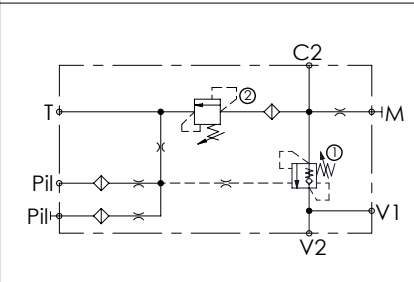
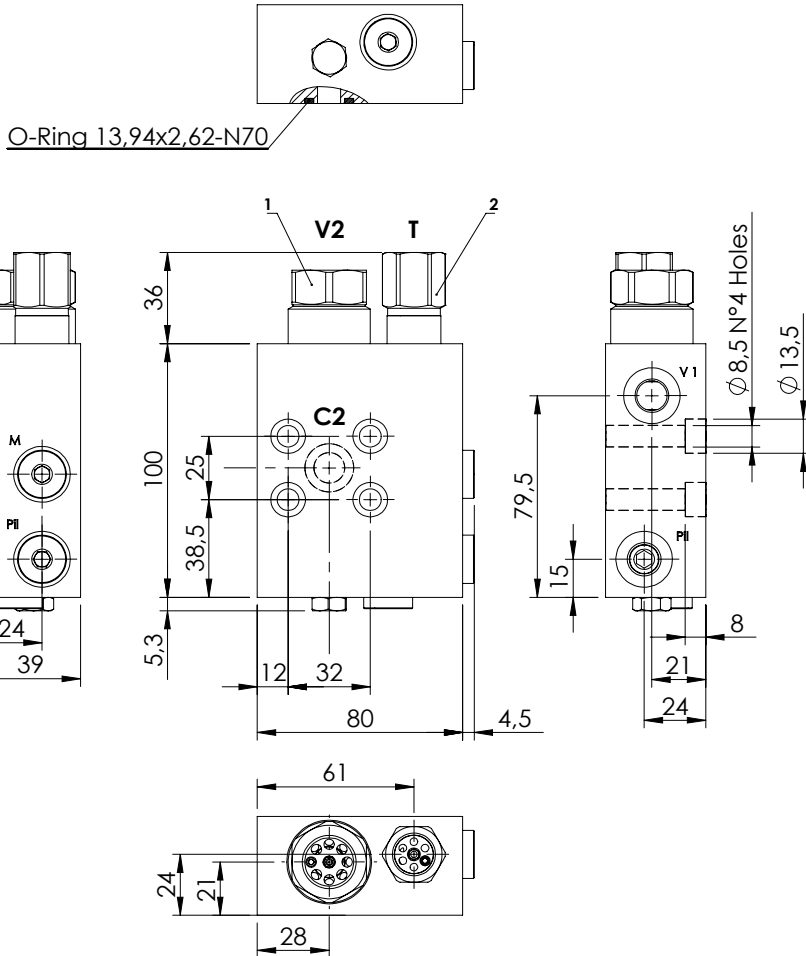
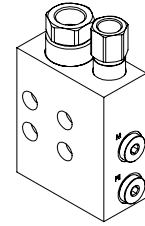

SPECIFICATIONS

Max. operating pressure:	500 bar
Rated flow:	60 l/min
Manifold:	Steel
Weight:	2,38 kg

NOTES

Setting: at least 1.3 times the load induced pressure

Pilot ratio: 7:1
Operated pilot ratio: 2,5:1

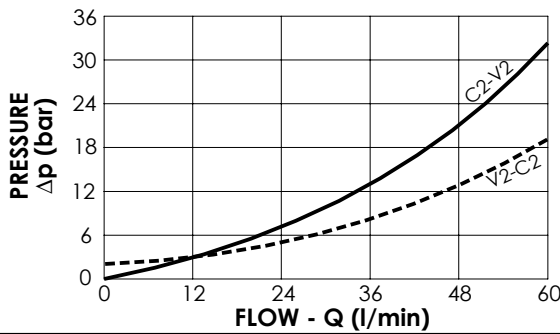

ORDERING CODES

Quick code	Description	Main ports size	Standard setting (bar, Q=5 l/min)	Adjust. range (bar)	Pressure increase (bar/turn)
MB000088	MBSN-060-AASA-02-G12-N500	V2: G1/2" T:G 3/8" M: G1/8" V1,Pil: G1/4" C2: Ø9	① :420 ② :280	① :200-450 ② :100-350	① :366 ② :102

CONCRETE PUMP CRANES

MBSN-060-APST

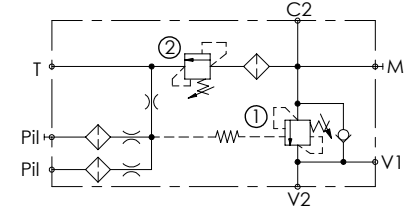
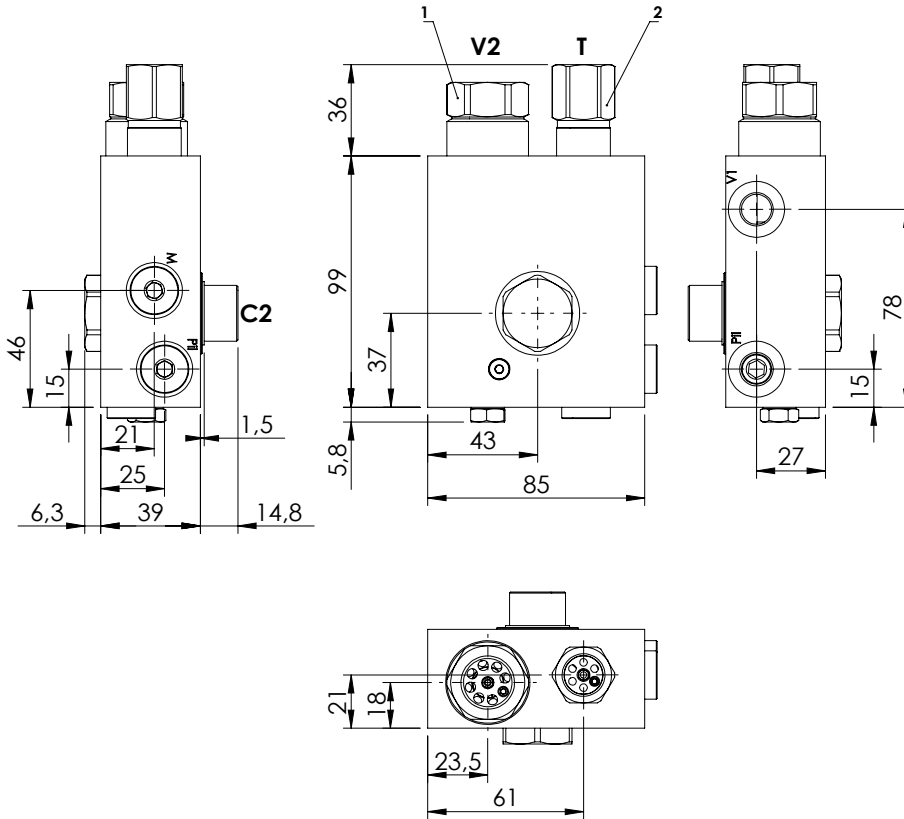
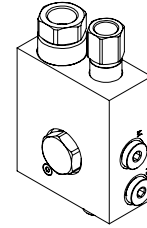

SPECIFICATIONS

Max. operating pressure:	420 bar
Rated flow:	60 l/min
Manifold:	Steel
Weight:	2,61 kg

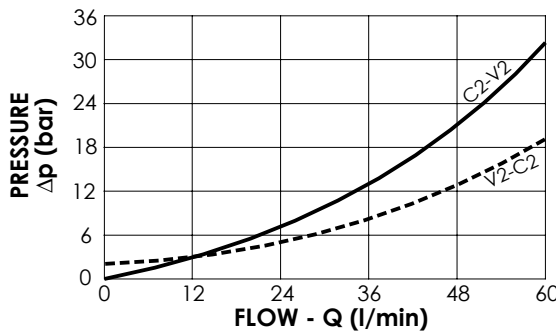

NOTES

Setting: at least 1.3 times the load induced pressure

Pilot ratio: 7:1

ORDERING CODES

Quick code	Description	Oper. pilot ratio	Main ports size	Standard setting (bar, Q=5 l/min)	Adjust. range (bar)	Pressure increase (bar/turn)
MB000823	MBSN-060-APST-01-M22-N420	1,5:1	T:G3/8" V2:G1/2" V1,M,Pil:G1/4" C2:M22x1,5	① :380 ② :400	① :200-420 ② :150-500	① :366 ② :167
MB000824	MBSN-060-APST-02-M22-N420	2,3:1	T:G3/8" V2:G1/2" V1,M,Pil:G1/4" C2:M22x1,5	① :210 ② :230	① :200-420 ② :150-500	① :366 ② :167

CONCRETE PUMP CRANES

MBSN-060-ZENV

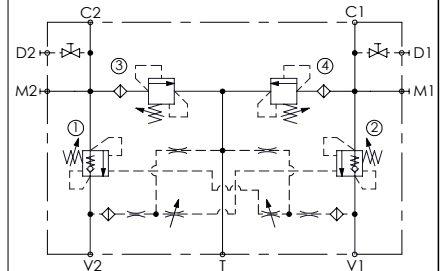
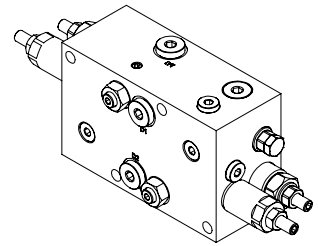
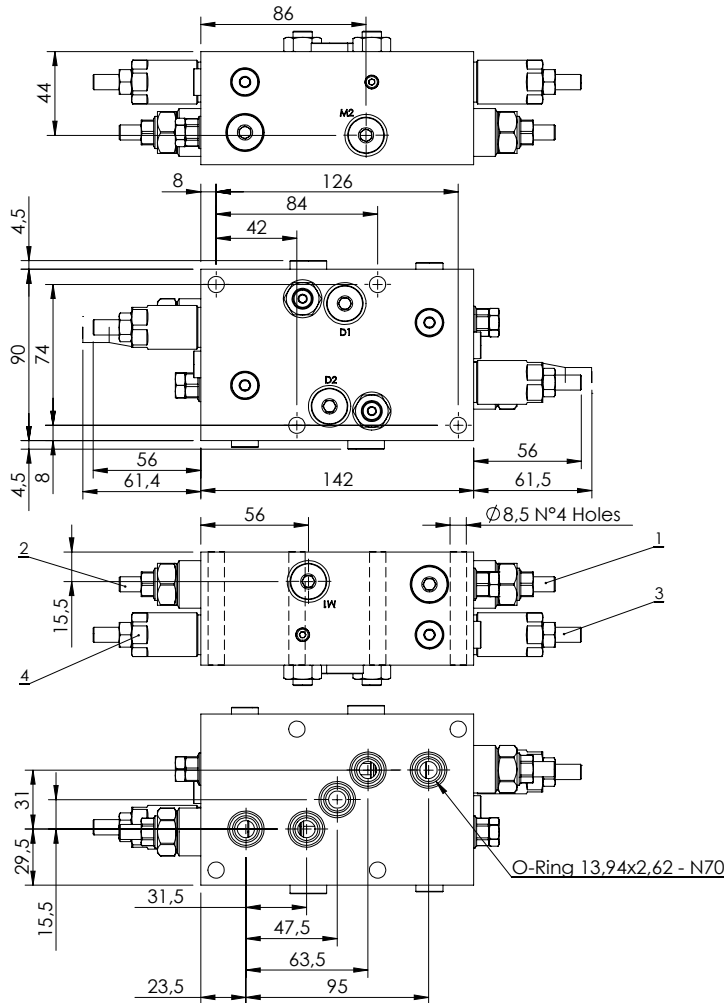

SPECIFICATIONS

Max. operating pressure:	500 bar
Rated flow:	60 l/min
Manifold:	Aluminium
Weight:	2,63 kg

SEALING CAP

Ordering code:
AT000020

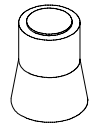

NOTES

Setting: at least 1.3 times the load induced pressure

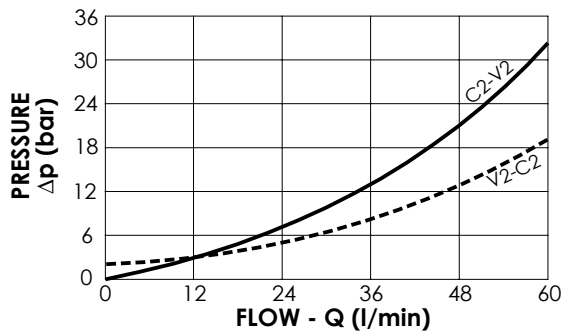

ORDERING CODES

Quick code	Description	Pilot ratio	Main ports size	Standard setting (bar, Q=5 l/min)	Adjust. range (bar)	Pressure increase (bar/turn)
MB000931	MBDN-060-ZENV-04-TPF-N500	4:1	C1,C2,V1,V2,T:Ø9 M1,M2:G1/4"	①②:400 ③④:390	①②:250-420 ③④:100-350	①②:150 ③④:106



1800-OILSOL
1800-645765

<https://oilsolutions.com.au/>

sales@oilsolutions.com.au

SECTION 20. 4

APPLICATIONS - SALT SPRAYERS



Hydraulic scheme	Valve description	Valve type	Rated flow (l/min)	Max. pressure (bar)	Installation	Main port size or cavity type	Page
	BNFN-140-LPNR-02	Proportional valve	140	250	In line	M26x1,5	20.04.010
	BNFN-140-LPNR-03	Proportional valve	140	250	In line	M27x1,5	20.04.020
		Directional valve	40	320	In line	G 3/8"	20.04.030
		Directional valve	40	320	In line	G 3/8"	20.04.040

SALT SPRAYER VALVE

BNFN-140-LPNR

PROPORTIONAL VALVE

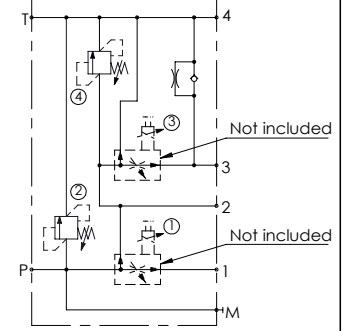
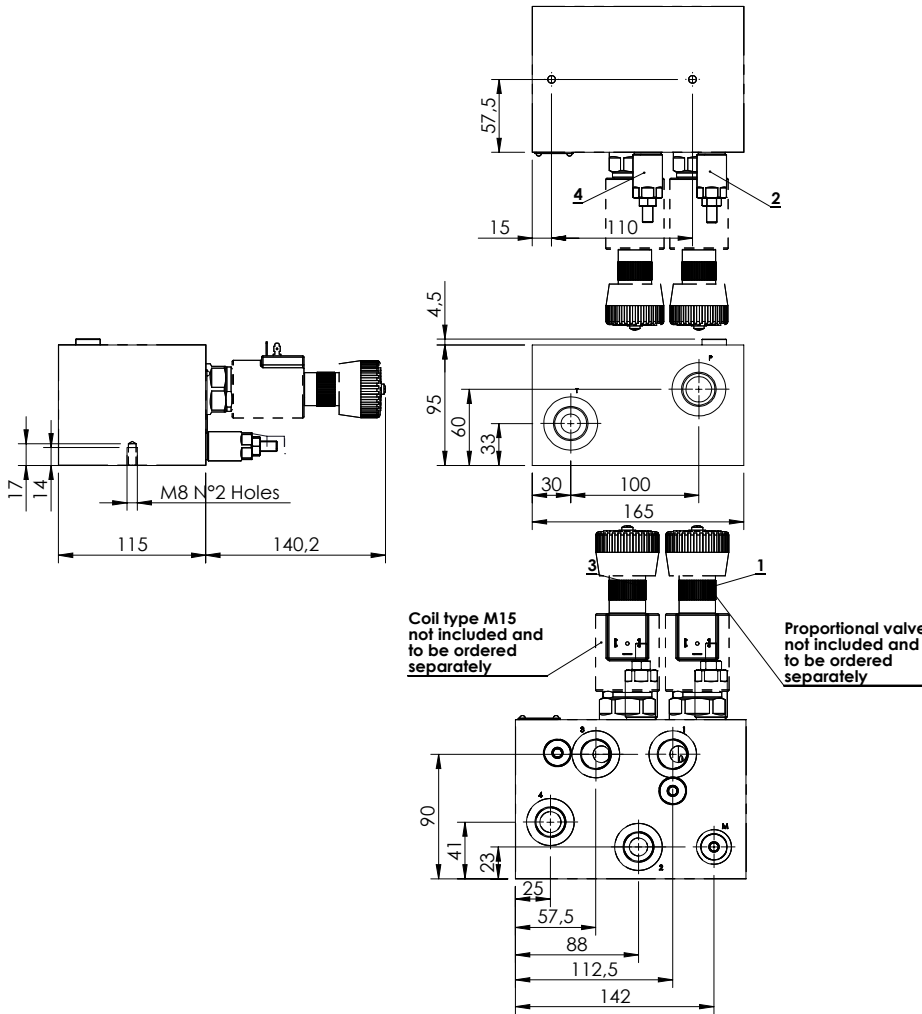
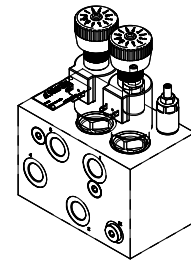

SPECIFICATIONS

Max. operating pressure:	250 bar
Rated flow:	140 l/min
Max regulated flow:	0 - 80 l/min
Manifold:	Aluminium
Weight:	4,4 kg
Coil type:	M15
Cavity type:	SAE-16-3N

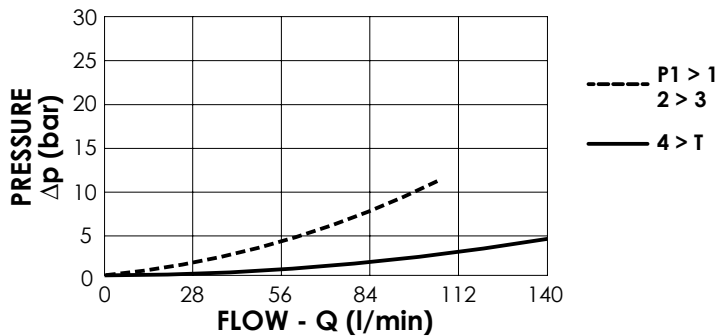

SEALING CAP:

Ordering code:
AT000020

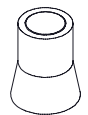

NOTES

- See chapter 18.00.000 for coils.
- See chapter 16.00.000 for proportional valve info.

ORDERING CODES

Quick code	Description	Main ports size	Standard setting (bar, Q=5 l/min)	Adjust. range (bar)	Pressure increase (bar/turn)
BF000020	BNFN-140-LPNR-02-M26-N250	1,2,3,4: M22x1,5 P,T: M27x2 M: M14x1,5	②:200 ④:100	②:50-210 ④:30-100	②:42 ④:20

SALT SPRAYER VALVE

BNFN-140-LPNR

PROPORTIONAL VALVE

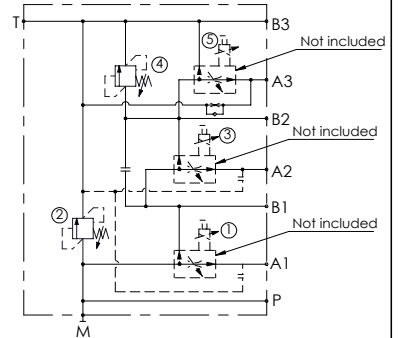
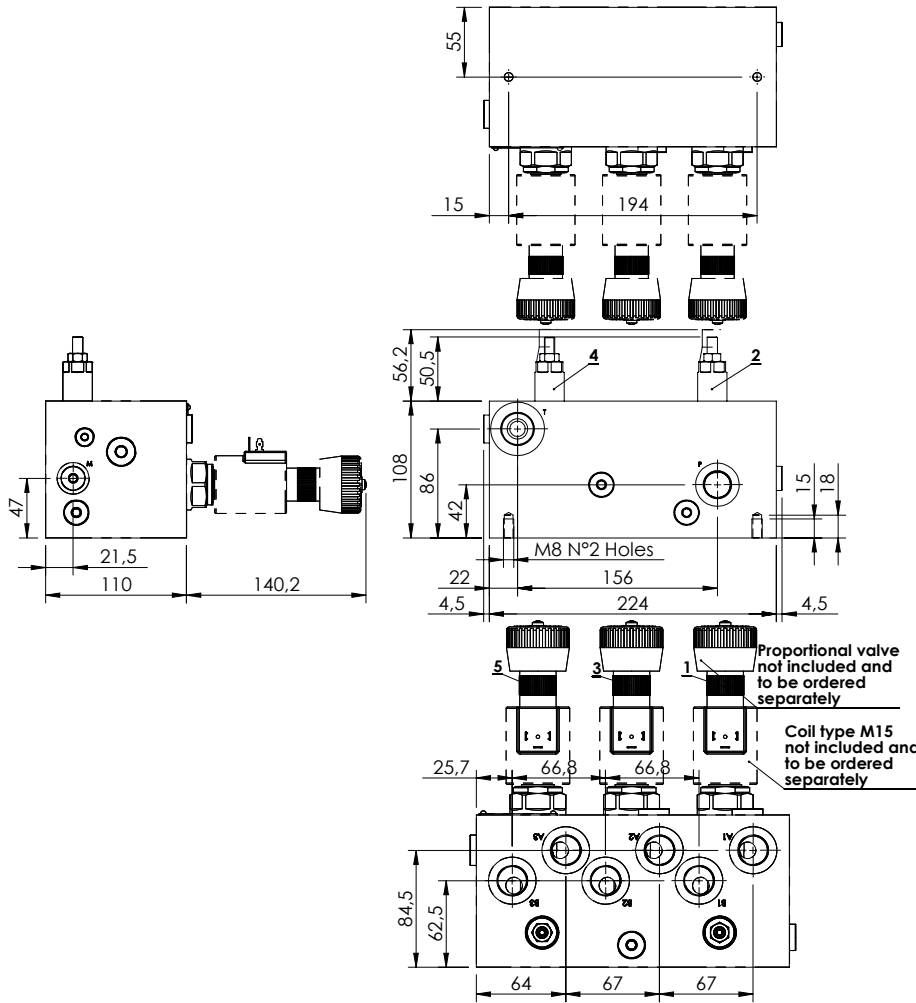
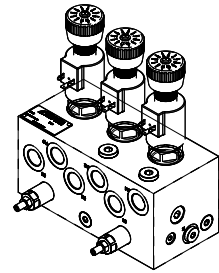

SPECIFICATIONS

Max. operating pressure:	250 bar
Rated flow:	140 l/min
Max regulated flow:	0 - 80 l/min
Manifold:	Aluminium
Weight:	6,4 kg
Coil type:	M15
Cavity type:	SAE-16-3N

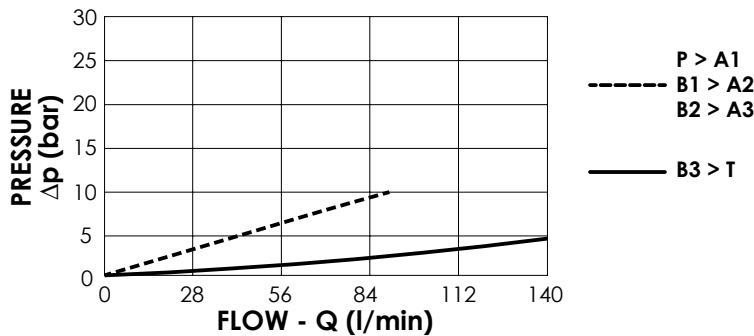

SEALING CAP:

Ordering code:
AT000020

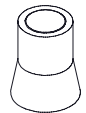

NOTES

-See chapter 18.00.000 for coils.
-See chapter 16.00.000 for proportional valve info.

ORDERING CODES

Quick code	Description	Main ports size	Standard setting (bar, Q=5 l/min)	Adjust. range (bar)	Pressure increase (bar/turn)
BF000019	BNFN-140-LPNR-03-M26-N250	A,B,P: M22x1,5 T: M26x1,5 M: M14x1,5	②:200 ④:100	②:50-210 ④:30-100	②:42 ④:20

SALT SPRAYER VALVE

EBLE-040-CCSM

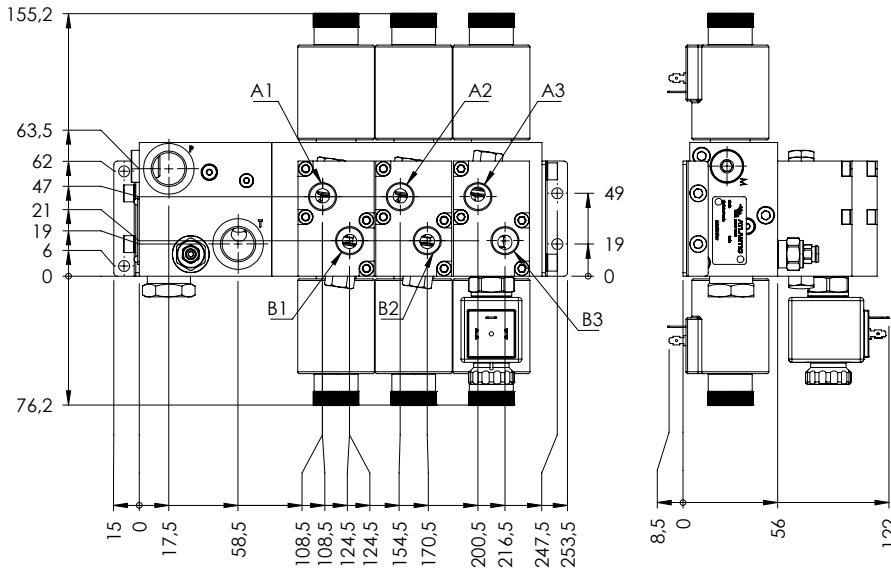
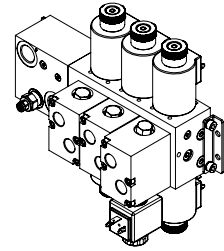

SPECIFICATIONS

Max. operating pressure:	210 bar
Rated flow:	40 l/min
Manifold:	Cast-iron
Weight:	11,8 kg

NOTES

For more informations see the chapter 19.00.000

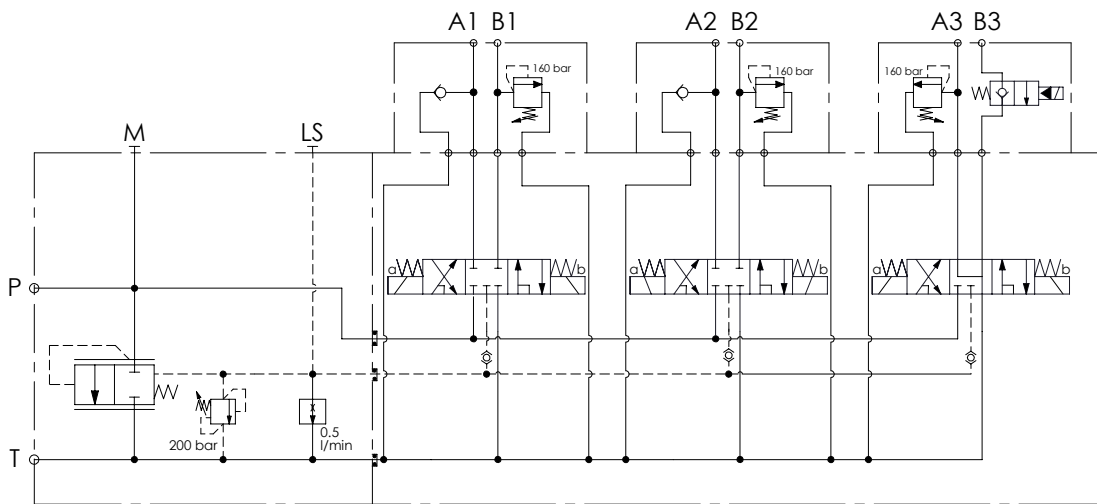

ORDERING CODES

Quick code	Description	Main ports size:	General relief setting: (bar)	Voltage: (V)	Coil type:
EB000041	EBLE-040-CCSM-MX-G12-BHRN	A,B: G3/8" P,T: G1/2" M: G1/4"	200	DIN 43650	24

SALT SPRAYER VALVE

EBLE-040-CCLM

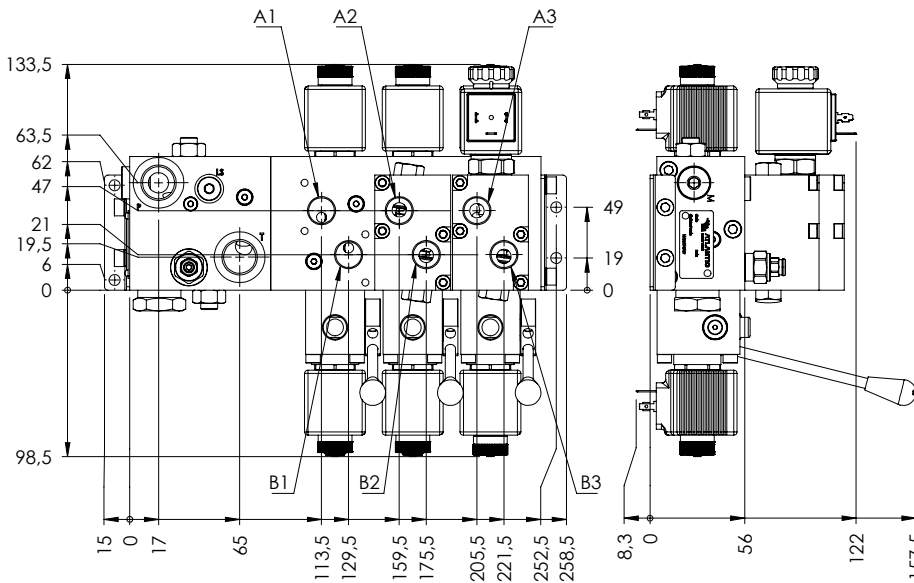
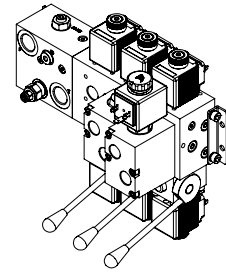

SPECIFICATIONS

Max. operating pressure:	210 bar
Rated flow:	40 l/min
Manifold:	Cast-iron
Weight:	10,6 kg

NOTES

For more informations see the chapter 19.00.000

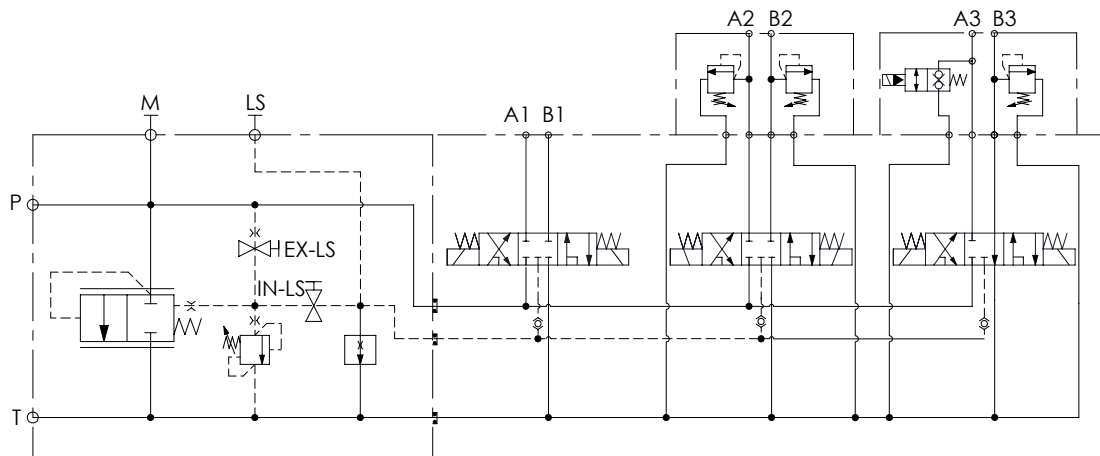

ORDERING CODES

Quick code	Description	Main ports size:	General relief setting: (bar)	Voltage: (V)	Coil type:
EB000042	EBLE-060-CCLM-MX-G12-BHRN	A,B: G3/8" P,T: G1/2" M: G1/4" LS: G1/8"	200	DIN 43650	24



1800-OILSOL
1800-645765

<https://oilsolutions.com.au/>

sales@oilsolutions.com.au

SECTION 20. 5

APPLICATIONS - GARBAGE COMPACTORS



Hydraulic scheme	Valve description	Valve type	Rated flow (l/min)	Max. pressure (bar)	Installation	Main port size or cavity type	Page
	MTLN-030-TLSL	-	30	210	In line	G 1/2"	20.05.010
	MDAF-080-BRNR	-	80	210	In line	G 1/2"	20.05.020
	MRDN-100-ZLNP	-	100	350	In line	G 3/4"	20.05.030
	BNND-100-NLBCU	-	150	350	In line	G 3/4"	20.05.040

GARBAGE COMPACTORS

MTLN-030-TLSL

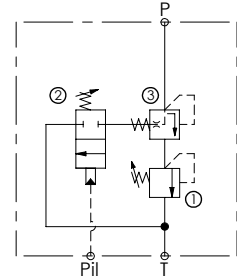
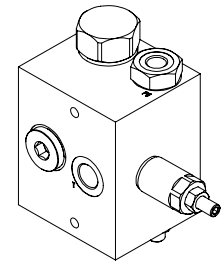
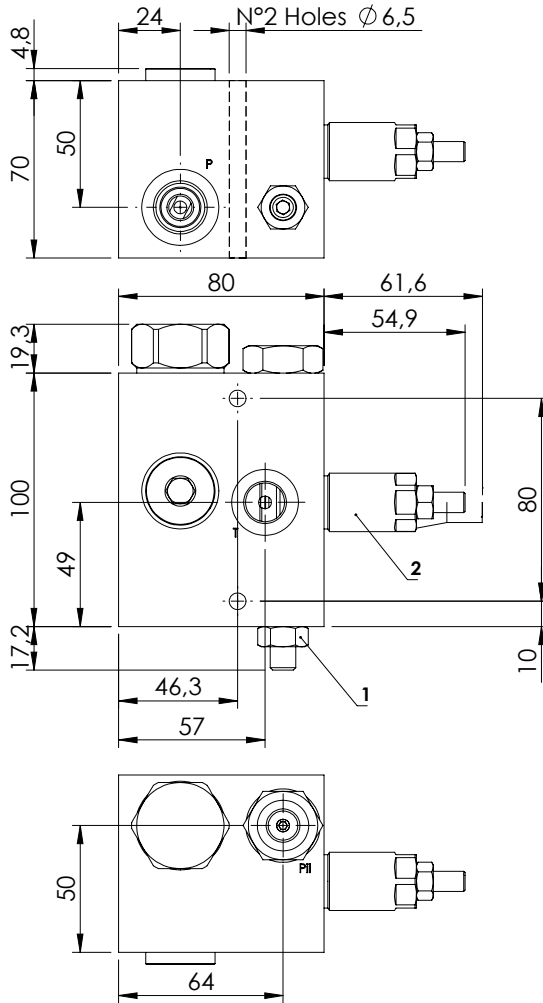

SPECIFICATIONS

Max. operating pressure:	210 bar
Rated flow:	30 l/min
Manifold:	Aluminium
Weight:	1,9 kg

SEALING CAP

Ordering code:
AT000020

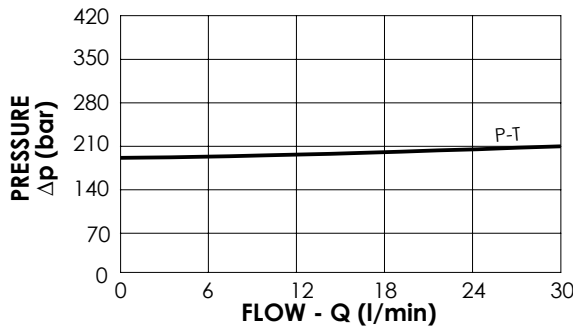
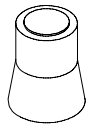

NOTES

ORDERING CODES

Quick code	Description	Main ports size	Standard setting (bar, Q=5 l/min)	Adjust. range (bar)	Pressure increase (bar/turn)
MT000008	MTLN-030-TLSL-NP-G12-N180	P, T: G 1/2" Pil: G 1/4"	①: 180 ②: 40	①: 40-200 ②: 10-50	①: 49 ②: 10

GARBAGE COMPACTORS

MDAF-080-BRNR

REGENERATIVE FUNCTION

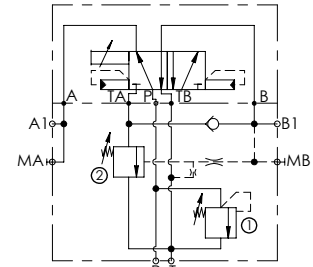
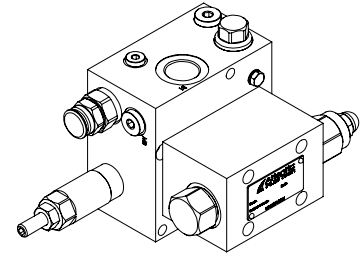

SPECIFICATIONS

Max. operating pressure:	210 bar
Rated flow:	80 l/min
Manifold:	Aluminium
Weight:	5,99 kg

SEALING CAP

Ordering code:
AT00021
(Valve n.1)

PT000243
(Valve n.2)

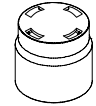
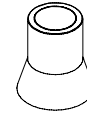

NOTES

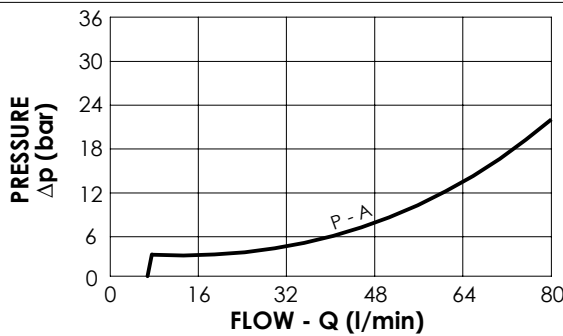
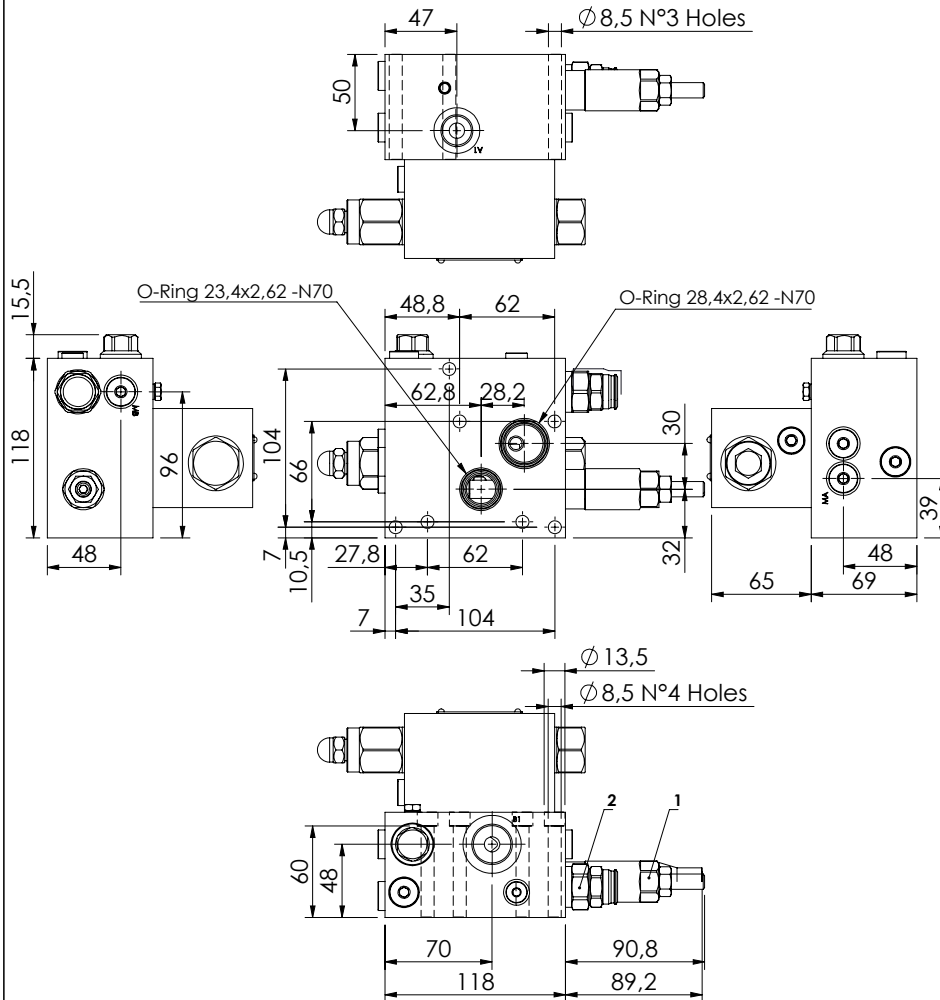

ORDERING CODES

Quick code	Description	Main ports size	Standard setting (bar, Q=5 l/min)	Adjust. range (bar)	Pressure increase (bar/turn)
MD000023	MDAF-080-BRNR-NP-N10-N210	P,A1:G1/2" T,B1:G3/4" MA,MB:G 1/4"	① 180 ② 130	① 100-350 ② 70-140	① 42 ② -

GARBAGE COMPACTORS

MRDN-150-ZLNP

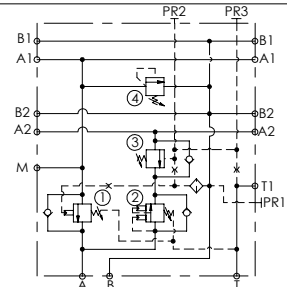
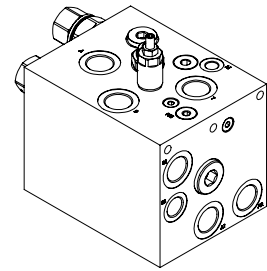
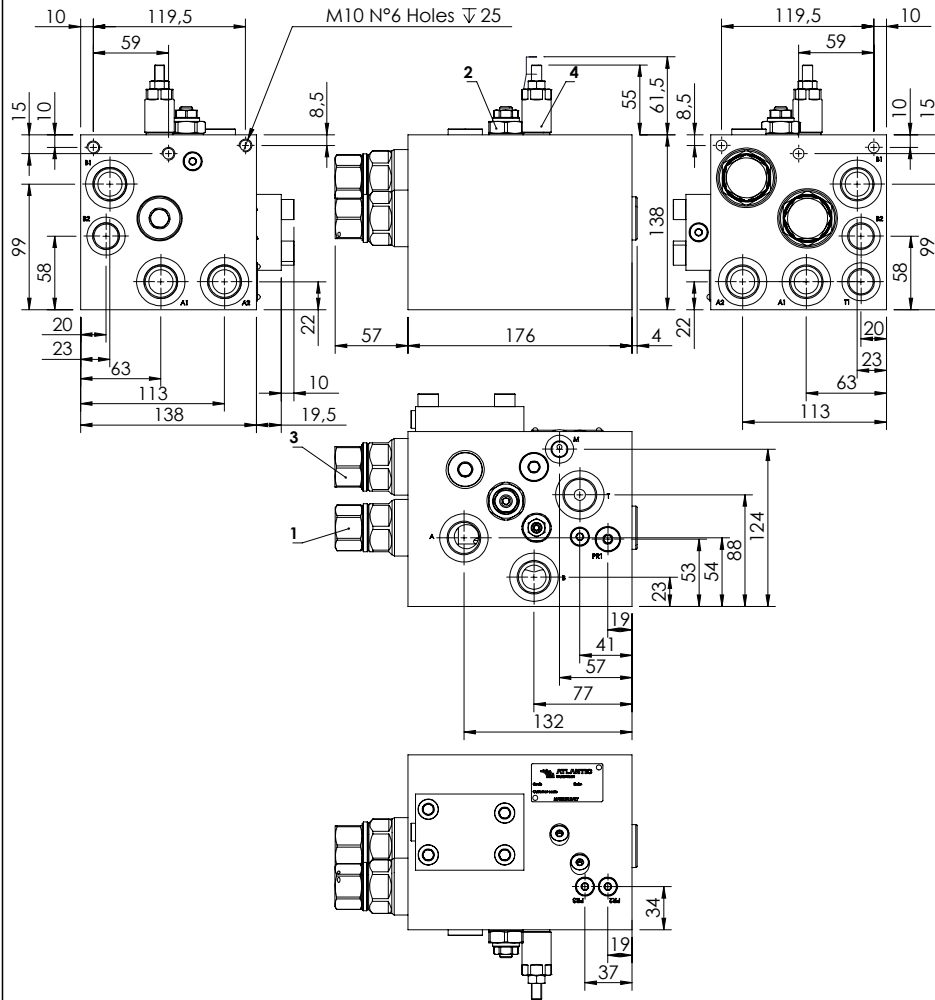

SPECIFICATIONS

Max. operating pressure:	350 bar
Rated flow:	150 l/min
Manifold:	Aluminium
Weight:	10,18 kg

SEALING CAP

Ordering code:
AT000020

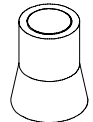

NOTES

ORDERING CODES

Quick code	Description	Pilot ratio	Main ports size	Standard setting (bar, Q=5 l/min)	Adjustment range (bar)	Pressure increase (bar/turn)
MB000700	MRDN-150-ZLNP-06-G34-N350	6:1	A, A1, A2, B, B1, T: G3/4" B2, T1: G1/2" T2, M1, T3: G1/4"	① 300 ③ 350 ② 175 ④ 280	① 100-350 ③ 60-210 ② 140-350 ④ 100-350	① 105 ③ 62 ② 70,5 ④ 91

GARBAGE COMPACTORS

BNND-150-NLBCU

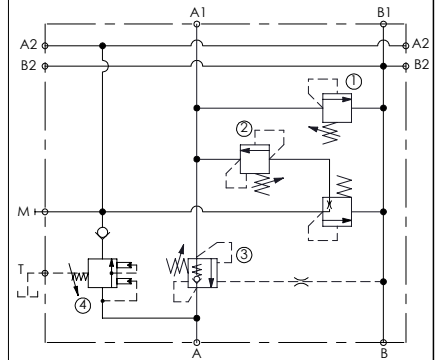
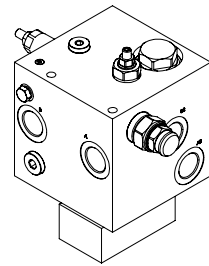

SPECIFICATIONS

Max. operating pressure:	350 bar
Rated flow:	150 l/min
Manifold:	Aluminium
Weight:	3,2 kg

SEALING CAP

Ordering code:

AT000020
Relief valve



ST000012
Counterbalance valve

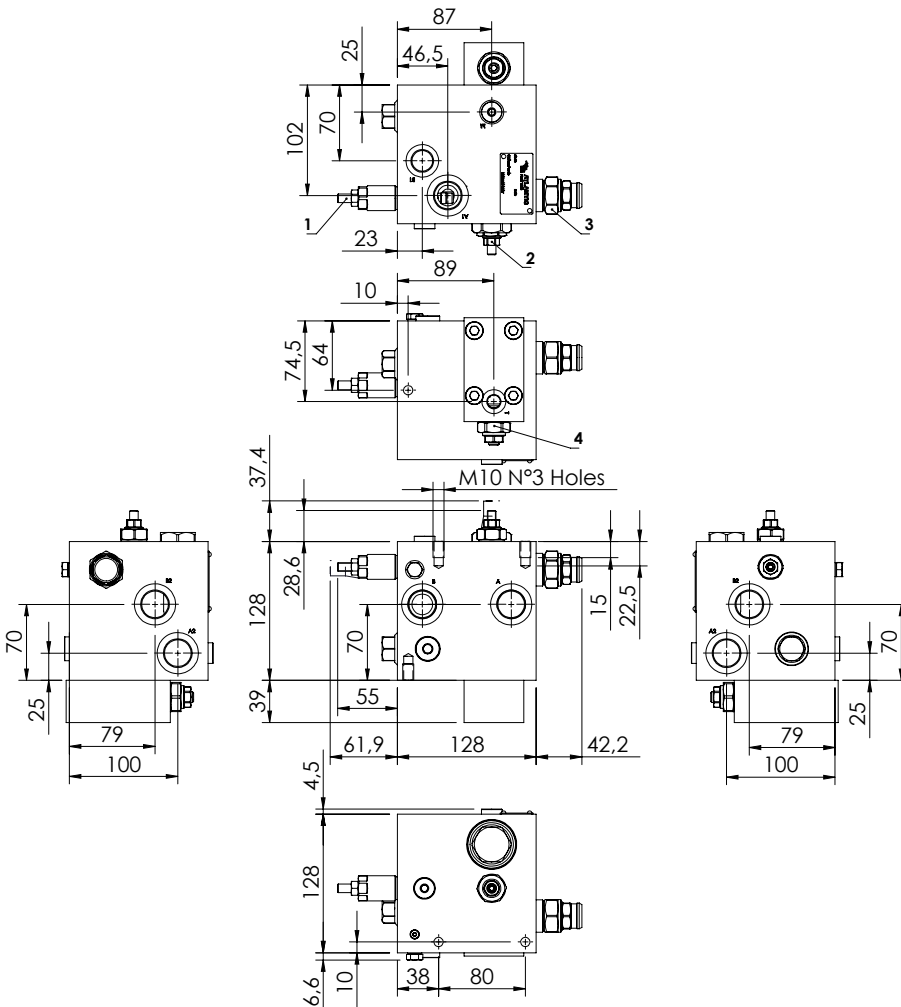

ORDERING CODES

Quick code	Description	Main ports size	Standard setting (bar, Q=5 l/min)	Adjustment range (bar)	Pressure increase (bar/turn)
BD000131	BNND-150-NLBCU-08-G34-N350	A,A1,A2,B,B2: G3/4" B1: G1/2" M,T: G1/4"	① 280 ③ 230 ② 50 ④ 175	① 100-350 ③ 60-210 ② 90-210 ④ 140-350	① 91 ③ 50 ② 87 ④ 70,5



1800-OILSOL
1800-645765

<https://oilsolutions.com.au/>

sales@oilsolutions.com.au

SECTION 20. 6

APPLICATIONS - HOOK LOADERS



Hydraulic scheme	Valve description	Valve type	Rated flow (l/min)	Max. pressure (bar)	Installation	Main port size or cavity type	Page
	MBDN-150-ZABE	Double acting with electric by-pass	150	350	In line	G 3/4"	20.06.010
	MBPN-150-ZLNR	Regenerative with electric by-pass	150	350	In line	G 3/4"	20.06.020
	MRSN-150-ALBE	Regenerative with electric by-pass	150	350	In line	G 3/4"	20.06.030
	MRLN-150-ZABE	Regenerative with electric by-pass	150	350	In line	G 3/4"	20.06.040

HOOK LOADERS

MBDN-150-ZABE

**DOUBLE ACTING
WITH ELECTRIC BY-PASS**

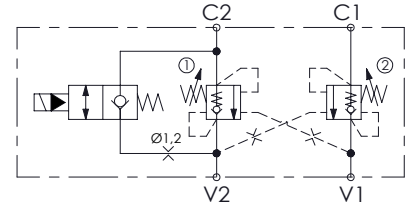
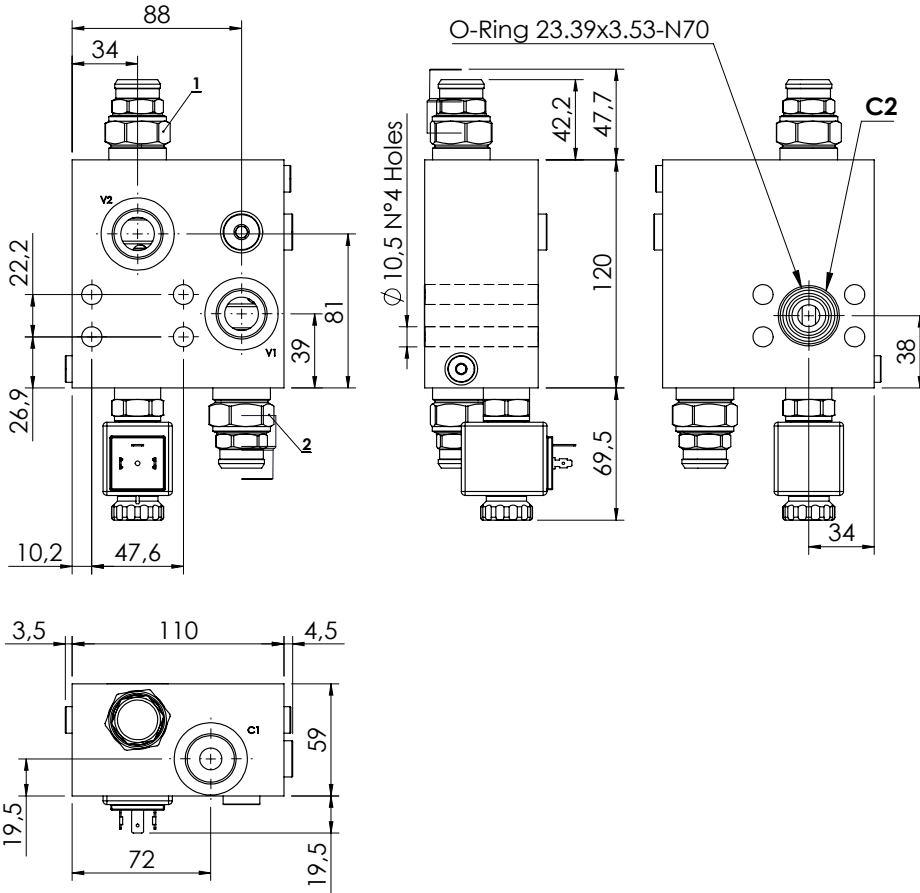
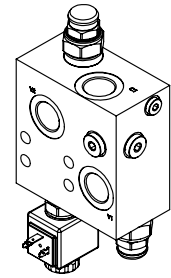

SPECIFICATIONS

Max. operating pressure:	350 bar
Rated flow:	150 l/min
Manifold:	Steel
Weight:	2,75 kg
Coil:	M7 Type
Voltage - Class:	26V - H
Connector:	DIN 43650

SEALING CAP

Ordering code:
ST000012



NOTES

Setting: at least 1.3 times the load induced pressure

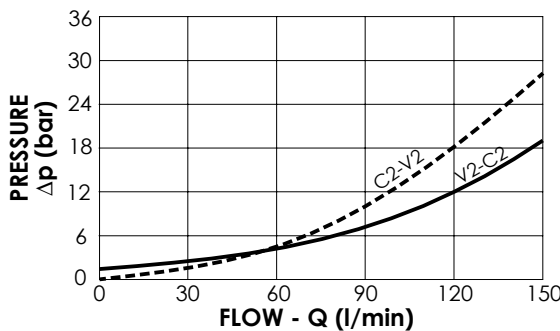

ORDERING CODES

Quick code	Description	Pilot ratio	Main ports size	Standard setting (bar, Q=5 l/min)	Adjust. range (bar)	Pressure increase (bar/turn)
MB000915	MBDN-150-ZABE-04-G34-N350	4:1	V1,V2,C1: G3/4" C2: 3/4 SAE 3000	350	100-350	104

HOOK LOADERS

MBPN-150-ZLNR

REGENERATIVE
WITH ELECTRIC BY-PASS

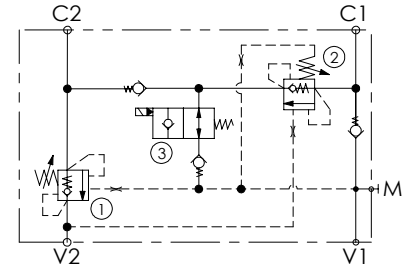
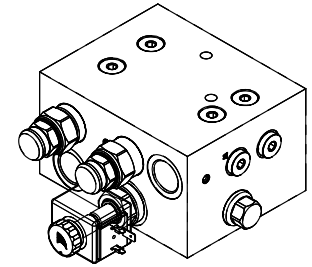
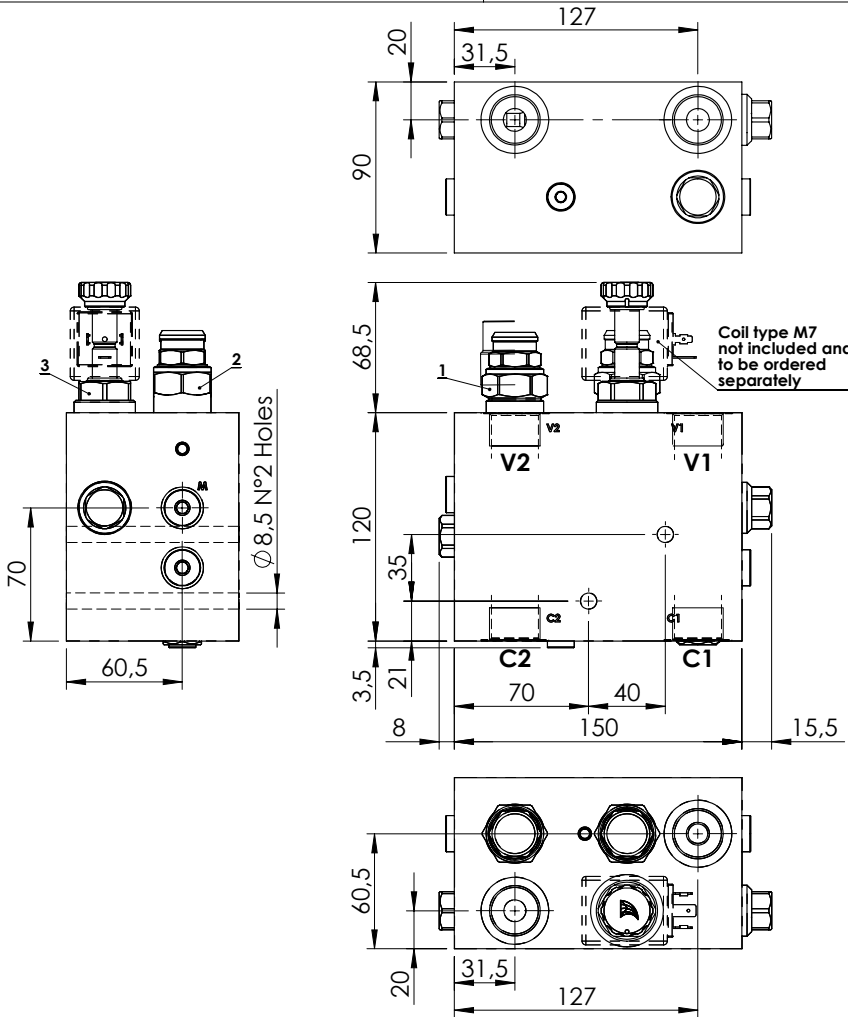

SPECIFICATIONS

Max. operating pressure:	350 bar
Rated flow:	150 l/min
Manifold:	Aluminium
Weight:	4,92 kg
Coil type:	M7

SEALING CAP

Ordering code:
ST000012

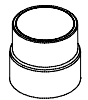

NOTES

Setting: at least 1.3 times the load induced pressure

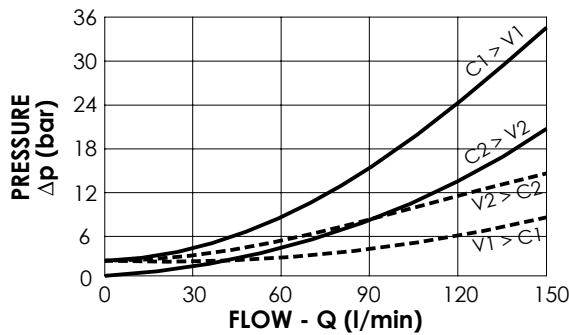

ORDERING CODES

Quick code	Description	Pilot ratio	Main ports size	Standard setting (bar, Q=5 l/min)	Adjust. range (bar)	Pressure increase (bar/turn)
MB000919	MBPN-150-ZLNR-04-G34-N210	4:1	C1,C2,V1,V2: G3/4" M: G1/4"	350	100-350	104

HOOK LOADERS

MRSN-150-ALBE

REGENERATIVE
WITH ELECTRIC BY-PASS

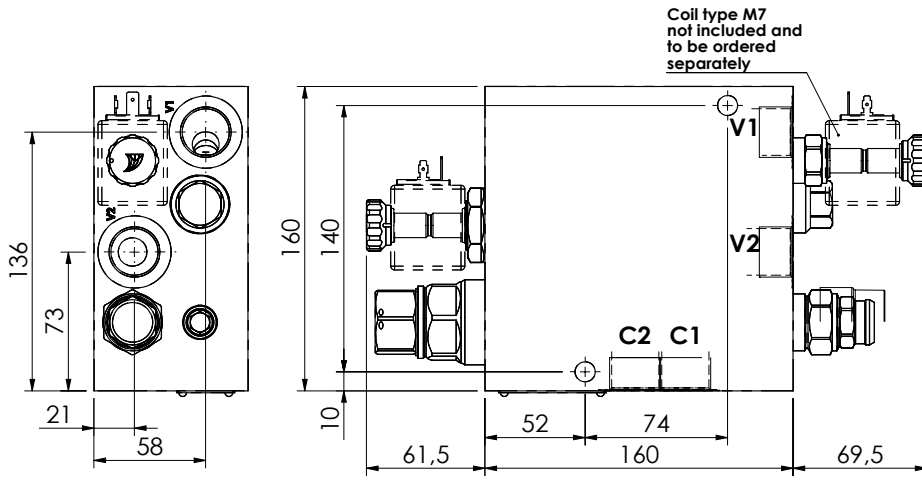
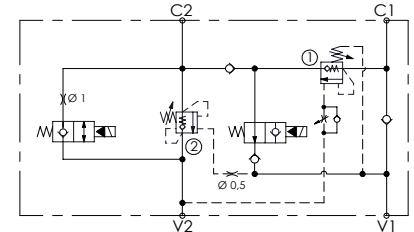
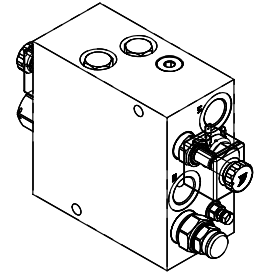
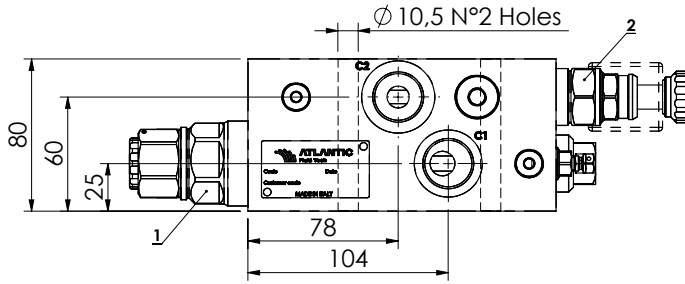

SPECIFICATIONS

Max. operating pressure:	350 bar
Rated flow:	150 l/min
Manifold:	Steel
Weight:	14,95 kg
Coil type:	M7

SEALING CAP

Ordering code:
ST00012

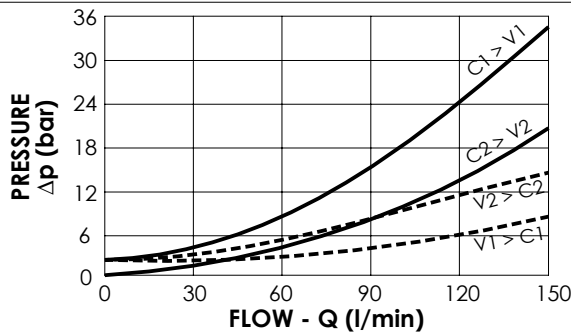

NOTES

Setting: at least 1.3 times the load induced pressure

ORDERING CODES

Quick code	Description	Pilot ratio	Main ports size	Standard setting (bar, Q=5 l/min)	Adjust. range (bar)	Pressure increase (bar/turn)
MB000920	MRSN-150-ALBE-04-G34-N350	4:1	V1, V2: G3/4" C1, C2: G3/4"	350	100-350	104

HOOK LOADERS

MRLN-150-ZABE

REGENERATIVE
WITH ELECTRIC BY-PASS

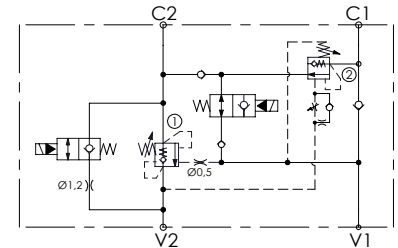
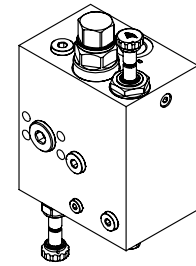
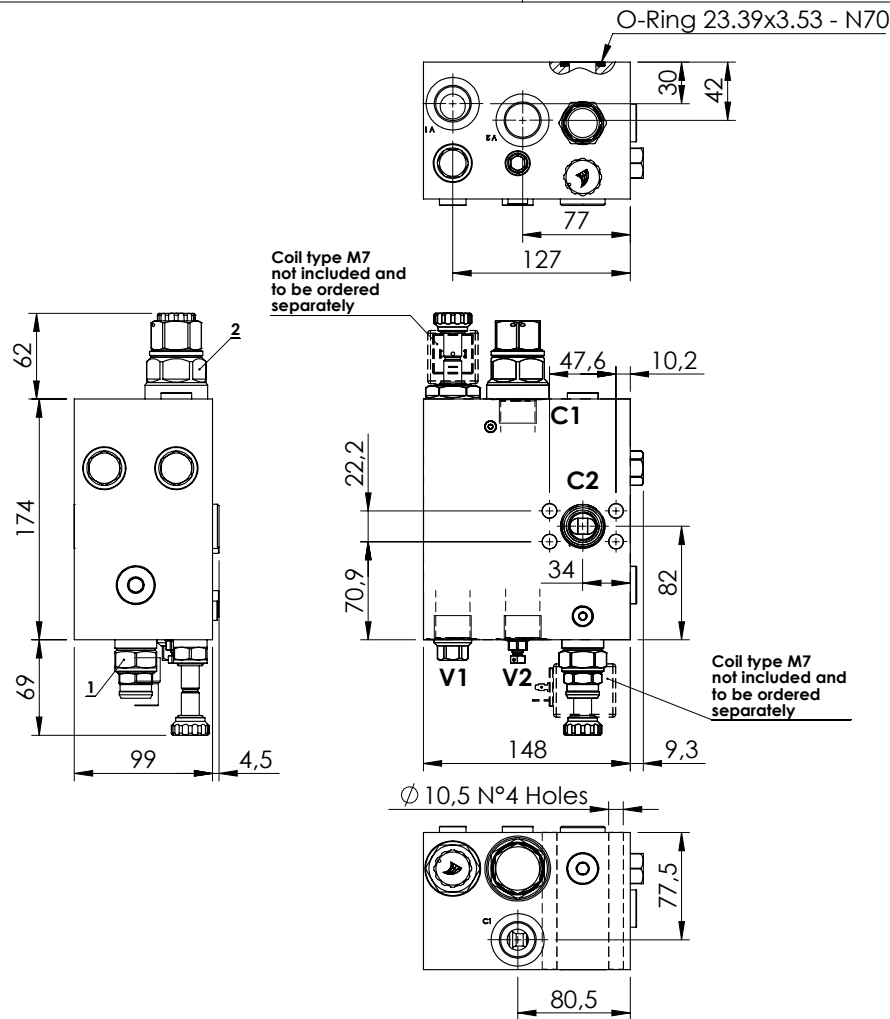

SPECIFICATIONS

Max. operating pressure:	350 bar
Rated flow:	150 l/min
Manifold:	Aluminium
Weight:	7,59 kg
Coil type:	M7

SEALING CAP

Ordering code:
ST000012



NOTES

Setting: at least 1.3 times the load induced pressure

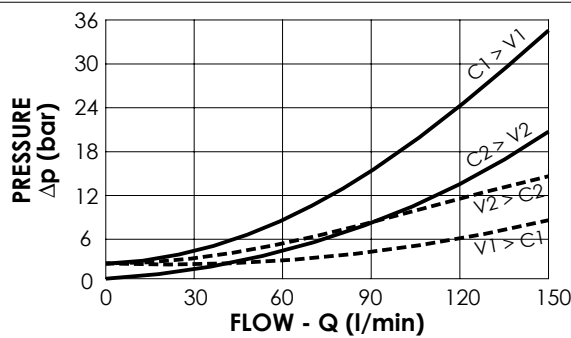

ORDERING CODES

Quick code	Description	Pilot ratio	Main ports size	Standard setting (bar, Q=5 l/min)	Adjust. range (bar)	Pressure increase (bar/turn)
MB000119	MRLN-150-ZABE-04-G34-N350	4:1	V2,C2,C1: G3/4" C2: Ø22	350	100-350	104



ATLANTIC
Fluid Tech

SECTION 21

Coils and
Connectors



1800-OILSOL
1800-645765

<https://oilsolutions.com.au/>

sales@oilsolutions.com.au

SECTION 21



COILS AND CONNECTORS

Description	Type	Heat insulation class	Connector	Page
Coil M7 HS	M7 - For solenoid operated cartridge valve	H - 180°C	EN 175301-803 - DIN 43650 - ISO 4400	21.00.010
Coil M7 HS	M7 - For solenoid operated cartridge valve - RAC	H - 180°C	EN 175301-803 - DIN 43650 - ISO 4400	21.00.020
Coil M7 AJ	M7 - For solenoid operated cartridge valve	H - 180°C	Amp Junior	21.00.030
Coil M7 DT	M7 - For solenoid operated cartridge valve	H - 180°C	Deutsch - DT04-2P-L	21.00.040
Coil M7 DT	M7 - For solenoid operated cartridge valve	H - 180°C	Deutsch - DT04-2P-V	21.00.050
Coil M14 HS	M14 - For solenoid operated cartridge valve	H - 180°C	EN 175301-803 - DIN 43650 - ISO 4400	21.00.060
Coil M14 DT	M14 - For solenoid operated cartridge valve	H - 180°C	Deutsch - DT04-2P-V	21.00.070
Coil M15 HS	M15 - For proportional solenoid operated cartridge valve	H - 180°C	EN 175301-803 - DIN 43650 - ISO 4400	21.00.080
Coil M8 HS	M8 - For Ø19 tube diverter valve	H - 180°C	EN 175301-803 - DIN 43650 - ISO 4400	21.00.090
Coil M11 HS	M11 - For Ø22 tube diverter valve	H - 180°C	EN 175301-803 - DIN 43650 - ISO 4400	21.00.100
DIN Connector	IP67 - Standard / with VDR / with rectifier	-	EN 175301-803 - DIN 43650 - ISO 4400	21.00.110

COIL

COIL SERIES M7

DIN 43650 - ISO 4400
CLASS H

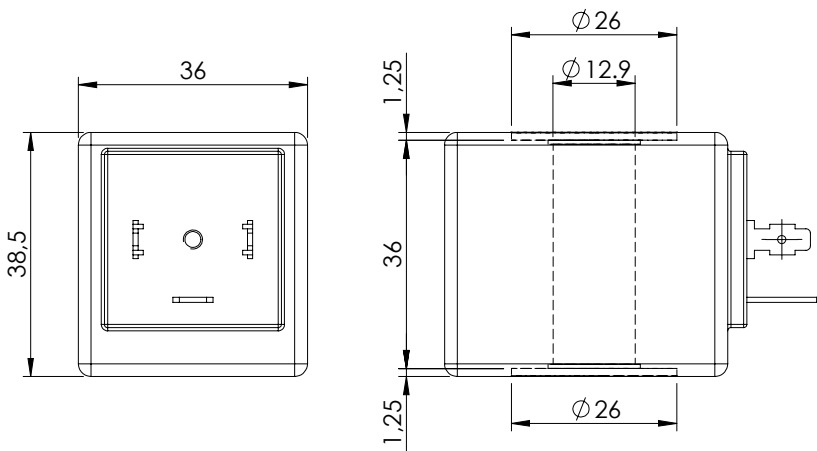
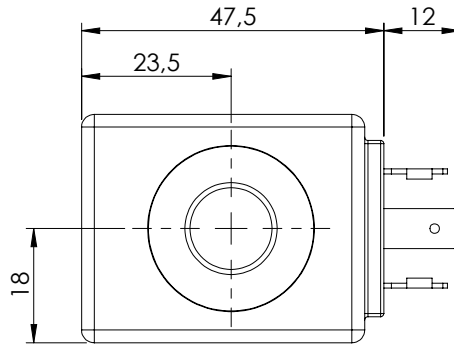
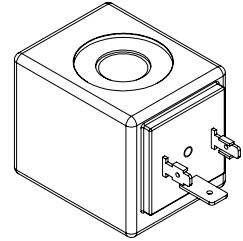

SPECIFICATIONS

Heat insulation: Class H (180°C)

Ambient temperature: See graph

Inlet voltage: See graph

Insulation class: IP65 with all seals properly mounted

Weight: 0,217 kg

NOTES

ED 100% in the functional range area.

Do not exceed the functional range.

For applications with working range close to graph limit please contact AFT sales network.

The seals supplied with the valve must be properly mounted.

Please refer to catalogue technical chapter for more info.

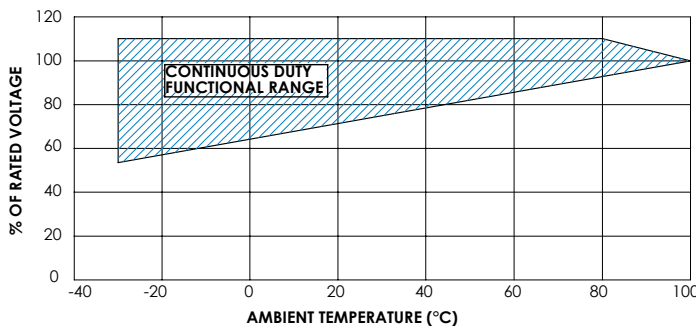

ORDERING CODES

Quick code	Description	Connection type	Voltage (V)	Resistance (Ω) $\pm 7\%$	Power (w)	Current (A)
AB000002	Coil M7 HS 12V CLASS H	DIN 43650-ISO 4400	12 DC	7,2	20	1,67
AB000018	Coil M7 HS 14V CLASS H	DIN 43650-ISO 4400	14 DC	9,8	20	1,43
AB000003	Coil M7 HS 24V CLASS H	DIN 43650-ISO 4400	24 DC	28,8	20	0,83
AB000004	Coil M7 HS 26V CLASS H	DIN 43650-ISO 4400	26 DC	33,8	20	0,77
AB000043	Coil M7 HS 10.5V CLASS H	DIN 43650-ISO 4400	10.5 DC	5,5	20	1,90
AB000046	Coil M7 HS 48V CLASS H	DIN 43650-ISO 4400	48 DC	115,2	20	0,42

COIL

COIL SERIES M7

DIN 43650 - ISO 4400
RAC CLASS H

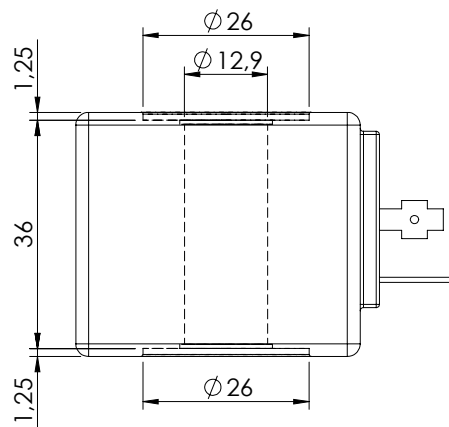
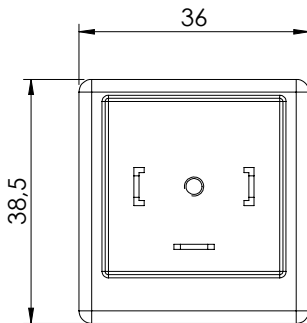
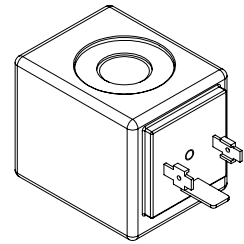
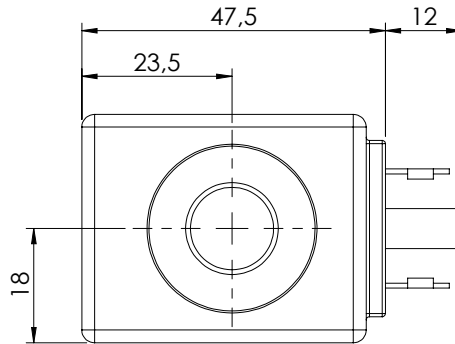

SPECIFICATIONS

Heat insulation class H	180°C
Ambient temperature	-30 + 60°C
Inlet voltage	±10% tol.
Insulation class IP69K with all seals properly mounted	
Weight:	0,18 kg

ED 100% in the functional range area.
Do not exceed the functional range.

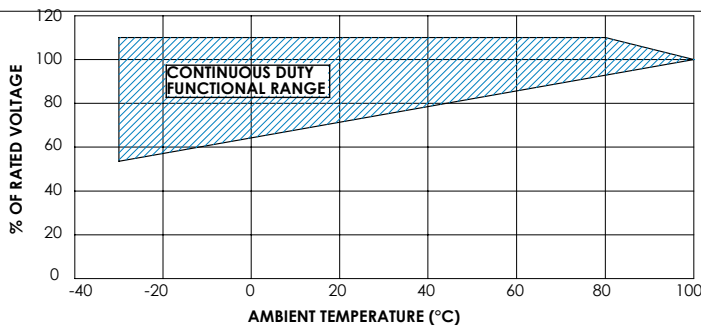

NOTES: Specifications with working range close to graph limit please contact AFT sales network.

The seals supplied with the valve must be properly mounted.

Please refer to catalogue technical chapter for more info.

ORDERING CODES

Quick code	Description	Connector type	Voltage (V)	Resistance (Ω) ±7%	Power (w)	Current (A)
AB000011	Coil M7 HS 12V CLASS H	DIN 43650-ISO 4400	24 RAC	23,1	20	0,9
AB000012	Coil M7 HS 110V RAC Class H	DIN 43650-ISO 4400	110 RAC	605	20	0,18
AB000007	Coil M7 HS 220V RAC Class H	DIN 43650-ISO 4400	220 RAC	2140	20	0,09

COIL

COIL SERIES M7

**AMP JUNIOR
CLASS H**

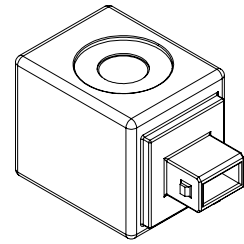
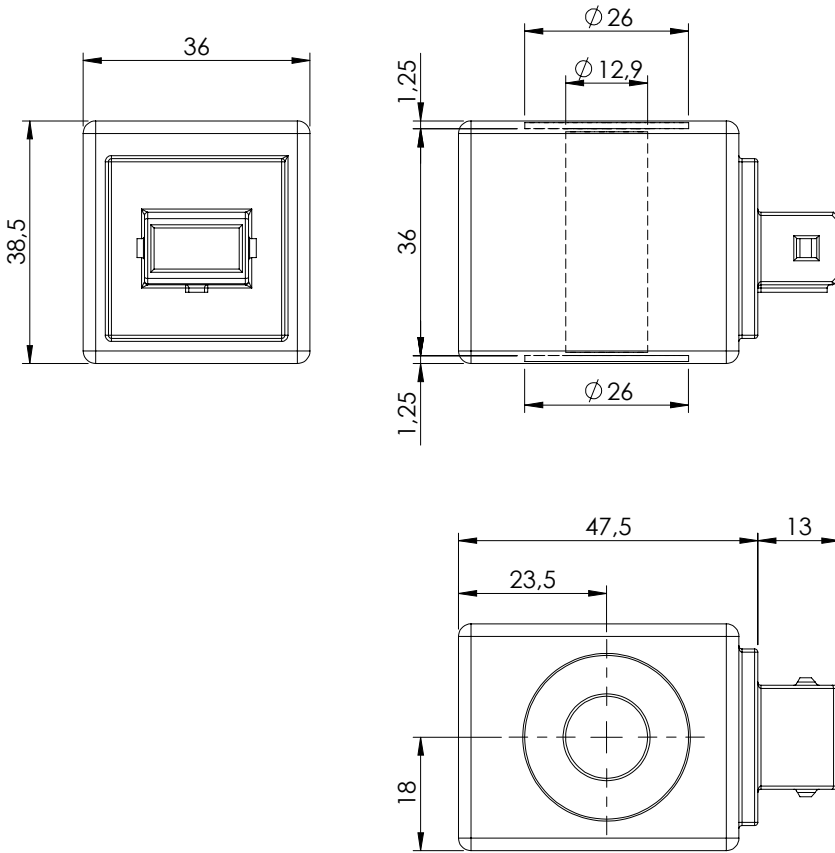

SPECIFICATIONS

Heat insulation class H	180°C
Ambient temperature	-30 + 60°C
Inlet voltage	±10% tol.
Insulation class IP69K with all seals properly mounted	
Weight:	0,18 kg

NOTES

ED 100% in the functional range area.
Do not exceed the functional range.

For applications with working range close to graph limit please contact AFT sales network.

The seals supplied with the valve must be properly mounted.

Please refer to catalogue technical chapter for more info.

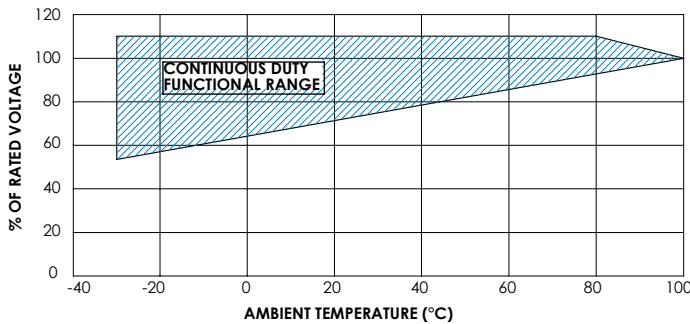

ORDERING CODES

Quick code	Description	Connector type	Voltage (V)	Resistance (Ω) ±7%	Power (w)	Current (A)
AB000005	Coil M7 AJ 12V CLASS H	AMP JUNIOR	12 DC	7,2	20	1,67
AB000014	Coil M7 AJ 24V CLASS H	AMP JUNIOR	24 DC	28,8	20	0,83
AB000010	Coil M7 AJ 26V CLASS H	AMP JUNIOR	26 DC	33,8	20	0,77

COIL

COIL SERIES M7

DEUTSCH DT04-2P-L
CLASS H

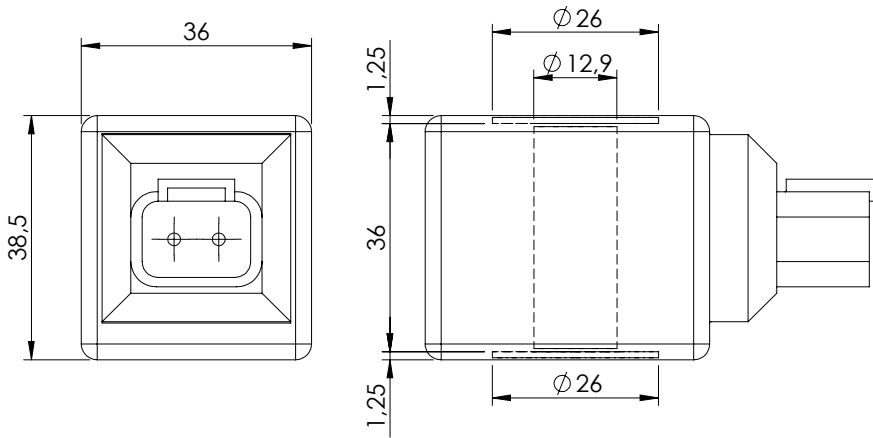
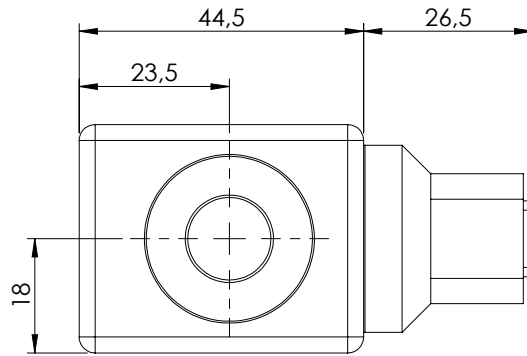
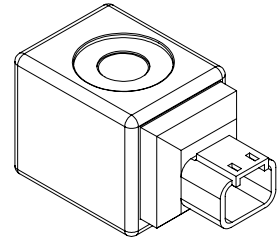

SPECIFICATIONS

Heat insulation class H	180°C
Ambient temperature	-30 + 60°C
Inlet voltage	±10% tol.
Insulation class IP69K with all seals properly mounted	
Weight:	0,18 kg

NOTES

- Equipped with bi-directional diode.
- ED 100% in the functional range area.
- Do not exceed the functional range.
- For applications with working range close to graph limit please contact AFT sales network.
- The seals supplied with the valve must be properly mounted.
- Please refer to catalogue technical chapter for more info.

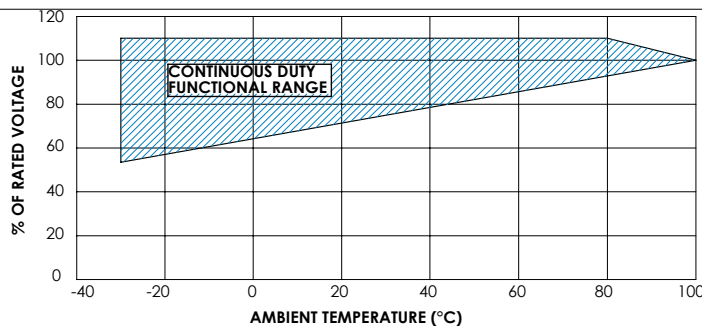

ORDERING CODES

Quick code	Description	Connector type	Voltage (V)	Resistance (Ω) ±7%	Power (w)	Current (A)
AB000001	Coil M7 DT 12V CLASS H	DT04-2P-L	12 DC	7,2	20	1,67
AB000008	Coil M7 DT 24V CLASS H	DT04-2P-L	24 DC	28,8	20	0,83

COIL

COIL SERIES M7

DEUTSCH DT04-2P-V
CLASS H

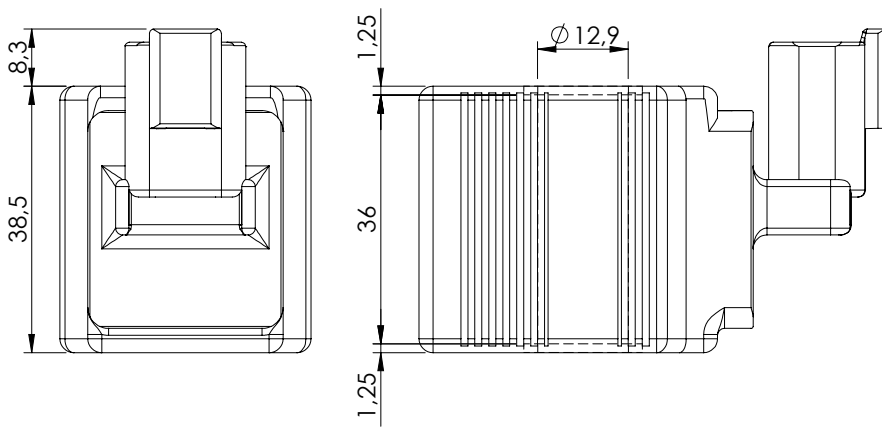
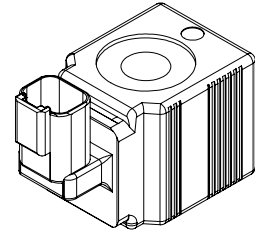
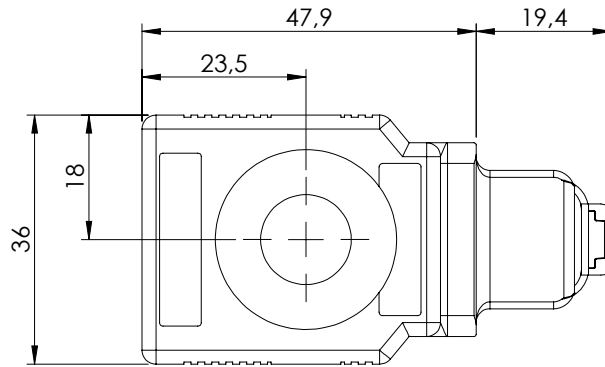

SPECIFICATIONS

Heat insulation class H	180°C
Ambient temperature	-30 + 60°C
Inlet voltage	±10% tol.
Insulation class IP69K with all seals properly mounted	
Weight:	0,18 kg

NOTES

- Equipped with bi-directional diode.
- ED 100% in the functional range area.
- Do not exceed the functional range.
- For applications with working range close to graph limit please contact AFT sales network.
- The seals supplied with the valve must be properly mounted.
- Please refer to catalogue technical chapter for more info.

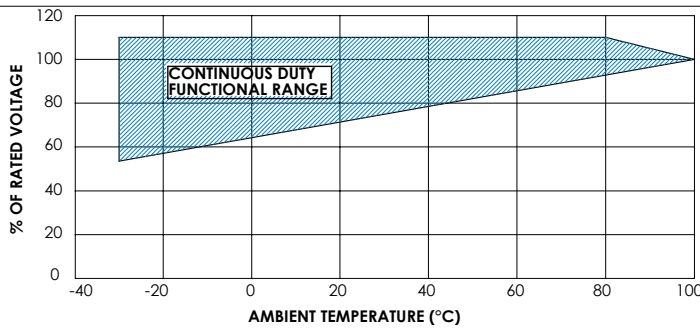

ORDERING CODES

Quick code	Description	Connector type	Voltage (V)	Resistance (Ω) ±7%	Power (w)	Current (A)
AB000022	Coil M7 DTV 12V CLASS H	DT04-2P-V	12 DC	7,2	20	1,67
AB000229	Coil M7 DTV 14V CLASS H	DT04-2P-V	14 DC	9,8	20	1,43
AB000023	Coil M7 DTV 24V CLASS H	DT04-2P-V	24 DC	28,8	20	0,83
AB000024	Coil M7 DTV 26V CLASS H	DT04-2P-V	26 DC	33,8	20	0,77
AB000230	Coil M7 DTV 28V CLASS H	DT04-2P-V	28 DC	39,4	20	0,71

COIL

COIL SERIES M14

DIN 43650 - ISO 4400
CLASS H

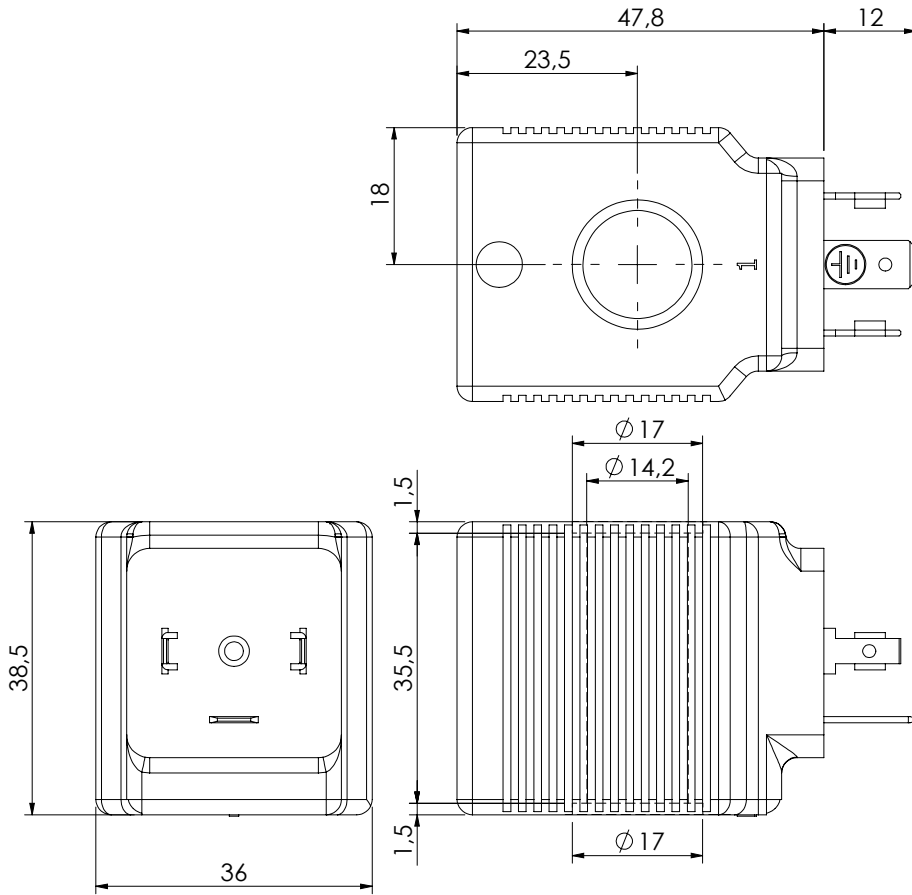
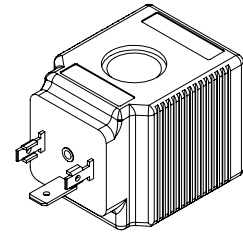

SPECIFICATIONS

Heat insulation class H	180°C
Ambient temperature	-30 + 60°C
Inlet voltage	±10% tol.
Insulation class IP69K with all seals properly mounted	
Weight:	0,18 kg

NOTES

ORDERING CODES

Quick code	Description	Connector type	Voltage (V)	Resistance (Ω) $\pm 7\%$	Power (w)	Current (A)
AB000143	Coil M14 HS 12V CLASS H	DIN 43650-ISO 4400	12 DC	5,53	26	2,17
AB000145	Coil M14 HS 13V CLASS H	DIN 43650-ISO 4400	13 DC	6,5	26	2,00
AB000144	Coil M14 HS 24V CLASS H	DIN 43650-ISO 4400	24 DC	22,15	26	1,08

COIL

COIL SERIES M14

DEUTSCH DT04-2P-V
CLASS H

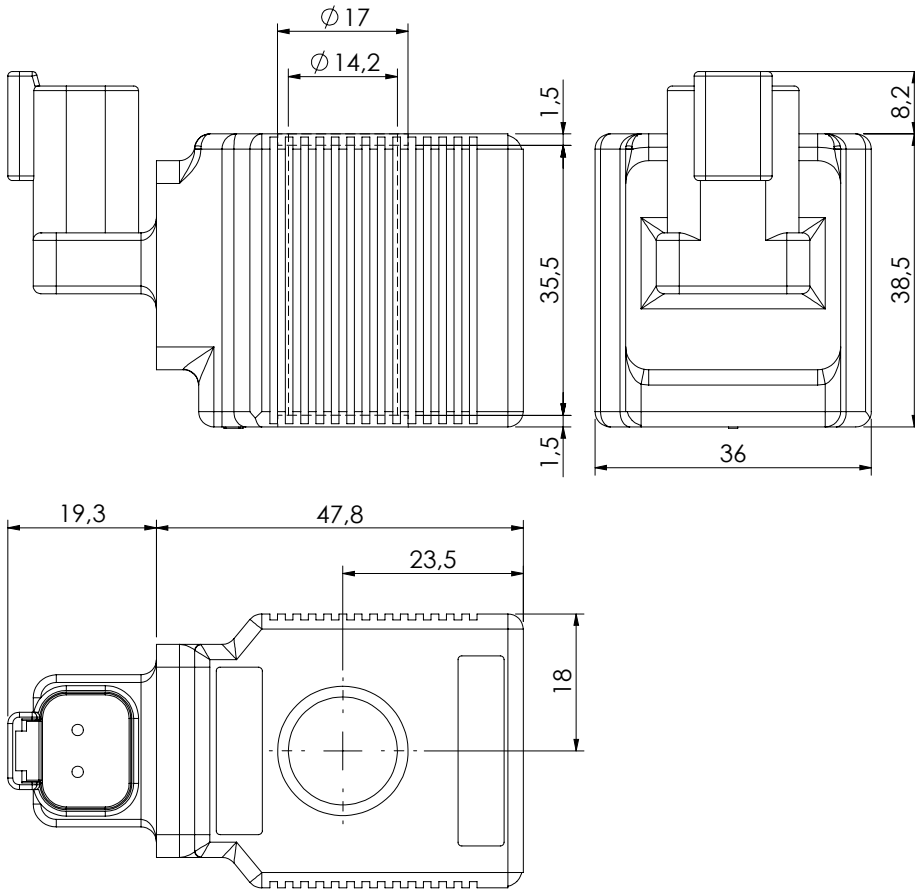
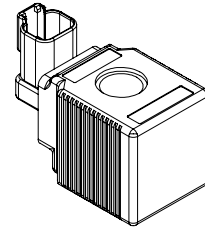

SPECIFICATIONS

Heat insulation class H	180°C
Ambient temperature	-30 + 60°C
Inlet voltage	±10% tol.
Insulation class IP69K with all seals properly mounted	
Weight:	0,18 kg

NOTES

With bi-directional diode

ORDERING CODES

Quick code	Description	Connector type	Voltage (V)	Resistance (Ω) $\pm 7\%$	Power (w)	Current (A)
AB000132	Coil M14 DTV 12V CLASS H	DT04-2P-V	12 DC	5,53	26	2,17
AB000133	Coil M14 DTV 24V CLASS H	DT04-2P-V	24 DC	22,15	26	1,08
AB000211	Coil M14 DTV 26V CLASS H	DT04-2P-V	26 DC	26	26	1

COIL

COIL SERIES M15

DIN 43650 - ISO 4400
CLASS H

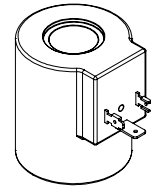
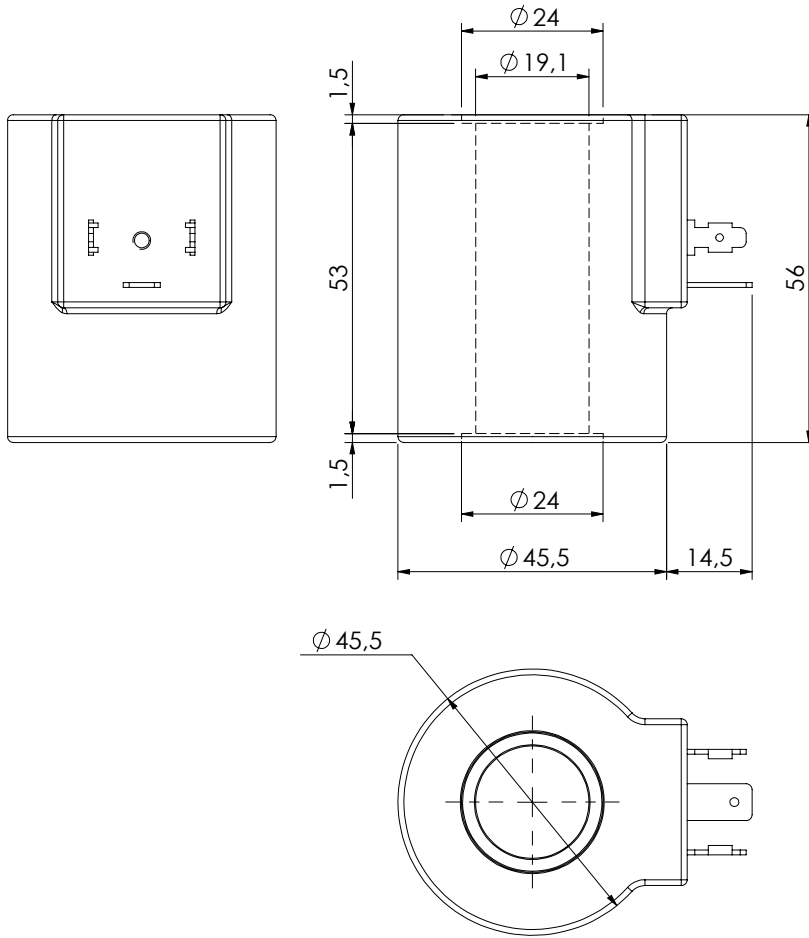

SPECIFICATIONS

Heat insulation class H	180°C
Ambient temperature	-30 + 60°C
Inlet voltage	±10% tol.
Insulation class IP69K with all seals properly mounted	
Weight:	0,18 kg

NOTES

ORDERING CODES

Quick code	Description	Connector type	Voltage (V)	Resistance (Ω) ±7%	Power (w)	Current (A)
AB000137	Coil M15 HS 12V CLASS H	DIN 43650-ISO 4400	12 DC	6.26	23	1.92
AB000138	Coil M15 HS 24V CLASS H	DIN 43650-ISO 4400	24 DC	25.05	23	0.96

COIL

COIL SERIES M8

DIN 43650 - ISO 4400
CLASS H

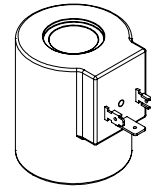
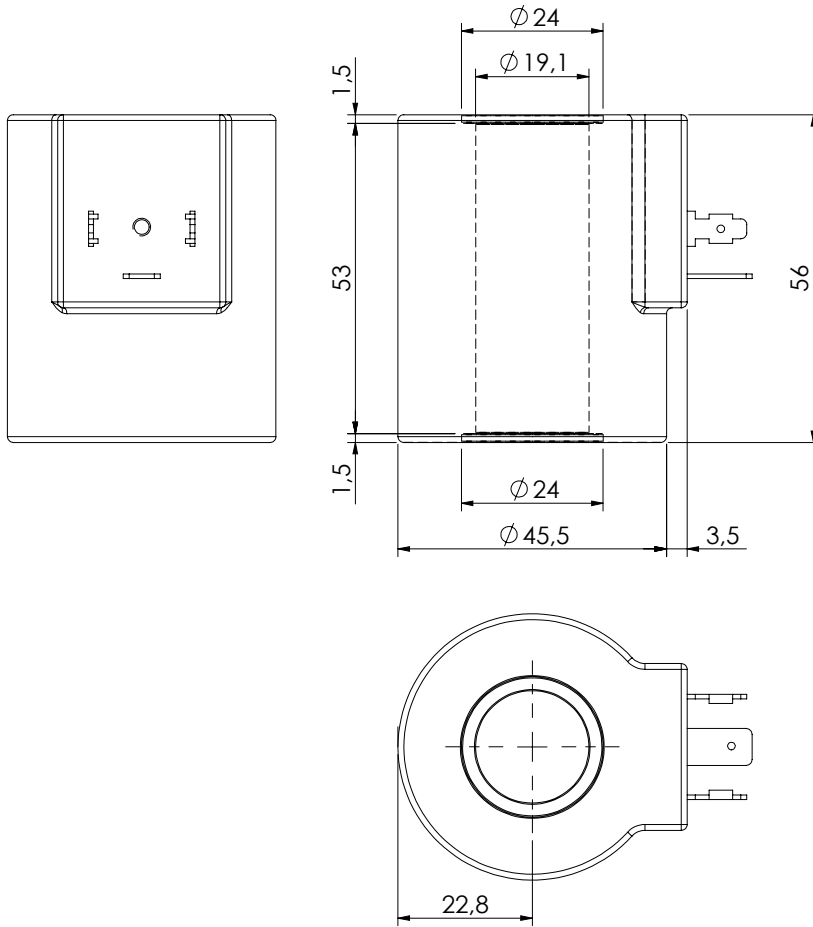

SPECIFICATIONS

Heat insulation class H	180°C
Ambient temperature	-30 + 60°C
Inlet voltage	±10% tol.
Insulation class IP69K with all seals properly mounted	
Weight:	0,18 kg

NOTES

ORDERING CODES

Quick code	Description	Connector type	Voltage (V)	Resistance (Ω) ±7%	Power (w)	Current (A)
AB000015	Coil M8 HS 12V CLASS H	DIN 43650-ISO 4400	12 DC	4.4	33 W	2.75
AB000029	Coil M8 HS 24V CLASS H	DIN 43650-ISO 4400	24 DC	17.5	33 W	1.38
AB000159	Coil M8 HS 14V CLASS H	DIN 43650-ISO 4400	14 DC	5.94	33 W	2.36
AB000160	Coil M8 HS 26V CLASS H	DIN 43650-ISO 4400	26 DC	20.48	33 W	1.27
AB000158	Coil M8 HS 48V CLASS H	DIN 43650-ISO 4400	48 DC	69.81	33 W	0.69

COIL

COIL SERIES M11

DIN 43650 - ISO 4400
CLASS H

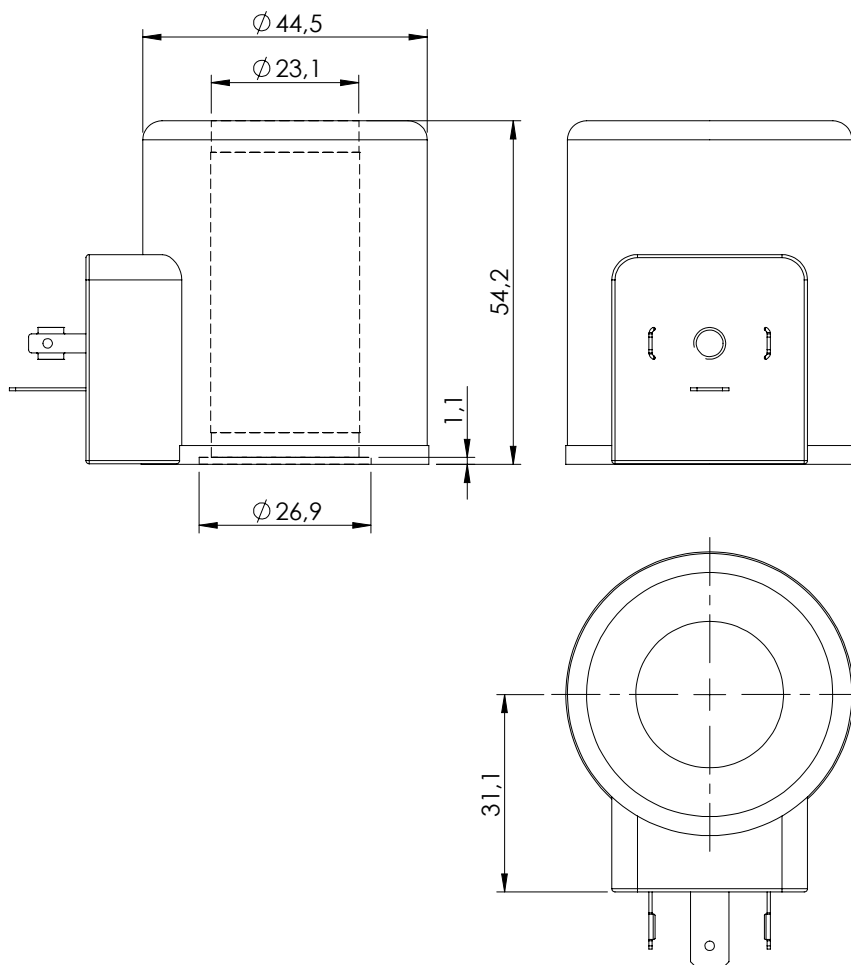
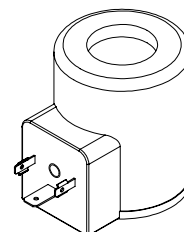

SPECIFICATIONS

Heat insulation class H	180°C
Ambient temperature	-30 + 60°C
Inlet voltage	±10% tol.
Insulation class IP69K with all seals properly mounted	
Weight:	0,18 kg

NOTES

ORDERING CODES

Quick code	Description	Connector type	Voltage (V)	Resistance (Ω) ±7%	Power (w)	Current (A)
AB000149	Coil M11 HS 12V CLASS H	DIN 43650-ISO 4400	12 DC	3.27	44	3.67
AB000150	Coil M11 HS 24V CLASS H	DIN 43650-ISO 4400	24 DC	13.09	44	1.83

CONNECTOR

DIN CONNECTOR

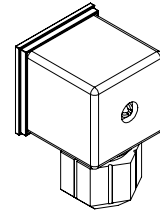
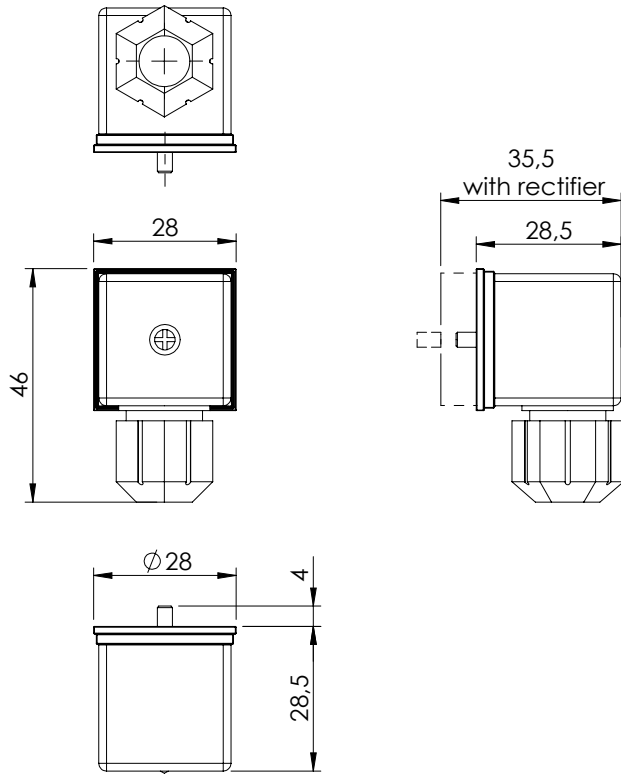

SPECIFICATIONS

Voltage rating:	AC: up to 250 V Max. DC: up to 300 V Max.
Max. Current	16.0 A
Contact resistance:	≤ 4 mΩ
Max. conductor:	1.5 mm ²
Cable range	Ø4.0 to Ø9.0 mm
Protection class:	IP67 EN60529
Seal:	Nitrile rubber
Poles:	2 + ground
Connector:	EN 175301-803 (DIN 43650)

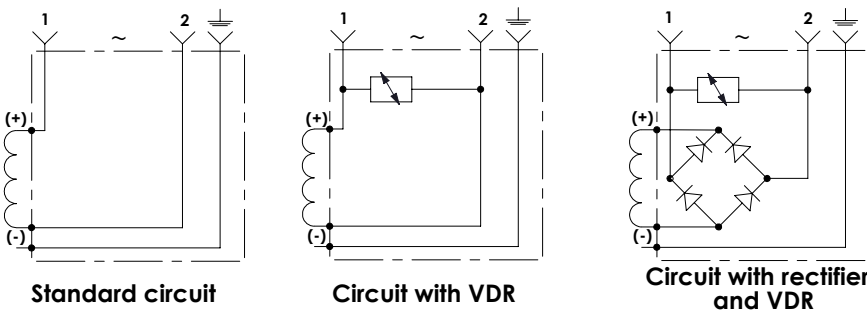

ORDERING CODES

Quick code	Colour	VDR	LED	Rectifier	Voltage
PV000171	Black	No	No	No	12V to 230V
PV000195	Black	Yes	No	No	12V DC
PV000349	Black	Yes	No	No	24V DC
PV000347	Black	Yes	No	Yes	12V RAC
PV000198	Transparent	Yes	Yes	No	12V DC
PV000348	Black	Yes	No	Yes	24V RAC
PV000196	Transparent	Yes	Yes	No	24V DC
PV000199	Black	Yes	No	Yes	230V RAC
PV000243	Transparent	Yes	Yes	No	230V DC



ATLANTIC
Fluid Tech

SECTION 22

Accessories
and Spare



OIL SOLUTIONS

1800-OILSOL
1800-645765

<https://oilsolutions.com.au/>

sales@oilsolutions.com.au

SECTION 22

ACCESSORIES AND SPARE



Hydraulic scheme	Valve description	Valve type	Rated flow (l/min)	Max. pressure (bar)	Installation	Main port size or cavity type	Page
	Filter G 1/4"	300 micron filtration	25	Δp 35	Insert	G1/4"	22.00.010
	Filter G 3/8"	300 micron filtration	50	Δp 35	Insert	G3/8"	22.00.010
	Filter G 1/8"	300 micron filtration	10	Δp 35	Insert	G1/8"	22.00.010
	Manual override	Detent type	-	-	Screw	-	22.00.020
	Sleeve body G 1/4"	For hose burst and check valve	-	350	In line	G1/4"	22.00.030
	Sleeve body G 3/8"	For hose burst and check valve	-	350	In line	G3/8"	22.00.030
	Sleeve body G 1/2"	For hose burst and check valve	-	350	In line	G1/2"	22.00.030
	Sleeve body G 3/4"	For hose burst and check valve	-	350	In line	G3/4"	22.00.030
	Sleeve body G 1/4"	For flow control valve	-	350	In line	G1/4"	22.00.040
	Sleeve body G 3/8"	For flow control valve	-	350	In line	G3/8"	22.00.040
	Sleeve body G 1/2"	For flow control valve	-	350	In line	G1/2"	22.00.040
	Sleeve body G 3/4"	For flow control valve	-	350	In line	G3/4"	22.00.040
	CFSN-090-PBSR-06	For flow control valve	0 - 6	350	In line	VP000132	22.00.050
	CFSN-090-PBSR-12	For flow control valve	0 - 12	350	In line	VP000132	22.00.050
	CFSN-090-PBSR-25	For flow control valve	0 - 25	350	In line	VP000132	22.00.050
	CFSN-090-PBSR-32	For flow control valve	0 - 32	350	In line	VP000132	22.00.050
	CFSN-090-PBSR-50	For flow control valve	0 - 50	350	In line	VP000132	22.00.050
	CFSN-090-PBSR-63	For flow control valve	0 - 63	350	In line	VP000132	22.00.050
	CFSN-090-PBSR-70	For flow control valve	0 - 70	350	In line	VP000132	22.00.050
	CFSN-090-PBSR-80	For flow control valve	0 - 80	350	In line	VP000132	22.00.050
	CFSN-200-BHSR	For flow control valve	-	350	In line	VP000096 VP000152	22.00.060
	CFSN-200-BVSR	For flow control valve	-	350	In line	VP000096 VP000152	22.00.060
	CFSN-200-BMSR	For flow control valve	-	350	In line	VP000096 VP000152	22.00.060
	CFSN-090-BHSR	For flow control valve	-	350	In line	VP000132	22.00.060
	CFSN-090-BVSR	For flow control valve	-	350	In line	VP000132	22.00.060
	CFSN-090-BMSR	For flow control valve	-	350	In line	VP000132	22.00.060
	CFSN-035-BHSR	For flow control valve	-	350	In line	VP000132	22.00.060
	CFSN-035-BVSR	For flow control valve	-	350	In line	VP000132	22.00.060
	CFSN-035-BMSR	For flow control valve	-	350	In line	VP000132	22.00.060
	VP000057 G 3/4"	Cavity plug	-	-	In line	VP000057	22.00.070
	VP000013 G 1"	Cavity plug	-	-	In line	VP000013	22.00.070
	SAE-08-2N	Cavity plug	-	-	In line	3/4-16 UNF-2B	22.00.080
	SAE-10-2N	Cavity plug	-	-	In line	7/8-14 UNF-2B	22.00.080
	SAE-08-3N	Cavity plug	-	-	In line	3/4-16 UNF-2B	22.00.090
	SAE-10-3N	Cavity plug	-	-	In line	7/8-14 UNF-2B	22.00.090
	SAE-08-4N	Cavity plug	-	-	In line	3/4-16 UNF-2B	22.00.100
	SAE-10-4N	Cavity plug	-	-	In line	7/8-14 UNF-2B	22.00.100
	Seal kit	Cavity Personalized	-	-	-	-	22.00.110
		Cavity SAE	-	-	-	-	22.00.120

ACCESSORIES

FILTER

SCREW IN FILTER

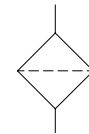
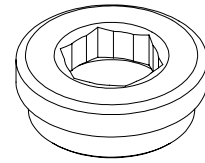
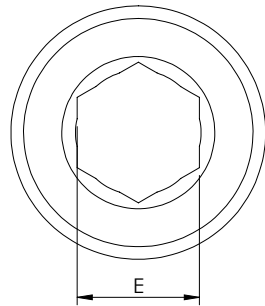
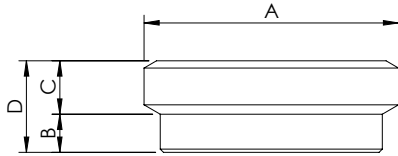

Code	A	B	C	D	E
CT000002	G 3/8"	2.5	3.5	6	8
CT000003	G 1/4"	2	3	5	6
CT000004	G 1/8"	1.6	2.2	3.8	5

SPECIFICATIONS

Max. operating Δp :	35 bar
Rated flow:	See table
Cavity:	See table
Weight:	8 g

APPLICATION LIMITATIONS

- Not suitable for use with:
- fast acting valve
 - cold oil
 - high viscosity oil
 - other conditions creating pressure drop greater than 35 bar
 - max. operating pressure is 350 bar

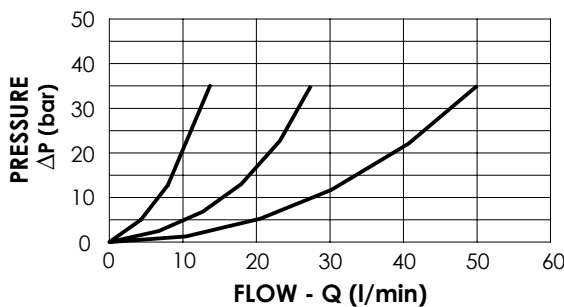

ORDERING CODES

Quick code	Description	Max. ΔP admitted (bar)	Max. flow (l/min)	Filtration (micron)	Installation torque (Nm)
CT000002	Filter G 3/8"	35	50	300	10
CT000003	Filter G 1/4"	35	25	300	5
CT000004	Filter G 1/8"	35	10	300	3

ACCESSORIES



MANUAL OVERRIDE DETENT TYPE

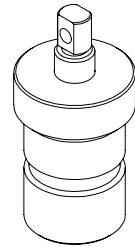
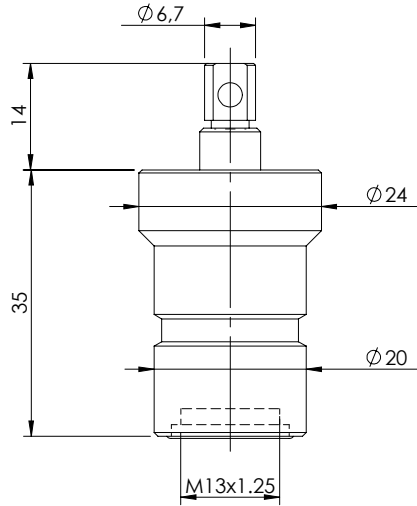

SPECIFICATIONS

Suitable for push style override solenoid valves

ORDERING CODES

Quick code	Description	
ST000364	MANUAL OVERRIDE	

SLEEVE BODY

SLEEVE

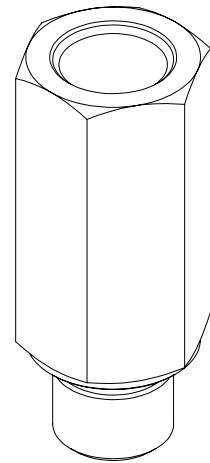
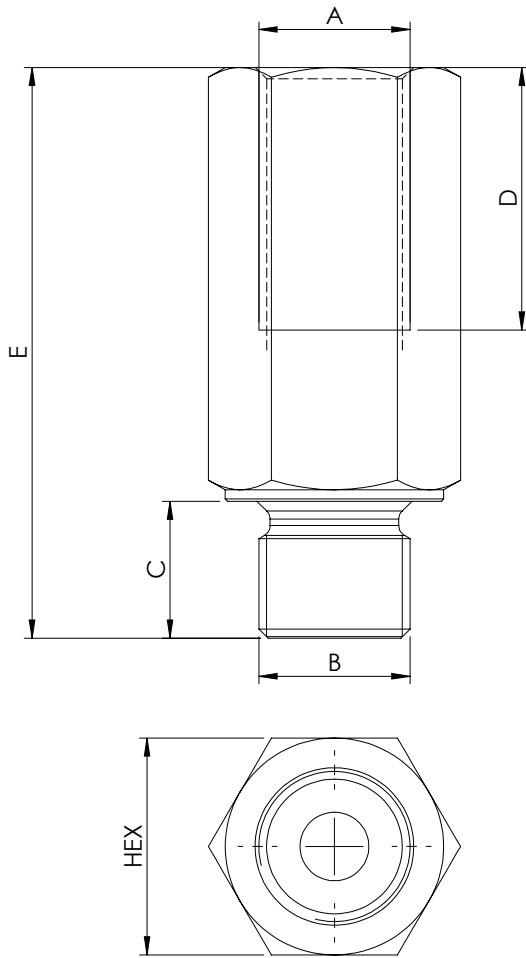

SPECIFICATIONS

Max. operating pressure: 350 bar

Material: Zinc plated steel

NOTES

Suitable for:
-Hose burst valve
CFHN-XXX-MHST

ORDERING CODES

Quick code	A	B	C	D	E	HEX	Weight (Kg)
PC000127	G 1/4"	G 1/4"	12	23	50	19	0,07
PC000128	G 3/8"	G 3/8"	12	27	55	22	0,09
PC000129	G 1/2"	G 1/2"	14	33	63	27	0,15
PC000130	G 3/4"	G 3/4"	16	36	75	32	0,23

SLEEVE BODY

SLEEVE

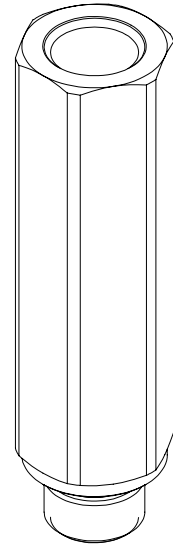
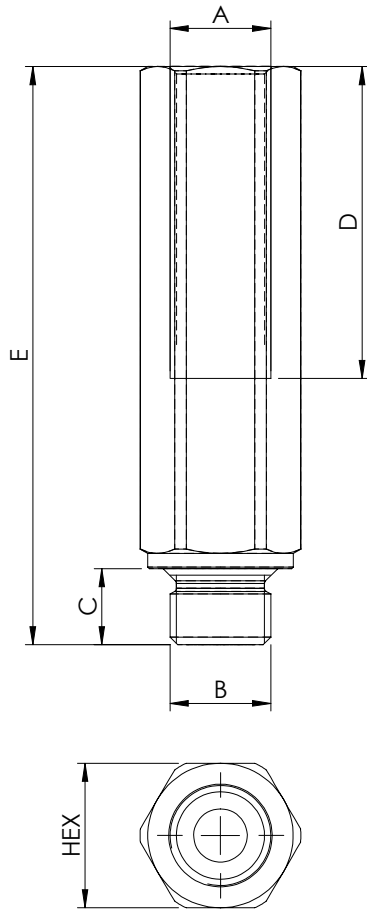

SPECIFICATIONS

Max. operating pressure: 350 bar

Material: Zinc plated steel

NOTES

Suitable for:
-Flow control valves
CFST-XXX-MDST

ORDERING CODES

Quick code	A	B	C	D	E	HEX	Weight (Kg)
PC000196	G 1/4"	G 1/4"	10	41	76	19	0,080
PC000197	G 3/8"	G 3/8"	12	41	82	22	0,110
PC000162	G 1/2"	G 1/2"	14	45	100	27	0,165
PC000198	G 3/4"	G 3/4"	16	55	112	32	0,250

ACCESSORIES

CFSN-090-BPSR

FLOW REGULATOR
SPARE PART

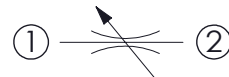
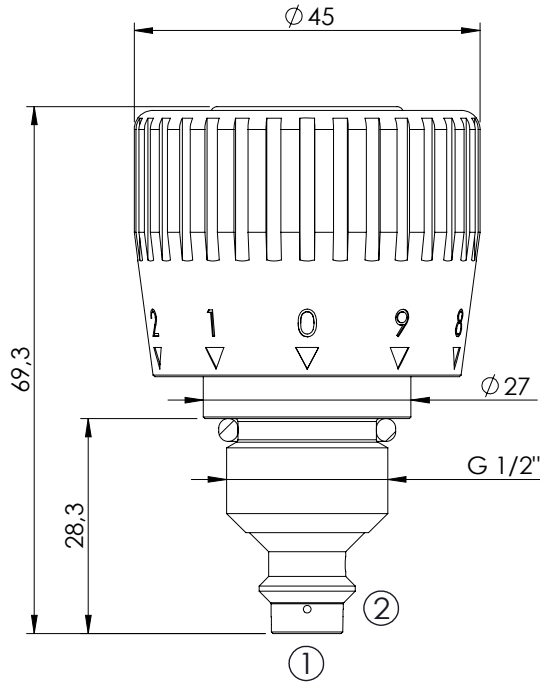
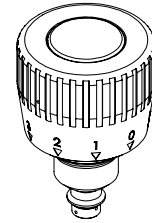

SPECIFICATIONS

Max. operating pressure:	350 bar
Rated flow:	90 l/min
Cavity:	VP000132
Weight:	0,26 kg
Installation torque:	90-100 Nm
Seal kit:	RC700132

ADJUSTMENT OPTIONS

Graduated handknob for flow regulation under pressure

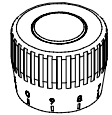

NOTE

Components we be supplied partially disassembled.
Contact AFT sales network for assembling instruction

ORDERING CODES

Quick code	Description	Flow range adjustment (l/min)	Adjustment option
CF000237	CFSN-090-BPSR-06-132-N350	0 - 6	Graduated handknob
CF000238	CFSN-090-BPSR-12-132-N350	0 - 12	Graduated handknob
CF000239	CFSN-090-BPSR-25-132-N350	0 - 25	Graduated handknob
CF000240	CFSN-090-BPSR-32-132-N350	0 - 32	Graduated handknob
CF000392	CFSN-090-BPSR-50-132-N350	0 - 50	Graduated handknob
CF000242	CFSN-090-BPSR-63-132-N350	0 - 63	Graduated handknob
CF000243	CFSN-090-BPSR-70-132-N350	0 - 70	Graduated handknob
CF000244	CFSN-090-BPSR-80-132-N350	0 - 80	Graduated handknob

ACCESSORIES

FLOW CONTROL



	REGULATION TYPE			
	STANDARD (G 3/4")	STANDARD (G 1/2")	FINE	
A D J U S T M E N T T Y P E	<p>40,3 max. Hex.30 Screw and locknut</p>	<p>38 max. Hex.27 Screw and locknut</p>	<p>38,8 max. Hex.27 Screw and locknut</p>	
	<p>45 max. Ø 38 Handknob and locknut</p>	<p>44 max. Ø 38 Handknob and locknut</p>	<p>44,5 max. Ø 38 Handknob and locknut</p>	
	<p>44,5 max. Ø 45 Graduated handknob</p>	<p>41,5 max. Ø 45 Graduated handknob</p>	<p>42 max. Ø 45 Graduated handknob</p>	
R E G U L A T I O N	<p>31,3 G3/4" Totally closed</p>	<p>24 G1/2" Totally closed</p>	<p>24 G1/2" Totally closed</p>	<p>NOTES</p> <ul style="list-style-type: none"> -Spare parts for flow regulations parts parts in body. -Contact AFT sales network for assembling instruction.

SPECIFICATIONS

Max. operating pressure:	350 bar
Regulated flow:	See table
Cavity:	See table
Weight:	0,1 kg

ORDERING CODES

Quick code	Description	Adjustment Options	Regulated sensivity	Max flow regulation (l/min)	Cavity	Install. torque (Nm)
CF000015	CFSN-200-BHSR-NP-096-N350	Screw and locknut	Standard (G3/4")	90 - 190	VP000096 VP000152	120-150
CF000030	CFSN-200-BVSR-NP-096-N350	Handknob and locknut	Standard (G3/4")	90 - 190	VP000096 VP000152	120-150
CF000042	CFSN-200-BMSR-NP-096-N350	Graduated handknob	Standard (G3/4")	90 - 190	VP000096 VP000152	120-150
CF000029	CFSN-090-BHSR-NP-132-N350	Screw and locknut	Standard (G1/2")	55	VP000132	75-85
CF000019	CFSN-090-BVSR-NP-132-N350	Handknob and locknut	Standard (G1/2")	55	VP000132	75-85
CF000033	CFSN-090-BMSR-NP-132-N350	Graduated handknob	Standard (G1/2")	55	VP000132	75-85
CF000036	CFSN-035-BHSR-NP-132-N350	Screw and locknut	Fine	30	VP000132	75-85
CF000037	CFSN-035-BVSR-NP-132-N350	Handknob and locknut	Fine	30	VP000132	75-85
CF000034	CFSN-035-BMSR-NP-132-N350	Graduated handknob	Fine	30	VP000132	75-85

VP000057/VP000013

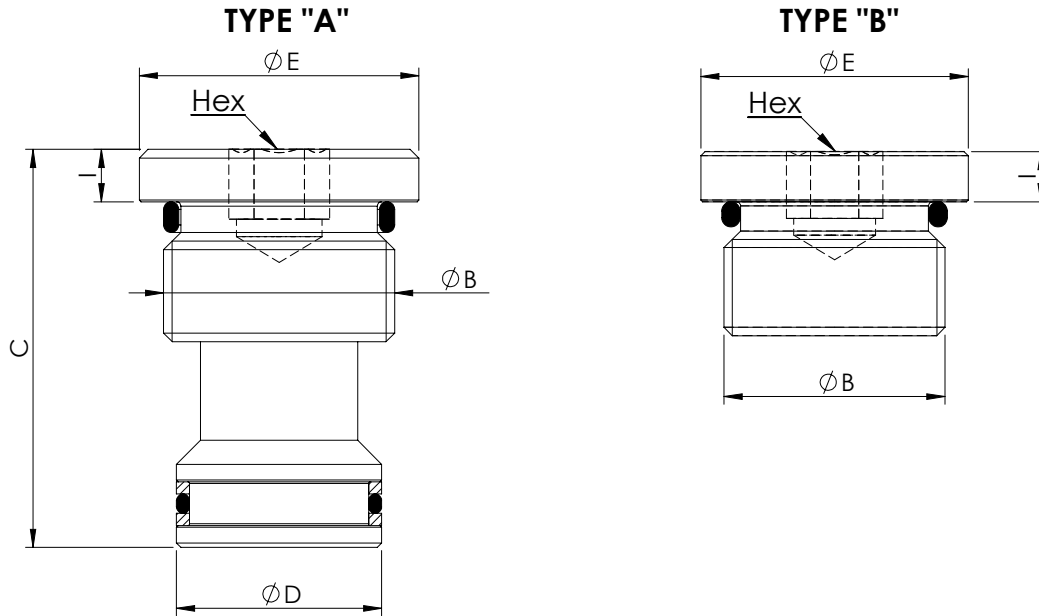

CAVITY A	DIMENSION (mm)								CODE Type " A "	TORQUE (Nm)	CODE Type " B "	TORQUE (Nm)
	B	C	D	E	F	G	Hex	I				
VP000057	G 3/4"	45,5	23,5	32			10	6	ST000259	110-130	ST000278	110-130
VP000013	G 1"	55	30	38			13	6	ST000337	135-150	ST000338	135-150

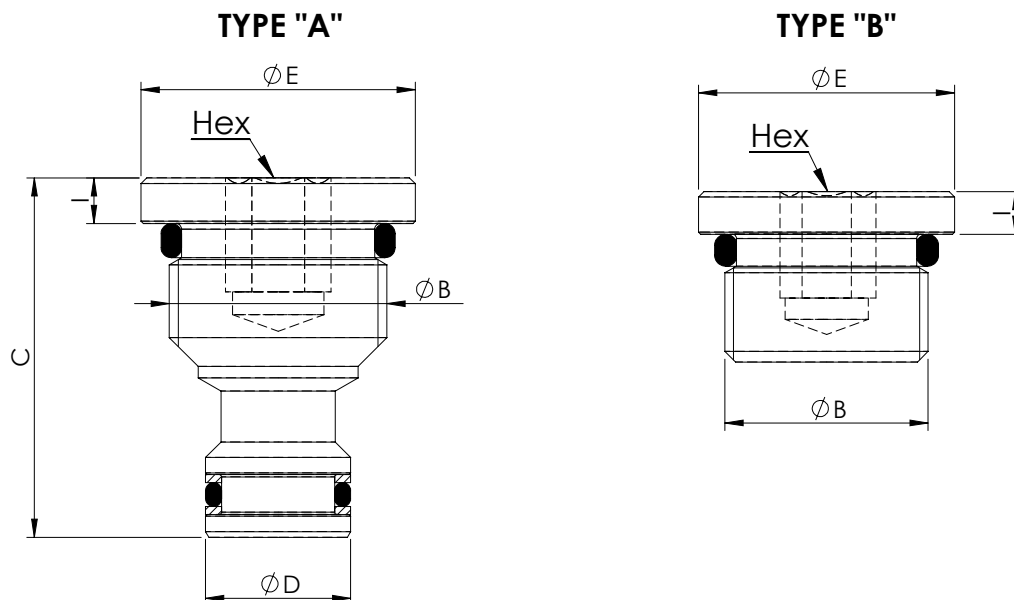

CAVITY A	DIMENSION (mm)								CODE Type " A "	TORQUE (Nm)	CODE Type " B "	TORQUE (Nm)
	B (UNF-2A)	C	D	E	F	G	Hex	I				
SAE-08-2N	3/4-16	31,5	12,7	24			8	4	ST000027	45-50	ST000331	45-50
SAE-10-2N	7/8-14	38	15,87	27			10	6	ST000332	50-55	ST000333	50-55
SAE-12-2N	1 1/16-12			32			13	6			ST000208	100-110
SAE-16-2N	1 5/16-12			38			15	6			ST000396	170-190
SAE-20-2N	1 5/8-12			46			17	6			ST000397	280-320

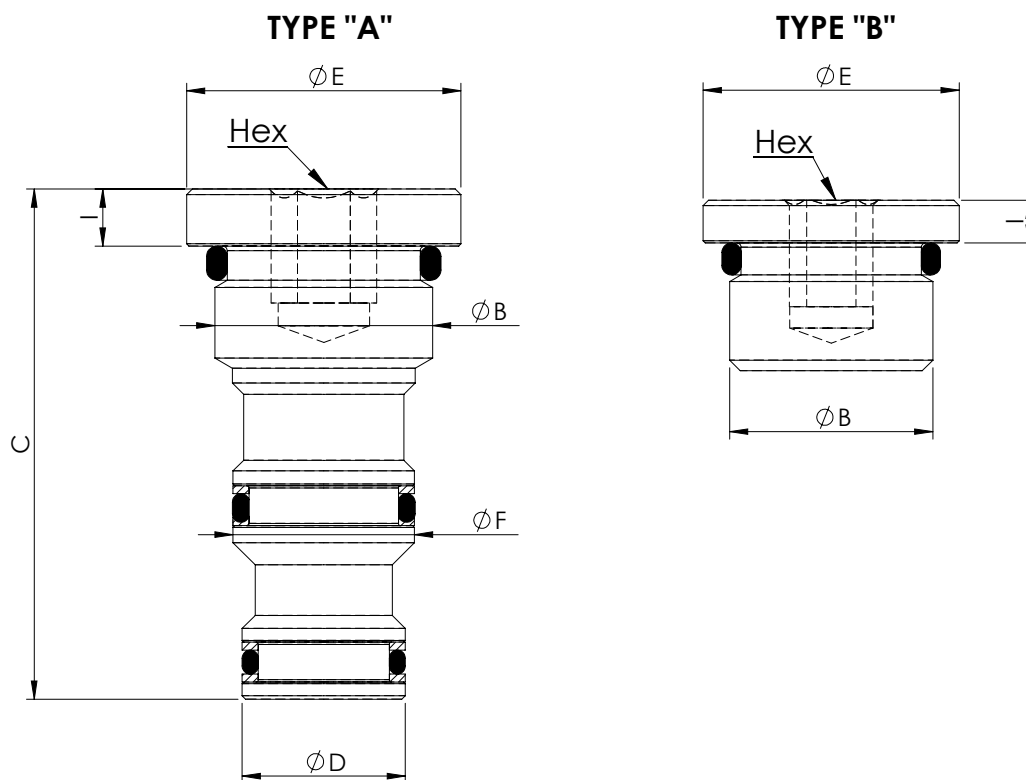
SAE-XXX-3N

CAVITY A	B (UNF-2B)	DIMENSION (mm)							CODE Type " A "	TORQUE (Nm)	CODE Type " B "	TORQUE (Nm)
		C	D	E	F	G	Hex	I				
SAE-08-3N	3/4-16	44,7	14,27	24	15,87		8	5	ST000292	45-50	ST000331	45-50
SAE-10-3N	7/8-14	53	15,87	27	17,47		10	6	ST000334	50-55	ST000333	50-55
SAE-12-3N	1 1/16-12			32			13	6			ST000208	100-110
SAE-16-3N	1 5/16-12			38			15	6			ST000396	170-190
SAE-20-3N	1 5/8-12			46			17	6			ST000397	280-320

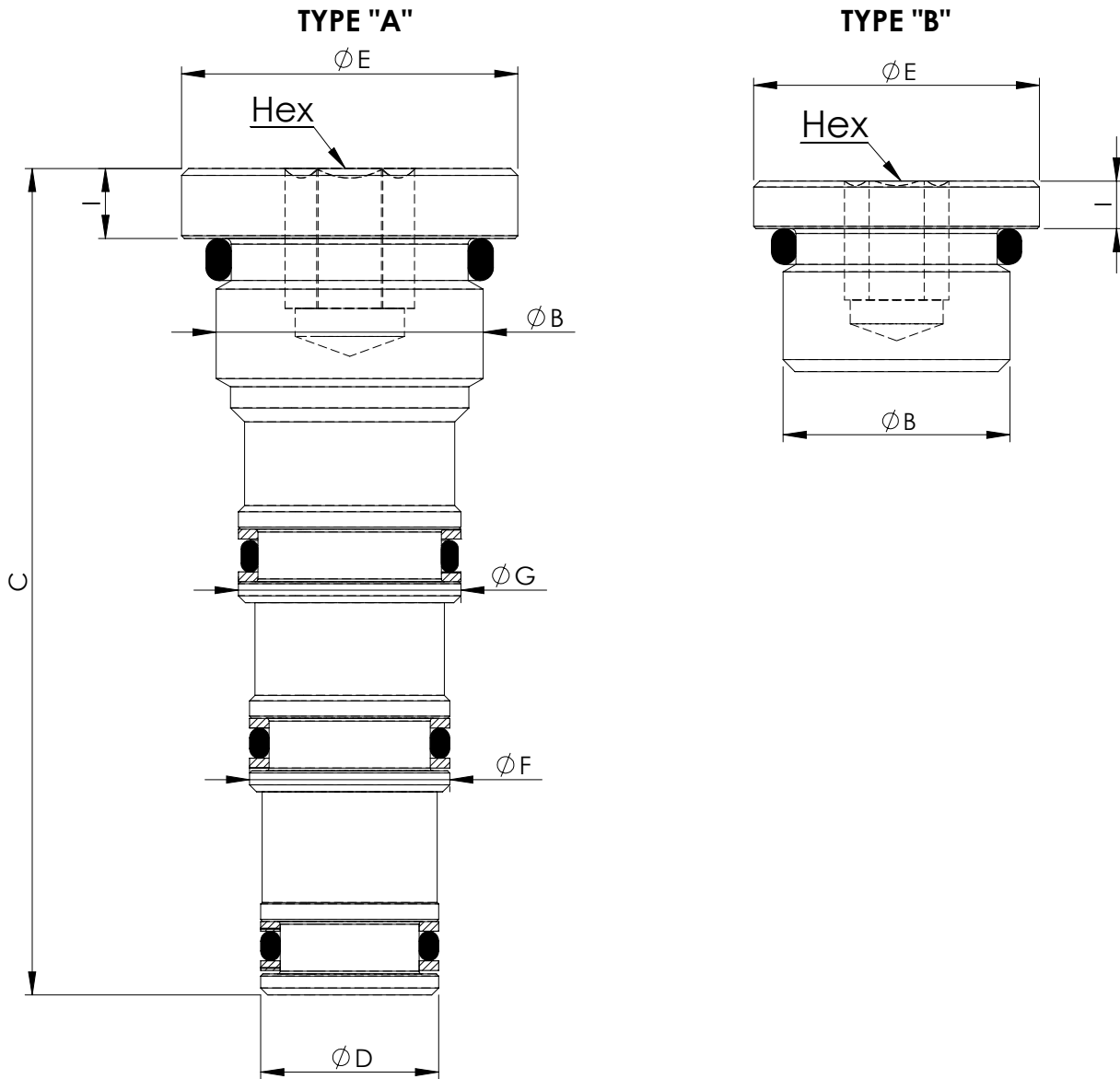

CAVITY A	DIMENSION (mm)								CODE Type " A "	TORQUE (Nm)	CODE Type " B "	TORQUE (Nm)
	B (UNF-2B)	C	D	E	F	G	Hex	I				
SAE-08-4N	3/4-16	59	12,7	24	14,28	15,87	8	5	ST000335	45-50	ST000331	45-50
SAE-10-4N	7/8-14	68,6	15,87	27	17,47	19,05	10	6	ST000336	50-55	ST000333	50-55
SAE-12-4N	1 1/16-12			32			13	6			ST000208	100-110
SAE-16-4N	1 5/16-12			38			15	6			ST000396	170-190
SAE-20-4N	1 5/8-12			46			17	6			ST000397	280-320

SEAL KIT

SEAL KIT-SPECIAL CAVITIES



CAVITY	BACKUP RING TYPE	NBR 70	NBR 90	VITON 80
VP000005	Single backup ring	RC700005		
	Double backup ring			
VP000006	Single backup ring	RC700006		
	Double backup ring			
VP000008	Single backup ring	RC700008		
	Double backup ring			
VP000013	Single backup ring		RC900013	
	Double backup ring		RD900013	
VP000015	Single backup ring	RC700015		
	Double backup ring			
VP000016	Single backup ring	RC700016		
	Double backup ring			
VP000018	Single backup ring	-		
	Double backup ring	-		
VP000028	Single backup ring	RC700028		
	Double backup ring			
VP000038	Single backup ring	RC700038		
	Double backup ring			
VP000057	Single backup ring		RC900057	
	Double backup ring		RD900057	
VP000058	Single backup ring	RC700058		
	Double backup ring			
VP000065	Single backup ring		RC900065	
	Double backup ring		RD900065	
VP000070	Single backup ring	RC700070		
	Double backup ring			
VP000079	Single backup ring	-		
	Double backup ring	-		
VP000080	Single backup ring		RC900080	
	Double backup ring			
VP000086	Single backup ring	RC700086		
	Double backup ring			
VP000096	Single backup ring			
	Double backup ring			
VP000098	Single backup ring	RC700098		
	Double backup ring			
VP000120	Single backup ring			
	Double backup ring	RD700120		
VP000121	Single backup ring			
	Double backup ring	RD700121		

SEAL KIT



SEAL KIT - SPECIAL CAVITIES

CAVITY	BACKUP RING TYPE	NBR 70	NBR 90	VITON 80
VP000127	Single backup ring			
	Double backup ring		RD900127	
VP000128	Single backup ring			
	Double backup ring		RD900128	
VP000132	Single backup ring			
	Double backup ring	RC700132		
VP000154	Single backup ring		RC900154	
	Double backup ring			
VP000158	Single backup ring	-		
	Double backup ring	-		
VP000161	Single backup ring	RC700161		
	Double backup ring			
VP000165	Single backup ring	RC700165		
	Double backup ring			
VP000166	Single backup ring	RC700166		
	Double backup ring			
VP000174	Single backup ring			
	Double backup ring	RD700174		
VP000178	Single backup ring	RC700178		
	Double backup ring			
VP000180	Single backup ring			
	Double backup ring			
VP000189	Single backup ring	RC700189		
	Double backup ring			
VP000193	Single backup ring	RC700193		
	Double backup ring			
VP000198	Single backup ring			
	Double backup ring	RD700198		
VP000202	Single backup ring	-		
	Double backup ring	-		
VP000204	Single backup ring	RC700204		
	Double backup ring			
VP000216	Single backup ring	RC700216		
	Double backup ring			
VP000249	Single backup ring		RC900249	
	Double backup ring			
VP000250	Single backup ring		RC900250	
	Double backup ring			
VP000263	Single backup ring	RC700263		
	Double backup ring			

SEAL KIT

SEAL KIT-STANDARD CAVITIES



CAVITY	BACKUP RING TYPE	NBR 70	NBR 90	VITON 80
SAE-08-2N	Single backup ring	RA700081	RA900081	
	Double backup ring	RB700081	RB900081	
SAE-10-2N	Single backup ring	RA700082	RA900082	
	Double backup ring	RB700082	RB900082	
SAE-12-2N	Single backup ring	RA700083	RA900083	
	Double backup ring			
SAE-16-2N	Single backup ring	RA700084	RA900084	
	Double backup ring			
SAE-20-2N	Single backup ring		RA900085	
	Double backup ring			
SAE-08-3C	Single backup ring	RA700086		
	Double backup ring			
SAE-10-3C	Single backup ring	RA700087		
	Double backup ring	RB700087		
SAE-12-3C	Single backup ring			
	Double backup ring			
SAE-16-3C	Single backup ring			
	Double backup ring			
SAE-20-3C	Single backup ring			
	Double backup ring		RB900090	
SAE-08-3N	Single backup ring			
	Double backup ring	RB700091		
SAE-10-3N	Single backup ring	RA700092		
	Double backup ring	RB700092		
SAE-12-3N	Single backup ring	RA700093		
	Double backup ring			
SAE-16-3N	Single backup ring			
	Double backup ring	RB700094		
SAE-20-3N	Single backup ring			
	Double backup ring			
SAE-08-4N	Single backup ring			
	Double backup ring	RB700101		
SAE-10-4N	Single backup ring			
	Double backup ring	RB700102		
SAE-12-4N	Single backup ring			
	Double backup ring	RB700103		
SAE-16-4N	Single backup ring			
	Double backup ring	RB700104		
SAE-20-4N	Single backup ring			
	Double backup ring			



ATLANTIC
Fluid Tech

SECTION 23

Standard
Manifolds



1800-OILSOL
1800-645765

<https://oilsolutions.com.au/>

sales@oilsolutions.com.au

SECTION 23

STANDARD MANIFOLDS



Description	Material	Valve type	Max. pressure (bar)	Installation	Port size	Page
SAE-XX-2N	Aluminium	Two way	250	In line	See datasheet	23.00.010
SAE-XX-2N	Steel	Two way	350	In line	See datasheet	23.00.020
SAE-XX-3C	Aluminium	Three way	250	In line	See datasheet	23.00.030
SAE-XX-3C	Steel	Three way	350	In line	See datasheet	23.00.030
SAE-XX-3N	Aluminium	Three way	250	In line	See datasheet	23.00.040
SAE-XX-3N	Steel	Three way	350	In line	See datasheet	23.00.040
SAE-XX-4N-3P	Aluminium	Four way, three ports	250	In line	See datasheet	23.00.050
SAE-XX-4N-3P	Steel	Four way, three ports	350	In line	See datasheet	23.00.050
SAE-XX-4N	Aluminium	Four way	250	In line	See datasheet	23.00.060
SAE-XX-4N	Steel	Four way	350	In line	See datasheet	23.00.060
VP000057	Aluminium	Two way	250	In line	See datasheet	23.00.070
VP000057	Steel	Two way	350	In line	See datasheet	23.00.070
VP000013	Aluminium	Two way	250	In line	See datasheet	23.00.070
VP000013	Steel	Two way	350	In line	See datasheet	23.00.070
VP000180	Aluminium	Two way	250	In line	See datasheet	23.00.070
VP000180	Steel	Two way	350	In line	See datasheet	23.00.070
SAE-XX-2N	Aluminium	Two way, with override screw	250	In line	See datasheet	23.00.080
SAE-XX-2N	Steel	Two way, with override screw	350	In line	See datasheet	23.00.080
VP000057	Aluminium	Two way, with override screw	250	In line	See datasheet	23.00.090
VP000057	Steel	Two way, with override screw	350	In line	See datasheet	23.00.090
VP000013	Aluminium	Two way, with override screw	250	In line	See datasheet	23.00.090
VP000013	Steel	Two way, with override screw	350	In line	See datasheet	23.00.090

STANDARD MANIFOLDS

SAE-XX-2N

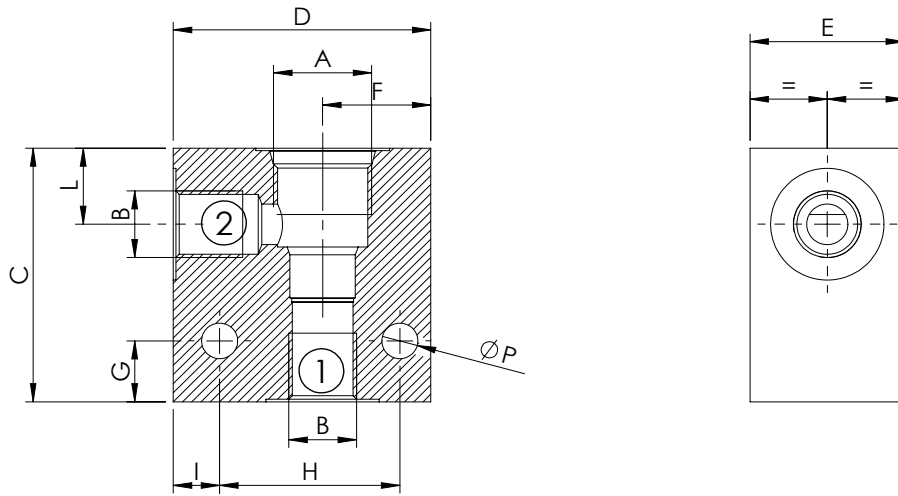

CAVITY	DIMENSIONS (mm)												QUICK CODE		
	A	B	C	D	E	F	G	H	I	L	M	N	P	Steel	Aluminium
SAE-08-2N	G 1/4"	50	50	30	21	12	35	9	15				7	LK000018	LK000017
	G 3/8"	50	50	30	21	12	35	9	15				7	LK000020	LK000019
	G 1/2"	50	50	35	23	12	35	9	16				7	LK000390	LK000247
	7/16-20	50	50	30	21	12	35	9	15				7		
	9/16-18	50	50	30	21	12	35	9	15				7		
SAE-10-2N	G 3/8"	60	60	35	25	15	45	7	19				7	LK000022	LK000021
	G 1/2"	60	60	35	25	15	45	7	19				7	LK000024	LK000023
	G 3/4"	60	60	40	27,5	15	45	9	20				7	LK000047	LK000046
SAE-12-2N	G 1/2"	75	80	40	35	20	60	10	26,5				9	LK000207	LK000208
	G 3/4"	75	80	40	35	20	60	10	26,5				9	LK000205	LK000206
SAE-16-2N	G 3/4"	80	90	50	37	22	60	20	26				9	LK000156	LK000157
	G 1"	80	90	50	37	22	60	20	26				9	LK000154	LK000155
SAE-20-2N															

STANDARD MANIFOLDS

SAE-XX-2N

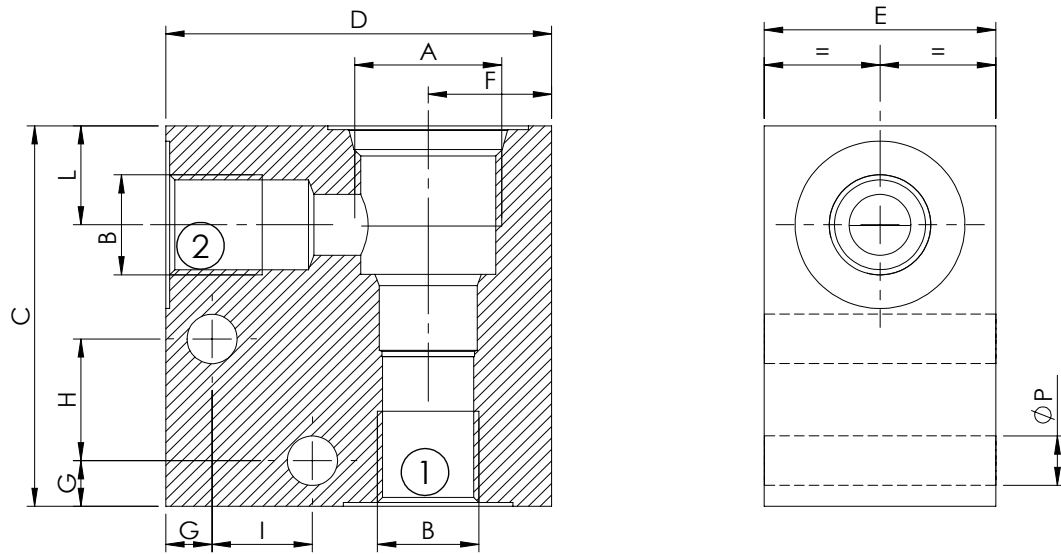

CAVITY	DIMENSIONS (mm)												QUICK CODE		
	A	B	C	D	E	F	G	H	I	L	M	N	P	Steel	Aluminium
SAE-08-2N		G 1/4"	50	50	30	16	6	16	13	13			6,5	LK000086	LK000005
		G 3/8"	50	50	30	16	6	16	13	13			6,5	LK000085	LK000077
		7/16-20	50	50	30	16	6	16	13	13			6,5	LK000277	LK000148
		9/16-18	50	50	30	16	6	16	13	13			6,5	LK000076	LK000278
SAE-10-2N															
SAE-12-2N															
SAE-16-2N															
SAE-20-2N															

STANDARD MANIFOLDS

SAE-XX-3C

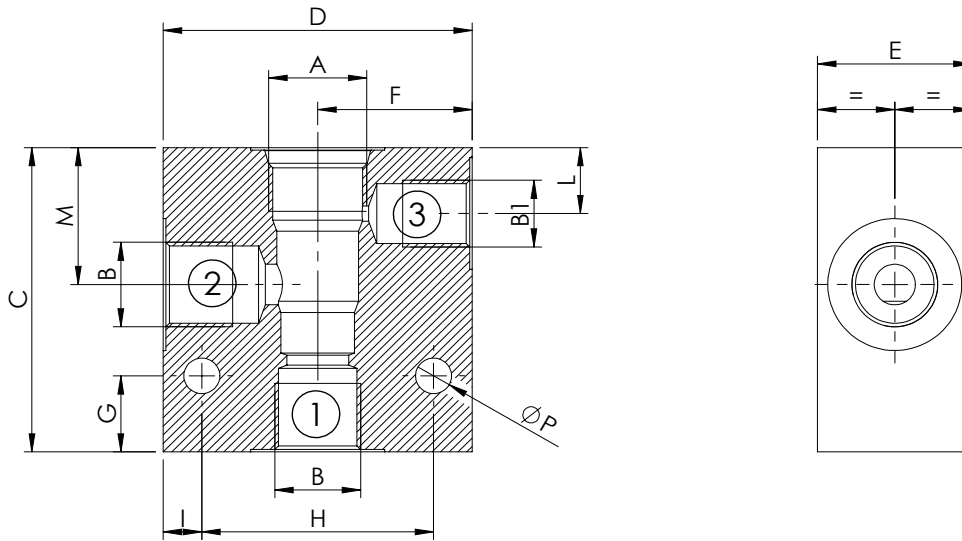

CAVITY	DIMENSIONS (mm)												QUICK CODE	
	A	B	B1	C	D	E	F	G	H	I	L	M	P	Steel
SAE-08-3C	G 3/8"	G 1/4"	60	60	30	30	15	45	7,5	13	27	7	LK000279	LK000033
SAE-10-3C	G 3/8"	G 1/4"	70	60	35	30	15	45	7,5	15	32	7	LK000280	LK000034
SAE-12-3C	G 1/2"	G 1/4"	80	75	40	35	15	55	10	24	42	7	LK000165	LK000164
	G 3/4"	G 1/4"	90	75	40	35	15	55	10	24	42	7	LK000210	LK000211
	7/8-14	9/16-18	80	75	40	35	15	55	10	24	42	9	LK000263	LK000262
SAE-16-3C	G 1"	G 1/4"	90	90	50	40	22	70	10	18,5	39	9	LK000212	LK000213
	G 3/4"	G 1/4"	90	80	50	38	22	60	10	18,5	39	9	LK000264	LK000265
	1 5/16-12	7/16-20	90	90	50	40	22	70	10	18,5	39	9	LK000266	LK000267
SAE-20-3C	G 1"	G 1/4"	110	100	60	45	25	75	12,5	21	51	11	LK000268	LK000269
	G 1-1/4"	G 1/4"	110	100	60	45	25	75	12,5	21	51	11	LK000270	LK000271
	1 5/8-12	7/16-20	110	100	60	45	25	75	12,5	21	51	11	LK000272	LK000273

STANDARD MANIFOLDS

SAE-XX-3N

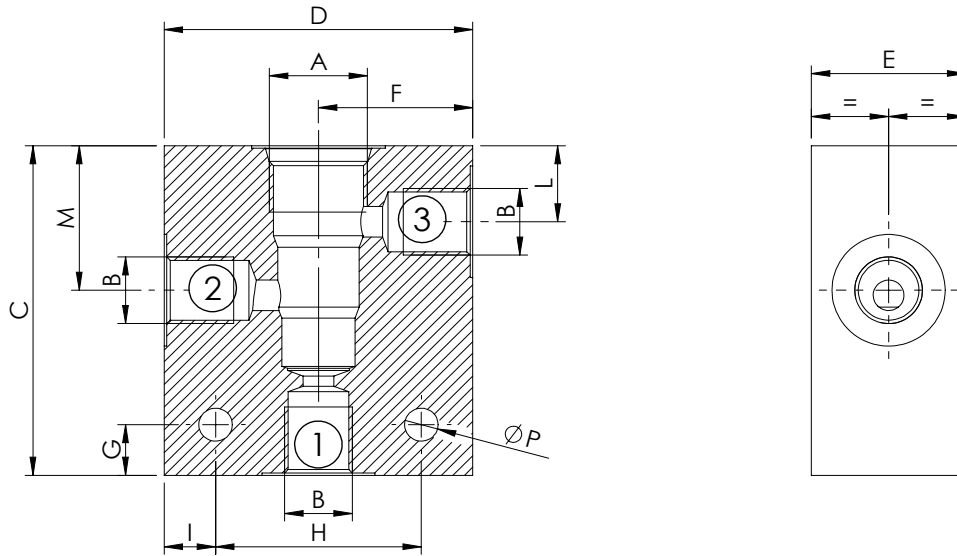

CAVITY	DIMENSIONS (mm)												QUICK CODE	
	A	B	C	D	E	F	G	H	I	L	M	N	P	Steel
SAE-08-3N	G 1/4"	65	60	30	30	10	40	10	15	28,5		6,5	LK000089	LK000008
	G 3/8"	65	60	30	30	10	40	10	15	28,5		6,5	LK000090	LK000009
SAE-10-3N	G 1/4"	65	65	35	32,5	10	50	7,5	18	35		6,5	LK000035	LK000012
	G 3/8"	65	60	35	30	10	45	7,5	18	34,5		7	LK000027	LK000013
	G 1/2"	70	70	35	35	15	50	10	18	34,5		7	LK000131	LK000057
SAE-12-3N	G 1/2"	100	80	40	42,5	15	55	12,5	29	54		7	LK000100	LK000281
	G 3/4"	100	80	40	40	15	55	12,5	29	54		7	LK000294	LK000295
SAE-16-3N	G 3/4"	100	90	50	45	20	60	15	26	54,5		10,5	LK000256	LK000257
SAE-20-3N														

STANDARD MANIFOLDS

SAE-XX-4N 3P

THREE PORTS

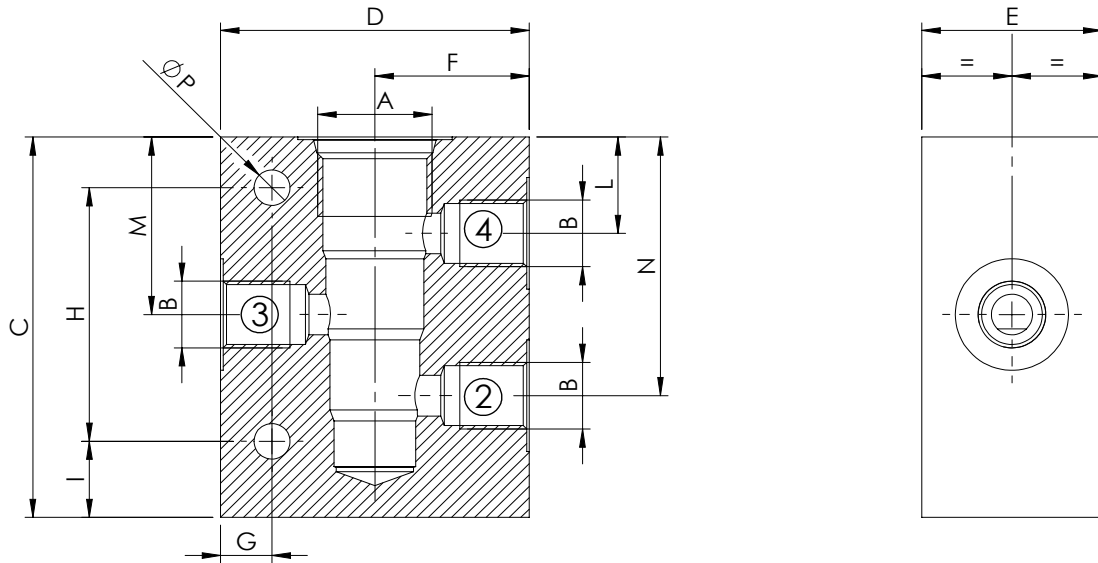

CAVITY	DIMENSIONS (mm)												QUICK CODE	
	A	B	C	D	E	F	G	H	I	L	M	N	P	Steel
SAE-08-4N	G 3/8"	75	60	35	30	10	50	15	15	29	43	7	LK000063	LK000376
SAE-10-4N	G 1/4"	75	60	35	30	10	50	15	19	35	51	7	LK000040	LK000038
	G 3/8"	75	60	35	30	10	50	15	19	35	51	7	LK000016	LK000037
	G 1/2"	85	65	35	32,5	10	50	15	19	35	51	7	LK000041	LK000039
	9/16-18	75	60	35	30	10	50	15	19	35	51	7	LK000331	LK000330
	1/4 JIS	75	60	35	30	10	50	15	19	35	51	7	LK000249	LK000367
SAE-12-4N	G 3/4"	120	80	40	40	12	90	15	28,5	53,5	78,5	7	LK000416	LK000417
SAE-16-4N	G 3/4"	120	90	50	45	12	90	15	25,5	54	82,5	8,5	LK000222	LK000225
	1 1/16 JIS	120	90	50	45	12	90	15	25,5	54	82,5	8,5	LK000223	LK000224
SAE-20-4N														

STANDARD MANIFOLDS

SAE-XX-4N

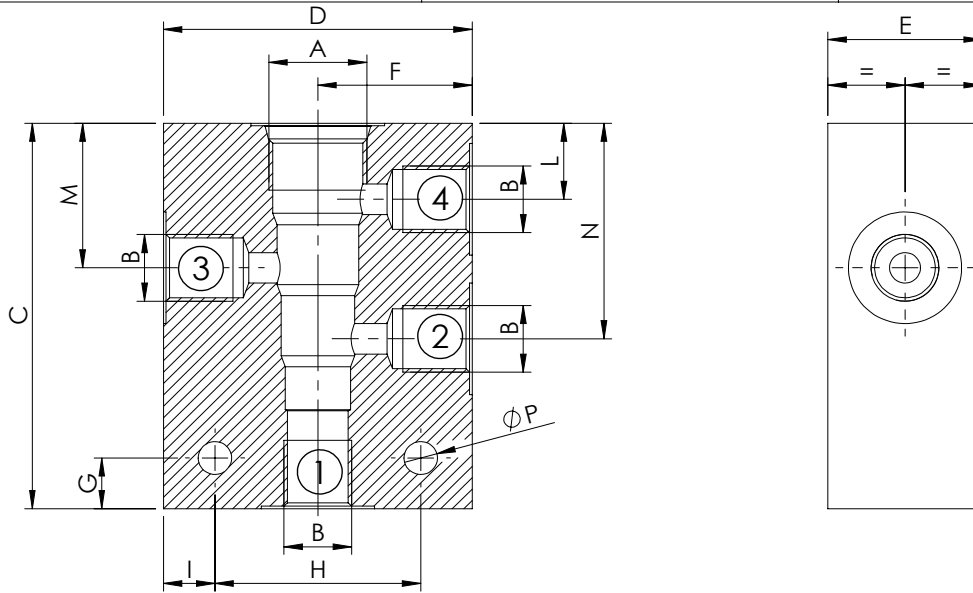

CAVITY	DIMENSIONS (mm)												QUICK CODE	
	A	B	C	D	E	F	G	H	I	L	M	N	P	Steel
SAE-08-4N	G 1/4"	76	60	30	30	10	40	10	15	28,5	42,5	6,5	LK000282	LK000015
	G 3/8"	76	60	30	30	10	40	10	15	28,5	42,5	6,5	LK000276	LK000014
SAE-10-4N	G 1/4"	80	65	35	32,5	10	50	7,5	18	35	50	6,5	LK000231	LK000010
	G 3/8"	85	60	35	30	15	45	7,5	19	35	51	7	LK000043	LK000011
SAE-12-4N	G 3/4"	125	80	40	40	20	55	12,5	28,5	53,5	79,5	7	LK000418	LK000419
SAE-16-4N														
SAE-20-4N														

STANDARD MANIFOLDS

VP000XXX

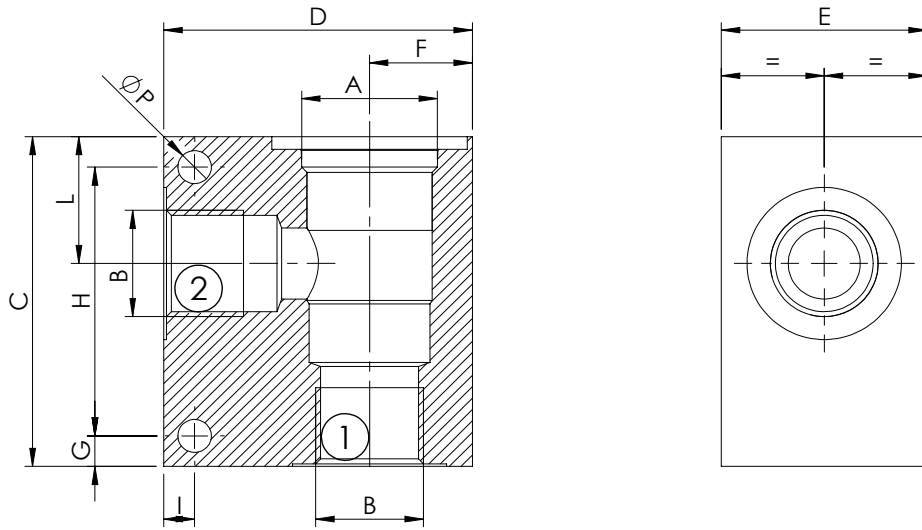

CAVITY	DIMENSIONS (mm)											QUICK CODE			
	A	B	C	D	E	F	G	H	I	L	M	N	P	Steel	Aluminium
VP000057	G 1/2"	65	60	40	20	6	53	6	25				6,5	LK000071	LK000055
	G 3/4"	65	60	40	20	6	53	6	25				6,5	LK000075	LK000065
	3/4-16	65	60	40	20	6	53	6	25				6,5	LK000275	LK000283
	7/8-14	65	60	40	20	6	53	6	25				6,5	LK000363	LK000366
	M22x1,5	65	60	40	20	6	53	6	25				6,5	LK000393	LK000392
VP000013	G 3/4"	80	80	50	26	7,5	65	7,5	31				8,5	LK000078	LK000066
	G 1"	80	80	50	26	7,5	65	7,5	31				8,5	LK000061	LK000042
VP000180	G 1-1/4"	100	90	70	35	17	75	15	39				8,5	LK000087	LK000094

STANDARD MANIFOLDS

VP0000XX

WITH OVERRIDE SCREW

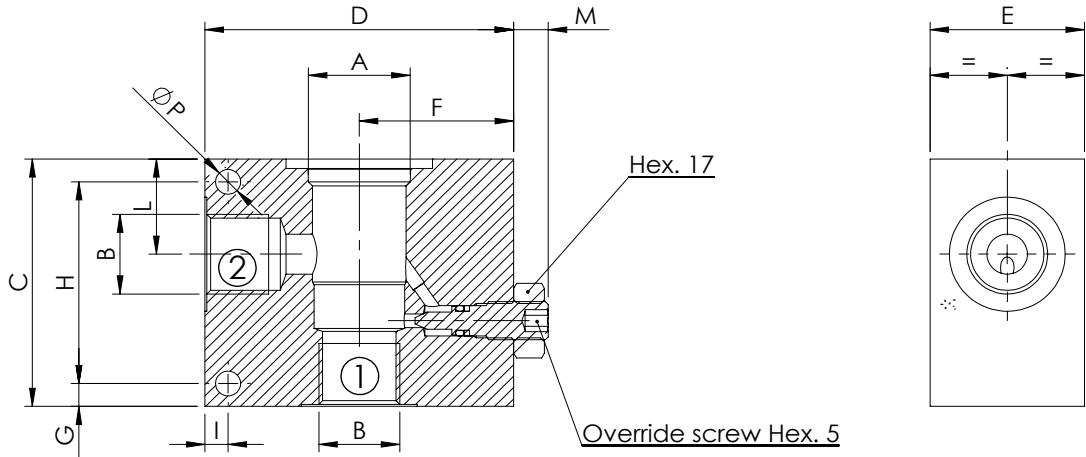

CAVITY	DIMENSIONS (mm)											QUICK CODE				
	A	B	C	D	E	F	G	H	I	L	M	N	P	Steel	Aluminium	
VP000057	G 1/2"	65	80	40	40	6	53	6	25	9			6,5	KS000007	KS000001	
	G 3/4"	65	80	40	40	6	53	6	25	9			6,5	KS000010	KS000004	
VP000013	G 3/4"	80	90	50	47	7,5	65	7,5	31	9			8,5	KS000012	KS000005	
	G 1"	80	90	50	47	7,5	65	7,5	31	9			8,5	KS000011	KS000006	



ATLANTIC
Fluid Tech

SECTION 24

Cavities and
Technical
Drawings



1800-OILSOL
1800-645765

<https://oilsolutions.com.au/>

sales@oilsolutions.com.au

SECTION 24

CAVITIES AND TECHNICAL DRAWINGS



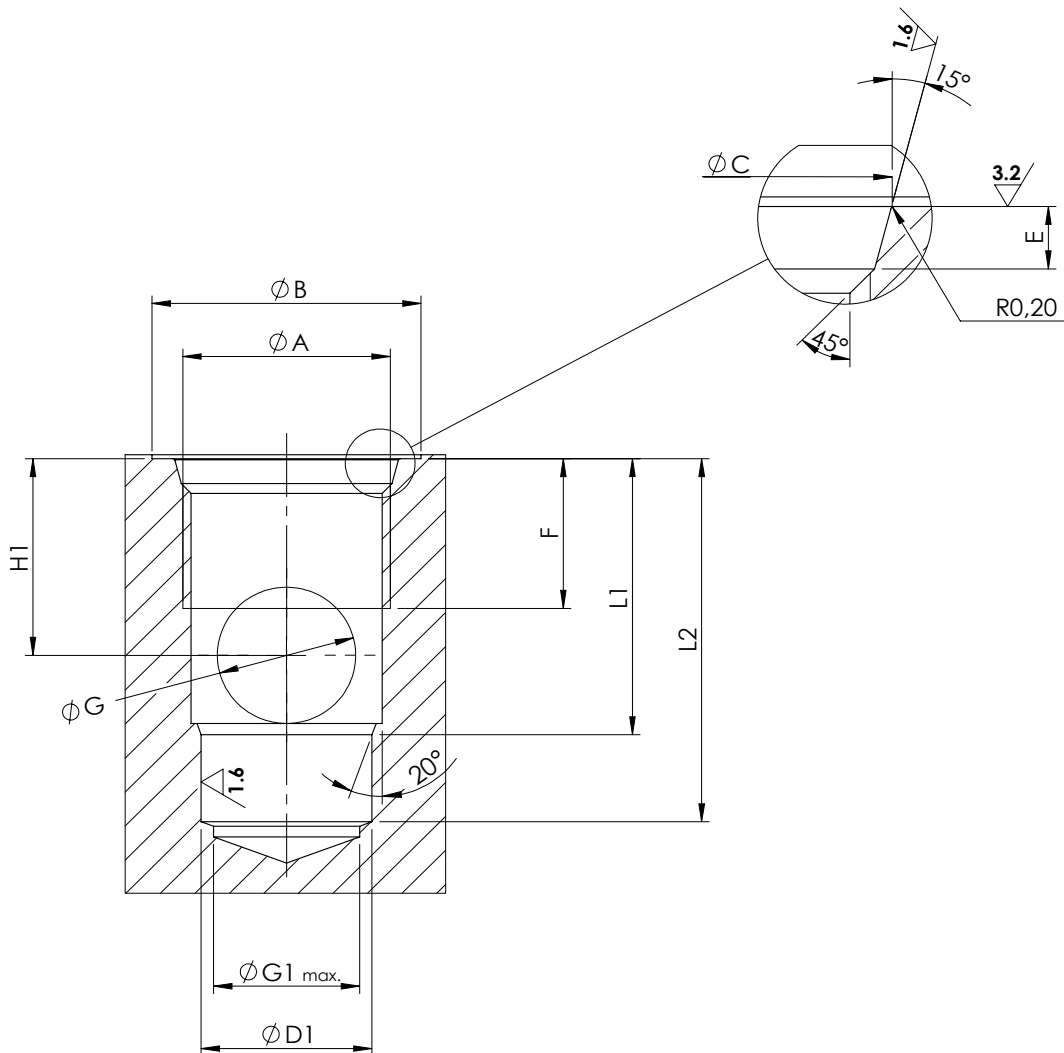

General tolerances : 0.3mm

Ⓞ	0.03
⊥	0.02

	SAE-08-2N	SAE-10-2N	SAE-12-2N	SAE-16-2N	SAE-20-2N
A	3/4-16 UNF	7/8-14 UNF	1-1/16 12 UNF	1-5-16 12 UNF	1-5/8 12 UNF
B	26	30	35	42	48
C	20.6 ^{+0.1} ₀	23.9 ^{+0.1} ₀	29.2 ^{+0.1} ₀	35.5 ^{+0.1} ₀	43.5 ^{+0.1} ₀
D1	12.7 ^{+0.05} ₀	15.87 ^{+0.05} ₀	22.22 ^{+0.05} ₀	28.60 ^{+0.05} ₀	36.52 ^{+0.05} ₀
E	2.6 ^{+0.3} ₀	2.6 ^{+0.3} ₀	3.3 ^{+0.3} ₀	3.3 ^{+0.3} ₀	3.4 ^{+0.3} ₀
F	13	15	20	20	22
G	9	12	18	19	25
G1	12	15	19	24	30
H1	14	18	26	25	32
L1	20.5	25.5	36.5	36	44.5
L2	29	34.5	48	49	59

SAE-XX-3C

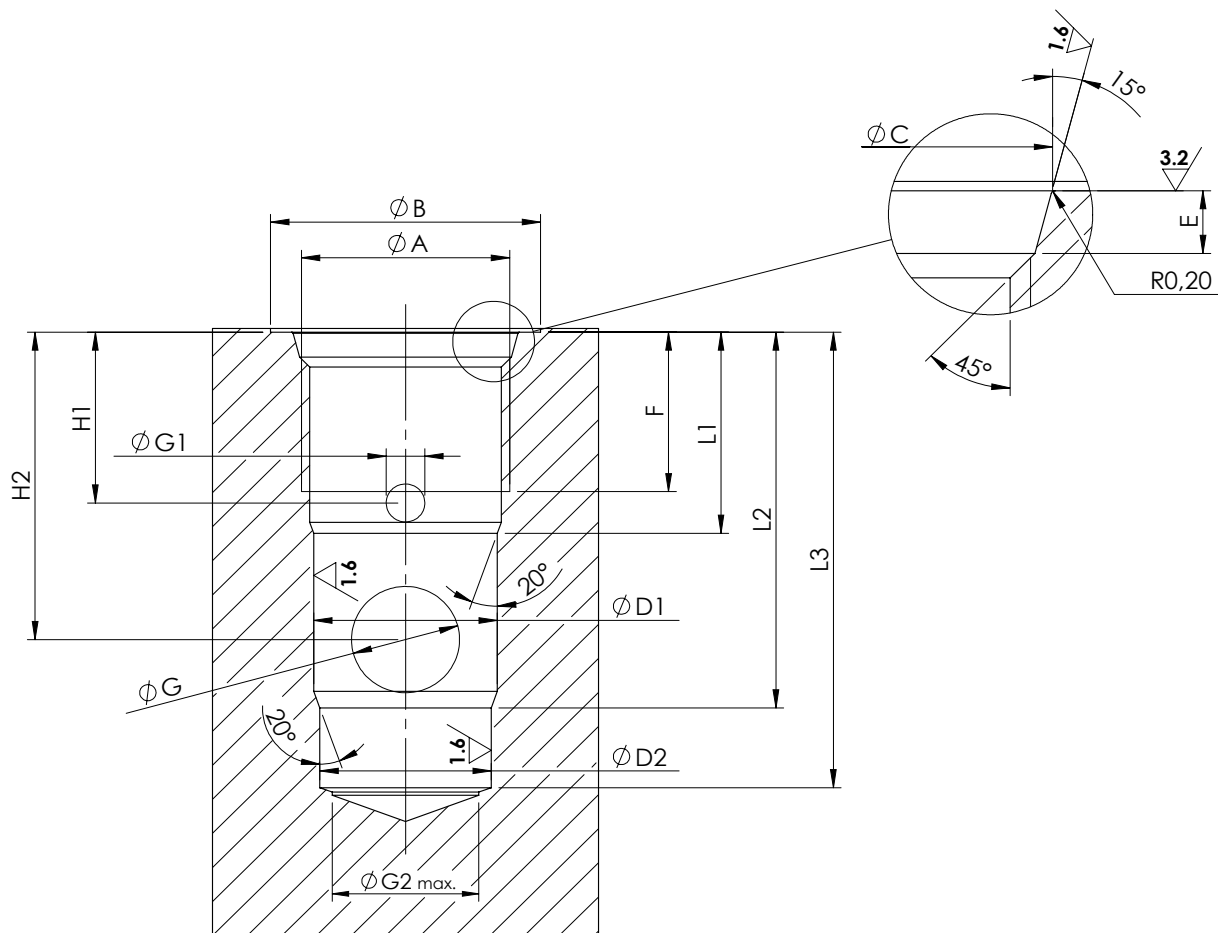

General tolerances : 0.03 mm

Ⓞ	0.03
⊥	0.02

	SAE-08-3C	SAE-10-3C	SAE-12-3C	SAE-16-3C	SAE-20-3C
A	3/4-16 UNF	7/8-14 UNF	1-1/16 12 UNF	1-5/16 12 UNF	1-5/8 12 UNF
B	26	30	35	42	48
C	20.6 ^{+0.1} ₀	23.9 ^{+0.1} ₀	29.2 ^{+0.1} ₀	35.5 ^{+0.1} ₀	43.5 ^{+0.1} ₀
D1	15.87 ^{+0.05} ₀	19.05 ^{+0.05} ₀	23.80 ^{+0.05} ₀	28.6 ^{+0.05} ₀	36.52 ^{+0.05} ₀
D2	14.27 ^{+0.05} ₀	17.47 ^{+0.05} ₀	22.22 ^{+0.05} ₀	25.42 ^{+0.05} ₀	33.35 ^{+0.05} ₀
E	2.6 ^{+0.3} ₀	2.6 ^{+0.3} ₀	3.3 ^{+0.3} ₀	3.3 ^{+0.3} ₀	3.4 ^{+0.3} ₀
F	12	13	21	16.5	20
G	8	14	14	15	28
G1	3	4	5	5	7
G2	12	15	19	24	30
H1	12.5	14	22.5	17.5	20
H2	26.5	31.5	40.5	38	50
L1	16	18	26.5	22	25.5
L2	32	40	49.5	47.5	65.5
L3	40	49	60	58	78

SAE-XX-3N

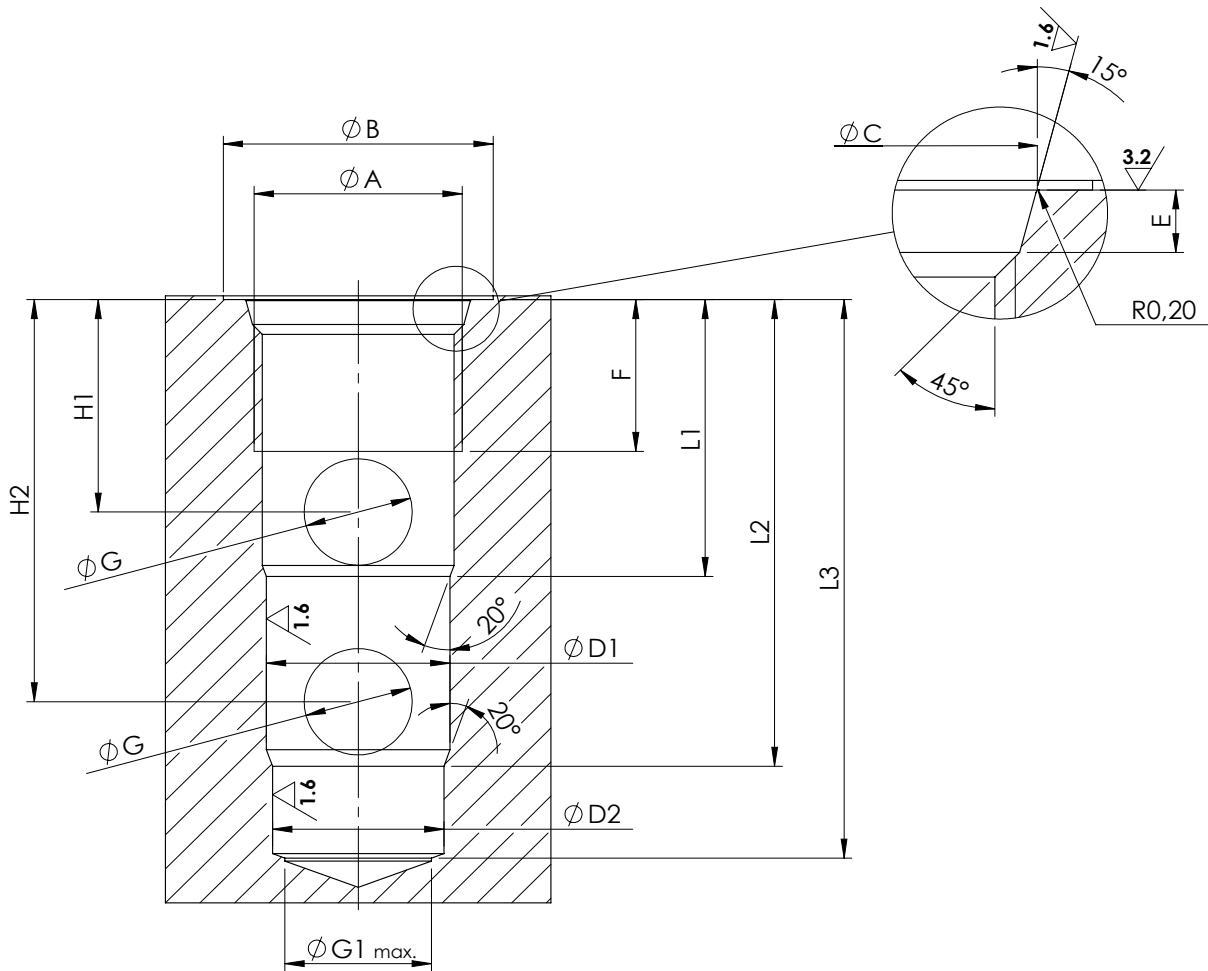

General tolerances : 0.03 mm

⊙	0.03
⊥	0.02

	SAE-08-3N	SAE-10-3N	SAE-12-3N	SAE-16-3N	SAE-20-3N
A	3/4-16 UNF	7/8-14 UNF	1-1/16 12 UNF	1-5/16 12 UNF	1-5/8 12 UNF
B	26	30	35	42	54
C	20.60 ^{+0.1} ₀	23.90 ^{+0.1} ₀	29.20 ^{+0.1} ₀	35.50 ^{+0.1} ₀	43.5 ^{+0.1} ₀
D1	15.87 ^{+0.05} ₀	17.47 ^{+0.05} ₀	23.80 ^{+0.05} ₀	28.60 ^{+0.05} ₀	36.52 ^{+0.05} ₀
D2	14.27 ^{+0.05} ₀	15.87 ^{+0.05} ₀	22.22 ^{+0.05} ₀	27.00 ^{+0.05} ₀	33.35 ^{+0.05} ₀
E	2.6 ^{+0.3} ₀	2.6 ^{+0.3} ₀	3.3 ^{+0.3} ₀	3.3 ^{+0.3} ₀	3.4 ^{+0.3} ₀
F	13	14	20	20	22
G	6	8	14	17	25
G1	12	15	19	24	30
-	-	-	-	-	-
H1	15	18	28	25.5	32
H2	29	34	53	54	72
L1	19.50	23.5	36.5	35.5	46
L2	33.50	39.50	61.50	64	86
L3	43	48.50	73	75	100

SAE-XX-4N

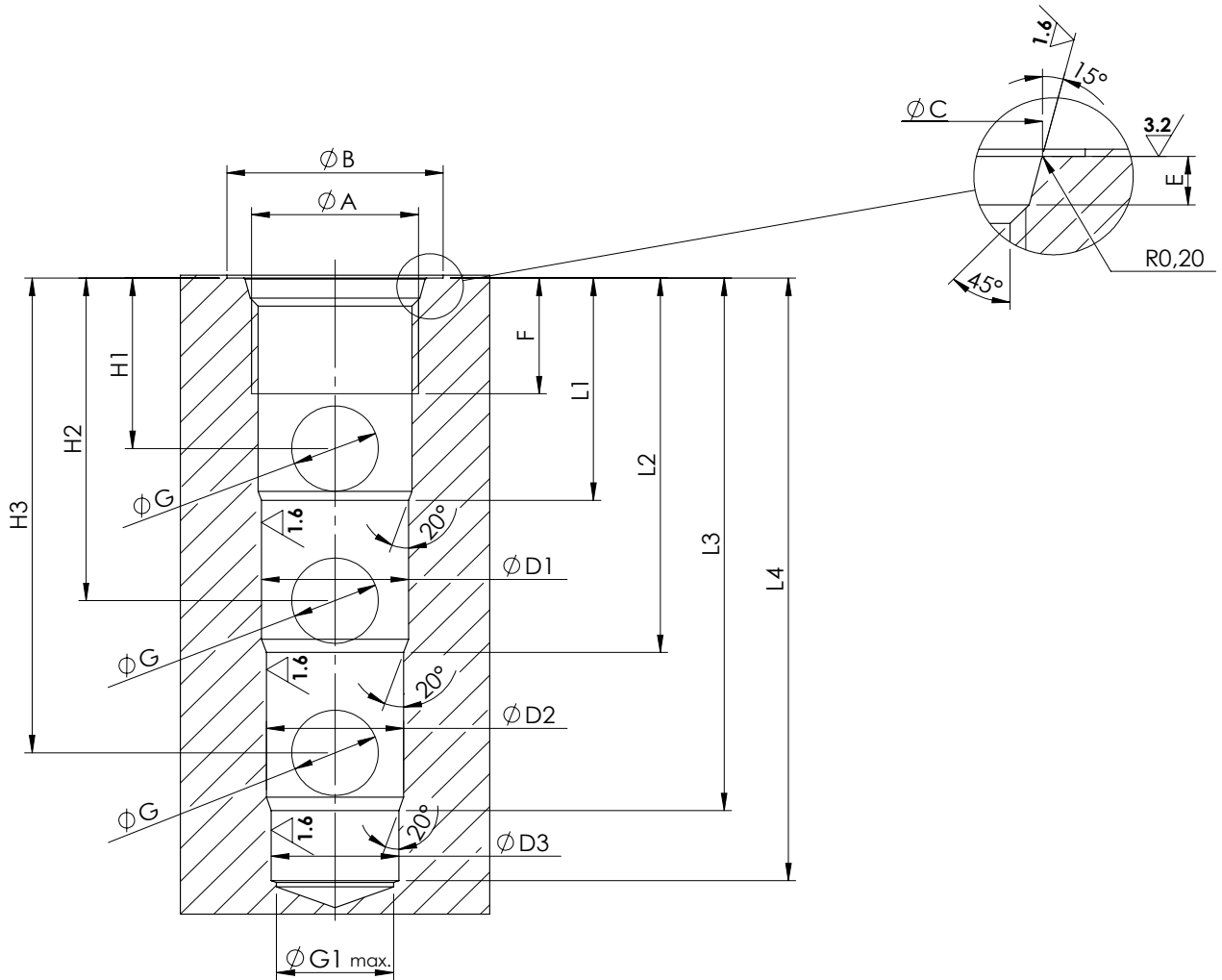

General tolerances: 0.03 mm

⊙	0.03
⊥	0.02

	SAE-08-4N	SAE-10-4N	SAE-12-4N	SAE-16-4N	SAE-20-4N
A	3/4-16 UNF	7/8-14 UNF	1-1/16 12 UNF	1-5/16 12 UNF	1-5/8 12 UNF
B	26	30	35	42	48
C	20.60 ^{+0.1} ₀	23.90 ^{+0.1} ₀	29.20 ^{+0.1} ₀	35.50 ^{+0.1} ₀	43.5 ^{+0.1} ₀
D1	15.87 ^{+0.05} ₀	19.05 ^{+0.05} ₀	23.80 ^{+0.05} ₀	28.60 ^{+0.05} ₀	36.52 ^{+0.05} ₀
D2	14.27 ^{+0.05} ₀	17.47 ^{+0.05} ₀	22.22 ^{+0.05} ₀	27.00 ^{+0.05} ₀	33.35 ^{+0.05} ₀
D3	12.7 ^{+0.05} ₀	15.87 ^{+0.05} ₀	20.62 ^{+0.05} ₀	25.42 ^{+0.05} ₀	31.75 ^{+0.05} ₀
E	2.6 ^{+0.3} ₀	2.6 ^{+0.3} ₀	3.3 ^{+0.3} ₀	3.3 ^{+0.3} ₀	3.4 ^{+0.3} ₀
F	13	15	19	20	22
G	6	8	14	16	25
G1	12	15	19	24	30
H1	15	18	28	25	32
H2	29	34	53	53.5	72
H3	43	50	78	82	114
L1	19.5	23.5	36.5	35.5	46
L2	33.5	39.5	61.5	64	87
L3	47.5	55.5	87.5	92.5	128.5
L4	56	64.5	99	104	142

SPECIAL CAVITIES

VP000005

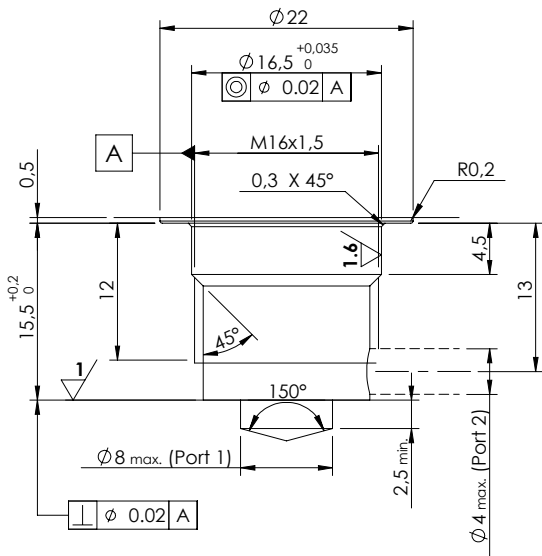

VP000006

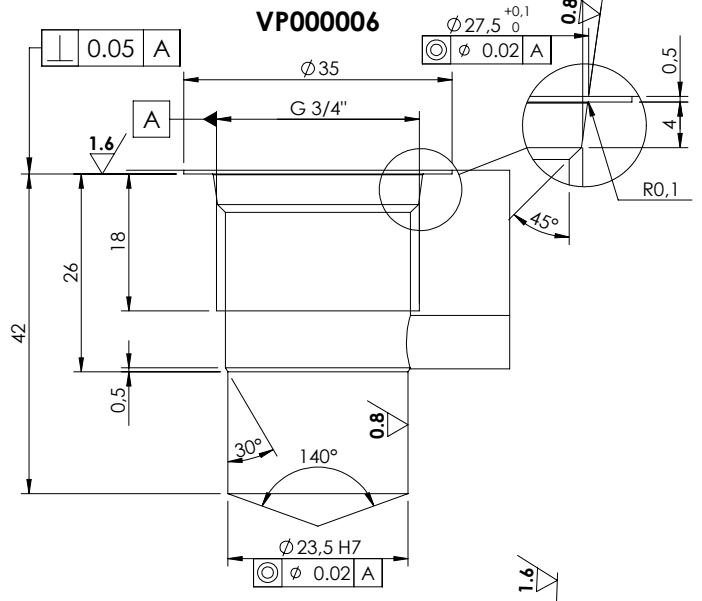

VP000008

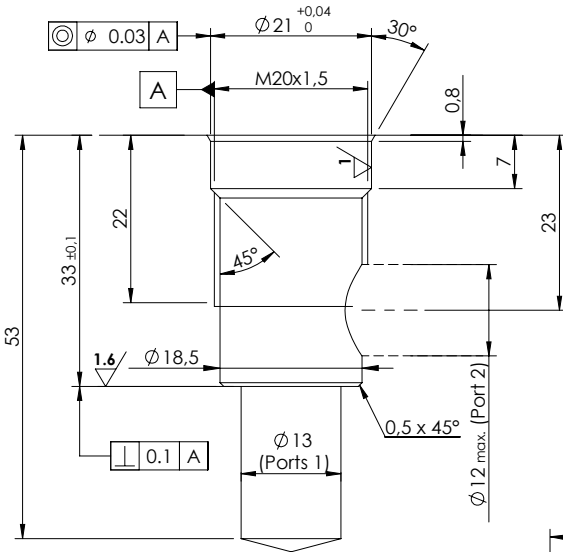

VP000013

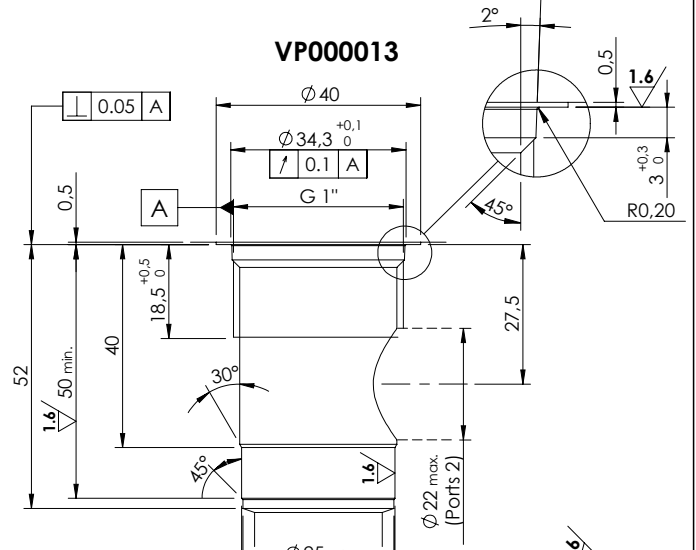

VP000015

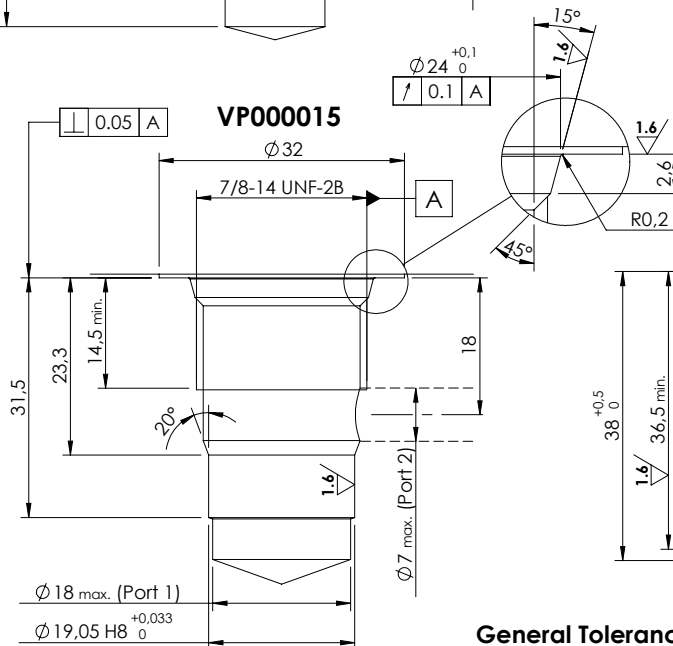

VP000016

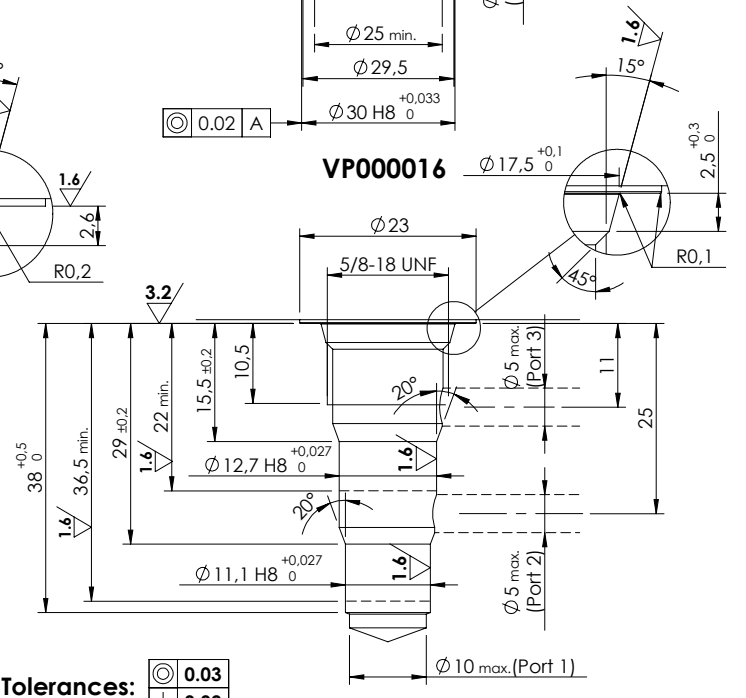

General Tolerances:

	0.03
	0.02

VP000018

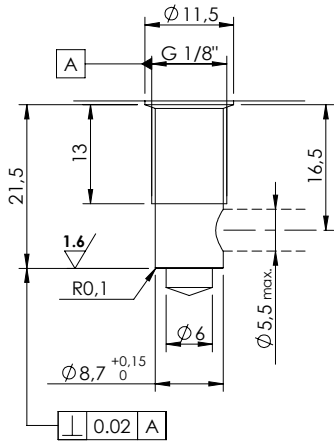

VP000028

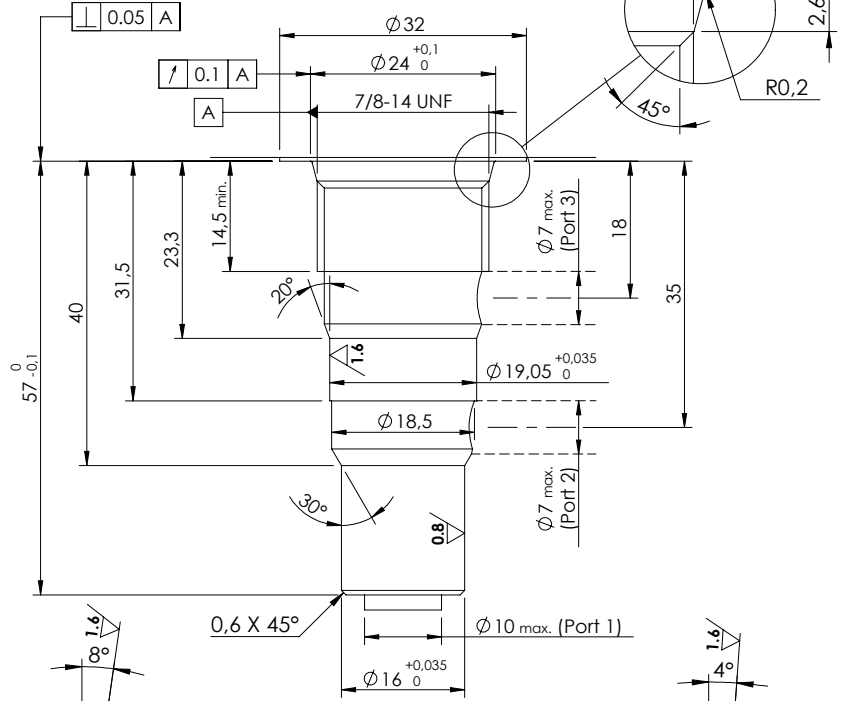

VP000038

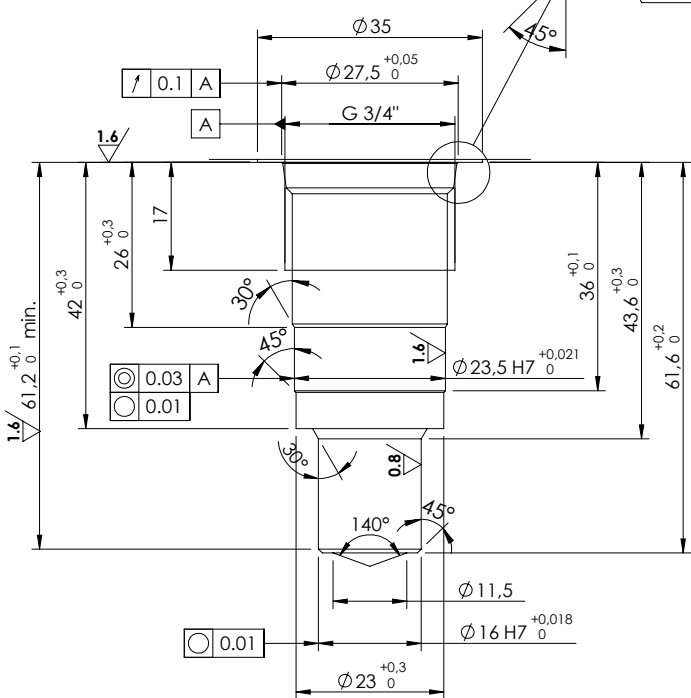

VP000057

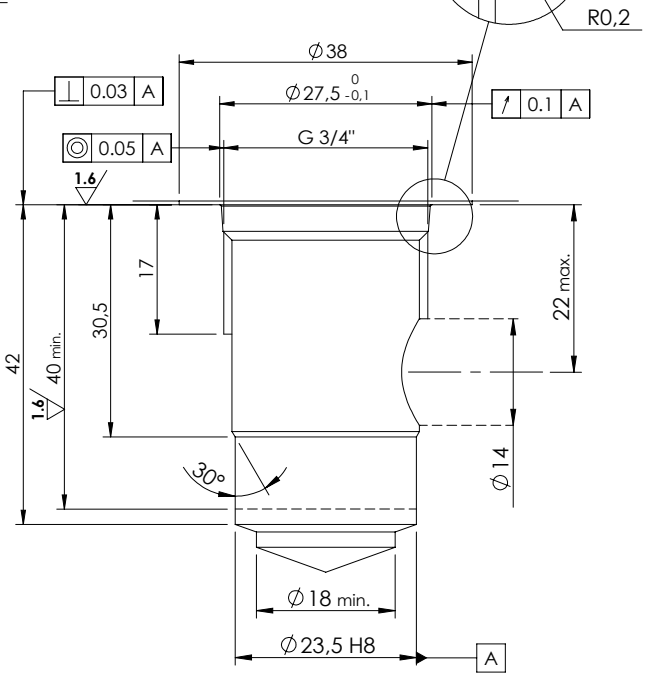

General Tolerances:

⊙	0.03
⊥	0.02

SPECIAL CAVITIES

VP000080

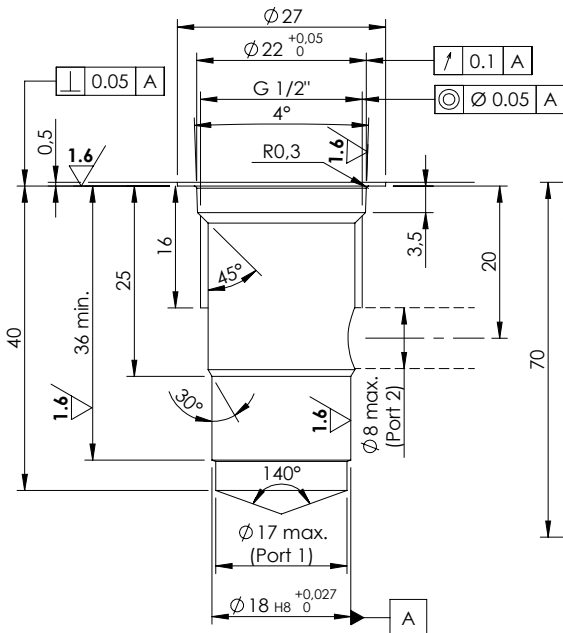

VP000086

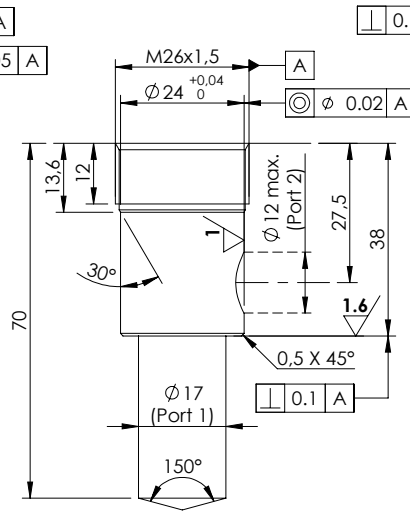

VP000096

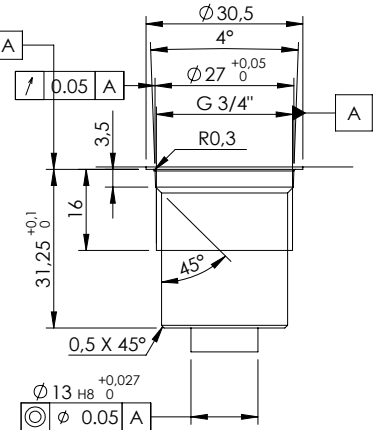

VP000098

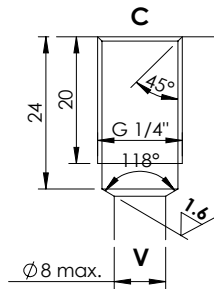

VP000120

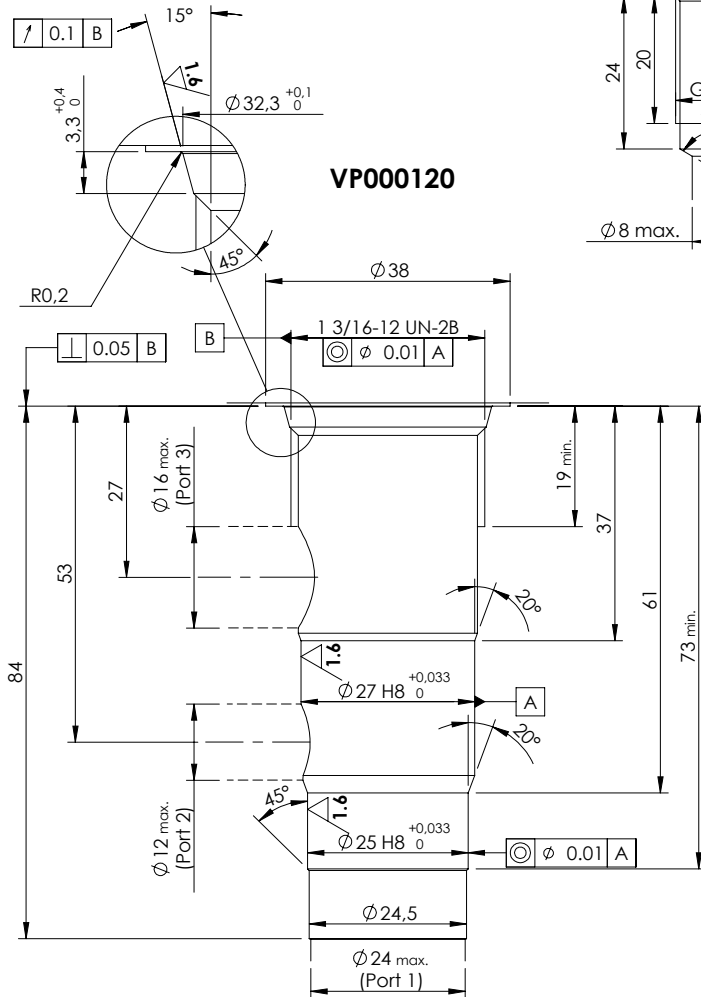

VP000121

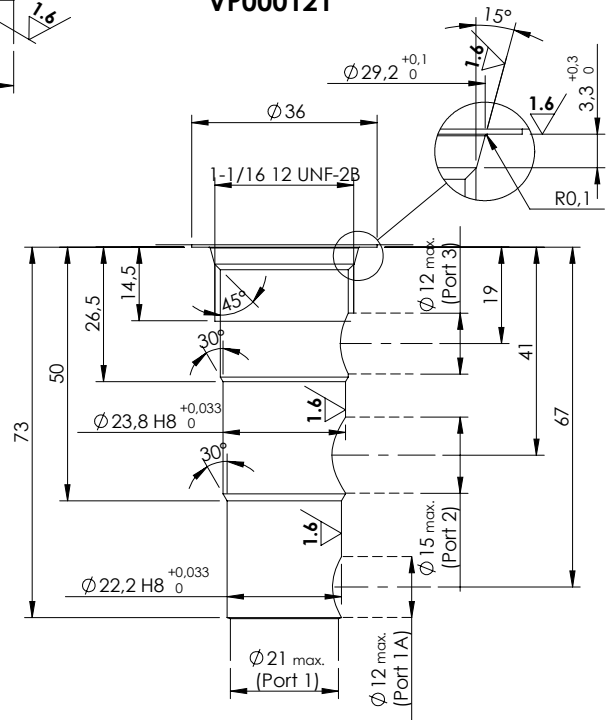

General Tolerances: $\text{◎} 0.03$
 $\text{⏏} 0.02$

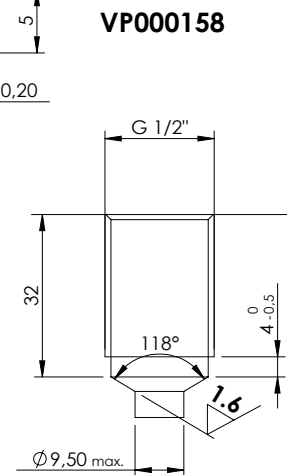
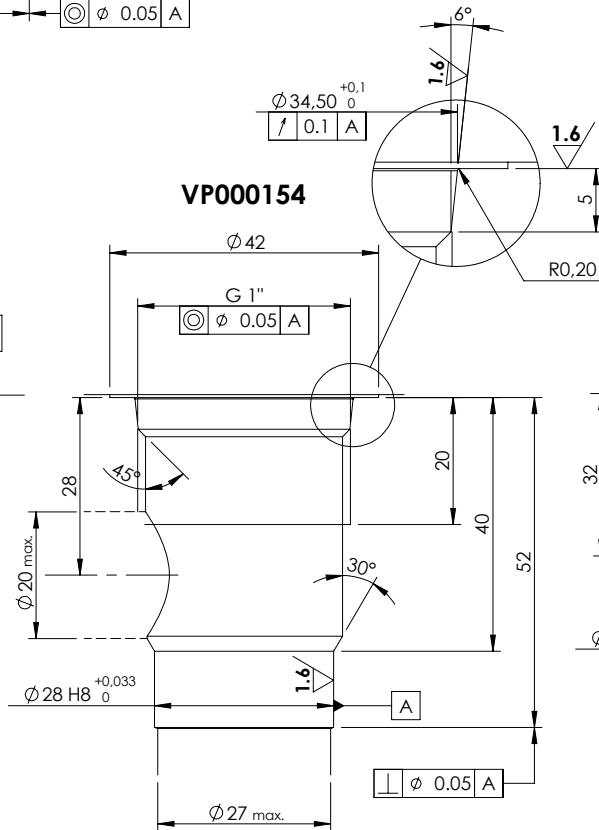
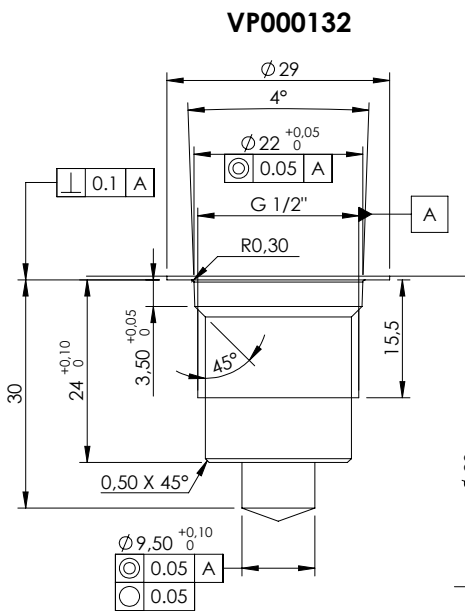
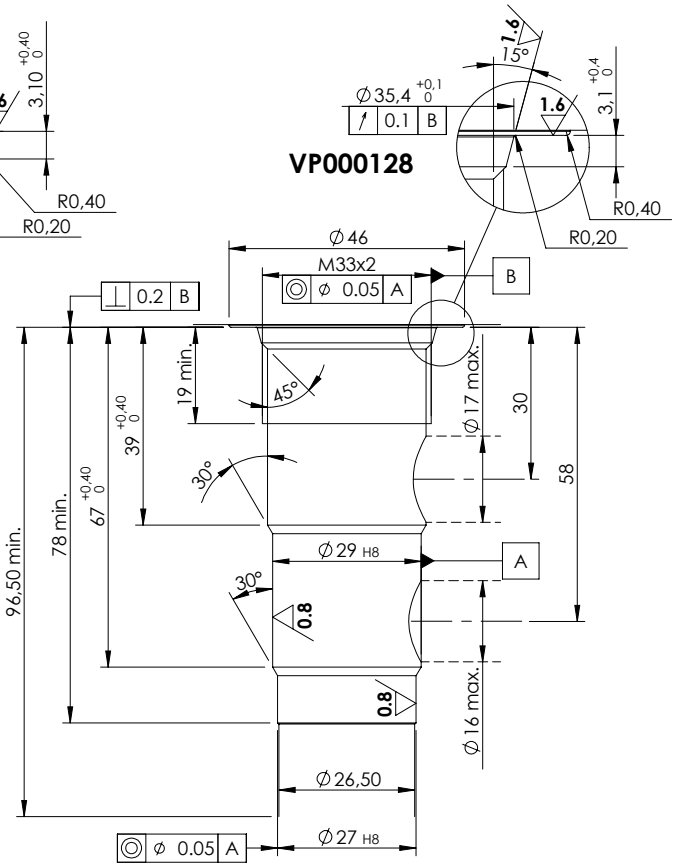
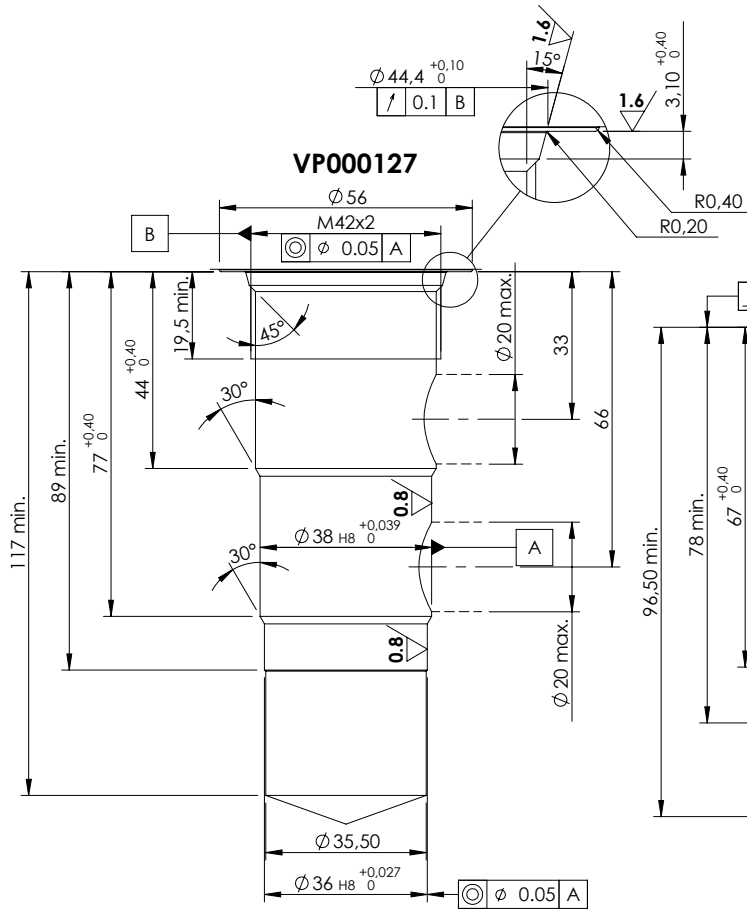

General Tolerances: $\sqrt{0.03}$
 $\sqrt{0.02}$

SPECIAL CAVITIES

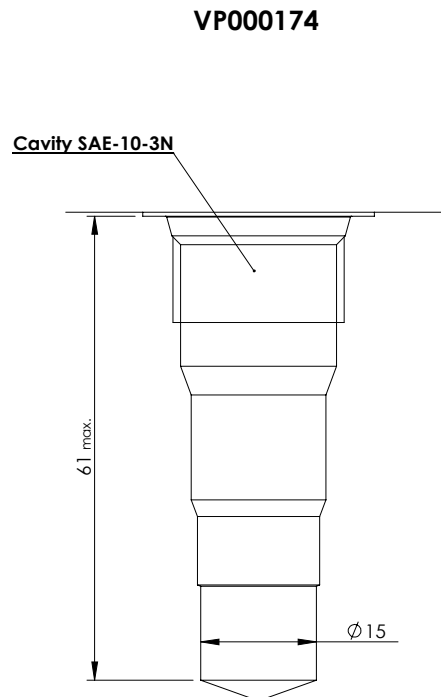
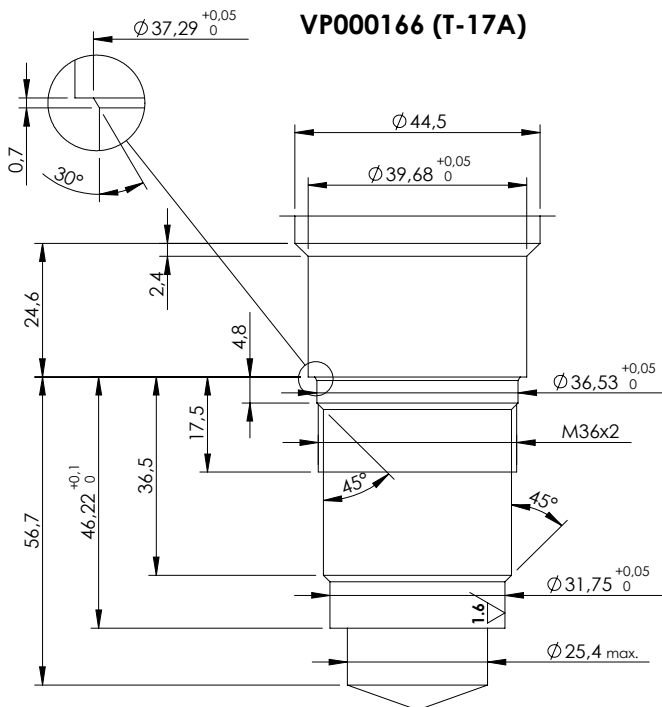
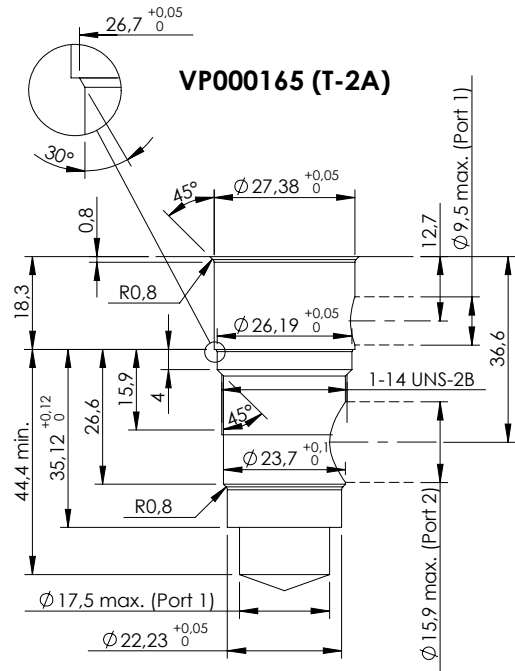
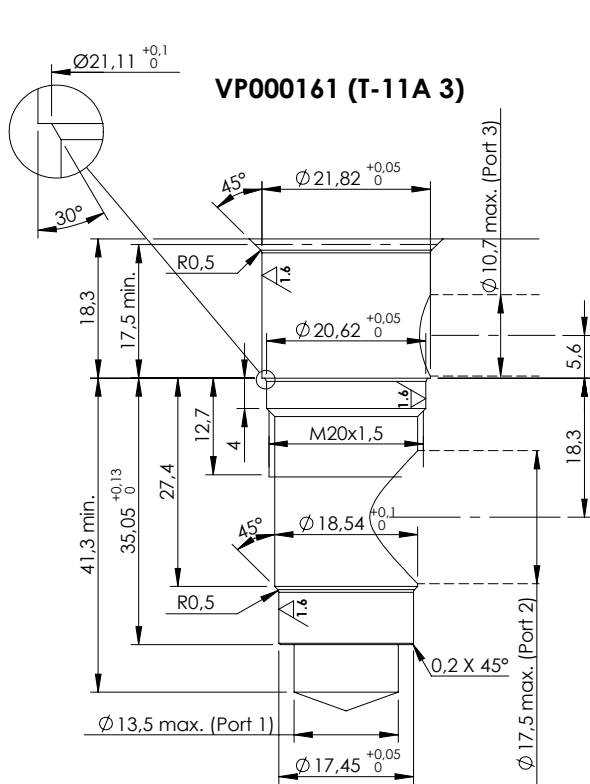

General Tolerances:

\varnothing	0.03
\perp	0.02

VP000178

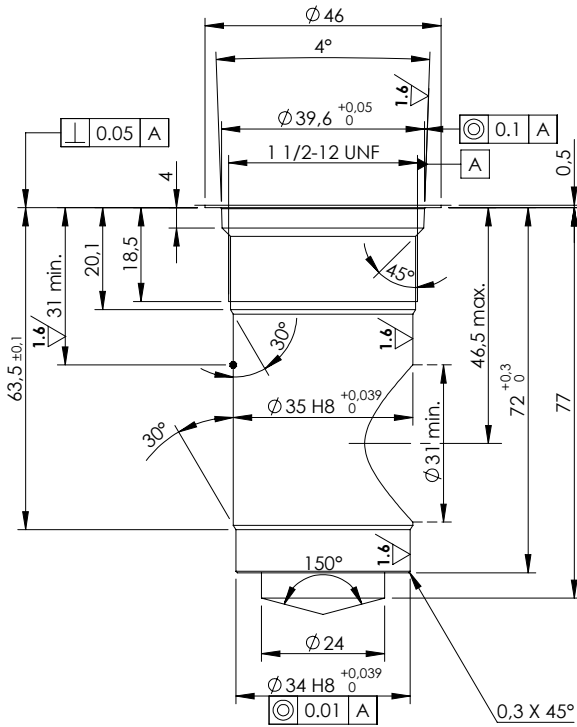

VP000180

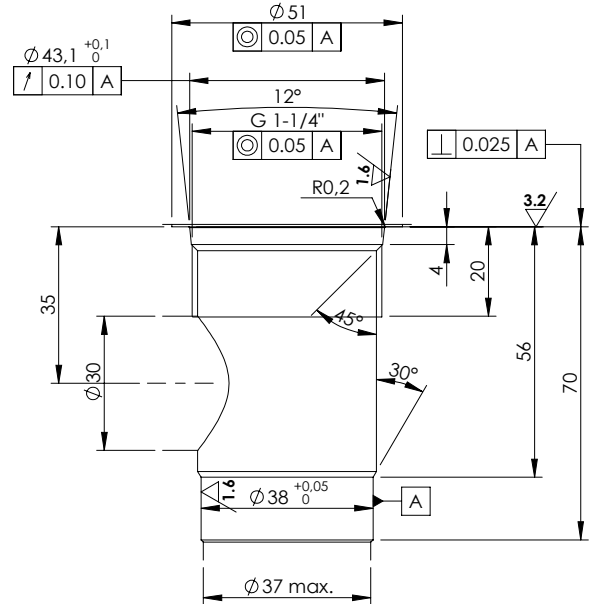

Cavity SAE-08-2N VP000193

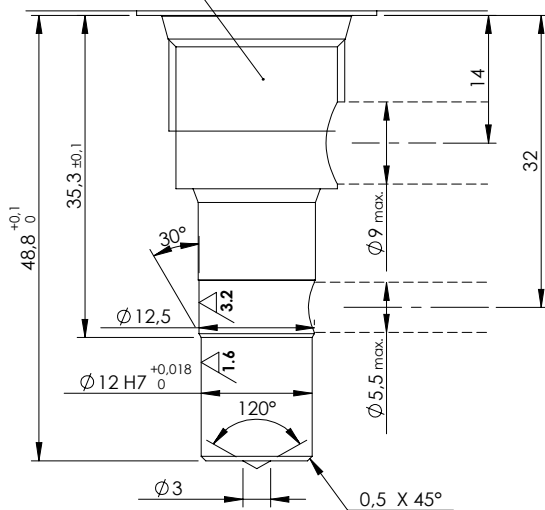

VP000198

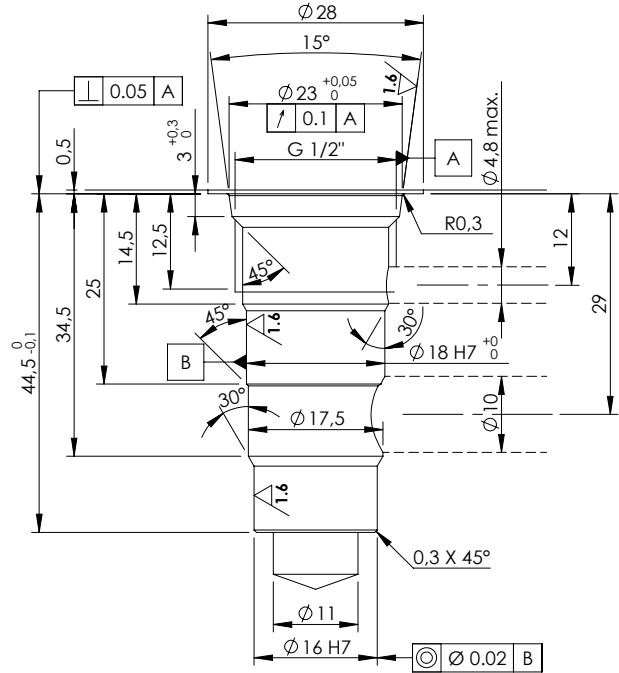

General Tolerances:

⊙	0.03
⊥	0.02

SPECIAL CAVITIES

VP000202

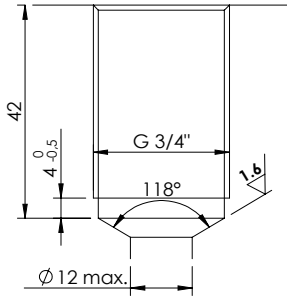

VP000204

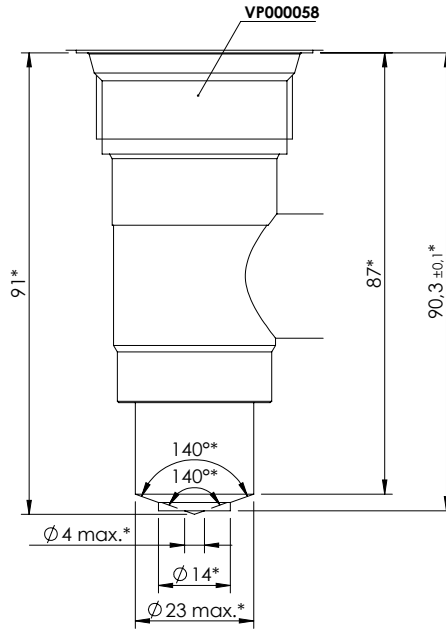

VP000216

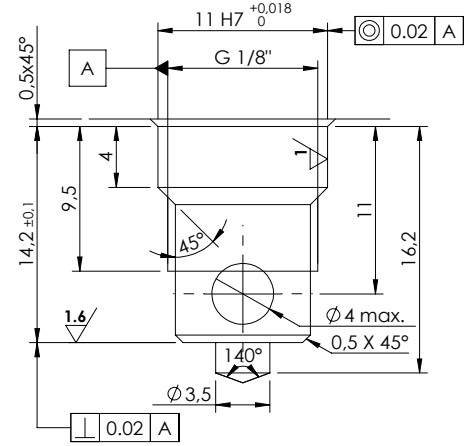

VP000249

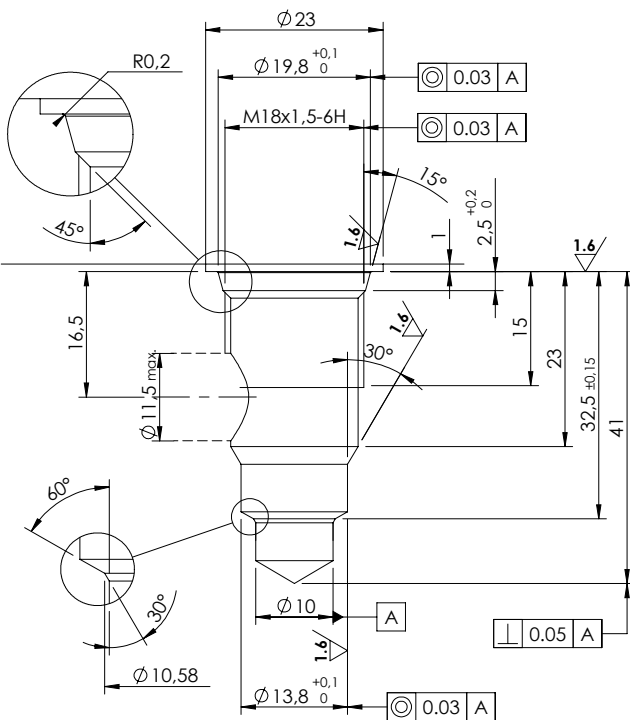

VP000250

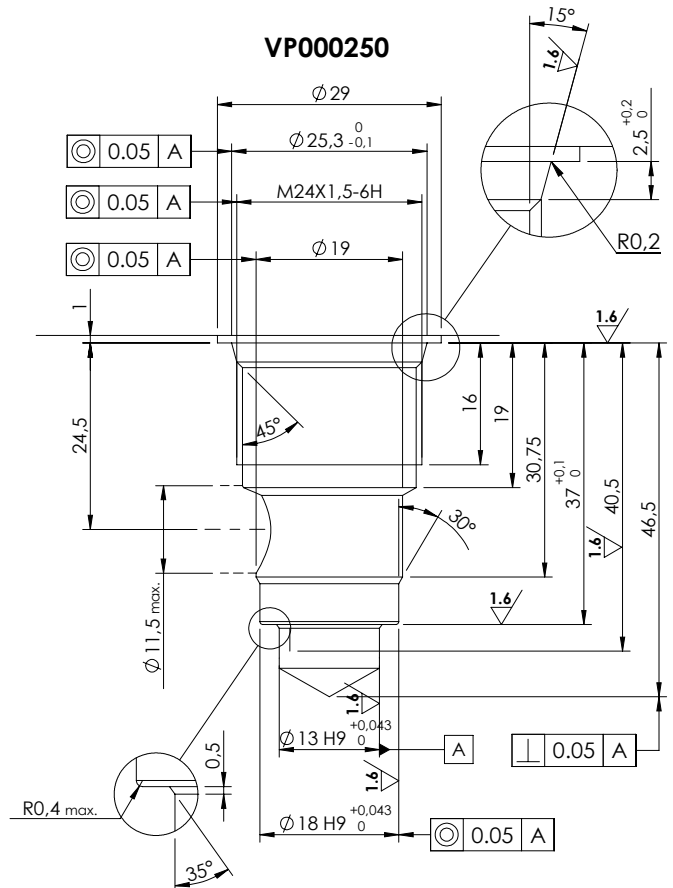

General Tolerances:

⊙	0.03
⊥	0.02

VP000307

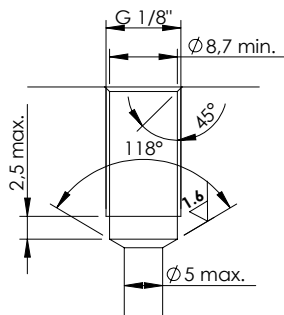

VP000309

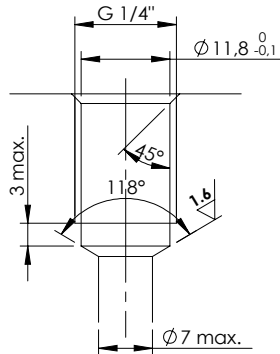

VP000310

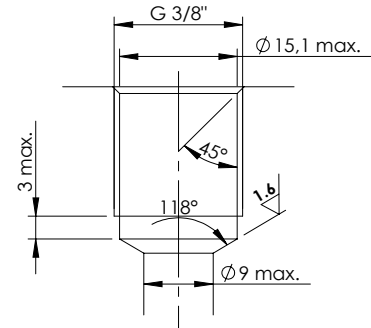

VP000311

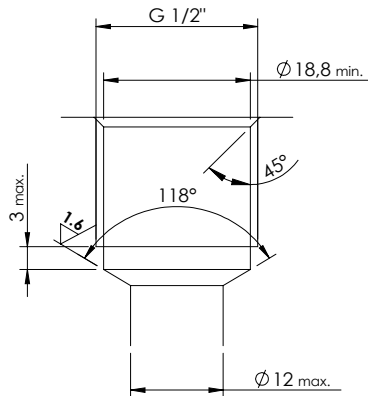

VP000312

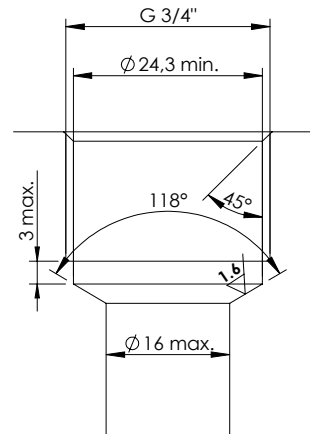

VP000314

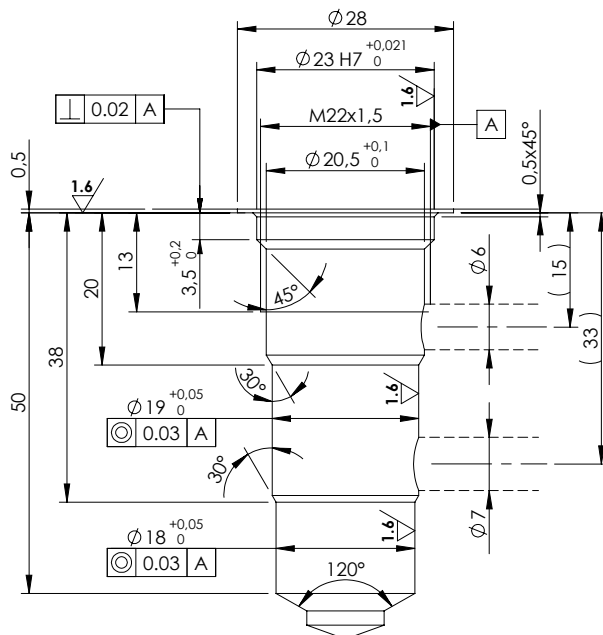

VP000330

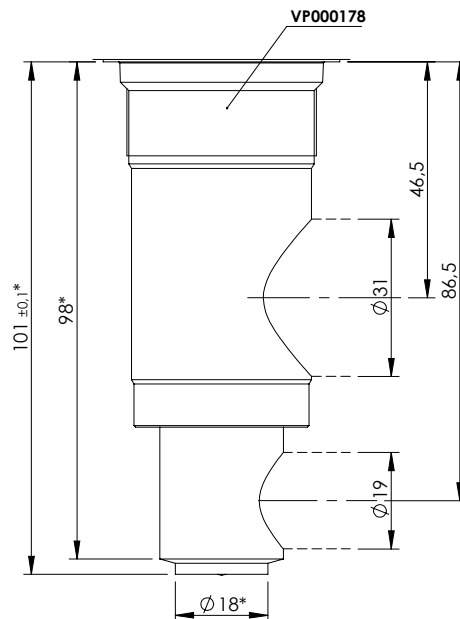

General Tolerances:

	0.03
	0.02

SPECIAL CAVITIES

VP000338

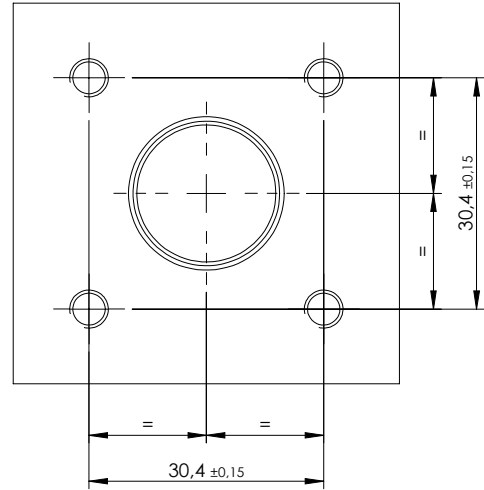
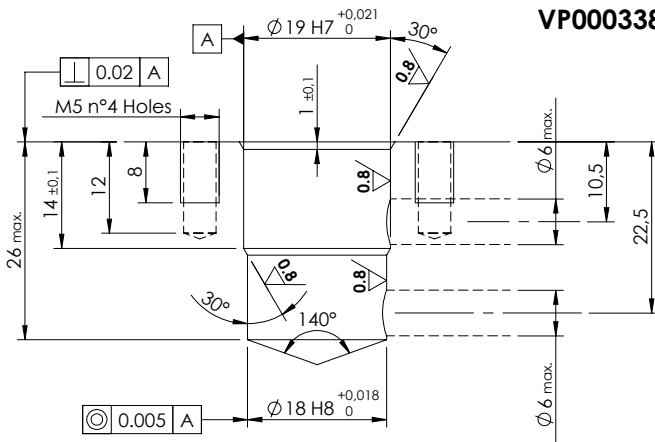

VP000371

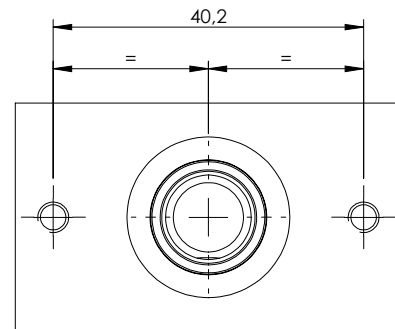
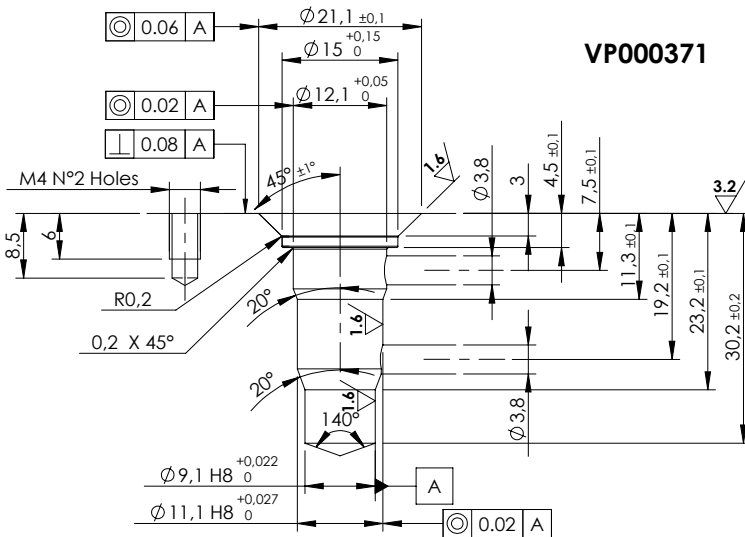

VP000388

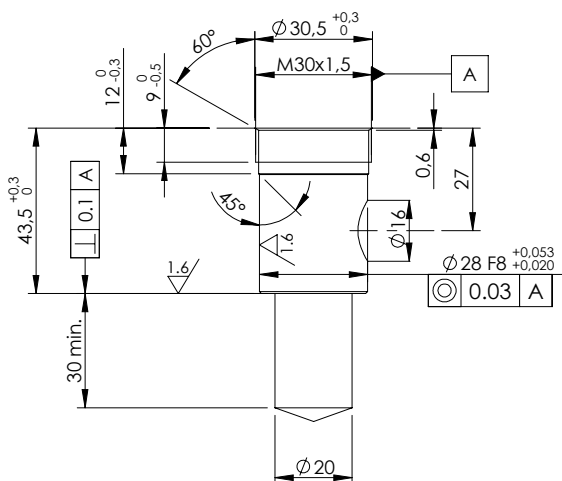

VP000445

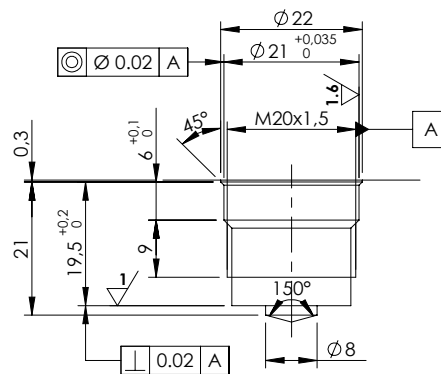

General Tolerances:

⊙	0.03
⊥	0.02

VP000555

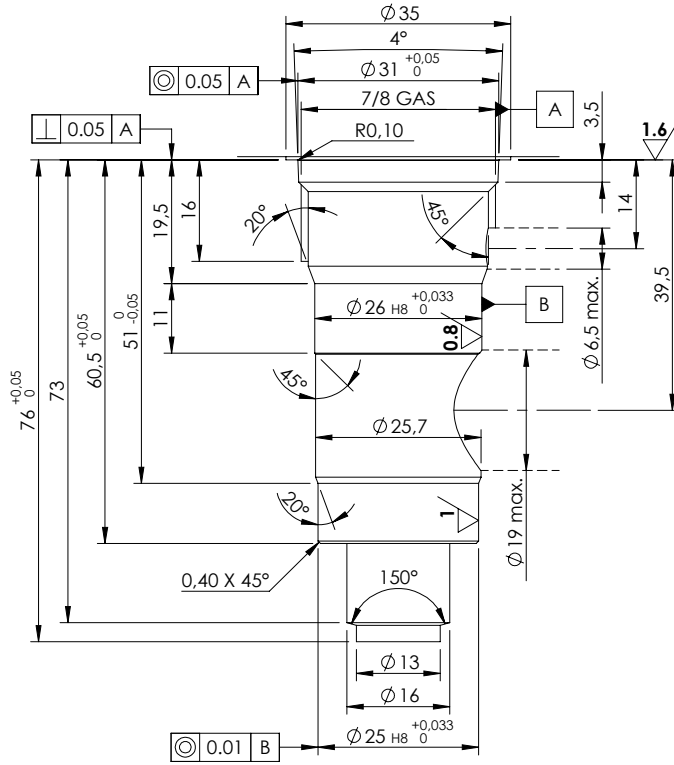

General Tolerances: $\text{Ra } 0.03$
 0.02

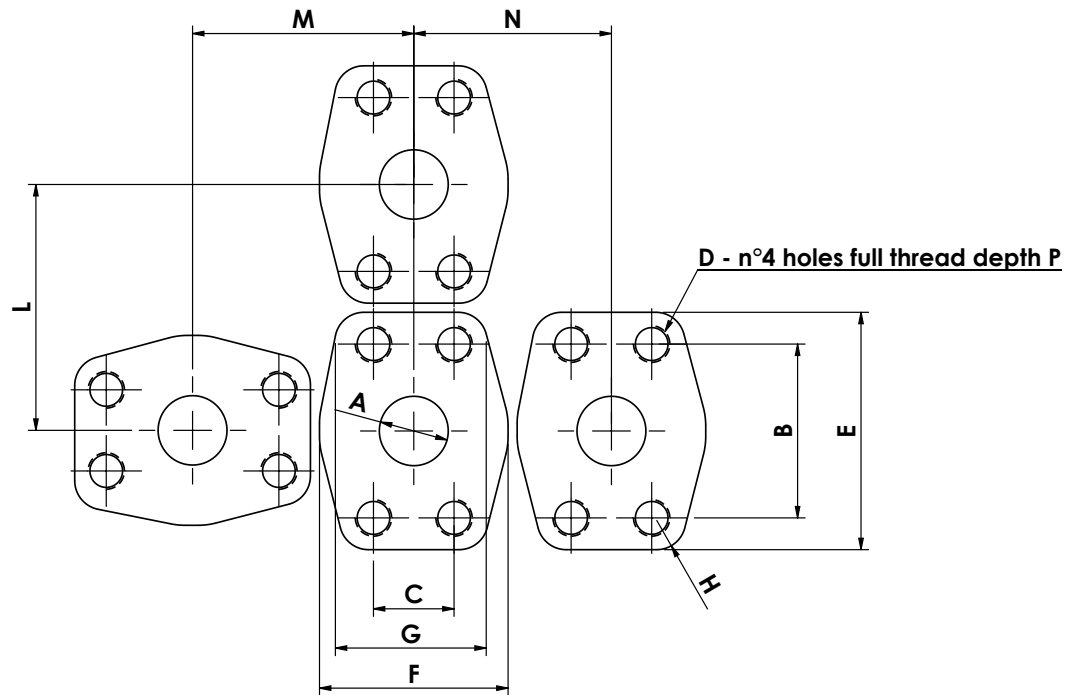

FLANGE SAE 3000 PSI (MEDIUM PRESSURE)

		1/2	3/4	1"	1" 1/4	1" 1/2
A	∅ max.	13	19	25,5	32	38
B	-	38,1	47,6	52,4	58,7	69,9
C	-	17,5	22,2	26,2	30,2	35,7
D	unc-2B	5/16-18	3/8-16	3/8-16	7/16-14	1/2-13
	metric	M8	M10	M10	M10	M12
E	-	54	65	70	79	94
F	-	46	52	59	73	83
G	min.	33	41	48	54	64
H	radius	8	9	9	10	12
L	min.	56	68	72	82	96
M	min.	52	61	67	78	90
N	min.	49	55	61	75	85
P	min. mm	24	22	22	28	27

FLANGE SAE 6000 PSI (HIGH PRESSURE)

		1/2	3/4	1"	1" 1/4	1" 1/2
A	∅ max.	13	19	25,5	32	38
B	-	40,50	50,80	57,2	66,7	79,4
C	-	18,2	23,80	27,8	31,80	36,50
D	unc-2B	5/16-18	3/8-16	7/16-14	1/2-13	5/8-11
	metric	M8	M10	M12	M14	M16
E	-	56	71	81	95	113
F	-	48	60	70	78	95
G	min.	38	48	54	60	70
H	radius	8	10	12	14	17
L	min.	59	75	84	99	116
M	min.	56	70	80	90	108
N	min.	53	66	75	83	101
P	min. mm	21	24	27	25	35



ATLANTIC
Fluid Tech

SECTION 3

Sequence Valves



1800-OILSOL
1800-645765

<https://oilsolutions.com.au/>

sales@oilsolutions.com.au

SECTION 3

SEQUENCE VALVES



Hydraulic scheme	Valve description	Valve type	Rated flow (l/min)	Max. pressure (bar)	Installation	Main port size or cavity type	Page
	KPSN-030-DPNA	Direct acting, stabilized piston, not compensated	30	350	In line	G3/8"	3.01.010
	KPSN-030-DPNA	Direct acting, stabilized piston, not compensated	30	350	In line	G1/2"	3.01.020
	CPSN-060-DPGD	Direct acting, with anti-cavitation	60	420	Sleve	G3/8"	3.01.030
	KPST-030-DPNA	Direct acting, stabilized piston, compensated	30	350	In line	G3/8"	3.02.040
	KPST-030-DPNA	Direct acting, stabilized piston, compensated	30	350	In line	G1/2"	3.02.050
	CPST-060-DHLD	Differential, compensated	60	350	Sleve	G3/8"	3.02.060
	CPST-100-DHLD	Differential, compensated	100	350	Sleve	G1/2"	3.02.070
	KPEN-020-DPLD	Direct acting, solenoid by-pass	20	350	In line	G1/4"	3.03.080

SEQUENCE VALVE IN BODY

KPSN-030-DPNA

**DIRECT ACTING
STABILIZED PISTON
NOT COMPENSATED**

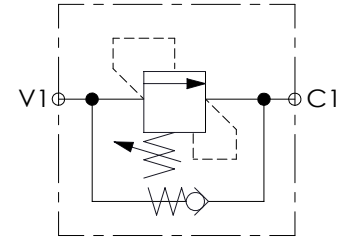
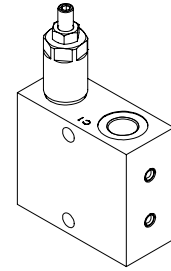
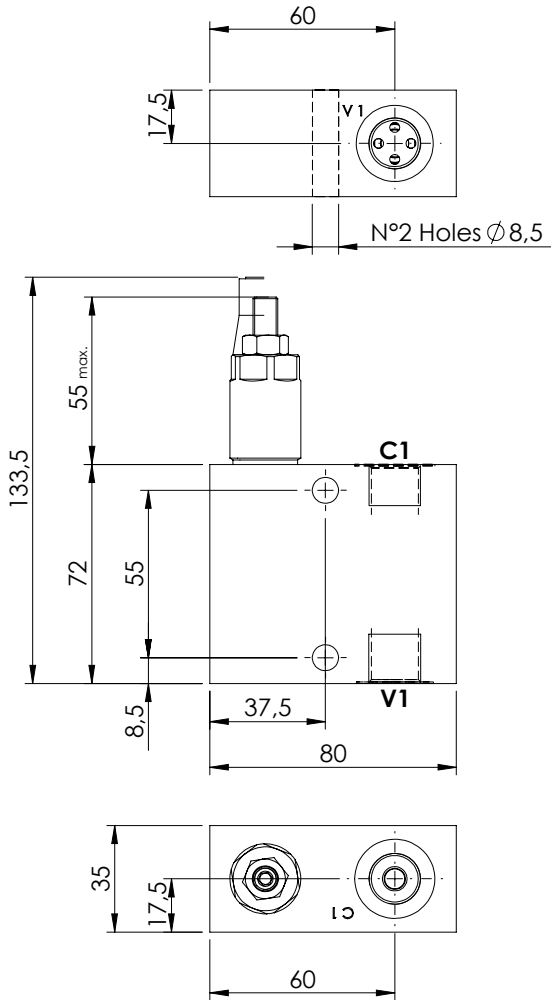

SPECIFICATIONS

Max. operating pressure:	350 bar
Rated flow:	30 l/min
Manifold:	Aluminium
Weight:	0,65 kg

SEALING CAP

Ordering code:
AT000020

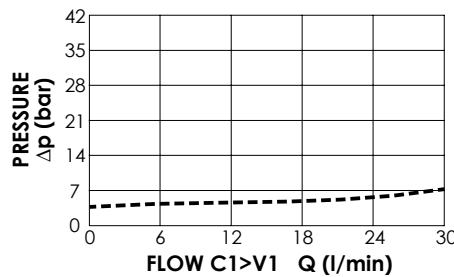
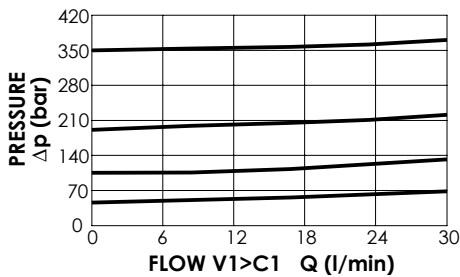
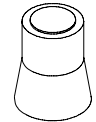

ORDERING CODES

Quick code	Description	Main ports size	Standard setting (bar, Q=5 l/min)	Adjustm. range (bar)	Pressure increase (bar/turn)
KP000036	KPSN-030-DPNA-HN-G38-N350	C1, V1: G 3/8"	350	100-350	91
KP000033	KPSN-030-DPNA-HN-G38-N200	C1, V1: G 3/8"	200	50-210	42
KP000035	KPSN-030-DPNA-HN-G38-N100	C1, V1: G 3/8"	100	30-100	20
KP000034	KPSN-030-DPNA-HN-G38-N050	C1, V1: G 3/8"	50	10-50	10

SEQUENCE VALVE IN BODY

KPSN-030-DPNA

**DIRECT ACTING
STABILIZED PISTON
NOT COMPENSATED**

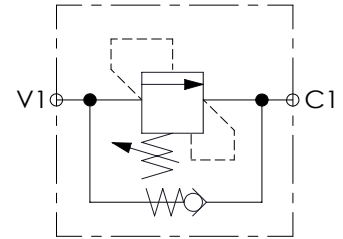
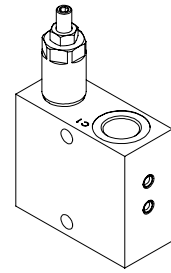
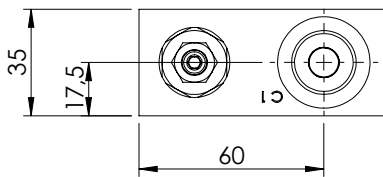
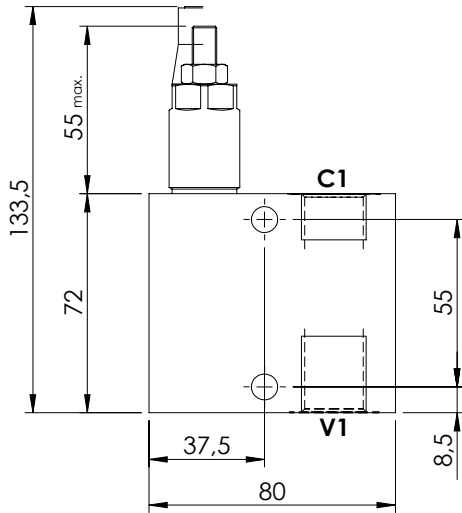
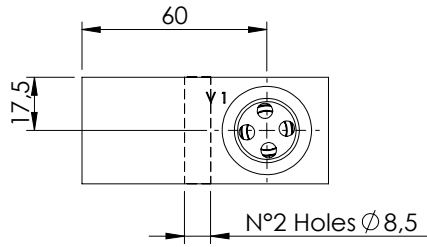

SPECIFICATIONS

Max. operating pressure:	350 bar
Rated flow:	30 l/min
Manifold:	Aluminium
Weight:	0,64 kg

SEALING CAP

Ordering code:
AT000020

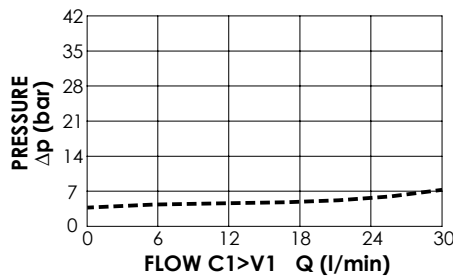
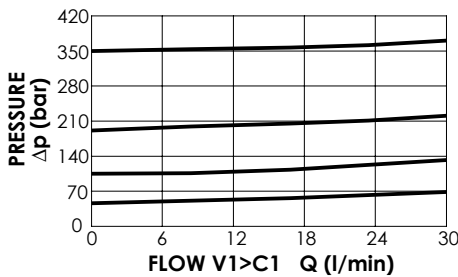
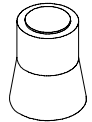

ORDERING CODES

Quick code	Description	Main ports size	Standard setting (bar, Q=5 l/min)	Adjustm. range (bar)	Pressure increase (bar/turn)
KP000061	KPSN-030-DPNA-HN-G12-N350	C1, V1: G 1/2"	350	100-350	91
KP000062	KPSN-030-DPNA-HN-G12-N200	C1, V1: G 1/2"	200	50-210	42
KP000060	KPSN-030-DPNA-HN-G12-N100	C1, V1: G 1/2"	100	30-100	20
KP000063	KPSN-030-DPNA-HN-G12-N050	C1, V1: G 1/2"	50	10-50	10

SEQUENCE SLEEVE VALVE

CPSN-060-DPGD

DIRECT ACTING
WITH ANTI-CAVITATION
POPET TYPE

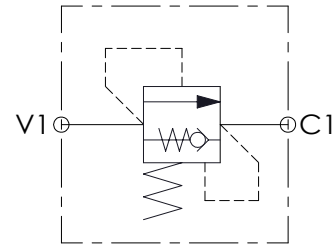
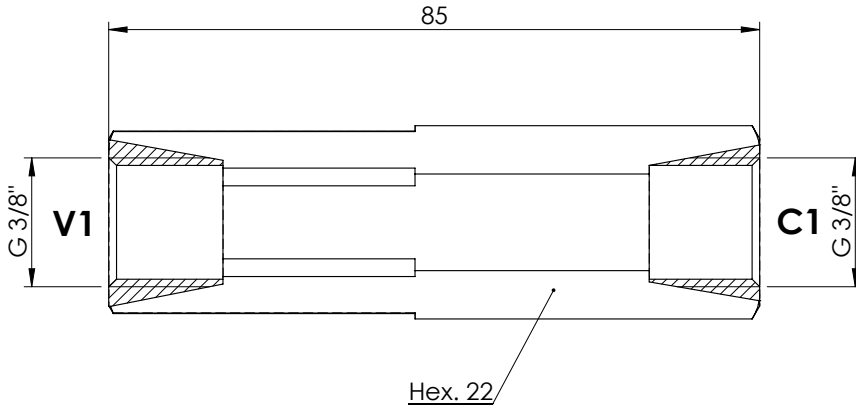
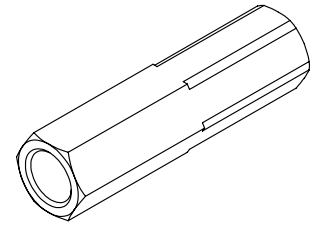

SPECIFICATIONS

Max. operating pressure:	350 bar
Rated flow:	60 l/min
Ports:	G 3/8"
Weight:	0.19 kg
Leakage:	1 cm ³ /min to 80% of nominal set point
Manifold:	Steel body

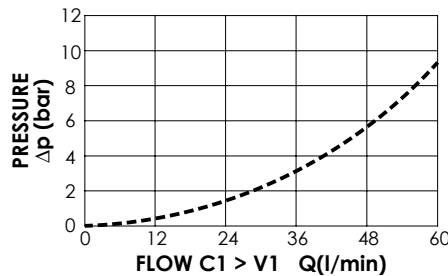
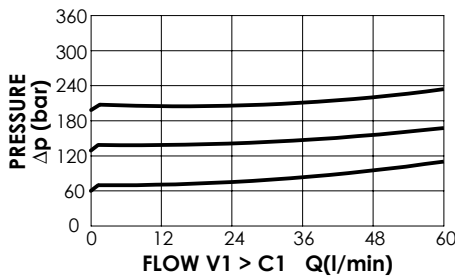

ORDERING CODES

Quick code	Spring range 20-70 bar setting (Q=1 l/min)	Quick code	Spring range 70-130 bar setting (Q=1 l/min)	Quick code	Spring range 130-210 bar setting (Q=1 l/min)
CP000194	20	CP000203	80	CP000210	140
CP000197	30	CP000204	90	CP000211	150
CP000198	40	CP000205	100	CP000212	160
CP000199	50	CP000206	110	CP000213	170
CP000200	60	CP000207	120	CP000214	180
CP000201	70	CP000208	130	CP000215	190
				CP000216	200
				CP000217	210

SEQUENCE VALVE IN BODY

KPST-030-DPNA

**DIRECT ACTING
STABILIZED PISTON
COMPENSATED**

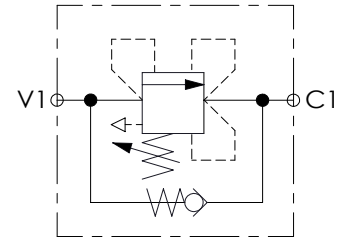
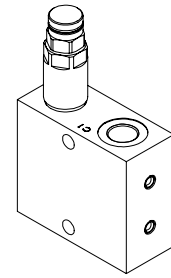
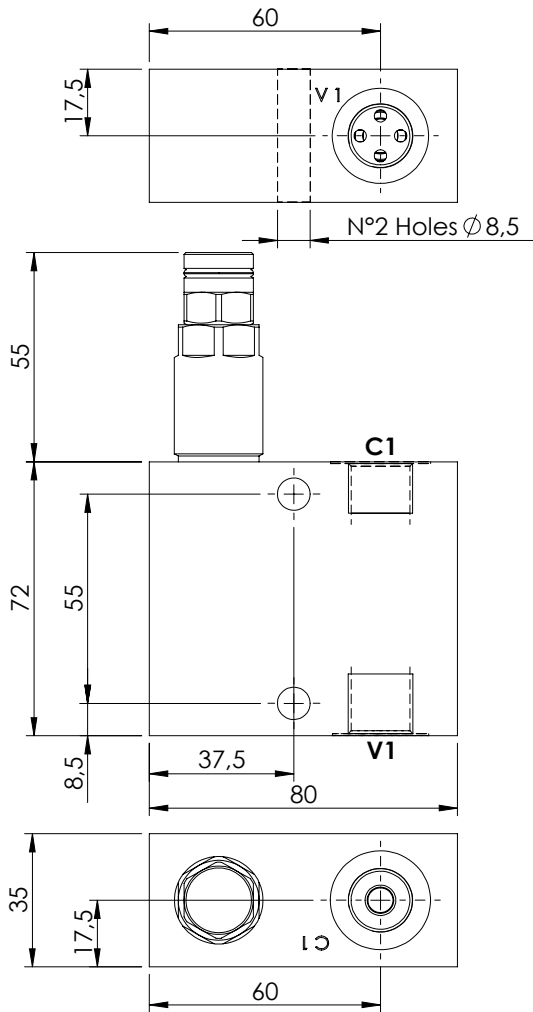

SPECIFICATIONS

Max. operating pressure:	350 bar
Rated flow:	30 l/min
Manifold:	Aluminium
Weight:	0,67 kg

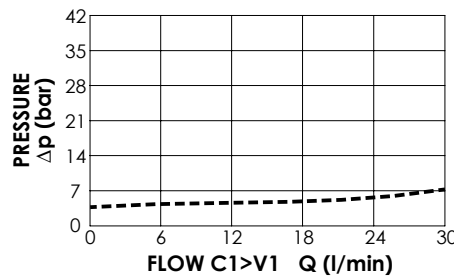
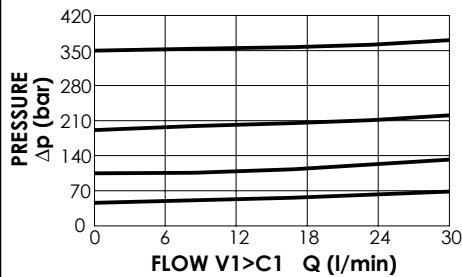

ORDERING CODES

Quick code	Description	Main ports size	Standard setting (bar, Q=5 l/min)	Adjustm. range (bar)	Pressure increase (bar/turn)
KP000079	KPST-030-DPNA-HN-G38-N350	C1, V1: G 3/8"	350	100-350	91
KP000080	KPST-030-DPNA-HN-G38-N200	C1, V1: G 3/8"	200	50-210	42
KP000081	KPST-030-DPNA-HN-G38-N100	C1, V1: G 3/8"	100	30-100	20
KP000082	KPST-030-DPNA-HN-G38-N050	C1, V1: G 3/8"	50	10-50	10

SEQUENCE VALVE IN BODY

KPST-030-DPNA

**DIRECT ACTING
STABILIZED PISTON
COMPENSATED**

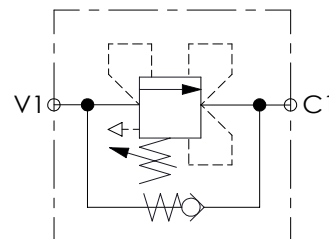
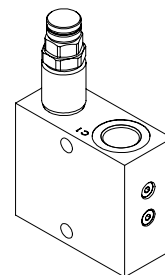
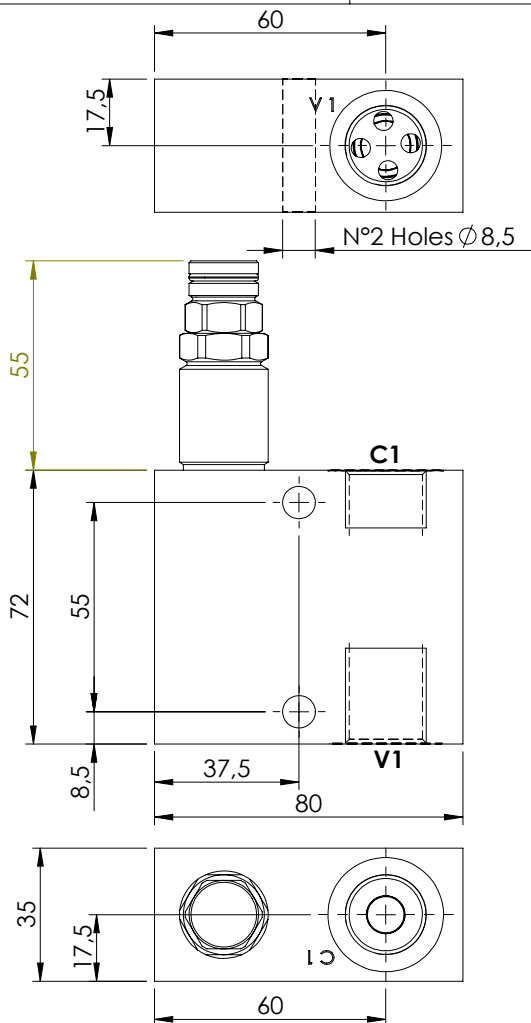

SPECIFICATIONS

Max. operating pressure:	350 bar
Rated flow:	30 l/min
Manifold:	Aluminium
Weight:	0,67 kg

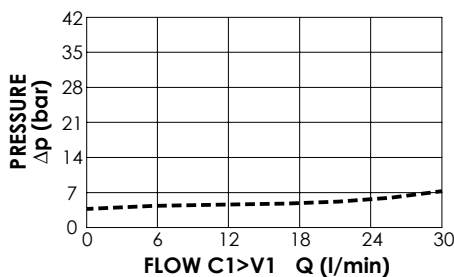
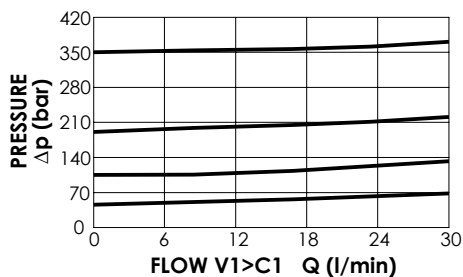

ORDERING CODES

Quick code	Description	Main ports size	Standard setting (bar, Q=5 l/min)	Adjustm. range (bar)	Pressure increase (bar/turn)
KP000083	KPST-030-DPNA-HN-G12-N350	C1,V1 : G 1/2"	350	100-350	91
KP000084	KPST-030-DPNA-HN-G12-N200	C1,V1 : G 1/2"	200	50-210	42
KP000085	KPST-030-DPNA-HN-G12-N100	C1,V1 : G 1/2"	100	30-100	20
KP000086	KPST-030-DPNA-HN-G12-N050	C1,V1 : G 1/2"	50	5-50	10

SEQUENCE VALVE

CPST-060-DHLD

DIFFERENTIAL AREA
COMPENSATED

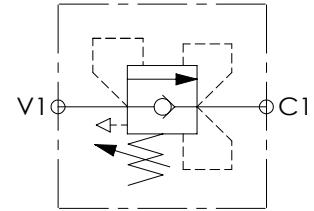
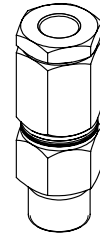
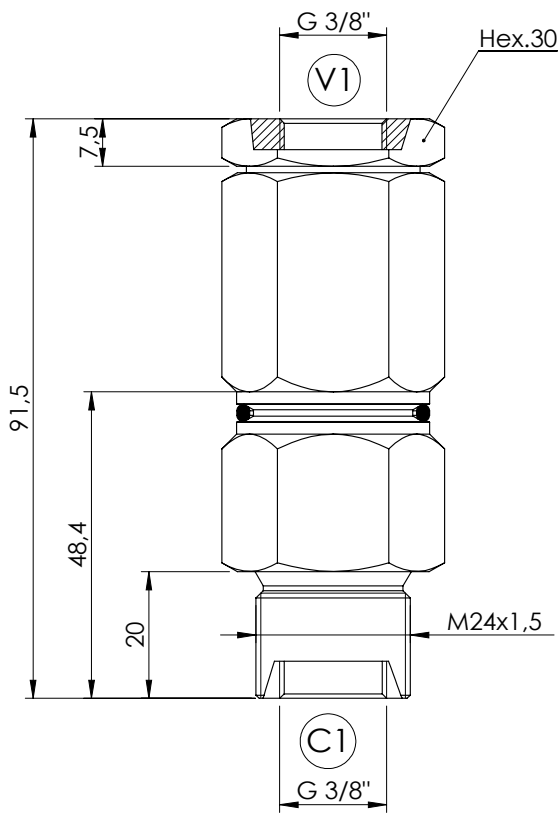

SPECIFICATIONS

Max. operating pressure:	350 bar
Rated flow:	60 l/min
Body:	Steel
Weight:	0,39 kg

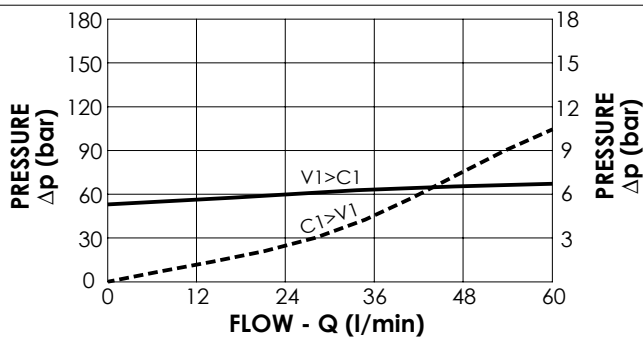

ORDERING CODES

Quick code	Description	Port size	Standard setting (bar, Q=5 l/min)	Adjust. range (bar)	Pressure increase (bar/turn)
CP000091	CPST-060-DHLD-GN-G38-N100	V1,C1 : G 3/8"	100	50-140	26
CP000435	CPST-060-DHLD-GN-G38-N120	V1,C1 : G 3/8"	120	50-140	26

SEQUENCE VALVE

CPST-100-DHLD

**DIFFERENTIAL AREA
POPET TYPE
COMPENSATED**

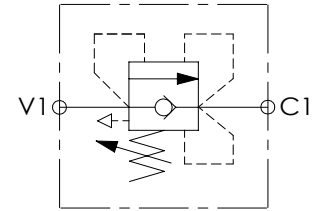
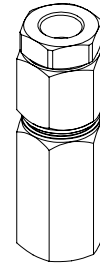
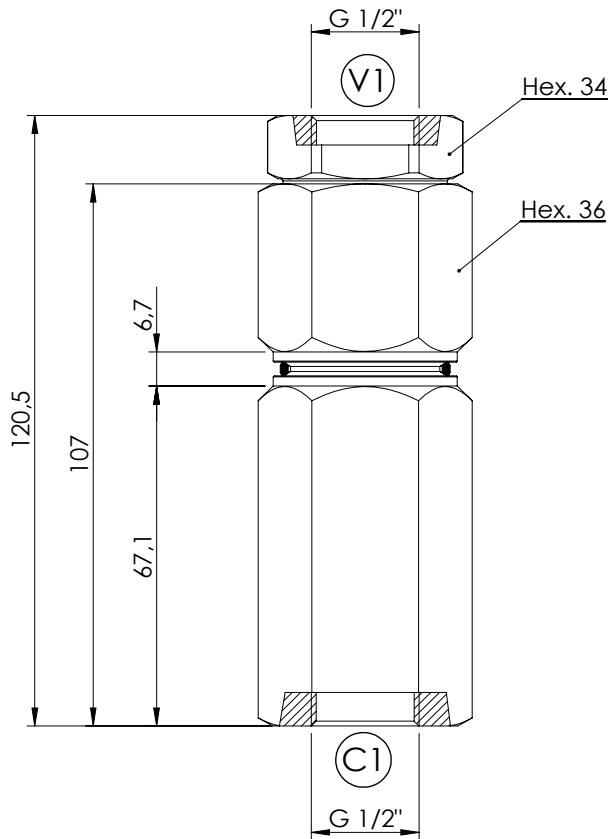

SPECIFICATIONS

Max. operating pressure:	350 bar
Rated flow:	100 l/min
Body:	Steel
Weight:	0,82 kg

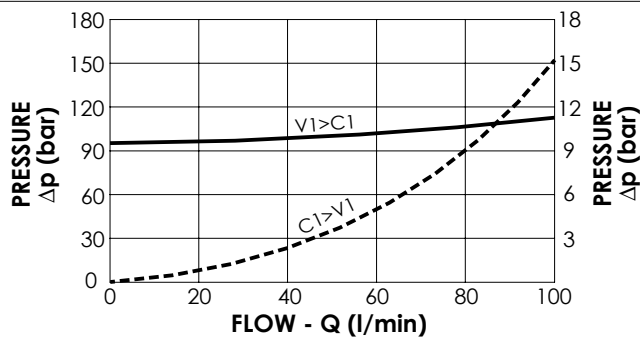

ORDERING CODES

Quick code	Description	Port size	Standard setting (bar, Q=5 l/min)	Adjust. range (bar)	Pressure increase (bar/turn)
CP000092	CPST-100-DHLD-GN-G12-N140	V1,C1: $G\ 1/2"$	100	50 - 140	27
CP000269	CPST-100-DHLD-GN-G12-N220	V1,C1: $G\ 1/2"$	200	100 - 220	39

SEQUENCE VALVE

KPEN-020-DPLD

DIRECT ACTING SOLENOID BY-PASS

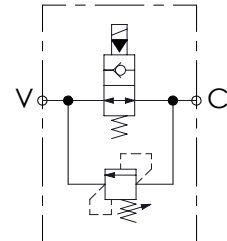
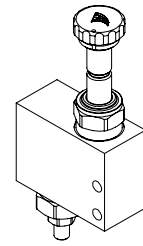
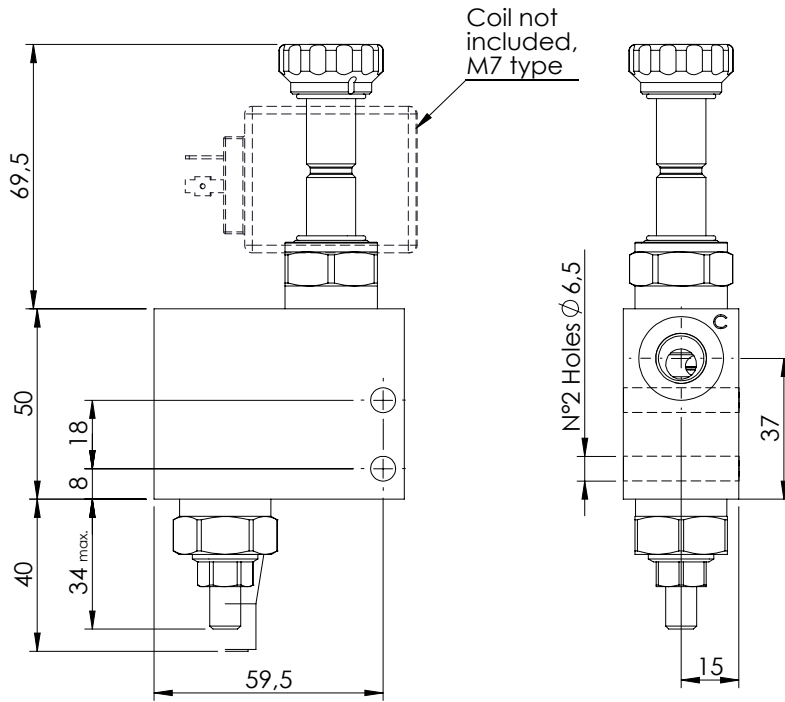
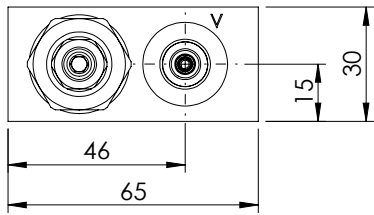

SPECIFICATIONS

Max. operating pressure:	350 bar
Rated flow:	20 l/min
Manifold:	Steel
Weight:	0,83 kg

SEALING CAP

Ordering code:
AT000020

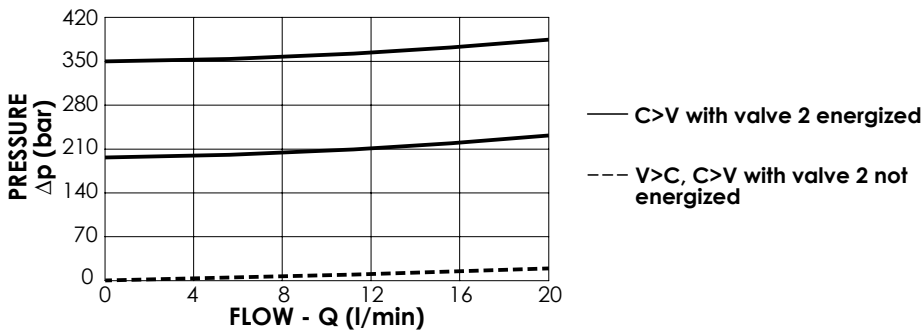
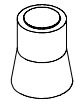

ORDERING CODES

Quick code	Description	Main ports size	Standard setting (bar, Q=5 l/min)	Adjustm. range (bar)	Pressure increase (bar/turn)
KP000109	KPEN-020-DPLD-SN-G14-N350	G 1/4"	350	175-350	177
KP000110	KPEN-020-DPLD-SN-G14-N210	G 1/4"	200	105-210	80



ATLANTIC
Fluid Tech

SECTION 4

Check Valves



1800-OILSOL
1800-645765

<https://oilsolutions.com.au/>

sales@oilsolutions.com.au

SECTION 4

CHECK VALVES



Hydraulic scheme	Valve description	Valve type	Rated flow (l/min)	Max. pressure (bar)	Installation	Main port size or cavity type	Page
	CDVN-010-SSNS	Sphere type	10	350	Cartridge	VP000216	4.01.010
	CDVN-030-PSNR	Poppet type	30	350	Cartridge	VP000015	4.01.020
	CDVN-050-PSNR	Poppet type	50	350	Cartridge	SAE-08-2N	4.01.030
	CDVN-060-PSNR	Poppet type	60	350	Cartridge	VP000006	4.01.040
	CDVN-080-PSNR	Poppet type	80	350	Cartridge	SAE-10-2N	4.01.050
	CDVN-120-PSNR	Poppet type	120	350	Cartridge	SAE-12-2N	4.01.060
	CDVN-010-PAGS	Poppet type, monodirectional	10	350	Cartridge	G 1/8"	4.02.070
	CDVN-020-PAGS	Poppet type, monodirectional	20	350	Cartridge	G 1/4"	4.02.070
	CDVN-050-PAGS	Poppet type, monodirectional	50	350	Cartridge	G 3/8"	4.02.070
	CDVN-080-PAGS	Poppet type, monodirectional	80	350	Cartridge	G 1/2"	4.02.070
	CDVN-120-PAGS	Poppet type, monodirectional	120	350	Cartridge	G 3/4"	4.02.070
	CDVN-010-PANS	Poppet type, monodirectional	10	350	Cartridge	G 1/8"	4.01.080
	CDVN-020-PANS	Poppet type, monodirectional	20	350	Cartridge	G 1/4"	4.01.080
	CDVN-050-PANS	Poppet type, monodirectional	50	350	Cartridge	G 3/8"	4.01.080
	CDVN-080-PANS	Poppet type, monodirectional	80	350	Cartridge	G 1/2"	4.01.080
	CDVN-120-PANS	Poppet type, monodirectional	120	350	Cartridge	G 3/4"	4.01.080
	CDVN-015-SSNS	Sphere type, bidirectional	15	350	Insert	G 1/4"	4.01.090
	CDVN-030-SSNS	Sphere type, bidirectional	30	350	Insert	G 3/8"	4.01.100
	CDVN-050-SSNS	Sphere type, bidirectional	50	350	Insert	G 1/2"	4.01.110
	CDVN-070-PSNS	Sphere type, bidirectional	70	350	Insert	G 1/2"	4.01.120
	CDVN-120-PSNS	Sphere type, bidirectional	120	350	Insert	G 3/4"	4.01.130
	CDVN-030-PSNP-MF	Poppet type	30	350	Sleeve	G1/4"	4.03.140
	CDVN-050-PSNP-MF	Poppet type	50	350	Sleeve	G3/8"	4.03.140
	CDVN-090-PSNP-MF	Poppet type	90	350	Sleeve	G1/2"	4.03.140
	CDVN-150-PSNP-MF	Poppet type	150	350	Sleeve	G3/4"	4.03.140
	CDVN-200-PSNP-MF	Poppet type	200	350	Sleeve	G1"	4.03.140
	CDVN-250-PSNP-MF	Poppet type	250	350	Sleeve	G1"1/4"	4.03.140
	CDVN-030-PSNP-FF	Poppet type	30	350	Sleeve	G1/4"	4.03.150
	CDVN-050-PSNP-FF	Poppet type	50	350	Sleeve	G3/8"	4.03.150
	CDVN-090-PSNP-FF	Poppet type	90	350	Sleeve	G1/2"	4.03.150
	CDVN-150-PSNP-FF	Poppet type	150	350	Sleeve	G3/4"	4.03.150
	CDVN-200-PSNP-FF	Poppet type	200	350	Sleeve	G1"	4.03.150
	CDVN-250-PSNP-FF	Poppet type	250	350	Sleeve	G1"1/4"	4.03.150
	CDVN-010-DSNS	Disk type, bidirectional, not leak proof	10	350	Insert	G1/4"	4.04.160
	CDVN-030-DSNS	Disk type, bidirectional, not leak proof	30	350	Insert	G3/8"	4.04.160
	CDVN-070-DSNS	Disk type, bidirectional, not leak proof	70	350	Insert	G1/2"	4.04.160

CHECK VALVE

CDVN-010-SSNS

SPHERE TYPE

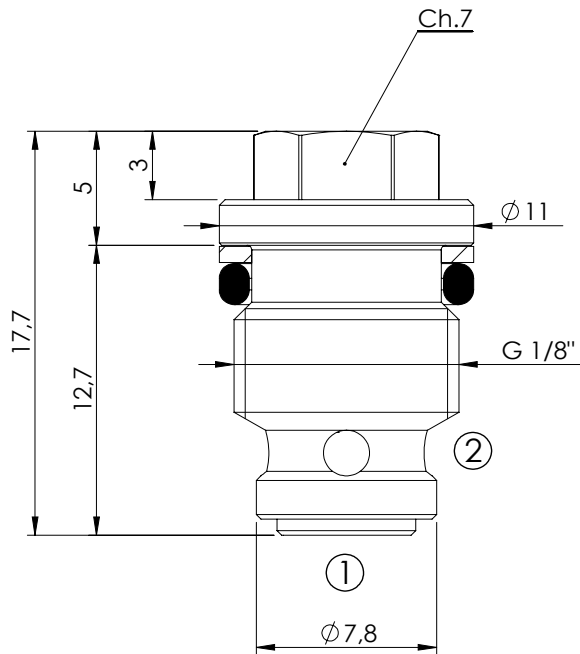
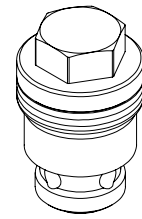

SPECIFICATIONS

Max. operating pressure:	350 bar
Rated flow:	10 l/min
Cavity:	VP000216
Weight:	0,01 kg

NOTES

Installation torque:	6.5 - 7 Nm
Seal kit:	RC700216

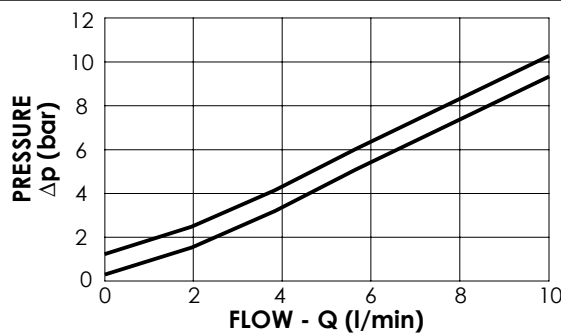

ORDERING CODES

Quick code	Description	Craking pressure (bar)	
CD000094	CDVN-010-SSNS-HN-216-N001	1,2	
CD000134	CDVN-010-SSNS-HN-216-N000	0,3	

CHECK VALVE

CDVN-030-PSNR

POPJET TYPE

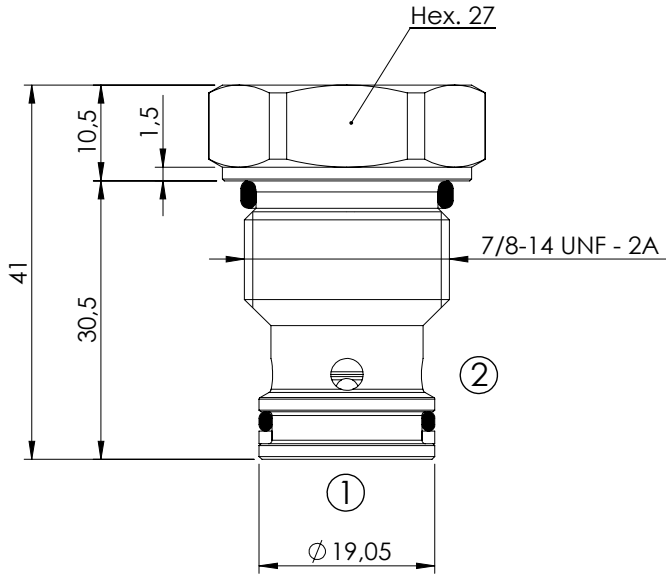
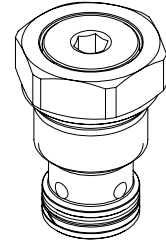

SPECIFICATIONS

Max. operating pressure:	420 bar
Rated flow:	30 l/min
Cavity:	VP000015
Weight:	0,11 kg

NOTES

Installation torque:	76 - 85 Nm
Seal kit:	RC700015

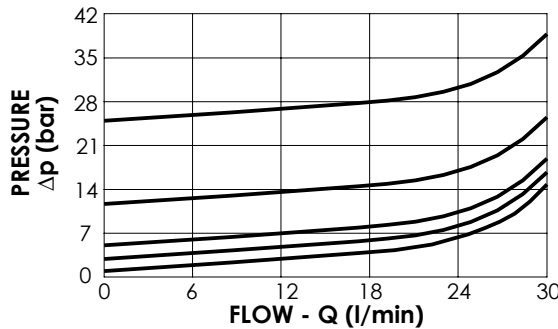

ORDERING CODES

Quick code	Description	Cracking pressure (bar)	Hardened Seat
CD000054	CDVN-030-PSNR-HN-015-N001	1	NO
CD000302	CDVN-030-PANR-HN-015-N001	1	YES
CD000195	CDVN-030-PSNR-HN-015-N003	3	NO
CD000303	CDVN-030-PANR-HN-015-N003	3	YES
CD000055	CDVN-030-PSNR-HN-015-N005	5	NO
CD000304	CDVN-030-PANR-HN-015-N005	5	YES
CD000056	CDVN-030-PSNR-HN-015-N009	9	NO
CD000132	CDVN-030-PANR-HN-015-N009	9	YES
CD000057	CDVN-030-PSNR-HN-015-N025	25	NO
CD000063	CDVN-030-PANR-HN-015-N025	25	YES

CHECK VALVE

CDVN-050-PSNR

POPET TYPE

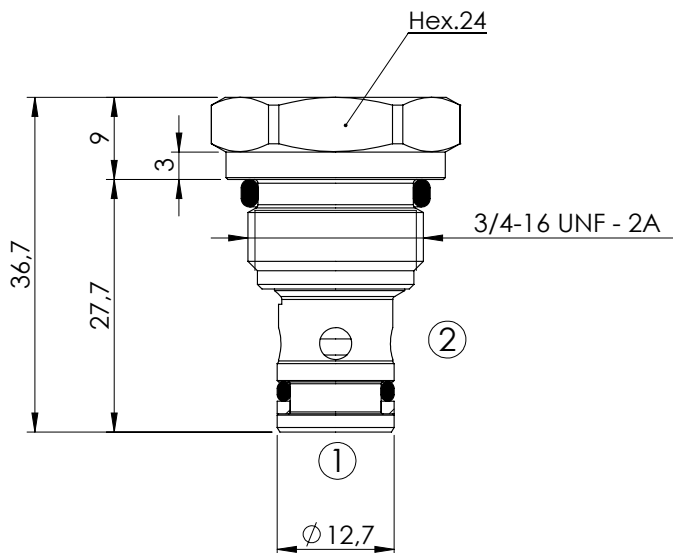
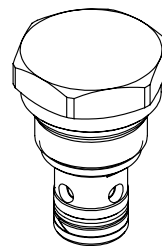

SPECIFICATIONS

Max. operating pressure:	350 bar
Rated flow:	50 l/min
Cavity:	SAE-08-2N
Weight:	0,06 kg

NOTES

Installation torque:	45 - 50 Nm
Seal kit:	RA700081

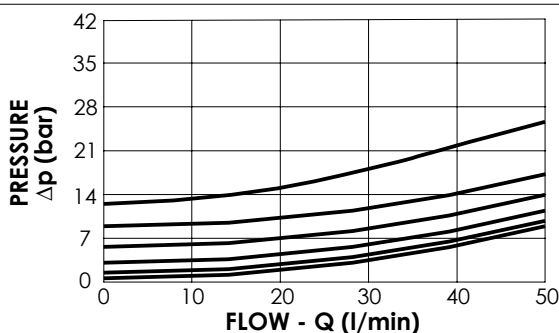

ORDERING CODES

Quick code	Description	Craking pressure (bar)
CD000099	CDVN-050-PSNR-FN-S08-N000	0,35
CD000024	CDVN-050-PSNR-FN-S08-N001	1
CD000039	CDVN-050-PSNR-FN-S08-N003	3
CD000269	CDVN-050-PSNR-FN-S08-N006	6
CD000471	CDVN-050-PSNR-FN-S08-N009	9,5
CD000070	CDVN-050-PSNR-FN-S08-N013	13

CHECK VALVE

CDVN-060-PSNR

POPET TYPE

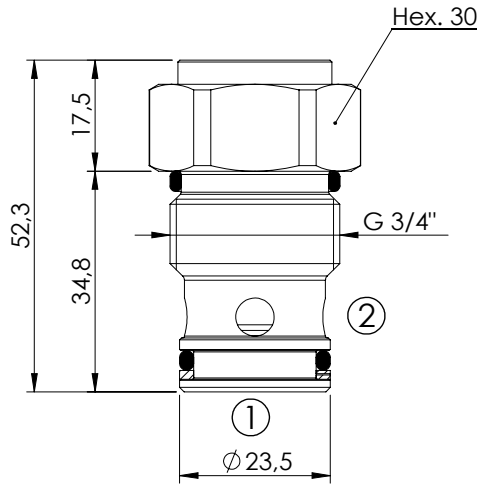
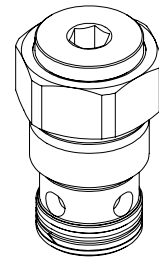

SPECIFICATIONS

Max. operating pressure:	350 bar
Rated flow:	60 l/min
Cavity:	VP000006
Weight:	0,18 kg

NOTES

Installation torque:	100 - 130 Nm
Seal kit:	RC700006

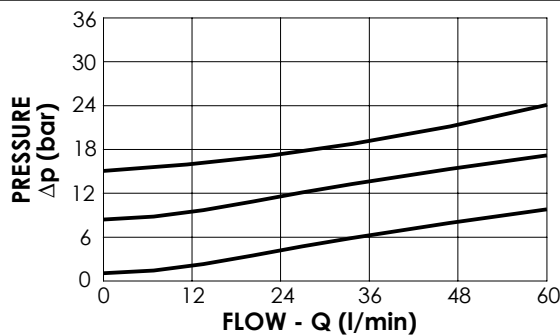

ORDERING CODES

Quick code	Description	Cracking pressure (bar)	
CD000019	CDVN-060-PSNR-FN-006-N001	1	
CD000020	CDVN-060-PSNR-FN-006-N009	9	
CD000075	CDVN-060-PSNR-FN-006-N015	15	

CHECK VALVE

CDVN-080-PSNR

POPPET TYPE

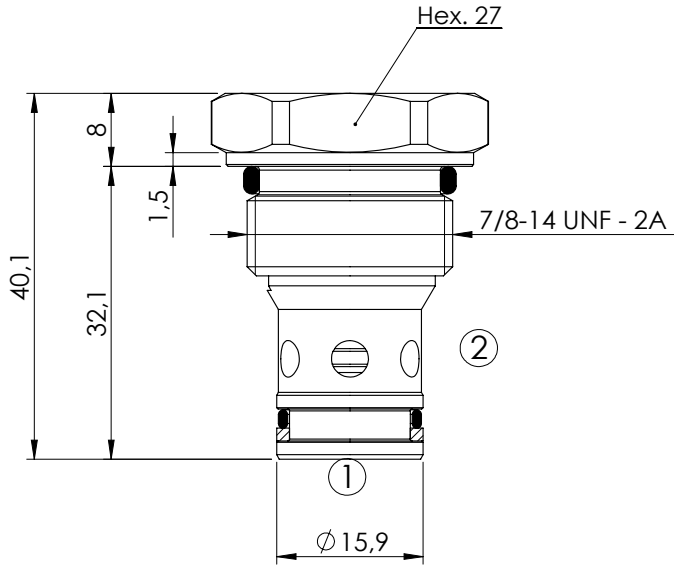
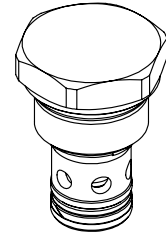

SPECIFICATIONS

Max. operating pressure:	350 bar
Rated flow:	80 l/min
Cavity:	SAE-10-2N
Weight:	0,09 kg

NOTES

Installation torque:	55 - 62 Nm
Seal kit:	RA700082

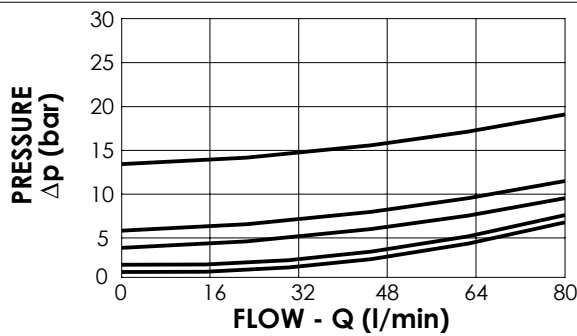

ORDERING CODES

Quick code	Description	Cracking pressure (bar)	
CD000100	CDVN-080-PSNR-FN-S10-N000	0,35	
CD000023	CDVN-080-PSNR-FN-S10-N001	1	
CD000169	CDVN-080-PSNR-FN-S10-N003	3,7	
CD000101	CDVN-080-PSNR-FN-S10-N005	5,5	
CD000082	CDVN-080-PSNR-FN-S10-N013	13	

CHECK VALVE

CDVN-120-PSNR

POPPET TYPE

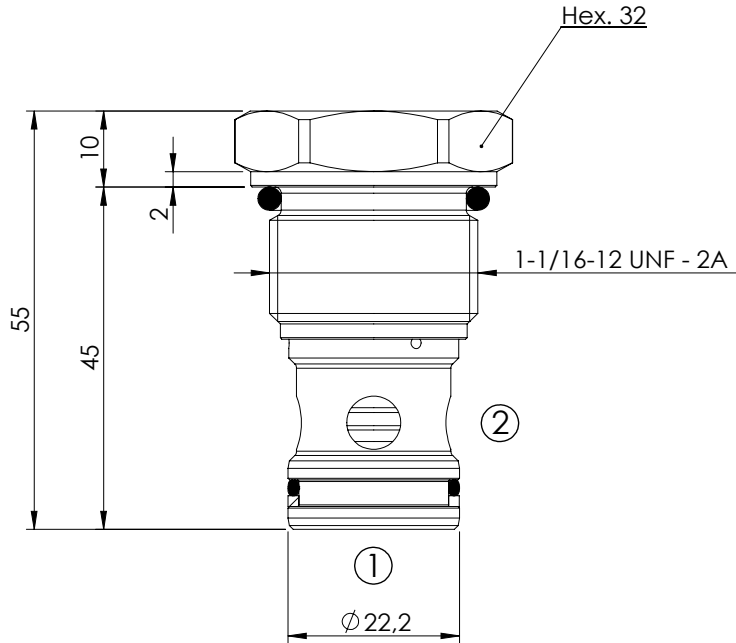
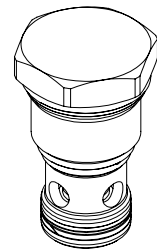

SPECIFICATIONS

Max. operating pressure:	350 bar
Rated flow:	120 l/min
Cavity:	SAE-12-2N
Weight:	0,18 kg

NOTES

Installation torque:	110 - 130 Nm
Seal kit:	RA700083

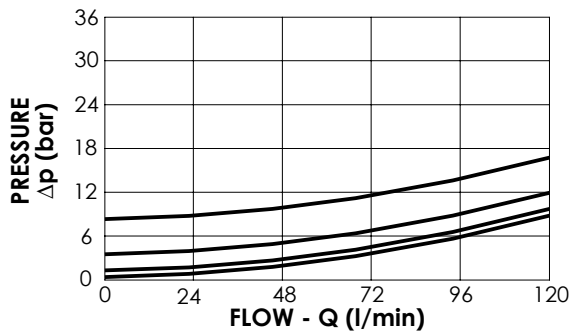

ORDERING CODES

Quick code	Description	Craking pressure (bar)	
CD000444	CDVN-120-PSNR-FN-S12-N000	0,3	
CD000046	CDVN-120-PSNR-FN-S12-N001	1	
CD000310	CDVN-120-PSNR-FN-S12-N004	4	
CD000445	CDVN-120-PSNR-FN-S12-N008	8	

CHECK VALVE

CDVN-XXX-PAGS

MONODIRECTIONAL
POPET TYPE

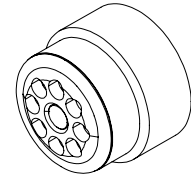
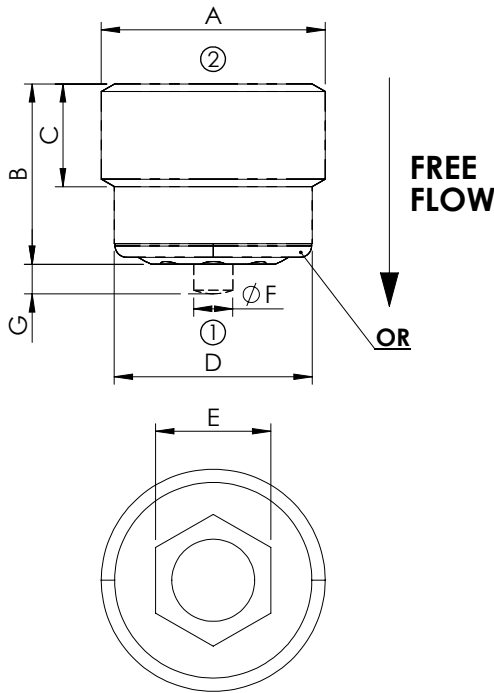

SPECIFICATIONS

Max. operating pressure: 500 bar

Quick code	A	B	C	D	E	F	G	OR
CD000179	G 1/8"	7,9	4,5	8,6	Hex. 5	1,7	1,3	6,00 x 1 N70
CD000180	G 1/4"	10,3	5,5	11,6	Hex. 7	2,0	1,3	9,00 x 1 N70
CD000181	G 3/8"	11,7	7,0	15	Hex. 6	2,7	2,0	11,00 x 1,5 N70
CD000182	G 1/2"	13,2	8,0	18,5	Hex.8	3,2	2,5	14,00 x 1,5 N70
CD000183	G 3/4"	17,1	10,5	24,0	Hex.12	5,5	3,8	18,77 x 1,78 N70

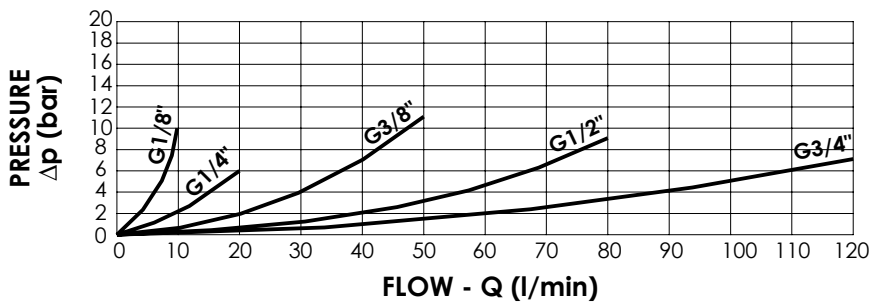

NOTES

Hardened seat and piston

ORDERING CODES

Quick code	Description	Cracking pressure (bar)	Rated flow (l/min)	Cavity	Installation torque (Nm)
CD000179	CDVN-010-PAGS-307-N001	0.1	10	VP000307 (G1/8")	8
CD000180	CDVN-020-PAGS-309-N001	0.1	20	VP000309 (G1/4")	15
CD000181	CDVN-050-PAGS-310-N001	0.1	50	VP000310 (G3/8")	20
CD000182	CDVN-080-PAGS-311-N001	0.2	80	VP000311 (G1/2")	40
CD000183	CDVN-120-PAGS-312-N001	0.1	120	VP000312 (G3/4")	80

CHECK VALVE

CDVN-XXX-PANS

MONODIRECTIONAL
POPPET TYPE

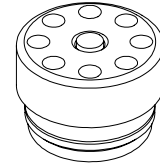
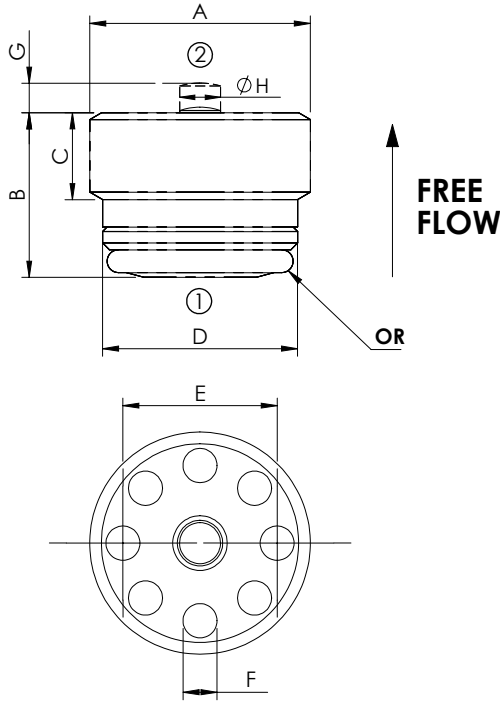

SPECIFICATIONS

Max. operating pressure: 500 bar

Quick code	A	B	C	D	E	F	G	H	OR
CD000173	G 1/8"	7,2	3,8	8,6	6,8	1,5	1,3	1,8	6.00 x 1 N70
CD000174	G 1/4"	9,0	4,5	11,5	8,8	2,2	1,5	2,4	9.00 x 1 N70
CD000175	G 3/8"	11,2	6,5	15,0	11,0	3,0	2,5	3,2	11.00 x 1.5 N70
CD000176	G 1/2"	13,5	8,0	18,5	14,2	3,8	3,0	4,0	14.00 x 1.5 N70
CD000178	G 3/4"	17,5	10,0	24,0	18,5	4,6	3,5	5,5	18.77 x 1.78 N70

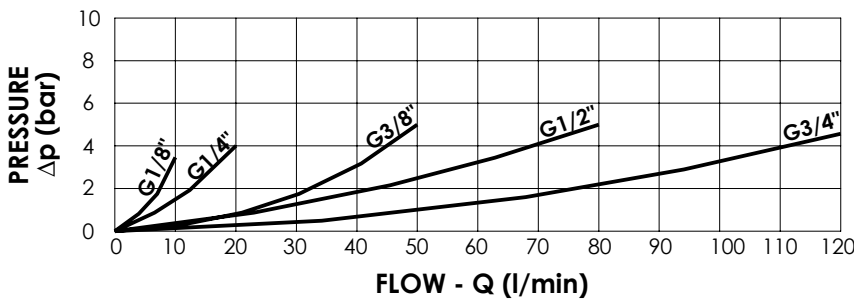

NOTES

Hardened seat and piston

ORDERING CODES

Quick code	Description	Cracking pressure (bar)	Rated flow (l/min)	Cavity	Installation torque (Nm)	Installation tool
CD000173	CDVN-010-PANS-307-N001	0,1	10	VP000307 (G1/8")	8	UM000390
CD000174	CDVN-020-PANS-309-N001	0,2	20	VP000309 (G1/4")	15	UM000391
CD000175	CDVN-050-PANS-310-N001	0,2	50	VP000310 (G3/8")	20	UM000392
CD000176	CDVN-080-PANS-311-N001	0,2	80	VP000311 (G1/2")	40	UM000393
CD000178	CDVN-120-PANS-312-N001	0,1	120	VP000312 (G3/4")	80	UM000394

CHECK VALVE

CDVN-015-SSNS

MONO-DIRECTIONAL
SPHERE TYPE

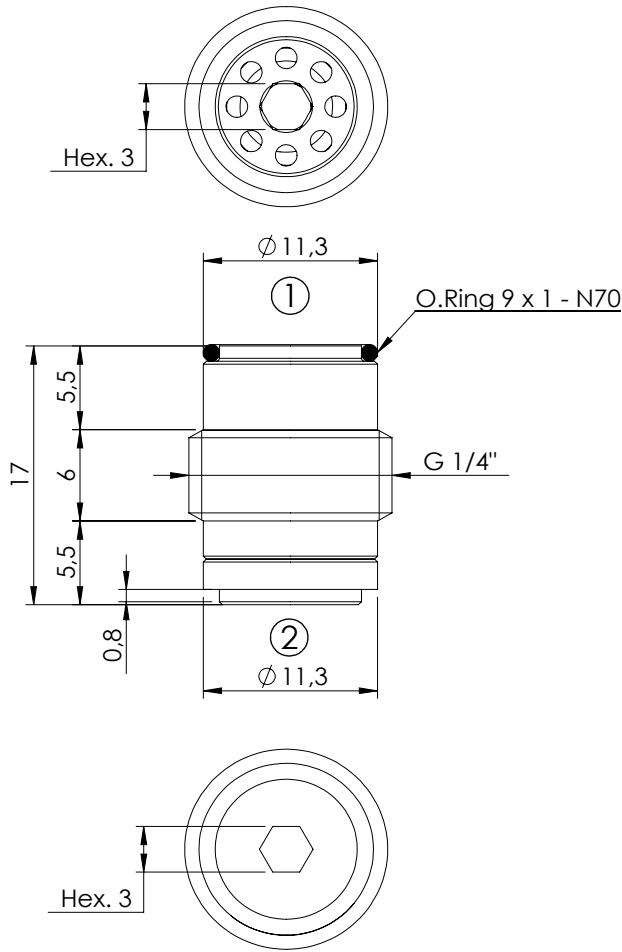
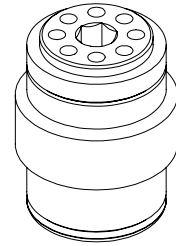

SPECIFICATIONS

Max. operating pressure:	350 bar
Rated flow:	15 l/min
Cavity:	VP000098
Weight:	0,01 kg

NOTES

Installation torque:	6 Nm
----------------------	------

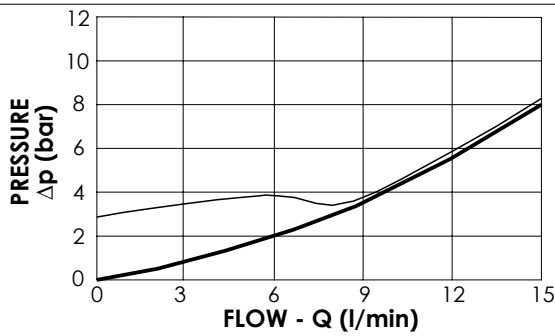

ORDERING CODES

Quick code	Description	Cracking pressure (bar)	
CD000026	CDVN-015-SSNS-FN-098-N003	3	
CD000043	CDVN-015-SSNS-FN-098-N000	0	

CHECK VALVE

CDVN-030-SSNS

MONO DIRECTIONAL
SPHERE TYPE

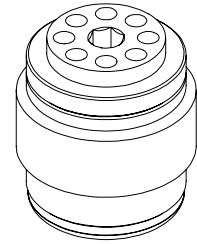
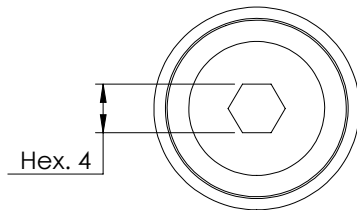
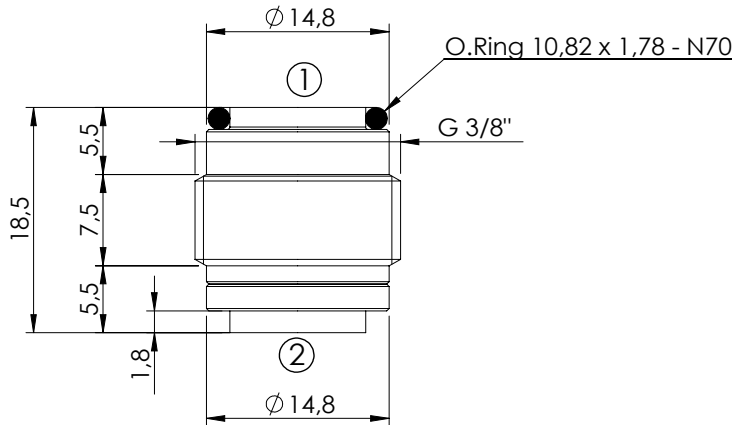
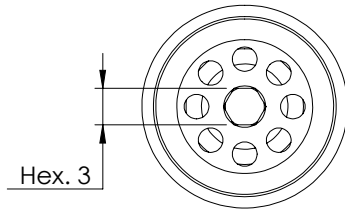

SPECIFICATIONS

Max. operating pressure:	350 bar
Rated flow:	30 l/min
Cavity:	VP000310
Weight:	0,02 kg

NOTES

Installation torque:	8 Nm
----------------------	------

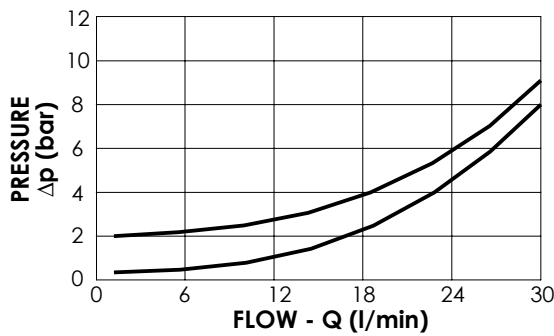

ORDERING CODES

Quick code	Description	Cracking pressure (bar)	
CD000029	CDVN-030-SSNS-FN-310-N002	2	
CD000058	CDVN-030-SSNS-FN-310-N000	0	

CHECK VALVE

CDVN-050-SSNS

**BIDIRECTIONAL
SPHERE TYPE**

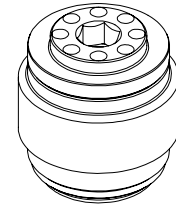
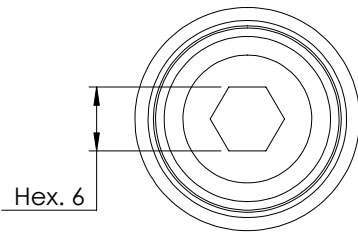
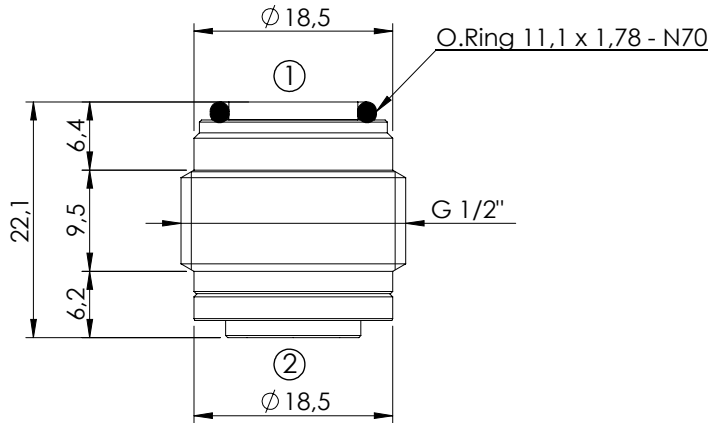
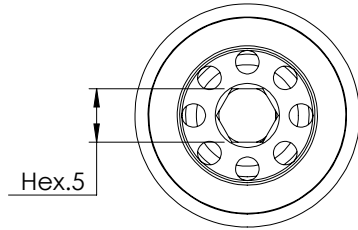

SPECIFICATIONS

Max. operating pressure:	350 bar
Rated flow:	50 l/min
Cavity:	VP000158
Weight:	0,04 kg

NOTES

Installation torque: 25 Nm
 Bidirectional installations.
 Fit O-Ring to side first inserted in cavity.

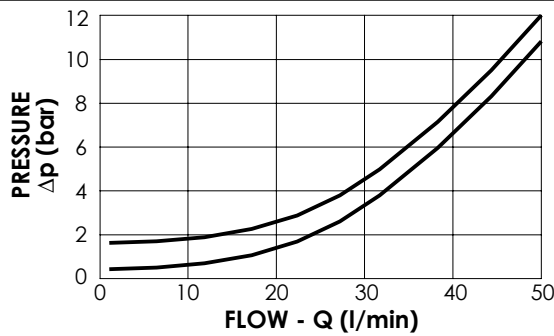

ORDERING CODES

Quick code	Description	Cracking pressure (bar)	
CD000098	CDVN-050-SSNS-FN-158-N002	1,5	
CD000059	CDVN-050-SSNS-FN-158-N000	0	

CHECK VALVE

CDVN-070-PSNS

BIDIRECTIONAL
POPPET TYPE

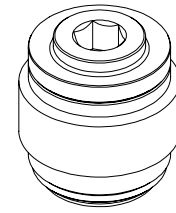
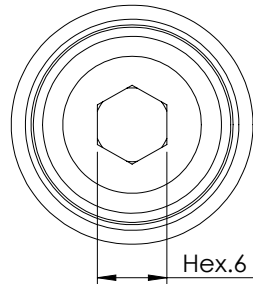
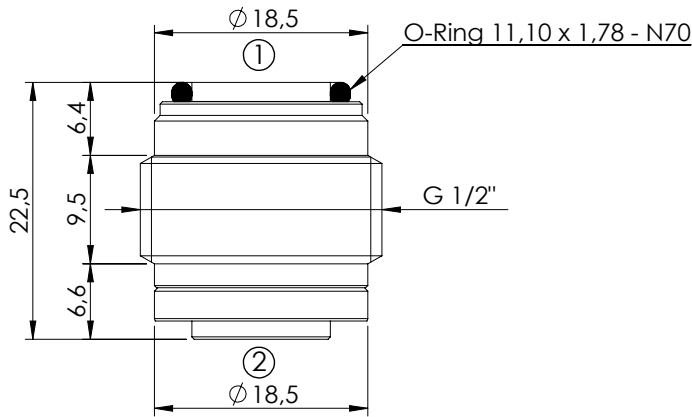
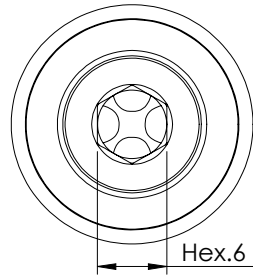

SPECIFICATIONS

Max. operating pressure:	350 bar
Rated flow:	70 l/min
Cavity:	VP000158
Weight:	0,04 kg

NOTES

Installation torque: 25-30 Nm

The valve can be assembled in both ways, OR to be placed only on the side first introduced in the cavity

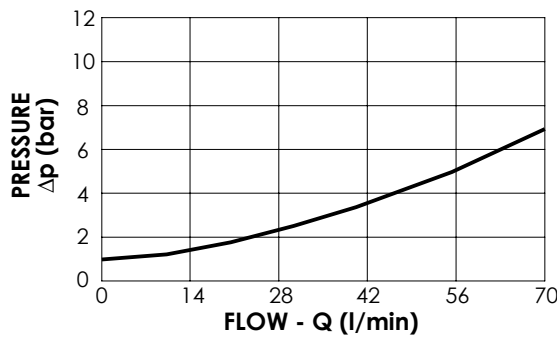

ORDERING CODES

Quick code	Description	Cracking pressure (bar)	
CD000107	CDVN-070-PSNS-FN-158-N001	1	

CHECK VALVE

CDVN-120-PSNS

**BIDIRECTIONAL
POPPET TYPE**

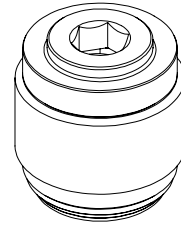
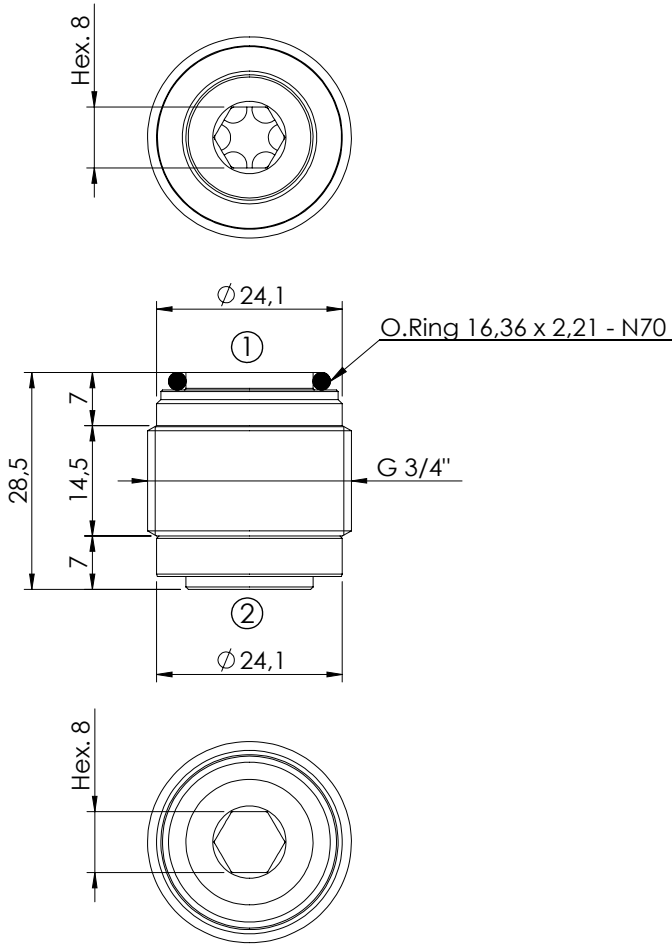

SPECIFICATIONS

Max. operating pressure:	350 bar
Rated flow:	120 l/min
Cavity:	VP000202
Weight:	0,08 kg

NOTES

Installation torque: 60 - 75 Nm

The valve can be assembled in both ways, OR to be placed only on the side first introduced in the cavity

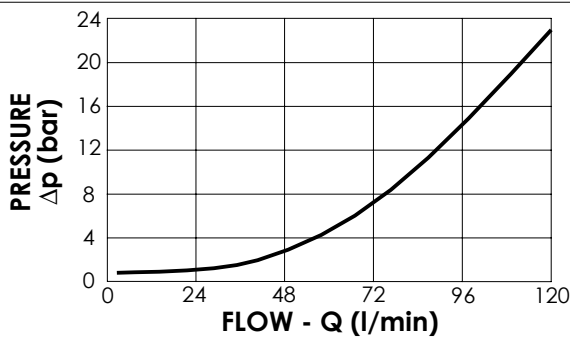

ORDERING CODES

Quick code	Description	Cracking pressure (bar)	
CD000106	CDVN-120-PSNS-FN-202-N001	1	

CHECK VALVE

CDVN-XXX-PSNP

SLEEVE
POPPET TYPE

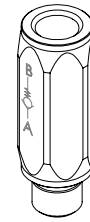
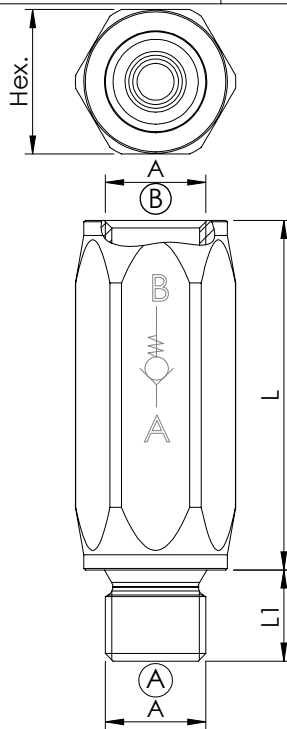

SPECIFICATIONS

Max. operating pressure:	350 bar
Rated flow:	30 - 350 l/min
Body:	Zinc plated steel

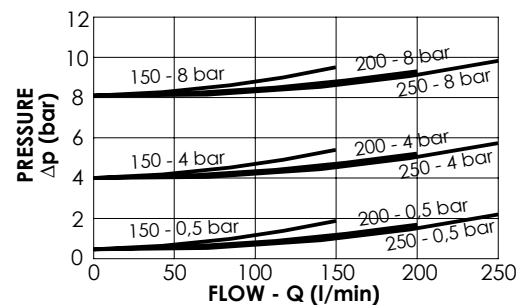
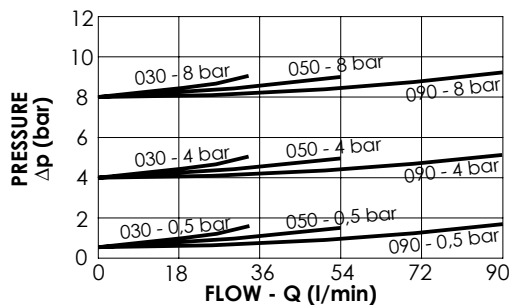

ORDERING CODES

Quick code	Description	Rated flow (l/min)	Cracking pressure (bar)	Dimension			
				A	L	L1	HEX
CD000425	CDVN-030-PSNP-MF-G14-N008	30	8	G 1/4"	46	12	19
CD000424	CDVN-030-PSNP-MF-G14-N004	30	4	G 1/4"	46	12	19
CD000423	CDVN-030-PSNP-MF-G14-N001	30	0,5	G 1/4"	46	12	19
CD000428	CDVN-050-PSNP-MF-G38-N008	50	8	G 3/8"	50	12	24
CD000427	CDVN-050-PSNP-MF-G38-N004	50	4	G 3/8"	50	12	24
CD000426	CDVN-050-PSNP-MF-G38-N001	50	0,5	G 3/8"	50	12	24
CD000136	CDVN-090-PSNP-MF-G12-N008	90	8	G 1/2"	57	14	30
CD000291	CDVN-090-PSNP-MF-G12-N004	90	4	G 1/2"	57	14	30
CD000142	CDVN-090-PSNP-MF-G12-N001	90	0,5	G 1/2"	57	14	30
CD000139	CDVN-150-PSNP-MF-G34-N008	150	8	G 3/4"	60	16	36
CD000292	CDVN-150-PSNP-MF-G34-N004	150	4	G 3/4"	60	16	36
CD000143	CDVN-150-PSNP-MF-G34-N001	150	0,5	G 3/4"	60	16	36
CD000140	CDVN-200-PSNP-MF-G10-N008	200	8	G 1"	88	18	45
CD000293	CDVN-200-PSNP-MF-G10-N004	200	4	G 1"	88	18	45
CD000144	CDVN-200-PSNP-MF-G10-N001	200	0,5	G 1"	88	18	45
CD000141	CDVN-250-PSNP-MF-G11-N008	250	8	G 1" 1/4	102	20	55
CD000294	CDVN-250-PSNP-MF-G11-N004	250	4	G 1" 1/4	102	20	55
CD000145	CDVN-250-PSNP-MF-G11-N001	250	0,5	G 1" 1/4	102	20	55

CHECK VALVE

CDVN-XXX-PSNP

SLEEVE
POPPET TYPE

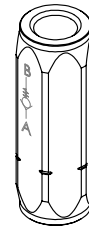
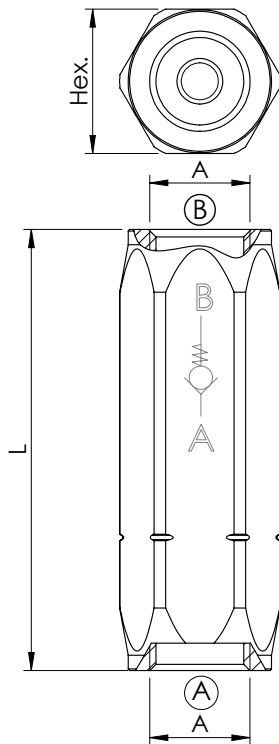

SPECIFICATIONS

Max. operating pressure:	350 bar
Rated flow:	30 - 250 l/min
Body:	Zinc plated steel

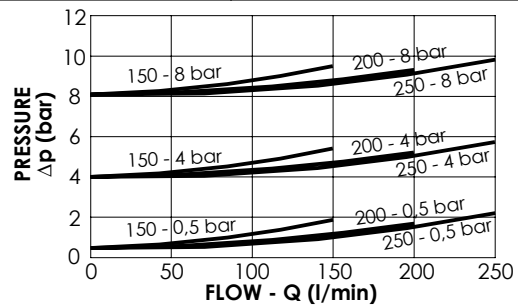
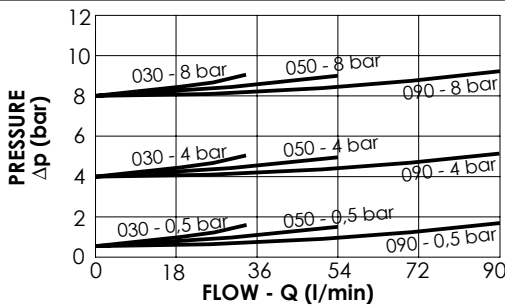

ORDERING CODES

Quick code	Description	Rated flow (l/min)	Cracking pressure (bar)	Dimension		
				A	L	HEX
CD000324	CDVN-030-PSNP-FF-G14-N008	30	8	G 1/4"	58	19
CD000312	CDVN-030-PSNP-FF-G14-N004	30	4	G 1/4"	58	19
CD000317	CDVN-030-PSNP-FF-G14-N001	30	0,5	G 1/4"	58	19
CD000323	CDVN-050-PSNP-FF-G38-N008	50	8	G 3/8"	62	24
CD000318	CDVN-050-PSNP-FF-G38-N004	50	4	G 3/8"	62	24
CD000212	CDVN-050-PSNP-FF-G38-N001	50	0,5	G 3/8"	62	24
CD000277	CDVN-090-PSNP-FF-G12-N008	90	8	G 1/2"	71	30
CD000287	CDVN-090-PSNP-FF-G12-N004	90	4	G 1/2"	71	30
CD000281	CDVN-090-PSNP-FF-G12-N001	90	0,5	G 1/2"	71	30
CD000278	CDVN-150-PSNP-FF-G34-N008	150	8	G 3/4"	83	36
CD000421	CDVN-150-PSNP-FF-G34-N006	150	6	G 3/4"	83	36
CD000288	CDVN-150-PSNP-FF-G34-N004	150	4	G 3/4"	83	36
CD000282	CDVN-150-PSNP-FF-G34-N001	150	0,5	G 3/4"	83	36
CD000279	CDVN-200-PSNP-FF-G10-N008	200	8	G 1"	106	45
CD000289	CDVN-200-PSNP-FF-G10-N004	200	4	G 1"	106	45
CD000283	CDVN-200-PSNP-FF-G10-N001	200	0,5	G 1"	106	45
CD000280	CDVN-250-PSNP-FF-G11-N008	250	8	G 1" 1/4	127	55
CD000290	CDVN-250-PSNP-FF-G11-N004	250	4	G 1" 1/4	127	55
CD000284	CDVN-250-PSNP-FF-G11-N001	250	0,5	G 1" 1/4	127	55

CHECK VALVE

CDVN-010-DSNS

INSERT TYPE
DOUBLE MOUNTING

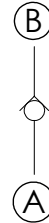
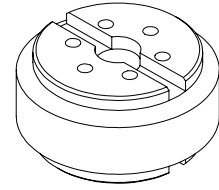
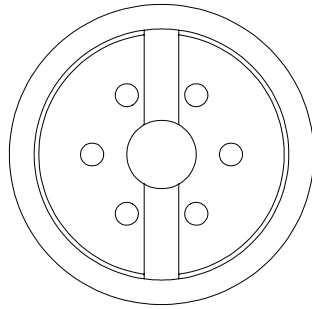
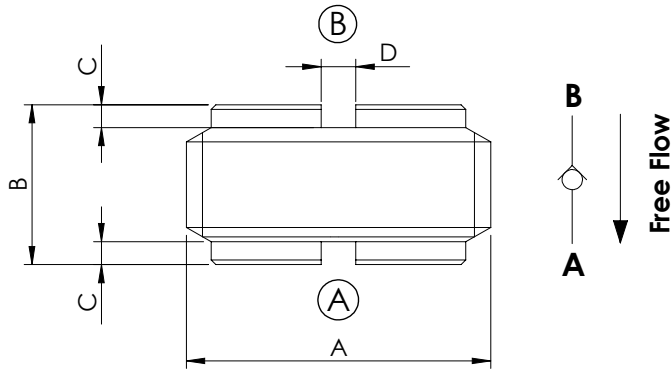

SPECIFICATIONS

Max. operating pressure:	350 bar
Rated flow:	See table
Cavity:	See table
Weight:	0,1 kg

NOTES

- Disk type
- Not leak proof
- Without spring

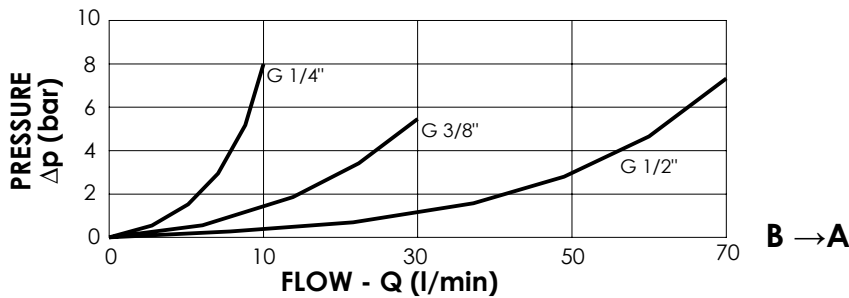

CODE	RATED FLOW
G 1/4"	10 l/min
G 3/8"	30 l/min
G 1/2"	70 l/min

ORDERING CODES

Quick code	Description	Install. torque (Nm)	Cracking pressure (bar)	Dimension			
				A	B	C	D
CD000150	CDVN-010-DSNS-00-G14-N350	5	0	G 1/4"	7	1	1,5
CD000148	CDVN-030-DSNS-00-G38-N350	10	0	G 3/8"	7,5	1	1,5
CD000151	CDVN-070-DSNS-00-G12-N350	10	0	G 1/2"	11	1,5	1,5



ATLANTIC
Fluid Tech

SECTION 5

Pilot
Operated
Check Valves



1800-OILSOL
1800-645765

<https://oilsolutions.com.au/>

sales@oilsolutions.com.au

SECTION 5

PILOT OPERATED CHECK VALVES



Hydraulic scheme	Valve description	Valve type	Rated flow (l/min)	Max. pressure (bar)	Installation	Main port size or cavity type	Page
	CDPN-030-PSGR	Poppet type	30	350	Cartridge	SAE-08-3C	5.01.010
	CDPN-060-PSGR	Poppet type	60	350	Cartridge	SAE-10-3C	5.01.020
	CDPN-060-PSGR	Poppet type	60	350	Cartridge	VP000161 (F-11A)	5.01.030
	CDPN-120-PSGR	Poppet type	120	350	Cartridge	VP000165 (F-2A)	5.01.040
	CDPN-030-PANR	Poppet type	30	350	Cartridge	VP000314	5.02.050
	CDPN-030-PSNE	Poppet type, separate pilot piston	30	350	Cartridge	VP000028	5.02.060
	CDPN-050-PSNN	Poppet type, separate pilot piston	50	350	Cartridge	VP000193	5.02.070
	CDPN-060-PSNN	Poppet type, separate pilot piston	60	350	Cartridge	VP000038	5.02.080
	MCSN-020-SLAC	Single acting, poppet type	20	350	In line	G 1/4"	5.03.090
	MCSN-030-TLNS	Single acting, poppet type	30	350	In line	G 3/8"	5.03.100
	MCSN-030-TANS	Single acting, poppet type	30	350	Flanged	G 3/8"	5.03.110
	MCSN-060-TLNS	Single acting, poppet type	60	350	In line	G 1/2"	5.03.120
	MCSN-060-TANS	Single acting, poppet type	60	350	Flanged	G 1/2"	5.03.130
	MCSN-100-TLNS	Single acting, poppet type	100	350	In line	G 3/4"	5.03.140
	MCSN-020-TLLC	Single acting, manual shut off, left version	20	210	In line	G 3/8"	5.04.150
	MCSN-020-TLRC	Single acting, manual shut off, right version	20	210	In line	G 3/8"	5.04.160
	MCDN-020-SLAS	Double acting, poppet type	20	350	In line	G 1/4"	5.05.170
	MCDN-020-SLAS	Double acting, poppet type, steel body	20	350	In line	G 3/8"	5.05.180
	MCDN-020-SLGS	Double acting, poppet type, with banjo	20	350	In line	G 3/8"	5.05.190
	MCDN-030-TLNS	Double acting, poppet type	30	350	In line	G 3/8"	5.05.200
	MCDN-030-ZBNS	Double acting, poppet type	30	350	Flanged	G 3/8"	5.05.210
	MCDN-030-TBNS	Double acting, poppet type	30	350	Flanged	G 1/4"	5.05.220
	MCDN-030-SBNS	Double acting, poppet type, steel body	30	350	Flanged	G 3/8"	5.05.230
	MCDN-060-TLNS	Double acting, poppet type	60	350	In line	G 1/2"	5.05.240
	MCDN-060-TBNS	Double acting, poppet type	60	350	Flanged	G 1/2"	5.05.250
	MCDN-100-LLNR	Double acting, poppet type	100	350	In line	G 3/4"	5.05.260

PILOTED CHECK VALVE

CDPN-030-PSGR

INTEGRAL PILOT
PISTON

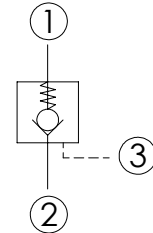
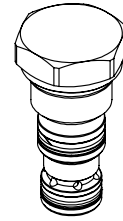
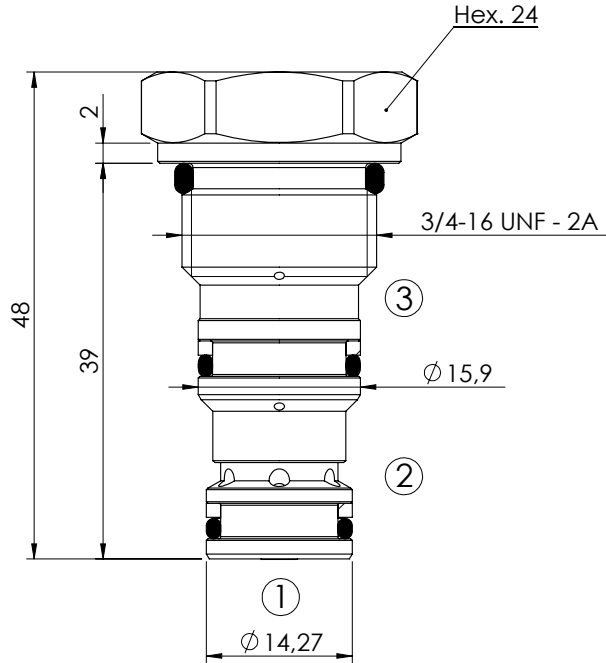

SPECIFICATIONS

Max. operating pressure:	350 bar
Rated flow:	30 l/min
Cavity:	SAE-08-3C
Weight:	0,09 kg
Pilot ratio:	3:1
NOTES	
Installation torque:	40 - 45 Nm
Seal kit:	RA700086

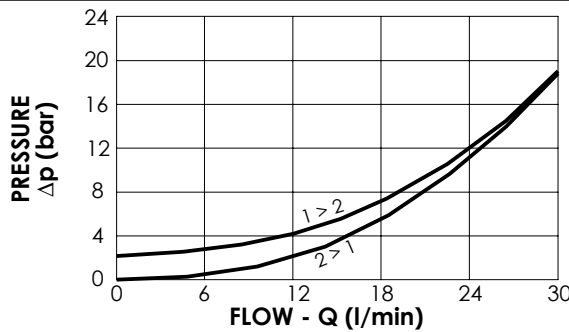

ORDERING CODES

Quick code	Description	Cracking pressure (bar)	O-Ring on pilot piston	
CD000027	CDPN-030-PSGR-03-S08-N002	2	YES	
CD000061	CDPN-030-PSGM-03-S08-N002	2	NO	

PILOTED CHECK VALVE

CDPN-060-PSGR

INTEGRAL PILOT
PISTON

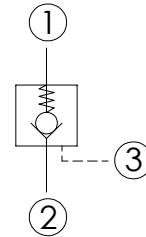
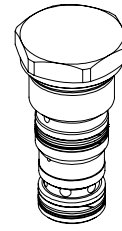
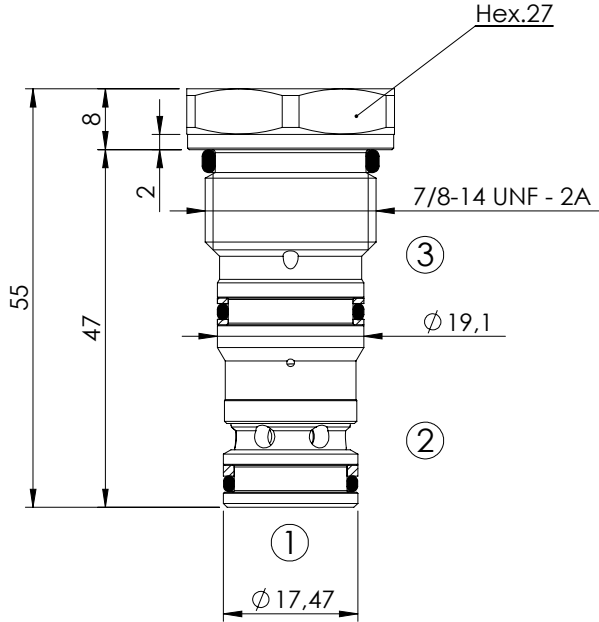

SPECIFICATIONS

Max. operating pressure:	350 bar
Rated flow:	60 l/min
Cavity:	SAE-10-3C
Weight:	0,12 kg
Pilot ratio:	3,2 : 1
NOTES	
Installation torque:	55 - 62 Nm
Seal kit:	RB700087

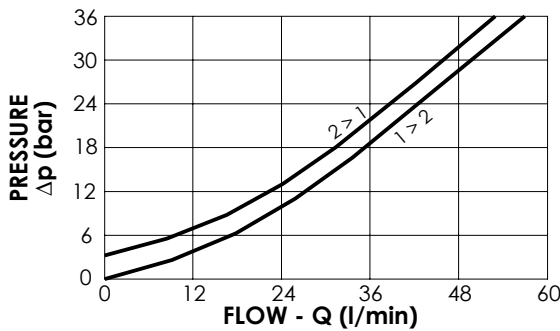

ORDERING CODES

Quick code	Description	Cracking pressure (bar)	O-Ring on pilot piston	
CD000109	CDPN-060-PSGR-03-S10-N002	2	YES	
CD000113	CDPN-060-PSGM-03-S10-N002	2	NO	
CD000170	CDPN-060-PSGR-03-S10-N005	5	YES	
CD000171	CDPN-060-PSGM-03-S10-N005	5	NO	

PILOTED CHECK VALVE

CDPN-060-PSGR

INTEGRAL PILOT
PISTON

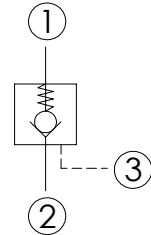
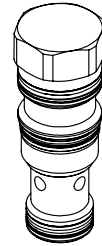
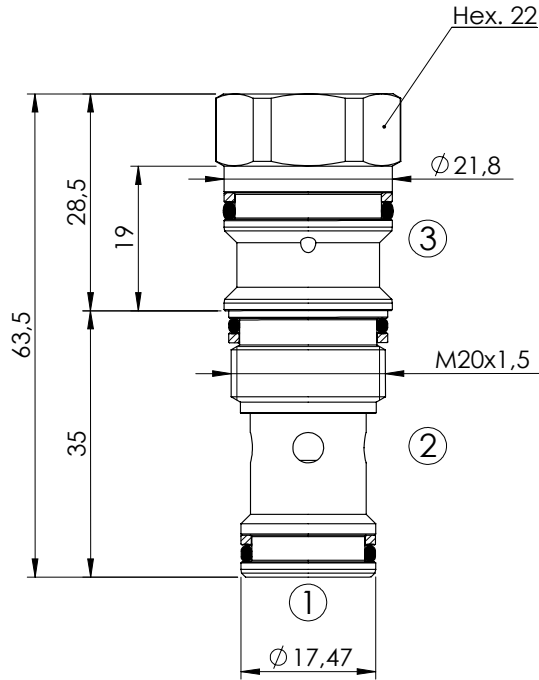

SPECIFICATIONS

Max. operating pressure:	350 bar
Rated flow:	60 l/min
Cavity:	VP000161 (SUN T-11A)
Weight:	0,12 kg
Pilot ratio:	3,2 : 1

NOTES

Installation torque:	40 - 50 Nm
Seal kit:	RC700161

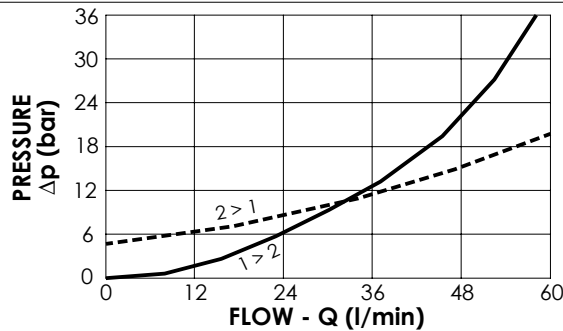

ORDERING CODES

Quick code	Description	Cracking pressure (bar)	O-Ring on pilot piston	
CD000226	CDPN-060-PSGR-03-161-N002	2	YES	
CD000227	CDPN-060-PSGM-03-161-N002	2	NO	
CD000224	CDPN-060-PSGR-03-161-N005	5	YES	
CD000225	CDPN-060-PSGM-03-161-N005	5	NO	
CD000229	CDPN-060-PSGR-03-161-N007	7	YES	

PILOTED CHECK VALVE

CDPN-120-PSGR

INTEGRAL PILOT
PISTON

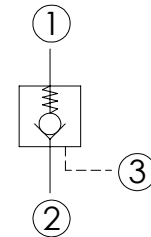
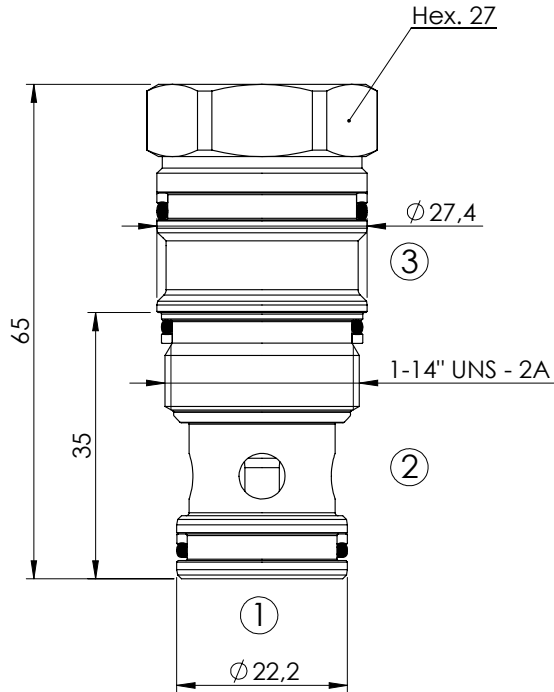
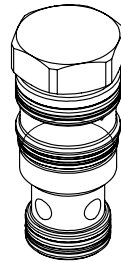

SPECIFICATIONS

Max. operating pressure:	350 bar
Rated flow:	120 l/min
Cavity:	VP000165 (SUN T-2A)
Weight:	0,2 kg
Pilot ratio:	3,5 : 1

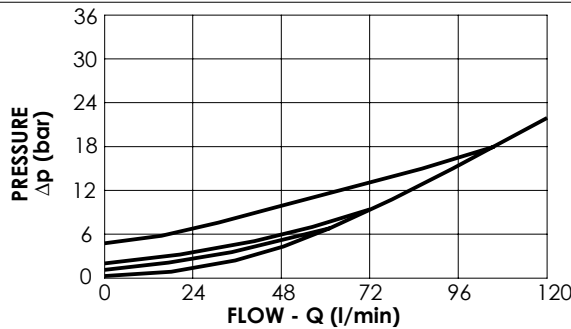

NOTES

Installation torque:	60 - 65 Nm
Seal kit:	RC700165

ORDERING CODES

Quick code	Description	Craking pressure (bar)	O-Ring on pilot piston
CD000546	CDPN-120-PSGR-03-165-N000	0,3	YES
CD000504	CDPN-120-PSGR-03-165-N002	2	YES
CD000549	CDPN-120-PSGM-03-165-N002	2	NO
CD000536	CDPN-120-PSGM-03-165-N003	3	NO
CD000547	CDPN-120-PSGR-03-165-N005	5	YES

PILOTED CHECK VALVE

CDPN-030-PANR

INTEGRAL PILOT
PISTON

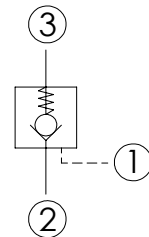
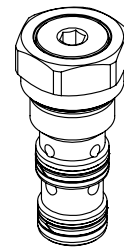
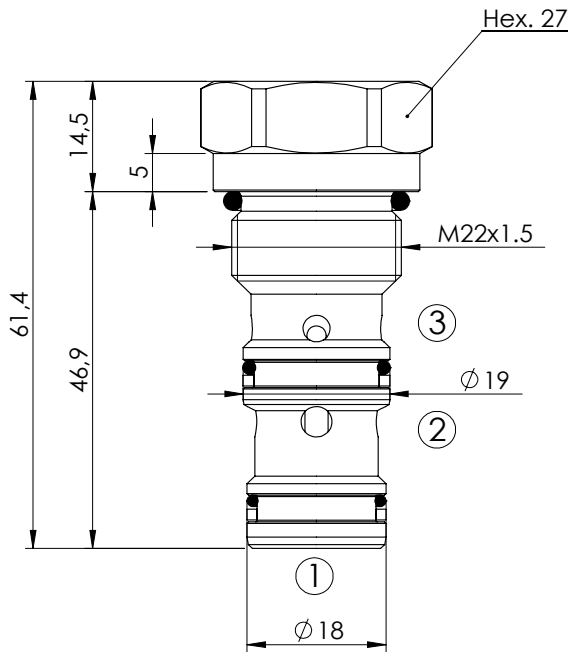

SPECIFICATIONS

Max. operating pressure:	350 bar
Rated flow:	30 l/min
Cavity:	VP000314
Weight:	0,1 kg
Pilot ratio:	4 : 1

NOTES

Installation torque:	55 - 62 Nm
Seal kit:	RC700314

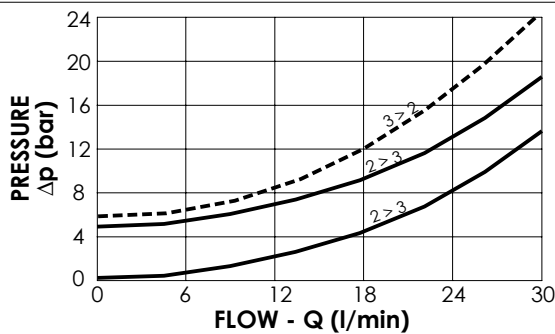

ORDERING CODES

Quick code	Description	Cracking pressure (bar)	O-Ring on pilot piston
CD000186	CDPN-030-PANR-04-314-N005	5	YES
CD000235	CDPN-030-PANM-04-314-N001	1	NO

PILOT OPERATED CHECK VALVE

CDPN-030-PSNE

SEPARATE PILOT
PISTON

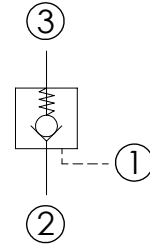
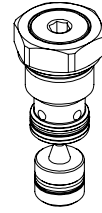
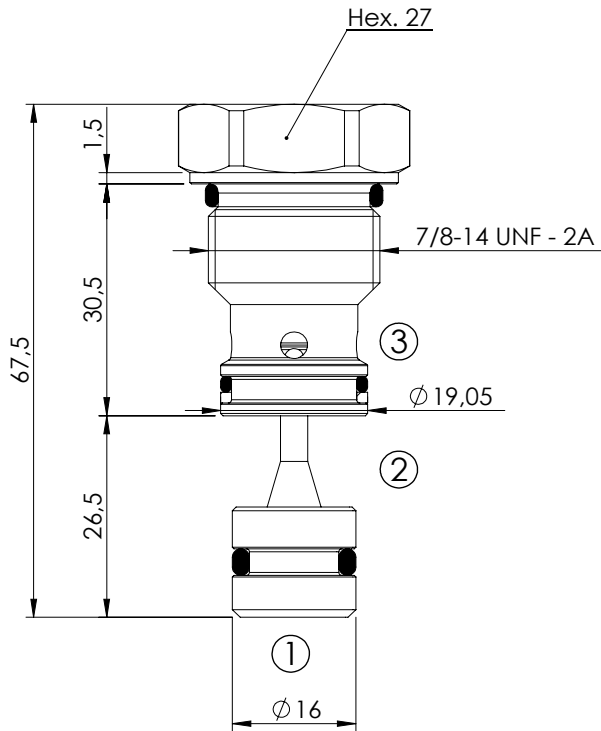

SPECIFICATIONS

Max. operating pressure:	350 bar
Rated flow:	30 l/min
Cavity:	VP000028
Weight:	0,13 kg
Pilot ratio:	7:1

NOTES

Installation torque: 80 - 90 Nm

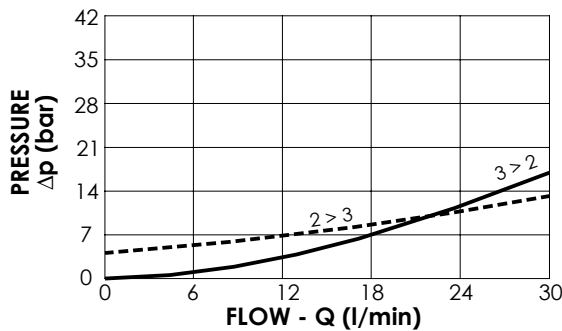

ORDERING CODES

Quick code	Description	Cracking pressure (bar)	O-Ring on pilot piston	
SC000002	CDPN-030-PSNE-07-028-N005	4,5	YES	
SC000044	CDPN-030-PSNN-07-028-N005	4,5	NO	

PILOT OPERATED CHECK VALVE

CDPN-050-PSNN

SEPARATE PILOT
PISTON

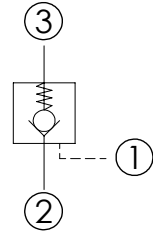
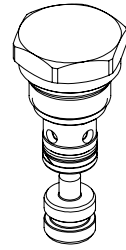
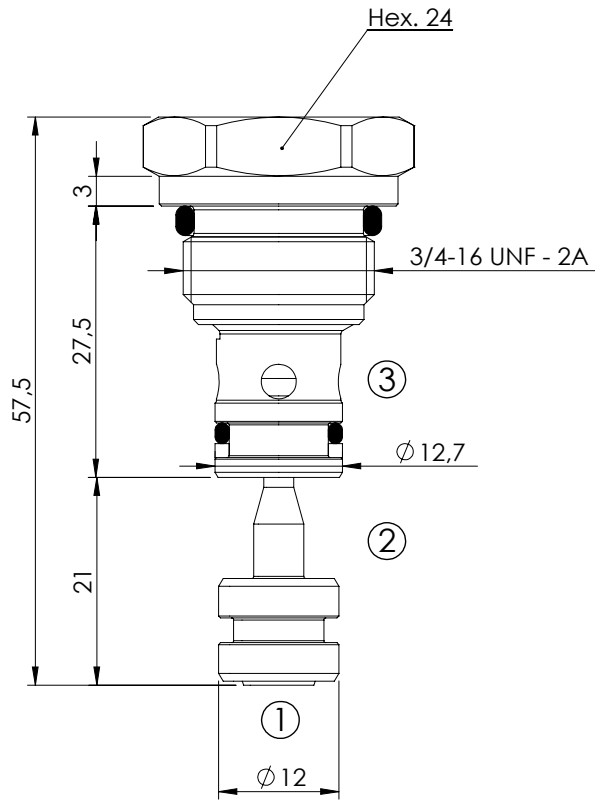

SPECIFICATIONS

Max. operating pressure:	350 bar
Rated flow:	50 l/min
Cavity:	VP000193
Weight:	0,07 kg
Pilot ratio:	4:1

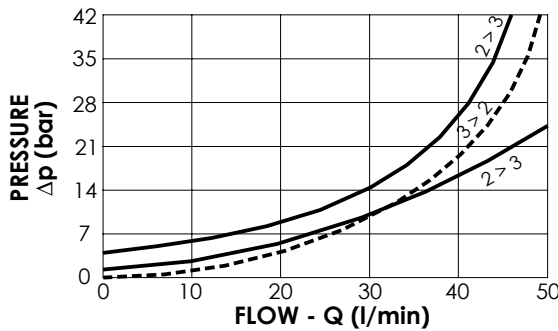

NOTES

Installation torque:	45 - 50 Nm
Seal kit:	RC700193

ORDERING CODES

Quick code	Description	Cracking pressure (bar)	O-Ring on pilot piston	
SC000051	CDPN-050-PSNN-04-193-N001	1	NO	
SC000056	CDPN-050-PSNN-04-193-N003	3	NO	
SC000057	CDPN-050-PSNE-04-193-N003	3	YES	

PILOT OPERATED CHECK VALVE

CDPN-060-PSNN

SEPARATE PILOT
PISTON

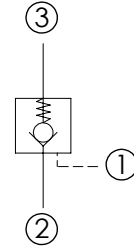
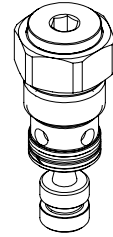
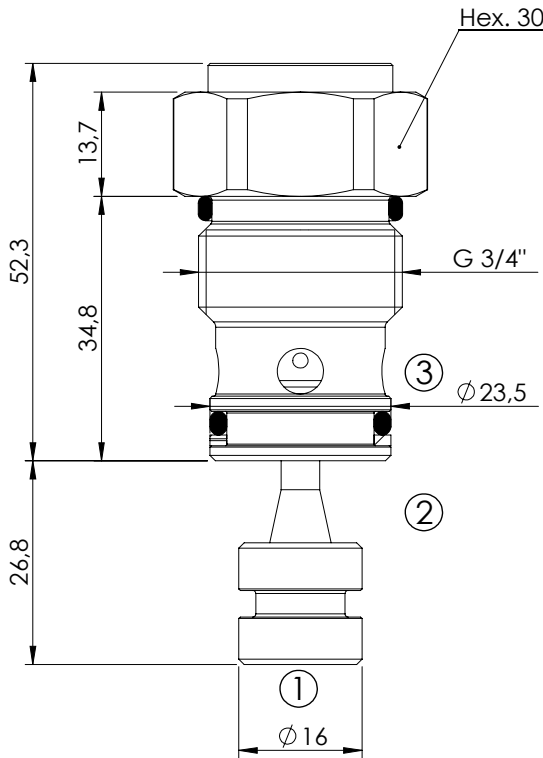

SPECIFICATIONS

Max. operating pressure:	350 bar
Rated flow:	60 l/min
Cavity:	VP000038
Weight:	0,2 kg
Pilot ratio:	3:1

NOTES

Installation torque:	100 - 130 Nm
Seal kit:	RC700038

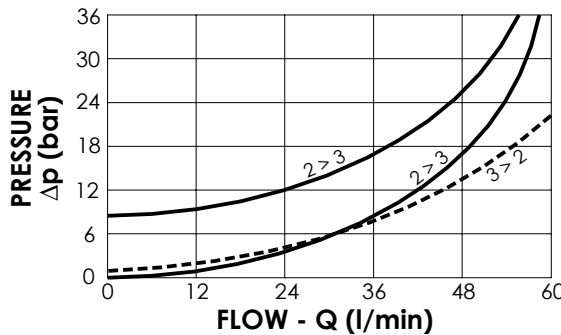

ORDERING CODES

Quick code	Description	Cracking pressure (bar)	O-Ring on pilot piston	
SC000052	CDPN-060-PSNN-03-038-N001	1	NO	
SC000054	CDPN-060-PSNN-03-038-N008	8	NO	
SC000055	CDPN-060-PSNE-03-038-N008	8	YES	

PILOT OPERATED CHECK VALVE

MCSN-020-SLAC

SINGLE ACTING

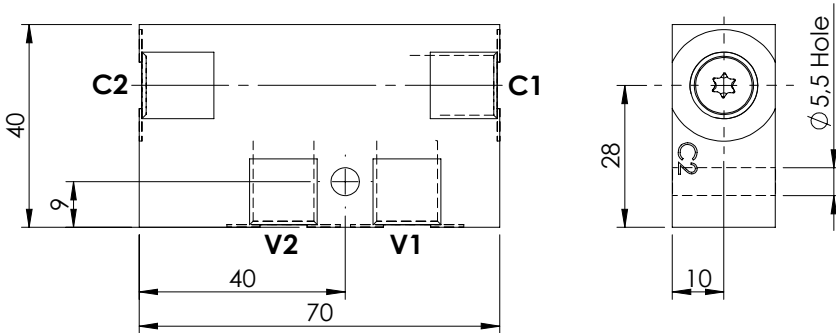
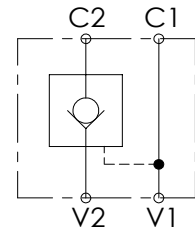
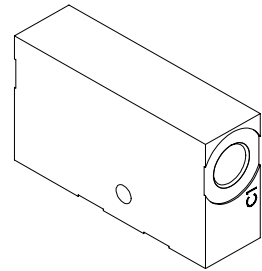
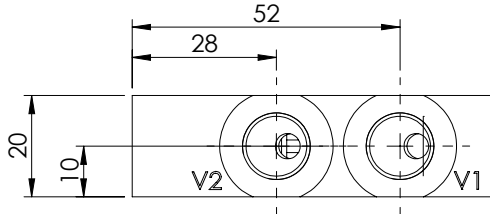

SPECIFICATIONS

Max. operating pressure:	350 bar
Rated flow:	20 l/min
Manifold:	Steel
Weight:	0,36 kg

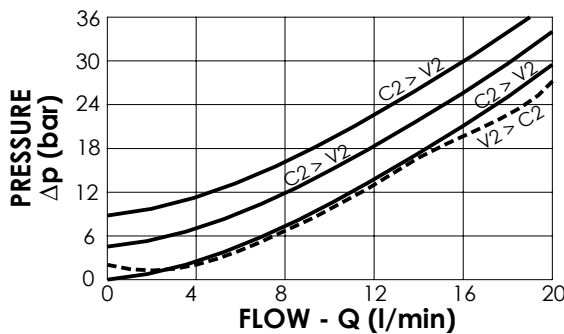

ORDERING CODES

Quick code	Description	Main ports size	Pilot ratio	Cracking pressure (bar)	O-Ring on pilot piston
MC000059	MCSN-020-SLAC-04-G14-N003	V1,V2,C1,C2 : G 1/4"	4:1	3	YES
MC000094	MCSN-020-SLAC-04-G14-N008	V1,V2,C1,C2 : G 1/4"	4:1	8	YES
MC000097	MCSN-020-SLAC-07-G14-N005	V1,V2,C1,C2 : G 1/4"	7:1	5	YES

PILOT OPERATED CHECK VALVE

MCSN-030-TLNS

SINGLE ACTING

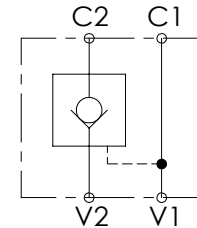
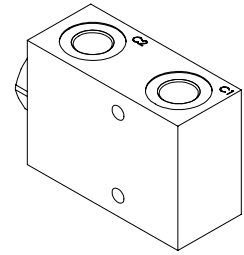
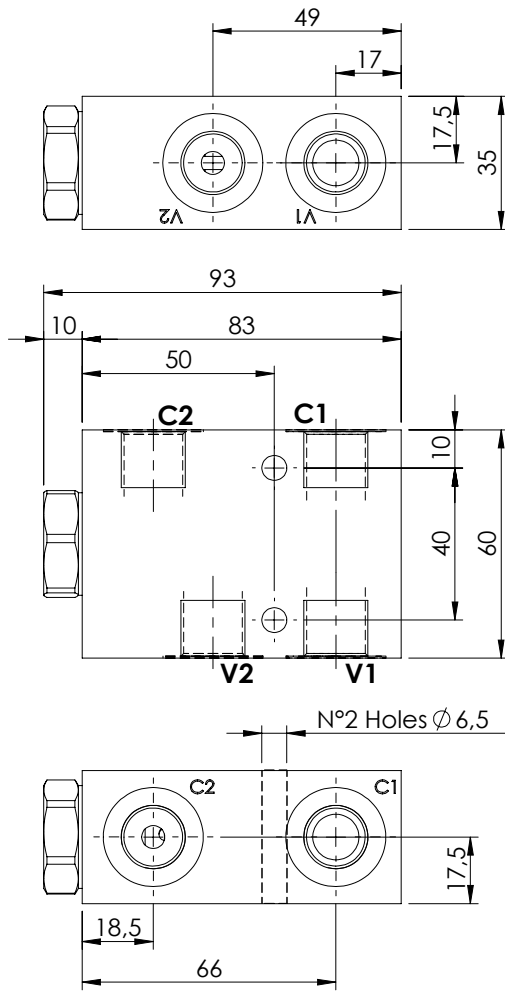

SPECIFICATIONS

Max. operating pressure:	350 bar
Rated flow:	30 l/min
Manifold:	Aluminium
Weight:	0,49 kg

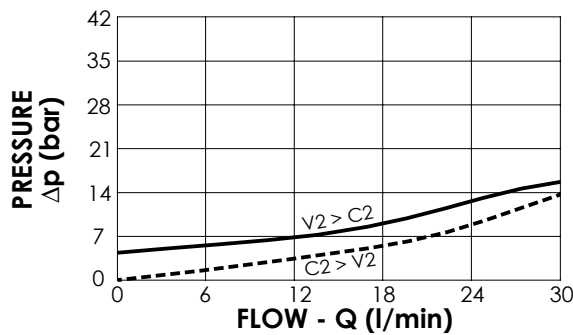

ORDERING CODES

Quick code	Description	Main ports size	Pilot ratio	Cracking pressure (bar)	O-Ring on pilot piston
MC000078	MCSN-030-TLNS-07-G38-N005	V1,V2,C1,C2 : G 3/8"	7:1	5	NO
MC000075	MCSN-030-TLNC-07-G38-N005	V1,V2,C1,C2 : G 3/8"	7:1	5	YES

PILOT OPERATED CHECK VALVE

MCSN-030-TANS

SINGLE ACTING
ONE FLANGED PORT

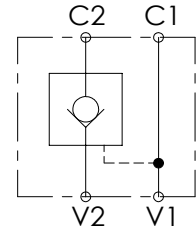
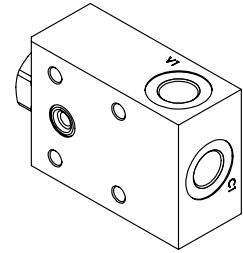
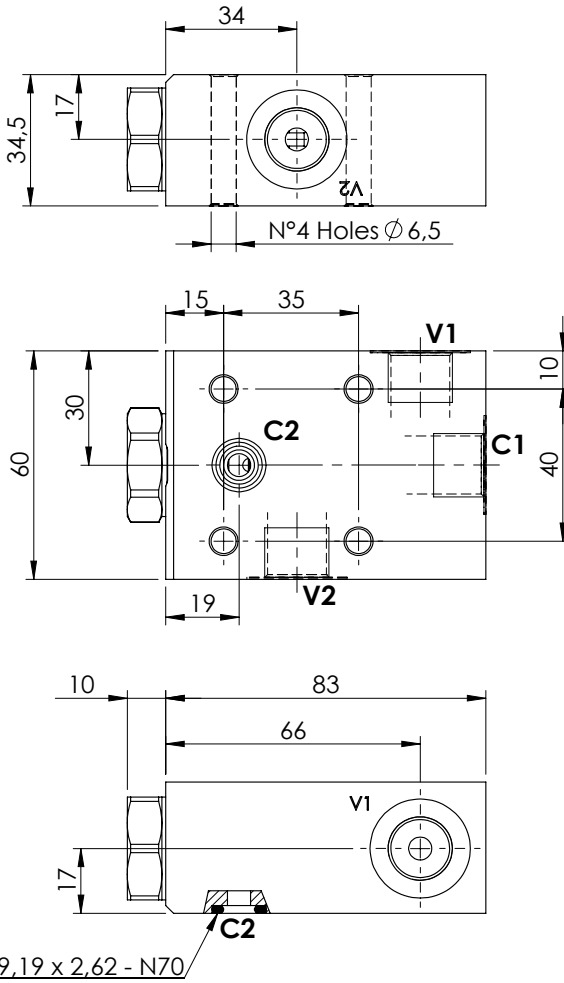

SPECIFICATIONS

Max. operating pressure:	350 bar
Rated flow:	30 l/min
Manifold:	Aluminium
Weight:	0,49 kg

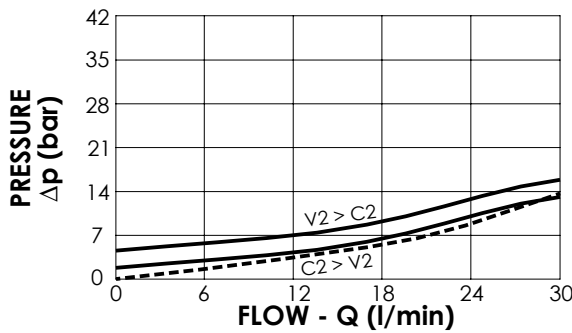

ORDERING CODES

Quick code	Description	Main ports size	Pilot ratio	Cracking pressure (bar)	O-Ring on pilot piston
MC000064	MCSN-030-TANS-07-G38-N001	V1,V2,C1: G 3/8" C2: Ø 6	7:1	1	NO
MC000066	MCSN-030-TANS-07-G38-N005	V1,V2,C1: G 3/8" C2: Ø 6	7:1	5	NO
MC000068	MCSN-030-TANC-07-G38-N005	V1,V2,C1: G 3/8" C2: Ø 6	7:1	5	YES

PILOT OPERATED CHECK VALVE

MCSN-060-TLNS

SINGLE ACTING

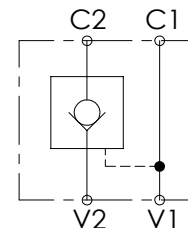
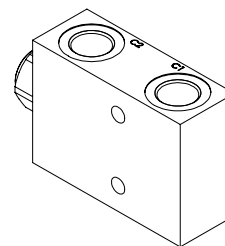
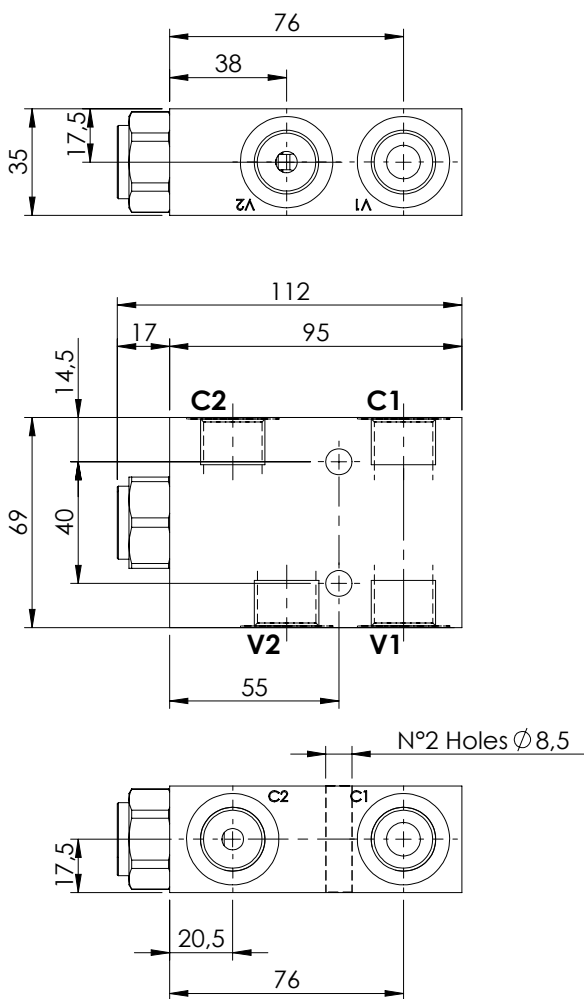

SPECIFICATIONS

Max. operating pressure:	350 bar
Rated flow:	60 l/min
Manifold:	Aluminium
Weight:	0,66 kg

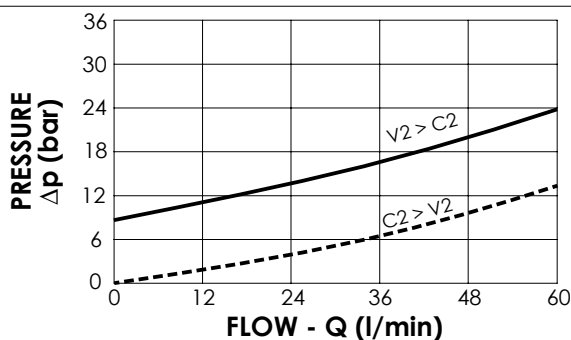

ORDERING CODES

Quick code	Description	Main ports size	Pilot ratio	Cracking pressure (bar)	O-Ring on pilot piston
MC000079	MCSN-060-TLNS-03-G12-N008	V1,V2,C1,C2 : G 1/2"	3:1	8	NO
MC000076	MCSN-060-TLNC-03-G12-N008	V1,V2,C1,C2 : G 1/2"	3:1	8	YES

PILOT OPERATED CHECK VALVE

MCSN-060-TANS

**SINGLE ACTING
ONE FLANGED PORT**

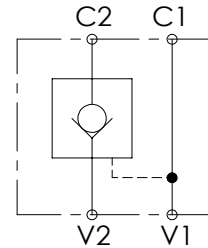
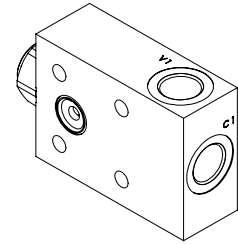
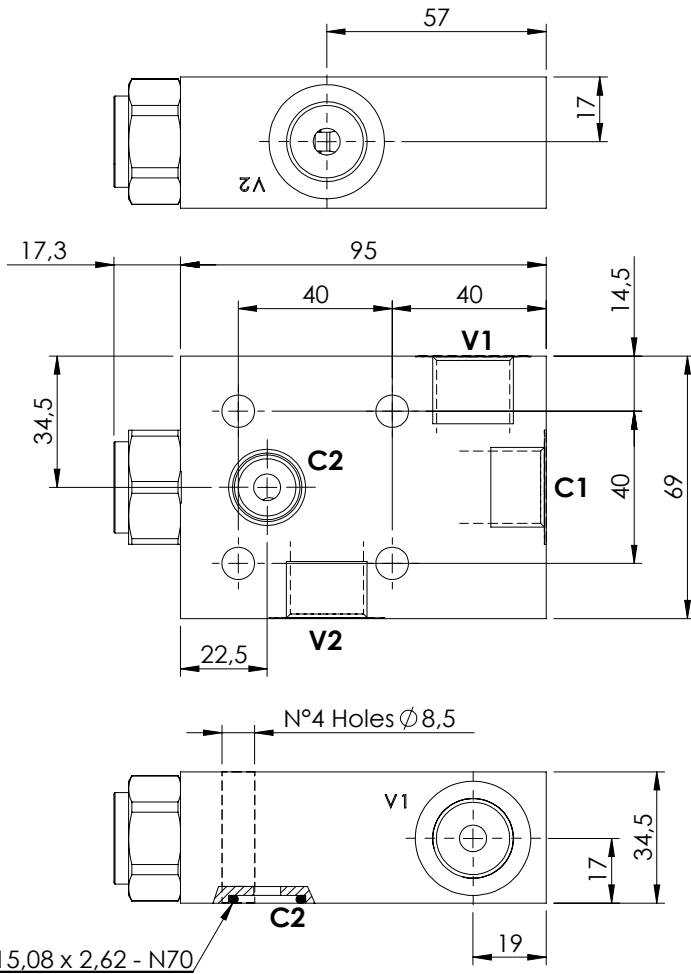

SPECIFICATIONS

Max. operating pressure:	350 bar
Rated flow:	60 l/min
Manifold:	Aluminium
Weight:	0,66 kg

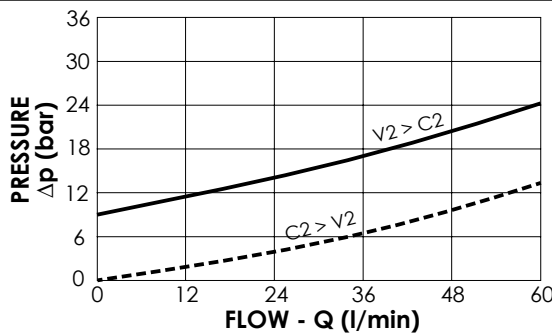

ORDERING CODES

Quick code	Description	Main ports size	Pilot ratio	Cracking pressure (bar)	O-Ring on pilot piston
MC000080	MCSN-060-TANS-03-G12-N008	V1,V2,C1: G 1/2" C2: Ø 7	3:1	8	NO
MC000077	MCSN-060-TANC-03-G12-N008	V1,V2,C1: G 1/2" C2: Ø 7	3:1	8	YES

PILOT OPERATED CHECK VALVE

MCSN-100-TLNS

SINGLE ACTING

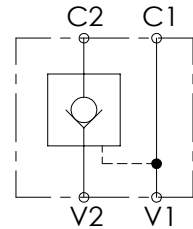
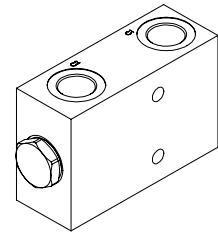
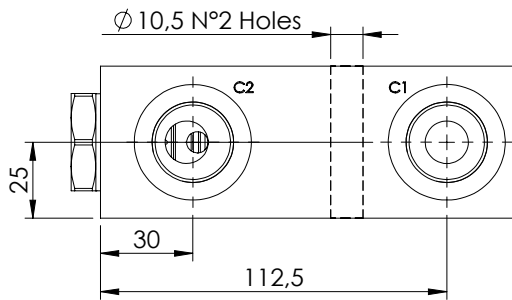
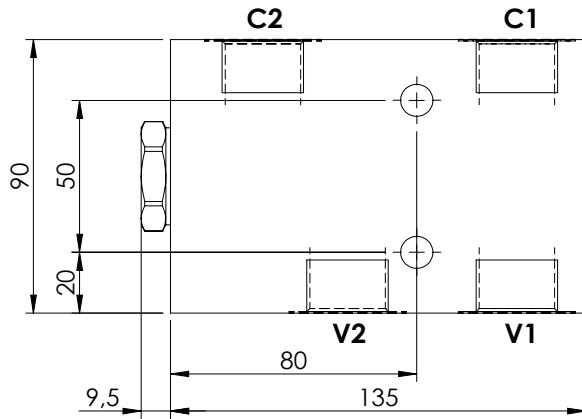
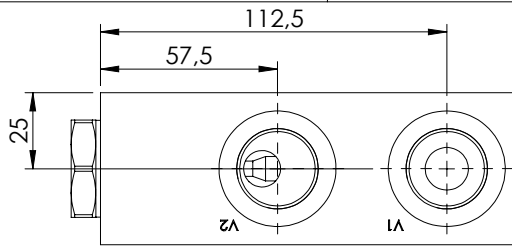

SPECIFICATIONS

Max. operating pressure:	350 bar
Rated flow:	100 l/min
Manifold:	Aluminium
Weight:	1,5 kg

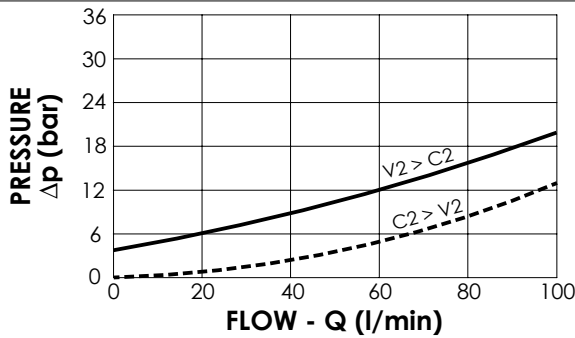

ORDERING CODES

Quick code	Description	Main ports size	Pilot ratio	Cracking pressure (bar)	O-Ring on pilot piston
MC000148	MCSN-100-TLNS-04-G34-N004	V1,V2,C1,C2 : G 3/4"	4:1	4	NO

PILOT OPERATED CHECK VALVE

MCSN-020-TLLC

**SINGLE ACTING
MANUAL SHUT OFF
LEFT VERSION**

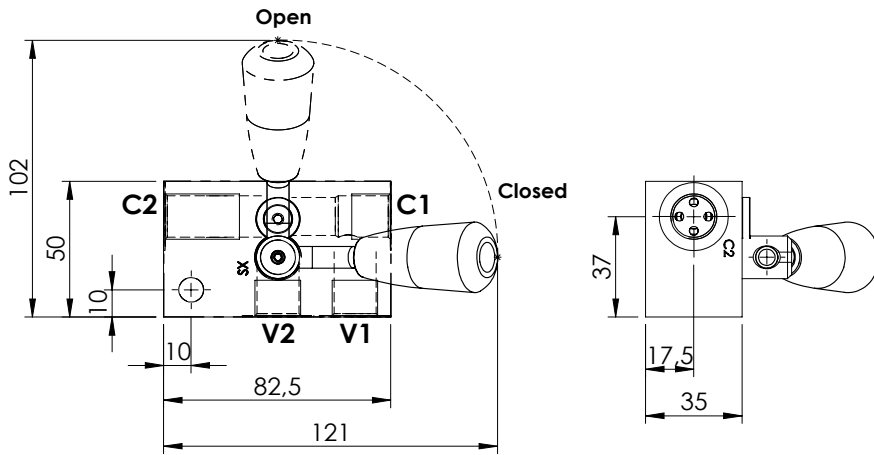
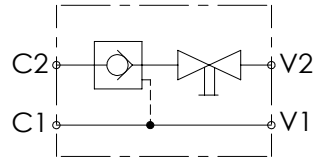
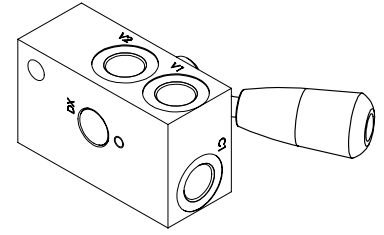
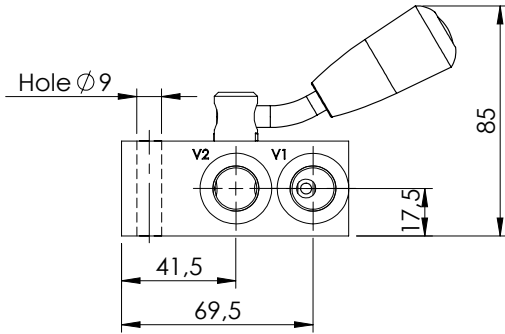

SPECIFICATIONS

Max. operating pressure:	350 bar
Rated flow:	20 l/min
Manifold:	Aluminium
Weight:	0,45 kg

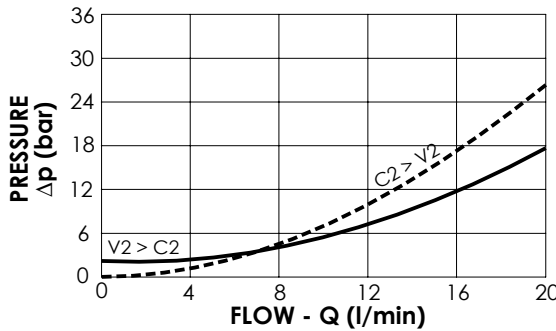

ORDERING CODES

Quick code	Description	Main ports size	Pilot ratio	Cracking pressure (bar)	O-Ring on pilot piston
MC000062	MCSN-020-TLLC-05-G38-N002	V1,V2,C1,C2 : G 3/8"	5:1	2	YES

PILOT OPERATED CHECK VALVE

MCSN-020-TLRC

**SINGLE ACTING
MANUAL SHUT OFF
RIGHT VERSION**

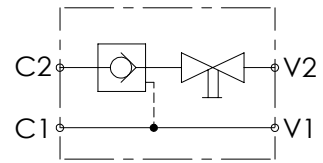
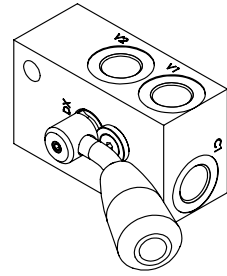
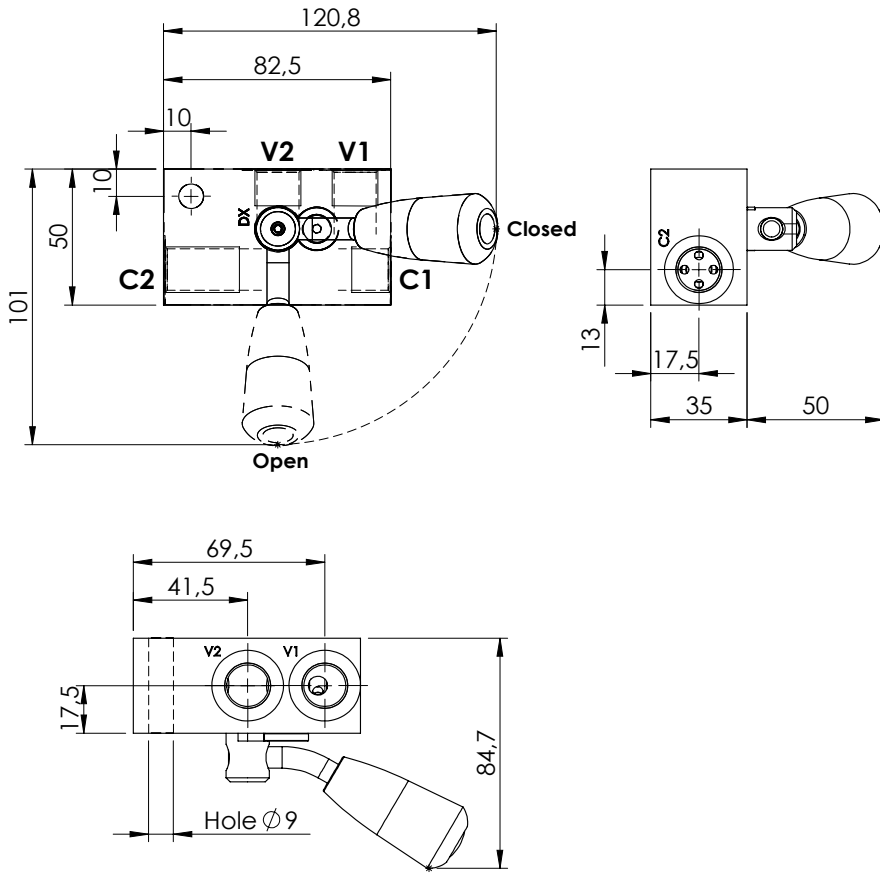

SPECIFICATIONS

Max. operating pressure:	350 bar
Rated flow:	20 l/min
Manifold:	Aluminium
Weight:	0,45 kg

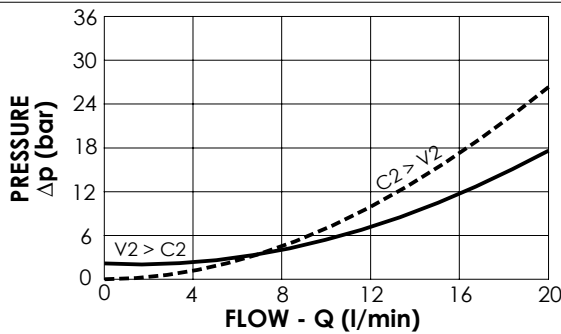

ORDERING CODES

Quick code	Description	Main ports size	Pilot ratio	Cracking pressure (bar)	O-Ring on pilot piston
MC000061	MCSN-020-TLRC-05-G38-N002	V1,V2,C1,C2 : G 3/8"	5:1	2	YES

PILOT OPERATED CHECK VALVE

MCDN-020-SLAS

DOUBLE ACTING

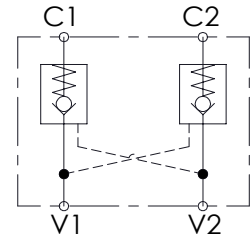
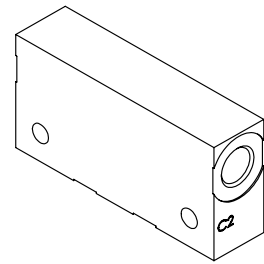
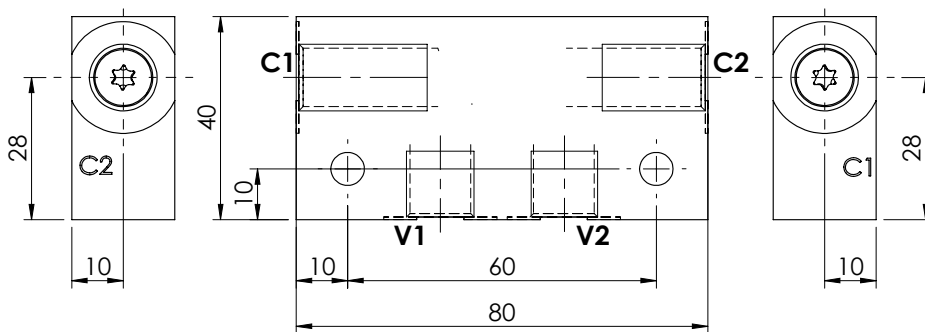
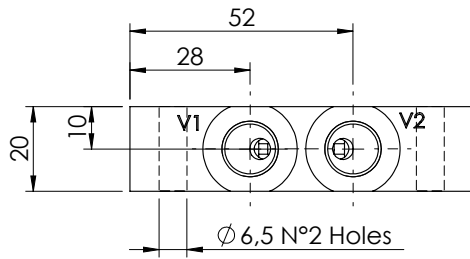

SPECIFICATIONS

Max. operating pressure:	350 bar
Rated flow:	20 l/min
Manifold:	Steel
Weight:	0,42 kg

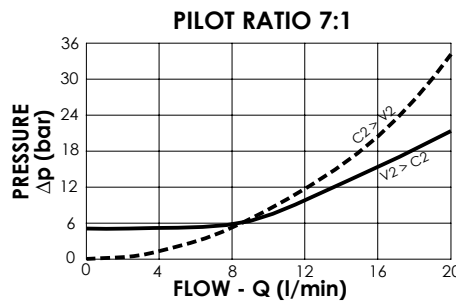
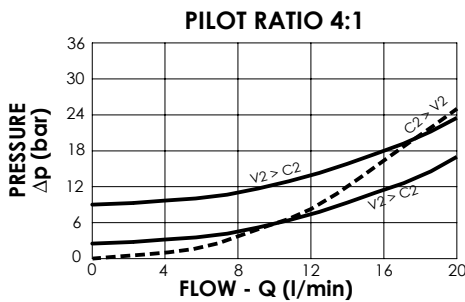

ORDERING CODES

Quick code	Description	Main ports size	Pilot ratio	Cracking pressure (bar)	O-Ring on pilot piston
MC000113	MCDN-020-SLAS-04-G14-N003	V1,V2,C1,C2 : G 1/4"	4:1	3	NO
MC000160	MCDN-020-SLAS-04-G14-N008	V1,V2,C1,C2 : G 1/4"	4:1	8	NO
MC000227	MCDN-020-SLAS-07-G14-N005	V1,V2,C1,C2 : G 1/4"	7:1	5	NO

PILOT OPERATED CHECK VALVE

MCDN-020-SLAS

DOUBLE ACTING

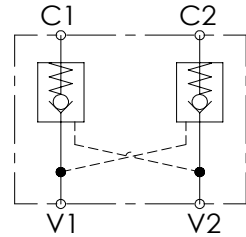
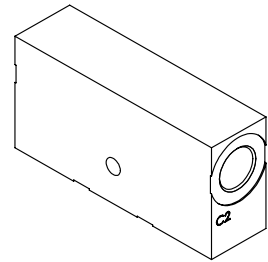
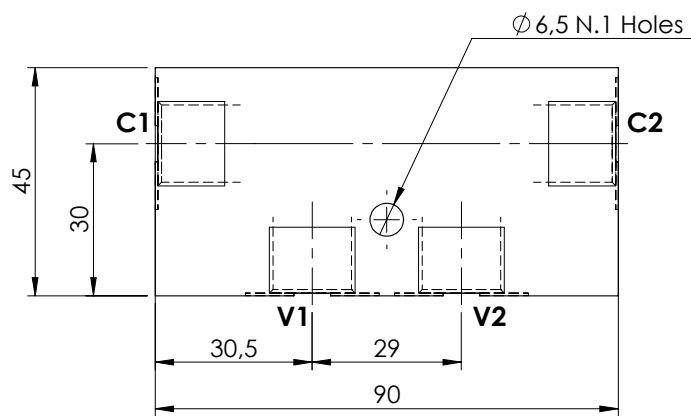
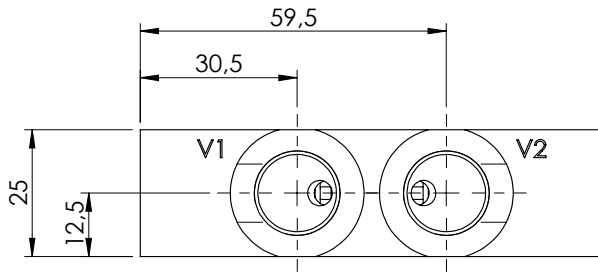

SPECIFICATIONS

Max. operating pressure:	350 bar
Rated flow:	20 l/min
Manifold:	Steel
Weight:	0,67 kg

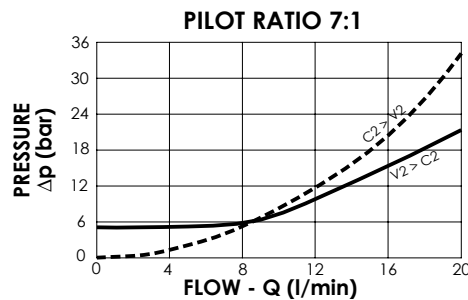
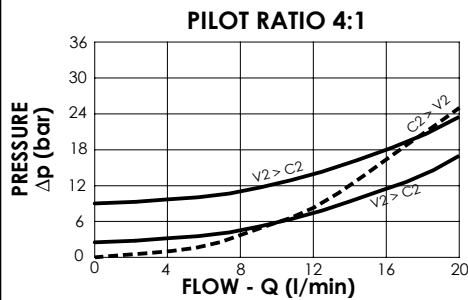

ORDERING CODES

Quick code	Description	Main ports size	Pilot ratio	Cracking pressure (bar)	O-Ring on pilot piston
MC000174	MCDN-020-SLAS-04-G38-N003	V1,V2,C1,C2 : G 3/8"	4:1	3	NO
MC000213	MCDN-020-SLAS-04-G38-N009	V1,V2,C1,C2 : G 3/8"	4:1	9	NO
MC000212	MCDN-020-SLAS-04-G38-N005	V1,V2,C1,C2 : G 3/8"	7:1	5	NO

PILOT OPERATED CHECK VALVE

MCDN-020-SLGS

**DOUBLE ACTING
WITH BANJO**

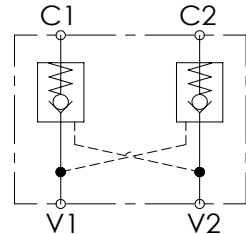
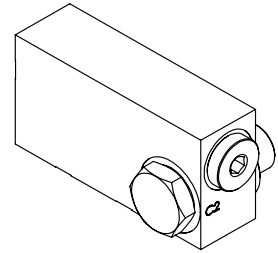
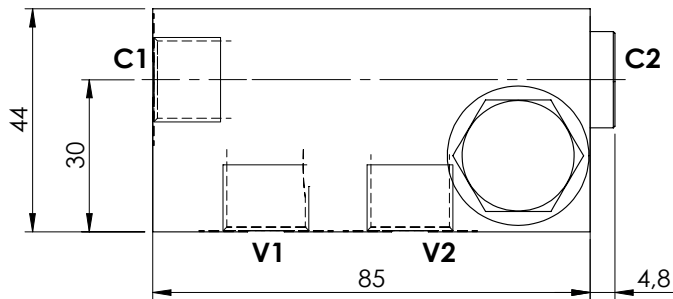
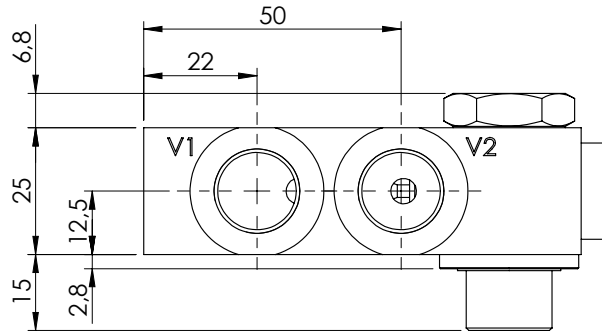

SPECIFICATIONS

Max. operating pressure:	350 bar
Rated flow:	20 l/min
Manifold:	Steel
Weight:	0,68 kg

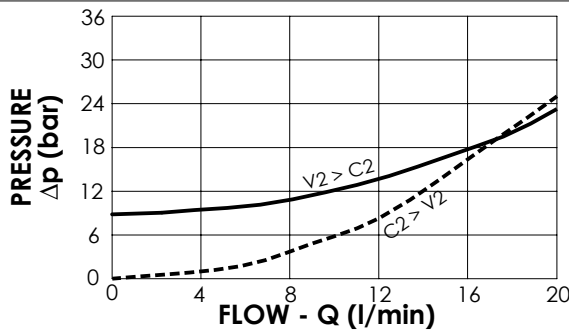

ORDERING CODES

Quick code	Description	Main ports size	Pilot ratio	Cracking pressure (bar)	O-Ring on pilot piston
MC000208	MCDN-020-SLGS-04-G38-N010	V1,V2,C1,C2 : G 3/8"	4:1	10	NO

PILOT OPERATED CHECK VALVE

MCDN-030-TLNS

DOUBLE ACTING

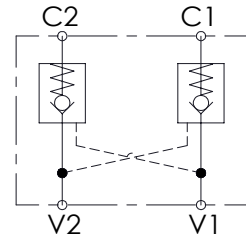
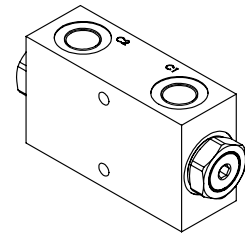
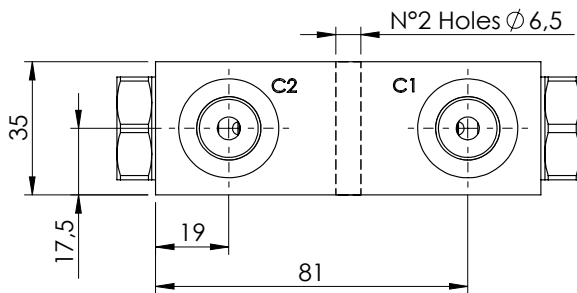
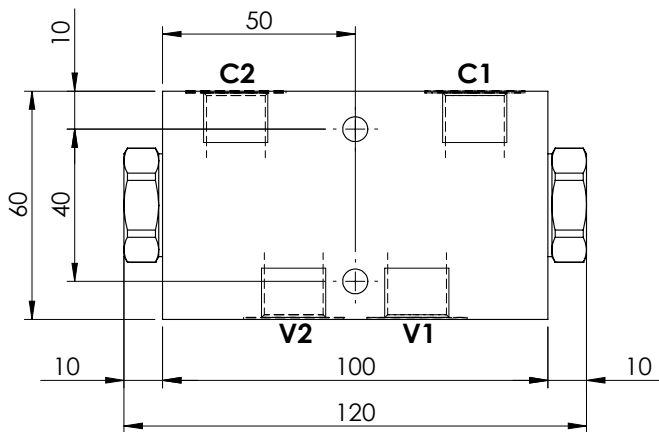
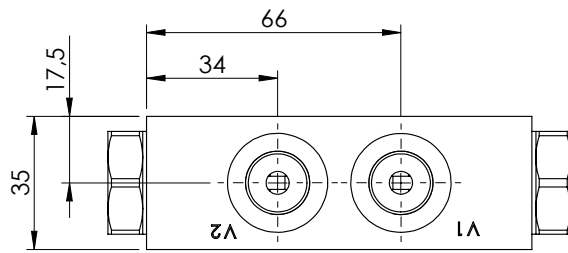

SPECIFICATIONS

Max. operating pressure:	350 bar
Rated flow:	30 l/min
Manifold:	Aluminium
Weight:	0,67 kg

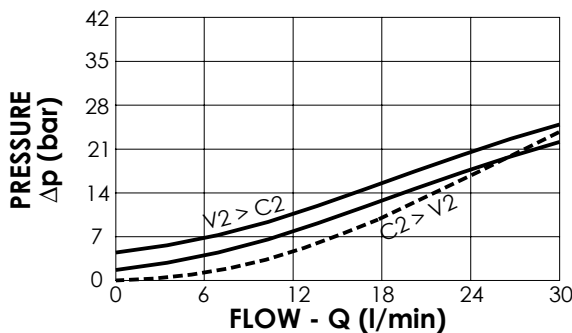

ORDERING CODES

Quick code	Description	Main ports size	Pilot ratio	Cracking pressure (bar)	O-Ring on pilot piston
MC000002	MCDN-030-TLNS-07-G38-N001	V1,V2,C1,C2 : G 3/8"	7:1	1	NO
MC000009	MCDN-030-TLNS-07-G38-N005	V1,V2,C1,C2 : G 3/8"	7:1	5	NO
MC000010	MCDN-030-TLNC-07-G38-N005	V1,V2,C1,C2 : G 3/8"	7:1	5	YES

PILOT OPERATED CHECK VALVE

MCDN-030-ZBNS

DOUBLE ACTING
TWO FLANGED PORTS

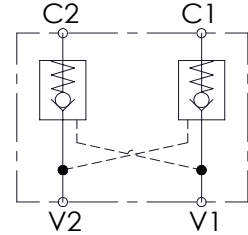
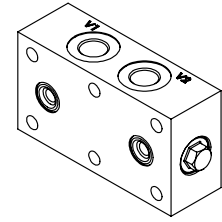
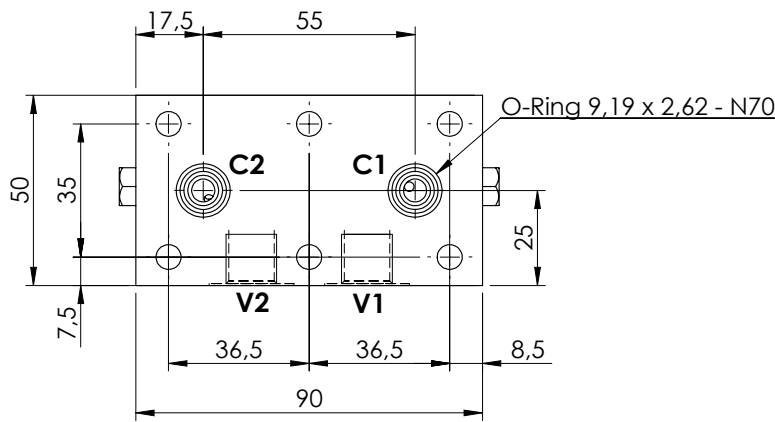
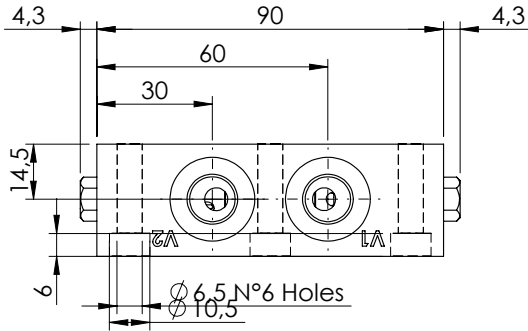

SPECIFICATIONS

Max. operating pressure:	350 bar
Rated flow:	30 l/min
Manifold:	Aluminium
Weight:	0,67 kg

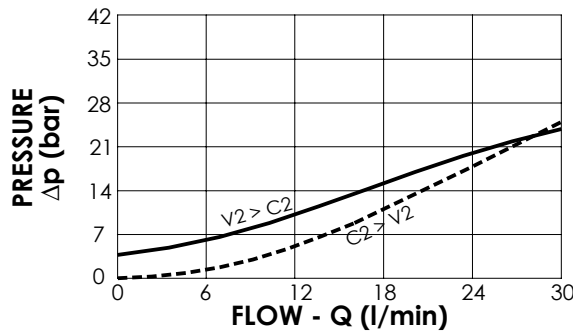

ORDERING CODES

Quick code	Description	Main ports size	Pilot ratio	Cracking pressure (bar)	O-Ring on pilot piston
MC000086	MCDN-030-ZBNS-04-G14-N004	V1,V2:G 1/4" C1,C2: Ø 6	4:1	4	NO

PILOT OPERATED CHECK VALVE

MCDN-030-TBNS

DOUBLE ACTING
TWO FLANGED PORTS

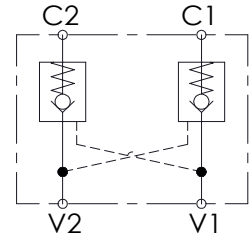
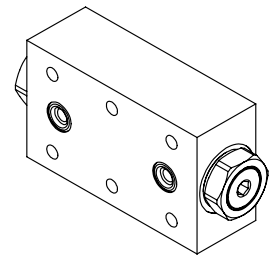
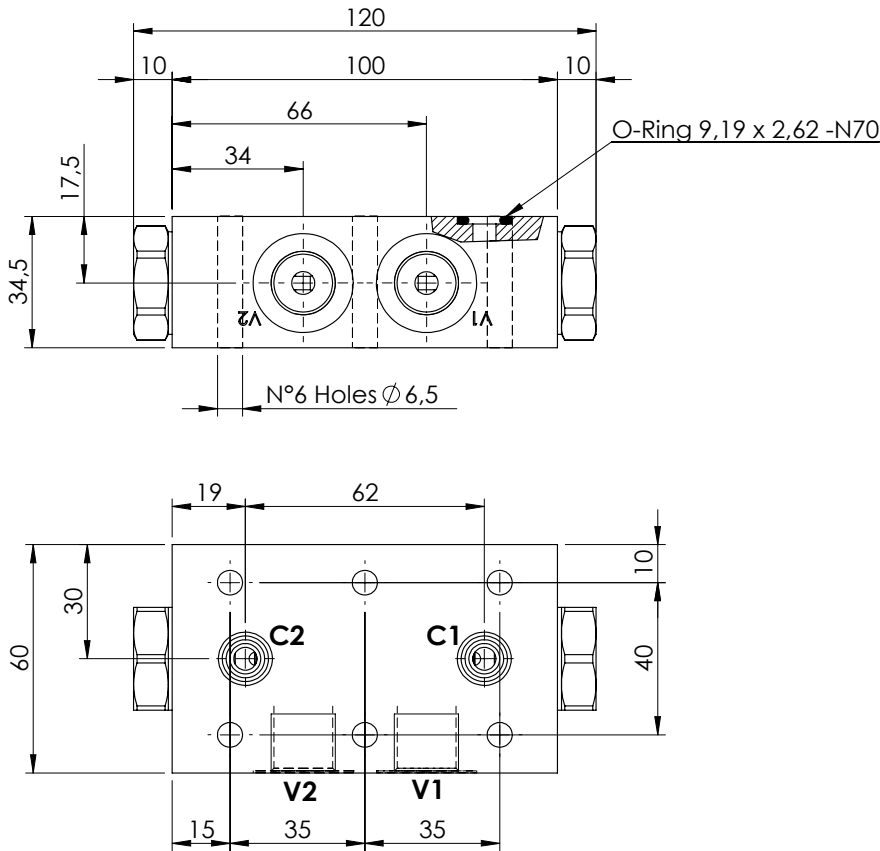

SPECIFICATIONS

Max. operating pressure:	350 bar
Rated flow:	30 l/min
Manifold:	Aluminium
Weight:	0,67 kg

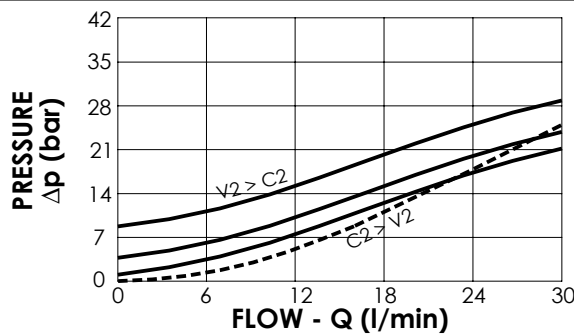

ORDERING CODES

Quick code	Description	Main ports size	Pilot ratio	Cracking pressure (bar)	O-Ring on pilot piston
MC000005	MCDN-030-TBNS-07-G38-N001	V1,V2:G 3/8" C1,C2: Ø 6	7:1	1	NO
MC000012	MCDN-030-TBNS-07-G38-N005	V1,V2:G 3/8" C1,C2: Ø 6	7:1	5	NO
MC000020	MCDN-030-TBNC-07-G38-N005	V1,V2:G 3/8" C1,C2: Ø 6	7:1	5	YES
MC000092	MCDN-030-TBNS-07-G38-N009	V1,V2:G 3/8" C1,C2: Ø 6	7:1	9	NO
MC000195	MCDN-030-TBNC-07-G38-N009	V1,V2:G 3/8" C1,C2: Ø 6	7:1	9	YES

PILOT OPERATED CHECK VALVE

MCDN-030-SBNS

**DOUBLE ACTING
TWO FLANGED PORTS**

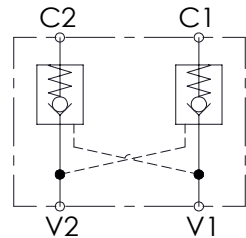
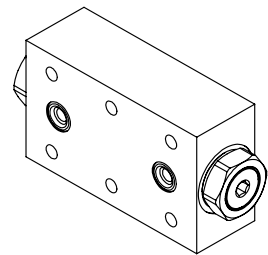
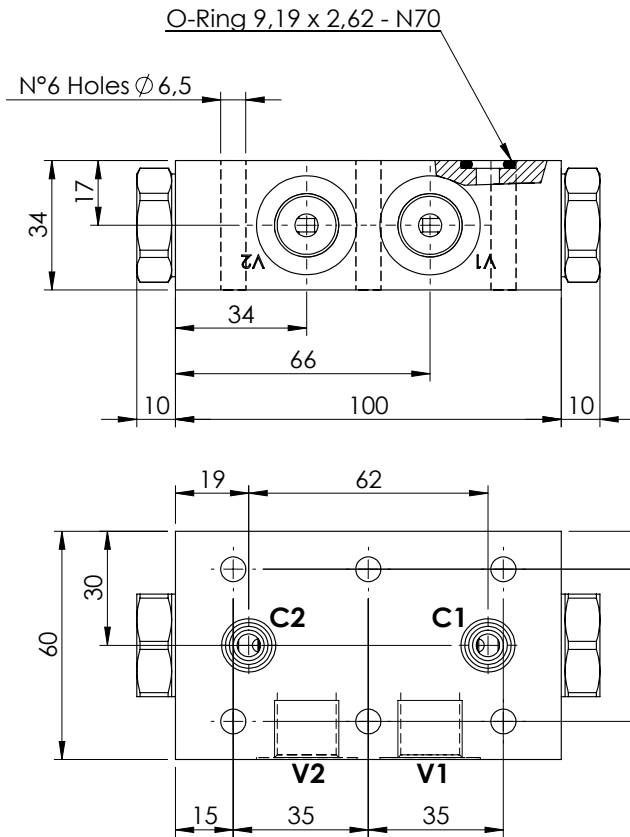

SPECIFICATIONS

Max. operating pressure:	350 bar
Rated flow:	30 l/min
Manifold:	Steel
Weight:	1,49 kg

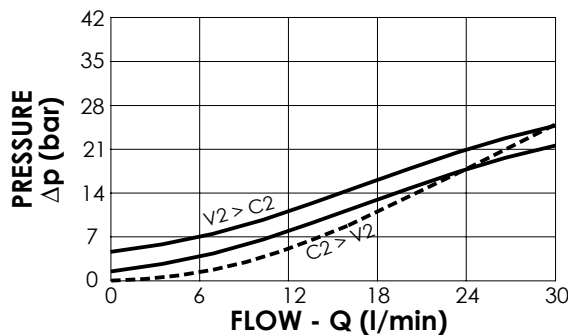

ORDERING CODES

Quick code	Description	Main ports size	Pilot ratio	Cracking pressure (bar)	O-Ring on pilot piston
MC000036	MCDN-030-SBNS-07-G38-N005	V1,V2:G 3/8" C1,C2:Ø 6	7:1	5	NO
MC000037	MCDN-030-SBNC-07-G38-N005	V1,V2:G 3/8" C1,C2:Ø 6	7:1	5	YES
MC000038	MCDN-030-SBNS-07-G38-N001	V1,V2:G 3/8" C1,C2:Ø 6	7:1	1	NO

PILOT OPERATED CHECK VALVE

MCDN-060-TLNS

DOUBLE ACTING

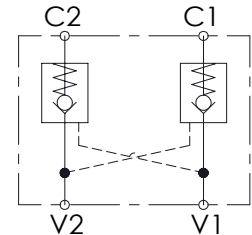
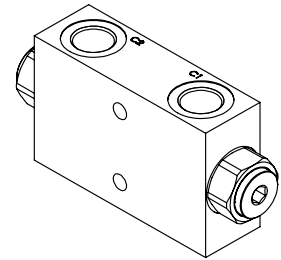
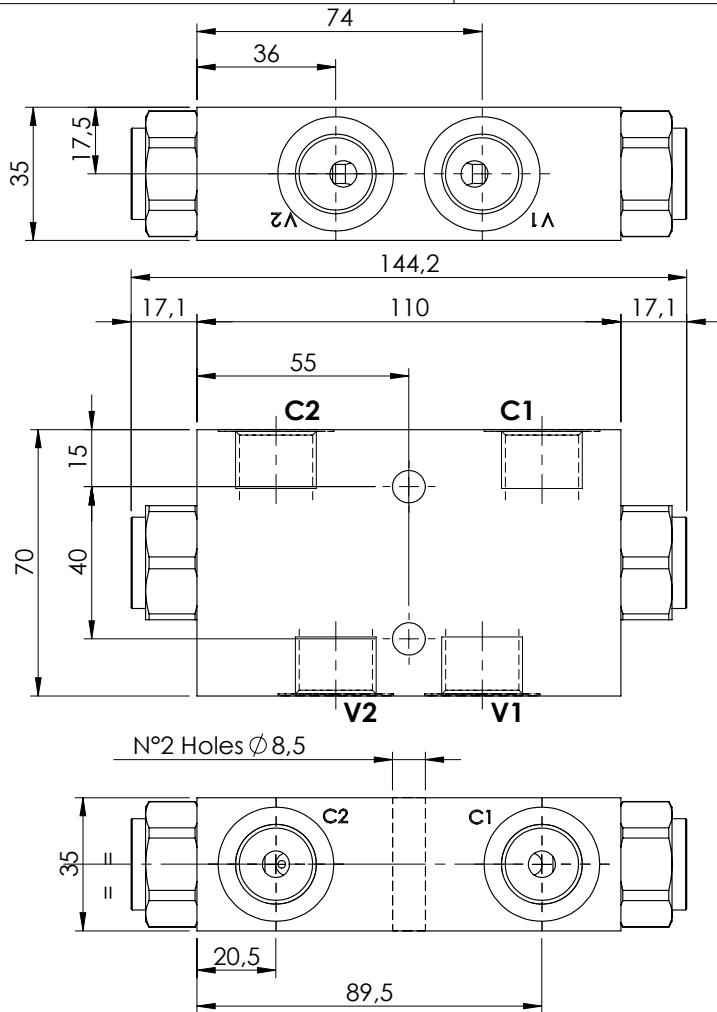

SPECIFICATIONS

Max. operating pressure:	350 bar
Rated flow:	60 l/min
Manifold:	Aluminium
Weight:	0,9 kg

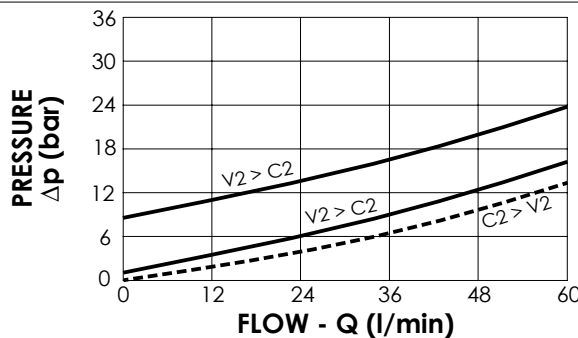

ORDERING CODES

Quick code	Description	Main ports size	Pilot ratio	Cracking pressure (bar)	O-Ring on pilot piston
MC000042	MCDN-060-TLNS-03-G12-N001	V1,V2,C1,C2 : G1/2"	3:1	1	NO
MC000040	MCDN-060-TLNS-03-G12-N008	V1,V2,C1,C2 : G1/2"	3:1	8	NO
MC000041	MCDN-060-TLNC-03-G12-N008	V1,V2,C1,C2 : G1/2"	3:1	8	YES

PILOT OPERATED CHECK VALVE

MCDN-060-TBNS

**DOUBLE ACTING
TWO FLANGED PORTS**

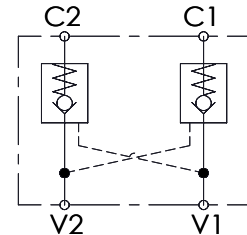
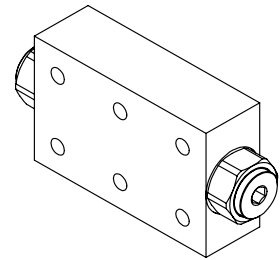
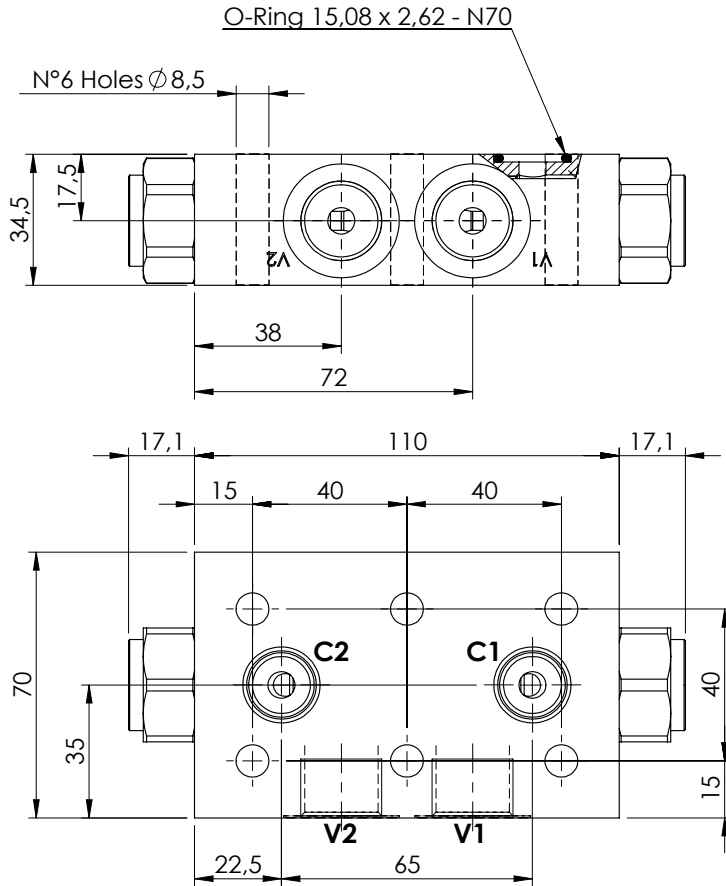

SPECIFICATIONS

Max. operating pressure:	350 bar
Rated flow:	60 l/min
Manifold:	Aluminium
Weight:	0,90 kg

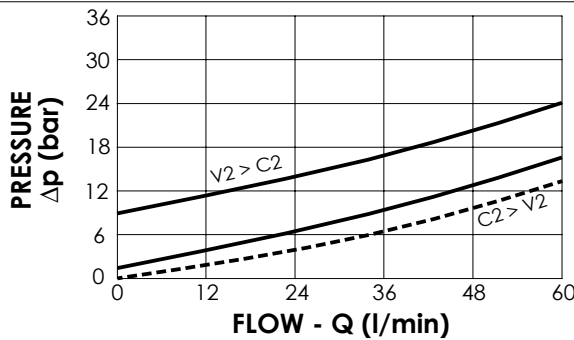

ORDERING CODES

Quick code	Description	Main ports size	Pilot ratio	Cracking pressure (bar)	O-Ring on pilot piston
MC000029	MCDN-060-TBNS-03-G12-N001	V1,V2:G 1/2" C1,C2: Ø 7	3:1	1	NO
MC000027	MCDN-060-TBNS-03-G12-N008	V1,V2:G 1/2" C1,C2: Ø 7	3:1	8	NO
MC000028	MCDN-060-TBNC-03-G12-N008	V1,V2:G 1/2" C1,C2: Ø 7	3:1	8	YES
MC000026	MCDN-060-TBNS-06-G12-N001	V1,V2:G 1/2" C1,C2: Ø 7	6:1	1	NO
MC000025	MCDN-060-TBNS-06-G12-N008	V1,V2:G 1/2" C1,C2: Ø 7	6:1	8	NO
MC000022	MCDN-060-TBNC-06-G12-N008	V1,V2:G 1/2" C1,C2: Ø 7	6:1	8	YES

PILOT OPERATED CHECK VALVE

MCDN-100-LLNR

DOUBLE ACTING

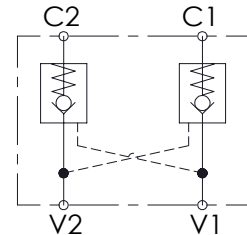
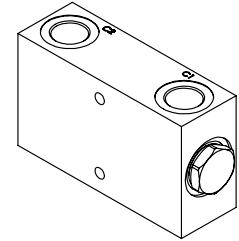
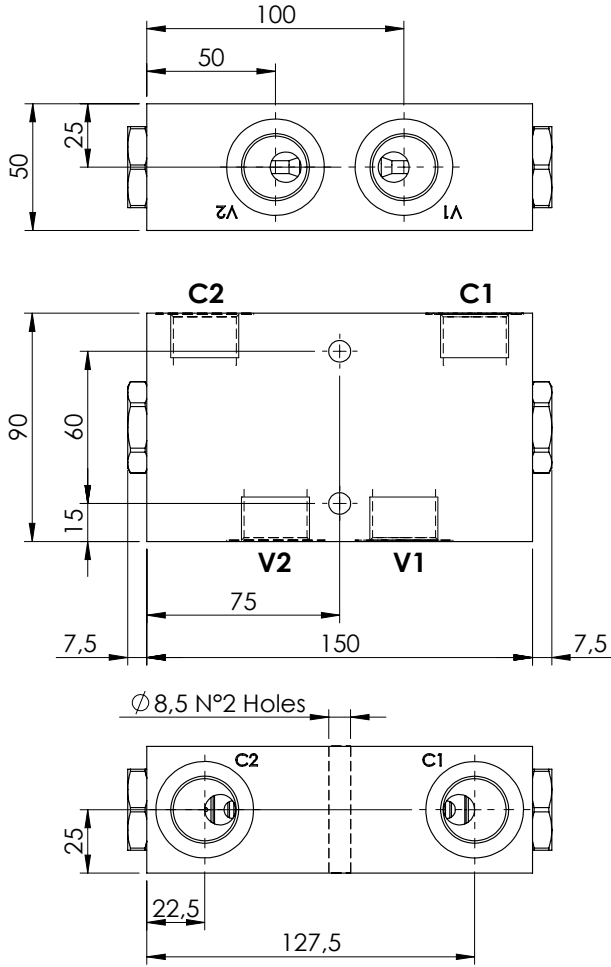

SPECIFICATIONS

Max. operating pressure:	350 bar
Rated flow:	100 l/min
Manifold:	Aluminium
Weight:	1,8 kg

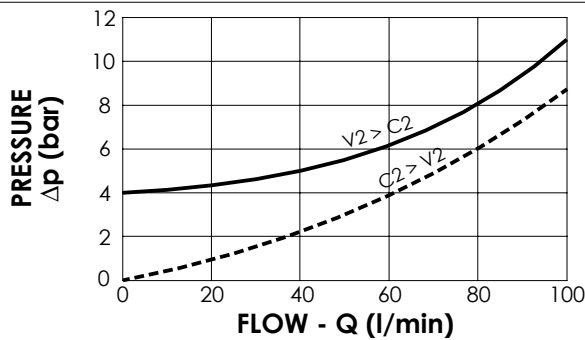

ORDERING CODES

Quick code	Description	Main ports size	Pilot ratio	Cracking pressure (bar)	O-Ring on pilot piston
MC000144	MCDN-100-LLNR-04-G34-N004	V1,V2,C1,C2 : G3/4"	4:1	4	NO



ATLANTIC
Fluid Tech

SECTION 6

Overcenter Valves



1800-OILSOL
1800-645765

<https://oilsolutions.com.au/>

sales@oilsolutions.com.au

SECTION 6

OVERCENTRE VALVES



Hydraulic scheme	Valve description	Valve type	Rated flow (l/min)	Max. pressure (bar)	Installation	Main port size or cavity type	Page
	CBSN-030-PARH	Poppet type	30	350	Cartridge	SAE-08-3C	6.01.010
	CBSN-040-DCNH	Differential area	40	350	Cartridge	VP000174	6.01.020
	CBSN-060-DARH	Poppet type, differential area	60	350	Cartridge	SAE-10-3C	6.01.030
	CBSN-060-DSRH	Poppet type, differential area	60	350	Cartridge	VP000161 (T-11A)	6.01.040
	CBSN-060-DCNH	Differential area	60	350	Cartridge	VP000121	6.01.050
	CBSN-100-DCNH	Differential area	100	350	Cartridge	VP000120	6.01.060
	CBSN-120-DSRH	Poppet type, differential area	120	350	Cartridge	VP000165 (T-2A)	6.01.070
	CBSN-120-DAGH	Poppet type, differential area	120	350	Cartridge	SAE-12-3C	6.01.080
	CBSN-150-DCNH	Differential area	150	350	Cartridge	VP000128	6.01.090
	CBSN-240-DSGH	Poppet type, differential area	240	420	Cartridge	VP000166 (T-17A)	6.01.100
	CBSN-300-DCNH	Differential area	300	350	Cartridge	VP000127	6.01.110
	CBSN-320-DARH	Poppet type, differential area	320	420	Cartridge	SAE-20-3C	6.01.120
	CBST-030-PARH	Poppet type, fully compensated	30	350	Cartridge	SAE-08-3C	6.03.130
	CBST-040-DCNH	Differential area, relief and pilot compensated	40	350	Cartridge	VP000174	6.03.140
	CBST-100-DCNH	Differential area, relief and pilot compensated	100	350	Cartridge	VP000120	6.03.150
	CBST-150-DCNH	Differential area, relief and pilot compensated	150	350	Cartridge	VP000128	6.03.160
	CBST-300-DCNH	Differential area, relief and pilot compensated	300	350	Cartridge	VP000127	6.03.170
	MBSN-040-ALNP	Single acting	40	350	In line	G 1/4"	6.04.180
	MBSN-040-ZLNA	Single acting	40	350	In line	G 3/8"	6.04.190
	MBSN-040-AANP	Single acting, one flanged ports	40	350	In line	G 1/4"	6.04.200
	MBSN-040-ZDNA	Single acting, all flanged ports	40	350	In line	Ø 8	6.04.210
	MBSN-040-APNR	Single acting, banjo mounting	40	350	In line	G 3/8"	6.04.220
	MBSN-060-ALNR	Single acting	60	350	In line	G 3/8"	6.04.230
	MBSN-060-ALNE	Single acting	60	350	In line	G 3/8"	6.04.240
	MBSN-060-ZLSE	Single acting	60	350	In line	G 1/2"	6.04.250
	MBSN-060-ALNE	Single acting	60	350	In line	G 1/2"	6.04.260
	MBSN-060-ZLNA	Single acting, in line ports	60	350	In line	G 1/2"	6.04.270
	MBSN-060-AANR	Single acting, one flanged port	60	350	Flanged	G 3/8"	6.04.280
	MBSN-060-AATV	Single acting, one flanged port	60	350	Flanged	G 3/8"	6.04.290
	MBSN-060-ABNP	Single acting, two flanged ports	60	350	Flanged	G 3/8"	6.04.300
	MBSN-060-ABNP	Single acting, two flanged ports	60	350	Flanged	G 1/2"	6.04.310
	MBSN-150-ALNV	Single acting	150	350	In line	G 1/2"	6.04.320
	MBSN-150-ALNV	Single acting	150	350	In line	G 3/4"	6.04.330
	MBSN-150-AANV	Single acting, one flanged port	150	350	Flanged	G 3/4"	6.04.340
	MBSN-150-ABNV	Single acting, two flanged ports	150	350	Flanged	G 1/2"	6.04.350
	MBSN-150-ABNV	Single acting, two flanged ports	150	350	Flanged	G 3/4"	6.04.360
	MBSN-300-ZLNP	Single acting	300	350	In line	G 1"	6.04.370

SECTION 6

OVERCENTRE VALVES



Hydraulic scheme	Valve description	Valve type	Rated flow (l/min)	Max. pressure (bar)	Installation	Main port size or cavity type	Page
	MBSP-060-ZLSE	Single acting, relief compensated	60	350	In line	G 3/8"	6.05.380
	MBSP-060-ALNP	Single acting, relief compensated	60	350	In line	G 3/8"	6.05.390
	MBSP-060-ALNE	Single acting, relief compensated	60	350	In line	G 1/2"	6.05.400
	MBSP-060-ABNP	Single acting, two flanged ports, relief compens.	60	350	Flanged	G 3/8"	6.05.410
	MBSP-060-ABNP	Single acting, two flanged ports, relief compens.	60	350	Flanged	G 1/2"	6.05.420
	MBSP-150-ZLSE	Single acting	150	350	In line	G 3/4"	6.05.430
	MBST-150-AANV	Single acting, one flanged port, relief compens.	150	350	Flanged	G 3/4"	6.06.440
	MBST-150-ABNV	Single acting, two flanged ports, fully compens.	150	350	Flanged	G 1/2"	6.06.450
	MBST-150-ABNV	Single acting, two flanged ports, fully compens.	150	350	Flanged	G 3/4"	6.06.460
	MBDN-040-ALNP	Double acting	40	350	In line	G 1/4"	6.07.470
	MBDN-040-ALNR	Double acting	40	350	In line	G 1/4"	6.07.480
	MBDN-040-ZLNN	Double acting	40	350	In line	G 3/8"	6.07.490
	MBDN-040-AANR	Double acting, one flanged port	40	350	Flanged	G 1/4"	6.07.500
	MBDN-040-ABNP	Double acting, two flanged ports	40	350	Flanged	G 1/4"	6.07.510
	MBDN-040-ABNR	Double acting, two flanged ports	40	350	Flanged	G 1/4"	6.07.520
	MBDN-040-ABNV	Double acting, two flanged ports	40	350	Flanged	G 3/8"	6.07.530
	MBDN-040-ZBNN	Double acting, two flanged ports	40	350	Flanged	G 3/8"	6.07.540
	MBDN-040-ZDNA	Double acting, all flanged ports	40	350	Flanged	Ø 8	6.07.550
	MBDN-060-ALNR	Double acting	60	350	In line	G 3/8"	6.07.560
	MBDN-060-ALNR	Double acting	60	350	In line	G 1/2"	6.07.570
	MBDN-060-ZLDE	Double acting	60	350	In line	G 1/2"	6.07.580
	MBDN-060-AANR	Double acting, one flanged port	60	350	Flanged	G 3/8"	6.07.590
	MBDN-060-ABNR	Double acting, two flanged ports	60	350	Flanged	G 3/8"	6.07.600
	MBDN-060-ABNR	Double acting, two flanged ports	60	350	Flanged	G 1/2"	6.07.610
	MBDN-060-ZDNA	Double acting, all flanged ports	60	350	Flanged	Ø10	6.07.620
	MBDN-100-ALDE	Double acting	100	350	In line	G 1/2"	6.07.630
	MBDN-100-ABNR	Double acting, two flanged ports	100	350	Flanged	Ø9	6.07.640
	MBDN-150-ZLDE	Double acting	150	350	In line	G 3/4"	6.07.650
	MBDN-150-ZLNP	Double acting	150	350	In line	G 3/4"	6.07.660
	MBDN-150-ZBNV	Double acting, two flanged ports	150	350	Flanged	G 3/4"	6.07.670
	MBDN-300-ZLNR	Double acting	150	350	In line	G 1"	6.07.680
	MBDP-060-ALNR	Double acting, relief compensated	60	350	In line	G 3/8"	6.08.690
	MBDP-060-ALNR	Double acting, relief compensated	60	350	In line	G 1/2"	6.08.700
MBDP-060-ZLDE	Double acting, relief compensated	60	350	In line	G 1/2"	6.08.710	
MBDP-150-ZLDE	Double acting, relief compensated	150	350	In line	G 3/4"	6.08.720	
MBDT-150-ZBNV	Double acting, two flanged ports, fully compens.	150	350	Flanged	G 3/4"	6.09.730	
	MBDN-500-ABNR	Double acting	500	420	Flanged	1 1/4" SAE 6000	6.10.740
	MBDN-500-ABNR	Double acting	500	420	Flanged	1 1/4" SAE 6000	6.10.750

OVERCENTRE VALVE

CBSN-030-PARH

POPPET TYPE

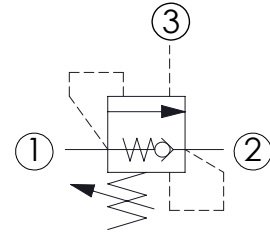
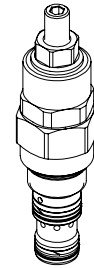
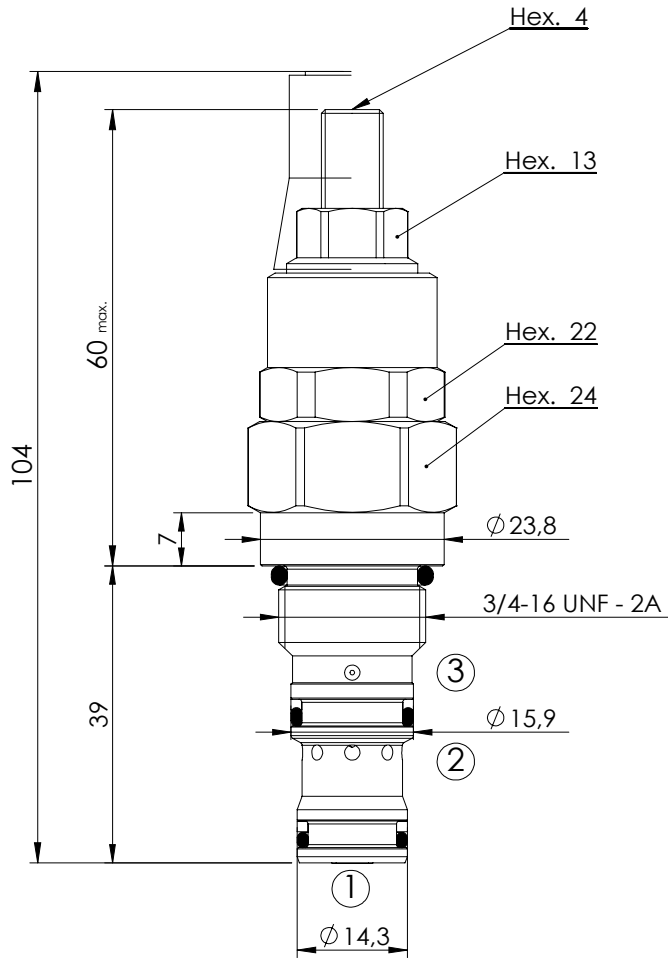

SPECIFICATIONS

Max. operating pressure:	350 bar
Rated flow:	30 l/min
Cavity:	SAE-08-3C
Weight:	0,18 kg

SEALING CAP

Ordering code:
AT000020

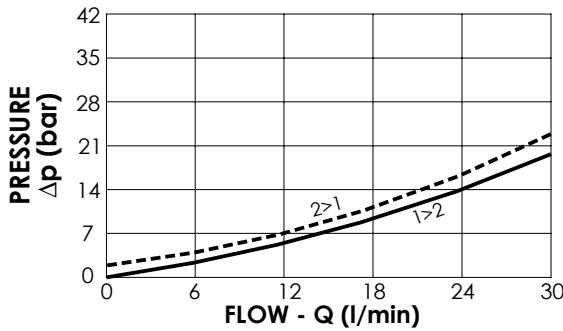
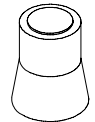

NOTES

Setting: at least 1.3 times the load induced pressure
Installation torque: **45 - 50 Nm**

ORDERING CODES

Quick code	Description	Pilot ratio	Standard setting (bar, Q=5 l/min)	Adjust. range (bar)	Pressure increase (bar/turn)
CB000007	CBSN-030-PARH-04-S08-N350	4:1	350	170 - 350	134
CB000023	CBSN-030-PARH-04-S08-N200	4:1	200	70-210	110

OVERCENTRE VALVE

CBSN-040-DCNH

DIFFERENTIAL AREA

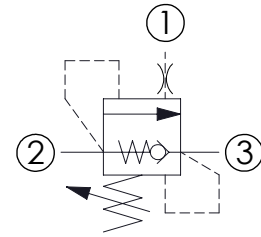
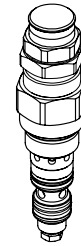
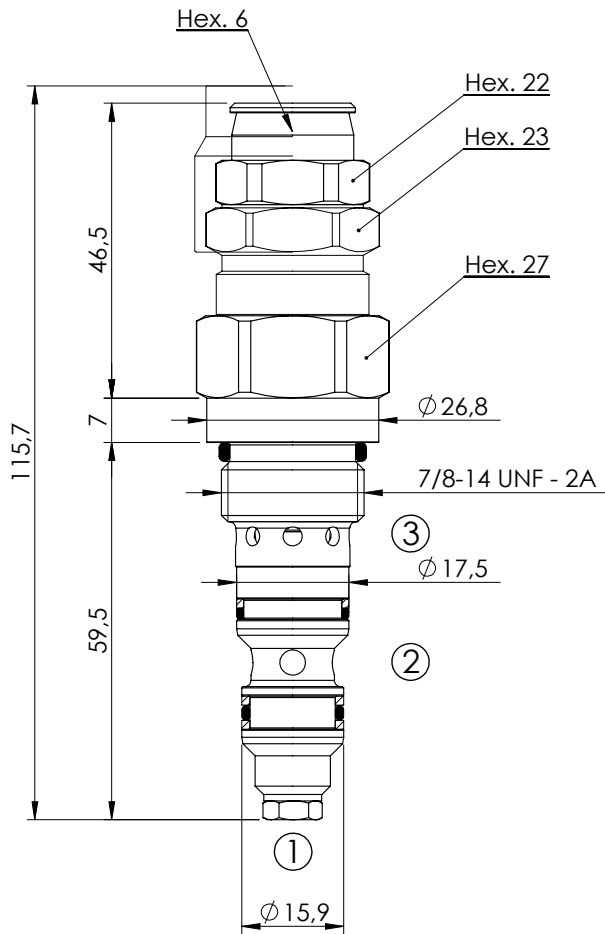

SPECIFICATIONS

Max. operating pressure:	350 bar
Rated flow:	40 l/min
Cavity:	VP000174
Weight:	0,26 kg

SEALING CAP

Ordering code:
PT000258

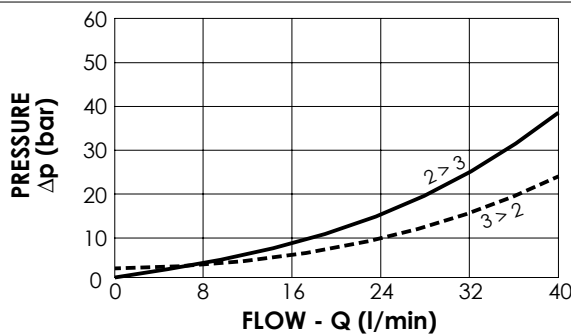
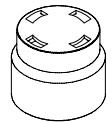

NOTES

Setting: at least 1.3 times the load induced pressure

Installation torque:

ORDERING CODES

Quick code	Description	Pilot ratio	Standard setting (bar, Q=5 l/min)	Adjust. range (bar)	Pressure increase (bar/turn)
CB000016	CBSN-040-DCNH-04-174-N350	4,1:1	350	100-350	145

OVERCENTRE VALVE

CBSN-060-DARH

POPPET TYPE
DIFFERENTIAL AREA

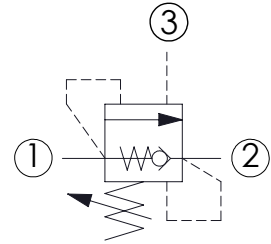
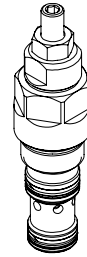
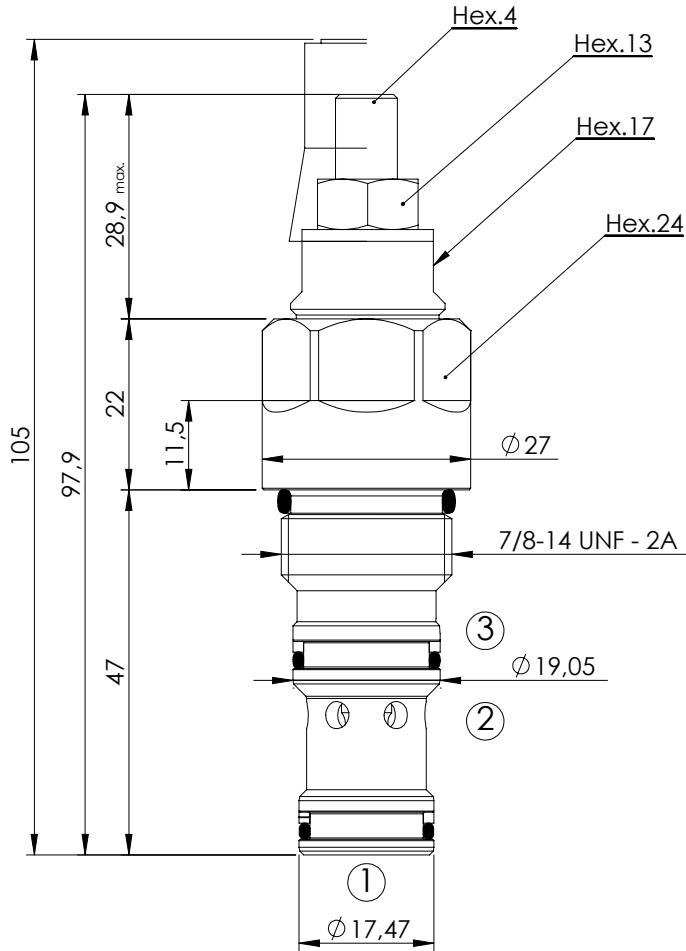

SPECIFICATIONS

Max. operating pressure:	350 bar
Rated flow:	60 l/min
Cavity:	
Weight:	0,2 kg

SEALING CAP

Ordering code:
AT000020

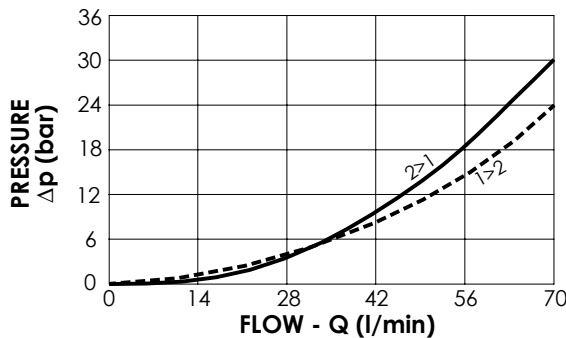
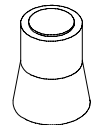

NOTES

Setting: at least 1.3 times the load induced pressure

Installation torque:

ORDERING CODES

Quick code	Description	Pilot ratio	Standard setting (bar, Q=5 l/min)	Adjust. range (bar)	Pressure increase (bar/turn)
CB000012	CBSN-060-DARH-03-S10-N350	3:1	350	140 - 350	197
CB000033	CBSN-060-DARH-03-S10-N200	3:1	200	70 - 210	147
CB000057	CBSN-060-DARH-08-S10-N350	8:1	350	140 - 350	93
CB000058	CBSN-060-DARH-08-S10-N200	8:1	200	70 - 210	55

OVERCENTRE VALVE

CBSN-060-DSRH

POPPET TYPE
DIFFERENTIAL AREA

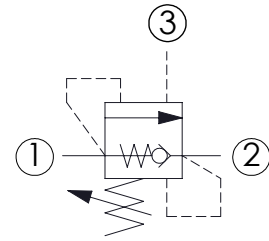
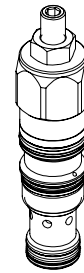
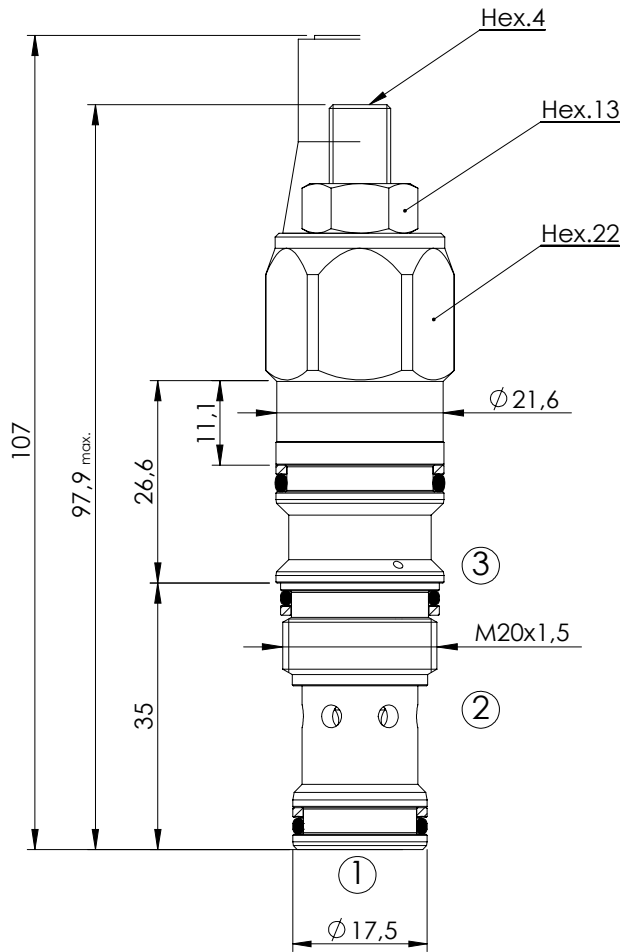

SPECIFICATIONS

Max. operating pressure:	350 bar
Rated flow:	60 l/min
Cavity:	VP000161 (SUN T-11A)
Weight:	0,18 kg

SEALING CAP

Ordering code:
AT000020

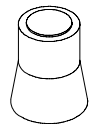

NOTES

- Setting: at least 1.3 times the load induced pressure
- Installation torque: 40 - 50 Nm
- Turn anticlockwise to increase the setting

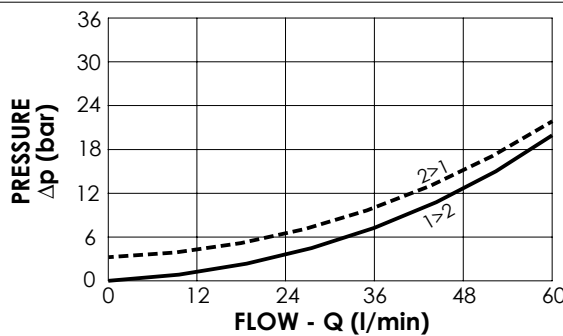

ORDERING CODES

Quick code	Description	Pilot ratio	Standard setting (bar, Q=5 l/min)	Adjust. range (bar)	Pressure increase (bar/turn)
CB000024	CBSN-060-DSRH-03-161-N350	3:1	350	140 - 350	197
CB000034	CBSN-060-DSRH-03-161-N200	3:1	200	70 - 210	147
CB000072	CBSN-060-DSRH-08-161-N350	8:1	350	140 - 350	93
CB000073	CBSN-060-DSRH-08-161-N200	8:1	200	70 - 210	55

OVERCENTRE VALVE

CBSN-060-DCNH

DIFFERENTIAL AREA

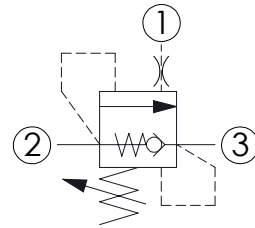
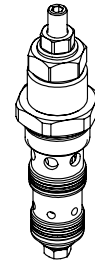
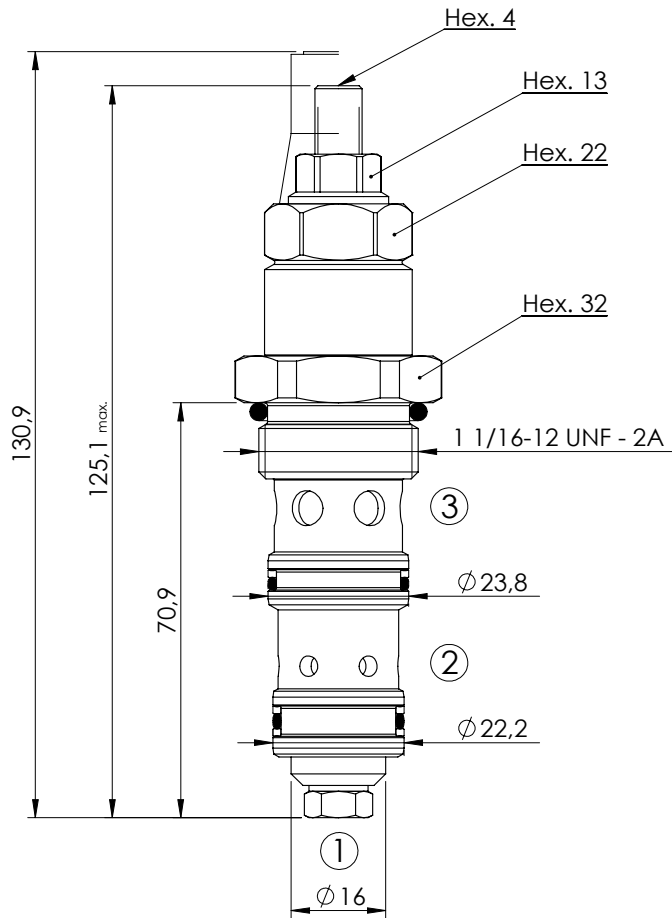

SPECIFICATIONS

Max. operating pressure:	350 bar
Rated flow:	60 l/min
Cavity:	VP000121
Weight:	0,31 kg

SEALING CAP

Ordering code:
AT000020

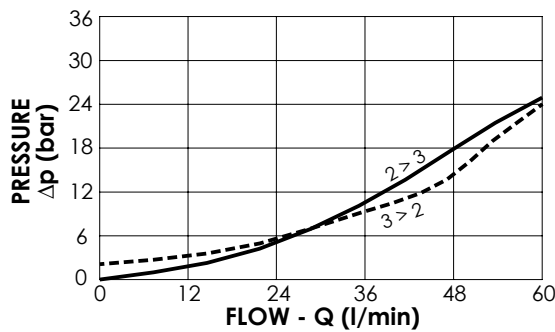
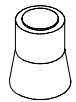

NOTES

Setting: at least 1.3 times the load induced pressure

Installation torque:

ORDERING CODES

Quick code	Description	Pilot ratio	Standard setting (bar, Q=5 l/min)	Adjust. range (bar)	Pressure increase (bar/turn)
CB000002	CBSN-060-DCNH-04-121-N350	4,2:1	350	100-350	139
CB000003	CBSN-060-DCNH-04-121-N200	4,2:1	200	60-210	62

OVERCENTRE VALVE

CBSN-100-DCNH

DIFFERENTIAL AREA

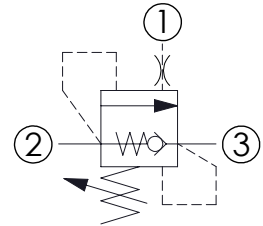
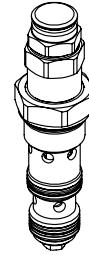
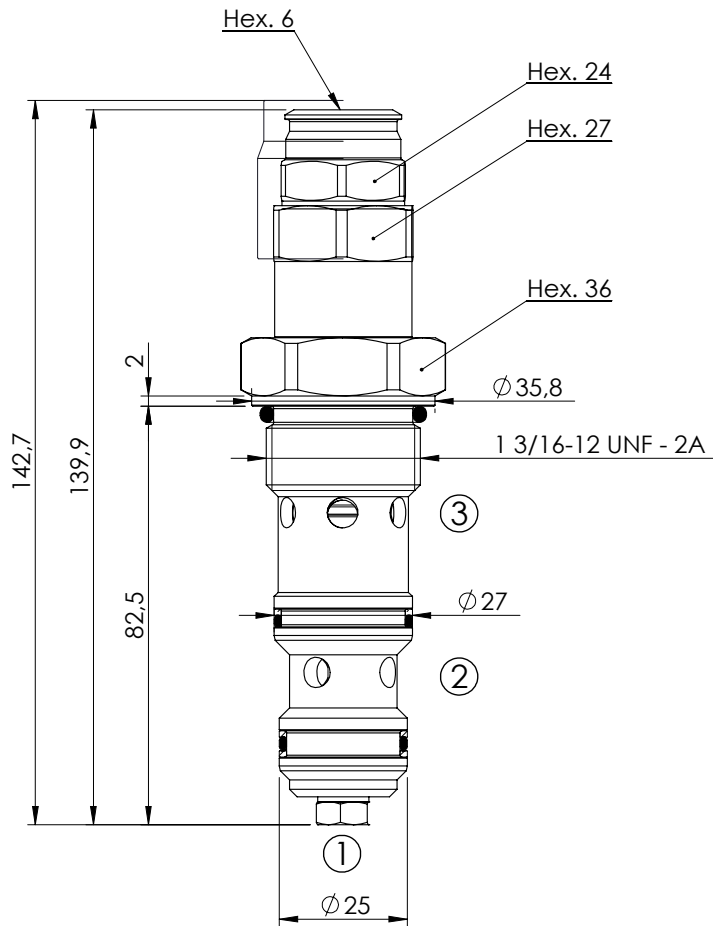

SPECIFICATIONS

Max. operating pressure:	350 bar
Rated flow:	100 l/min
Cavity:	VP000120
Weight:	0,52 kg

SEALING CAP

Ordering code:
PT000243

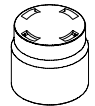

NOTES

Setting: at least 1.3 times the load induced pressure

Installation torque:

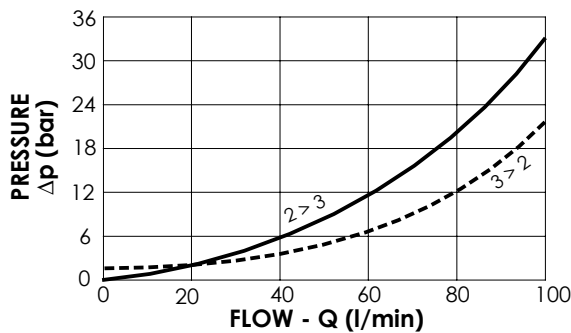

ORDERING CODES

Quick code	Description	Pilot ratio	Standard setting (bar, Q=5 l/min)	Adjust. range (bar)	Pressure increase (bar/turn)
CB000015	CBSN-100-DCNH-04-120-N350	3,8:1	350	100-350	118
CB000113	CBSN-100-DCNH-04-120-N200	3,8:1	200	60-210	68
CB000094	CBSN-100-DCNH-08-120-N350	8:1	350	100-350	132
CB000114	CBSN-100-DCNH-08-120-N200	8:1	200	60-210	58

OVERCENTRE VALVE

CBSN-120-DSRH

POPPET TYPE
DIFFERENTIAL AREA

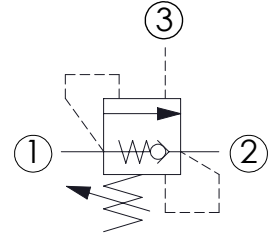
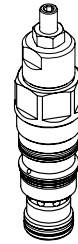
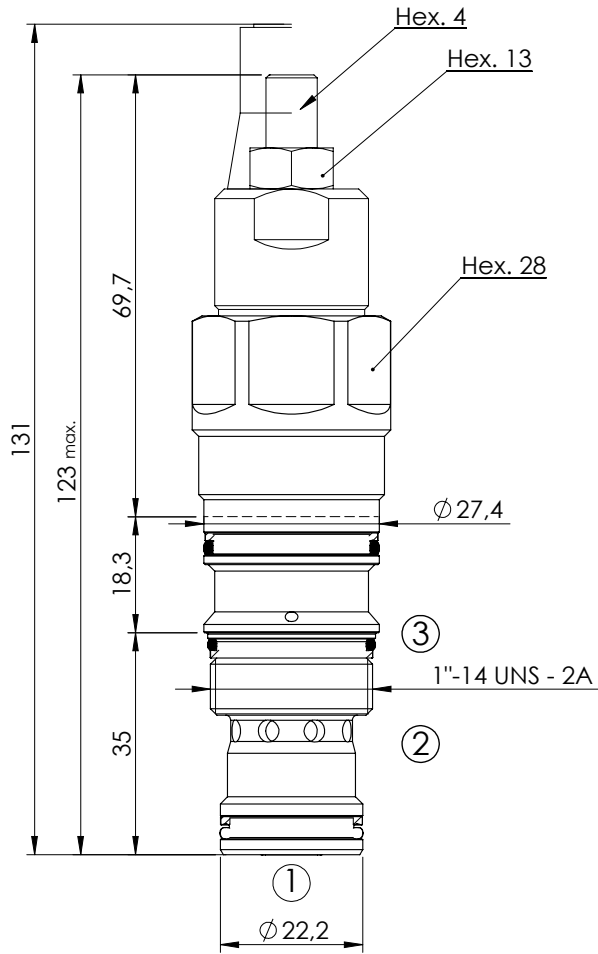

SPECIFICATIONS

Max. operating pressure:	350 bar
Rated flow:	120 l/min
Cavity:	VP000165 (SUN T-2A)
Weight:	0,36 kg

SEALING CAP

Ordering code:
AT000020

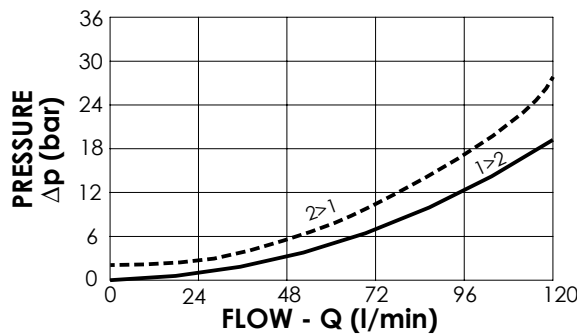
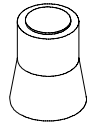

NOTES

Setting: at least 1.3 times the load induced pressure

Installation torque:

ORDERING CODES

Quick code	Description	Pilot ratio	Standard setting (bar, Q=5 l/min)	Adjust. range (bar)	Pressure increase (bar/turn)
CB000029	CBSN-120-DSRH-04-165-N350	4:1	350	140 - 350	174
CB000035	CBSN-120-DSRH-04-165-N200	4:1	200	70 - 210	58
CB000085	CBSN-120-DSRH-08-165-N350	8:1	350	140 - 350	72
CB000093	CBSN-120-DSRH-08-165-N200	8:1	200	70 - 210	44

OVERCENTRE VALVE

CBSN-120-DAGH

DIFFERENTIAL AREA
POPPET TYPE

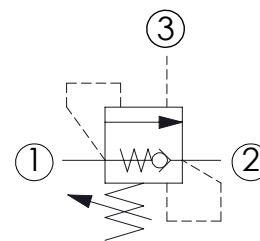
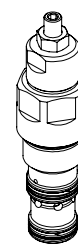
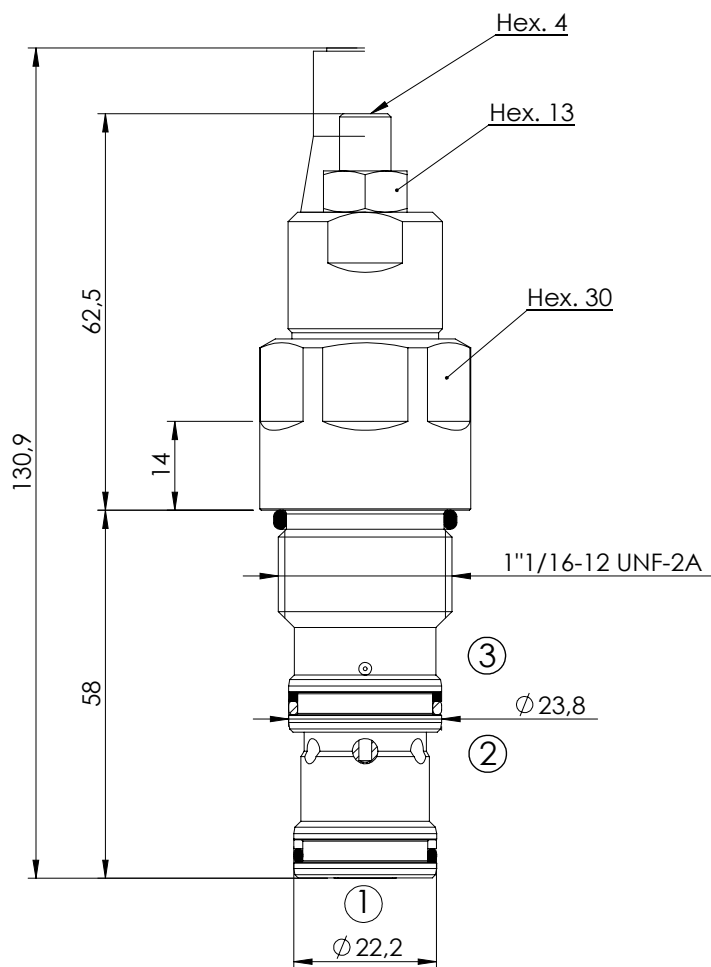

SPECIFICATIONS

Max. operating pressure:	350 bar
Rated flow:	120 l/min
Cavity:	SAE-12-3C
Weight:	0,38 kg

SEALING CAP

Ordering code:
AT000020

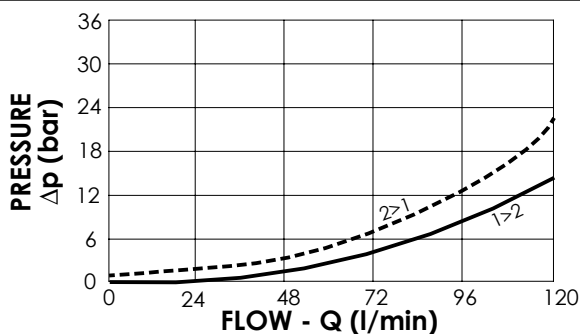
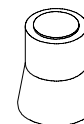

NOTES

- Setting: at least 1.3 times the load induced pressure
- Installation torque: 80 - 95 Nm
- Seal kit: RA700088
- Turn clockwise to increase the setting

ORDERING CODES

Quick code	Description	Pilot ratio	Standard setting (bar, Q=5 l/min)	Adjust. range (bar)	Pressure increase (bar/turn)
CB000045	CBSN-120-DARH-04-S12-N350	4:1	350	140 - 350	174
		4:1	200	70 - 210	58
		8:1	350	140 - 350	72
		8:1	200	70 - 210	44

OVERCENTRE VALVE

CBSN-150-DCNH

DIFFERENTIAL AREA

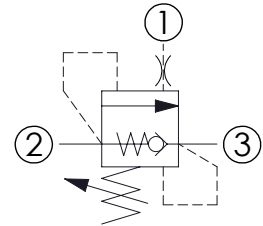
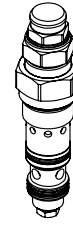
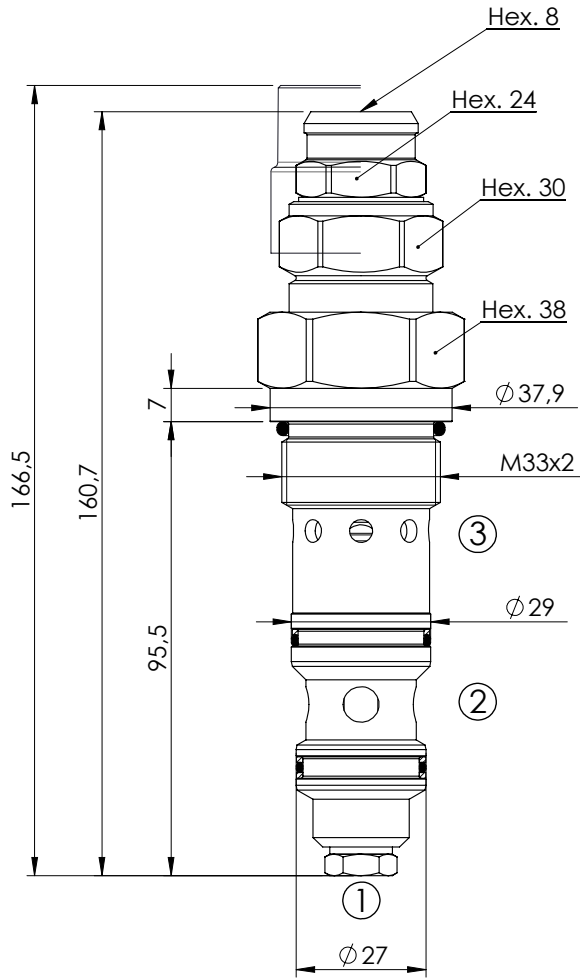

SPECIFICATIONS

Max. operating pressure:	350 bar
Rated flow:	150 l/min
Cavity:	VP000128
Weight:	0,7 kg

SEALING CAP

Ordering code:
ST000012

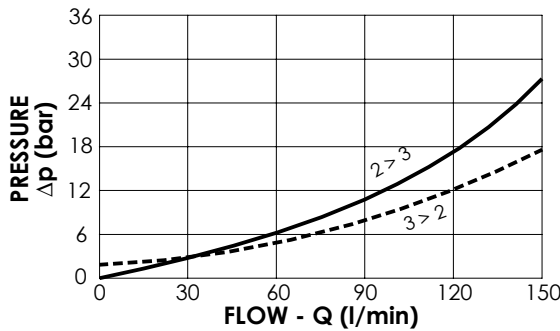
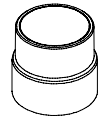

NOTES

Setting: at least 1.3 times the load induced pressure

Installation torque:

ORDERING CODES

Quick code	Description	Pilot ratio	Standard setting (bar, Q=5 l/min)	Adjust. range (bar)	Pressure increase (bar/turn)
CB000004	CBSN-150-DCNH-04-128-N350	4:1	350	100-350	103
CB000043	CBSN-150-DCNH-08-128-N350	8:1	350	100-350	82

OVERCENTRE VALVE

CBSN-240-DSGH

POPPET TYPE
DIFFERENTIAL AREA

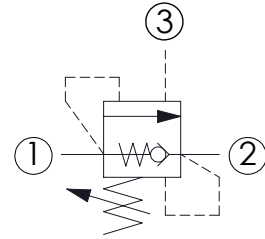
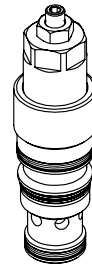
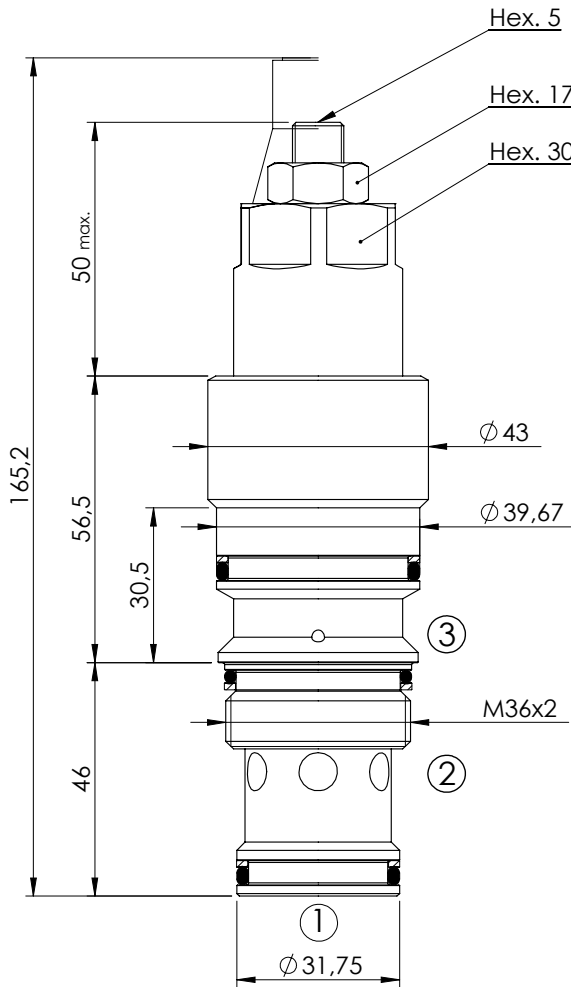

SPECIFICATIONS

Max. operating pressure:	350 bar
Rated flow:	240 l/min
Cavity:	VP000166 (SUN T-17A)
Weight:	0,73 kg

SEALING CAP

Ordering code:
AT000022

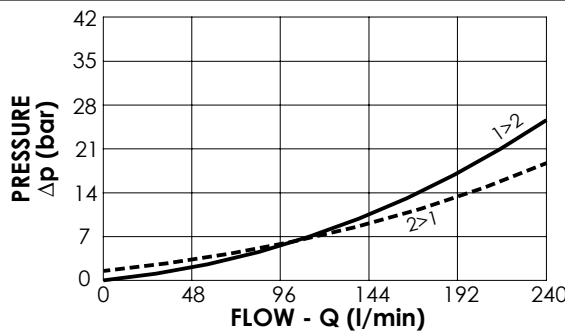
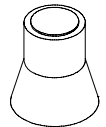

NOTES

Setting: at least 1.3 times the load induced pressure

Installation torque:

ORDERING CODES

Quick code	Description	Pilot ratio	Standard setting (bar, Q=5 l/min)	Adjust. range (bar)	Pressure increase (bar/turn)
CB000028	CBSN-240-DSGH-04-166-N350	4:1	350	140-350	114

OVERCENTRE VALVE

CBSN-300-DCNH

DIFFERENTIAL AREA

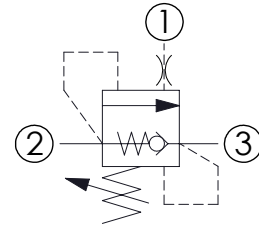
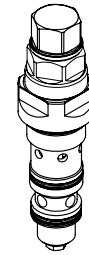
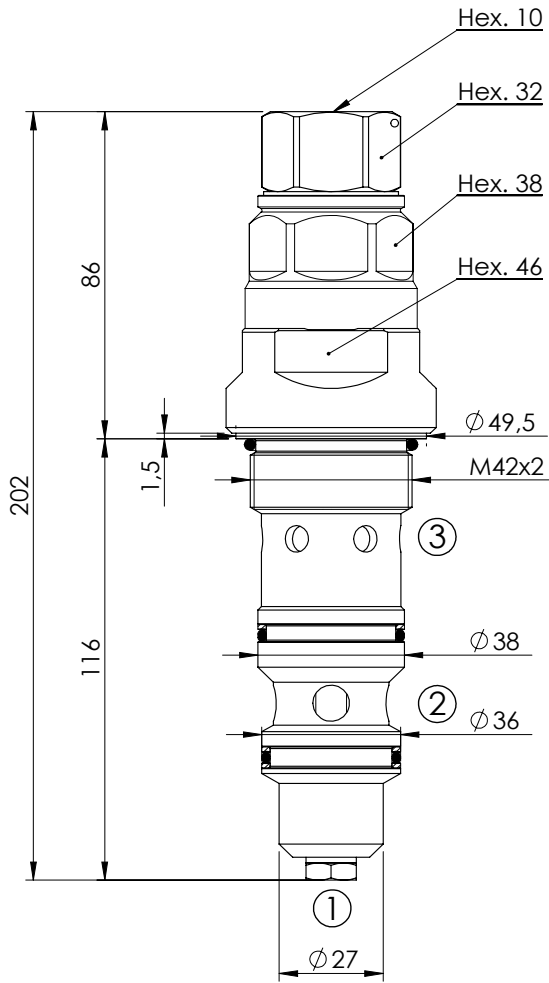

SPECIFICATIONS

Max. operating pressure:	350 bar
Rated flow:	300 l/min
Cavity:	VP000127
Weight:	1,5 kg

SEALING CAP

Ordering code:

NOTES

Setting: at least 1.3 times the load induced pressure

Installation torque:

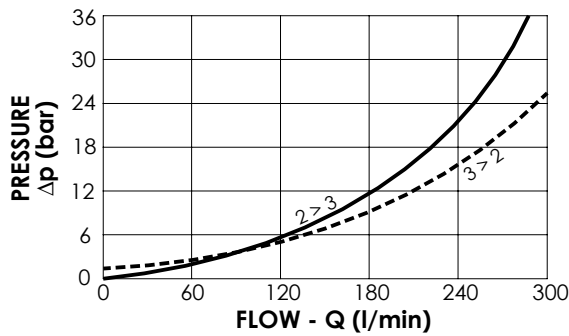

ORDERING CODES

Quick code	Description	Pilot ratio	Standard setting (bar, Q=5 l/min)	Adjust. range (bar)	Pressure increase (bar/turn)
CB000005	CBSN-300-DCNH-04-127-N350	4:1	350	100-350	75

OVERCENTRE VALVE

CBSN-320-DARH

DIFFERENTIAL AREA
POPPET TYPE

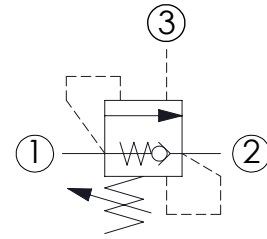
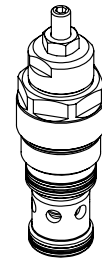
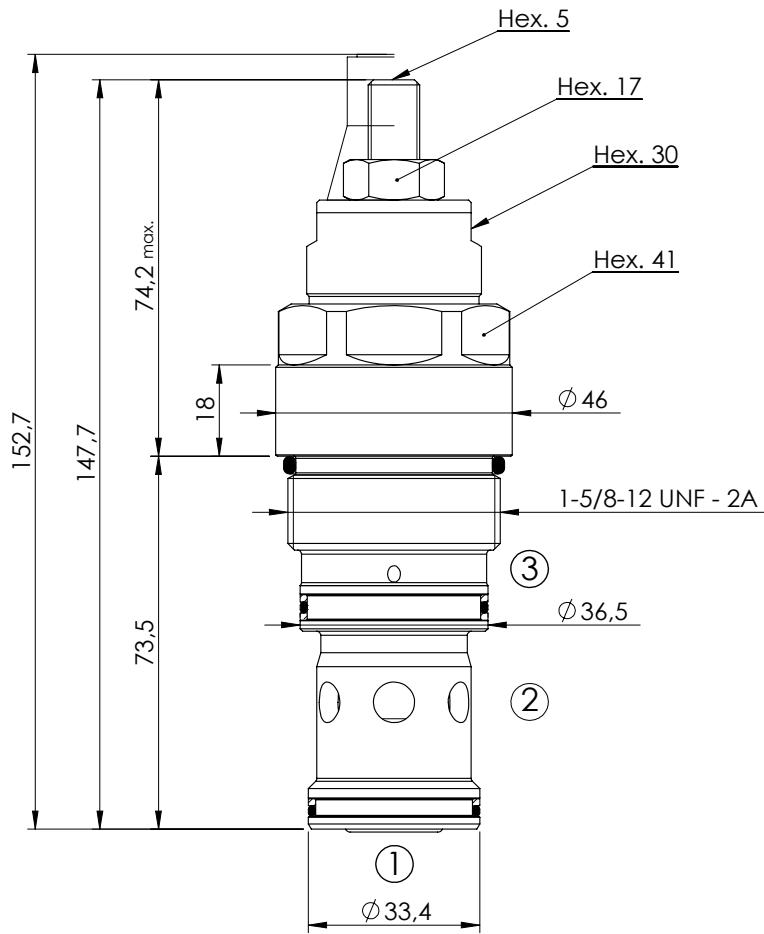

SPECIFICATIONS

Max. operating pressure:	350 bar
Rated flow:	320 l/min
Cavity:	SAE-20-3C
Weight:	0,87 kg

SEALING CAP

Ordering code:
AT000021

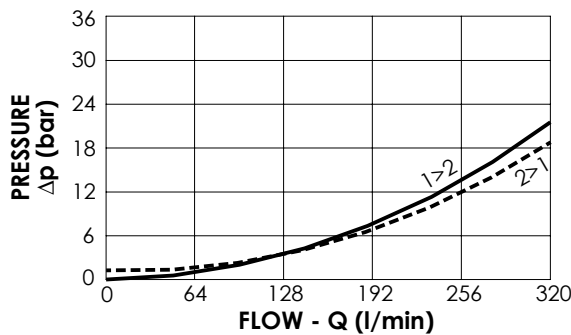
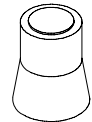

NOTES

Setting: at least 1.3 times the load induced pressure

Installation torque:

ORDERING CODES

Quick code	Description	Pilot ratio	Standard setting (bar, Q=5 l/min)	Adjust. range (bar)	Pressure increase (bar/turn)
CB000025	CBSN-320-DARH-04-S20-N350	4:1	350	140 - 350	120
CB000026	CBSN-320-DARH-04-S20-N200	4:1	200	70-210	47
CB000027	CBSN-320-DARH-08-S20-N350	8:1	350	140 - 350	87

OVERCENTRE VALVE

CBST-030-PARH

POPPET TYPE
FULLY COMPENSATED

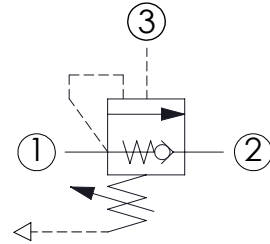
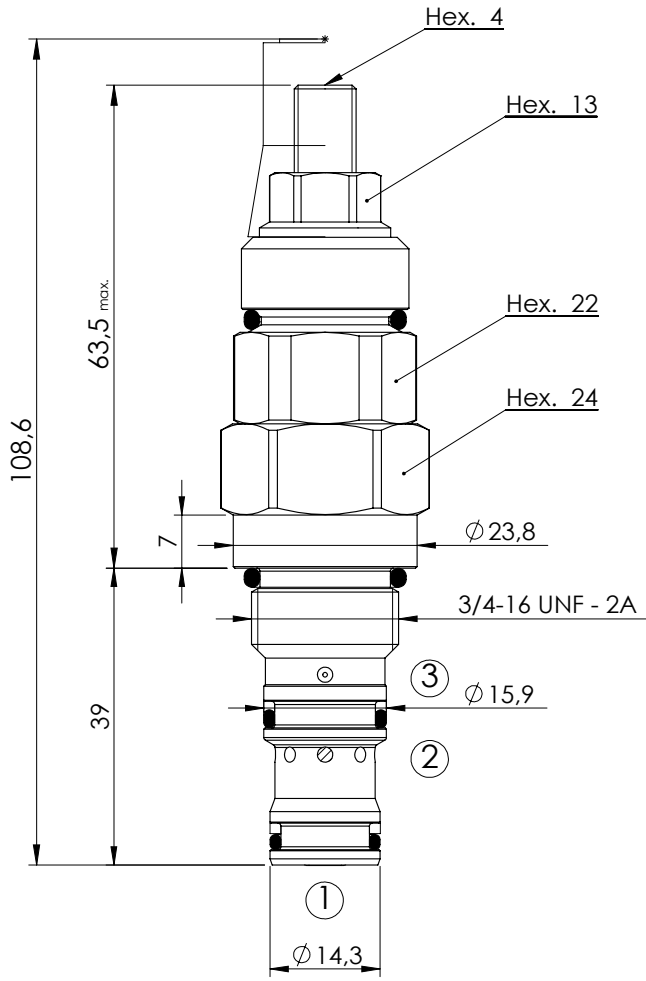

SPECIFICATIONS

Max. operating pressure:	350 bar
Rated flow:	30 l/min
Cavity:	SAE-08-3C
Weight:	0,19 kg

SEALING CAP

Ordering code:
AT000020

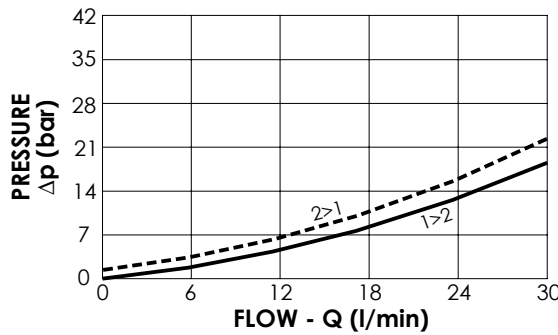
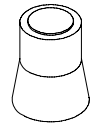

NOTES

Setting: at least 1.3 times the load induced pressure

Installation torque:

ORDERING CODES

Quick code	Description	Pilot ratio	Standard setting (bar, Q=5 l/min)	Adjust. range (bar)	Pressure increase (bar/turn)
CB000011	CBST-030-PARH-04-S08-N350	4:1	350	170 - 350	134
CB000070	CBST-030-PARH-04-S08-N200	4:1	200	70-210	95

OVERCENTRE VALVE

CBST-040-DCNH

FULLY COMPENSATED

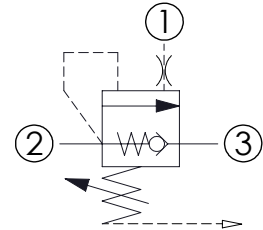
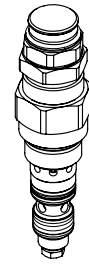
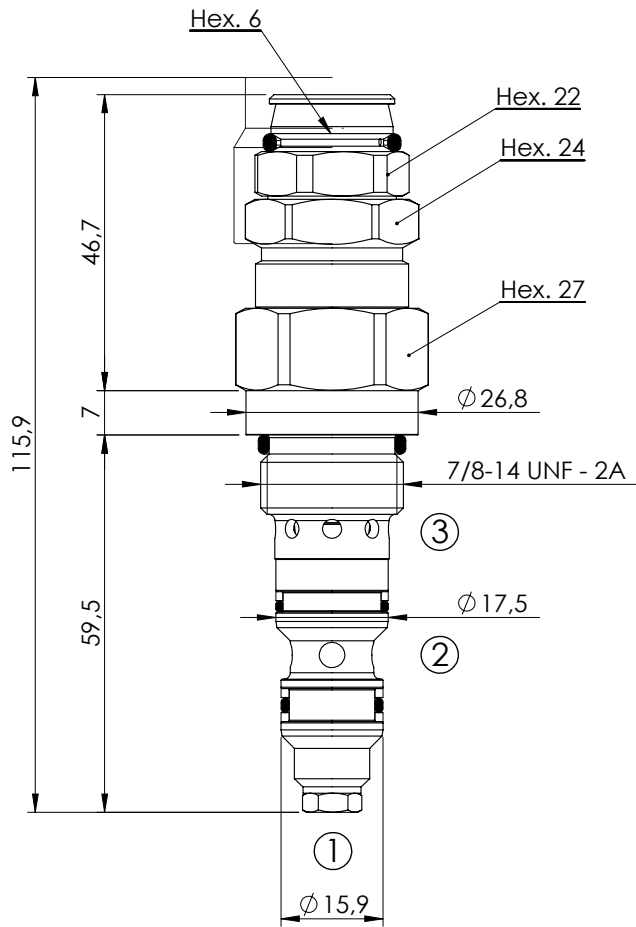

SPECIFICATIONS

Max. operating pressure:	350 bar
Rated flow:	40 l/min
Cavity:	VP000174
Weight:	0,26 kg

SEALING CAP

Ordering code:
PT000258

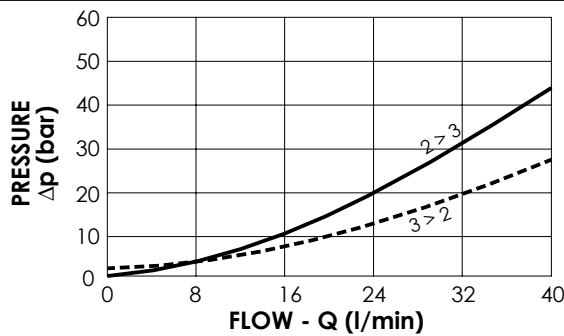
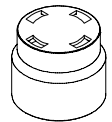

NOTES

Setting: at least 1.3 times the load induced pressure

Installation torque:

ORDERING CODES

Quick code	Description	Pilot ratio	Standard setting (bar, Q=5 l/min)	Adjust. range (bar)	Pressure increase (bar/turn)
CB000008	CBST-040-DCNH-04-174-N350	4,1:1	350	100-350	144
CB000051	CBST-040-DCNH-04-174-N200	4,1:1	200	60-210	66

OVERCENTRE VALVE

CBST-100-DCNH

FULLY COMPENSATED

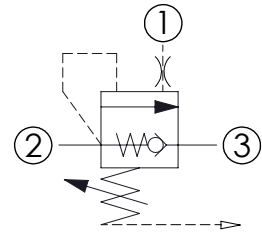
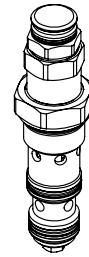
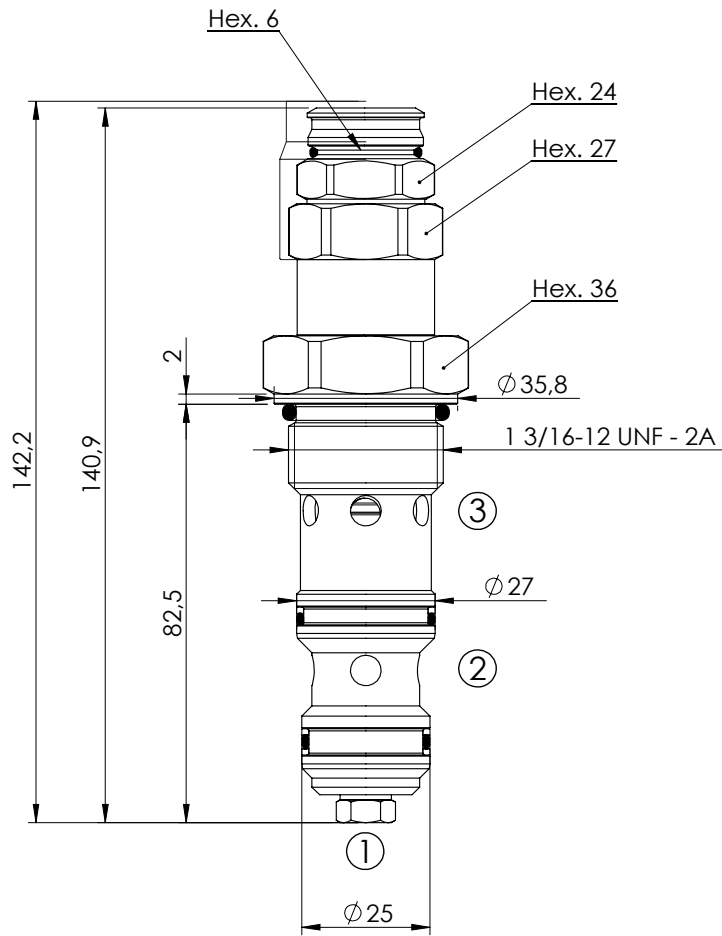

SPECIFICATIONS

Max. operating pressure:	350 bar
Rated flow:	100 l/min
Cavity:	VP000120
Weight:	0,51 kg

SEALING CAP

Ordering code:
PT000243

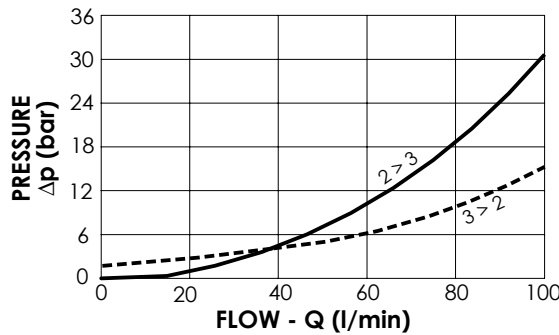
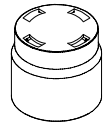

NOTES

Setting: at least 1.3 times the load induced pressure

Installation torque:

ORDERING CODES

Quick code	Description	Pilot ratio	Standard setting (bar, Q=5 l/min)	Adjust. range (bar)	Pressure increase (bar/turn)
CB000001	CBST-100-DCNH-04-120-N350	3,8:1	350	100-350	118
CB000102	CBST-100-DCNH-08-120-N350	8:1	350	100-350	205

OVERCENTRE VALVE

CBST-150-DCNH

FULLY COMPENSATED

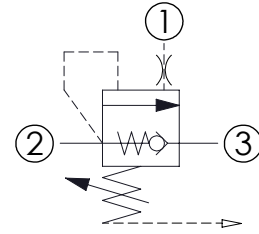
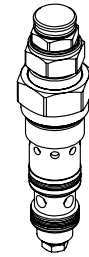
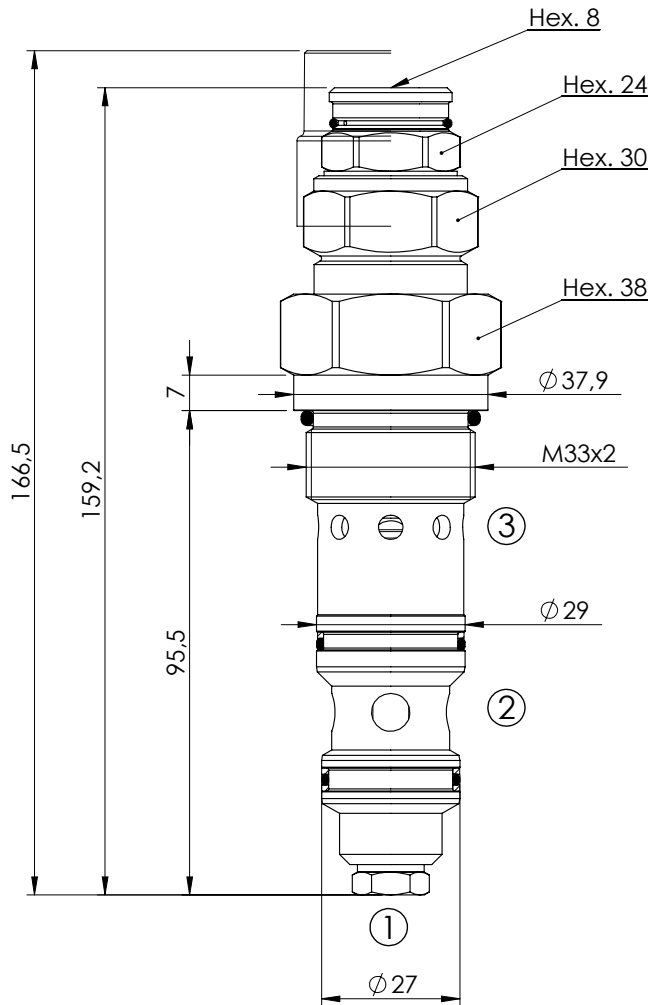

SPECIFICATIONS

Max. operating pressure:	350 bar
Rated flow:	150 l/min
Cavity:	VP000128
Weight:	0,7 kg

SEALING CAP

Ordering code:
ST000012

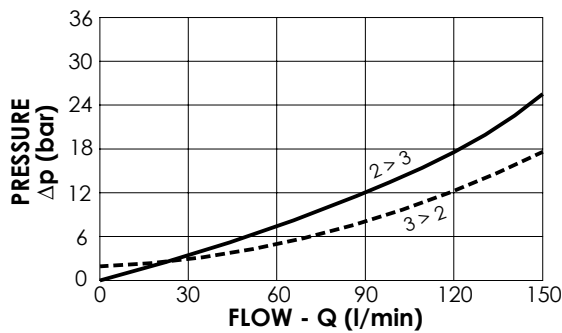

NOTES

Setting: at least 1.3 times the load induced pressure

Installation torque:

ORDERING CODES

Quick code	Description	Pilot ratio	Standard setting (bar, Q=5 l/min)	Adjust. range (bar)	Pressure increase (bar/turn)
CB000014	CBST-150-DCNH-04-128-N350	4:1	350	100-350	103
CB000022	CBST-150-DCNH-08-128-N350	8:1	350	100-350	100

OVERCENTRE VALVE

CBST-300-DCNH

FULLY COMPENSATED

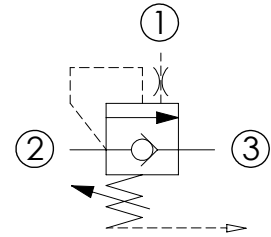
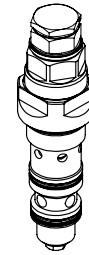
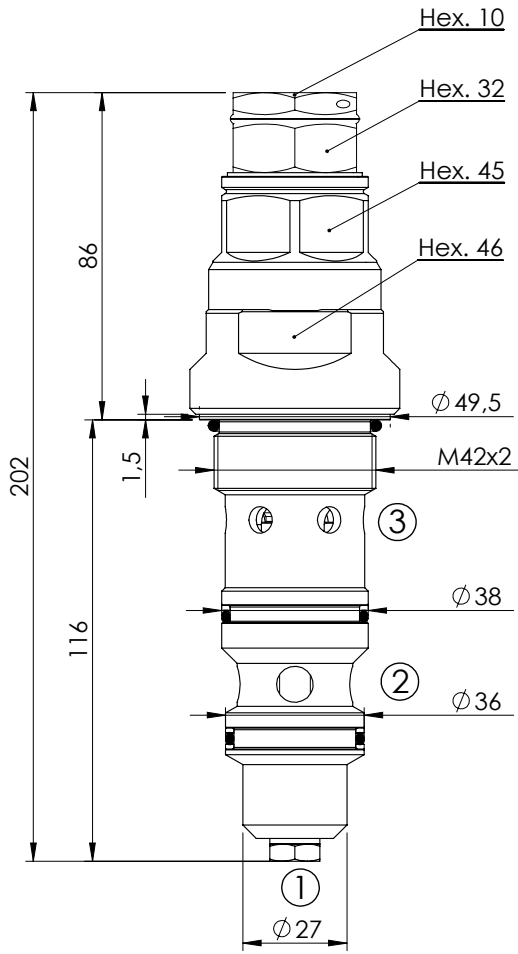

SPECIFICATIONS

Max. operating pressure:	350 bar
Rated flow:	300 l/min
Cavity:	VP000127
Weight:	1,49 kg

SEALING CAP

Ordering code:

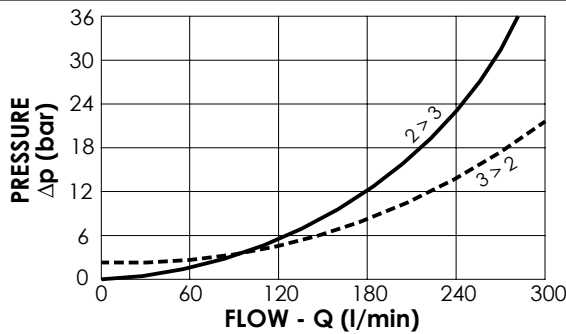

NOTES

Setting: at least 1.3 times the load induced pressure

Installation torque: 246 - 272 Nm

ORDERING CODES

Quick code	Description	Pilot ratio	Standard setting (bar, Q=5 l/min)	Adjust. range (bar)	Pressure increase (bar/turn)
CB000017	CBST-300-DCNH-06-127-N350	6:1	350	100-350	62
CB000013	CBST-300-DCNH-04-127-N350	4:1	350	100-350	75

OVERCENTRE VALVE

MBSN-040-ALNP

SINGLE ACTING

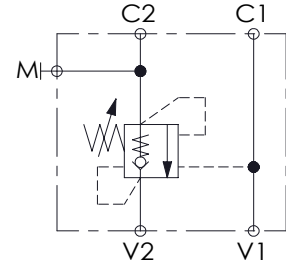
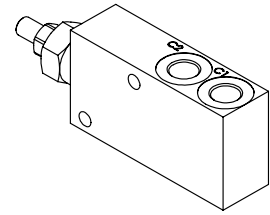
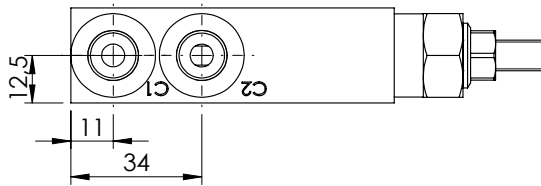
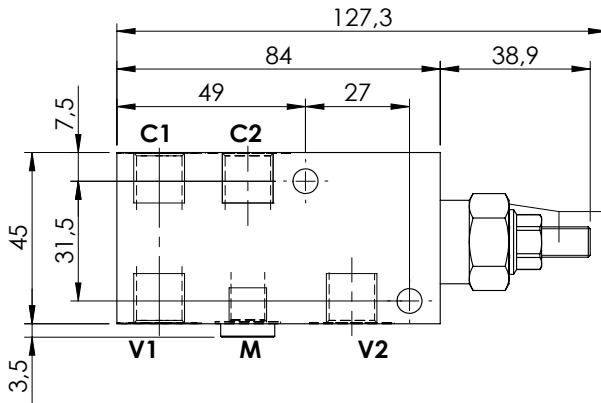
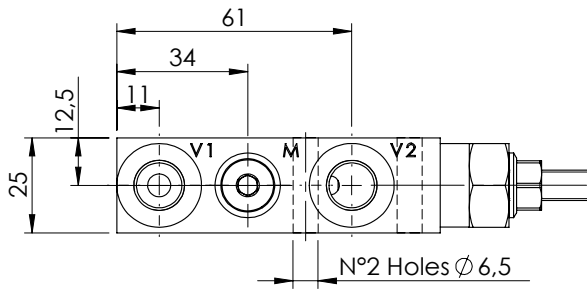

SPECIFICATIONS

Max. operating pressure:	350 bar
Rated flow:	40 l/min
Manifold:	Steel
Weight:	0,71 kg

SEALING CAP

Ordering code:
AT000020

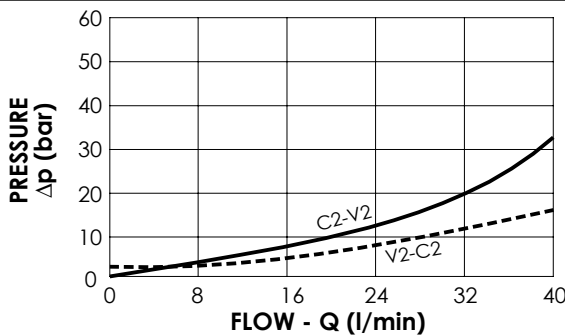
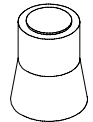

NOTES

Setting: at least 1.3 times the load induced pressure

ORDERING CODES

Quick code	Description	Pilot ratio	Main ports size	Standard setting (bar, Q=5 l/min)	Adjust. range (bar)	Pressure increase (bar/turn)
MB000074	MBSN-040-ALNP-04-G14-N350	4,1:1	V1,V2: G1/4" M: G1/8" C1,C2: G1/4"	350	100-350	184
MB000604	MBSN-040-ALNP-04-G14-N200	4,1:1	V1,V2: G1/4" M: G1/8" C1,C2: G1/4"	200	60-210	83

OVERCENTRE VALVE

MBSN-040-ZLNA

SINGLE ACTING
IN LINE PORTS

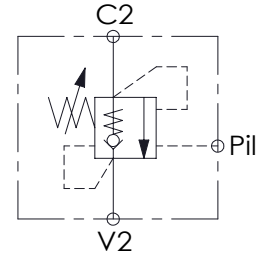
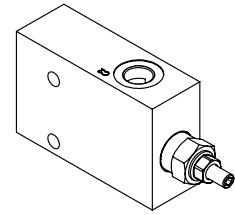
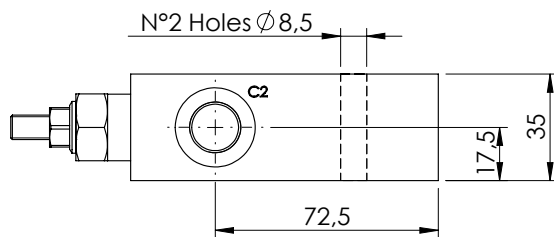
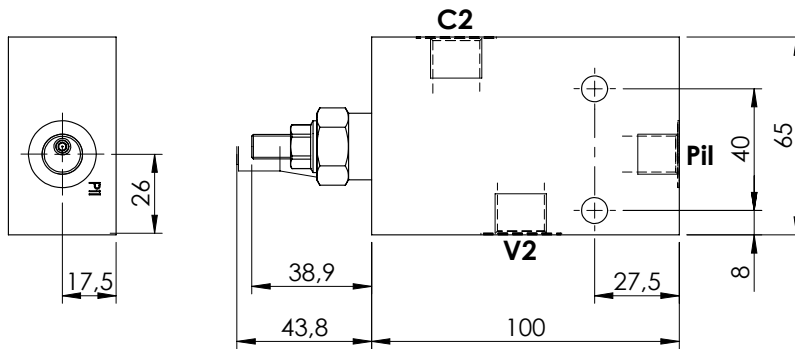
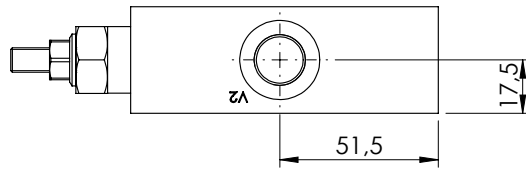

SPECIFICATIONS

Max. operating pressure:	350 bar
Rated flow:	40 l/min
Manifold:	Aluminium
Weight:	0,64 kg

SEALING CAP

Ordering code:
AT000020

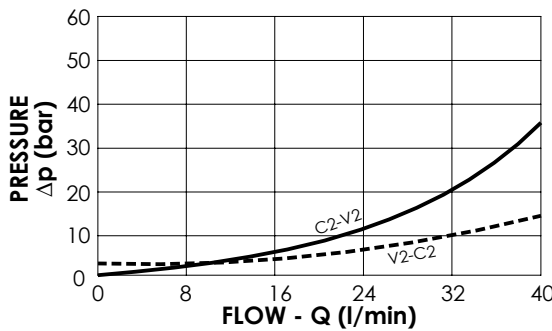
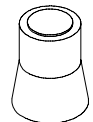

NOTES

Setting: at least 1.3 times the load induced pressure

ORDERING CODES

Quick code	Description	Pilot ratio	Main ports size	Standard setting (bar, Q=5 l/min)	Adjust. range (bar)	Pressure increase (bar/turn)
MB000564	MBSN-040-ZLNA-04-G38-N350	4,1:1	C2,V2: G 3/8" Pil: G 1/4"	350	100-350	184
MB000565	MBSN-040-ZLNA-04-G38-N200	4,1:1	C2,V2: G 3/8" Pil: G 1/4"	200	60-210	83
MB000566	MBSN-040-ZLNA-07-G38-N350	7,5:1	C2,V2: G 3/8" Pil: G 1/4"	350	100-350	138
MB000567	MBSN-040-ZLNA-07-G38-N200	7,5:1	C2,V2: G 3/8" Pil: G 1/4"	200	60-210	83

OVERCENTRE VALVE

MBSN-040-AANP

SINGLE ACTING
ONE FLANGED PORT



O-Ring 9,93 x 2,62 - N70

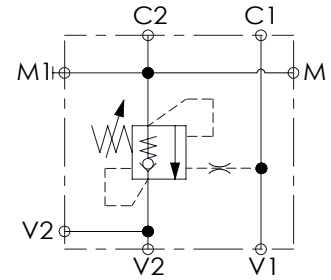
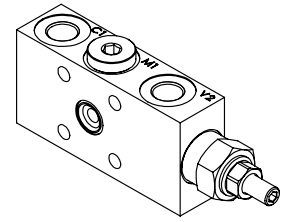
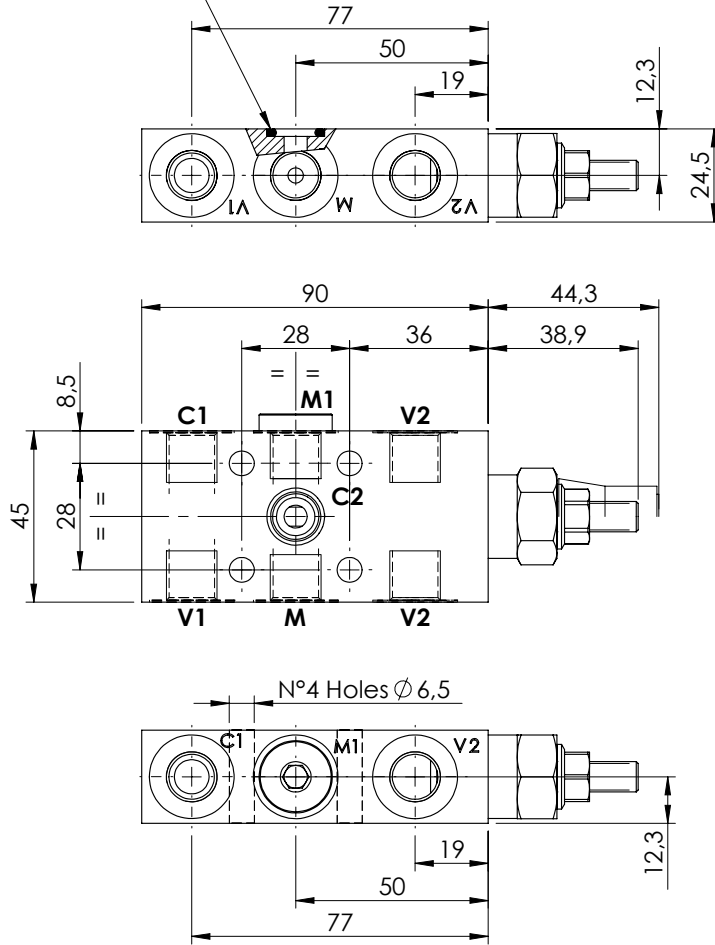

SPECIFICATIONS

Max. operating pressure:	350 bar
Rated flow:	40 l/min
Manifold:	Steel
Weight:	0,71 kg

SEALING CAP

Ordering code:
AT000020

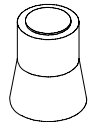

NOTES

Setting: at least 1.3 times the load induced pressure

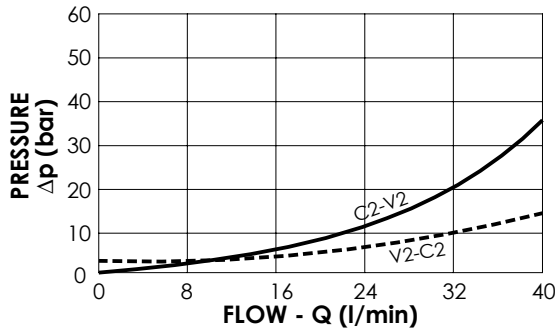

ORDERING CODES

Quick code	Description	Pilot ratio	Main ports size	Standard setting (bar, Q=5 l/min)	Adjust. range (bar)	Pressure increase (bar/turn)
MB000105	MBSN-040-AANP-04-G14-N350	4,1:1	V1, V2, M, M1: G1/4" C1: G1/4" C2: Ø6	350	100-350	184

OVERCENTRE VALVE

MBSN-040-ZDNA

SINGLE ACTING
ALL FLANGED PORTS

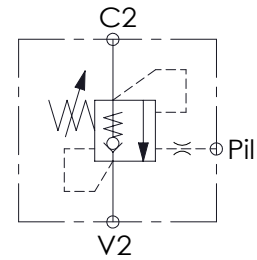
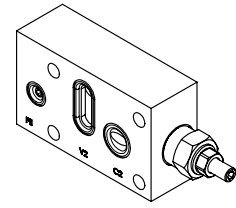
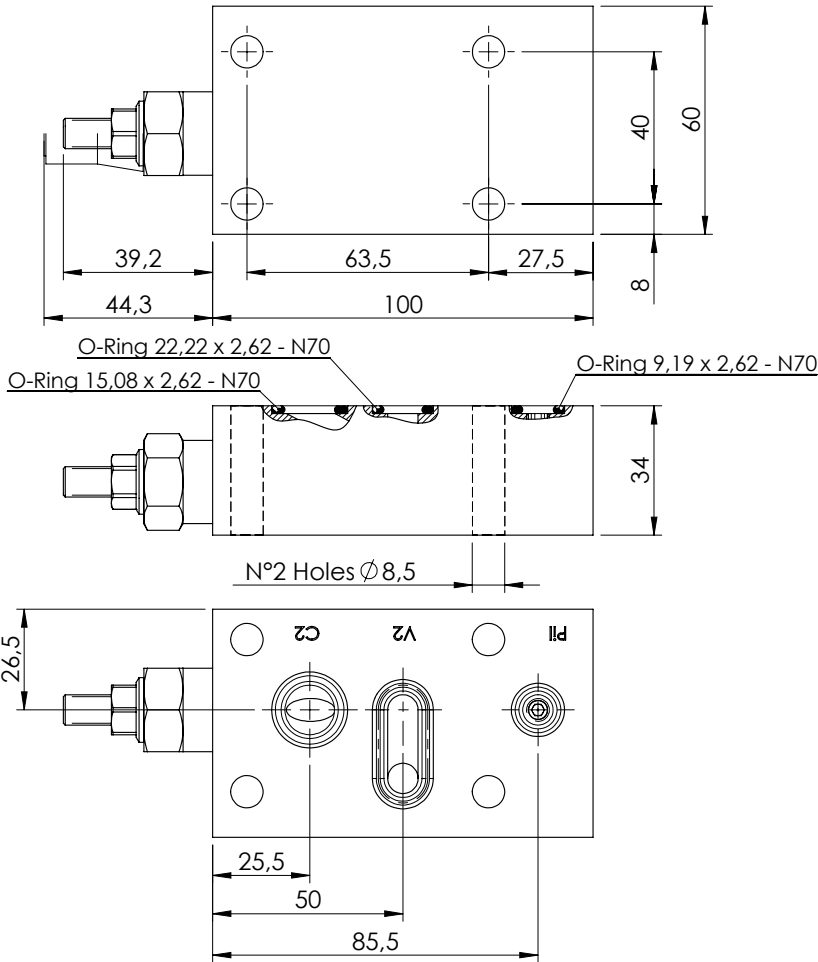

SPECIFICATIONS

Max. operating pressure:	350 bar
Rated flow:	40 l/min
Weight:	0.9 kg

SEALING CAP

Ordering code:
AT000020

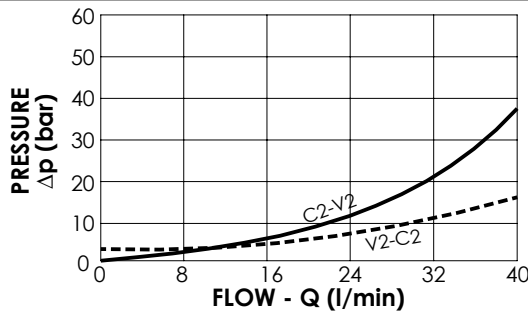
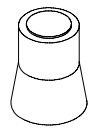

NOTES

Setting: at least 1.3 times the load induced pressure

ORDERING CODES

Quick code	Description	Pilot ratio	Manifold material	Main ports size	Standard setting (bar, Q=5 l/min)	Adjust. range (bar)	Pressure increase (bar/turn)
MB000525	MBSN-040-ZDNA-04-PTF-N350	4,1:1	Aluminium	C2,V2: ϕ 8 Pil: ϕ 5	350	100-350	184
MB000526	MBSN-040-ZDNA-04-PTF-N200	4,1:1	Aluminium	C2,V2: ϕ 8 Pil: ϕ 5	200	60-210	83

OVERCENTRE VALVE

MBSN-040-APNR

SINGLE ACTING
BANJO MOUNTING

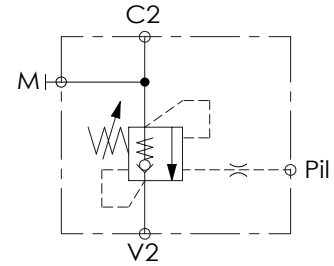
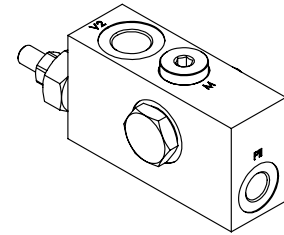
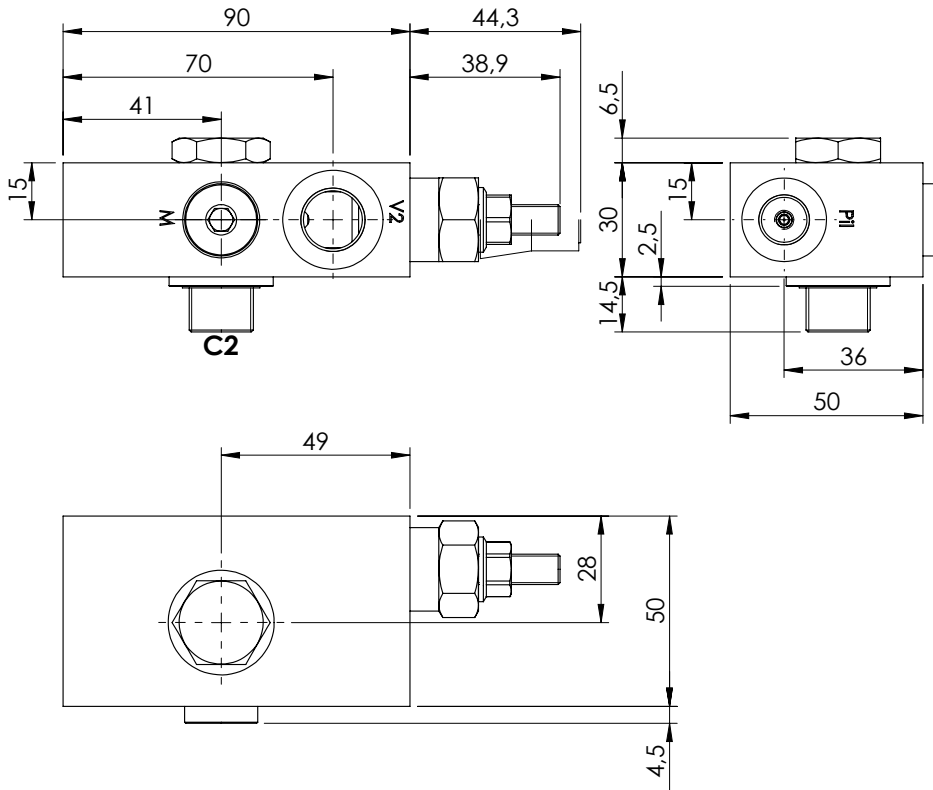

SPECIFICATIONS

Max. operating pressure:	350 bar
Rated flow:	40 l/min
Manifold:	Steel
Weight:	1,07 kg

SEALING CAP

Ordering code:
AT000020

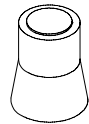

NOTES

Setting: at least 1.3 times the load induced pressure

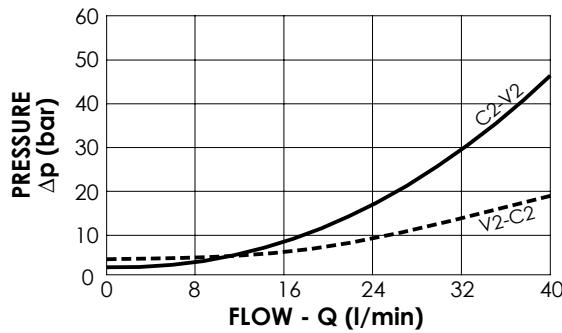

ORDERING CODES

Quick code	Description	Pilot ratio	Main ports size	Standard setting (bar, Q=5 l/min)	Adjust. range (bar)	Pressure increase (bar/turn)
MB000469	MBSN-040-APNR-04-G38-N350	4,1:1	C2,V2: G3/8" M,Pil: G1/4"	350	100-350	184
MB000578	MBSN-040-APNR-04-G38-N200	4,1:1	C2,V2: G3/8" M,Pil: G1/4"	200	60-210	83
MB000840	MBSN-040-APNR-07-G38-N350	7,5:1	C2,V2: G3/8" M,Pil: G1/4"	350	100-350	138

OVERCENTRE VALVE

MBSN-060-ALNR

SINGLE ACTING

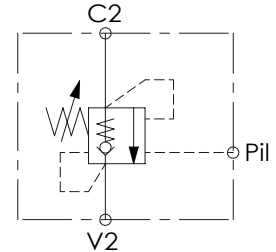
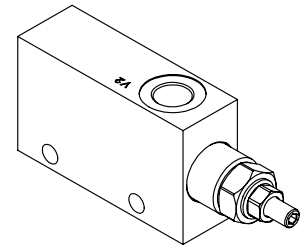
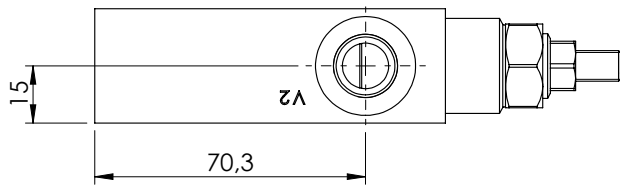
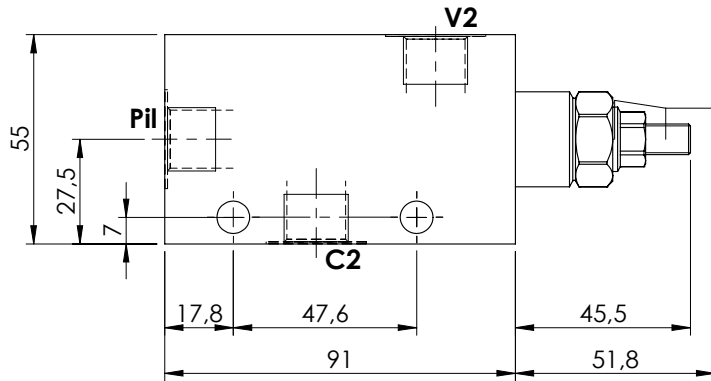
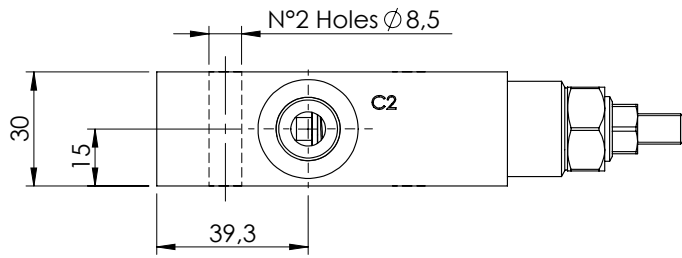

SPECIFICATIONS

Max. operating pressure:	350 bar
Rated flow:	60 l/min
Manifold:	Steel
Weight:	1,11 kg

SEALING CAP

Ordering code:
AT000020

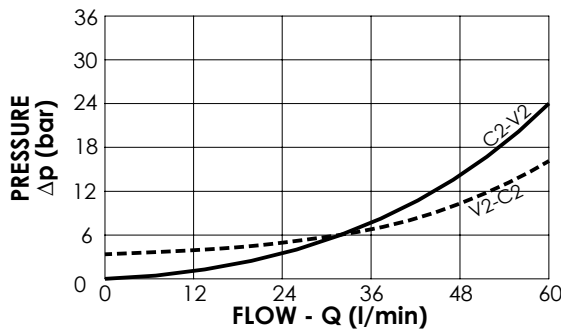
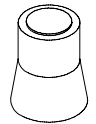

NOTES

Setting: at least 1.3 times the load induced pressure

ORDERING CODES

Quick code	Description	Pilot ratio	Main ports size	Standard setting (bar, Q=5 l/min)	Adjust. range (bar)	Pressure increase (bar/turn)
MB000002	MBSN-060-ALNR-04-G38-N350	4,2:1	V2, C2, Pil: G3/8"	350	100-350	138
MB000054	MBSN-060-ALNR-04-G38-N200	4,2:1	V2, C2, Pil: G3/8"	200	60-210	62

OVERCENTRE VALVE

MBSN-060-ALNE

SINGLE ACTING

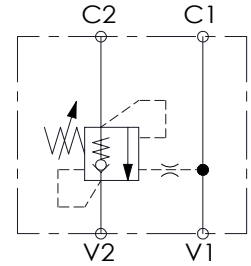
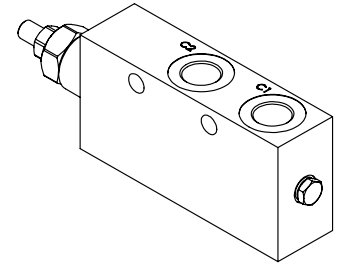
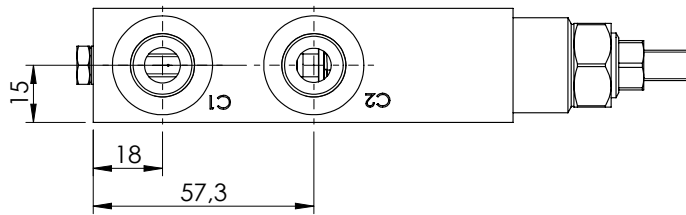
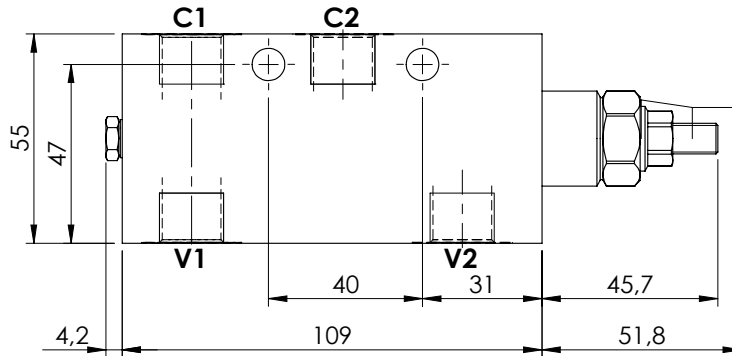
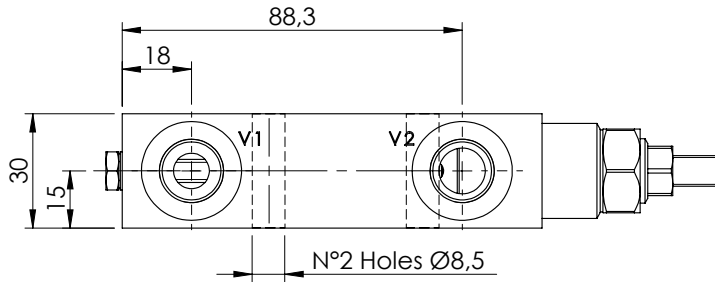

SPECIFICATIONS

Max. operating pressure:	350 bar
Rated flow:	60 l/min
Manifold:	Steel
Weight:	1,32 kg

SEALING CAP

Ordering code:
AT000020

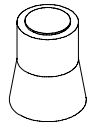

NOTES

Setting: at least 1.3 times the load induced pressure

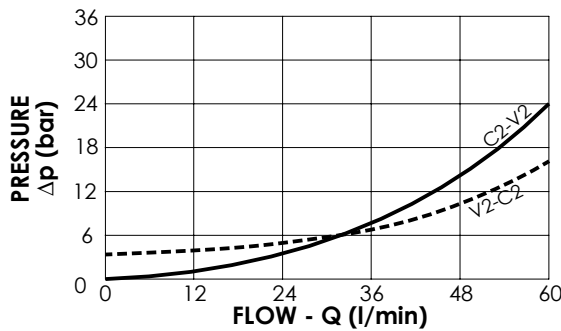

ORDERING CODES

Quick code	Description	Pilot ratio	Main ports size	Standard setting (bar, Q=5 l/min)	Adjust. range (bar)	Pressure increase (bar/turn)
MB000051	MBSN-060-ALNE-04-G38-N350	4,2:1	V1, V2: G3/8" C1, C2: G3/8"	350	100-350	138
MB000179	MBSN-060-ALNE-04-G38-N200	4,2:1	V1, V2: G3/8" C1, C2: G3/8"	200	60-250	62
MB000044	MBSN-060-ALNE-11-G38-N350	11:1	V1, V2: G3/8" C1, C2: G3/8"	350	150-350	160

OVERCENTRE VALVE

MBSN-060-ZLSE

SINGLE ACTING

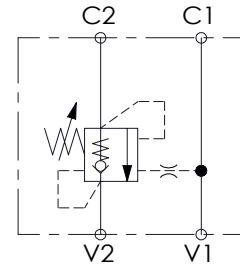
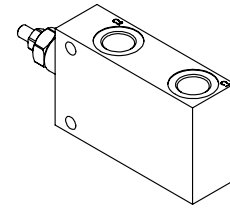
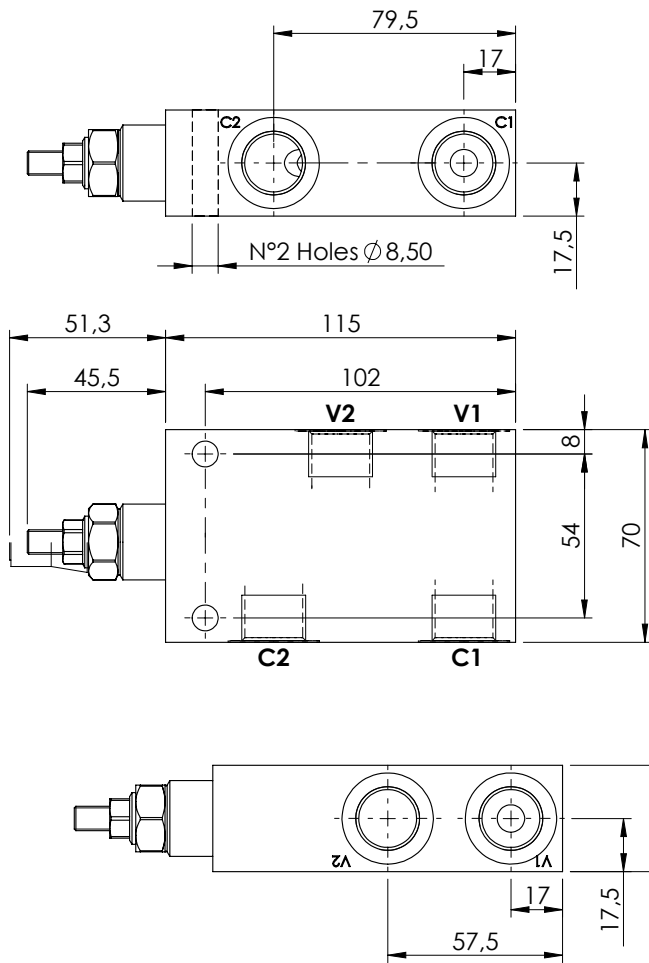

SPECIFICATIONS

Max. operating pressure: 350 bar

Rated flow: 60 l/min

Weight: Aluminium 0.8 kg; Steel 2.0 kg

SEALING CAP

Ordering code:

AT000020

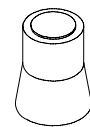

NOTES

Setting: at least 1.3 times the load induced pressure

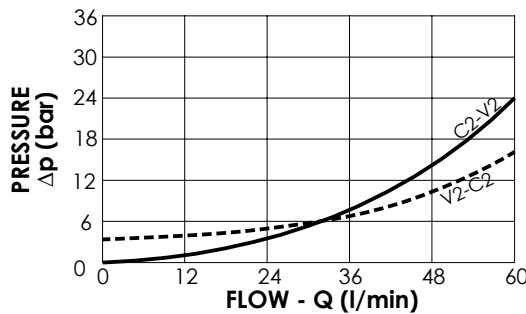

ORDERING CODES

Quick code	Description	Pilot ratio	Manifold material	Main ports size	Standard setting (bar, Q=5 l/min)	Adjust. range (bar)	Pressure increase (bar/turn)
MB000508	MBSN-060-ZLSE-04-G12-N350	4,2:1	Aluminium	V1, V2: G1/2" C1, C2: G1/2"	350	100-350	138
MB000509	MBSN-060-ZLSE-04-G12-N200	4,2:1	Aluminium	V1, V2: G1/2" C1, C2: G1/2"	200	60-210	62
MB000510	MBSN-060-ALDE-04-G12-N350	4,2:1	Steel	V1, V2: G1/2" C1, C2: G1/2"	350	100-350	138
MB000511	MBSN-060-ALDE-04-G12-N200	4,2:1	Steel	V1, V2: G1/2" C1, C2: G1/2"	200	60-210	62
MB000512	MBSN-060-ZLSE-07-G12-N350	7:1	Aluminium	V1, V2: G1/2" C1, C2: G1/2"	350	100-350	106
MB000513	MBSN-060-ZLSE-07-G12-N200	7:1	Aluminium	V1, V2: G1/2" C1, C2: G1/2"	200	60-210	46
MB000514	MBSN-060-ALDE-07-G12-N350	7:1	Steel	V1, V2: G1/2" C1, C2: G1/2"	350	100-350	106
MB000515	MBSN-060-ALDE-07-G12-N200	7:1	Steel	V1, V2: G1/2" C1, C2: G1/2"	200	60-210	46

OVERCENTRE VALVE

MBSN-060-ALNE

SINGLE ACTING

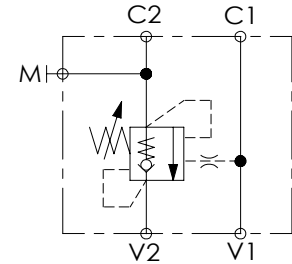
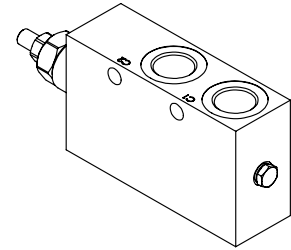
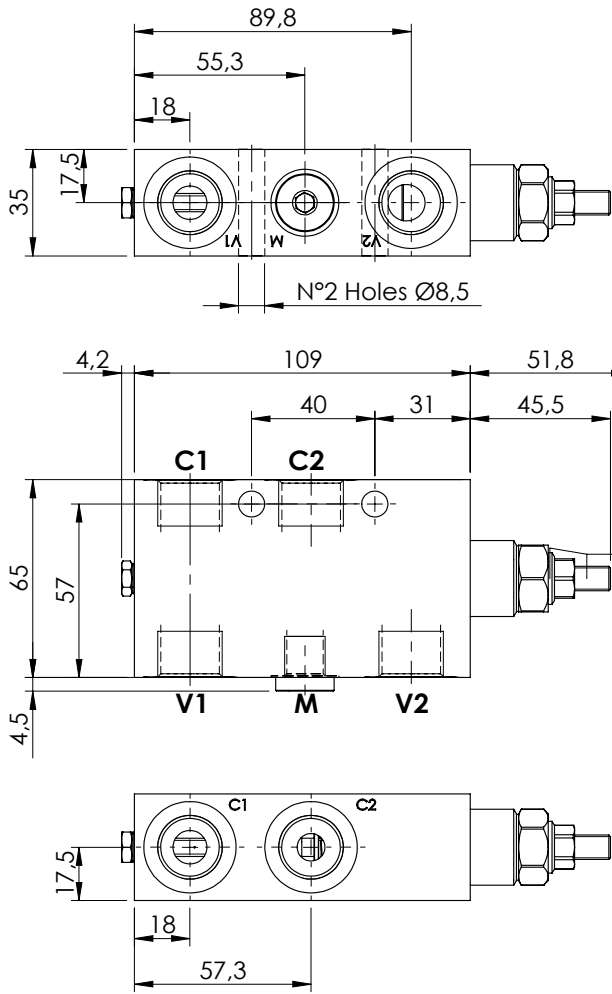

SPECIFICATIONS

Max. operating pressure:	350 bar
Rated flow:	60 l/min
Manifold:	Steel
Weight:	1,77 kg

SEALING CAP

Ordering code:
AT000020

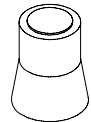

NOTES

Setting: at least 1.3 times the load induced pressure

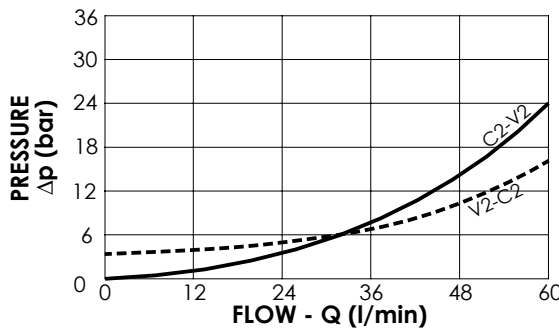

ORDERING CODES

Quick code	Description	Pilot ratio	Main ports size	Standard setting (bar, Q=5 l/min)	Adjust. range (bar)	Pressure increase (bar/turn)
MB000063	MBSN-060-ALNE-04-G12-N350	4,2:1	V1, V2: G1/2" M:G1/4" C1, C2: G1/2"	350	100-350	138
MB000200	MBSN-060-ALNE-04-G12-N200	4,2:1	V1, V2: G1/2" M:G1/4" C1, C2: G1/2"	200	60-210	62

OVERCENTRE VALVE

MBSN-060-ZLNA

SINGLE ACTING
IN LINE PORTS

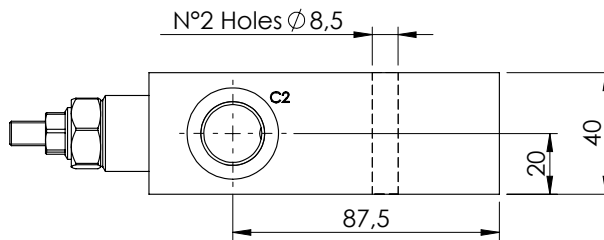
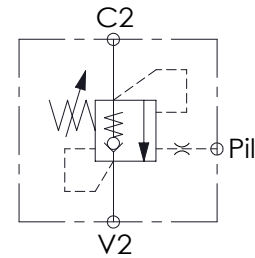
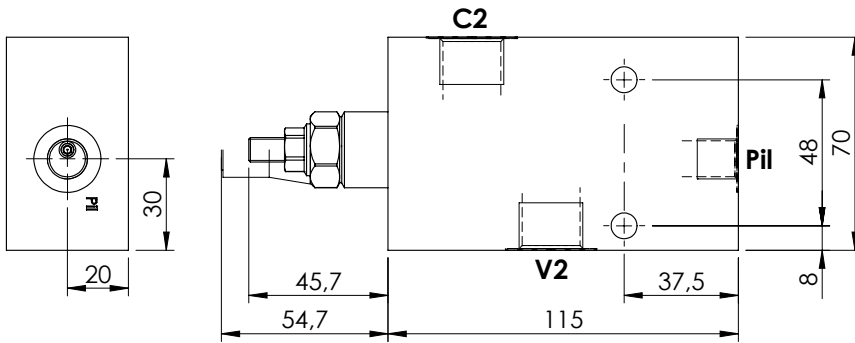
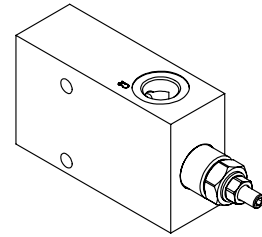
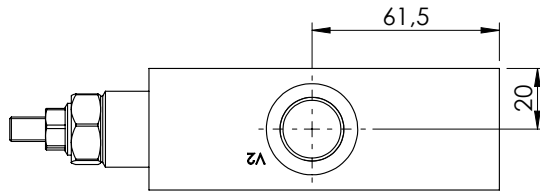

SPECIFICATIONS

Max. operating pressure:	350 bar
Rated flow:	60 l/min
Weight:	0,9 kg

SEALING CAP

Ordering code:
AT000020

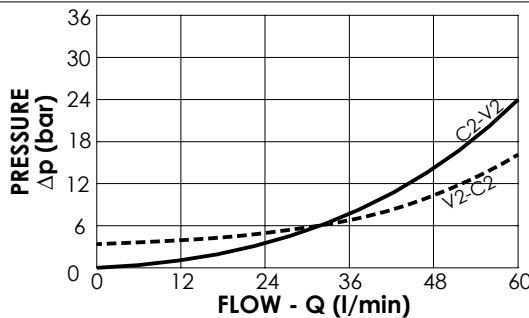
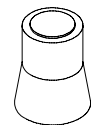

NOTES

Setting: at least 1.3 times the load induced pressure

ORDERING CODES

Quick code	Description	Pilot ratio	Manifold material	Main ports size	Standard setting (bar, Q=5 l/min)	Adjust. range (bar)	Pressure increase (bar/turn)
MB000579	MBSN-060-ZLNA-04-G12-N350	4,2:1	Aluminium	C2, V2: G 1/2" Pil: G 1/4"	350	110-350	138
MB000580	MBSN-060-ZLNA-04-G12-N200	4,2:1	Aluminium	C2, V2: G 1/2" Pil: G 1/4"	200	60-210	62
MB000581	MBSN-060-ZLNA-07-G12-N350	7:1	Aluminium	C2, V2: G 1/2" Pil: G 1/4"	350	85-350	106
MB000582	MBSN-060-ZLNA-07-G12-N250	7:1	Aluminium	C2, V2: G 1/2" Pil: G 1/4"	250	40-250	46

OVERCENTRE VALVE

MBSN-060-AANR

**SINGLE ACTING
ONE FLANGED PORT**

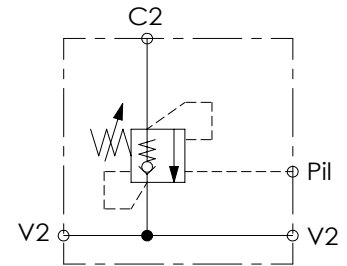
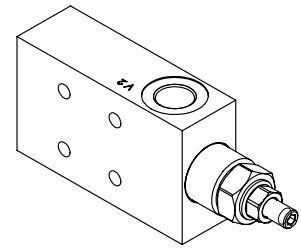
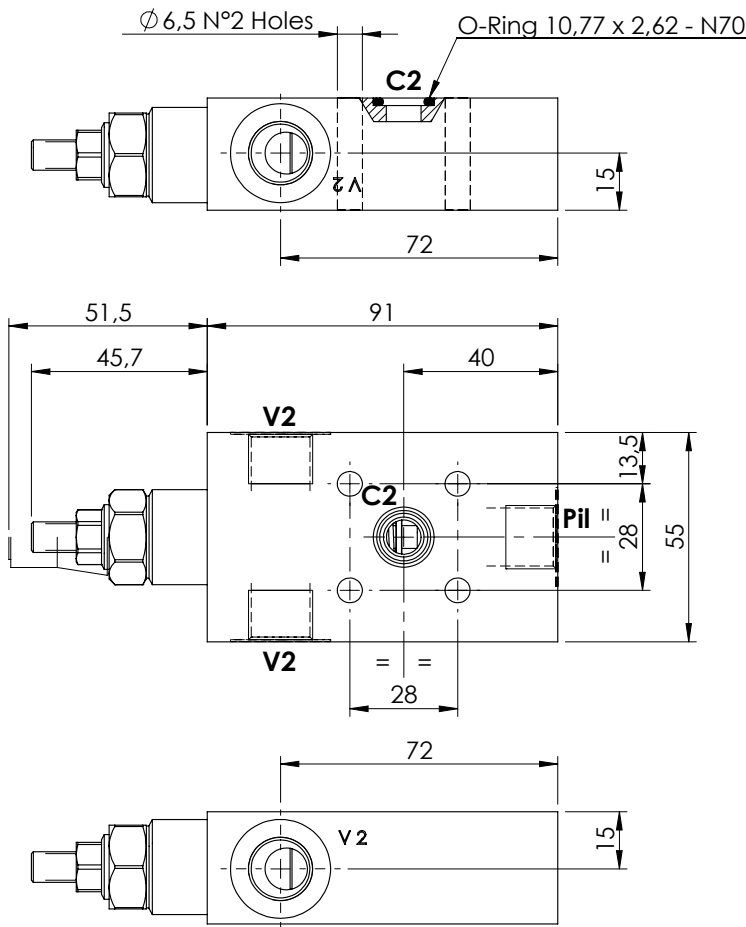

SPECIFICATIONS

Max. operating pressure:	350 bar
Rated flow:	60 l/min
Manifold:	Steel
Weight:	1,09 kg

SEALING CAP

Ordering code:
AT000020

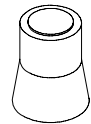

NOTES

Setting: at least 1.3 times the load induced pressure

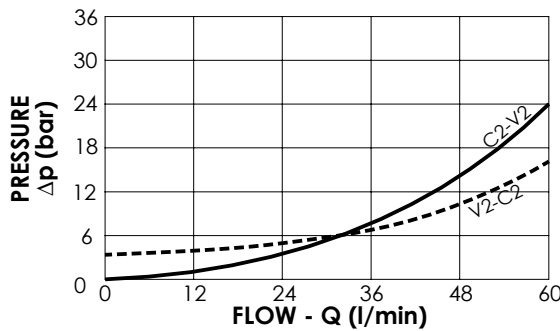

ORDERING CODES

Quick code	Description	Pilot ratio	Main ports size	Standard setting (bar, Q=5 l/min)	Adjust. range (bar)	Pressure increase (bar/turn)
MB000017	MBSN-060-AANR-04-G38-N350	4,2:1	V2, Pil: G3/8" C2 : Ø9	350	100-350	138
MB000199	MBSN-060-AANR-04-G38-N200	4,2:1	V2, Pil: G3/8" C2 : Ø9	200	60-210	62

OVERCENTRE VALVE

MBSN-060-AATV

**SINGLE ACTING
ONE FLANGED PORT**

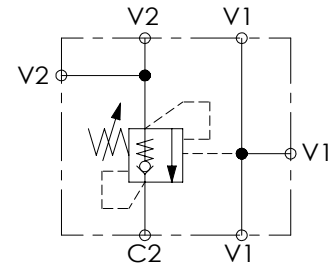
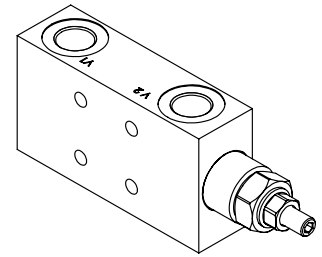
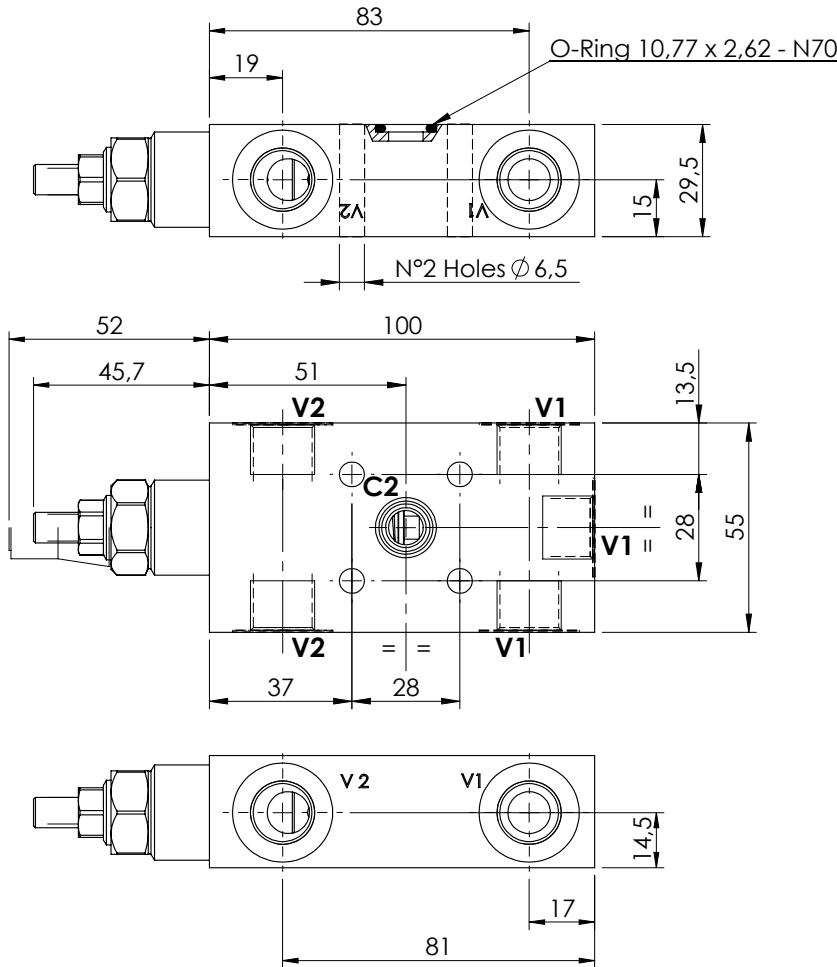

SPECIFICATIONS

Max. operating pressure:	350 bar
Rated flow:	60 l/min
Manifold:	Steel
Weight:	1,14 kg

SEALING CAP

Ordering code:
AT000020

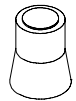

NOTES

Setting: at least 1.3 times the load induced pressure

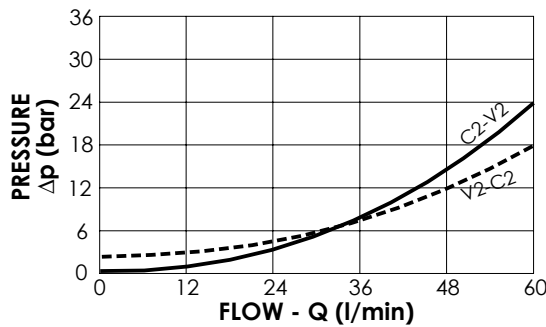

ORDERING CODES

Quick code	Description	Pilot ratio	Main ports size	Standard setting (bar, Q=5 l/min)	Adjust. range (bar)	Pressure increase (bar/turn)
MB000236	MBSN-060-AATV-04-G38-N350	4,2:1	V1,V2: G 3/8" C2: Ø 9	350	100-350	138
MB000234	MBSN-060-AATV-04-G38-N200	4,2:1	V1,V2: G 3/8" C2: Ø 9	200	60-210	62

OVERCENTRE VALVE

MBSN-060-ABNP

**SINGLE ACTING
TWO FLANGED PORTS**

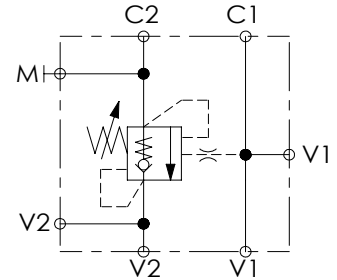
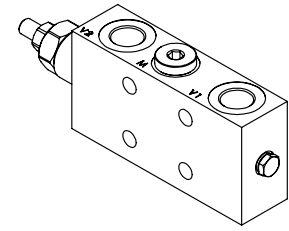
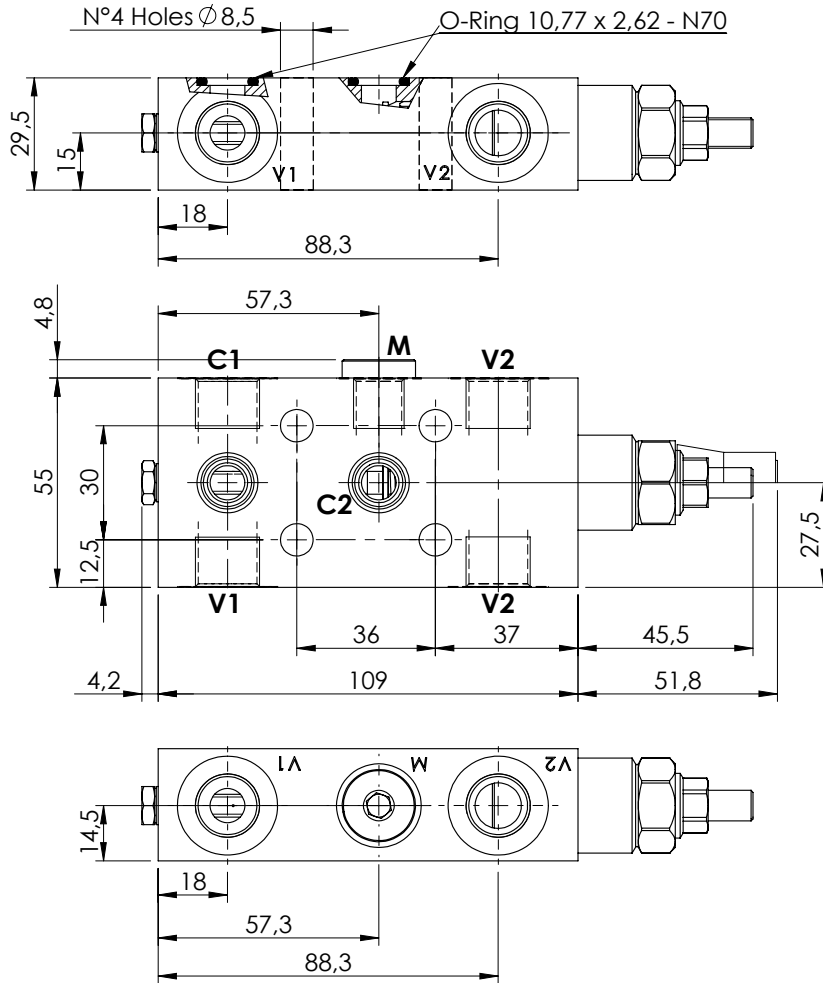

SPECIFICATIONS

Max. operating pressure:	350 bar
Rated flow:	60 l/min
Manifold:	Steel
Weight:	1,27 kg

SEALING CAP

Ordering code:
AT000020

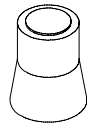

NOTES

Setting: at least 1.3 times the load induced pressure

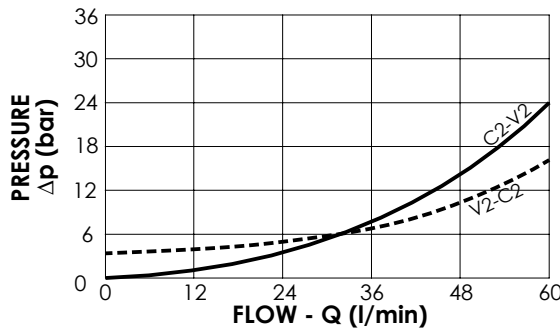

ORDERING CODES

Quick code	Description	Pilot ratio	Main ports size	Standard setting (bar, Q=5 l/min)	Adjust. range (bar)	Pressure increase (bar/turn)
MB000139	MBSN-060-ABNP-04-G38-N350	4,2:1	V1, V2: G3/8" M:G1/4" C1, C2: $\varnothing 9$	350	100-350	138
MB000914	MBSN-060-ABNP-04-G38-N200	4,2:1	V1, V2: G3/8" M:G1/4" C1, C2: $\varnothing 9$	200	60-210	62

OVERCENTRE VALVE

MBSN-060-ABNP

SINGLE ACTING
TWO FLANGED PORTS

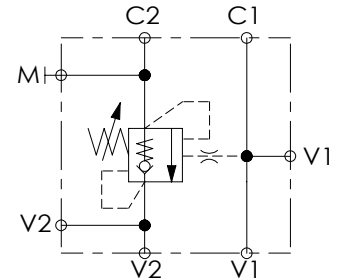
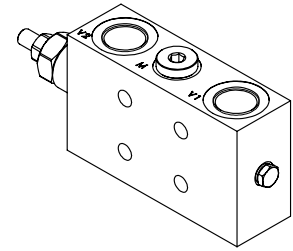
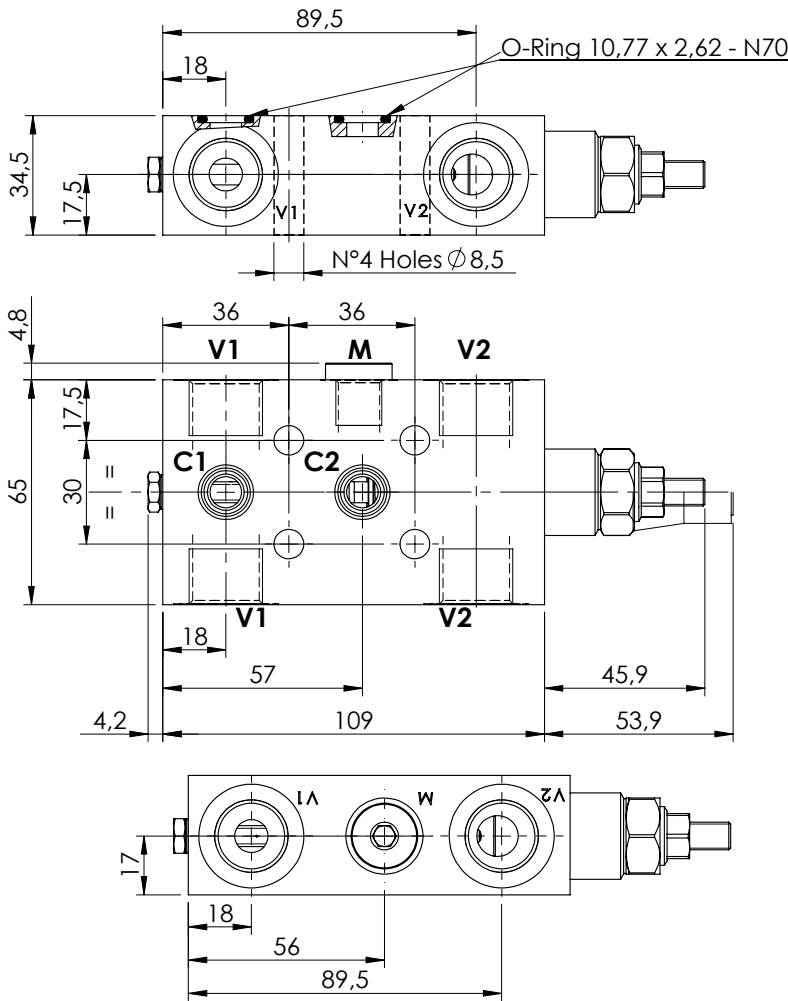

SPECIFICATIONS

Max. operating pressure:	350 bar
Rated flow:	60 l/min
Manifold:	Steel
Weight:	1,69 kg

SEALING CAP

Ordering code:
AT000020

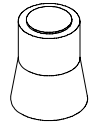

NOTES

Setting: at least 1.3 times the load induced pressure

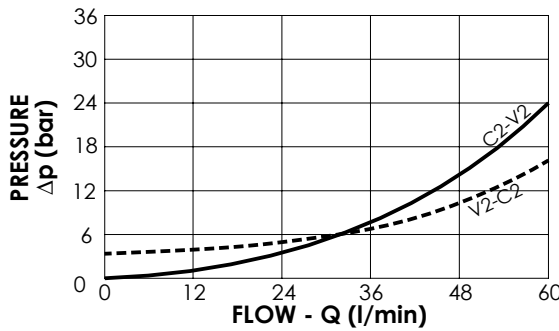

ORDERING CODES

Quick code	Description	Pilot ratio	Main ports size	Standard setting (bar, Q=5 l/min)	Adjust. range (bar)	Pressure increase (bar/turn)
MB000140	MBSN-060-ABNP-04-G12-N350	4,2:1	V1, V2 : G1/2" M: G1/4" C1, C2 : Ø9	350	100-350	138

OVERCENTRE VALVE

MBSN-150-ALNV

SINGLE ACTING

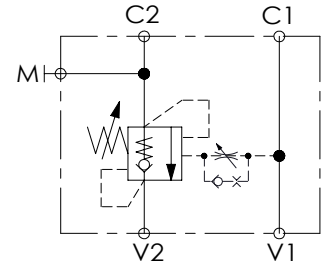
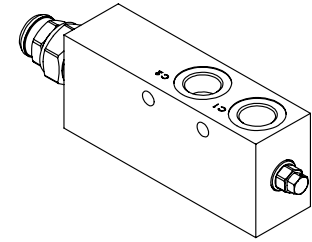
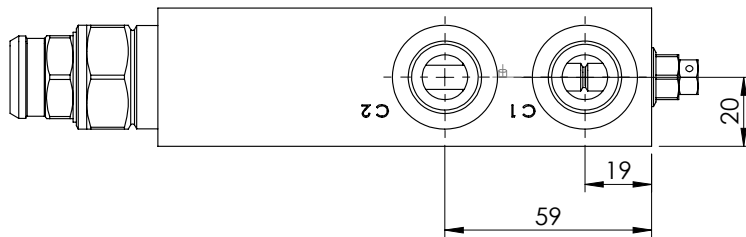
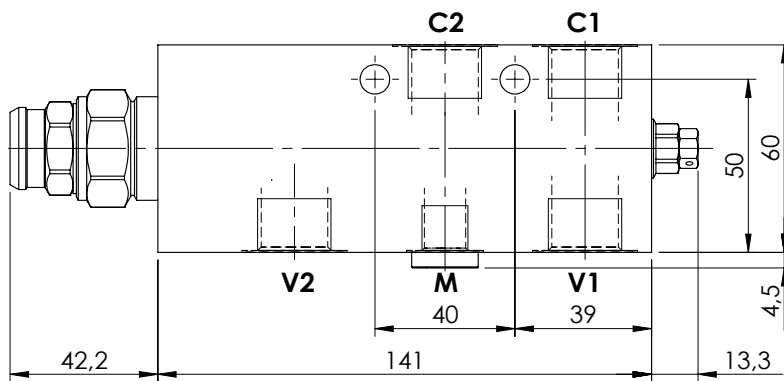
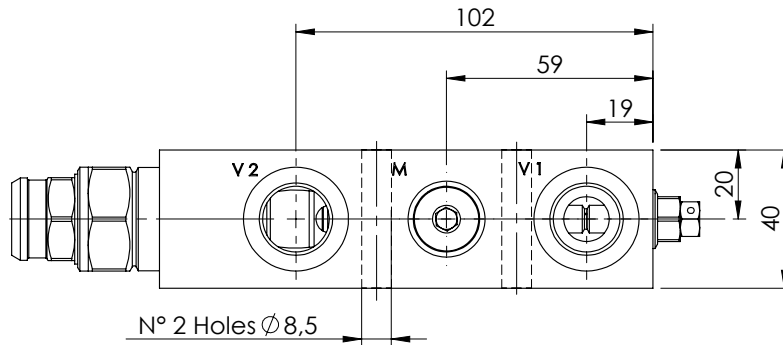

SPECIFICATIONS

Max. operating pressure:	350 bar
Rated flow:	150 l/min
Manifold:	Steel
Weight:	2,49 kg

SEALING CAP

Ordering code:
ST000012

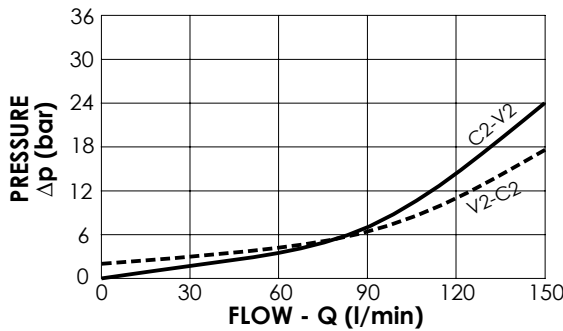
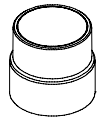

NOTES

Setting: at least 1.3 times the load induced pressure

ORDERING CODES

Quick code	Description	Pilot ratio	Main ports size	Standard setting (bar, Q=5 l/min)	Adjust. range (bar)	Pressure increase (bar/turn)
MB000047	MBSN-150-ALNV-04-G12-N350	4:1	V1,V2: G 1/2" M: G1/4" C1, C2: G1/2"	350	100-350	104

OVERCENTRE VALVE

MBSN-150-ALNV

SINGLE ACTING

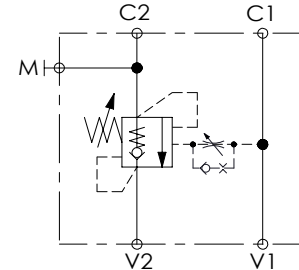
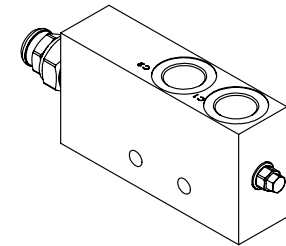
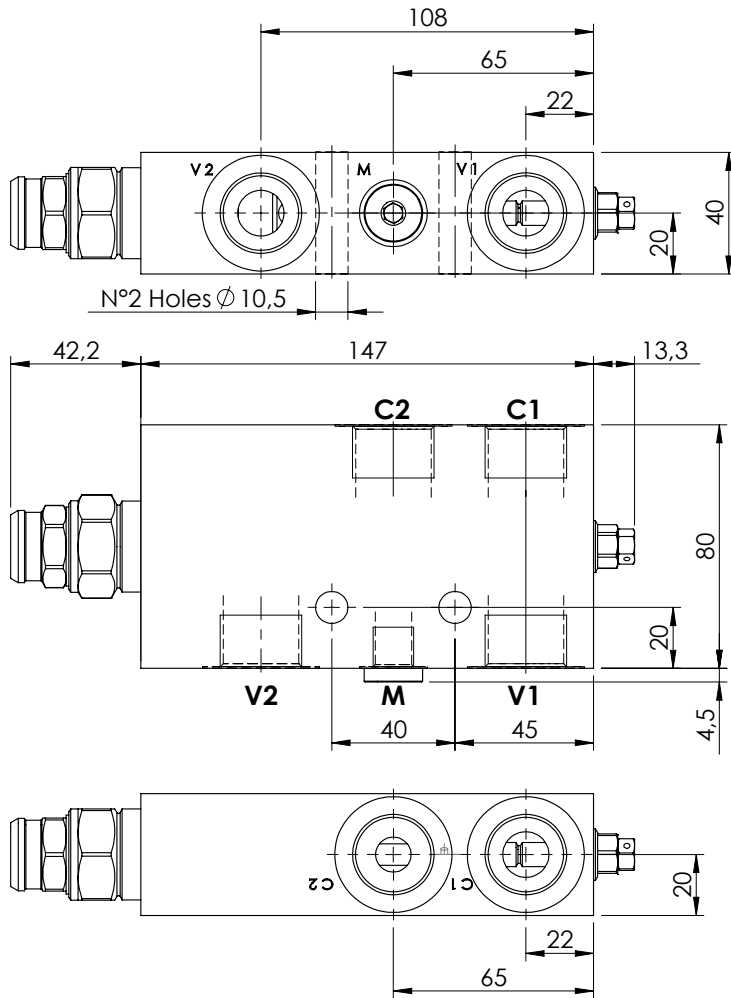

SPECIFICATIONS

Max. operating pressure:	350 bar
Rated flow:	150 l/min
Manifold:	Steel
Weight:	3,25 kg

SEALING CAP

Ordering code:
ST000012

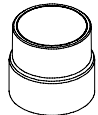

NOTES

Setting: at least 1.3 times the load induced pressure

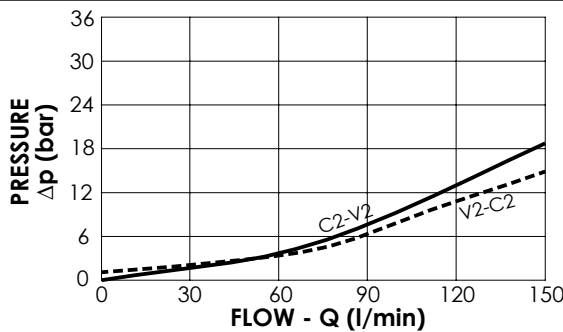

ORDERING CODES

Quick code	Description	Pilot ratio	Main ports size	Standard setting (bar, Q=5 l/min)	Adjust. range (bar)	Pressure increase (bar/turn)
MB000215	MBSN-150-ALNV-04-G34-N350	4:1	V1, V2: G3/4" M:G1/4" C1, C2: G3/4"	350	100-350	104

OVERCENTRE VALVE

MBSN-150-AANV

**SINGLE ACTING
ONE FLANGED PORT**

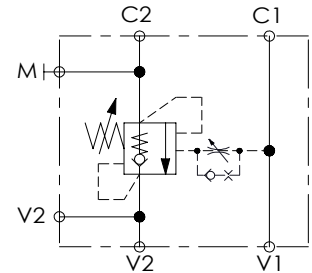
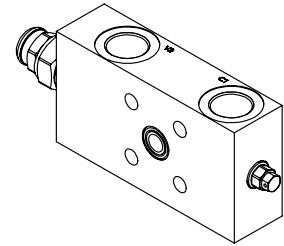
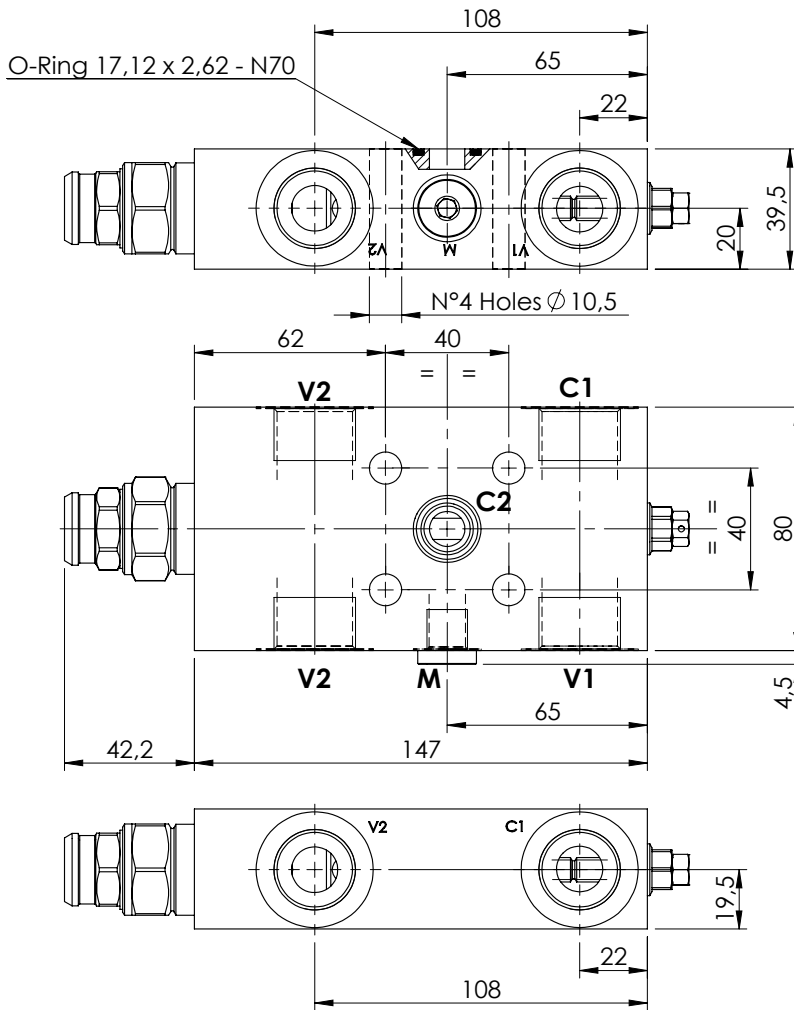

SPECIFICATIONS

Max. operating pressure:	350 bar
Rated flow:	150 l/min
Manifold:	Steel
Weight:	3,14 kg

SEALING CAP

Ordering code:
ST000012

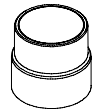

NOTES

Setting: at least 1.3 times the load induced pressure

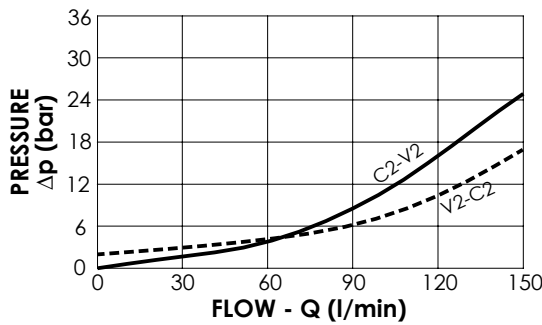

ORDERING CODES

Quick code	Description	Pilot ratio	Main ports size	Standard setting (bar, Q=5 l/min)	Adjust. range (bar)	Pressure increase (bar/turn)
MB000426	MBSN-150-AANV-04-G34-N350	4:1	V1, V2, C1: G3/4" M: G1/4" C2: \varnothing 11.5	350	100-350	104

OVERCENTRE VALVE

MBSN-150-ABNV

**SINGLE ACTING
TWO FLANGED PORTS**

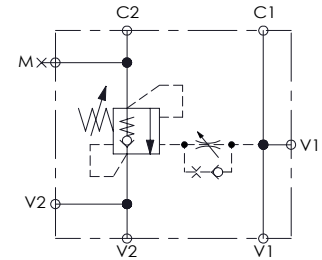
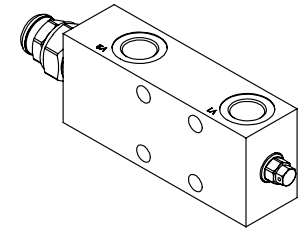
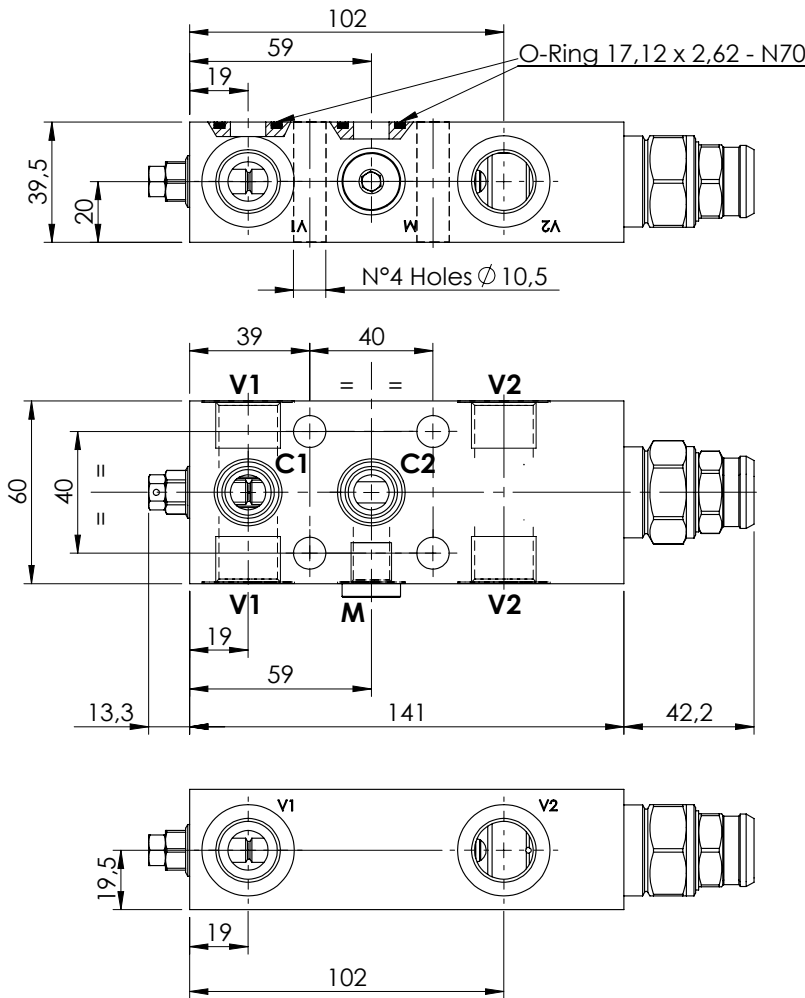

SPECIFICATIONS

Max. operating pressure:	350 bar
Rated flow:	150 l/min
Manifold:	Steel
Weight:	2,37 kg

SEALING CAP

Ordering code:
ST000012

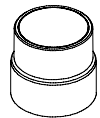

NOTES

Setting: at least 1.3 times the load induced pressure

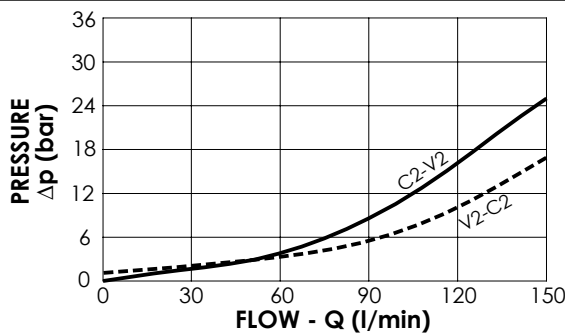

ORDERING CODES

Quick code	Description	Pilot ratio	Main ports size	Standard setting (bar, Q=5 l/min)	Adjust. range (bar)	Pressure increase (bar/turn)
MB000156	MBSN-150-ABNV-04-G12-N350	4:1	V1, V2: G1/2" M:G1/4" C1, C2: Ø11.5	350	100-350	104
MB000883	MBSN-150-ABNV-08-G12-N350	8:1	V1, V2: G1/2" M:G1/4" C1, C2: Ø11.5	350	100-350	84

OVERCENTRE VALVE

MBSN-150-ABNV

**SINGLE ACTING
TWO FLANGED PORTS**

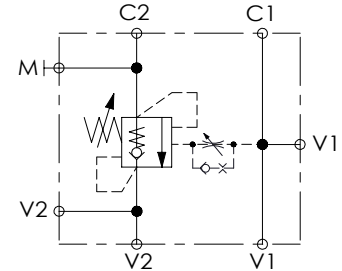
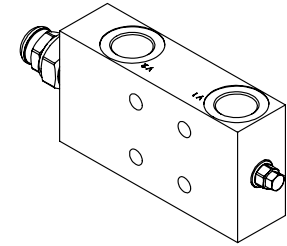
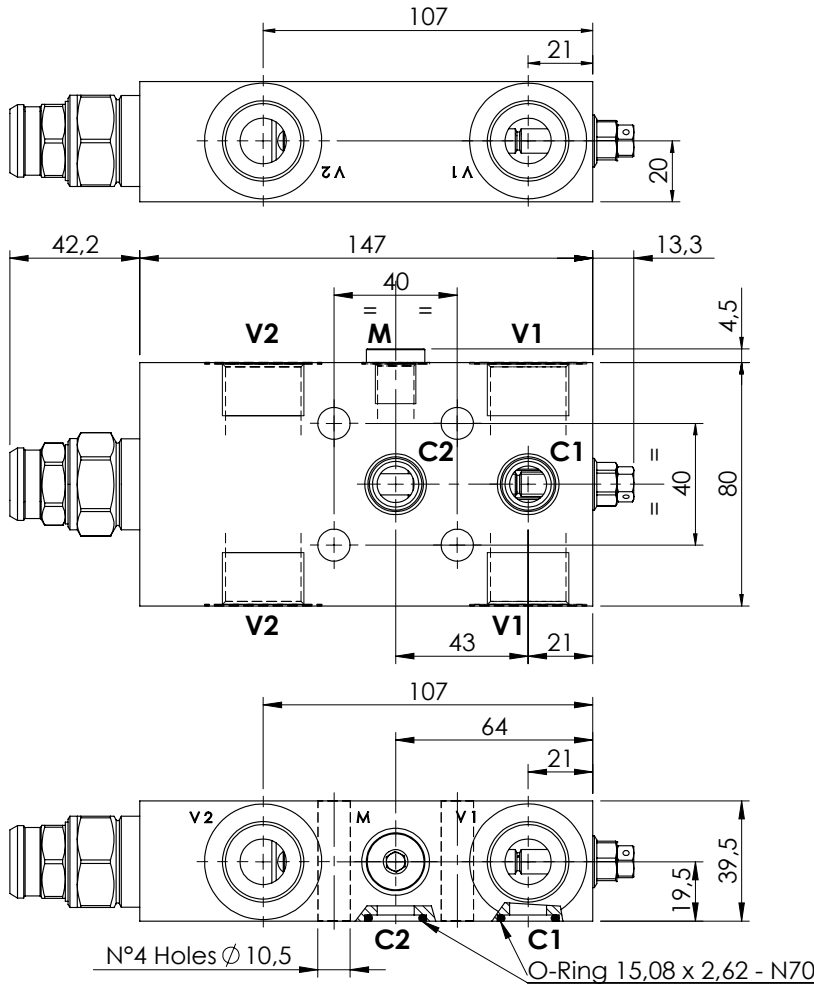

SPECIFICATIONS

Max. operating pressure:	350 bar
Rated flow:	150 l/min
Manifold:	Steel
Weight:	3,13 kg

SEALING CAP

Ordering code:
ST000012

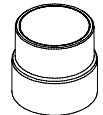

NOTES

Setting: at least 1.3 times the load induced pressure

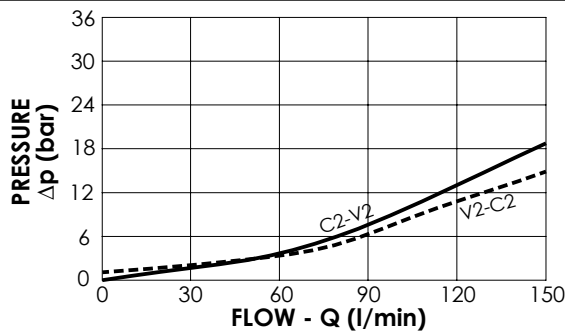

ORDERING CODES

Quick code	Description	Pilot ratio	Main ports size	Standard setting (bar, Q=5 l/min)	Adjust. range (bar)	Pressure increase (bar/turn)
MB000216	MBSN-150-ABNV-04-G34-N350	4:1	V1, V2: G3/4" M: G1/4" C1, C2: Ø12	350	100-350	104

OVERCENTRE VALVE

MBSN-300-ZLNP

SINGLE ACTING
IN LINE PORTS

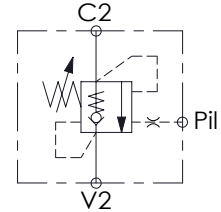
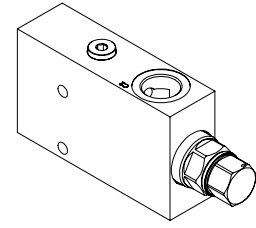
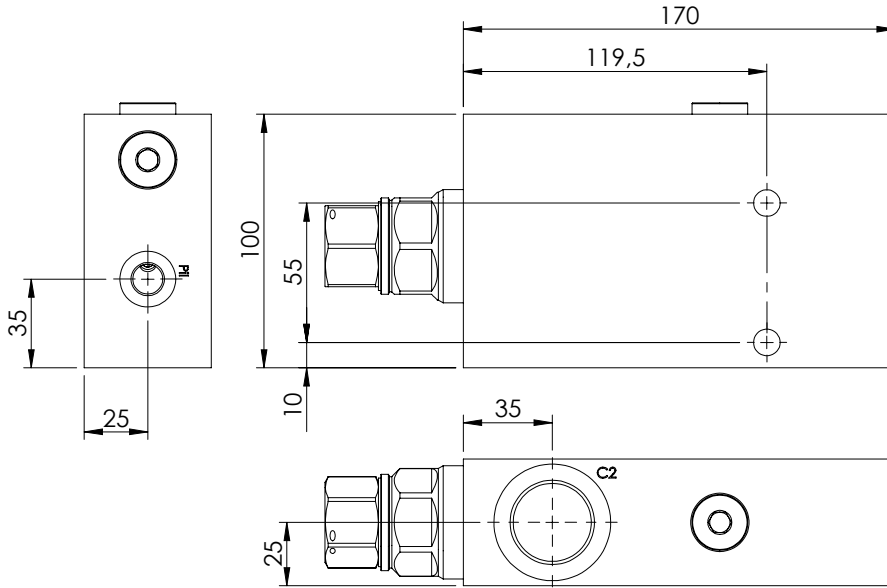
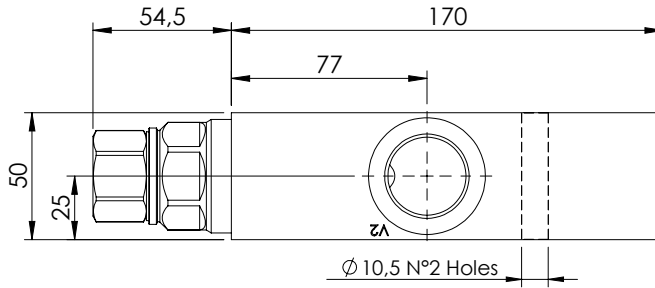

SPECIFICATIONS

Max. operating pressure: **350 bar**

Rated flow: **300 l/min**

Weight: Aluminium 2,61 kg; Steel 6,14 kg

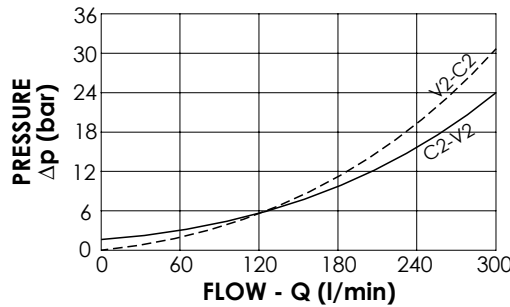

NOTES

Setting: at least 1.3 times the load induced pressure

ORDERING CODES

Quick code	Description	Pilot ratio	Manifold material	Main ports size	Standard setting (bar, Q=5 l/min)	Adjust. range (bar)	Pressure increase (bar/turn)
MB000720	MBSN-300-ZLNP-04-G10-N350	4:1	Aluminium	C2, V2: G 1" Pil: G 1/4"	350	100-350	75
MB000834	MBSN-300-ALNP-04-G10-N350	4:1	Steel	C2, V2: G 1" Pil: G 1/4"	350	100-350	75
MB000836	MBSN-300-ALNP-04-G10-N200	4:1	Steel	C2, V2: G 1" Pil: G 1/4"	200	60-210	46

OVERCENTRE VALVE

MBSP-060-ZLSE

**SINGLE ACTING
RELIEF COMPENSATED**

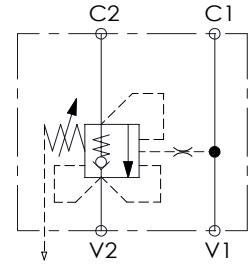
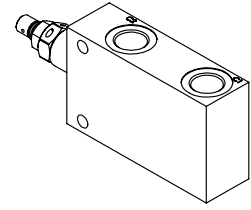
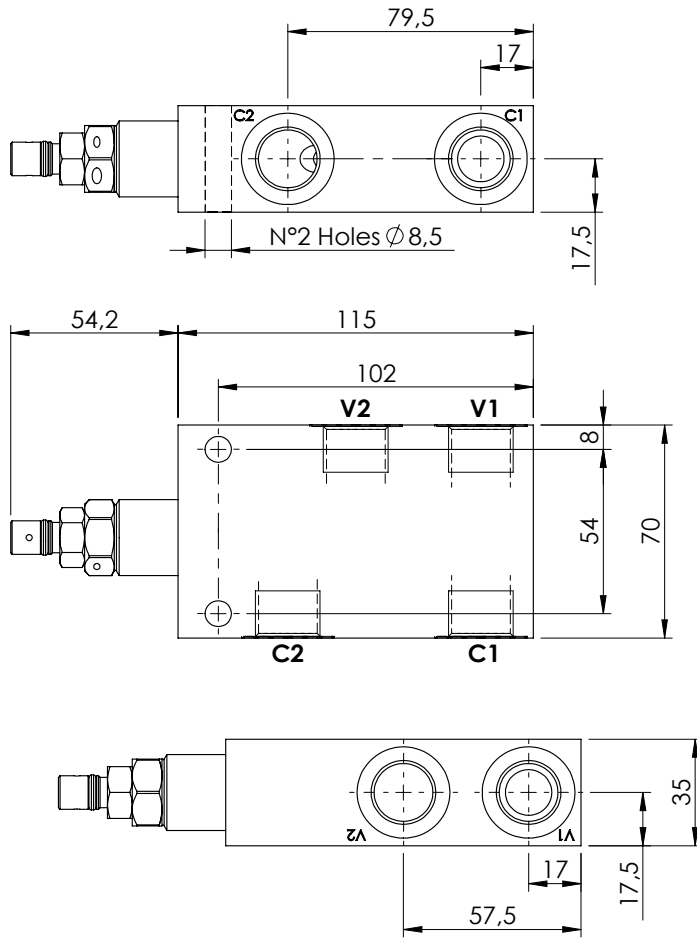

SPECIFICATIONS

Max. operating pressure:	350 bar
Rated flow:	60 l/min
Manifold:	Aluminium
Weight:	0,8 Kg

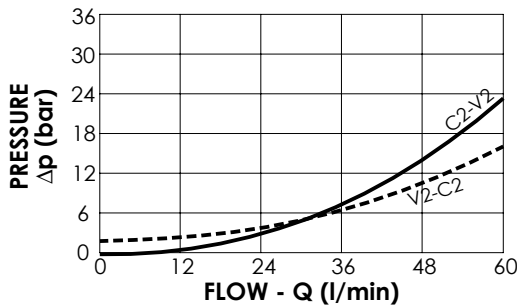

NOTES

Setting: at least 1.3 times the load induced pressure

ORDERING CODES

Quick code	Description	Pilot ratio	Main ports size	Standard setting (bar, Q=5 l/min)	Adjust. range (bar)	Pressure increase (bar/turn)
MB000722	MBSP-060-ZLSE-04-G12-N350	4,2:1	V1, V2: G1/2" C1, C2: G1/2"	350	100-350	138

OVERCENTRE VALVE

MBSP-060-ALNP

**SINGLE ACTING
RELIEF COMPENSATED**

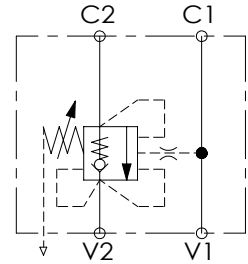
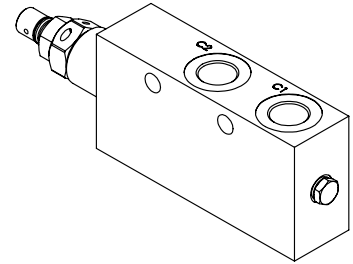
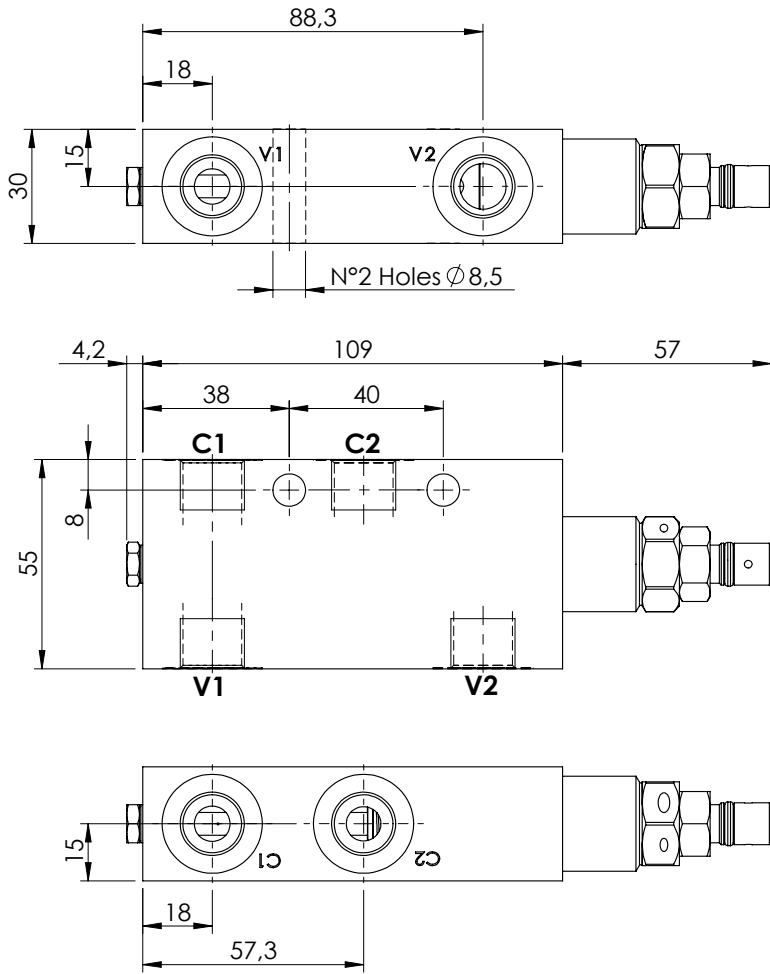

SPECIFICATIONS

Max. operating pressure:	350 bar
Rated flow:	60 l/min
Manifold:	Steel
Weight:	1,35 kg

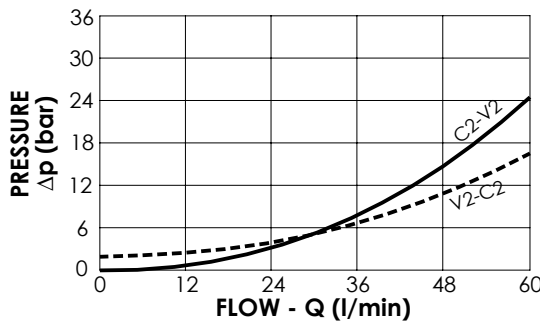

NOTES

Setting: at least 1.3 times the load induced pressure

ORDERING CODES

Quick code	Description	Pilot ratio	Main ports size	Standard setting (bar, Q=5 l/min)	Adjust. range (bar)	Pressure increase (bar/turn)
MB000209	MBSP-060-ALNP-04-G38-N350	4,2:1	V1, V2: G3/8" C1, C2: G3/8"	350	100-350	166
MB000896	MBSP-060-ALNP-04-G38-N200	4,2:1	V1, V2: G3/8" C1, C2: G3/8"	200	60-210	75

OVERCENTRE VALVE

MBSN-060-ABNE

**SINGLE ACTING
TWO FLANGED PORTS
RELIEF COMPENSATED**

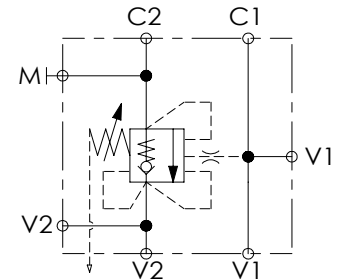
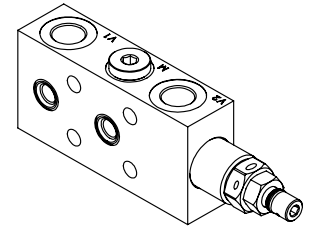
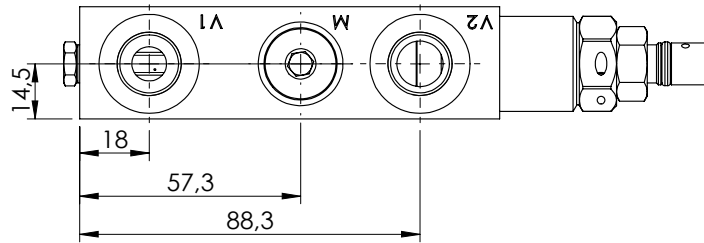
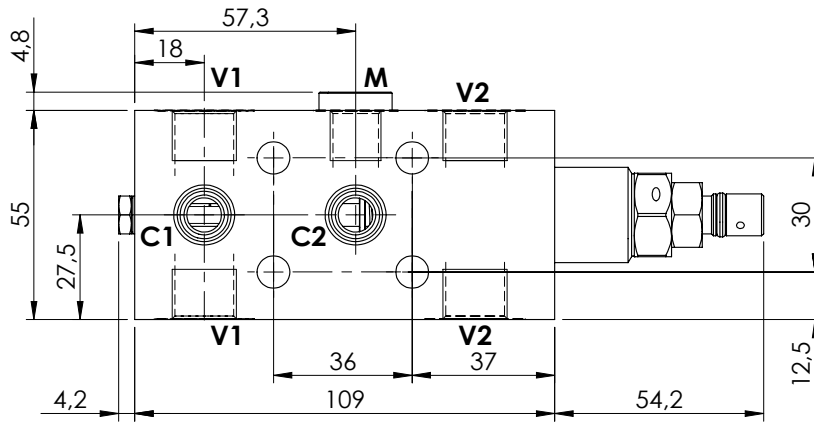
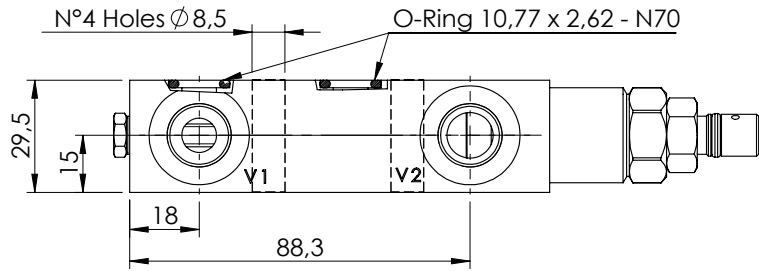

SPECIFICATIONS

Max. operating pressure:	350 bar
Rated flow:	60 l/min
Manifold:	Steel
Weight:	1,29 kg

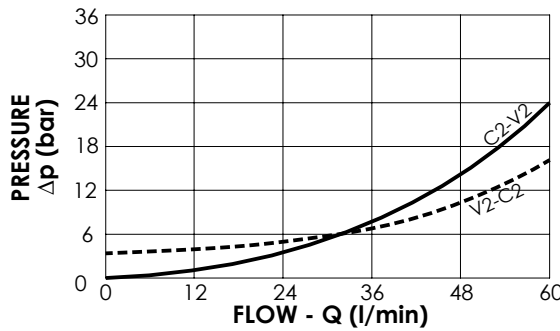

NOTES

Setting: at least 1.3 times the load induced pressure

ORDERING CODES

Quick code	Description	Pilot ratio	Main ports size	Standard setting (bar, Q=5 l/min)	Adjust. range (bar)	Pressure increase (bar/turn)
MB000473	MBSP-060-ABNE-04-G38-N350	4,2:1	V1, V2: G3/8" M:G1/4" C1, C2: Ø 9	350	100-350	166
MB001018	MBSP-060-ABNE-04-G38-N200	4,2:1	V1, V2: G3/8" M:G1/4" C1, C2: Ø 9	200	60-210	75

OVERCENTRE VALVE

MBSP-060-ABNP

**SINGLE ACTING
TWO FLANGED PORTS
RELIEF COMPENSATED**

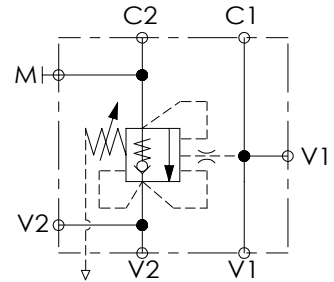
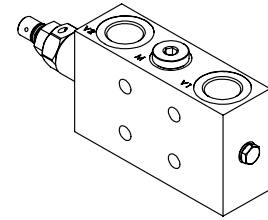
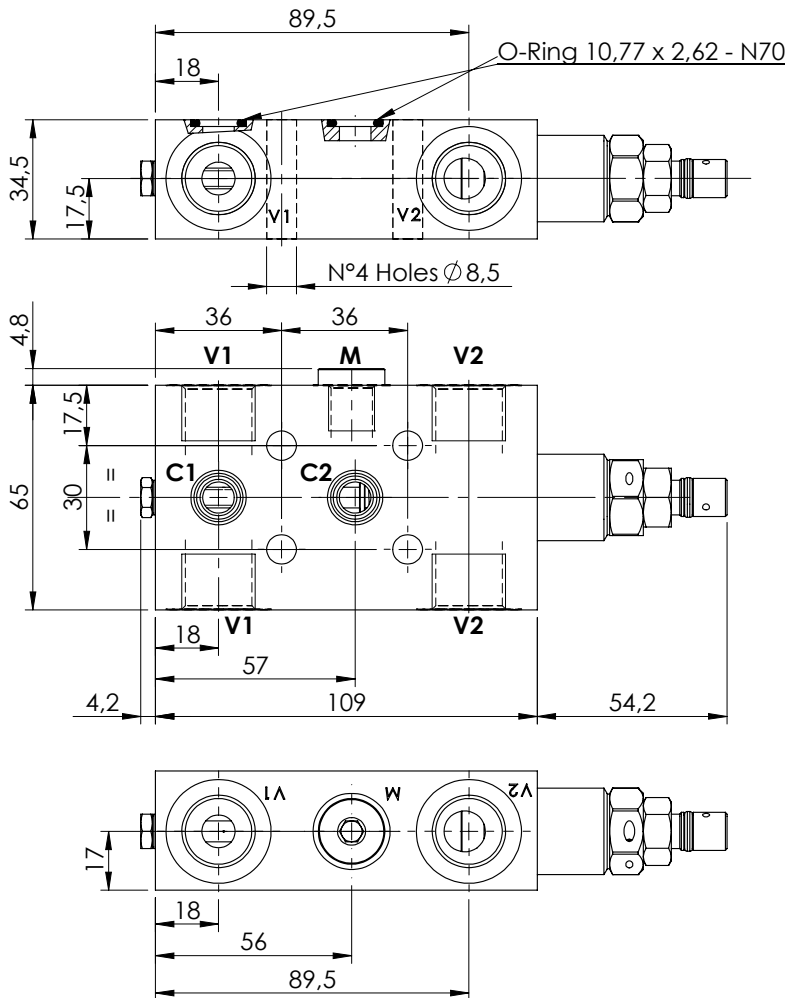

SPECIFICATIONS

Max. operating pressure:	350 bar
Rated flow:	60 l/min
Manifold:	Steel
Weight:	1,72 kg

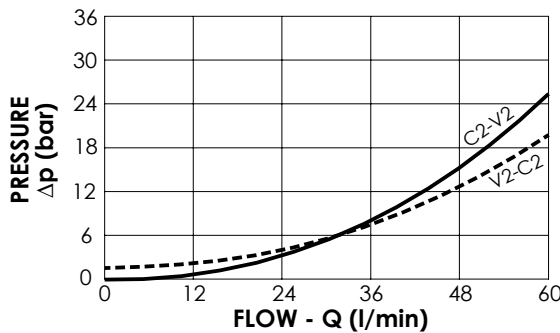

NOTES

Setting: at least 1.3 times the load induced pressure

ORDERING CODES

Quick code	Description	Pilot ratio	Main ports size	Standard setting (bar, Q=5 l/min)	Adjust. range (bar)	Pressure increase (bar/turn)
MB000335	MBSP-060-ABNP-04-G12-N350	4,2:1	V1, V2 : G1/2" M: G1/4" C1, C2 : Ø9	350	100-350	138

OVERCENTRE VALVE

MBSP-150-ZLSE

**SINGLE ACTING
RELIEF COMPENSATED**

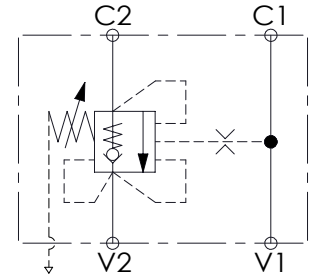
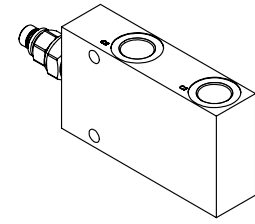
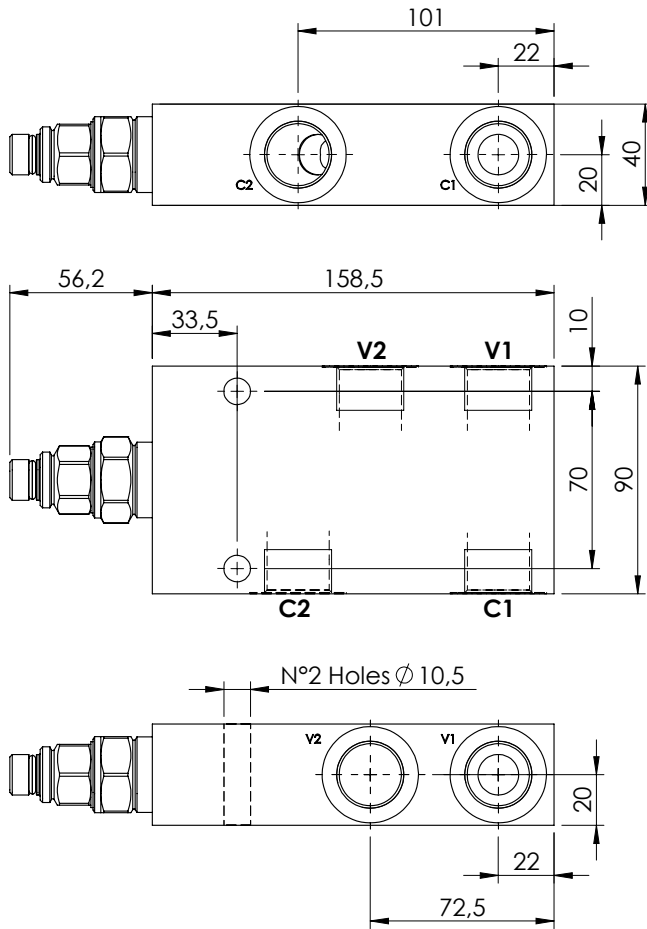

SPECIFICATIONS

Max. operating pressure:	350 bar
Rated flow:	150 l/min
Weight:	Aluminium 1,6 kg; Steel 3.9 kg

NOTES

Setting: at least 1.3 times the load induced pressure

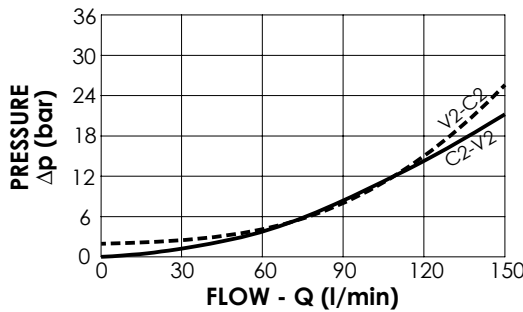

ORDERING CODES

Quick code	Description	Pilot ratio	Manifold material	Main ports size	Standard setting (bar, Q=5 l/min)	Adjust. range (bar)	Pressure increase (bar/turn)
MB000500	MBSP-150-ZLSE-08-G34-N350	8:1	Aluminium	V1, V2: G3/4" C1, C2: G3/4"	350	100-350	83
MB000501	MBSP-150-ZLSE-08-G34-N200	8:1	Aluminium	V1, V2: G3/4" C1, C2: G3/4"	200	60-210	47
MB000502	MBSP-150-ALDE-08-G34-N350	8:1	Steel	V1, V2: G3/4" C1, C2: G3/4"	350	100-350	83
MB000503	MBSP-150-ALDE-08-G34-N200	8:1	Steel	V1, V2: G3/4" C1, C2: G3/4"	200	60-210	47
MB000504	MBSP-150-ZLSE-04-G34-N350	4:1	Aluminium	V1, V2: G3/4" C1, C2: G3/4"	350	100-350	104
MB000505	MBSP-150-ZLSE-04-G34-N200	4:1	Aluminium	V1, V2: G3/4" C1, C2: G3/4"	200	60-210	56
MB000506	MBSP-150-ALDE-04-G34-N350	4:1	Steel	V1, V2: G3/4" C1, C2: G3/4"	350	100-350	104
MB000507	MBSP-150-ALDE-04-G34-N200	4:1	Steel	V1, V2: G3/4" C1, C2: G3/4"	200	60-210	56

OVERCENTRE VALVE

MBST-150-AANV

**SINGLE ACTING
ONE FLANGED PORT
FULLY COMPENSATED**

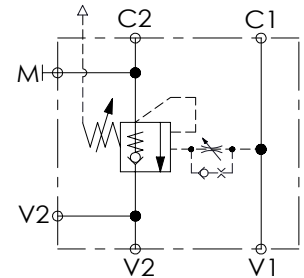
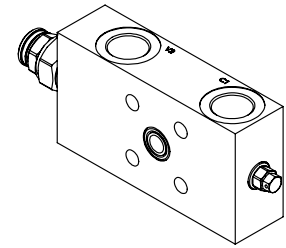
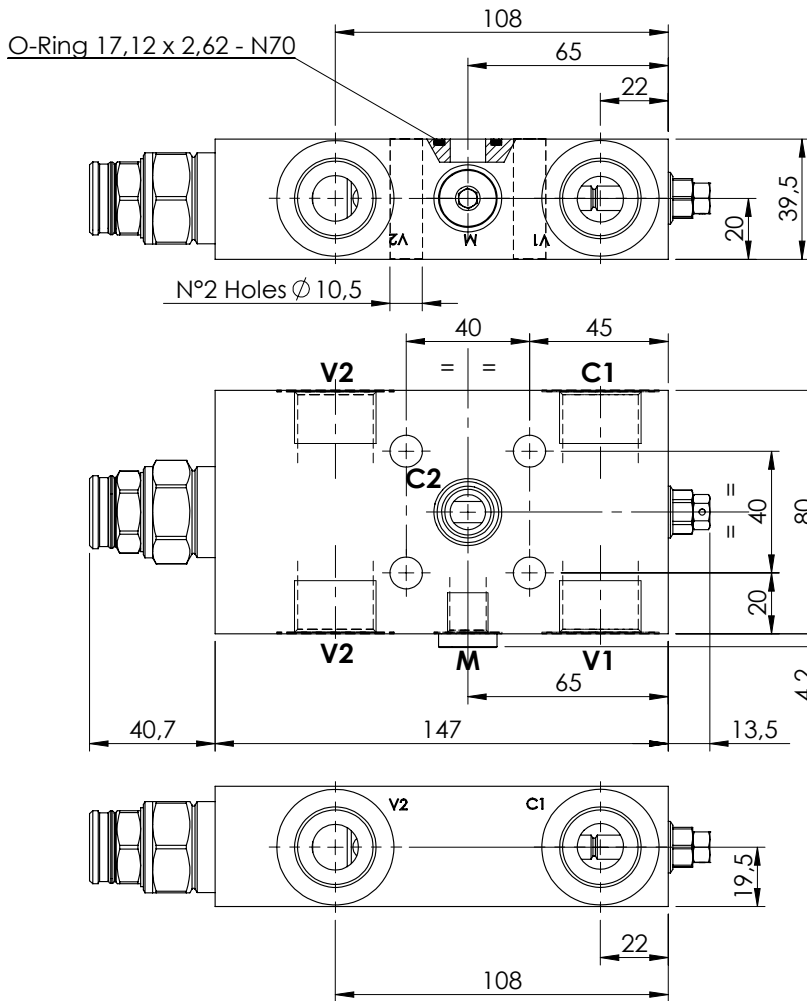

SPECIFICATIONS

Max. operating pressure:	350 bar
Rated flow:	150 l/min
Manifold:	Steel
Weight:	3,13 kg

SEALING CAP

Ordering code:
ST00012



NOTES

Setting: at least 1.3 times the load induced pressure

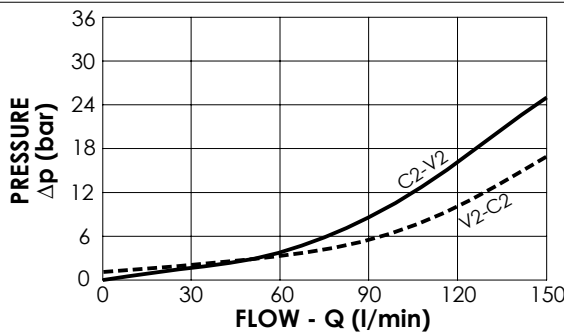

ORDERING CODES

Quick code	Description	Pilot ratio	Main ports size	Standard setting (bar, Q=5 l/min)	Adjust. range (bar)	Pressure increase (bar/turn)
MB000267	MBST-150-AANV-04-G34-N350	4:1	V1, V2, C1: G3/4" M: G1/4" C2: Ø11.5	350	100-350	104

OVERCENTRE VALVE

MBST-150-ABNV

**SINGLE ACTING
TWO FLANGED PORTS
FULLY COMPENSATED**

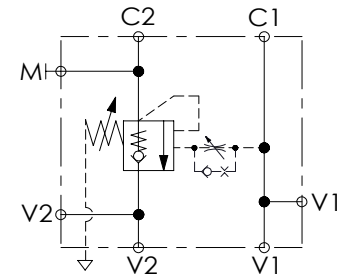
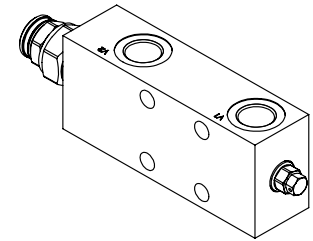
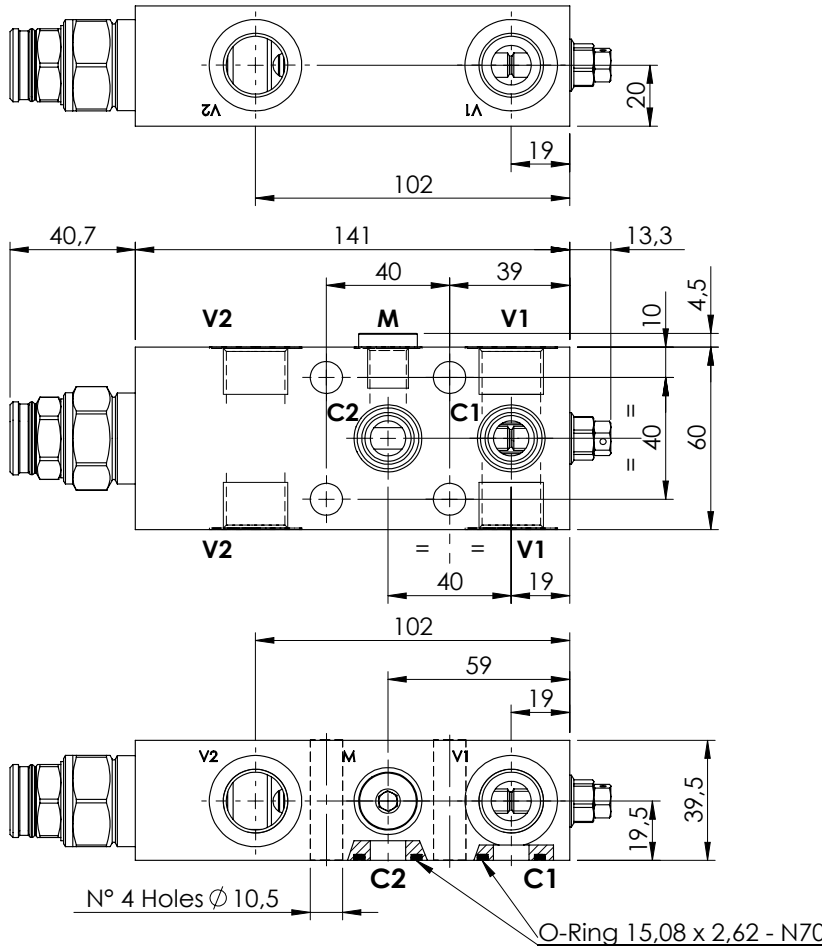

SPECIFICATIONS

Max. operating pressure:	350 bar
Rated flow:	150 l/min
Manifold:	Steel
Weight:	2,36 kg

SEALING CAP

Ordering code:
ST000012

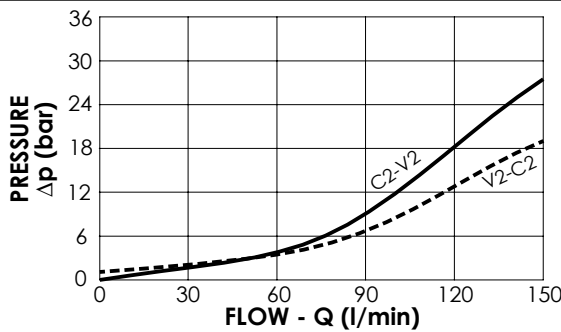
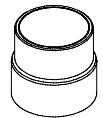

NOTES

Setting: at least 1.3 times the load induced pressure

ORDERING CODES

Quick code	Description	Pilot ratio	Main ports size	Standard setting (bar, Q=5 l/min)	Adjust. range (bar)	Pressure increase (bar/turn)
MB000214	MBST-150-ABNV-04-G12-N350	4:1	V1, V2: G1/2" M:G1/4" C1, C2: Ø11.5	350	100-350	104
MB000667	MBST-150-ABNV-08-G12-N350	8:1	V1, V2: G1/2" M:G1/4" C1, C2: Ø11.5	350	100-350	101

OVERCENTRE VALVE

MBST-150-ABNV

**SINGLE ACTING
TWO FLANGED PORTS
FULLY COMPENSATED**

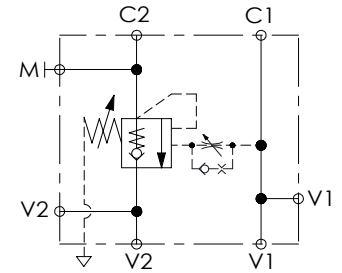
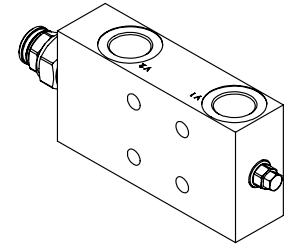
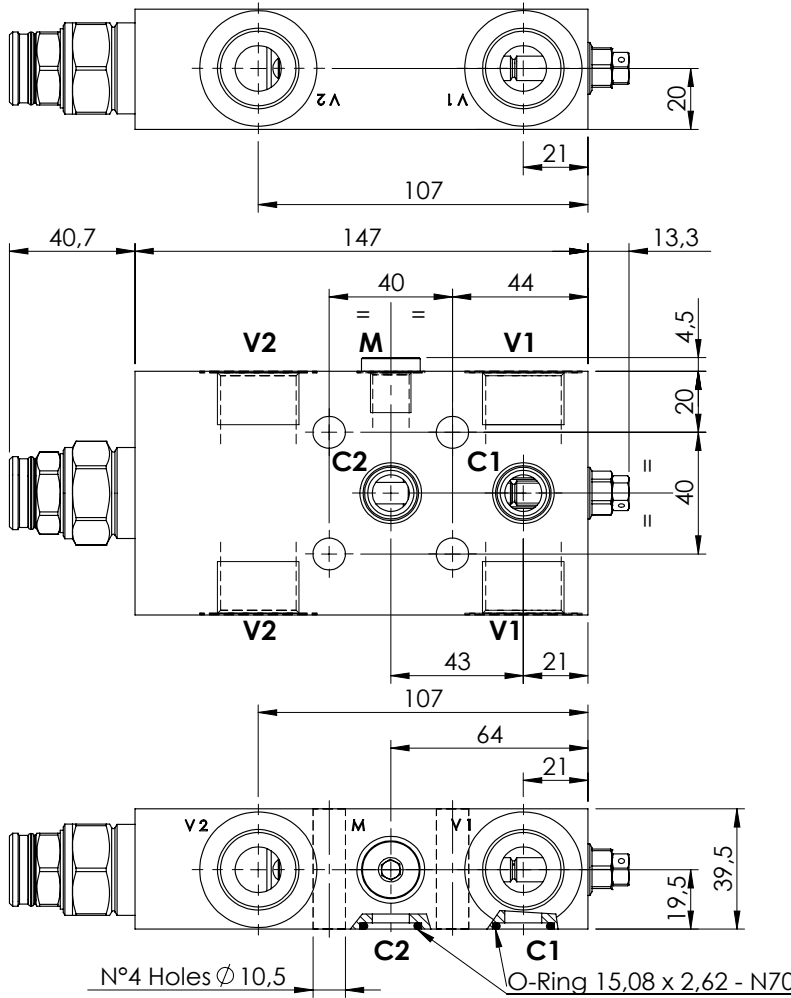

SPECIFICATIONS

Max. operating pressure:	350 bar
Rated flow:	150 l/min
Manifold:	Steel
Weight:	3,12 kg

SEALING CAP

Ordering code:
ST000012



NOTES

Setting: at least 1.3 times the load induced pressure

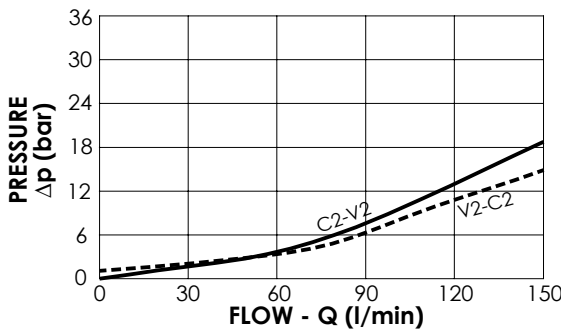

ORDERING CODES

Quick code	Description	Pilot ratio	Main ports size	Standard setting (bar, Q=5 l/min)	Adjust. range (bar)	Pressure increase (bar/turn)
MB000561	MBST-150-ABNV-04-G34-N350	4:1	V1, V2: G3/4" M: G 1/4" C1, C2: $\varnothing 12$	350	100-350	104

OVERCENTRE VALVE

MBDN-040-ALNP

DOUBLE ACTING

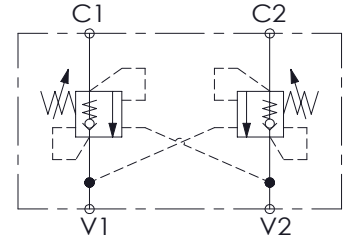
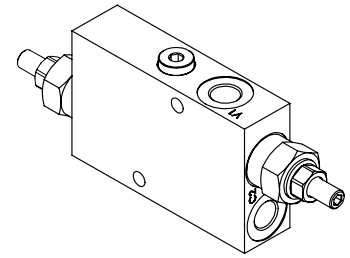
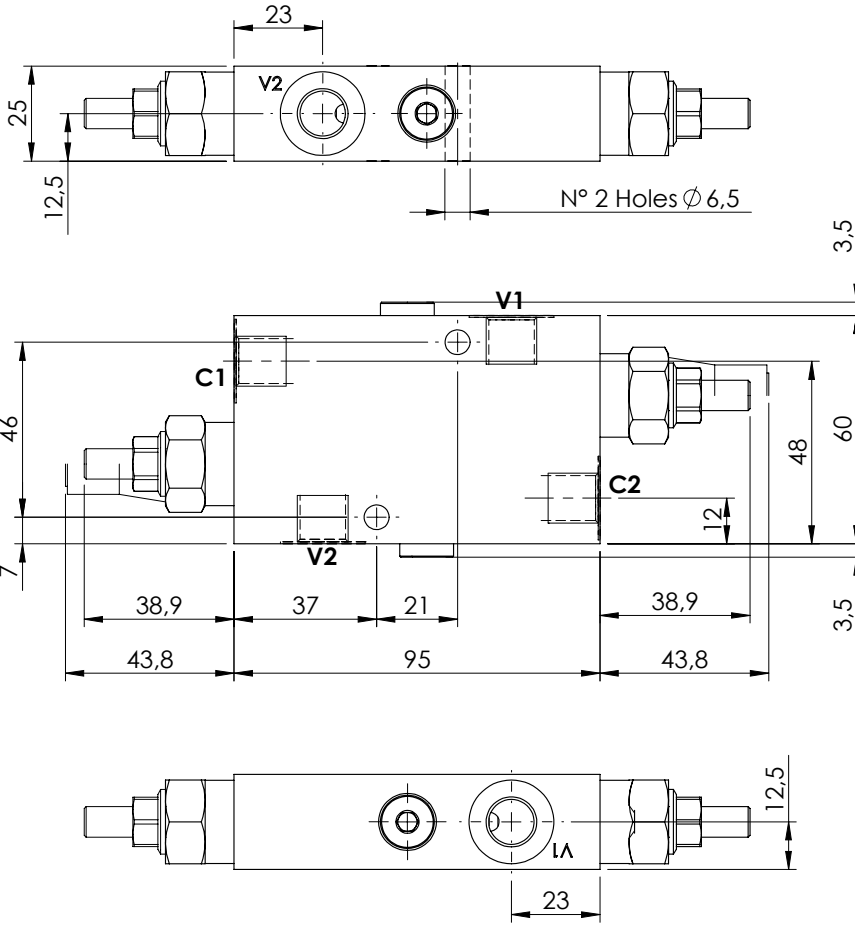

SPECIFICATIONS

Max. operating pressure:	350 bar
Rated flow:	40 l/min
Manifold:	Steel
Weight:	1,11 kg

SEALING CAP

Ordering code:
AT000020



NOTES

Setting: at least 1.3 times the load induced pressure

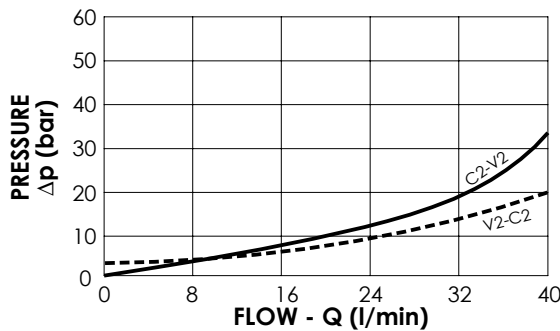

ORDERING CODES

Quick code	Description	Pilot ratio	Main ports size	Standard setting (bar, Q=5 l/min)	Adjust. range (bar)	Pressure increase (bar/turn)
MB000219	MBDN-040-ALNP-04-G14-N350	4,1:1	V1, V2: G1/4" C1, C2: G1/4"	350	100-350	184

OVERCENTRE VALVE

MBDN-040-ALNR

DOUBLE ACTING

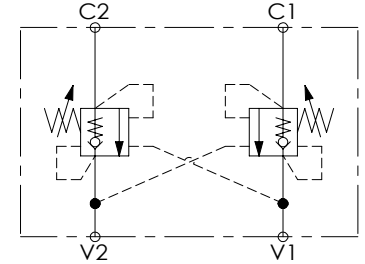
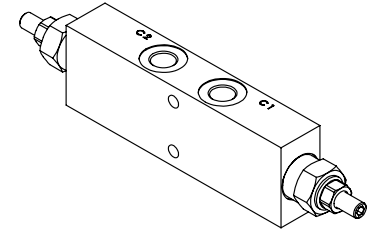
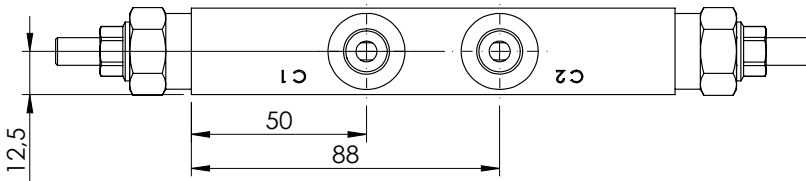
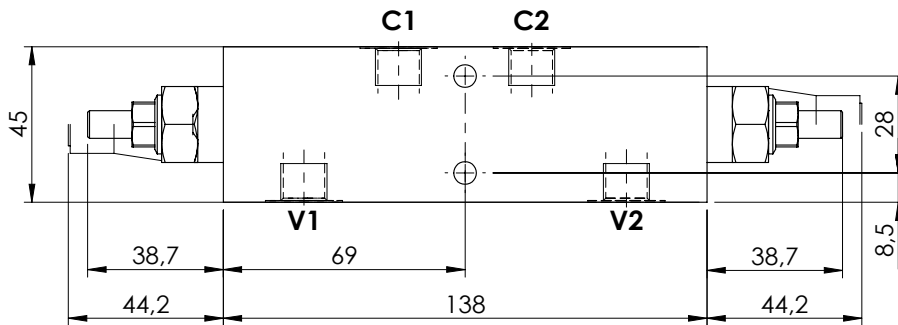
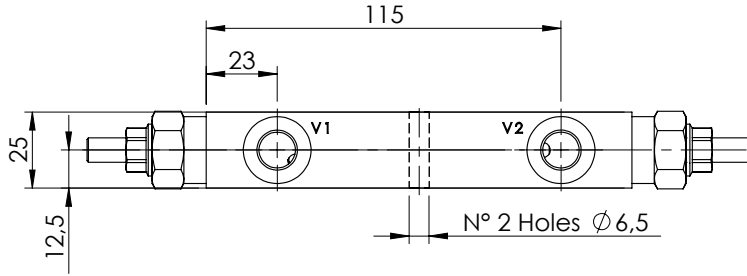

SPECIFICATIONS

Max. operating pressure:	350 bar
Rated flow:	40 l/min
Manifold:	Steel
Weight:	1,22 kg

SEALING CAP

Ordering code:
AT000020

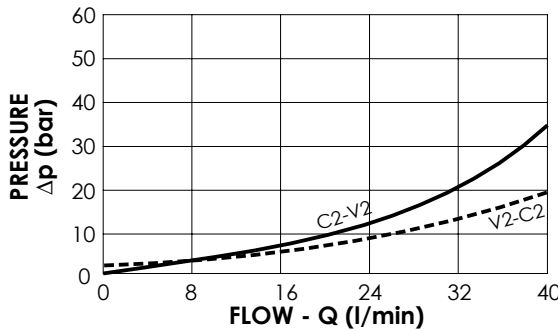
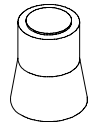

NOTES

Setting: at least 1.3 times the load induced pressure

ORDERING CODES

Quick code	Description	Pilot ratio	Main ports size	Standard setting (bar, Q=5 l/min)	Adjust. range (bar)	Pressure increase (bar/turn)
MB000072	MBDN-040-ALNR-04-G14-N350	4,1:1	V1, V2: G1/4" C1, C2: G1/4"	350	100-350	184
MB000873	MBDN-040-ALNR-04-G14-N200	4,1:1	V1, V2: G1/4" C1, C2: G1/4"	200	60-210	83
MB000381	MBDN-040-ALNR-07-G14-N350	7,5:1	V1, V2: G1/4" C1, C2: G1/4"	350	100-350	138

OVERCENTRE VALVE

MBDN-040-ZLNN

DOUBLE ACTING

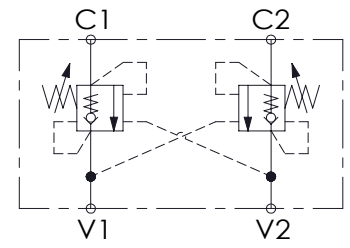
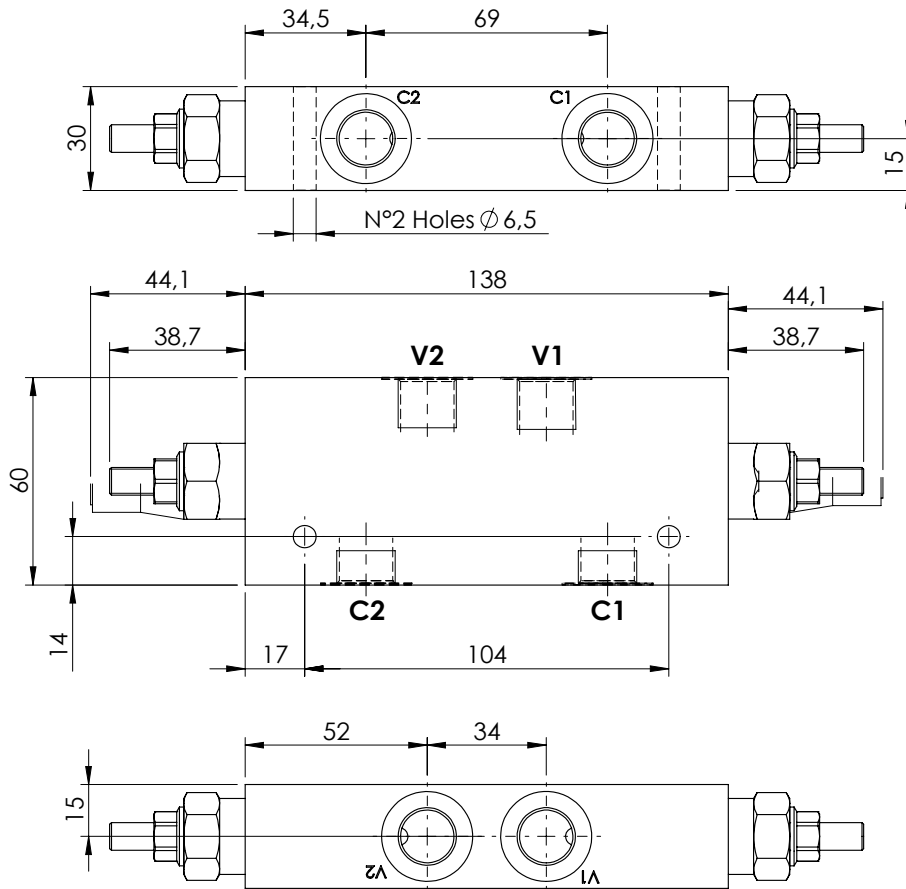
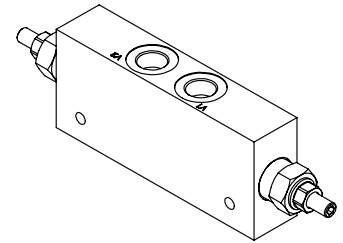

SPECIFICATIONS

Max. operating pressure:	350 bar
Rated flow:	40 l/min
Manifold:	Aluminium
Weight:	0,78 kg

SEALING CAP

Ordering code:
AT000020

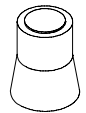

NOTES

Setting: at least 1.3 times the load induced pressure

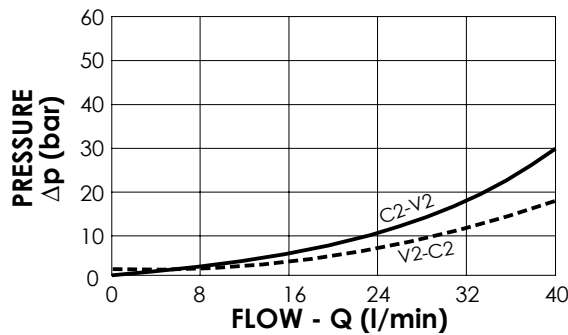

ORDERING CODES

Quick code	Description	Pilot ratio	Main ports size	Standard setting (bar, Q=5 l/min)	Adjust. range (bar)	Pressure increase (bar/turn)
MB000310	MBDN-040-ZLNN-04-G38-N350	4,1:1	V1,V2: G 3/8" C1,C2: G 3/8"	350	100-350	184
MB000311	MBDN-040-ZLNN-04-G38-N200	4,1:1	V1,V2: G 3/8" C1,C2: G 3/8"	200	60-210	83
MB000312	MBDN-040-ZLNN-04-G38-N100	4,1:1	V1,V2: G 3/8" C1,C2: G 3/8"	100	45-100	45
MB000341	MBDN-040-ZLNN-07-G38-N350	7,5:1	V1,V2: G 3/8" C1,C2: G 3/8"	350	100-350	138
MB000409	MBDN-040-ZLNN-07-G38-N200	7,5:1	V1,V2: G 3/8" C1,C2: G 3/8"	200	60-210	80

OVERCENTRE VALVE

MBDN-040-AANR

**DOUBLE ACTING
ONE FLANGED PORT**

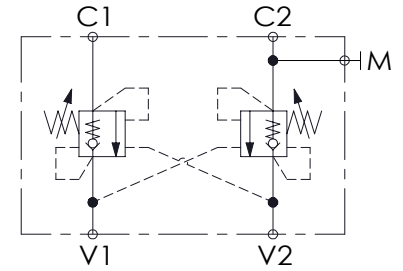
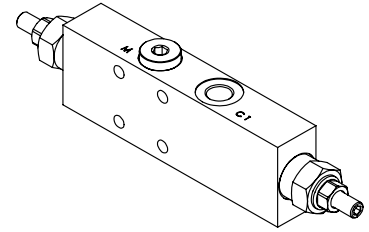
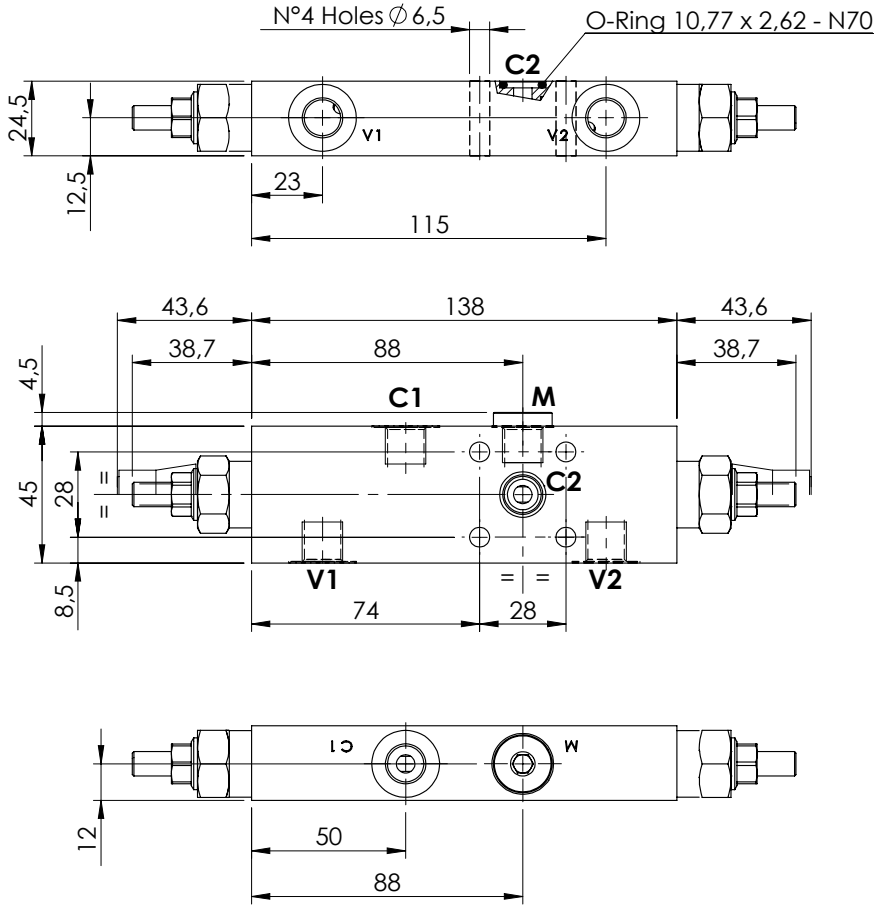

SPECIFICATIONS

Max. operating pressure:	350 bar
Rated flow:	40 l/min
Manifold:	Steel
Weight:	1,2 kg

SEALING CAP

Ordering code:
AT000020

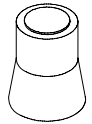

NOTES

Setting: at least 1.3 times the load induced pressure

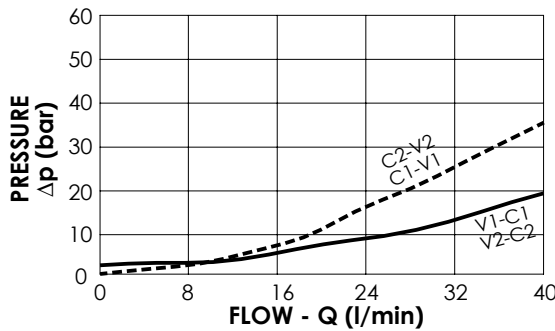

ORDERING CODES

Quick code	Description	Pilot ratio	Main ports size	Standard setting (bar, Q=5 l/min)	Adjust. range (bar)	Pressure increase (bar/turn)
MB000106	MBDN-040-AANR-04-G14-N350	4,1:1	V1, V2: G1/4" C1: G1/4" C2:Ø6	350	100-350	184
MB000583	MBDN-040-AANR-07-G14-N350	7,5:1	V1, V2: G1/4" C1: G1/4" C2:Ø6	350	100-350	138

OVERCENTRE VALVE

MBDN-040-ABNP

DOUBLE ACTING
TWO FLANGED PORTS

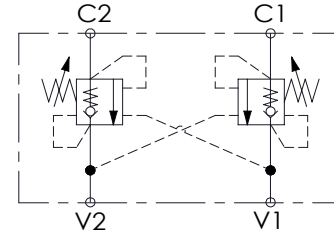
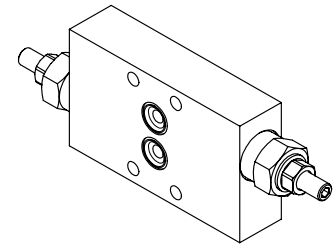
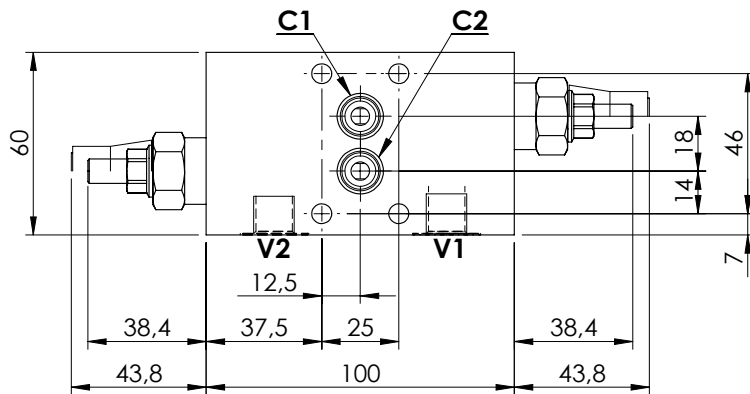
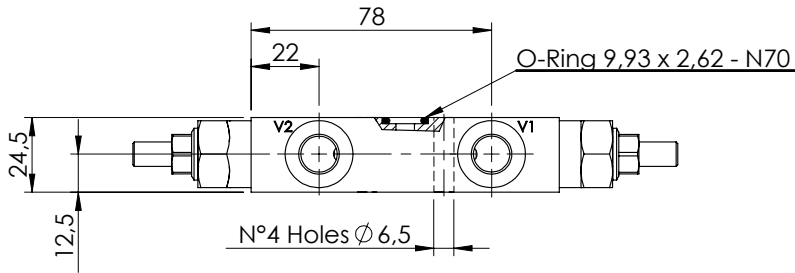

SPECIFICATIONS

Max. operating pressure:	350 bar
Rated flow:	40 l/min
Manifold:	Steel
Weight:	1,15 kg

SEALING CAP

Ordering code:
AT000020

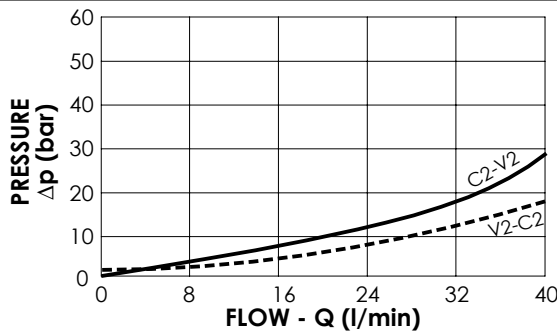
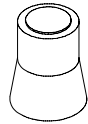

NOTES

Setting: at least 1.3 times the load induced pressure

ORDERING CODES

Quick code	Description	Pilot ratio	Main ports size	Standard setting (bar, Q=5 l/min)	Adjust. range (bar)	Pressure increase (bar/turn)
MB000334	MBDN-040-ABNP-04-G14-N350	4,1:1	V1, V2: G1/4" C1, C2: \varnothing 6	350	100-350	184

OVERCENTRE VALVE

MBDN-040-ABNR

DOUBLE ACTING
TWO FLANGED PORTS

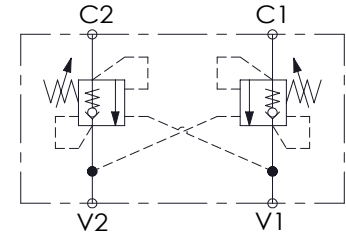
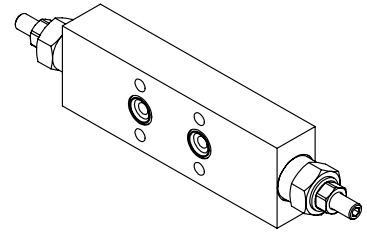
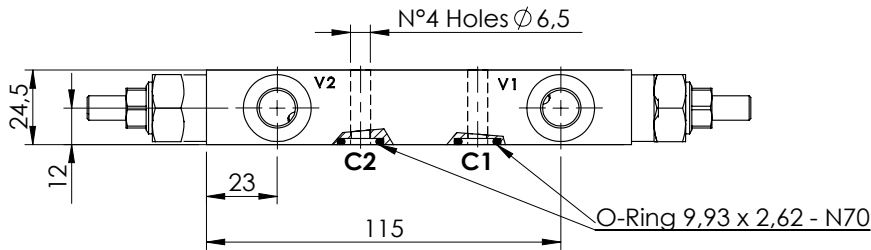
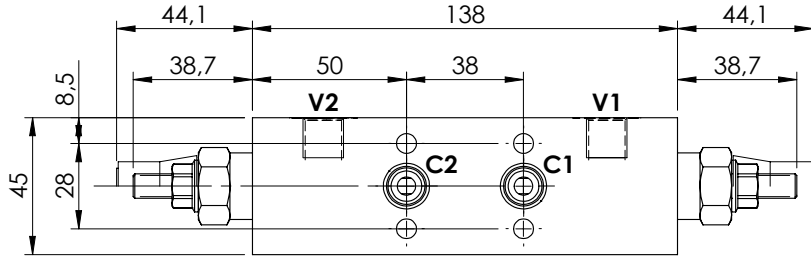

SPECIFICATIONS

Max. operating pressure:	350 bar
Rated flow:	40 l/min
Manifold:	Steel
Weight:	1,21 kg

SEALING CAP

Ordering code:
AT000020

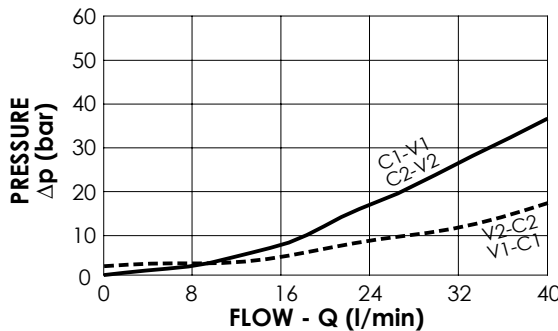
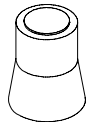

NOTES

Setting: at least 1.3 times the load induced pressure

ORDERING CODES

Quick code	Description	Pilot ratio	Main ports size	Standard setting (bar, Q=5 l/min)	Adjust. range (bar)	Pressure increase (bar/turn)
MB000110	MBDN-040-ABNR-04-G14-N350	4,1:1	V1, V2: G1/4" C1, C2: Ø6	350	100-350	184
MB000331	MBDN-040-ABNR-07-G14-N350	7,5:1	V1, V2: G1/4" C1, C2: Ø6	350	100-350	138
MB000589	MBDN-040-ABNR-11-G14-N350	11,5:1	V1, V2: G1/4" C1, C2: Ø6	350	100-350	228

OVERCENTRE VALVE

MBDN-040-ABNV DOUBLE ACTING
TWO FLANGED PORTS

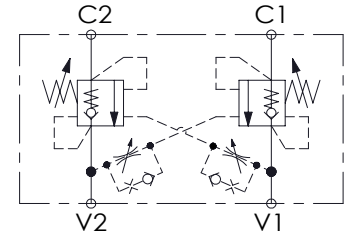
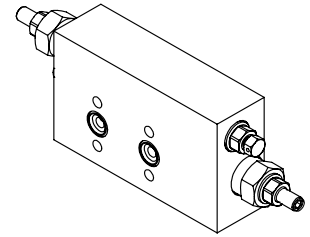
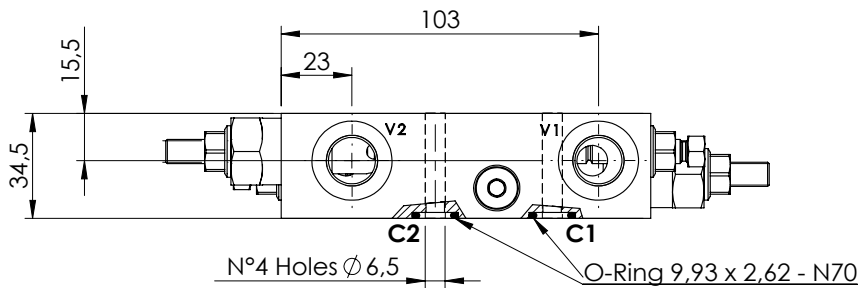
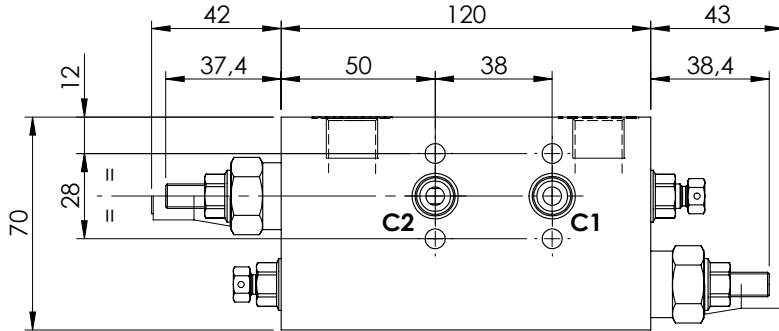

SPECIFICATIONS

Max. operating pressure:	350 bar
Rated flow:	40 l/min
Manifold:	Steel
Weight:	2,19 kg

SEALING CAP

Ordering code:
AT000020

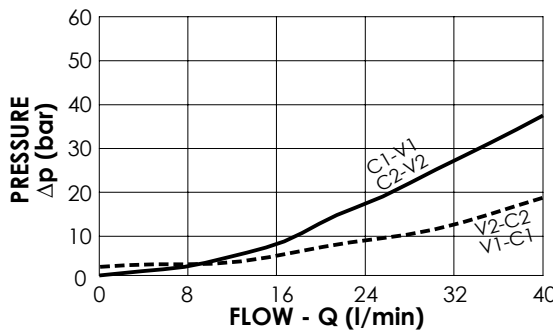
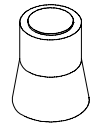

NOTES

Setting: at least 1.3 times the load induced pressure

ORDERING CODES

Quick code	Description	Pilot ratio	Main ports size	Standard setting (bar, Q=5 l/min)	Adjust. range (bar)	Pressure increase (bar/turn)
MB000590	MBDN-040-ABNV-04-G38-N350	4,1:1	V1, V2: G3/8" C1, C2: Ø6	350	100-350	184

OVERCENTRE VALVE

MBDN-040-LBNN

**DOUBLE ACTING
TWO FLANGED PORTS**

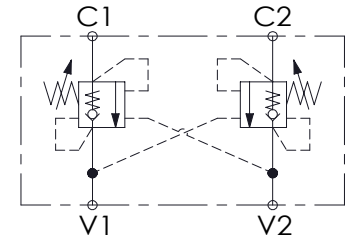
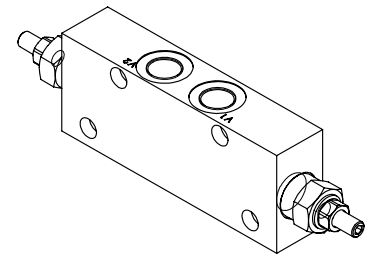
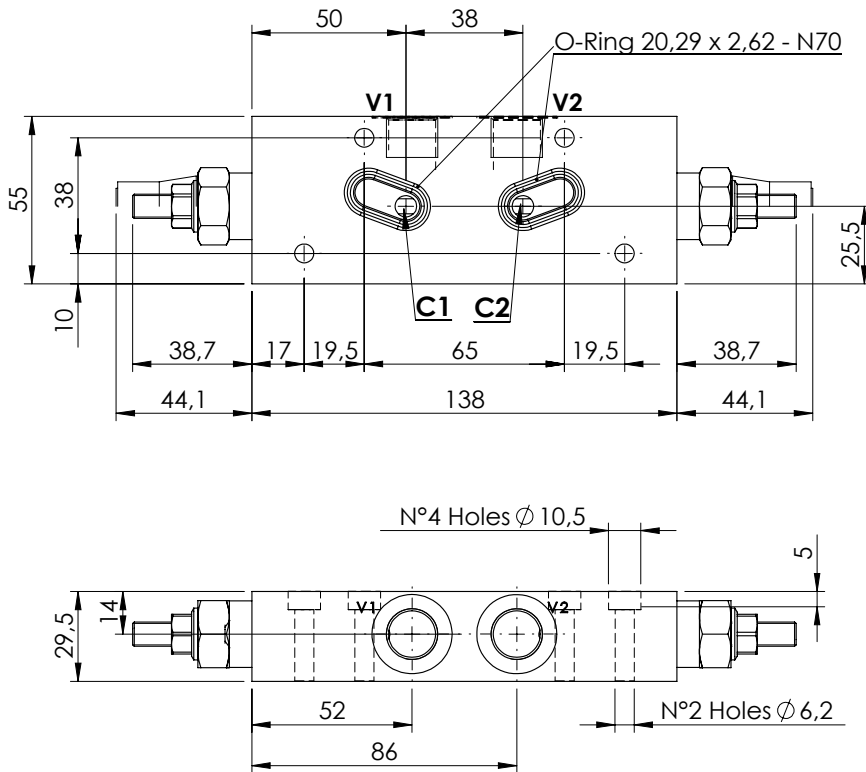

SPECIFICATIONS

Max. operating pressure:	350 bar
Rated flow:	40 l/min
Manifold:	Aluminium
Weight:	0,72 kg

SEALING CAP

Ordering code:
AT000020

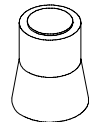

NOTES

Setting: at least 1.3 times the load induced pressure

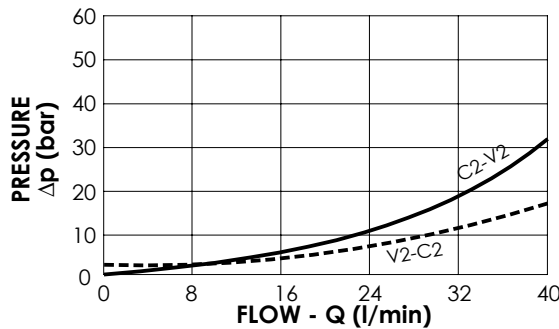

ORDERING CODES

Quick code	Description	Pilot ratio	Main ports size	Standard setting (bar, Q=5 l/min)	Adjust. range (bar)	Pressure increase (bar/turn)
MB000410	MBDN-040-ZBNN-04-G38-N350	4,1:1	V1,V2: G3/8" C1,C2: Ø 7	350	100-350	184
MB000411	MBDN-040-LBNN-04-G38-N200	4,1:1	V1,V2: G3/8" C1,C2: Ø 7	200	60-210	83
MB000412	MBDN-040-LBNN-07-G38-N350	7,5:1	V1,V2: G3/8" C1,C2: Ø 7	350	100-350	138
MB000413	MBDN-040-LBNN-07-G38-N200	7,5:1	V1,V2: G3/8" C1,C2: Ø 7	200	60-210	80

OVERCENTRE VALVE

MBDN-040-ZDNA

**DOUBLE ACTING
ALL FLANGED PORTS**

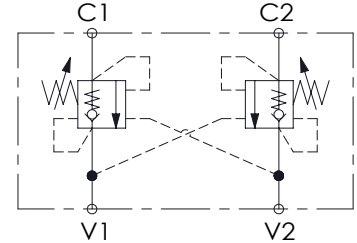
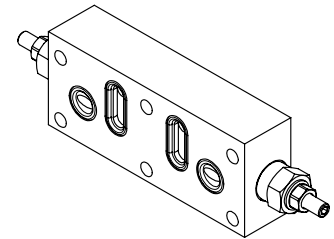
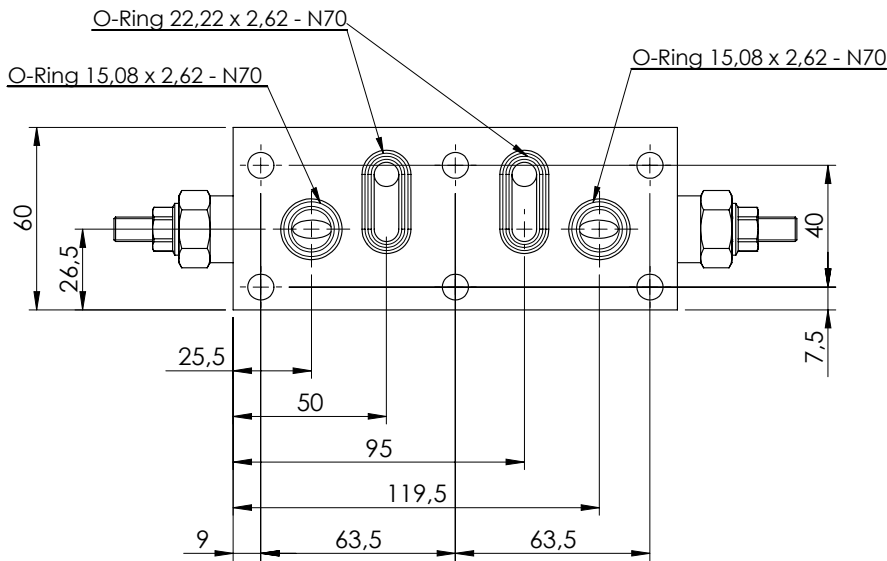
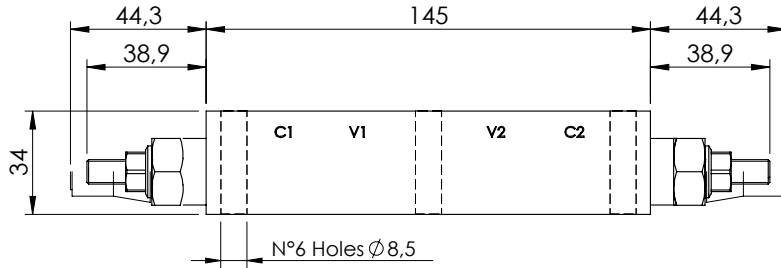

SPECIFICATIONS

Max. operating pressure:	350 bar
Rated flow:	40 l/min
Weight:	0.9 kg

SEALING CAP

Ordering code:
AT000020

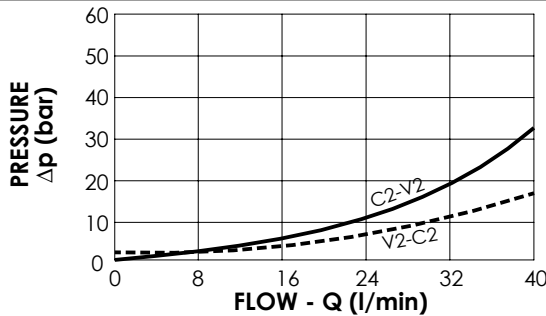
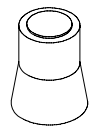

NOTES

Setting: at least 1.3 times the load induced pressure

ORDERING CODES

Quick code	Description	Pilot ratio	Manifold material	Main ports size	Standard setting (bar, Q=5 l/min)	Adjust. range (bar)	Pressure increase (bar/turn)
MB000523	MBDN-040-ZDNA-04-PTF-N350	4,1:1	Aluminium	V1,V2: Ø8 C1,C2: Ø8	350	100-350	184
MB000524	MBDN-040-ZDNA-04-PTF-N200	4,1:1	Aluminium	V1,V2: Ø8 C1,C2: Ø8	200	60-210	83

OVERCENTRE VALVE

MBDN-060-ALNR DOUBLE ACTING

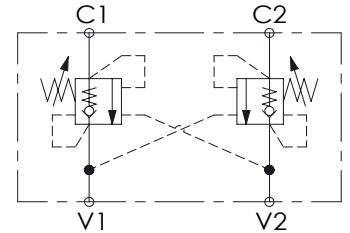
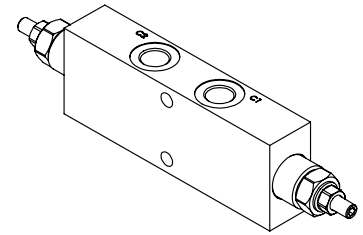
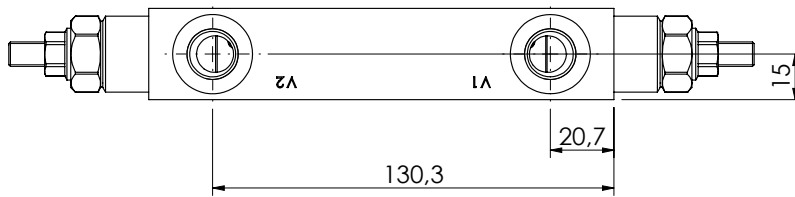
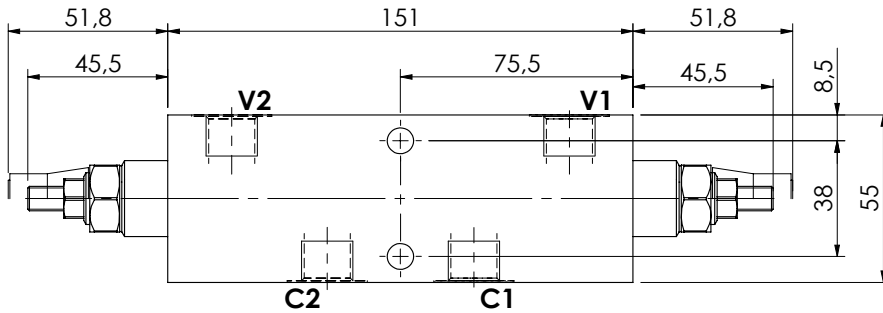
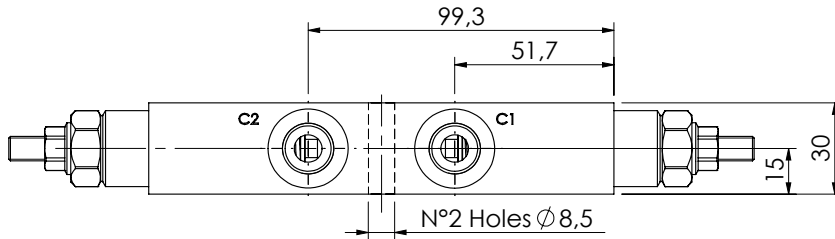

SPECIFICATIONS

Max. operating pressure:	350 bar
Rated flow:	60 l/min
Manifold:	Steel
Weight:	1,92 kg

SEALING CAP

Ordering code:
AT000020

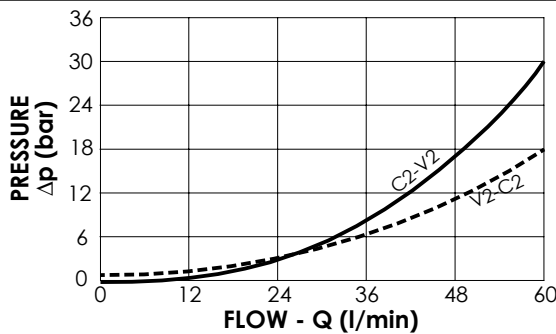
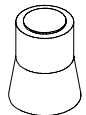

NOTES

Setting: at least 1.3 times the load induced pressure

ORDERING CODES

Quick code	Description	Pilot ratio	Main ports size	Standard setting (bar, Q=5 l/min)	Adjust. range (bar)	Pressure increase (bar/turn)
MB000006	MBDN-060-ALNR-04-G38-N350	4,2:1	V1, V2: G3/8" C1, C2: G3/8"	350	100-350	138
MB000084	MBDN-060-ALNR-04-G38-N200	4,2:1	V1, V2: G3/8" C1, C2: G3/8"	200	60-210	62
MB000186	MBDN-060-ALNR-11-G38-N250	11:1	V1, V2: G3/8" C1, C2: G3/8"	250	60-250	69

OVERCENTRE VALVE

MBDN-060-ALNR

DOUBLE ACTING

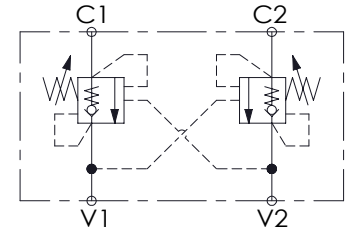
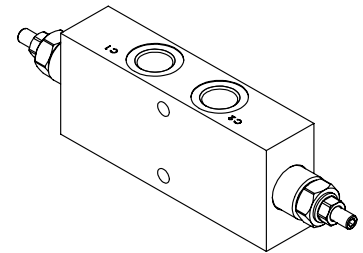
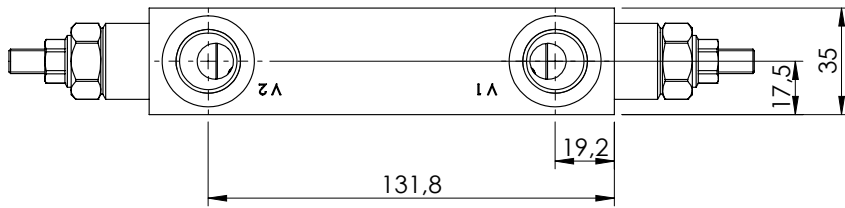
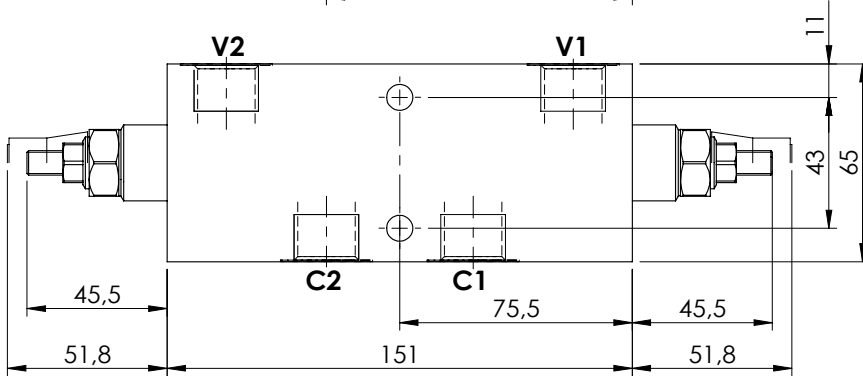
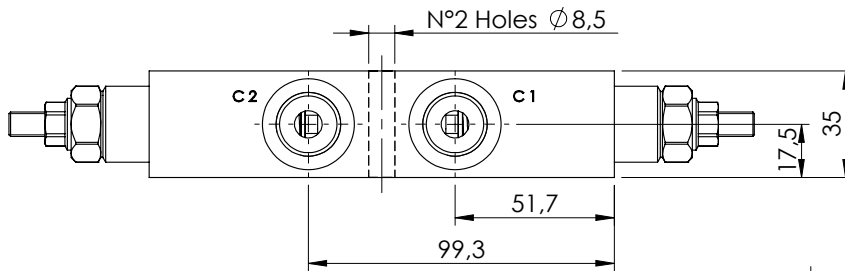

SPECIFICATIONS

Max. operating pressure:	350 bar
Rated flow:	60 l/min
Manifold:	Steel
Weight:	2,56 kg

SEALING CAP

Ordering code:
AT000020

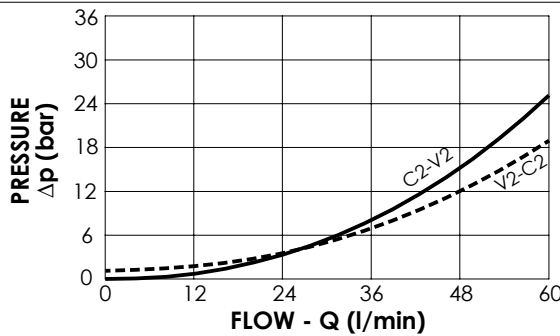
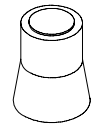

NOTES

Setting: at least 1.3 times the load induced pressure

ORDERING CODES

Quick code	Description	Pilot ratio	Main ports size	Standard setting (bar, Q=5 l/min)	Adjust. range (bar)	Pressure increase (bar/turn)
MB000009	MBDN-060-ALNR-04-G12-N350	4,2:1	V1, V2: G1/2" C1, C2: G1/2"	350	100-350	138
MB000263	MBDN-060-ALNR-04-G12-N200	4,2:1	V1, V2: G1/2" C1, C2: G1/2"	200	60-210	62
MB000391	MBDN-060-ALNR-11-G12-N350	11:1	V1, V2: G1/2" C1, C2: G1/2"	350	60-350	69

OVERCENTRE VALVE

MBDN-060-ZLDE

DOUBLE ACTING

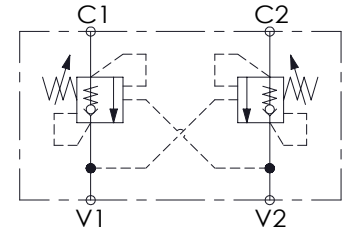
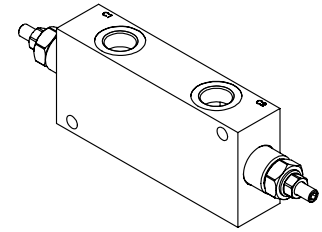
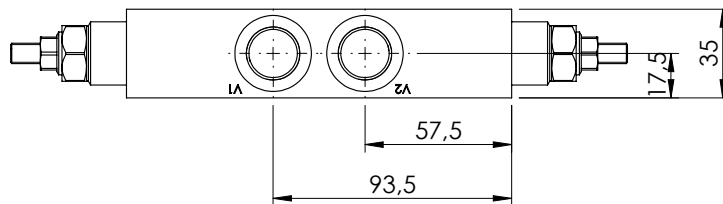
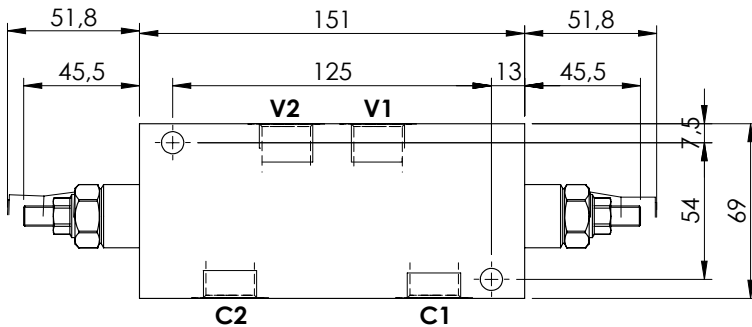
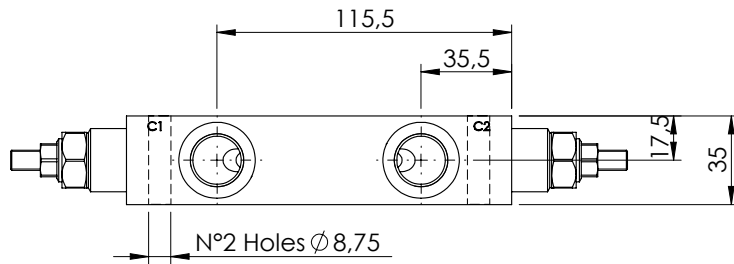

SPECIFICATIONS

Max. operating pressure: 350 bar

Rated flow: 60 l/min

Weight: Aluminium 1.1 kg; Steel 2.7 kg

SEALING CAP

Ordering code:

AT000020

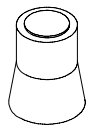

NOTES

Setting: at least 1.3 times the load induced pressure

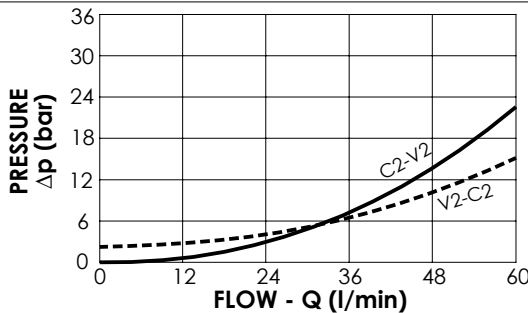

ORDERING CODES

Quick code	Description	Pilot ratio	Manifold material	Main ports size	Standard setting (bar, Q=5 l/min)	Adjust. range (bar)	Pressure increase (bar/turn)
MB000321	MBDN-060-ZLDE-04-G12-N350	4.2:1	Aluminium	V1, V2: G1/2" C1, C2: G1/2"	350	100-350	138
MB000443	MBDN-060-ZLDE-04-G12-N200	4.2:1	Aluminium	V1, V2: G1/2" C1, C2: G1/2"	200	60-210	62
MB000444	MBDN-060-ALDE-04-G12-N350	4.2:1	Steel	V1, V2: G1/2" C1, C2: G1/2"	350	100-350	138
MB000445	MBDN-060-ALDE-04-G12-N200	4.2:1	Steel	V1, V2: G1/2" C1, C2: G1/2"	200	60-210	62
MB000320	MBDN-060-ZLDE-07-G12-N350	7:1	Aluminium	V1, V2: G1/2" C1, C2: G1/2"	350	100-350	106
MB000446	MBDN-060-ZLDE-07-G12-N200	7:1	Aluminium	V1, V2: G1/2" C1, C2: G1/2"	200	60-210	46
MB000447	MBDN-060-ALDE-07-G12-N350	7:1	Steel	V1, V2: G1/2" C1, C2: G1/2"	350	100-350	106
MB000448	MBDN-060-ALDE-07-G12-N200	7:1	Steel	V1, V2: G1/2" C1, C2: G1/2"	200	60-210	46

OVERCENTRE VALVE

MBDN-060-AANR

**DOUBLE ACTING
ONE FLANGED PORT**

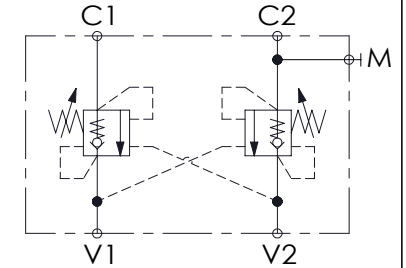
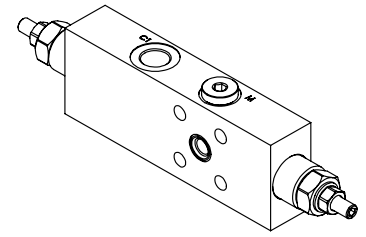
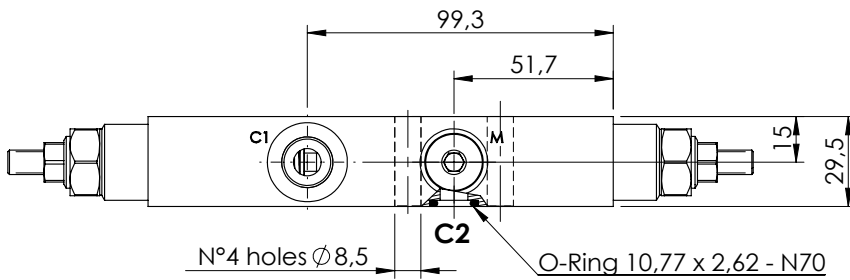
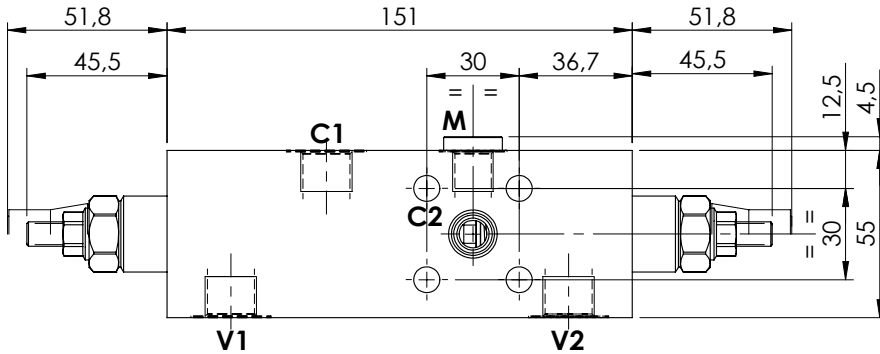
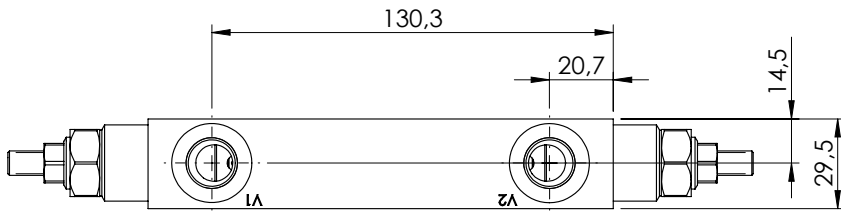

SPECIFICATIONS

Max. operating pressure:	350 bar
Rated flow:	60 l/min
Manifold:	Steel
Weight:	1,88 kg

SEALING CAP

Ordering code:
AT000020

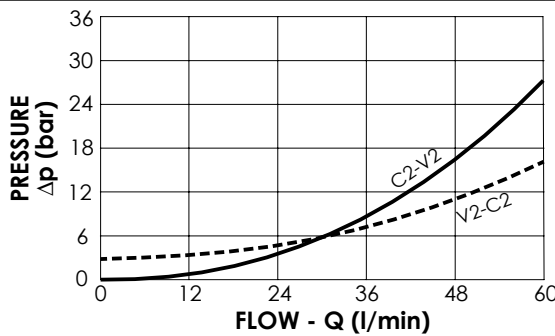
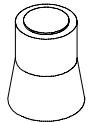

NOTES

Setting: at least 1.3 times the load induced pressure

ORDERING CODES

Quick code	Description	Pilot ratio	Main ports size	Standard setting (bar, Q=5 l/min)	Adjust. range (bar)	Pressure increase (bar/turn)
MB000008	MBDN-060-AANR-04-G38-N350	4,2:1	V1, V2, C1: G3/8" C2: Ø9 M: G1/4"	350	100-350	138

OVERCENTRE VALVE

MBDN-060-ABNR

DOUBLE ACTING
TWO FLANGED PORTS

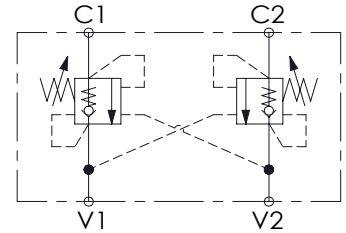
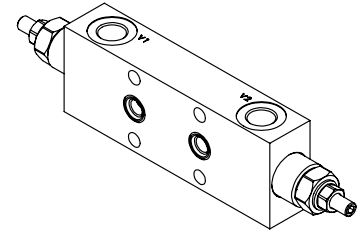
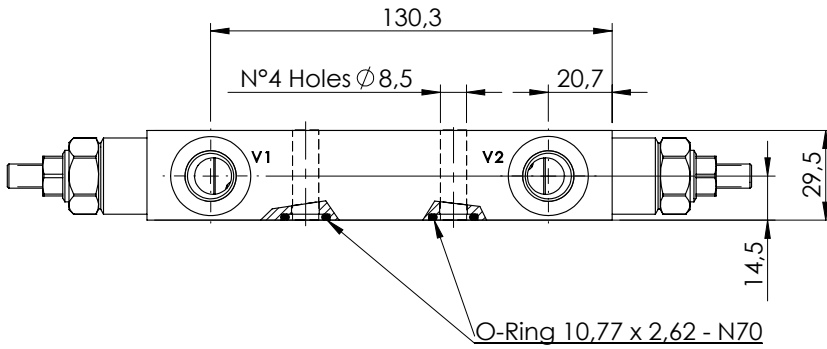
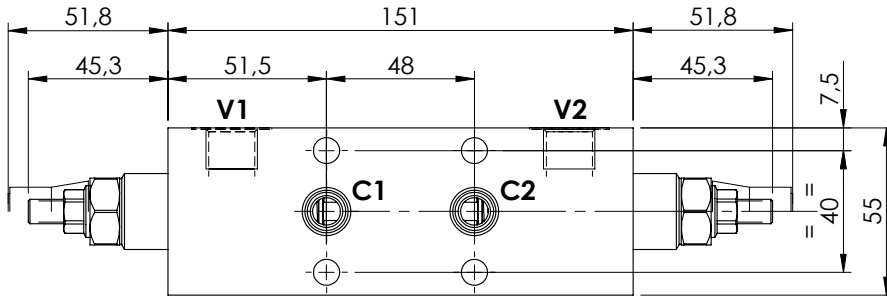

SPECIFICATIONS

Max. operating pressure:	350 bar
Rated flow:	60 l/min
Manifold:	Steel
Weight:	1,89 kg

SEALING CAP

Ordering code:
AT000020

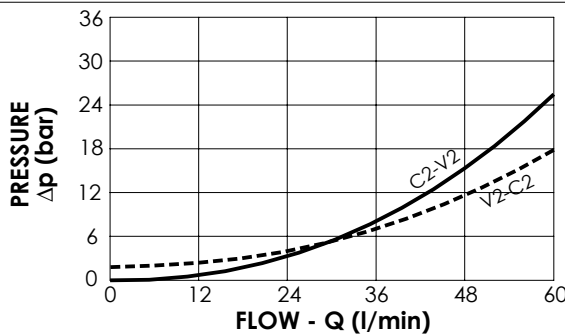
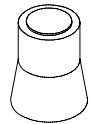

NOTES

Setting: at least 1.3 times the load induced pressure

ORDERING CODES

Quick code	Description	Pilot ratio	Main ports size	Standard setting (bar, Q=5 l/min)	Adjust. range (bar)	Pressure increase (bar/turn)
MB000235	MBDN-060-ABNR-11-G38-N250	11:1	V1, V2: G3/8" C1, C2: Ø9	200	60-250	69
MB000087	MBDN-060-ABNR-04-G38-N350	4,2:1	V1, V2: G3/8" C1, C2: Ø9	350	100-350	138
MB000178	MBDN-060-ABNR-04-G38-N200	4,2:1	V1, V2: G3/8" C1, C2: Ø9	200	60-210	62
MB000826	MBDN-060-ABNR-07-G38-N350	7:1	V1, V2: G3/8" C1, C2: Ø9	350	100-350	106

OVERCENTRE VALVE

MBDN-060-ABNR

DOUBLE ACTING,
TWO FLANGED PORTS

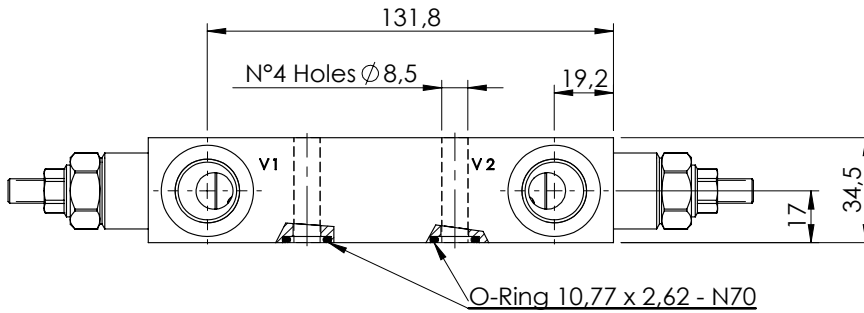
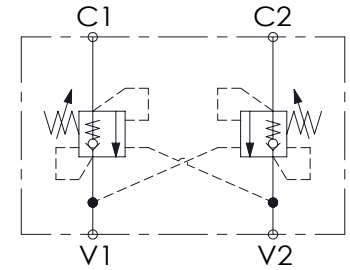
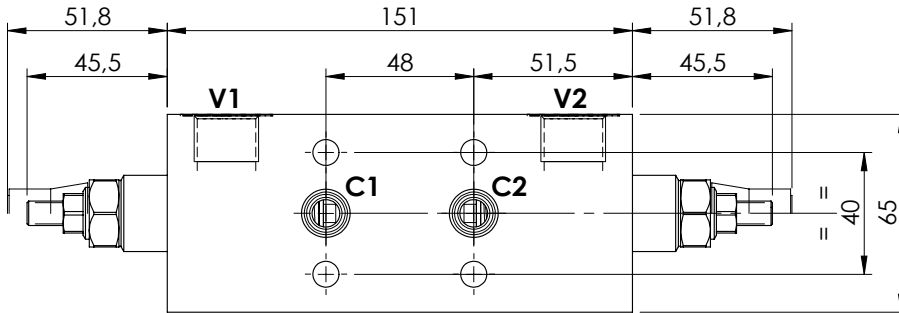
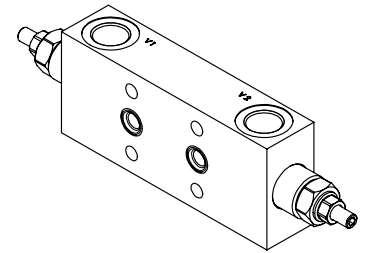

SPECIFICATIONS

Max operating pressure:	420 bar
Rated flow:	60 l/min
Manifold :	Steel
Weight:	2,57 kg

SEALING CAP

Ordering code:
AT000020

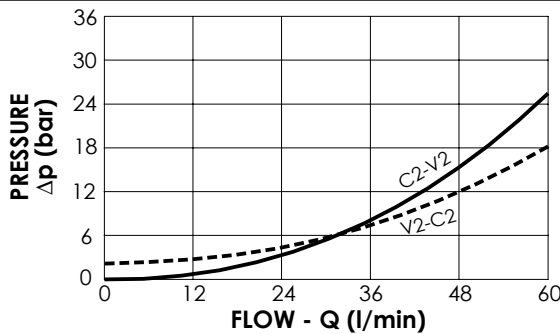
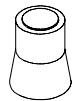

NOTES

Setting: at least 1.3 times the load induced pressure

ORDERING CODES

Quick code	Description	Pilot ratio	Main ports size	Standard setting (bar, Q=5 l/min)	Pressure range (bar)	Pressure increase (bar/turn)
MB000016	MBDN-060-ABNR-04-G12-N350	4,2:1	V1, V2: G1/2" C1, C2: Ø9	350	100-350	138
MB000228	MBDN-060-ABNR-04-G12-N200	4,2:1	V1, V2: G1/2" C1, C2: Ø9	200	60-210	62
MB000229	MBDN-060-ABNR-11-G12-N200	11:1	V1, V2: G1/2" C1, C2: Ø9	200	60-250	69
MB000380	MBDN-060-ABNR-11-G12-N350	11:1	V1, V2: G1/2" C1, C2: Ø9	350	150-420	161

OVERCENTRE VALVE

MBDN-060-ZDNA

**DOUBLE ACTING
ALL FLANGED PORTS**

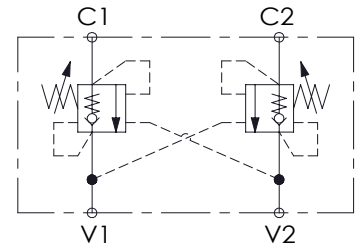
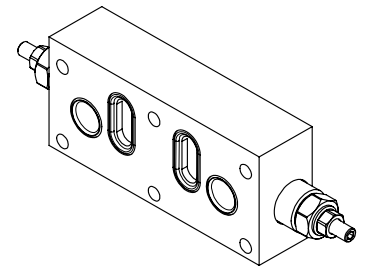
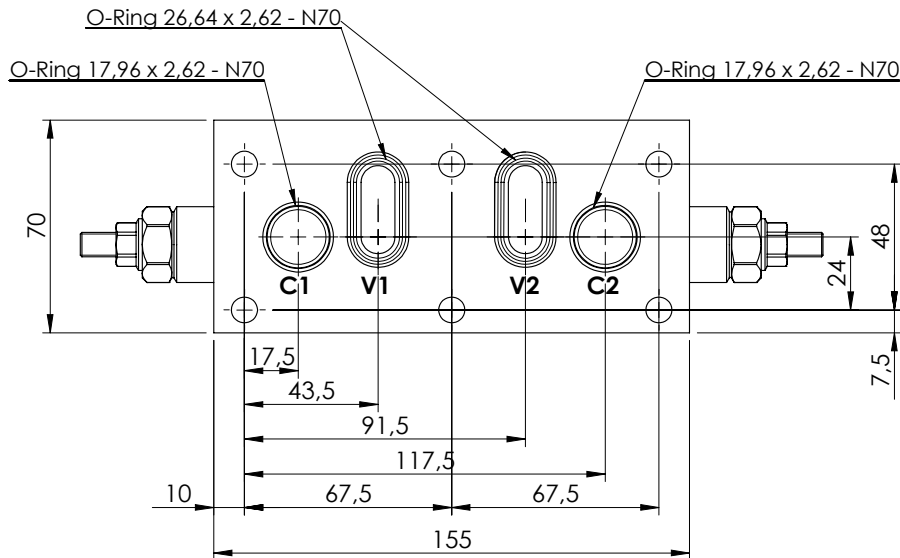
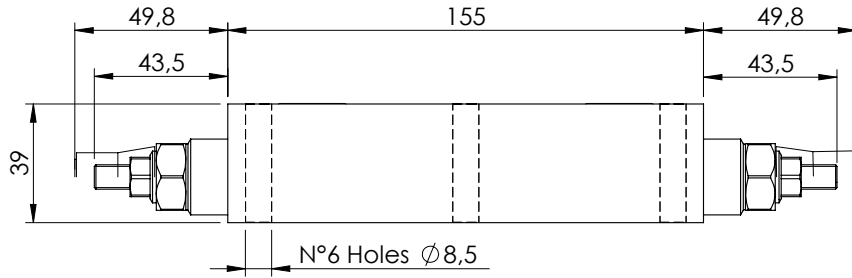

SPECIFICATIONS

Max. operating pressure:	350 bar
Rated flow:	60 l/min
Weight:	Aluminium 1.3kg, Steel 3.1kg

SEALING CAP

Ordering code:
AT000020

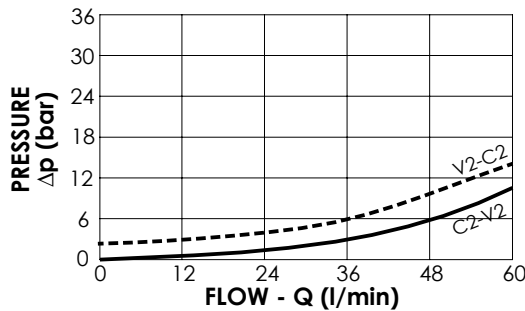
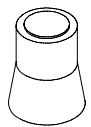

NOTES

Setting: at least 1.3 times the load induced pressure

ORDERING CODES

Quick code	Description	Pilot ratio	Manifold material	Main ports size	Standard setting (bar, Q=5 l/min)	Adjust. range (bar)	Pressure increase (bar/turn)
MB000404	MBDN-060-ZDNA-04-PTF-N350	4,2:1	Aluminium	V1,V2: Ø10 C1,C2: Ø10	350	100-350	138
MB000405	MBDN-060-ZDNA-04-PTF-N200	4,2:1	Aluminium	V1,V2: Ø10 C1,C2: Ø10	200	60-210	62
MB000424	MBDN-060-ADNA-04-PTF-N350	4,2:1	Steel	V1,V2: Ø10 C1,C2: Ø10	350	100-350	138
MB000442	MBDN-060-ADNA-04-PTF-N200	4,2:1	Steel	V1,V2: Ø10 C1,C2: Ø10	200	60-210	62
MB000399	MBDN-060-ZDNA-07-PTF-N350	7:1	Aluminium	V1,V2: Ø10 C1,C2: Ø10	350	100-350	106
MB000403	MBDN-060-ZDNA-07-PTF-N200	7:1	Aluminium	V1,V2: Ø10 C1,C2: Ø10	200	60-210	46
MB000441	MBDN-060-ADNA-07-PTF-N350	7:1	Steel	V1,V2: Ø10 C1,C2: Ø10	350	100-350	106
MB000440	MBDN-060-ADNA-07-PTF-N200	7:1	Steel	V1,V2: Ø10 C1,C2: Ø10	200	60-210	46

OVERCENTRE VALVE

MBDN-100-ALDE

DOUBLE ACTING

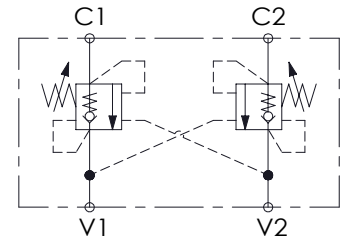
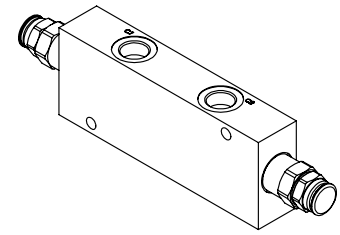
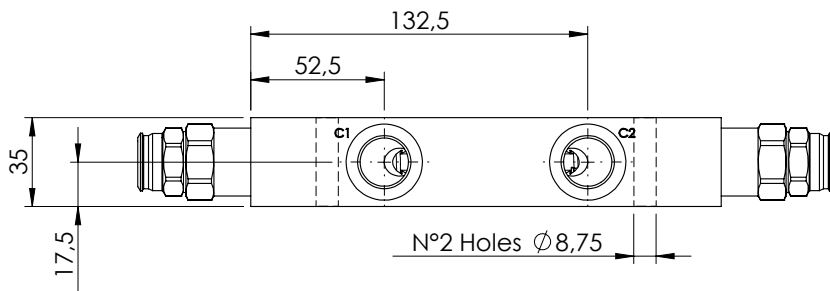
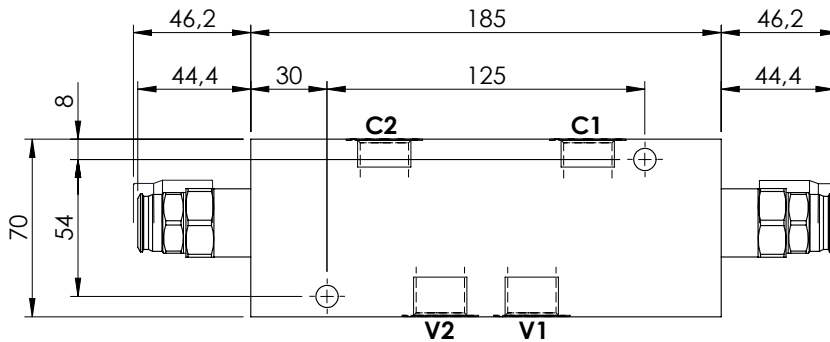
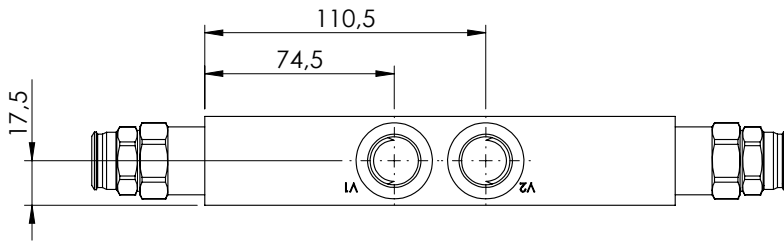

SPECIFICATIONS

Max. operating pressure:	350 bar
Rated flow:	100 l/min
Manifold:	Steel
Weight:	Steel 3,42 kg

SEALING CAP

Ordering code:
PT000243

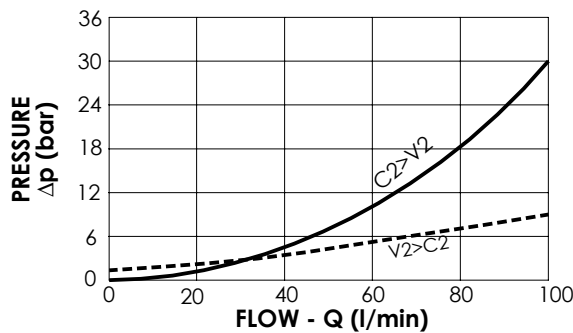
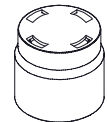

NOTES

Setting: at least 1.3 times the load induced pressure

ORDERING CODES

Quick code	Description	Pilot ratio	Main ports size	Manifold material	Standard setting (bar, Q=5 l/min)	Adjust. range (bar)	Pressur increase (bar/turn)
MB000398	MBDN-100-ALDE-04-G12-N350	4:1	V1,V2: G 1/2" C1,C2: G 1/2"	Steel	350	100-350	118
MB000400	MBDN-100-ALDE-04-G12-N200	4:1	V1,V2: G 1/2" C1,C2: G 1/2"	Steel	200	70-210	68
MB000395	MBDN-100-ALDE-08-G12-N350	8:1	V1,V2: G 1/2" C1,C2: G 1/2"	Steel	350	100-350	132
MB000401	MBDN-100-ALDE-08-G12-N200	8:1	V1,V2: G 1/2" C1,C2: G 1/2"	Steel	200	70-210	74

OVERCENTRE VALVE

MBDN-100-ABNR DOUBLE ACTING
TWO FLANGED PORTS

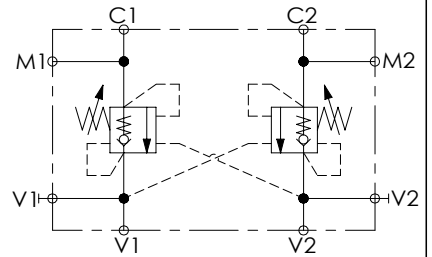
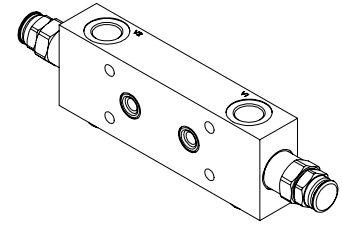
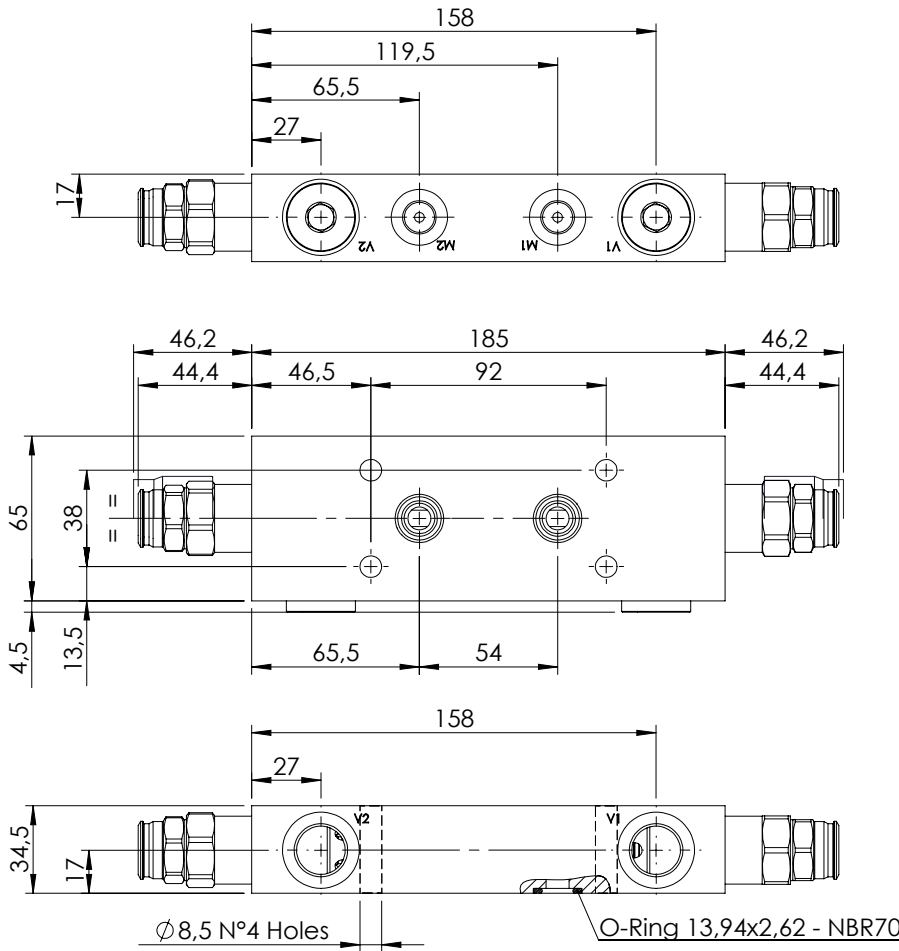

SPECIFICATIONS

Max. operating pressure:	350 bar
Rated flow:	100 l/min
Manifold:	Steel
Weight:	3,19 kg

SEALING CAP

Ordering code:
PT000243

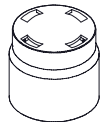

NOTES

Setting: at least 1.3 times the load induced pressure

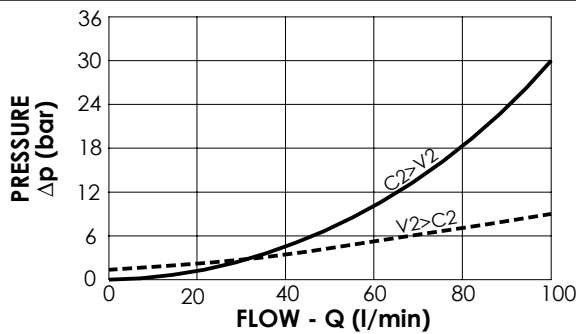

ORDERING CODES

Quick code	Description	Pilot ratio	Main ports size	Standard setting (bar, Q=5 l/min)	Adjust. range (bar)	Pressure increase (bar/turn)
MB000911	MBDN-100-ABNR-04-G12-N350	4:1	V1, V2: G 1/2" C1, C2: $\varnothing 9$ M1, M2: G 1/4"	350	100-350	118

OVERCENTRE VALVE

MBDN-150-ZLDE

DOUBLE ACTING

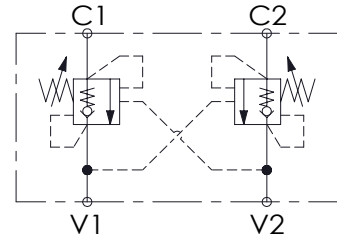
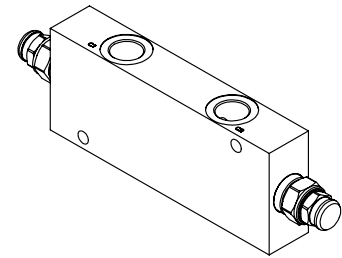
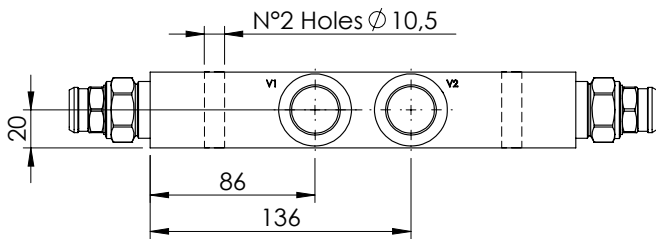
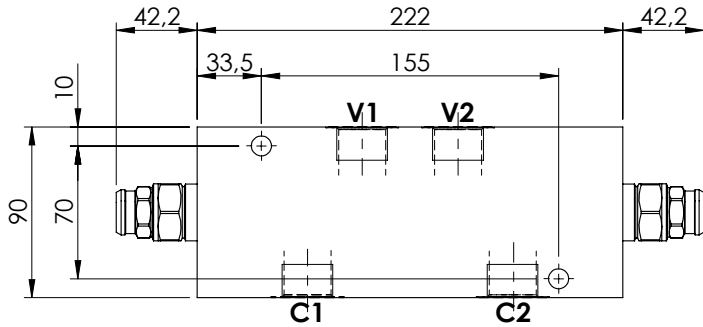
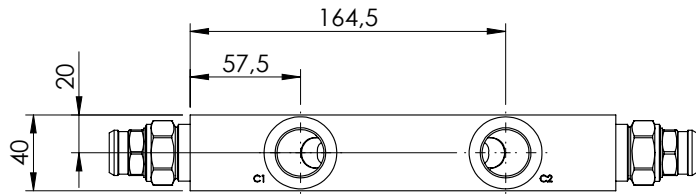

SPECIFICATIONS

Max. operating pressure:	350 bar
Rated flow:	150 l/min
Weight:	Aluminium 2,4 kg; Steel 5.7 kg

SEALING CAP

Ordering code:
ST000012

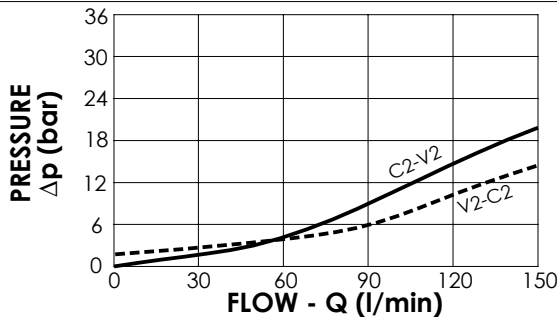
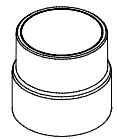

NOTES

Setting: at least 1.3 times the load induced pressure

ORDERING CODES

Quick code	Description	Pilot ratio	Manifold material	Main ports size	Standard setting (bar, Q=5 l/min)	Adjust. range (bar)	Pressure increase (bar/turn)
MB000414	MBDN-150-ZLDE-04-G34-N350	4:1	Aluminium	V1, V2: G3/4" C1, C2: G3/4"	350	100-350	104
MB000415	MBDN-150-ZLDE-04-G34-N200	4:1	Aluminium	V1, V2: G3/4" C1, C2: G3/4"	200	60-210	56
MB000407	MBDN-150-ZLDE-08-G34-N350	8:1	Aluminium	V1, V2: G3/4" C1, C2: G3/4"	350	100-350	82
MB000408	MBDN-150-ZLDE-08-G34-N200	8:1	Aluminium	V1, V2: G3/4" C1, C2: G3/4"	200	60-210	47
MB000420	MBDN-150-ALDE-04-G34-N350	4:1	Steel	V1, V2: G3/4" C1, C2: G3/4"	350	100-350	104
MB000421	MBDN-150-ALDE-04-G34-N200	4:1	Steel	V1, V2: G3/4" C1, C2: G3/4"	200	60-210	56
MB000418	MBDN-150-ALDE-08-G34-N350	8:1	Steel	V1, V2: G3/4" C1, C2: G3/4"	350	100-350	82
MB000419	MBDN-150-ALDE-08-G34-N200	8:1	Steel	V1, V2: G3/4" C1, C2: G3/4"	200	60-210	47

OVERCENTRE VALVE

MBDN-150-ZLNP

DOUBLE ACTING

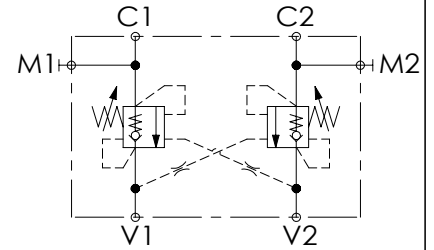
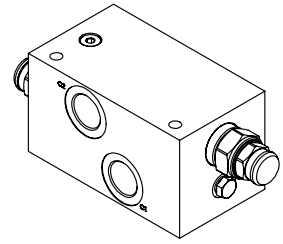
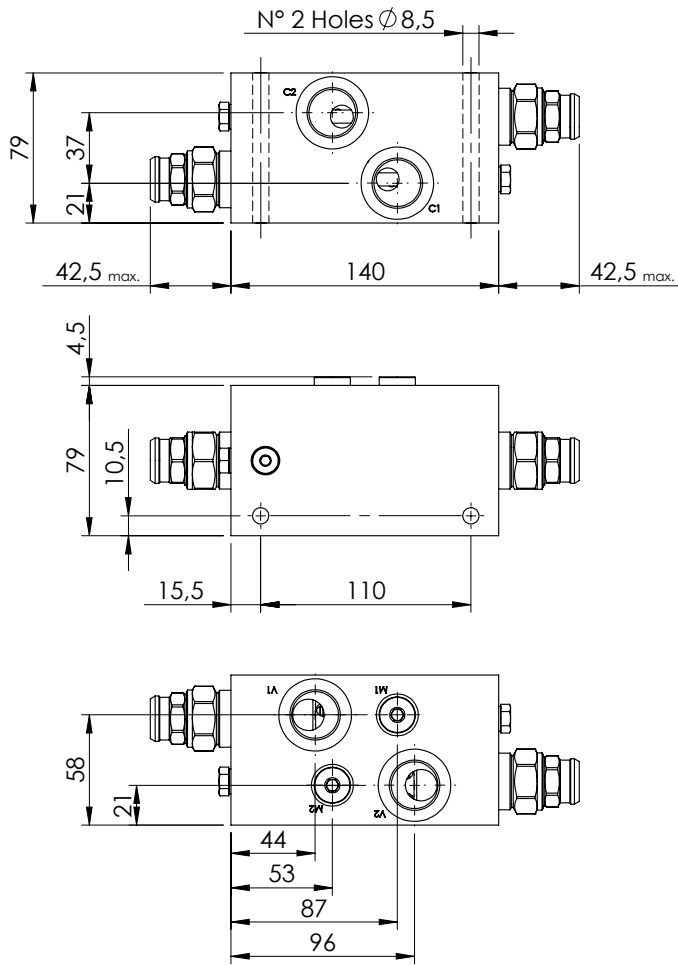

SPECIFICATIONS

Max. operating pressure:	350 bar
Rated flow:	150 l/min
Manifold:	Aluminium
Weight:	2,69 kg

SEALING CAP

Ordering code:
ST000012

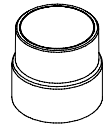

NOTES

Setting: at least 1.3 times the load induced pressure

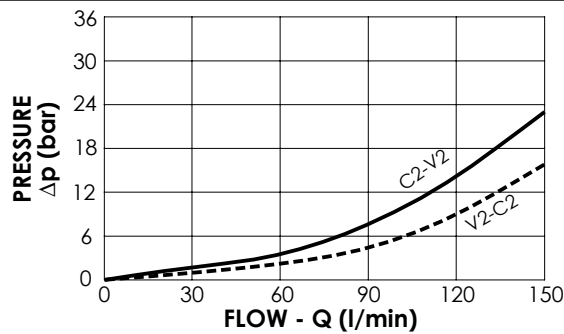

ORDERING CODES

Quick code	Description	Pilot ratio	Main ports size	Standard setting (bar, Q=5 l/min)	Adjust. range (bar)	Pressure increase (bar/turn)
MB000210	MBDN-150-ZLNP-04-G34-N350	4:1	V1, V2: G3/4" C1, C2: G3/4"	350	100-350	104

OVERCENTRE VALVE

MBDN-150-ZBNV

**DOUBLE ACTING
TWO FLANGED PORTS**

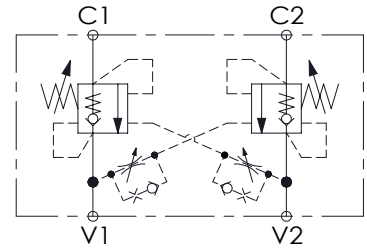
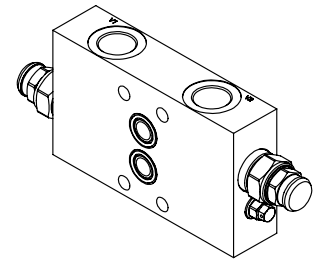
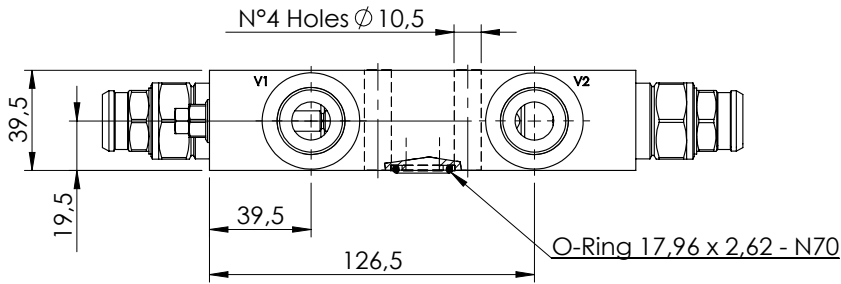
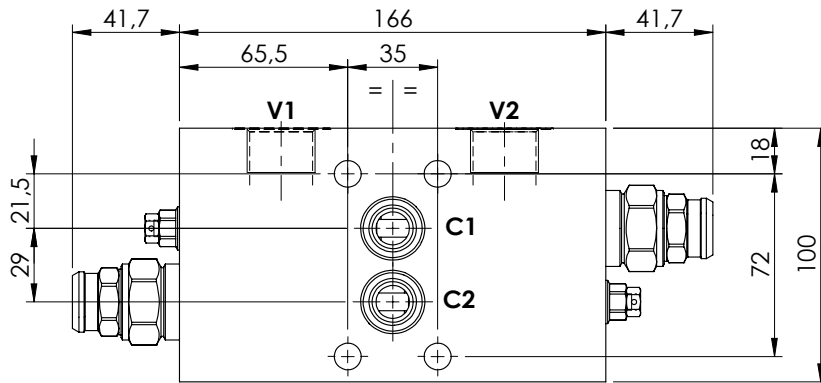

SPECIFICATIONS

Max. operating pressure:	350 bar
Rated flow:	150 l/min
Manifold:	Aluminium
Weight:	2,15 kg

SEALING CAP

Ordering code:
ST00012

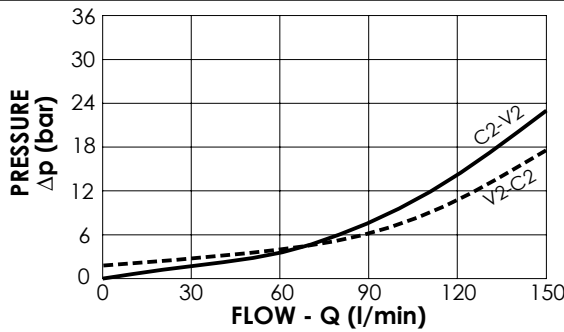
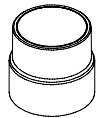

NOTES

Setting: at least 1.3 times the load induced pressure

ORDERING CODES

Quick code	Description	Pilot ratio	Main ports size	Standard setting (bar, Q=5 l/min)	Adjust. range (bar)	Pressure increase (bar/turn)
MB000428	MBDN-150-ZBNV-04-G34-N350	4:1	V1,V2: G3/4" C1,C2: Ø 13	350	100-350	104

OVERCENTRE VALVE

MBDN-300-ZLNR

DOUBLE ACTING

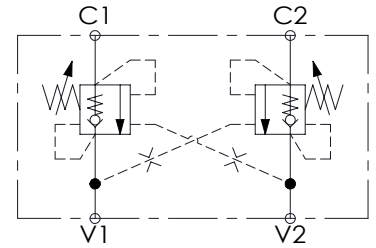
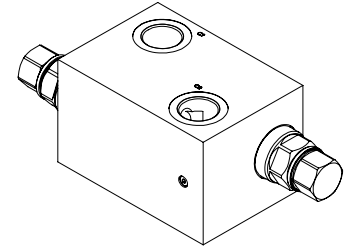
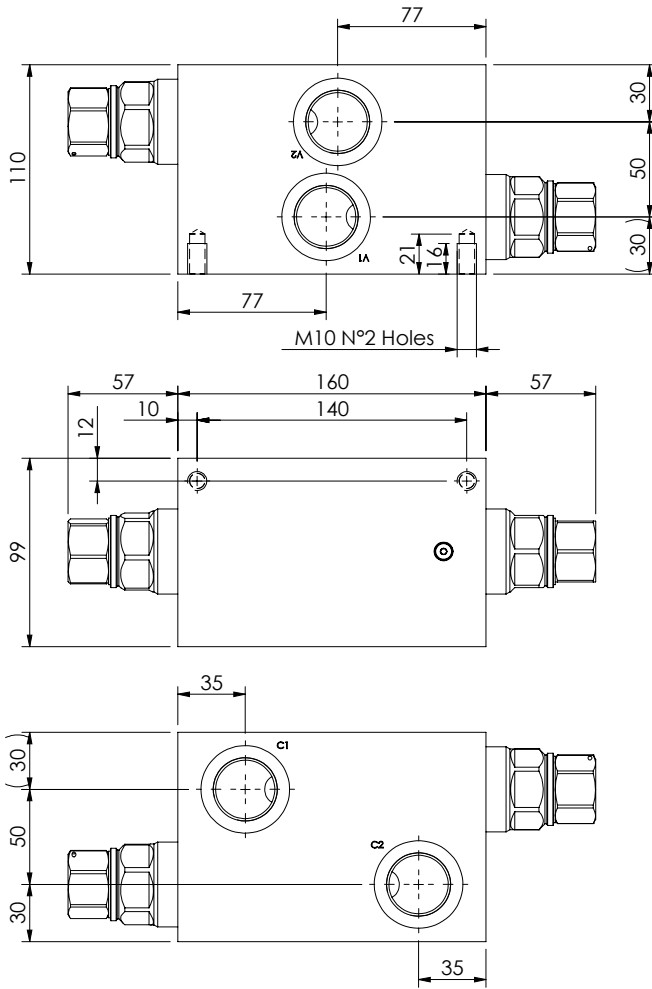

SPECIFICATIONS

Max. operating pressure:	350 bar
Rated flow:	300 l/min
Manifold:	Aluminium
Weight:	5,4 kg

NOTES

Setting: at least 1.3 times the load induced pressure

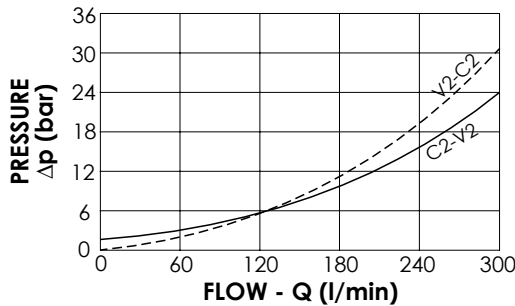

ORDERING CODES

Quick code	Description	Pilot ratio	Main ports size	Standard setting (bar, Q=5 l/min)	Adjust. range (bar)	Pressure increase (bar/turn)
MB000638	MBDN-300-ZLNR-04-G10-N350	4:1	V1,V2,C1,C2: G 1"	350	100 - 350	75

OVERCENTRE VALVE

MBDP-060-ALNR

**DOUBLE ACTING
RELIEF COMPENSATED**

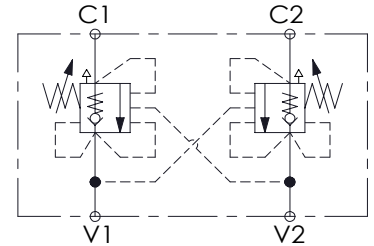
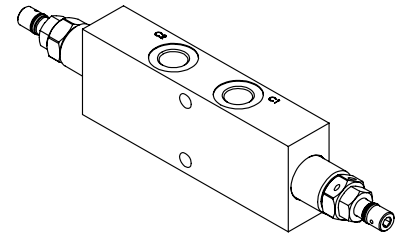
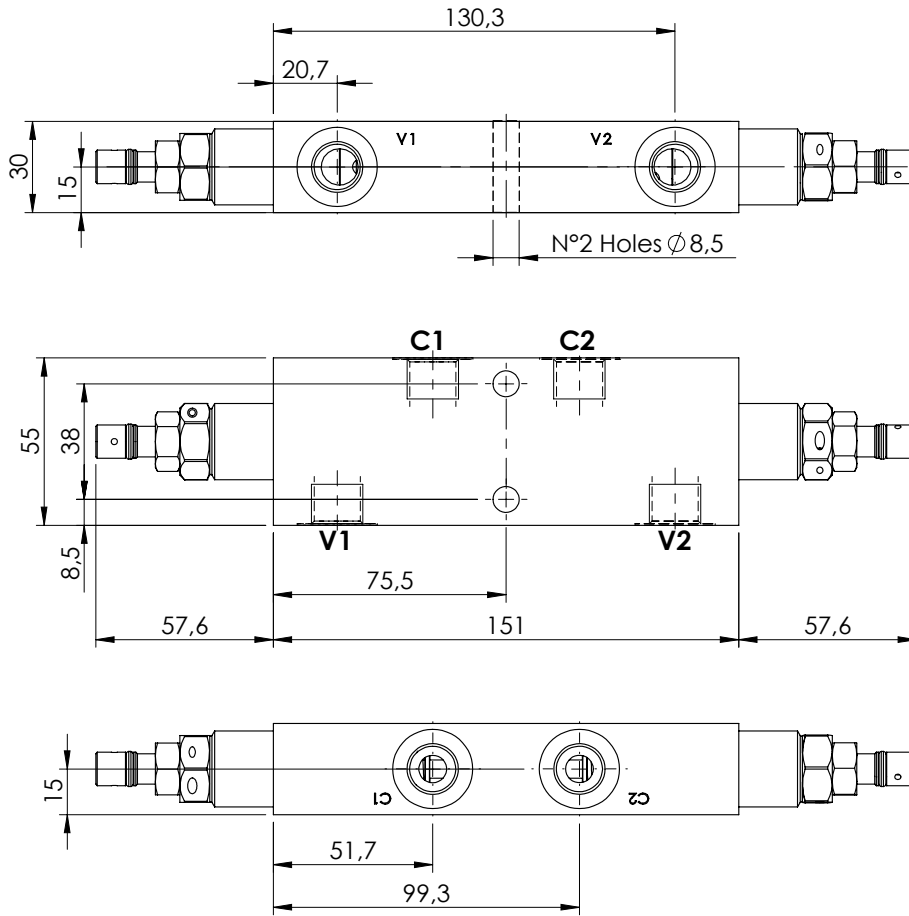

SPECIFICATIONS

Max. operating pressure:	350 bar
Rated flow:	60 l/min
Manifold:	Steel
Weight:	1,98 kg

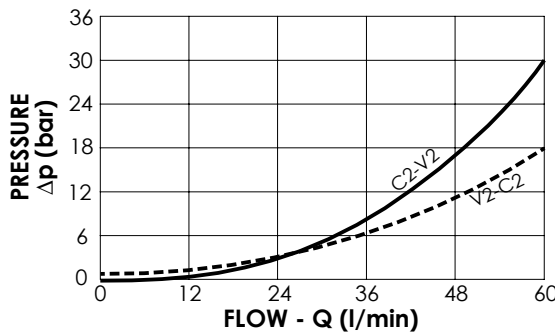

NOTES

Setting: at least 1.3 times the load induced pressure

ORDERING CODES

Quick code	Description	Pilot ratio	Main ports size	Standard setting (bar, Q=5 l/min)	Adjust. range (bar)	Pressure increase (bar/turn)
MB000190	MBDP-060-ALNR-04-G38-N350	4,2:1	V1, V2: G3/8" C1, C2: G3/8"	350	100-350	166
MB000191	MBDP-060-ALNR-04-G38-N200	4,2:1	V1, V2: G3/8" C1, C2: G3/8"	200	60-210	75

OVERCENTRE VALVE

MBDP-060-ALNR

DOUBLE ACTING
RELIEF COMPENSATED

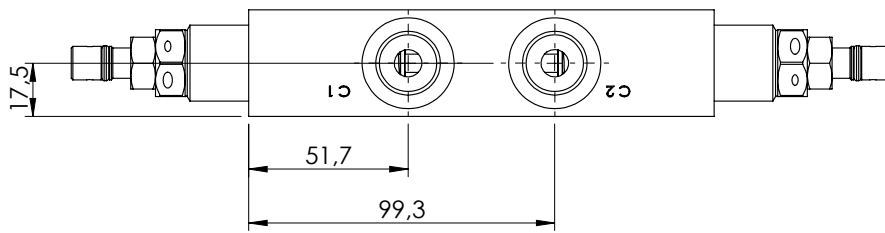
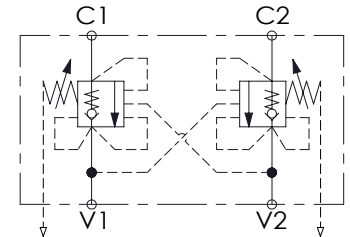
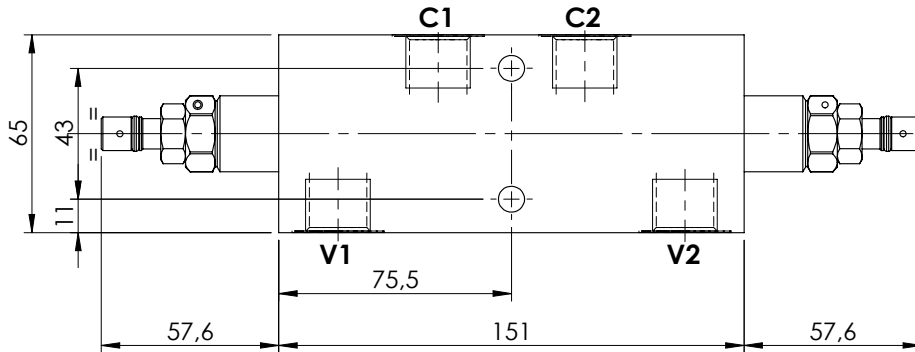
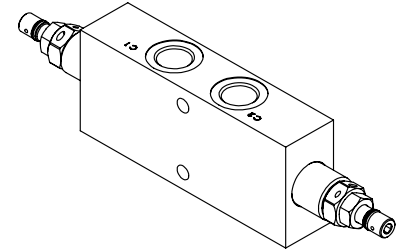
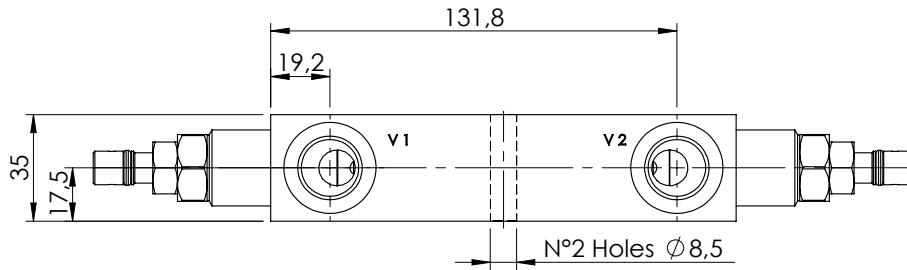

SPECIFICATIONS

Max. operating pressure:	350 bar
Rated flow:	60 l/min
Manifold:	Steel
Weight:	2,62 kg

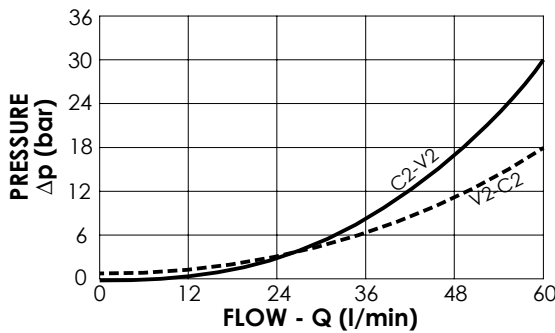

NOTES

Setting: at least 1.3 times the load induced pressure

ORDERING CODES

Quick code	Description	Pilot ratio	Main ports size	Standard setting (bar, Q=5 l/min)	Adjust. range (bar)	Pressure increase (bar/turn)
MB000176	MBDP-060-ALNR-04-G12-N350	4,2:1	V1, V2: G1/2" C1, C2: G1/2"	350	100-350	166
MB000189	MBDP-060-ALNR-04-G12-N200	4,2:1	V1, V2: G1/2" C1, C2: G1/2"	200	60-210	75

OVERCENTRE VALVE

MBDP-060-ZLDE

**DOUBLE ACTING
RELIEF COMPENSATED**

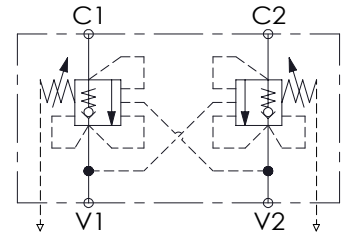
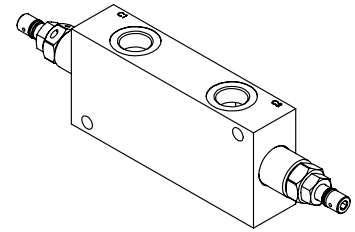
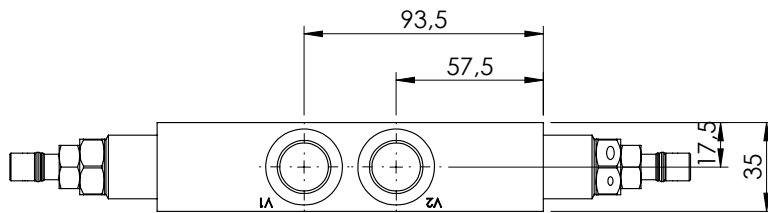
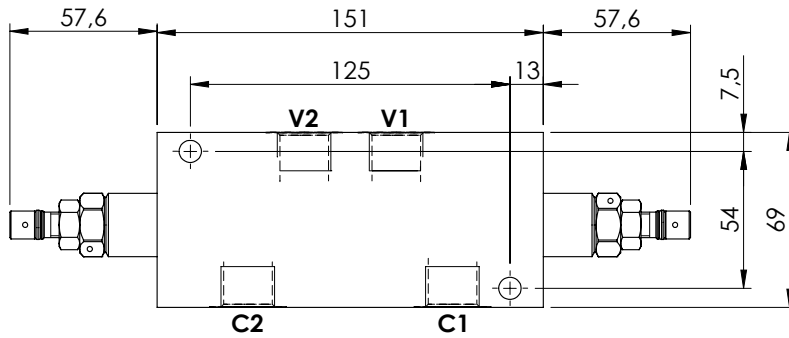
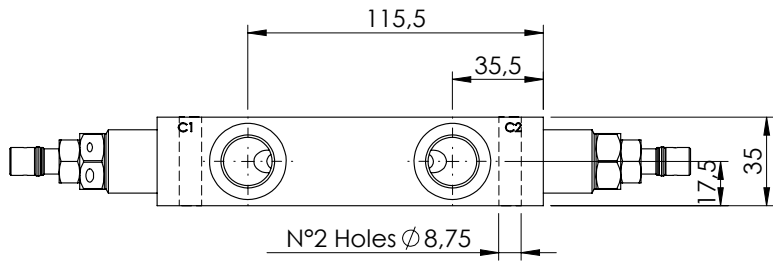

SPECIFICATIONS

Max. operating pressure:	350 bar
Rated flow:	60 l/min
Weight:	Aluminium 1.1 kg; Steel 2.7 kg

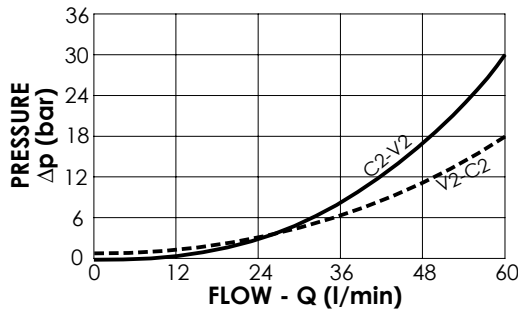

NOTES

Setting: at least 1.3 times the load induced pressure

ORDERING CODES

Quick code	Description	Pilot ratio	Manifold material	Main ports size	Standard setting (bar, Q=5 l/min)	Adjust. range (bar)	Pressure increase (bar/turn)
MB000322	MBDP-060-ZLDE-04-G12-N350	4,2:1	Aluminium	V1, V2: G1/2" C1, C2: G1/2"	350	100-350	166
MB000449	MBDP-060-ZLDE-04-G12-N200	4,2:1	Aluminium	V1, V2: G1/2" C1, C2: G1/2"	200	60-210	75
MB000450	MBDP-060-ALDE-04-G12-N350	4,2:1	Steel	V1, V2: G1/2" C1, C2: G1/2"	350	100-350	166
MB000451	MBDP-060-ALDE-04-G12-N200	4,2:1	Steel	V1, V2: G1/2" C1, C2: G1/2"	200	60-210	75

OVERCENTRE VALVE

MBDP-150-ZLDE

DOUBLE ACTING
RELIEF COMPENSATED

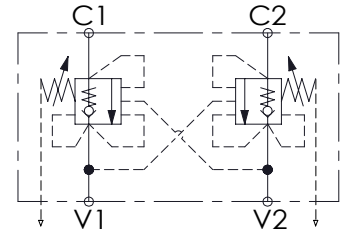
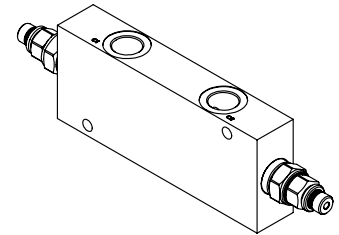
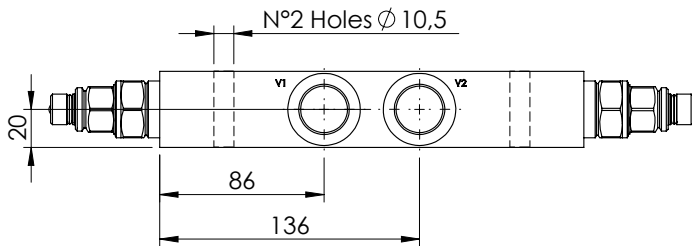
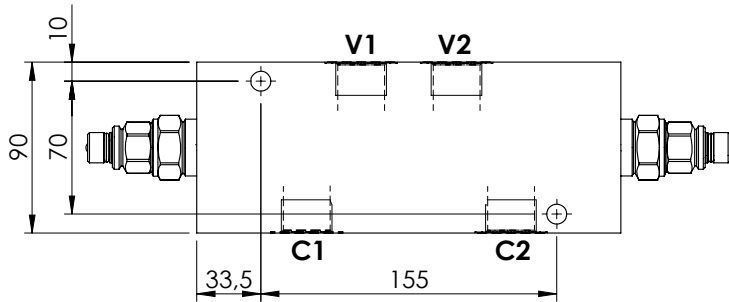
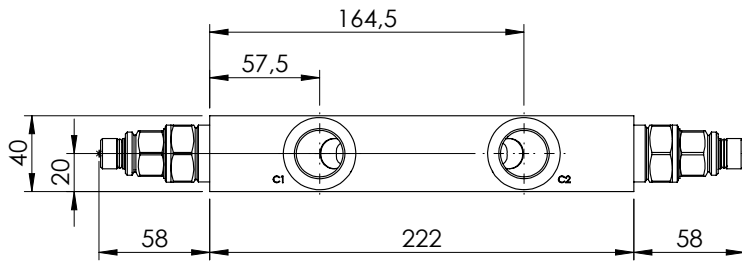

SPECIFICATIONS

Max. operating pressure:	350 bar
Rated flow:	150 l/min
Weight:	Aluminium 2,5 kg; Steel 5.84 kg

SEALING CAP

Ordering code:
ST000012

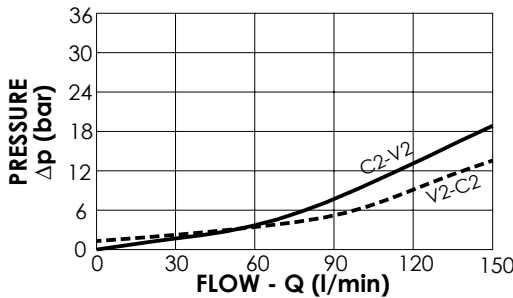

NOTES

Setting: at least 1.3 times the load induced pressure

Hex key for setting the valve:

Ordering code:
PV000669

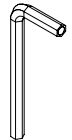

ORDERING CODES

Quick code	Description	Pilot ratio	Manifold material	Main ports size	Standard setting (bar, Q=5 l/min)	Adjust. range (bar)	Pressure increase (bar/turn)
MB000436	MBDP-150-ZLDE-04-G34-N350	4:1	Aluminium	V1, V2: G3/4" C1, C2: G3/4"	350	100-350	104
MB000437	MBDP-150-ZLDE-04-G34-N200	4:1	Aluminium	V1, V2: G3/4" C1, C2: G3/4"	200	60-210	56
MB000438	MBDP-150-ALDE-04-G34-N350	4:1	Steel	V1, V2: G3/4" C1, C2: G3/4"	350	100-350	104
MB000439	MBDP-150-ALDE-04-G34-N200	4:1	Steel	V1, V2: G3/4" C1, C2: G3/4"	200	60-210	56
MB000416	MBDP-150-ZLDE-08-G34-N350	8:1	Aluminium	V1, V2: G3/4" C1, C2: G3/4"	350	200-350	82
MB000417	MBDP-150-ZLDE-08-G34-N200	8:1	Aluminium	V1, V2: G3/4" C1, C2: G3/4"	200	60-210	47
MB000422	MBDP-150-ALDE-08-G34-N350	8:1	Steel	V1, V2: G3/4" C1, C2: G3/4"	350	200-350	82
MB000423	MBDP-150-ALDE-08-G34-N200	8:1	Steel	V1, V2: G3/4" C1, C2: G3/4"	200	60-210	47

OVERCENTRE VALVE

MBDT-150-ZBNV

**DOUBLE ACTING
TWO FLANGED PORTS
COMPENSATED**

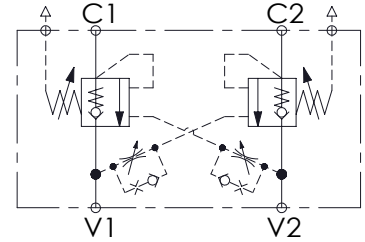
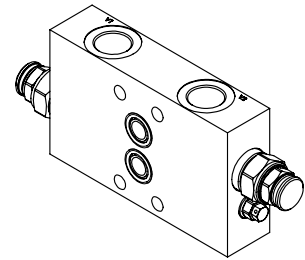
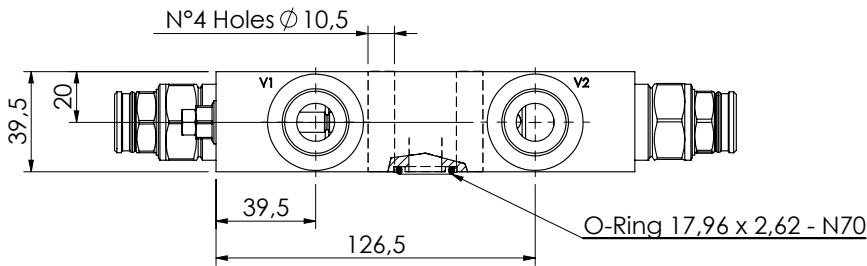
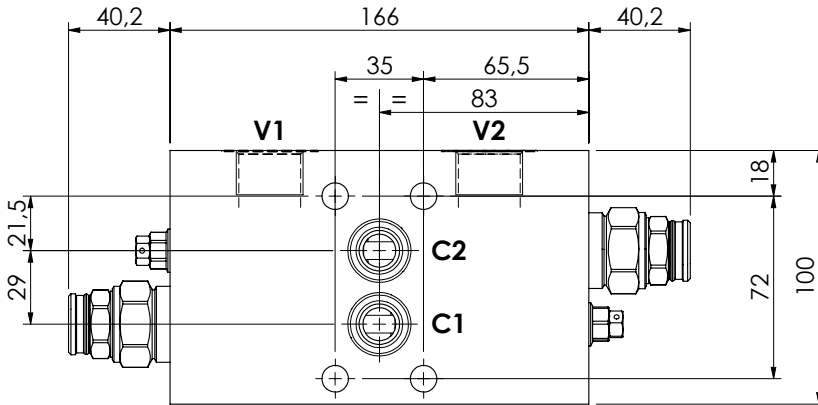

SPECIFICATIONS

Max. operating pressure:	350 bar
Rated flow:	150 l/min
Weight: Aluminium	2,14 kg; Steel 4,85 kg

SEALING CAP

Ordering code:
ST000012

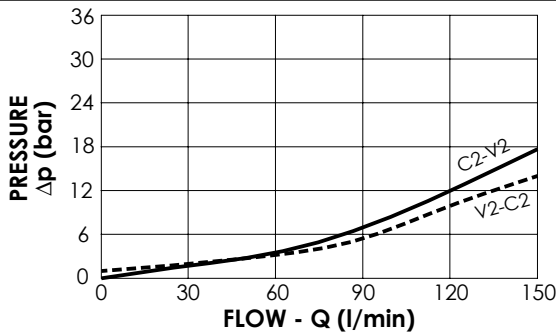
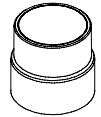

NOTES

Setting: at least 1.3 times the load induced pressure

ORDERING CODES

Quick code	Description	Pilot ratio	Manifold material	Main ports size	Standard setting (bar, Q=5 l/min)	Adjust. range (bar)	Pressure increase (bar/turn)
MB000429	MBDT-150-ZBNV-04-G34-N350	4:1	Aluminium	V1,V2: G 3/4" C1,C2: Ø 13	350	100-350	104
MB000641	MBDT-150-ZBNV-04-G12-N350	4:1	Aluminium	V1,V2: G 1/2" C1,C2: Ø 13	350	100-350	104
MB000646	MBDT-150-ABNV-04-G34-N350	4:1	Steel	V1,V2: G 3/4" C1,C2: Ø 13	350	100-350	104
MB000647	MBDT-150-ABNV-04-G12-N350	4:1	Steel	V1,V2: G 1/2" C1,C2: Ø 13	350	100-350	104

OVERCENTRE VALVE

MBDN-500-ABNR DOUBLE ACTING

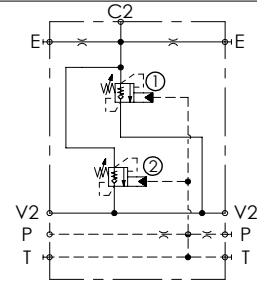
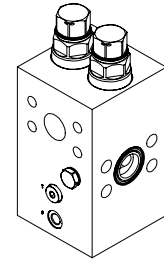
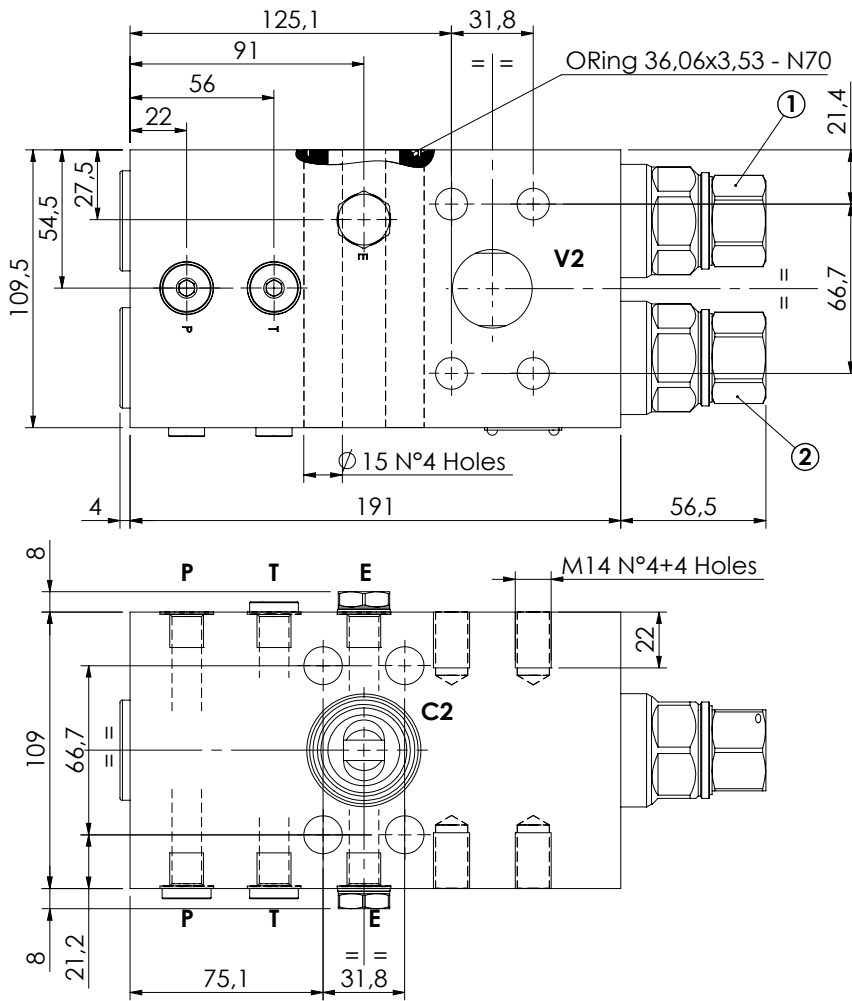

SPECIFICATIONS

Max. operating pressure:	420 bar
Rated flow:	500 l/min
Manifold:	Steel
Weight:	16,32 kg

NOTES

T line plugs must be kept closed

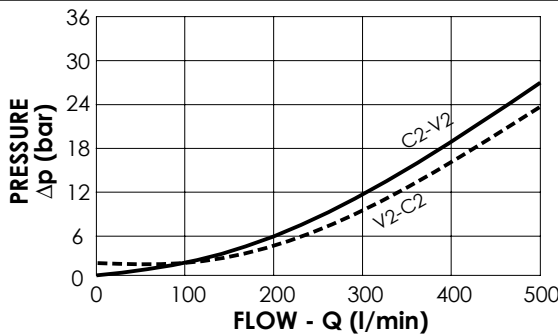

ORDERING CODES

Quick code	Description	Pilot ratio	Main ports size	Standard setting (bar)	Adjust. range (bar)	Pressure increase (bar/turn)
MB000979	MBDN-500-ABNR-06-S11-N420	6:1	V2,C2:1 1/4" SAE 6000 P,T,E: G 1/4"	420	250-420	104

OVERCENTRE VALVE

MBDN-500-ABNR DOUBLE ACTING

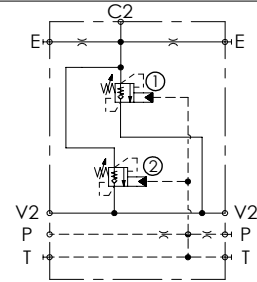
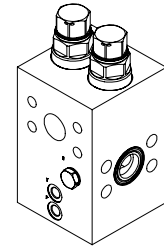
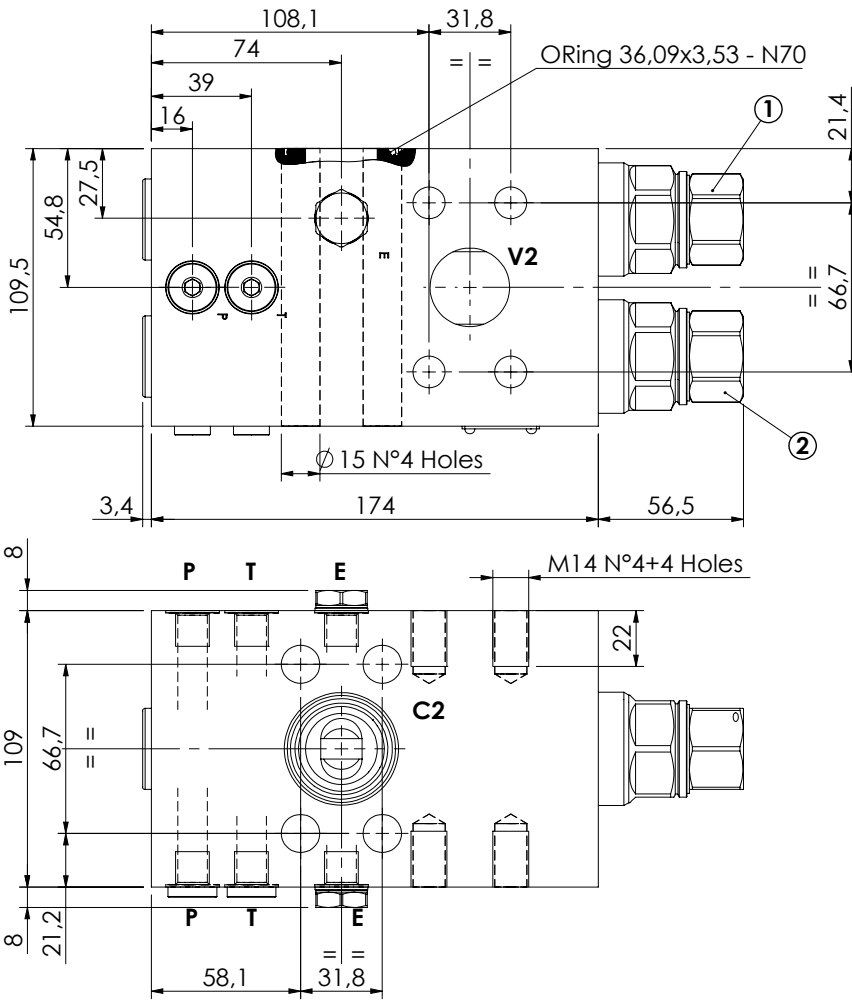

SPECIFICATIONS

Max. operating pressure:	420 bar
Rated flow:	500 l/min
Manifold:	Steel
Weight:	14,78 kg

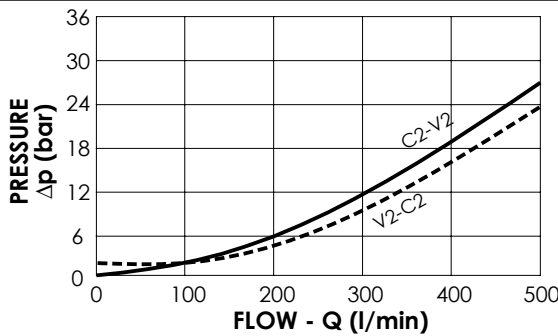

NOTES

T line plugs must be kept closed

ORDERING CODES

Quick code	Description	Pilot ratio	Main ports size	Standard setting (bar)	Adjust. range (bar)	Pressure increase (bar/turn)
MB000978	MBDN-500-ABNR-13-S11-N420	13:1	V2,C2:1 1/4" SAE 6000 P,T,E: G 1/4"	350	250-420	104



1800-OILSOL
1800-645765

<https://oilsolutions.com.au/>

sales@oilsolutions.com.au



ATLANTIC
Fluid Tech

SECTION 7

Regeneratives Valves



1800-OILSOL
1800-645765

<https://oilsolutions.com.au/>

sales@oilsolutions.com.au

SECTION 7

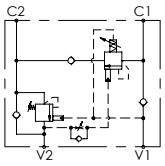
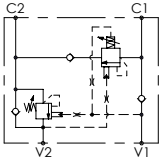
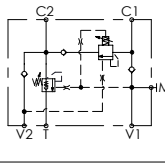
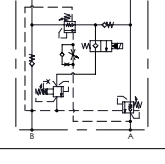
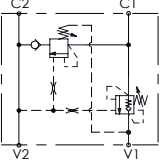
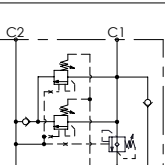

REGENERATIVE VALVES

Hydraulic scheme	Valve description	Valve type	Rated flow (l/min)	Max. pressure (bar)	Installation	Main port size or cavity type	Page
	MRSN-060-ZBNV	Single overcentre with regenerative	60	350	Flanged	G 3/8"	7.01.010
	MRLN-060-ZLNP	Single overcentre with regenerative	60	350	In line	G 1/2"	7.02.020
	MRSN-150-ZLNV	Single overcentre with regenerative	150	350	In line	G 1/2"	7.03.030
	MRDN-100-ZLNV	Double overcentre with regenerative	100	350	In line	G 3/4"	7.04.040
	MRSN-300-ABNV	Single overcentre with regenerative	300	420	Flanged	3/4" SAE 6000	7.05.050
	MRSN-300-ABNE	Single overcentre with double regenerative	500	420	Flanged	1"-1/4 SAE 6000	7.06.060

REGENERATIVE VALVE

MRSN-060-ZBNV

REGENERATIVE

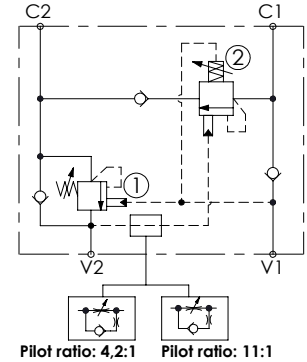
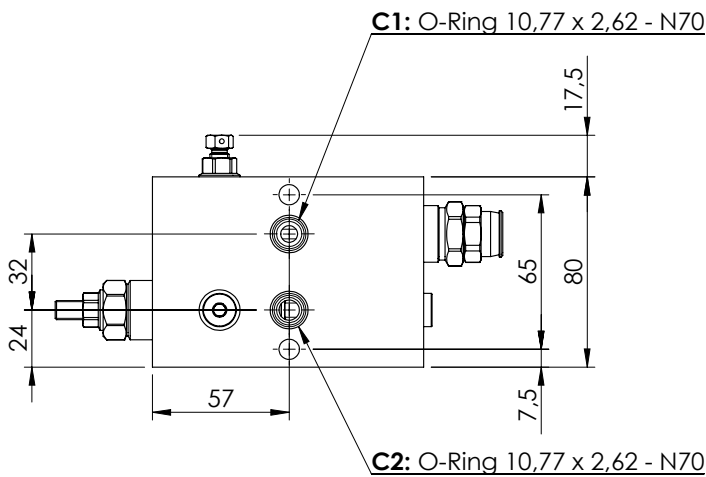
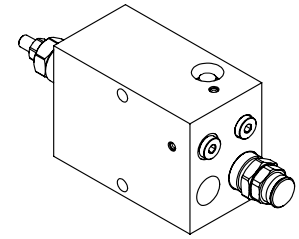
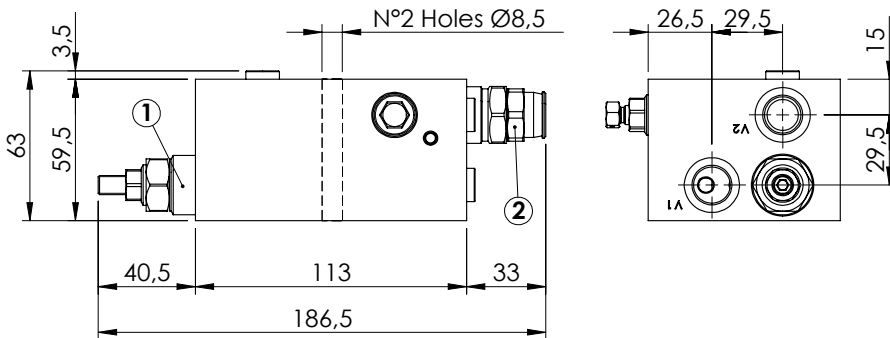

SPECIFICATIONS

Max. operating pressure:	350 bar
Rated flow:	60 l/min
Manifold:	Aluminium
Weight:	1,6 kg

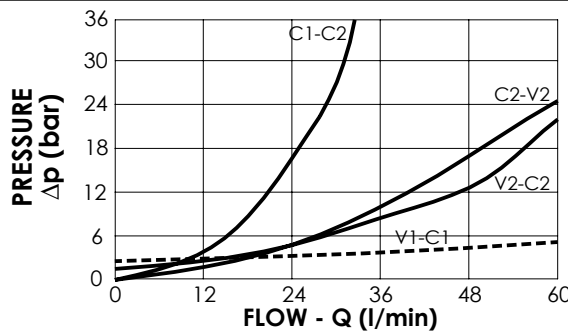

NOTES

Setting: at least 1.3 times the load induced pressure
 Designed for aerial platforms

ORDERING CODES

Quick code	Description	Pilot ratio	Main ports size	Standard setting (bar, Q=5 l/min)	Adjust. range (bar)	Pressure increase (bar/turn)
MB000035	MRSN-060-ZBNV-11-G38-N350	11:1	V1,V2 : G3/8" C1,C2 : Ø 7	350	100-350	69
MB000085	MRSN-060-ZBNV-04-G38-N350	4,2:1	V1,V2 : G3/8" C1,C2 : Ø 7	350	100-350	139

REGENERATIVE VALVE

MRSN-060-ZLNP

REGENERATIVE

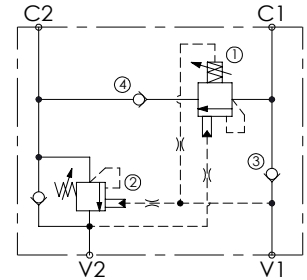
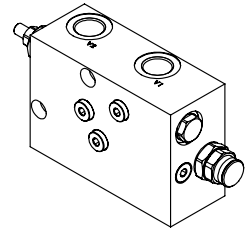
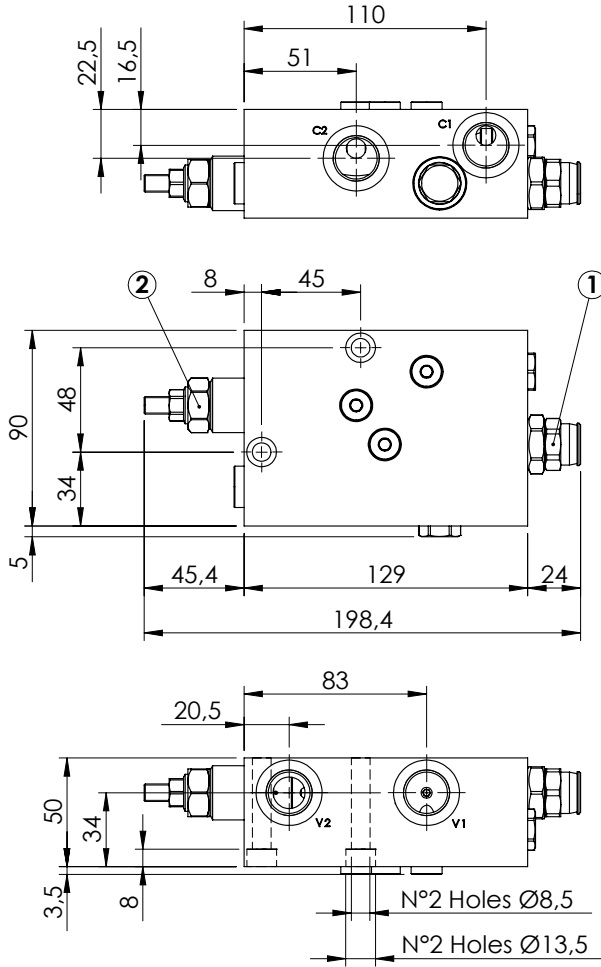

SPECIFICATIONS

Max. operating pressure:	350 bar
Rated flow:	60 l/min
Manifold:	Aluminium
Weight:	1,71 kg

NOTES

Setting: at least 1.3 times the load induced pressure

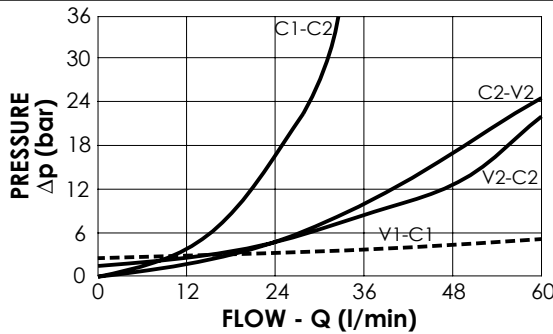

ORDERING CODES

Quick code	Description	Pilot ratio	Main ports size	Standard setting (bar, Q=5 l/min)	Adjust. range (bar)	Pressure increase (bar/turn)
MB000150	MRSN-060-ZLNP-04-G12-N350	4,2:1	V1,V2,C1,C2 : G 1/2"	170	60-210	62

REGENERATIVE VALVE

MRSN-150-ZLNV

REGENERATIVE

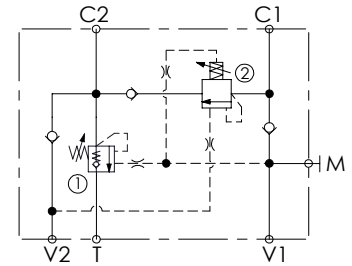
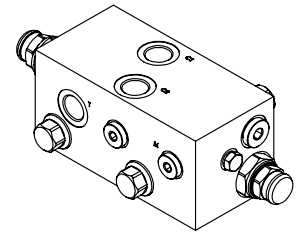
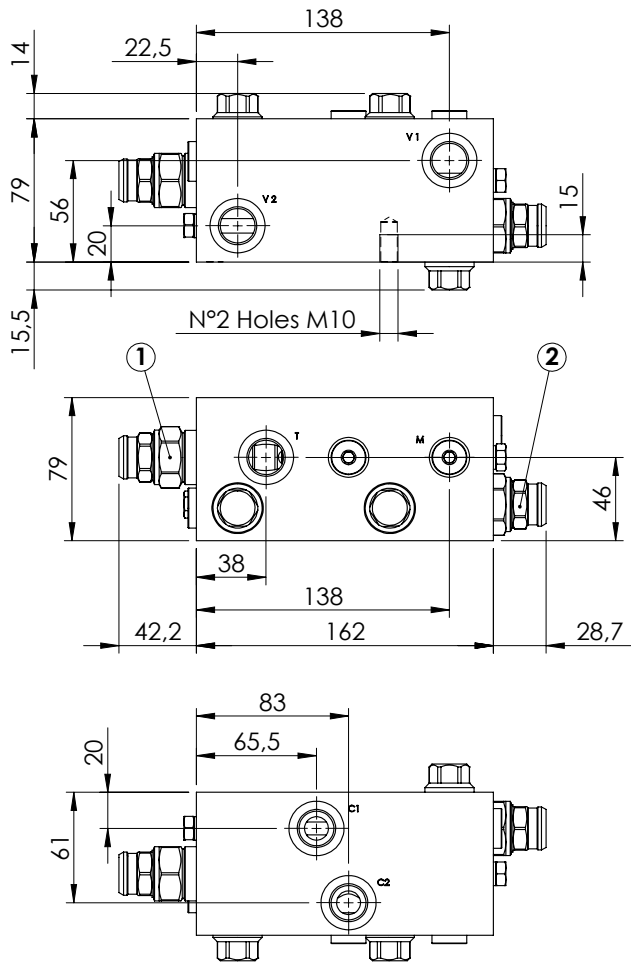

SPECIFICATIONS

Max. operating pressure:	350 bar
Rated flow:	150 l/min
Manifold:	Aluminium
Weight:	3,18 kg

NOTES

Setting: at least 1.3 times the load induced pressure
 Designed for truck mounted cranes

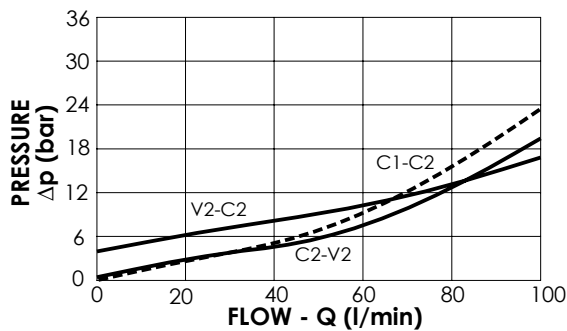

ORDERING CODES

Quick code	Description	Pilot ratio	Main ports size	Standard setting (bar, Q=5 l/min)	Adjust. range (bar)	Pressure increase (bar/turn)
MB000113	MRSN-150-ZLNV-04-G12-N350	4:1	V1,V2,C1,C2,T : G1/2" M: G1/4"	350	100-350	104

REGENERATIVE VALVE

MRDN-150-ZLNV

REGENERATIVE

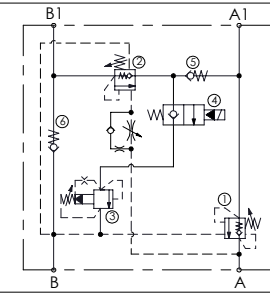
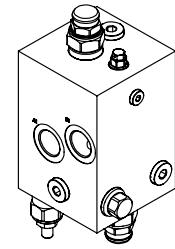
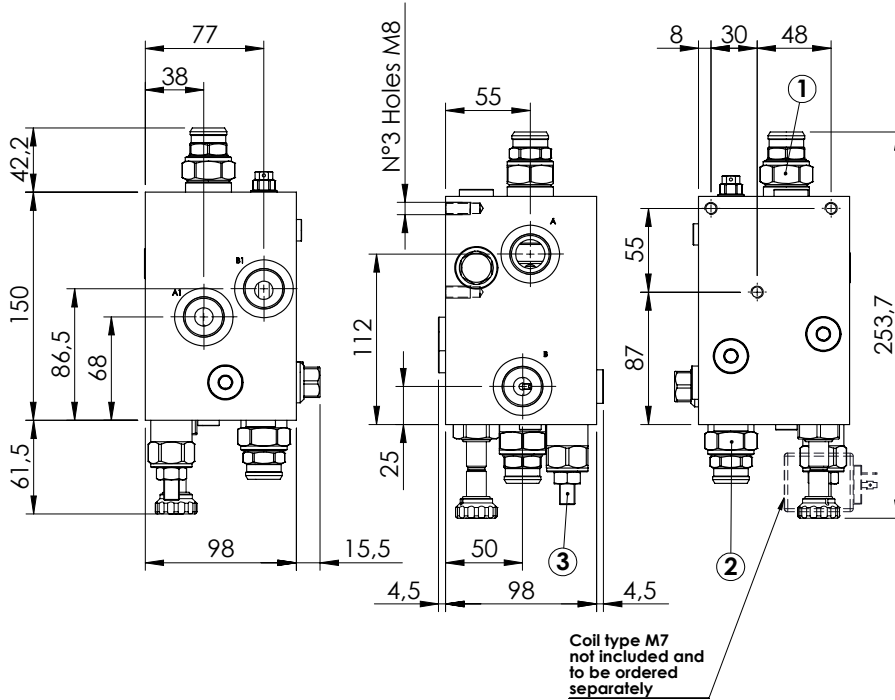

SPECIFICATIONS

Max. operating pressure:	210 bar
Rated flow:	100 l/min
Manifold:	Aluminium
Weight:	4,62 kg
Coil type:	M7

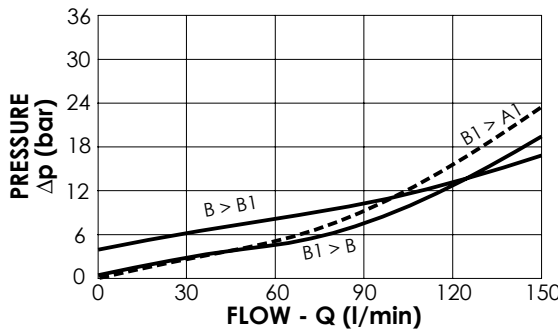

NOTES

Setting: at least 1.3 times the load induced pressure
 Designed for truck mounted cranes
 See chapter 18.00.000 for coils.

ORDERING CODES

Quick code	Description	Pilot ratio	Main ports size	Standard setting (bar, Q=5 l/min)	Adjust. range (bar)	Pressure increase (bar/turn)
MB000476	MRDN-100-ZLNV-04-G34-N210	4:1	A,A1,B,B1 : G3/4"	①② 350 ③ 350	①② 100-350 ③ 140-350	①② 103 ③ 114

REGENERATIVE VALVE

MRSN-300-ABNV

REGENERATIVE

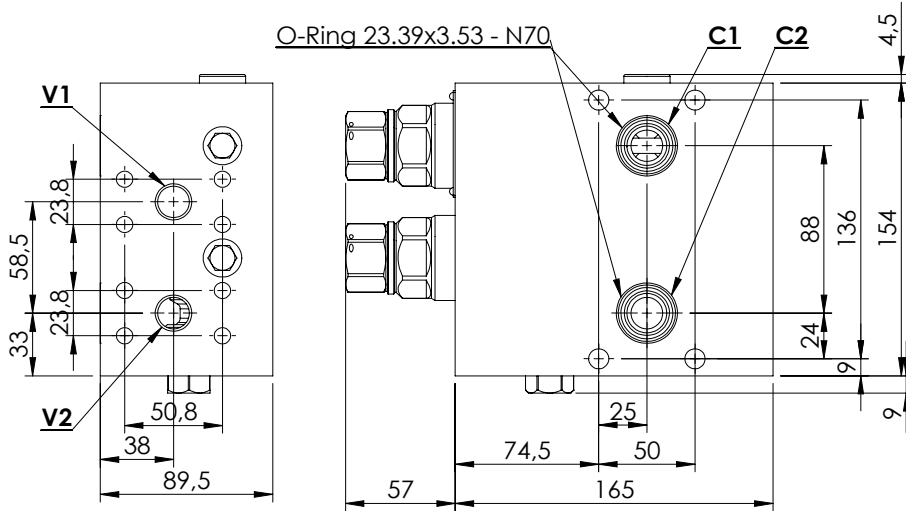
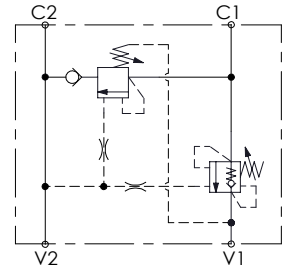
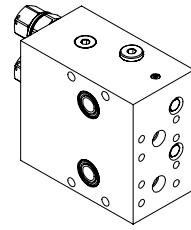
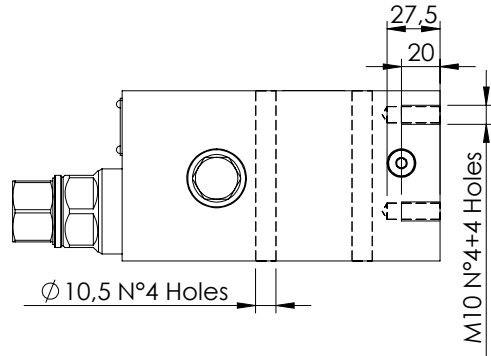

SPECIFICATIONS

Max. operating pressure:	420 bar
Rated flow:	300 l/min
Manifold:	Steel
Weight:	16,86 kg

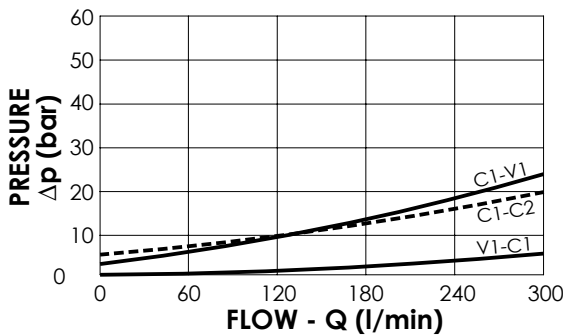

NOTES

Setting: at least 1.3 times the load induced pressure

ORDERING CODES

Quick code	Description	Pilot ratio	Main ports size	Standard setting (bar, Q=5 l/min)	Adjust. range (bar)	Pressure increase (bar/turn)
MB000816	MRSN-300-ABNV-06-S34-N420	6:1	V1,V2: 3/4" SAE 6000 C1,C2: Ø16,5	250	120-360	122

REGENERATIVE VALVE

MRSN-300-ABNE

REGENERATIVE

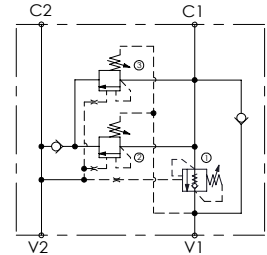
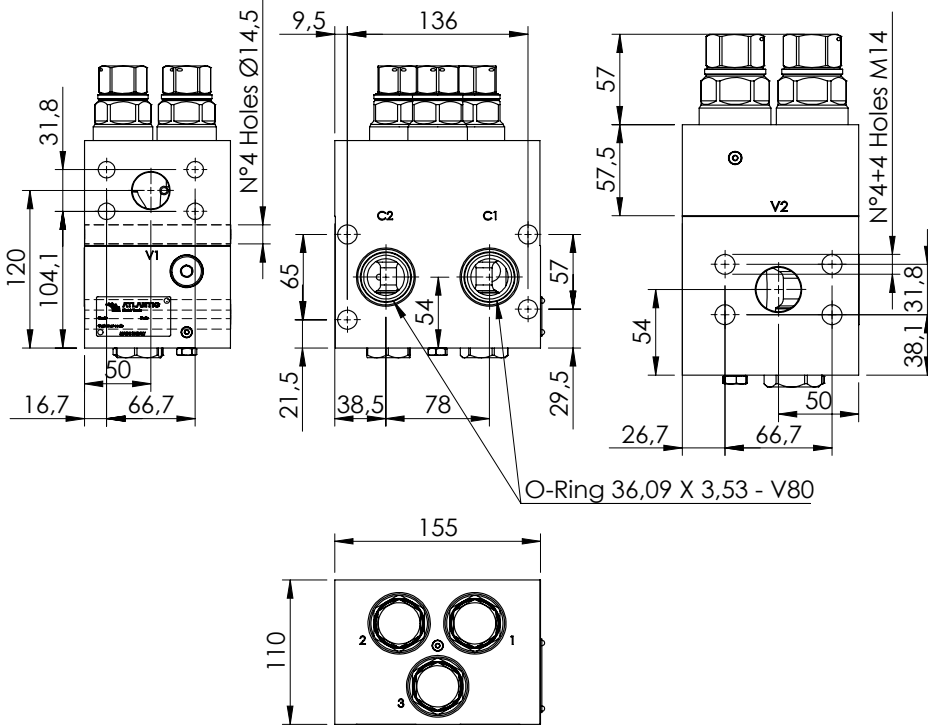
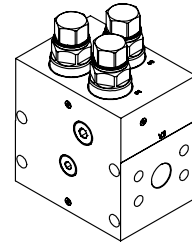

SPECIFICATIONS

Max. operating pressure:	420 bar
Rated flow:	300 l/min
Manifold:	Steel
Weight:	18,82 kg

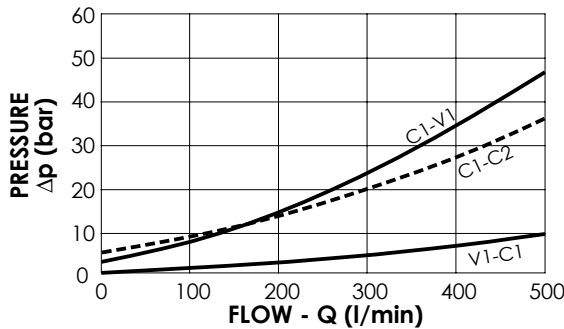

NOTES

Designed for crusher scissors
Valve for heavy duty working cycles with viton seals and reinforced plugs

ORDERING CODES

Quick code	Description	Pilot ratio	Main ports size	Standard setting (bar, Q=5 l/min)	Adjust. range (bar)	Pressure increase (bar/turn)
MB000132	MRSN-300-ABNE-06-S11-V420	6:1	V1,V2: 1-1/4 SAE 6000 C1,C2: Ø 28	250	120-360	104



ATLANTIC
Fluid Tech

SECTION 8

Hydraulic
Motors,
Actuators
and Winch
Valves



1800-OILSOL
1800-645765

<https://oilsolutions.com.au/>

sales@oilsolutions.com.au

SECTION 8

**HYDRAULIC MOTOR, ACTUATOR,
AND WINCH VALVES**



Hydraulic scheme	Valve description	Valve type	Rated flow (l/min)	Max. pressure (bar)	Installation	Main port size or cavity type	Page
	MADN-030-TLNR	Double antishock	30	350	In line	G 3/8"	8.01.010
	MADN-030-TLNR	Double antishock	30	350	In line	G 1/2"	8.01.020
	MADN-030-TBNR	Double antishock, for SD OMP-OMR	30	210	Flanged	G 1/2"	8.01.030
	MADN-080-TLNR	Double antishock	80	350	In line	G 1/2"	8.01.040
	MADN-040-LLNR	Dual cross over and anticavitation relief	40	210	In line	G 1/2"	8.02.050
	MADN-080-LLNR	Dual cross over and anticavitation relief	80	250	In line	G 3/4"	8.03.060
	MBDN-055-GLNR	Counterbalance, dual acting	55	350	In line	G 3/8"	8.04.070
	MBDN-055-GLSF	Counterbalance, dual acting, with brake release	55	350	In line	G 3/8"	8.05.080
	MFLN-150-RFSR	Flushing	150	350	Flanged	Ø13	8.06.090
	MFLN-300-RFSR	Flushing	300	350	Flanged	Ø19	8.06.100
	MFLN-500-RFSR	Flushing	500	350	Flanged	Ø25	8.06.110
	MBSN-060-ZMSF	Single acting, brake release, for SD OMS motor	60	350	Flanged	G 1/2"	8.07.120
	MBSN-060-ZMSF	Single acting, brake release, for SD OMP motor	60	350	Flanged	G 1/2"	8.07.130
	MBDN-060-ALSF	Dual acting, brake release	60	350	In line	G 3/8"	8.08.140
	MBDN-060-ALSF	Dual acting, brake release	60	350	In line	G 1/2"	8.08.150
	MBDN-060-ZMSF	Dual acting, brake release	60	250	Flanged	Ø9	8.08.160
	MBDN-060-ZMNR	Dual acting, brake release	60	210	Flanged	1/2" SAE 6000	8.08.170
	MBDN-060-ABSF	Dual acting, brake release	60	350	Flanged	G 1/2"	8.08.180
	MBDN-060-LMSF	Dual acting, brake release, for SD OMS motor	60	250	Flanged	G 1/2"	8.08.190
	MBDN-060-LMSF	Dual acting, brake release, for SD OMP motor	60	250	Flanged	G 1/2"	8.08.200
	MBDN-060-AMSF	Dual acting, brake release, for SAM BR motor	60	250	Flanged	G 1/2"	8.08.210
	MBDN-060-AMSF	Dual acting, brake release, for SAM HR motor	60	250	Flanged	G 1/2"	8.08.220
	MBDN-060-AMSR	Dual acting, brake release, for BR A2FE 28-32	60	420	Flanged	1/2" SAE 6000	8.09.230
	MBDN-100-AMSR	Dual acting, brake release, for BR A2FE 28-32	100	420	Flanged	1/2" SAE 6000	8.09.240
	MBDN-150-AMSR	Dual acting, brake release, for BR A2FE 45-56-63	150	420	Flanged	3/4" SAE 6000	8.09.250
	MBDN-150-AMSR	Dual acting, brake release, for BR A2FE 80-90	180	420	Flanged	1" SAE 6000	8.09.260
	MBDN-300-AMSR	Dual acting, brake release, for BR A2FE 80-90	300	420	Flanged	1" SAE 6000	8.09.270
	MBDN-320-AMSR	Dual acting, brake release, for BR A2FE 107-125-160-180	320	420	Flanged	1-1/4" SAE 6000	8.09.280

SECTION 8

**HYDRAULIC MOTOR, ACTUATOR,
AND WINCH VALVES**



Hydraulic scheme	Valve description	Valve type	Rated flow (l/min)	Max. pressure (bar)	Installation	Main port size or cavity type	Page
	MBSN-100-ZMSF	Single acting for winches, pilot assisted, for SD OMS motor	100	350	Flanged	G 1/2"	8.10. 290
	MBSN-250-AMSF	Single acting for winches, brake release	250	500	Flanged	3/4" SAE 6000	8.11. 300
	MBSN-300-AMSF	Single acting for winches, brake release	300	500	Flanged	1" SAE 6000	8.11. 310
	MBSN-300-AMSF	Single acting for winches, brake release	300	500	Flanged	1-1/4" SAE 6000	8.11. 320
	MBDN-500-AMSF	Double acting for winches, brake release	500	500	Flanged	1-1/4" SAE 6000	8.12. 330

VALVES FOR MOTORS OR HYDRAULIC ACTUATORS

MADN-030-TLNR

DOUBLE ANTISHOCK

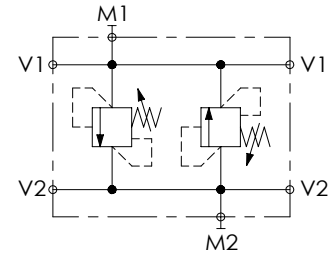
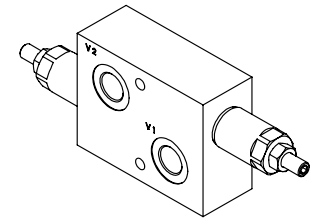
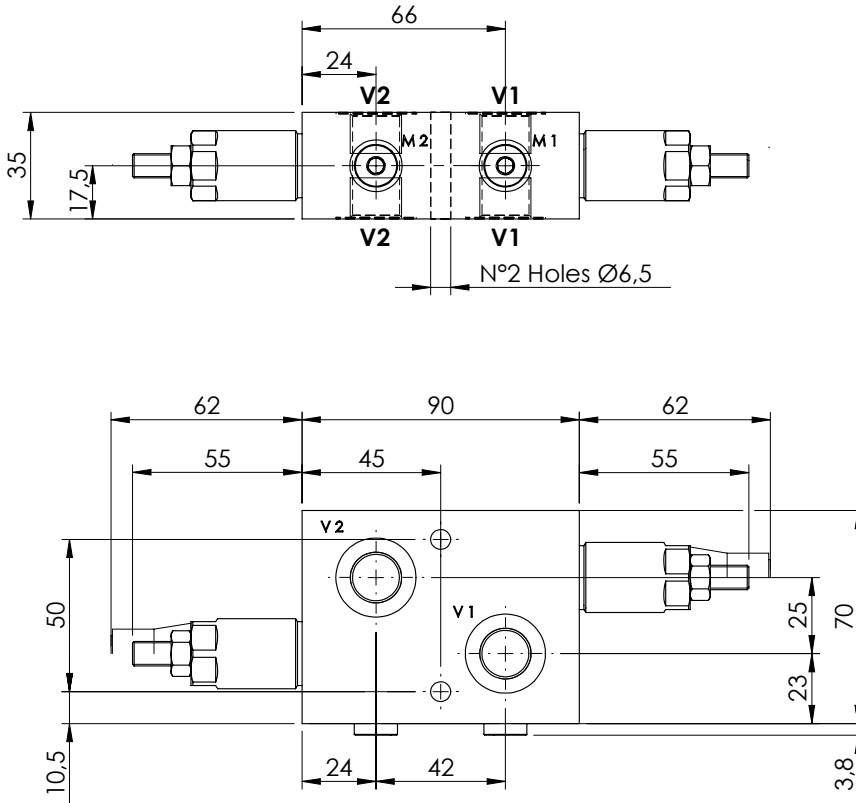

SPECIFICATIONS

Max. operating pressure:	350 bar
Rated flow:	30 l/min
Manifold:	Aluminium
Weight:	0,8 kg

SEALING CAP

Ordering code:
AT000020

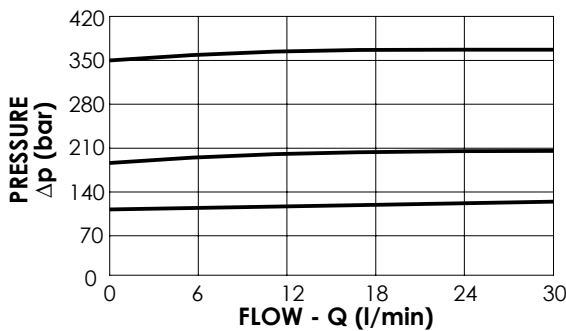
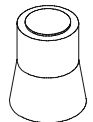

ORDERING CODES

Quick code	Description	Main ports size	Standard setting (bar, Q=5 l/min)	Adjust. range (bar)	Pressure increase (bar/turn)
MA000006	MADN-030-TLNR-HN-G38-N350	V1,V2 : G 3/8" M1,M2 : G1/8"	350	100-350	91
MA000005	MADN-030-TLNR-HN-G38-N200	V1,V2 : G 3/8" M1,M2 : G1/8"	200	50-210	42
MA000004	MADN-030-TLNR-HN-G38-N100	V1,V2 : G 3/8" M1,M2 : G1/8"	100	30-100	20

VALVES FOR MOTORS OR HYDRAULIC ACTUATORS

MADN-030-TLNR

DOUBLE ANTISHOCK

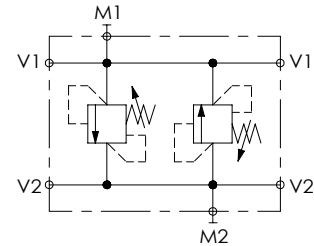
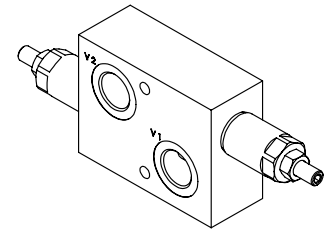
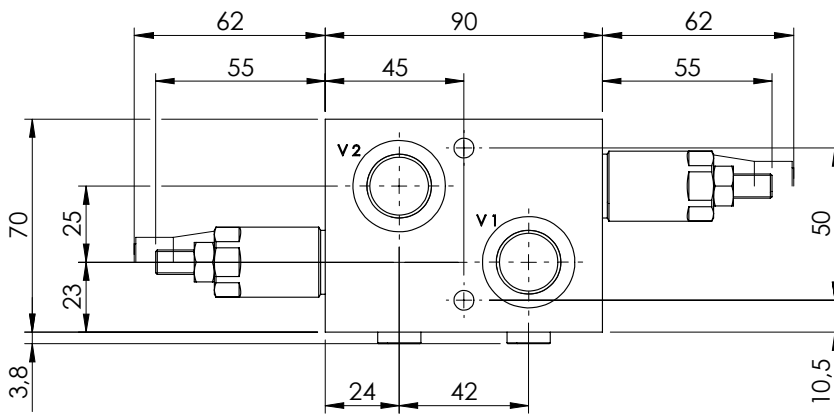
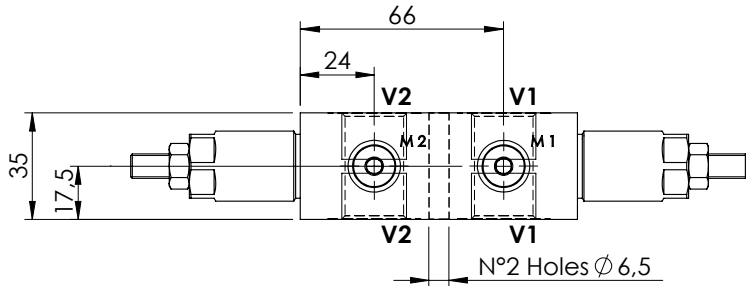

SPECIFICATIONS

Max. operating pressure:	350 bar
Rated flow:	30 l/min
Manifold:	Aluminium
Weight:	0,8 kg

SEALING CAP

Ordering code:
AT000020

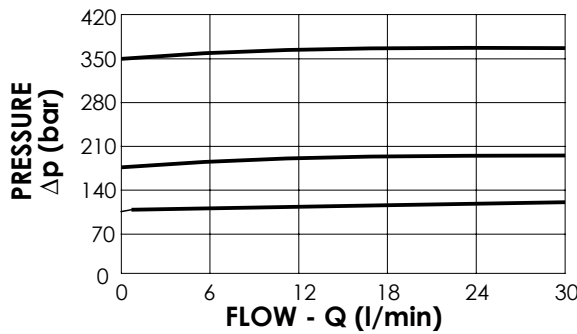
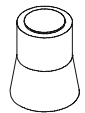

ORDERING CODES

Quick code	Description	Main ports size	Standard setting (bar, Q=5 l/min)	Adjust. range (bar)	Pressure increase (bar/turn)
MA000010	MADN-030-TLNR-HN-G12-N350	V1,V2 : G1/2" M1,M2 : G1/8"	350	100-350	91
MA000007	MADN-030-TLNR-HN-G12-N200	V1,V2 : G1/2" M1,M2 : G1/8"	200	50-210	42
MA000009	MADN-030-TLNR-HN-G12-N100	V1,V2 : G1/2" M1,M2 : G1/8"	100	30-100	20
MA000032	MADN-030-TLNR-HN-G12-N050	V1,V2 : G1/2" M1,M2 : G1/8"	50	10- 50	10

VALVES FOR MOTORS OR HYDRAULIC ACTUATORS

MADN-030-TBNR

DOUBLE ANTISHOCK

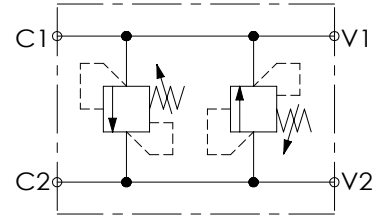
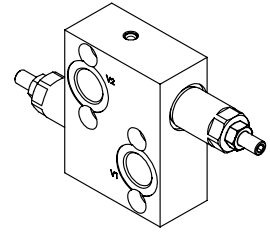
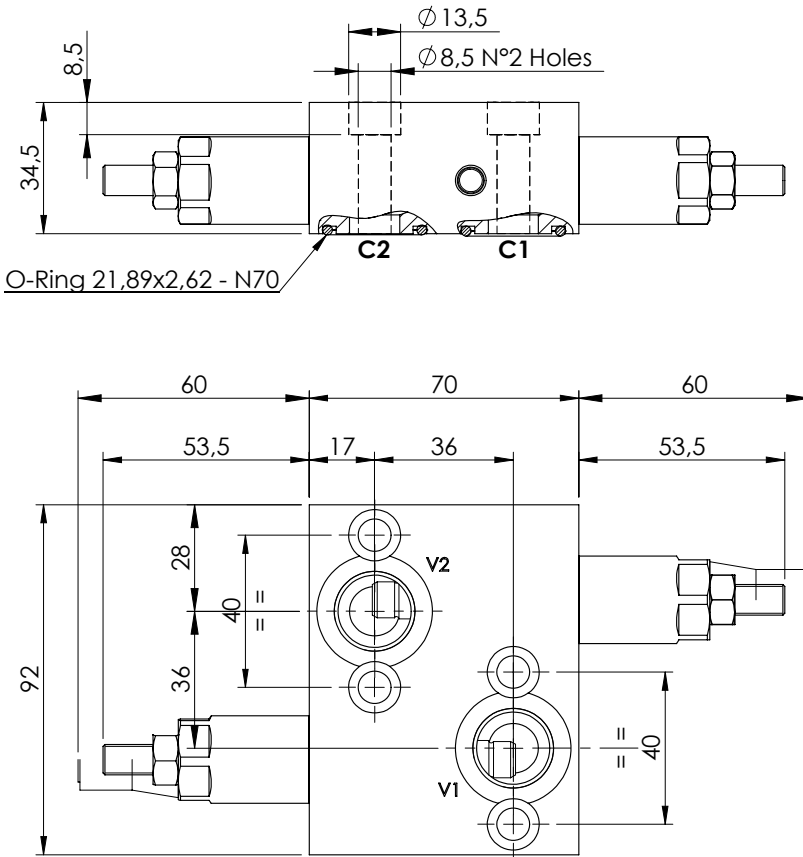

SPECIFICATIONS

Max. operating pressure:	210 bar
Rated flow:	30 l/min
Manifold:	Aluminium
Weight:	0,76 kg

SEALING CAP

Ordering code:
AT000020

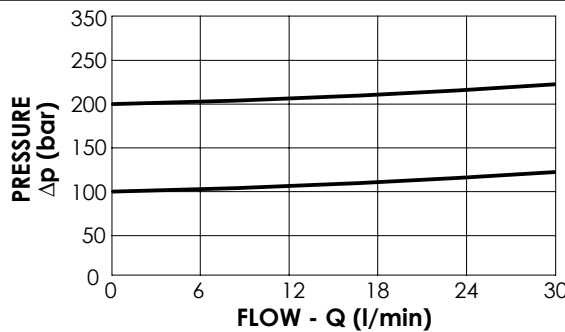
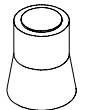

NOTES

Setting: at least 1.3 times the load induced pressure
Designed for DANFOSS motors OMP-OMR series.

ORDERING CODES

Quick code	Description	Main ports size	Standard setting (bar, Q=5 l/min)	Adjust. range (bar)	Pressure increase (bar/turn)
MA000012	MADN-030-TBNR-HN-G12-N210	V1,V2: G 1/2" C1,C2: $\varnothing 13$	200	50-210	42
MA000022	MADN-030-TBNR-HN-G12-N100	V1,V2: G 1/2" C1,C2: $\varnothing 13$	100	30-100	20

VALVES FOR MOTORS OR HYDRAULIC ACTUATORS

MADN-080-TLNR

DOUBLE ANTISHOCK

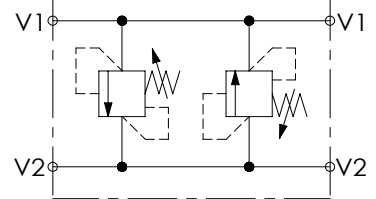
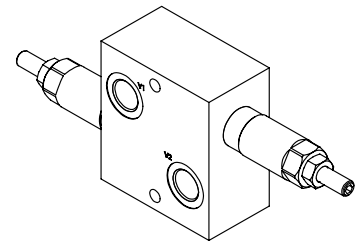
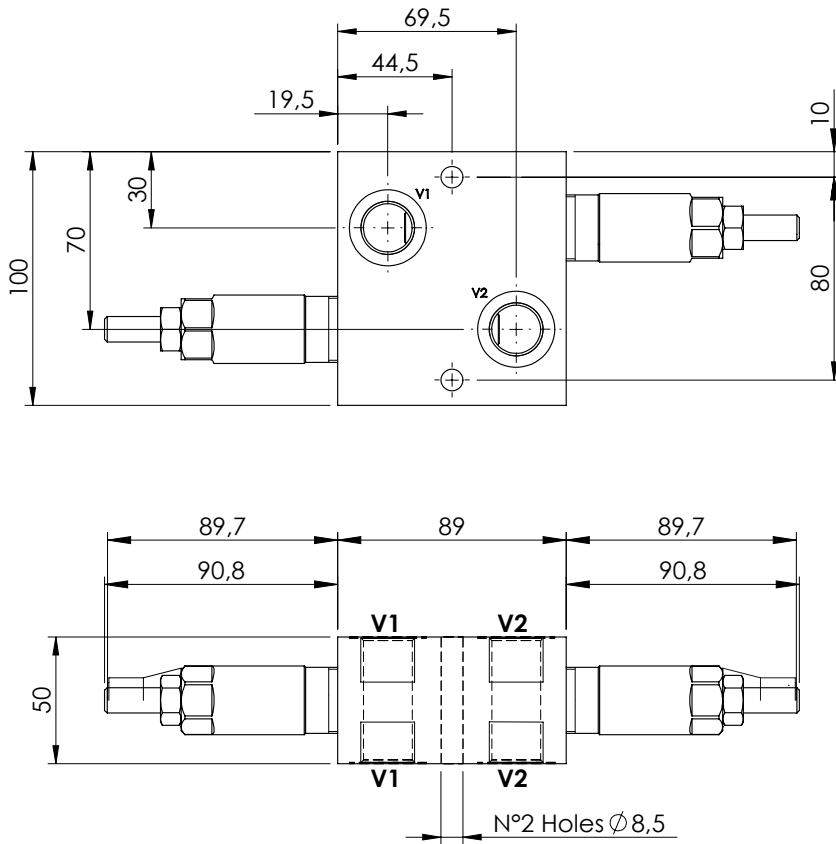

SPECIFICATIONS

Max. operating pressure:	350 bar
Rated flow:	80 l/min
Manifold:	Aluminium
Weight:	1,62 kg

SEALING CAP

Ordering code:
AT000021

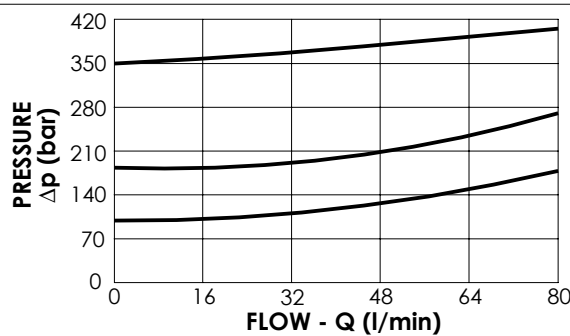
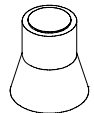

ORDERING CODES

Quick code	Description	Main ports size	Standard setting (bar, Q=5 l/min)	Adjust. range (bar)	Pressure increase (bar/turn)
MA000026	MADN-080-TLNR-HN-G12-N350	V1,V2 : G 1/2"	350	100-350	42
MA000025	MADN-080-TLNR-HN-G12-N200	V1,V2 : G 1/2"	200	60-210	24
MA000021	MADN-080-TLNR-HN-G12-N100	V1,V2 : G 1/2"	100	25-100	13

VALVES FOR MOTORS OR HYDRAULIC ACTUATORS



MADN-040-LLNR

DUAL CROSS OVER
ANTICAVITATION RELIEF

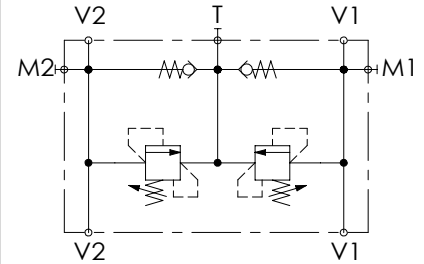
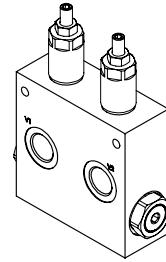
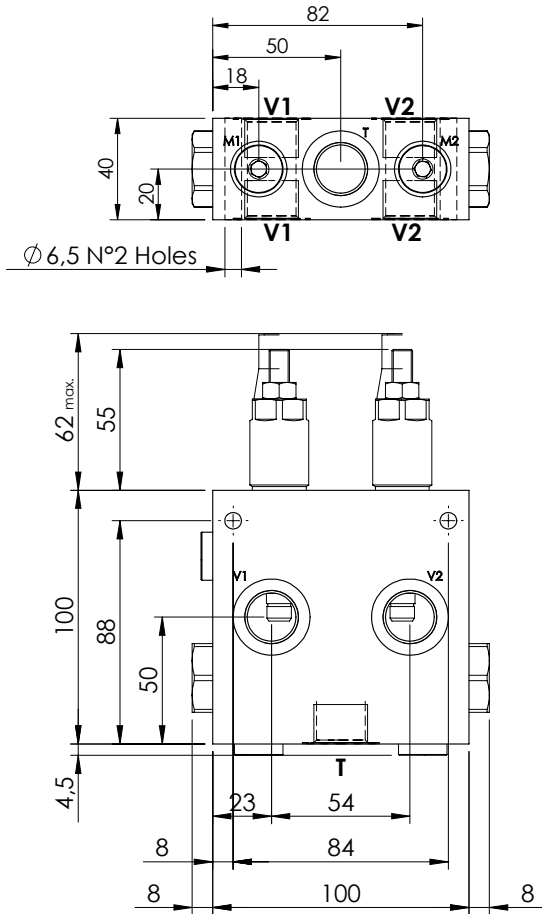

SPECIFICATIONS

Max. operating pressure:	210 bar
Rated flow:	40 l/min
Manifold:	Aluminium
Weight:	1,37 kg

SEALING CAP

Ordering code:
AT000020

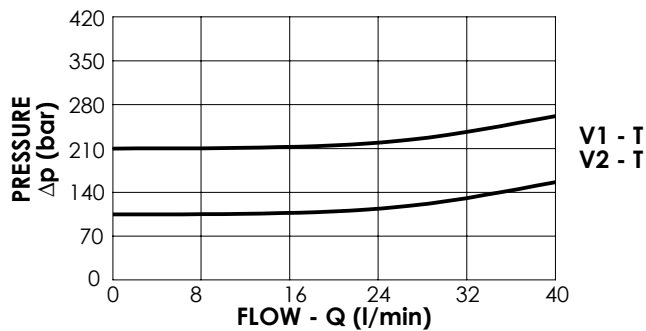
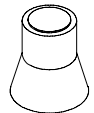

NOTES

Setting: at least 1.3 times the load induced pressure

ORDERING CODES

Quick code	Description	Main ports size	Standard setting (bar, Q=5 l/min)	Adjust. range (bar)	Pressure increase (bar/turn)
MA000054	MADN-040-LLNR-HN-G12-N200	V1,V2,T: G1/2" M1,M2: G1/4"	200	50-210	42
MA000055	MADN-040-LLNR-HN-G12-N100	V1,V2,T: G1/2" M1,M2: G1/4"	100	30-100	20

VALVES FOR MOTORS OR HYDRAULIC ACTUATORS

MADN-080-LLNR

DUAL CROSS OVER
ANTICAVITATION RELIEF

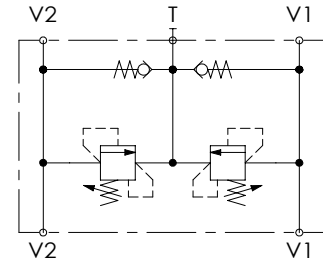
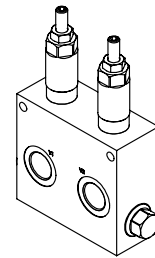
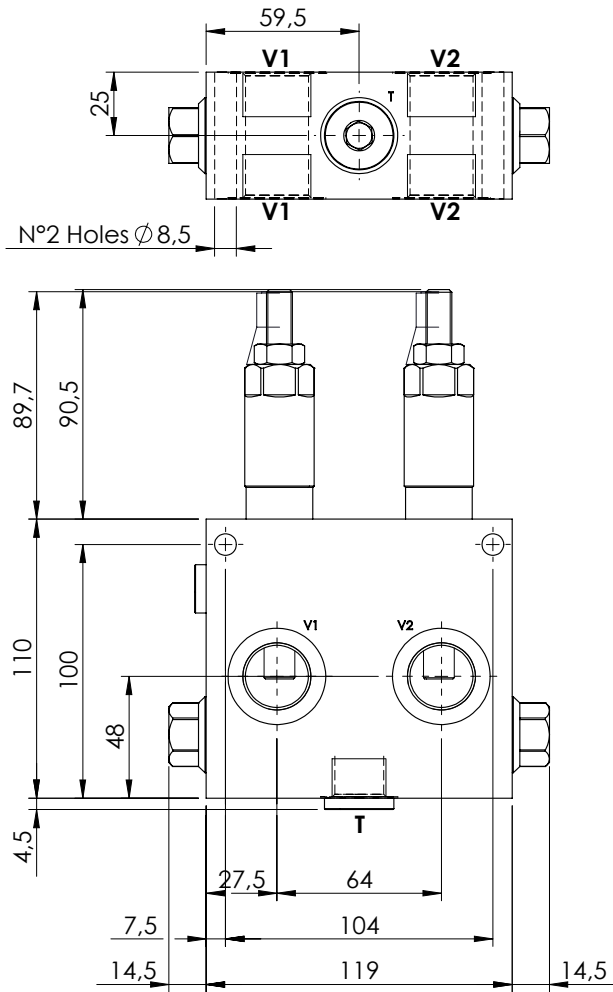

SPECIFICATIONS

Max. operating pressure:	250 bar
Rated flow:	80 l/min
Manifold:	Aluminium
Weight:	2,28 kg

SEALING CAP

Ordering code:
AT000021

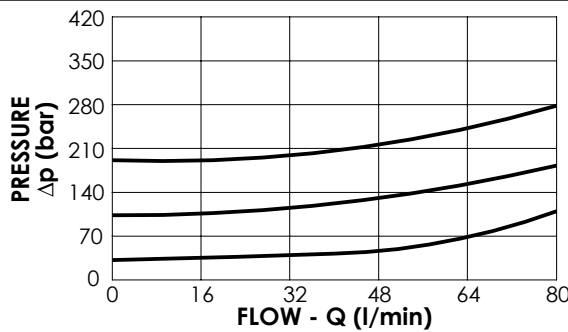
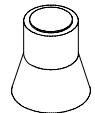

V1 - T
V2 - T

NOTES

Setting: at least 1.3 times the load induced pressure

ORDERING CODES

Quick code	Description	Main ports size	Standard setting (bar, Q=5 l/min)	Adjust. range (bar)	Pressure increase (bar/turn)
MA000018	MADN-080-LLNR-HN-G34-N200	V1,V2: G3/4" T: G1/2"	200	60-210	24
MA000023	MADN-080-LLNR-HN-G34-N100	V1,V2: G3/4" T: G1/2"	100	25-100	13
MA000024	MADN-080-LLNR-HN-G34-N050	V1,V2: G3/4" T: G1/2"	50	5-50	9

VALVES FOR MOTORS

MBDN-055-GLNR

COUNTERBALANCE

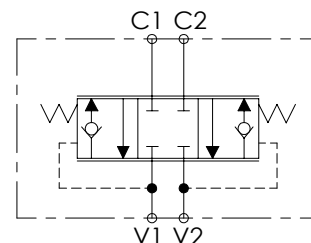
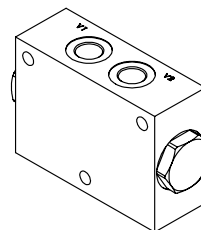
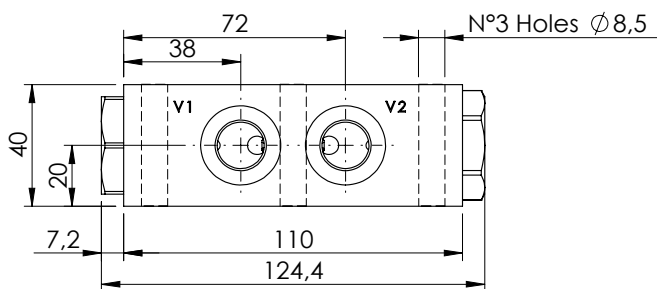
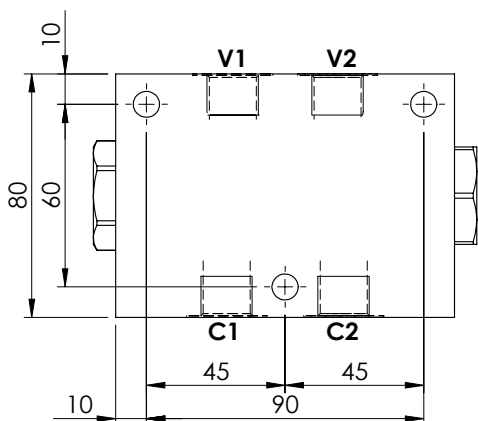
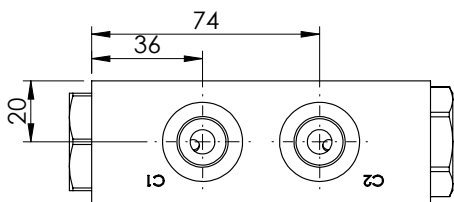

SPECIFICATIONS

Max. operating pressure:	350 bar
Rated flow:	55 l/min
Manifold:	Cast iron
Weight:	2,53 kg

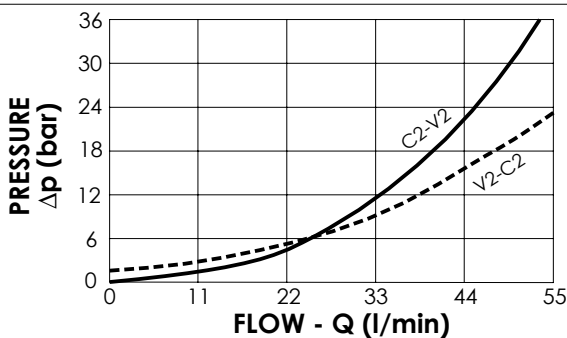

NOTES

Designed for traction control of small undercarriages

ORDERING CODES

Quick code	Description	Main ports size	Standard setting (bar, Q=5 l/min)	Adjust. range (bar)	Pressure increase (bar/turn)
MB000112	MBDN-055-GLNR-01-G38-N006	V1,V2,C1,C2 : G3/8"	6	Fixed setting	NO

VALVES FOR MOTORS

MBDN-055-GLSF

**COUNTERBALANCE
WITH BRAKE RELEASE**

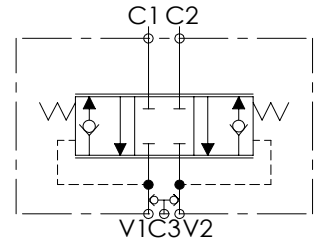
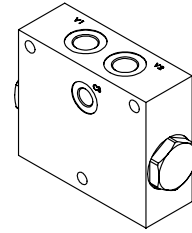
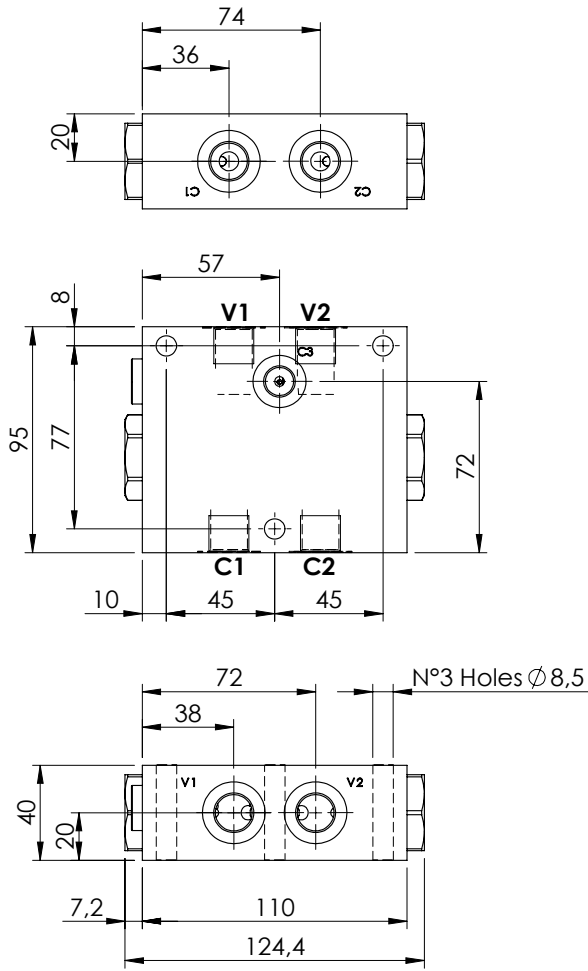

SPECIFICATIONS

Max. operating pressure:	350 bar
Rated flow:	55 l/min
Manifold:	Cast iron
Weight:	3,08 kg

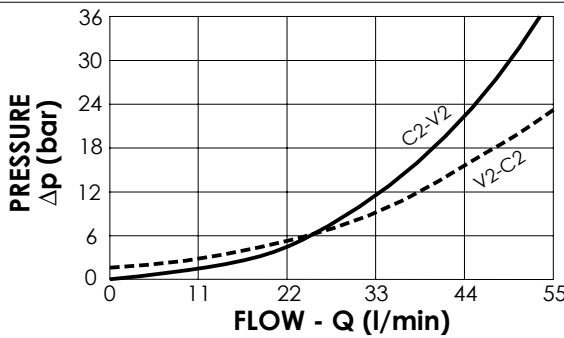

NOTES

Setting: at least 1.3 times the load induced pressure
Designed for traction control of small undercarriages

ORDERING CODES

Quick code	Description	Main ports size	Standard setting (bar, Q=5 l/min)	Adjust. range (bar)	Pressure increase (bar/turn)
MB000232	MBDN-055-GLSF-01-G38-N006	V1,V2,C1,C2 : G3/8" C3 : G1/4"	6	Fixed setting	NO

VALVES FOR MOTORS

MFLN-150-RFSR

**FLUSHING VALVE
FLANGEABLE TYPE**



O-Ring 18,64x3,53 - N70

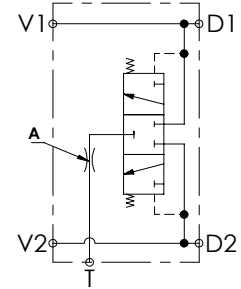
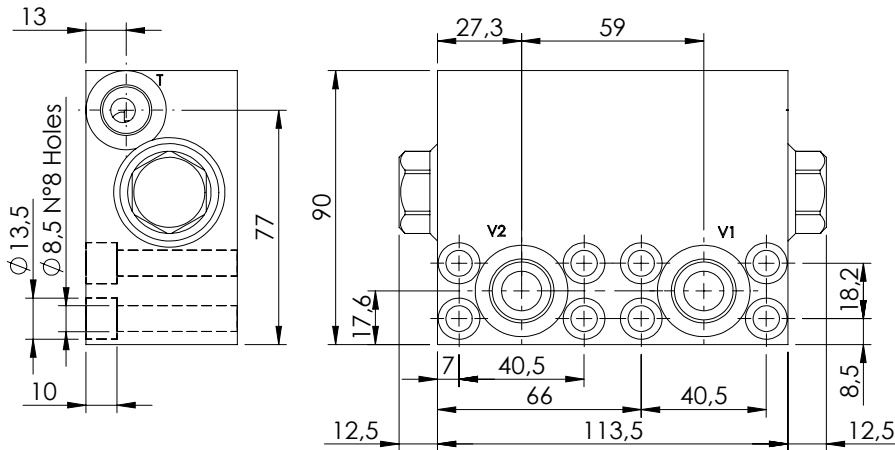
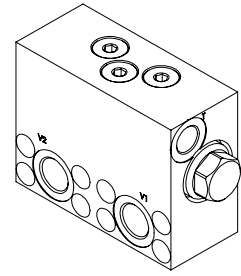

SPECIFICATIONS

Max. operating pressure:	420 bar
Rated flow:	150 l/min
Manifold:	Steel
Weight:	3,38 kg

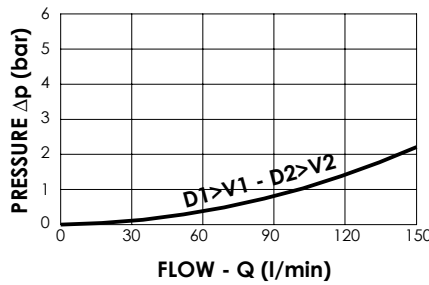
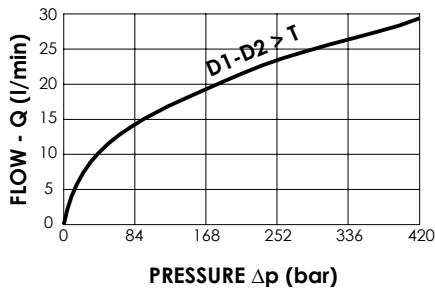

ORDERING CODES

Quick code	Description	Main ports size	Spool setting (bar)	A Orifice \varnothing	
MF000111	MFLN-150-RFSR-08-S12-N420	V1,V2:G1/2" D1,D2:1/2"SAE 6000 T: G3/8"	6	1,7	

VALVES FOR MOTORS

MFLN-300-RFSR

FLUSHING VALVE
FLANGEABLE TYPE

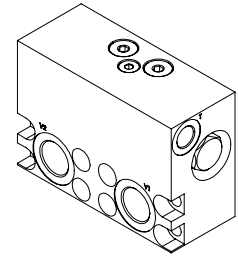

O-Ring 24,99x3,53 - N70

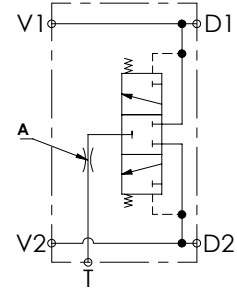
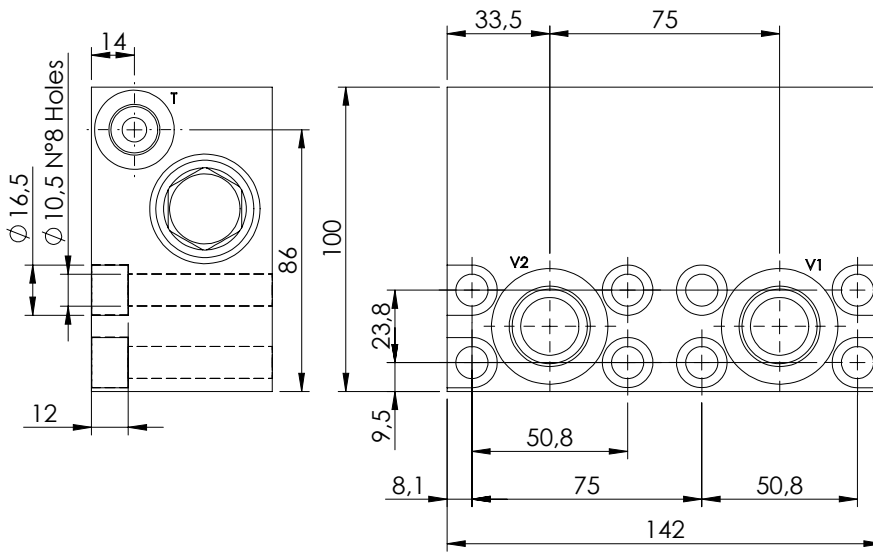
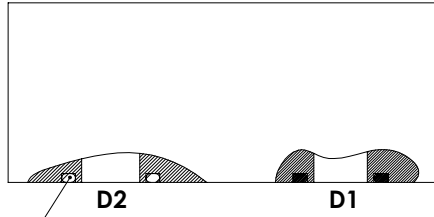

SPECIFICATIONS

Max. operating pressure:	420 bar
Rated flow:	200 l/min
Manifold:	Steel
Weight:	3,38 kg

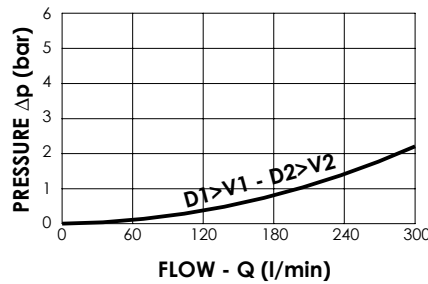
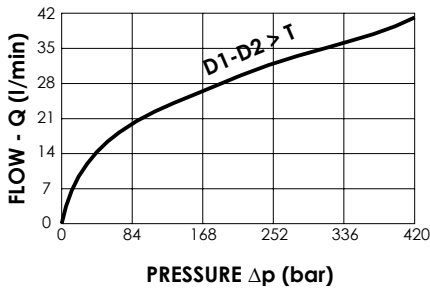

ORDERING CODES

Quick code	Description	Main ports size	Spool setting (bar)	A Orifice Ø	
MF000110	MFLN-200-RFSR-09-S34-N420	V1,V2:G3/4" D1,D2:3/4"SAE 6000 T: G3/8"	6	1,9	

VALVES FOR MOTORS

MFLN-500-RFSR

FLUSHING VALVE
FLANGEABLE TYPE

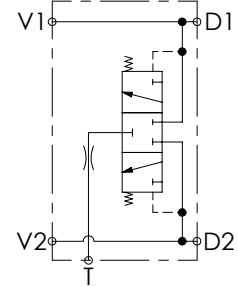
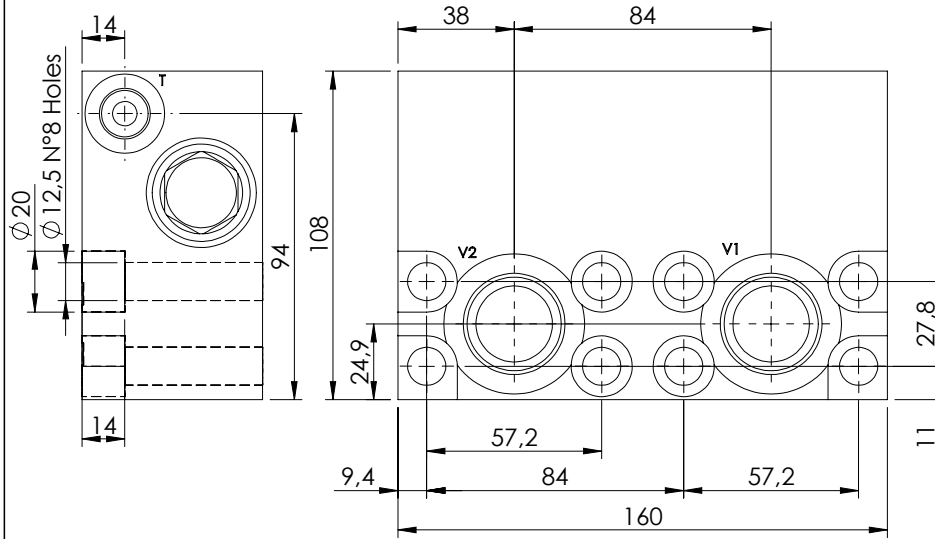
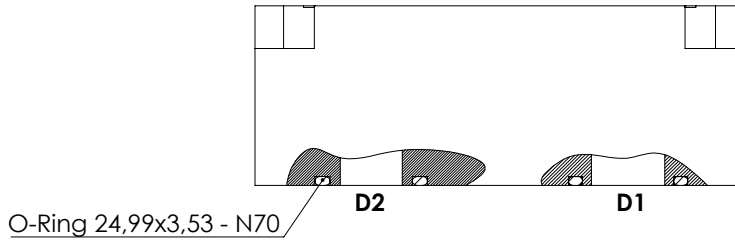
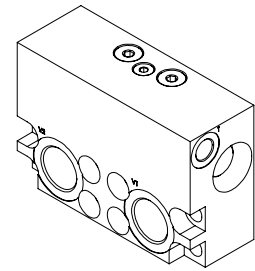

SPECIFICATIONS

Max. operating pressure:	420 bar
Rated flow:	500 l/min
Manifold:	Steel
Weight:	3,38 kg

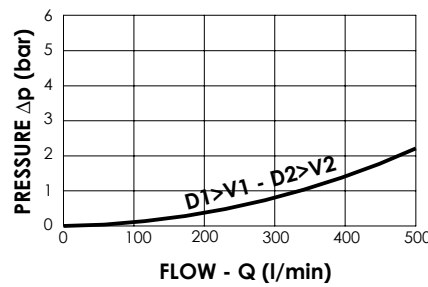
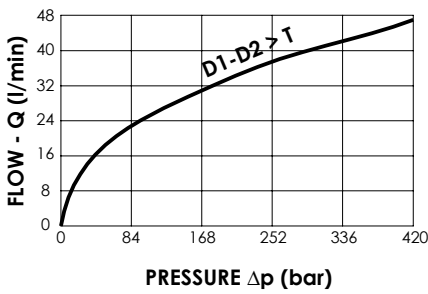

ORDERING CODES

Quick code	Description	Main ports size	Spool setting (bar)	A Orifice \varnothing
MF000109	MFLN-500-RFSR-13-S10-N420	V1,V2: G1" D1,D2: 1" SAE 6000 T: G3/8"	6	2,1

MBSN-060-ZMSF

**OVERCENTRE
WITH BRAKE RELEASE**

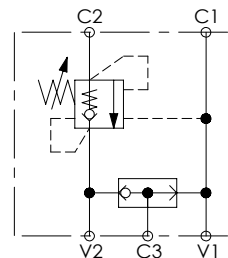
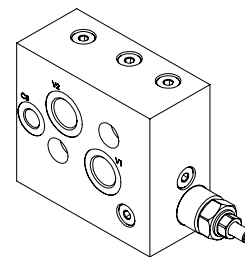
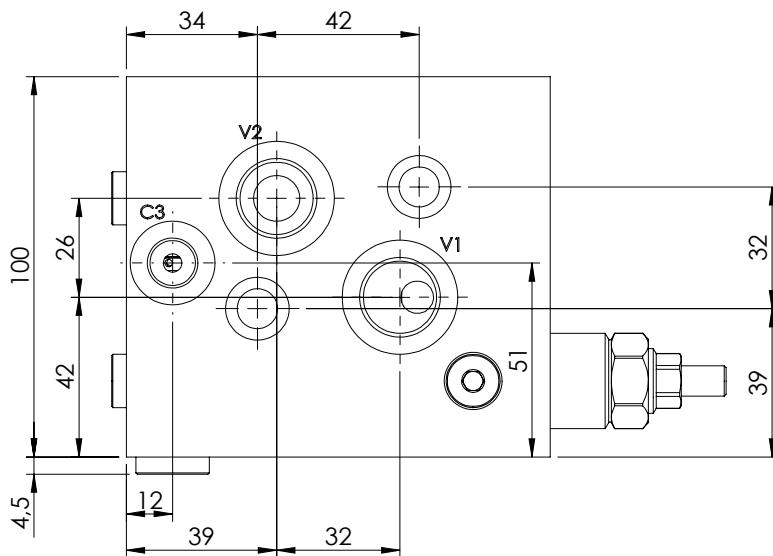

O-Ring 25,07x2,62-N70

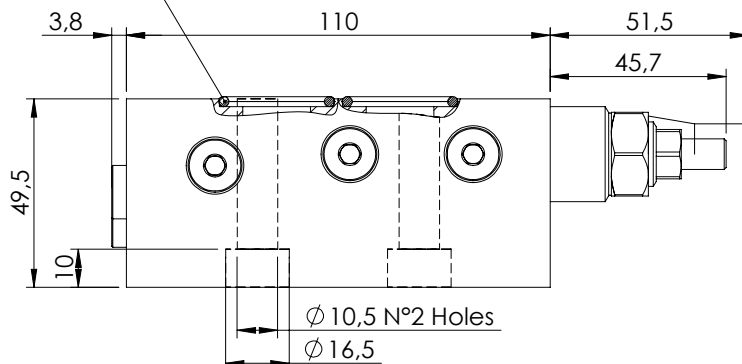

SPECIFICATIONS

Max. operating pressure:	350 bar
Rated flow:	60 l/min
Manifold:	Aluminium
Weight:	1,5 kg

SEALING CAP

Ordering code:
AT000020

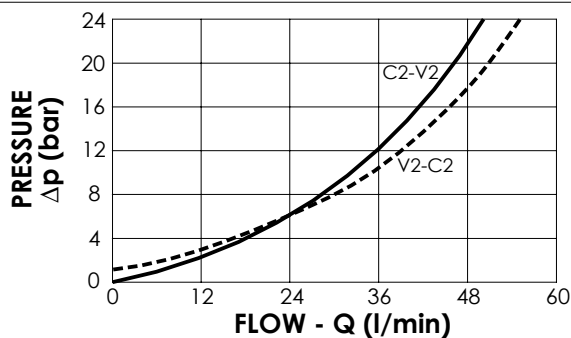
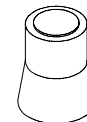

NOTES

Setting: at least 1.3 times the load induced pressure

Designed for DANFOSS motors OMS series

ORDERING CODES

Quick code	Description	Pilot ratio	Main ports size	Standard setting (bar, Q=5 l/min)	Adjust. range (bar)	Pressure increase (bar/turn)
MB001036	MBSN-060-ZMSF-04-G12-N350-NOMS	4,2:1	V1,V2: G1/2" C1,C2: OMS flange C3: G 1/4"	350	100-350	139
MB001058	MBSN-060-ZMSF-04-G12-N200-NOMS	4,2:1	V1,V2: G1/2" C1,C2: OMS flange C3: G 1/4"	200	60-210	62

VALVES FOR MOTORS

MBSN-060-ZMSF

**OVERCENTRE
WITH BRAKE RELEASE**

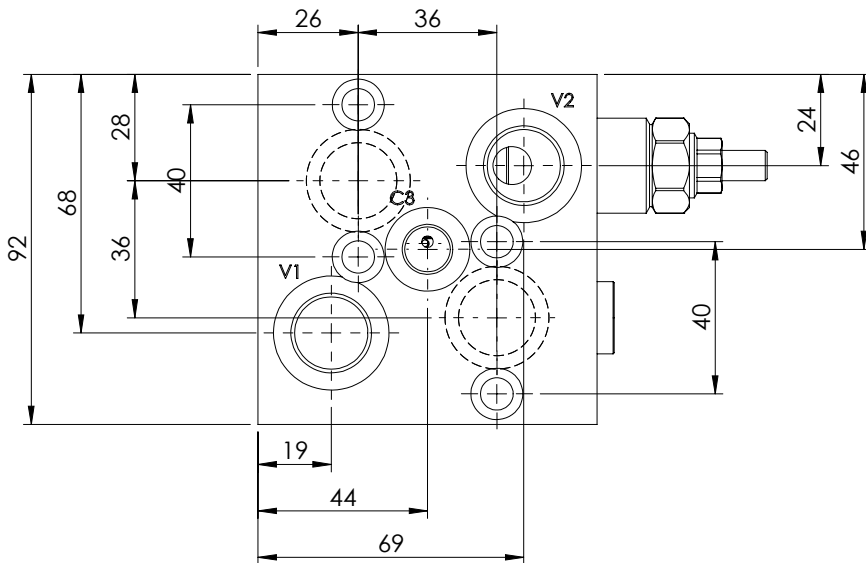

O-Ring 21,89x2,62 - N70

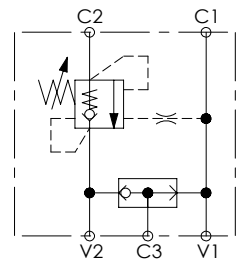
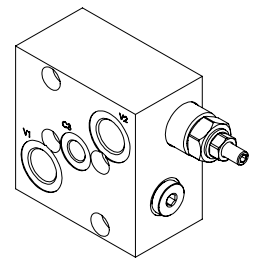
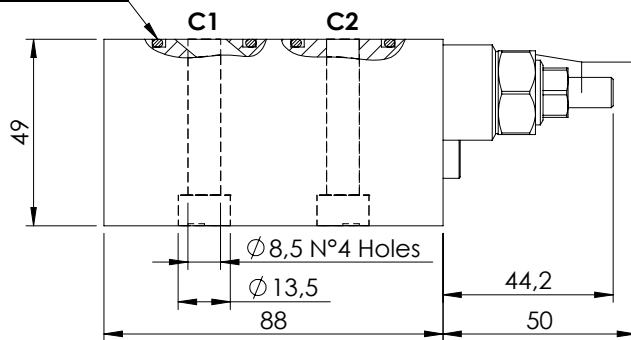

SPECIFICATIONS

Max. operating pressure:	350 bar
Rated flow:	60 l/min
Manifold:	Aluminium
Weight:	1,09 kg

SEALING CAP

Ordering code:
AT000020

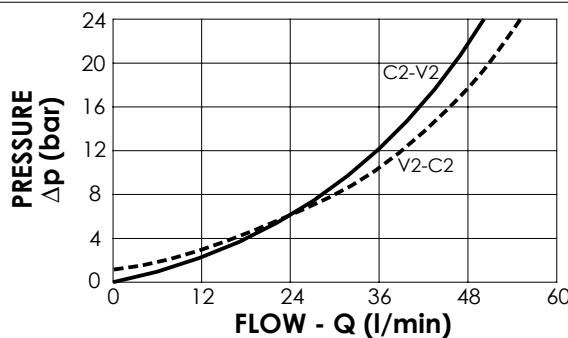
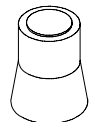

NOTES

Setting: at least 1.3 times the load induced pressure

Designed for DANFOSS motors OMP-OMR series

ORDERING CODES

Quick code	Description	Pilot ratio	Main ports size	Standard setting (bar, Q=5 l/min)	Adjust. range (bar)	Pressure increase (bar/turn)
MB000796	MBSN-060-ZMSF-04-G12-N350-NOMP	4,2:1	V1,V2: G1/2" C1,C2: OMP flange C3: G 1/4"	350	100-350	139
MB000795	MBSN-060-ZMSF-04-G12-N200-NOMP	4,2:1	V1,V2: G1/2" C1,C2: OMP flange C3: G 1/4"	200	60-210	62

VALVES FOR MOTORS

MBDN-060-ALSF

**DOUBLE ACTING WITH
BRAKE RELEASE**

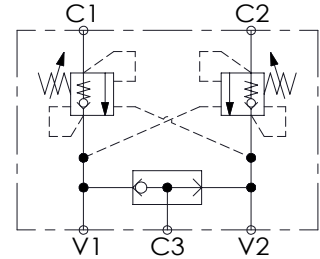
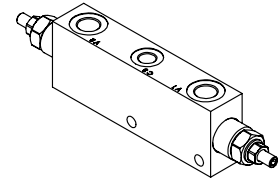
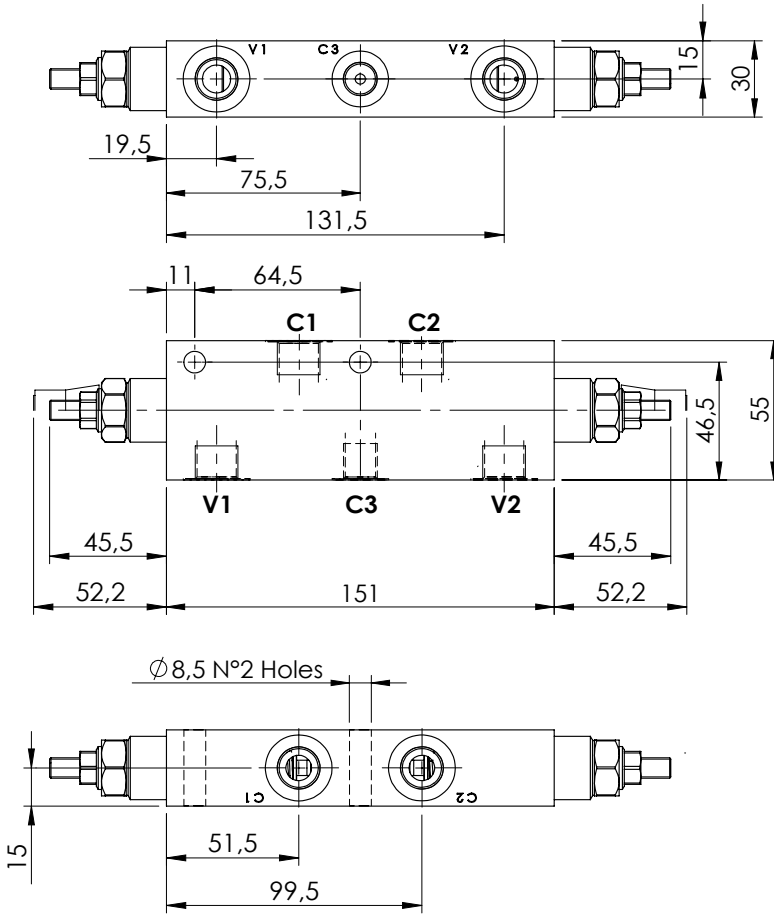

SPECIFICATIONS

Max. operating pressure:	350 bar
Rated flow:	60 l/min
Manifold:	Steel
Weight:	1,89 kg

SEALING CAP

Ordering code:
AT000020

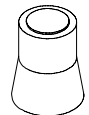

NOTES

Setting: at least 1.3 times the load induced pressure

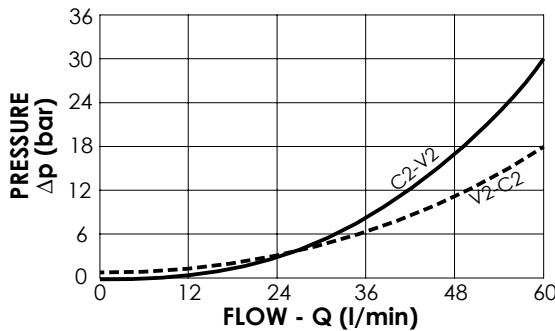

ORDERING CODES

Quick code	Description	Pilot ratio	Main ports size	Standard setting (bar, Q=5 l/min)	Adjust. range (bar)	Pressure increase (bar/turn)
MB000528	MBDN-060-ALSF-04-G38-N350	4,2:1	V1,V2: G3/8" C1,C2: G3/8" C3:G1/4"	350	100-350	138
MB000529	MBDN-060-ALSF-04-G38-N200	4,2:1	V1,V2: G3/8" C1,C2: G3/8" C3:G1/4"	200	60-210	62
MB000704	MBDN-060-ALSF-11-G38-N250	11:1	V1,V2: G3/8" C1,C2: G3/8" C3:G1/4"	250	60-250	56

VALVES FOR MOTORS

MBDN-060-ALSF

**DOUBLE ACTING WITH
BRAKE RELEASE**

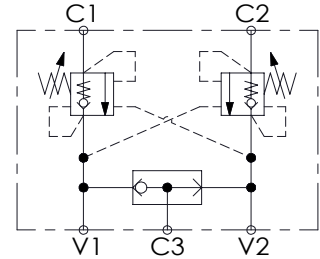
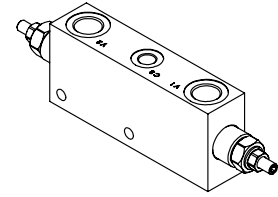
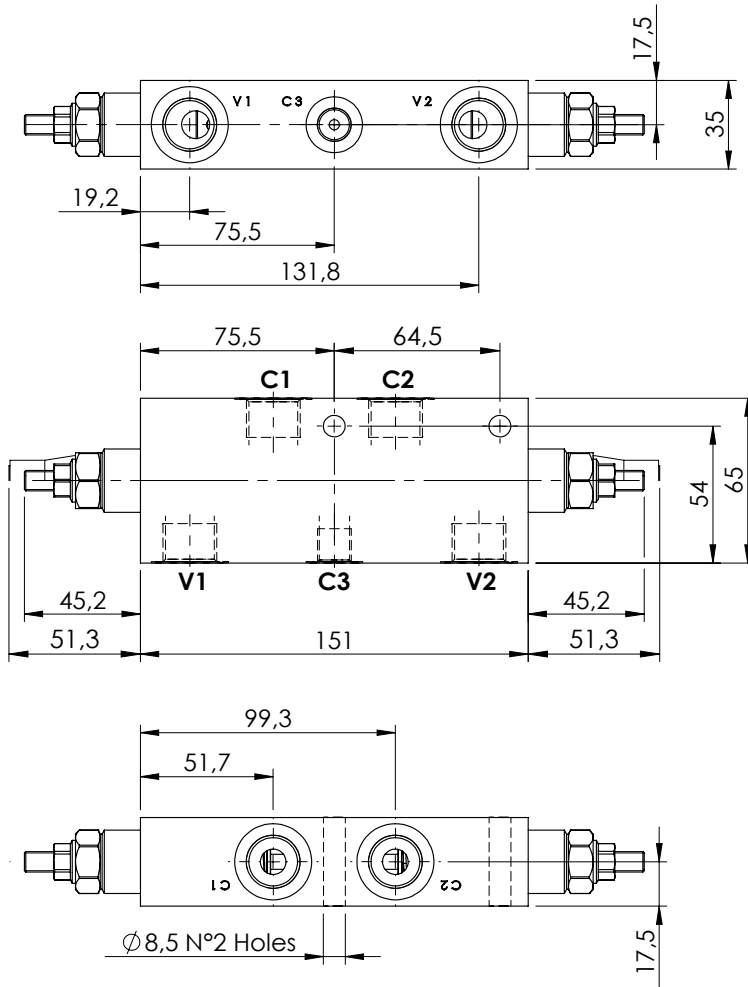

SPECIFICATIONS

Max. operating pressure:	350 bar
Rated flow:	60 l/min
Manifold:	Steel
Weight:	2,53 kg

SEALING CAP

Ordering code:
AT000020

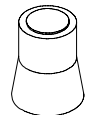

NOTES

Setting: at least 1.3 times the load induced pressure

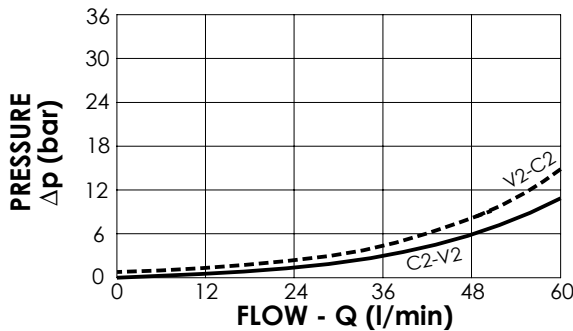

ORDERING CODES

Quick code	Description	Pilot ratio	Main ports size	Standard setting (bar, Q=5 l/min)	Adjust. range (bar)	Pressure increase (bar/turn)
MB000021	MBDN-060-ALSF-11-G12-N350	11:1	V1,V2: G1/2" C1,C2: G1/2" C3:G1/4"	350	100-350	161
MB000465	MBDN-060-ALSF-11-G12-N250	11:1	V1,V2: G1/2" C1,C2: G1/2" C3:G1/4"	250	60-250	69
MB000466	MBDN-060-ALSF-04-G12-N350	4,2:1	V1,V2: G1/2" C1,C2: G1/2" C3:G1/4"	350	100-350	139
MB000363	MBDN-060-ALSF-04-G12-N200	4,2:1	V1,V2: G1/2" C1,C2: G1/2" C3:G1/4"	200	60-210	62

VALVES FOR MOTORS

MBDN-060-ZMSF

DOUBLE ACTING WITH BRAKE RELEASE

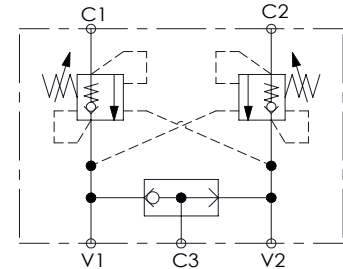
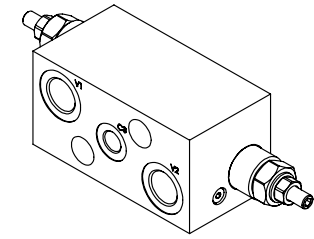
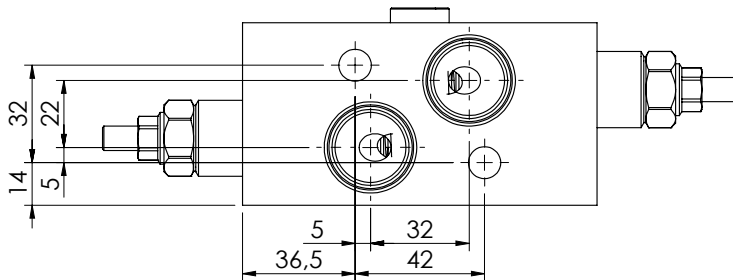
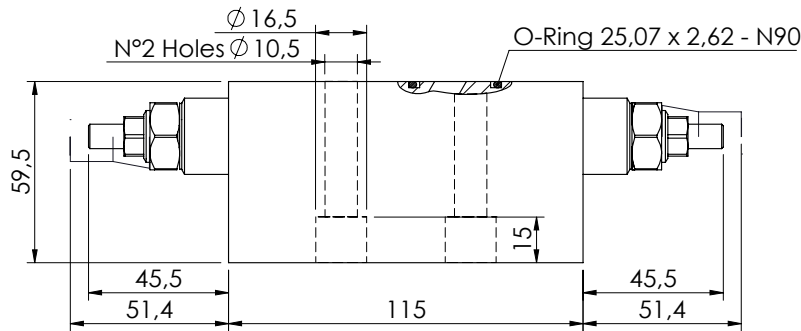
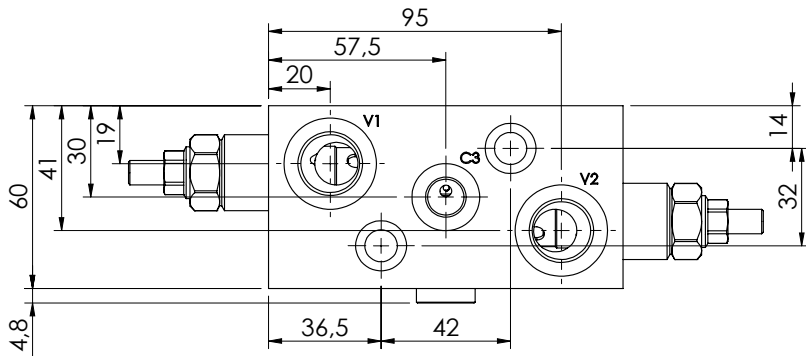

SPECIFICATIONS

Max. operating pressure:	250 bar
Rated flow:	60 l/min
Manifold:	Aluminium
Weight:	1,25 kg

SEALING CAP

Ordering code:
AT000020

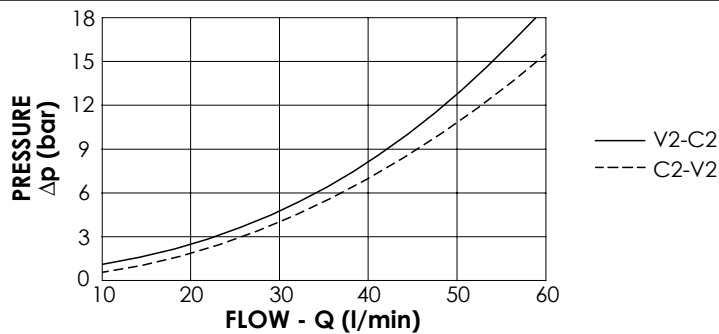
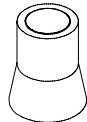

NOTES

Designed for OMS motors

ORDERING CODES

Quick code	Description	Pilot ratio	Main ports size	Standard setting (bar, Q=5 l/min)	Adjust. range (bar)	Pressure increase (bar/turn)
MB000908	MBDN-060-LMSF-11-G12-N250	11:1	V1, V2: G1/2" C1, C2: Ø9 C3: G1/4"	250	100-420	69

VALVES FOR MOTORS

MBDN-060-ZMNR

**OVERCENTRE
WITH BRAKE RELEASE**

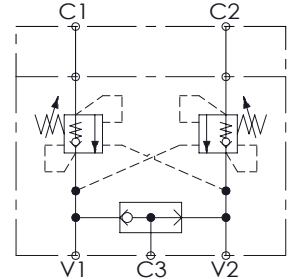
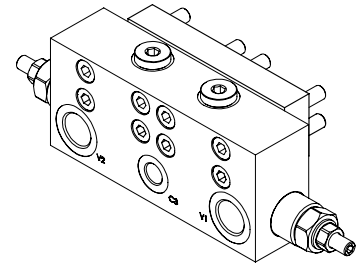
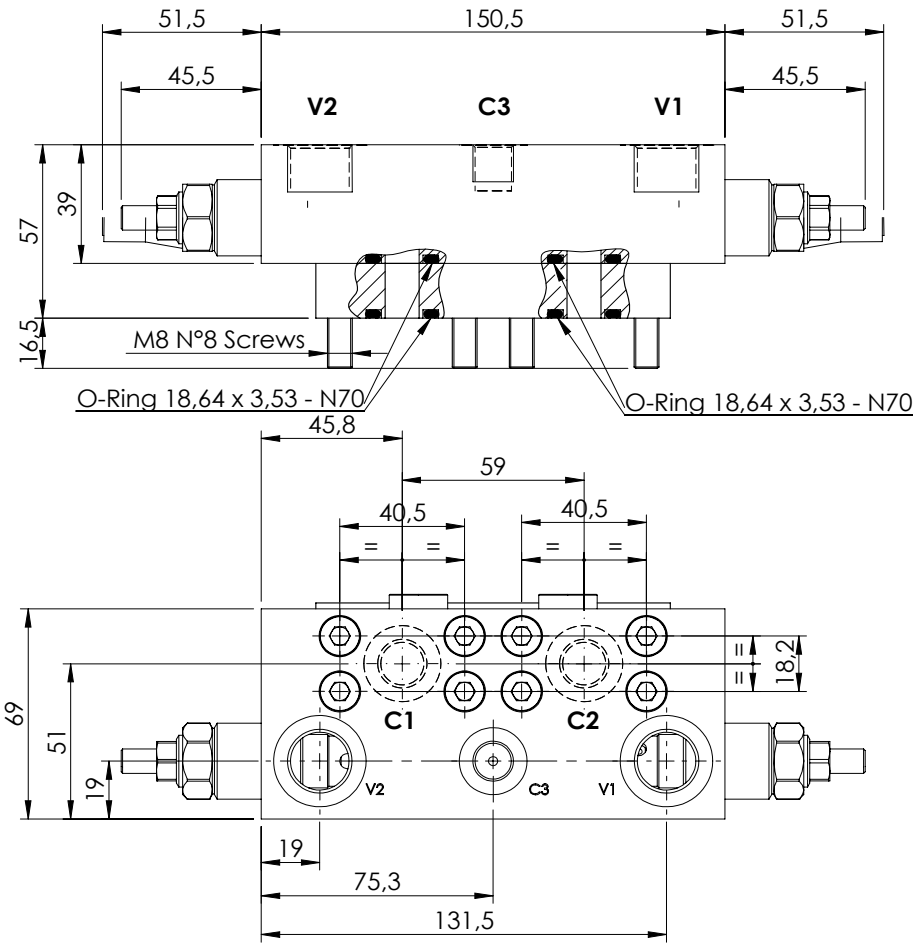

SPECIFICATIONS

Max. operating pressure:	250 bar
Rated flow:	60 l/min
Manifold:	Anodized Aluminium
Weight:	2 kg

SEALING CAP

Ordering code:
AT000020

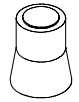

NOTES

Setting: at least 1.3 times the load induced pressure

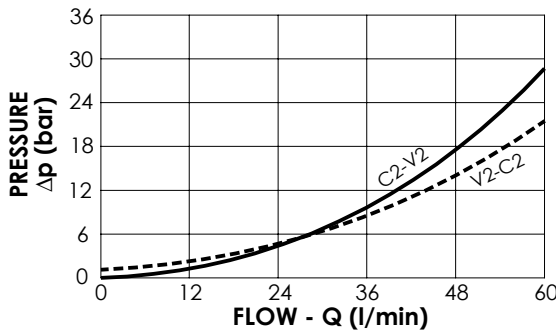

ORDERING CODES

Quick code	Description	Pilot ratio	Main ports size	Standard setting (bar, Q=5 l/min)	Adjust. range (bar)	Pressure increase (bar/turn)
MB000195	MBDN-060-ZMNR-11-G12-N250	11:1	V1,V2: G 1/2" C3: G 1/4" C1,C2: 1/2" SAE 6000	250	60-250	69

VALVES FOR MOTORS

MBDN-060-ABSF

DOUBLE ACTING WITH BRAKE RELEASE

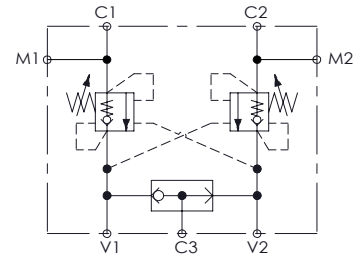
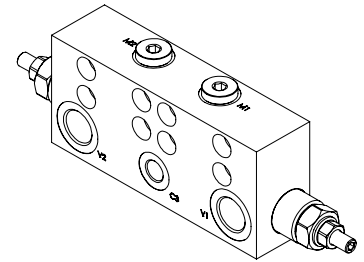
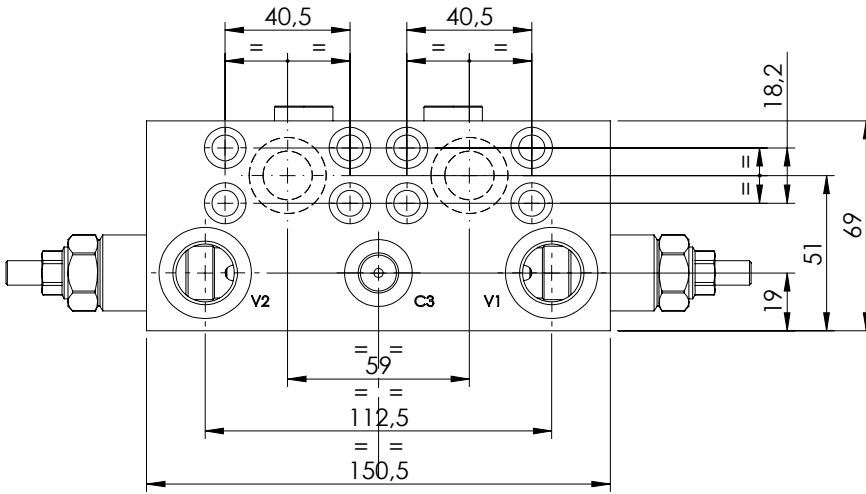

SPECIFICATIONS

Max. operating pressure:	350 bar
Rated flow:	60 l/min
Manifold:	Steel
Weight:	2,91 kg

SEALING CAP

Ordering code:
AT000020

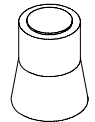

NOTES

Setting: at least 1.3 times the load induced pressure

Designed for REXROTH motors A2FE-28-32 series

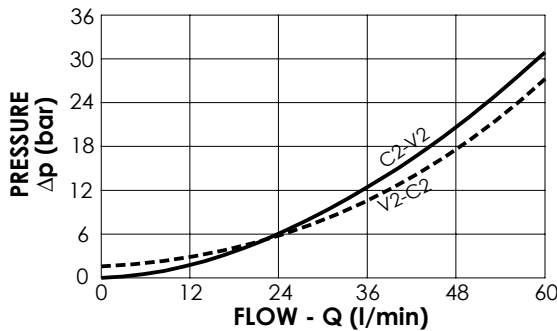
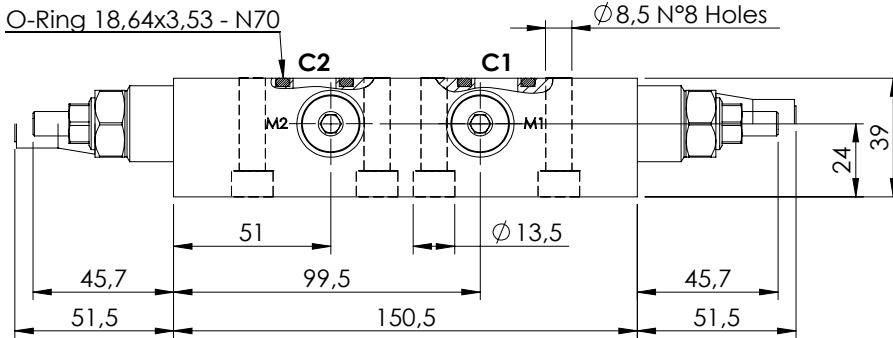

ORDERING CODES

Quick code	Description	Pilot ratio	Main ports size	Standard setting (bar, Q=5 l/min)	Adjust. range (bar)	Pressure increase (bar/turn)
MB000868	MBDN-060-ABSF-04-G12-N350	4:1	V1,V2: G1/2" C3,M1,M2: G1/4" C1,C2: Ø14	170	100-350	139

VALVES FOR MOTORS

MBDN-060-LMSF

**OVERCENTRE
WITH BRAKE RELEASE**

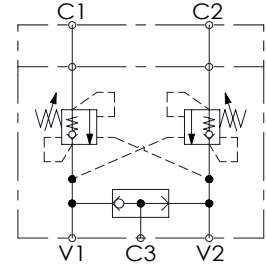
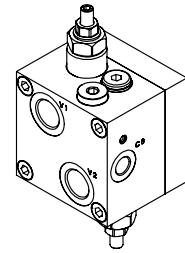
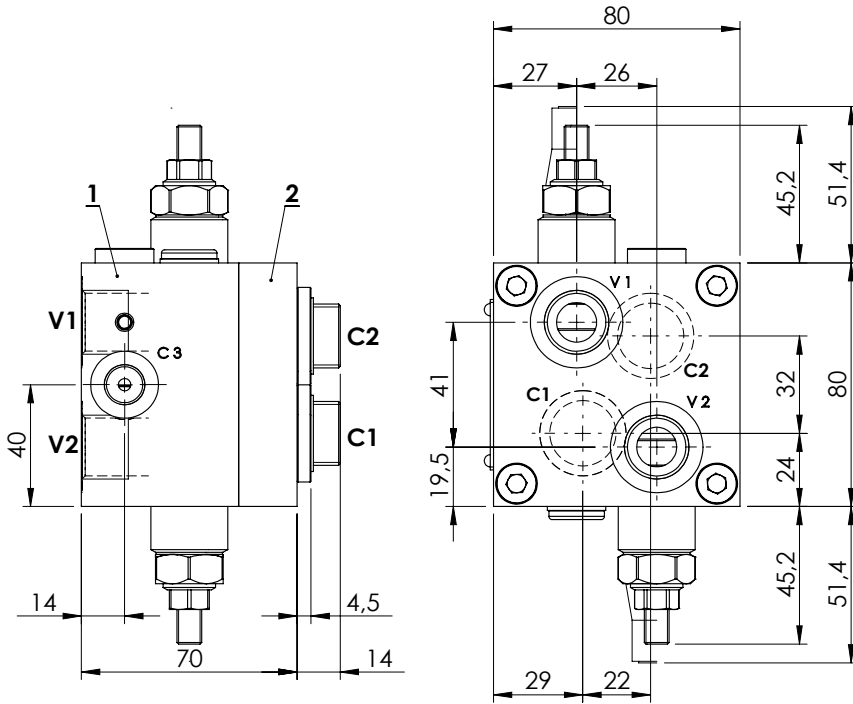

SPECIFICATIONS

Max. operating pressure:	250 bar
Rated flow:	60 l/min
Manifold:	Anodized Aluminium
Weight:	2,07 kg

SEALING CAP

Ordering code:
AT000020

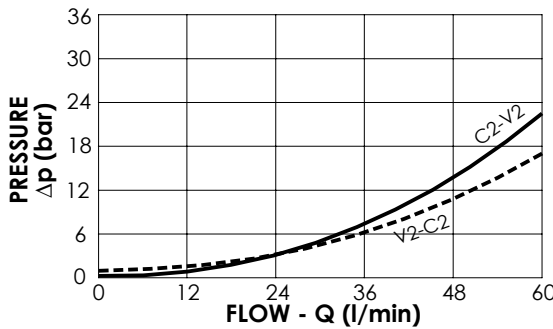
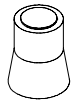

NOTES

Setting: at least 1.3 times the load induced pressure

Designed for OMS motors

Valve composed by:
1.MB000520
2.MP000012

ORDERING CODES

Quick code	Description	Pilot ratio	Main ports size	Standard setting (bar, Q=5 l/min)	Adjust. range (bar)	Pressure increase (bar/turn)
MB000036	MBDN-060-LMSF-04-G12-N200-NOMS	4,2:1	V1,V2: G 1/2" C1,C2: OMS flange C3: G 1/4"	200	60-210	62

VALVES FOR MOTORS

MBDN-060-LMSF

**OVERCENTRE
WITH BRAKE RELEASE**

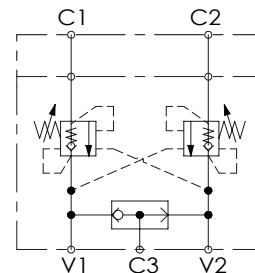
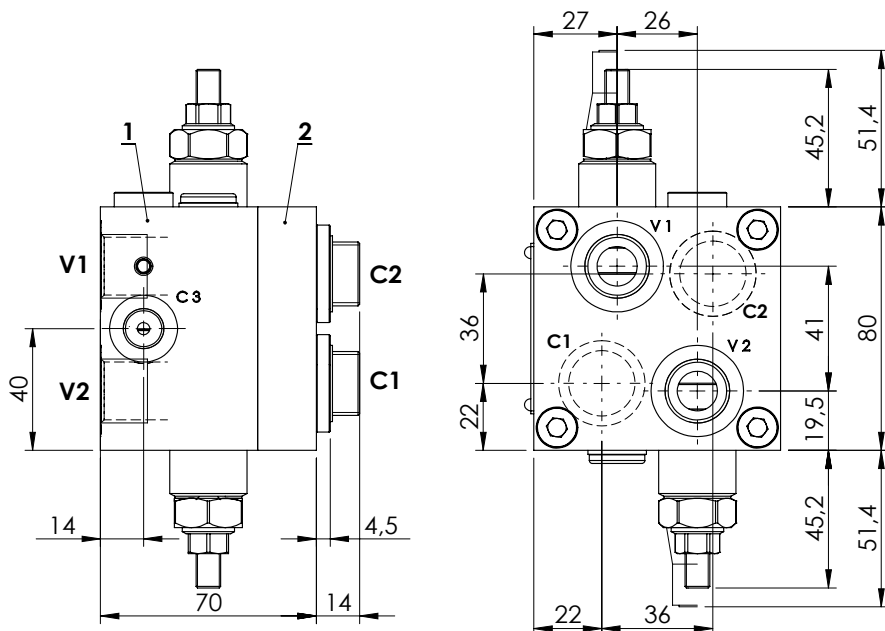
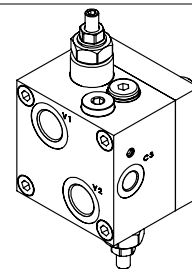

SPECIFICATIONS

Max. operating pressure:	250 bar
Rated flow:	60 l/min
Manifold:	Anodized Aluminium
Weight:	2,07 kg

SEALING CAP

Ordering code:
AT000020

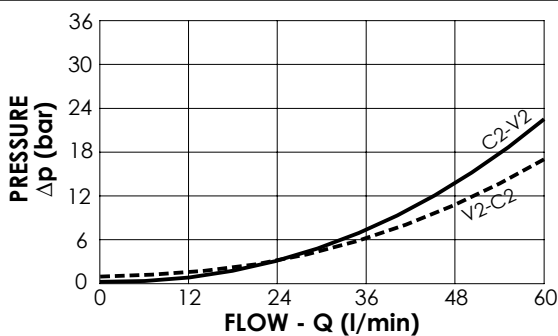
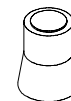

NOTES

Setting: at least 1.3 times the load induced pressure

Designed for OMP motors

Valve composed by:
1.MB000520
2.MP000013

ORDERING CODES

Quick code	Description	Pilot ratio	Main ports size	Standard setting (bar, Q=5 l/min)	Adjust. range (bar)	Pressure increase (bar/turn)
MB000208	MBDN-060-LMSF-04-G12-N200-NOMP	4,2:1	V1,V2: G 1/2" C1,C2: OMP flange C3: G1/4"	200	60-210	62

VALVES FOR MOTORS

MBDN-060-AMSF

**OVERCENTRE
WITH BRAKE RELEASE**

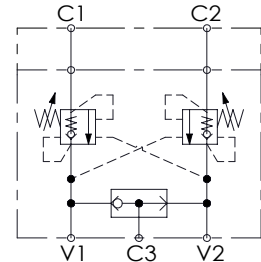
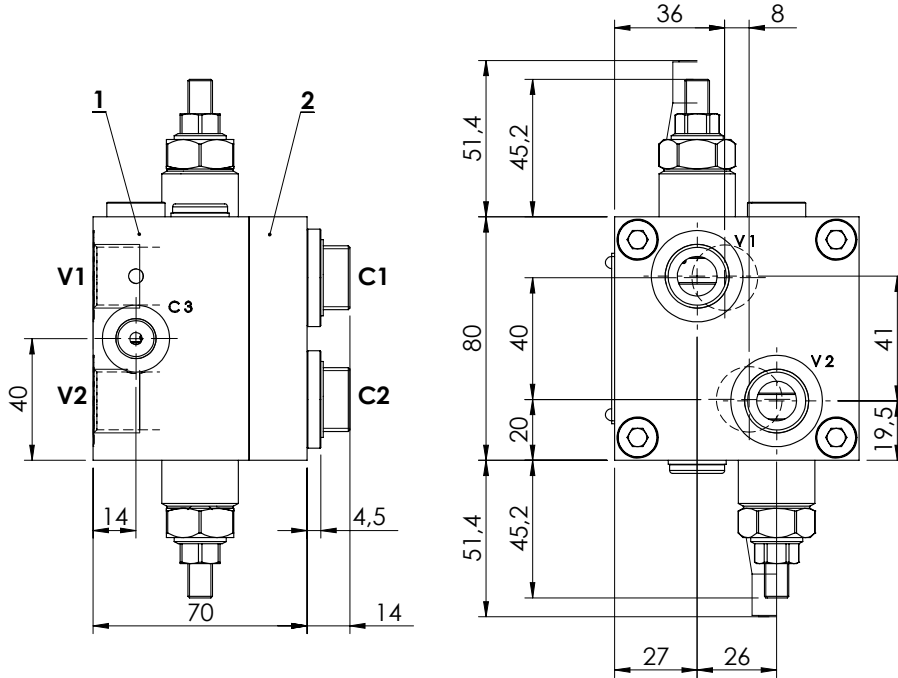
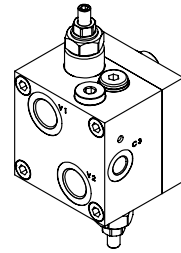

SPECIFICATIONS

Max. operating pressure:	350 bar
Rated flow:	60 l/min
Manifold:	Steel
Weight:	3,44 kg

SEALING CAP

Ordering code:
AT000020

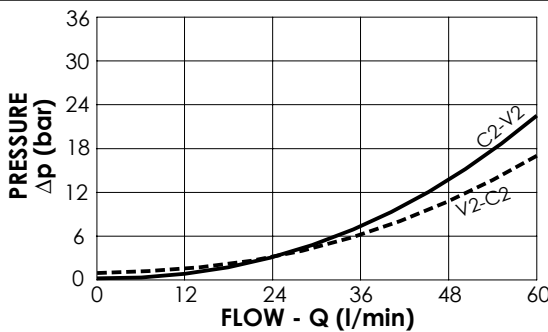
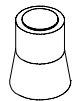

NOTES

Setting: at least 1.3 times the load induced pressure
Designed for SAM HYDRAULIK BR motors
Valve composed by:
1.MB000619
2.MP000034

ORDERING CODES

Quick code	Description	Pilot ratio	Main ports size	Standard setting (bar, Q=5 l/min)	Adjust. range (bar)	Pressure increase (bar/turn)
MB000317	MBDN-060-AMSF-04-G12-N200-SH BR	4,2:1	V1, V2: G 1/2" C1, C2: Sam Hydraulik flange C3: G 1/4"	200	60-210	62

VALVES FOR MOTORS

MBDN-060-AMSF

**OVERCENTRE
WITH BRAKE RELEASE**

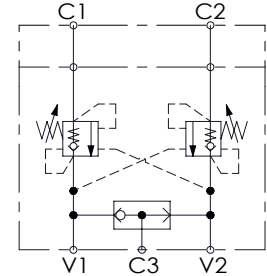
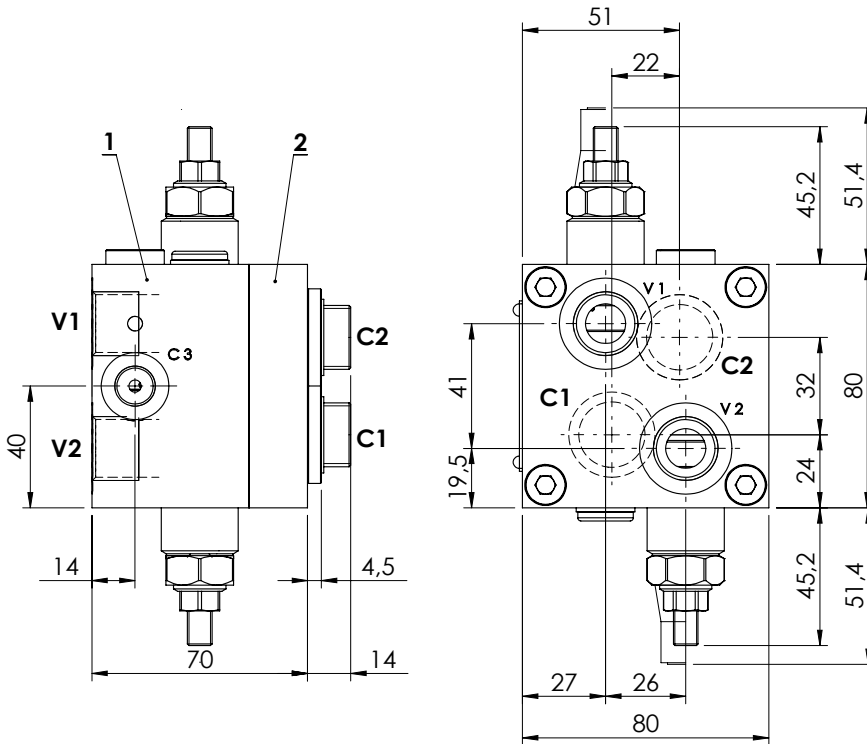
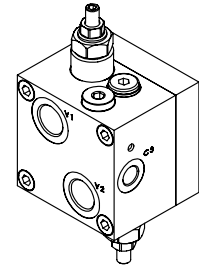

SPECIFICATIONS

Max. operating pressure:	350 bar
Rated flow:	60 l/min
Manifold:	Steel
Weight:	3,44 kg

SEALING CAP

Ordering code:
AT000020

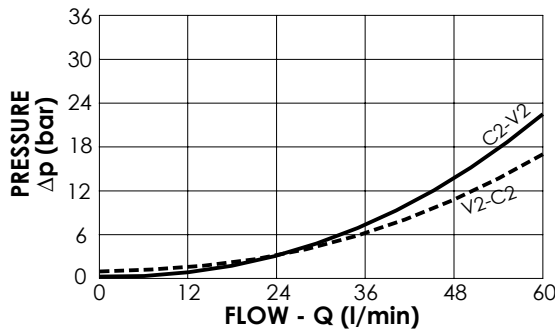
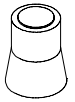

NOTES

Setting: at least 1.3 times the load induced pressure

Designed for
SAM HYDRAULIC HR/OMS motors

Valve composed by:
1.MB000619
2.MP000030

ORDERING CODES

Quick code	Description	Pilot ratio	Main ports size	Standard setting (bar, Q=5 l/min)	Adjust. range (bar)	Pressure increase (bar/turn)
MB000319	MBDN-060-AMSF-04-G12-N200-SH HR	4,2:1	V1, V2: G 1/2" C1, C2: Sam Hydraulic HR /OMS C3: G 1/4"	200	60-210	62

VALVES FOR MOTORS

MBDN-060-AMSR

**OVERCENTRE
WITH BRAKE RELEASE**

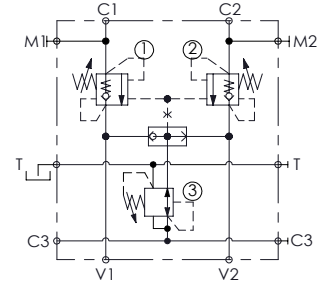
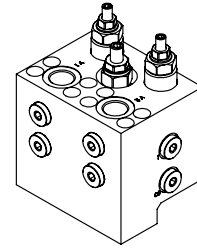
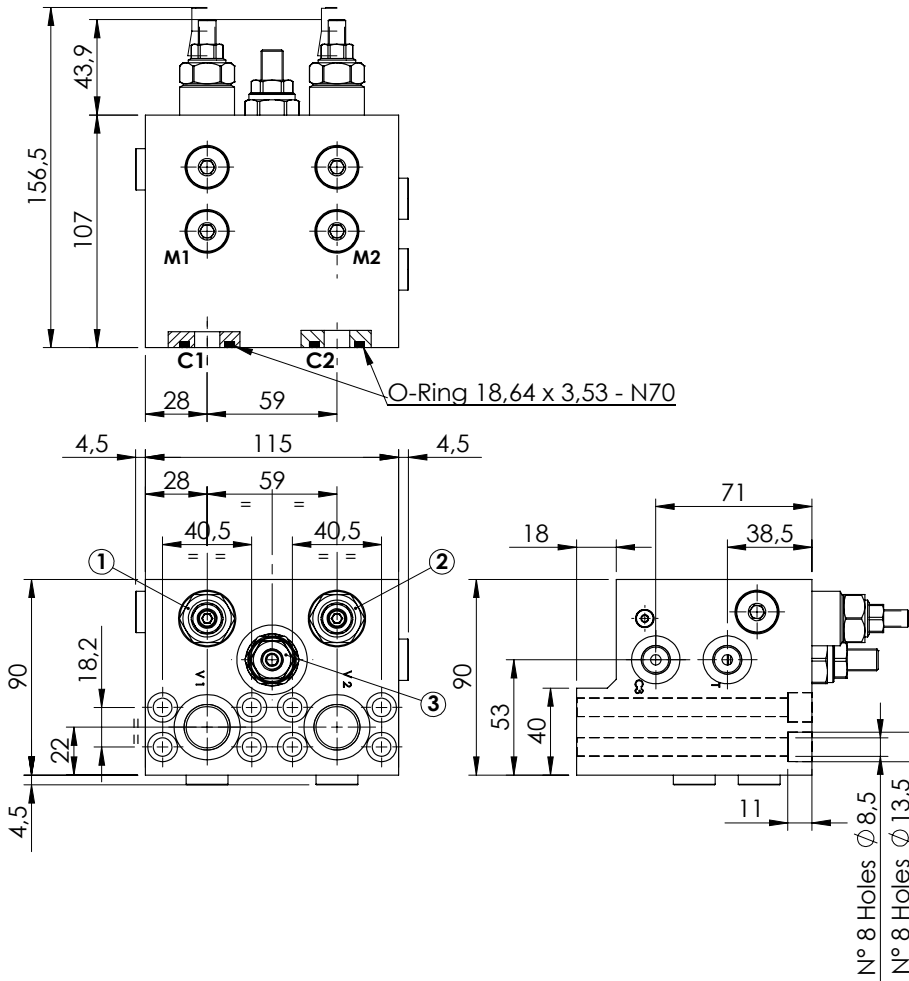

SPECIFICATIONS

Max. operating pressure:	420 bar
Rated flow:	60 l/min
Manifold:	Steel
Weight:	7,04 kg

SEALING CAP

Ordering code:
AT000020

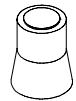

NOTES

Setting: at least 1.3 times the load induced pressure
Designed for REXROTH A2FE 28-32 motors

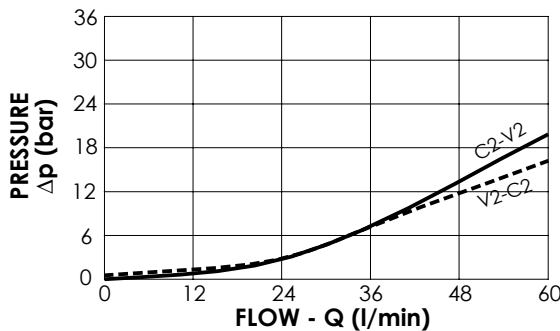

ORDERING CODES

Quick code	Description	Pilot ratio	Main ports size	Standard setting (bar, Q=5 l/min)	Adjust. range (bar)	Pressure increase (bar/turn)
MB000483	MBDN-060-AMSR-11-S12-N420	11:1	V1,V2:G1/2" C1,C2:1/2 SAE 6000 C3,T,M1,M2:G1/4"	①②:350 ③:50	①②:80-350 ③:10-60	①②:161 ③:6

VALVES FOR MOTORS

MBDN-100-AMSR

OVERCENTRE WITH BRAKE RELEASE

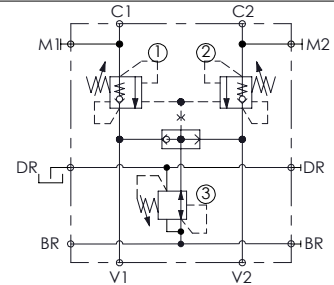
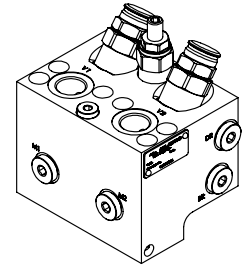
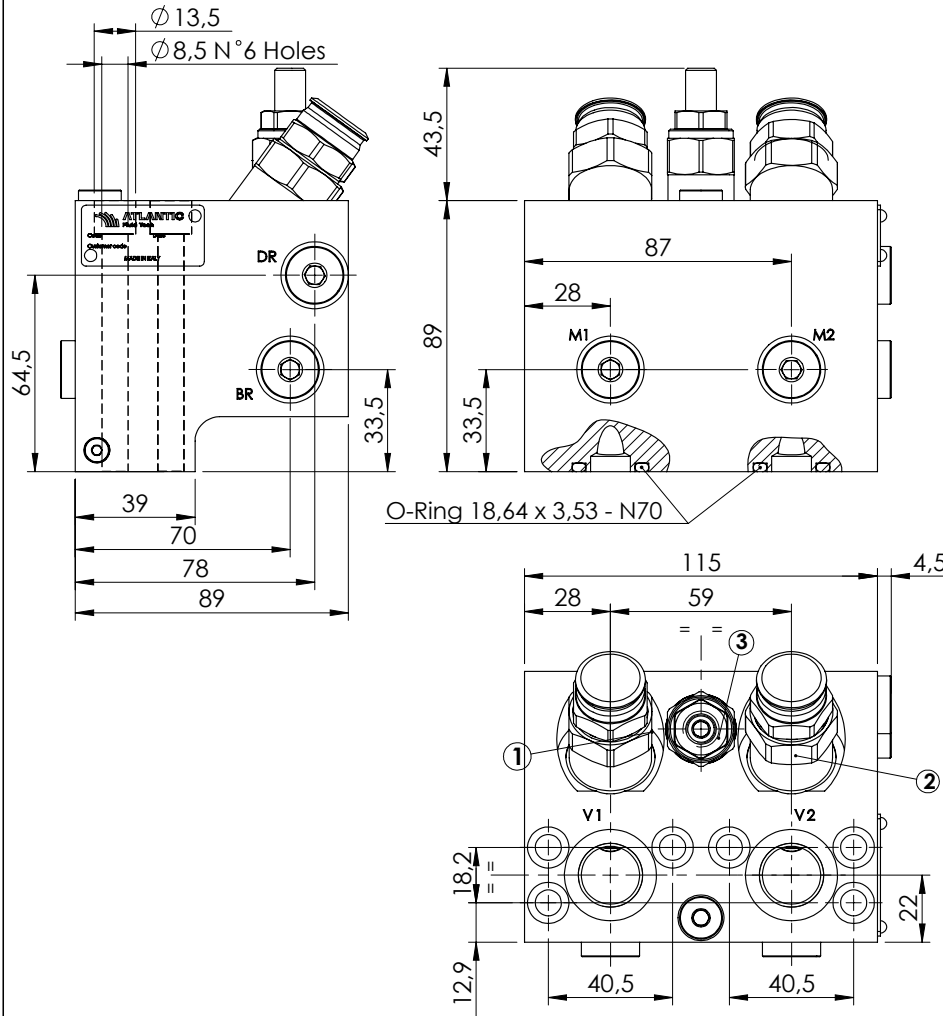

SPECIFICATIONS

Max. operating pressure:	420 bar
Rated flow:	100 l/min
Manifold:	Steel
Weight:	5,83 kg

SEALING CAP

Ordering code:
PT000243

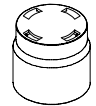

NOTES

Setting: at least 1.3 times the load induced pressure
Designed for REXROTH A2FE 28-32 motors

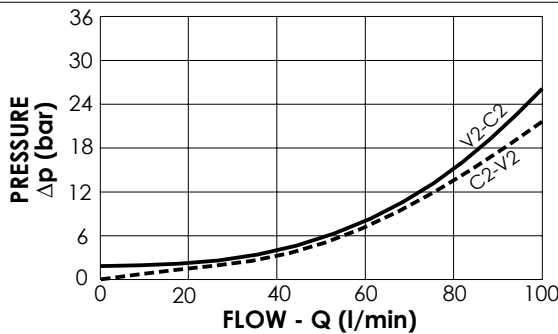

ORDERING CODES

Quick code	Description	Pilot ratio	Main ports size	Standard setting (bar, Q=5 l/min)	Adjust. range (bar)	Pressure increase (bar/turn)
MB000484	MBDN-100-AMSR-04-S12-N420	3,8:1	V1,V2: G1/2" C1,C2: 1/2" SAE 6000 DR,BR,M1,M2: G1/4"	①②:350 ③:40	①②:100-350 ③:10-60	①②:118 ③:6
MB000766	MBDN-100-AMSR-08-S12-N420	8:1	V1,V2: G1/2" C1,C2: 1/2" SAE 6000 DR,BR,M1,M2: G1/4"	①②:350 ③:40	①②:100-350 ③:10-60	①②:132 ③:6

VALVES FOR MOTORS

MBDN-150-AMSR OVERCENTRE WITH BRAKE RELEASE

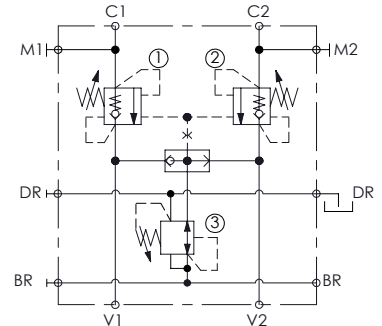
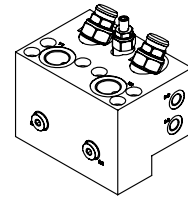

SPECIFICATIONS

Max. operating pressure:	420 bar
Rated flow:	150 l/min
Manifold:	Steel
Weight:	11 kg

SEALING CAP

Ordering code:
ST000012



NOTES

Setting: at least 1.3 times the load induced pressure
Designed for REXROTH A2FE 45-56-63 motors

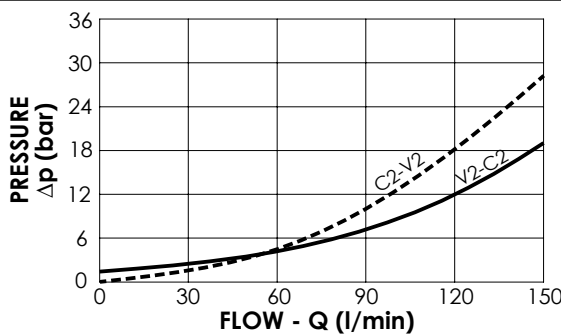
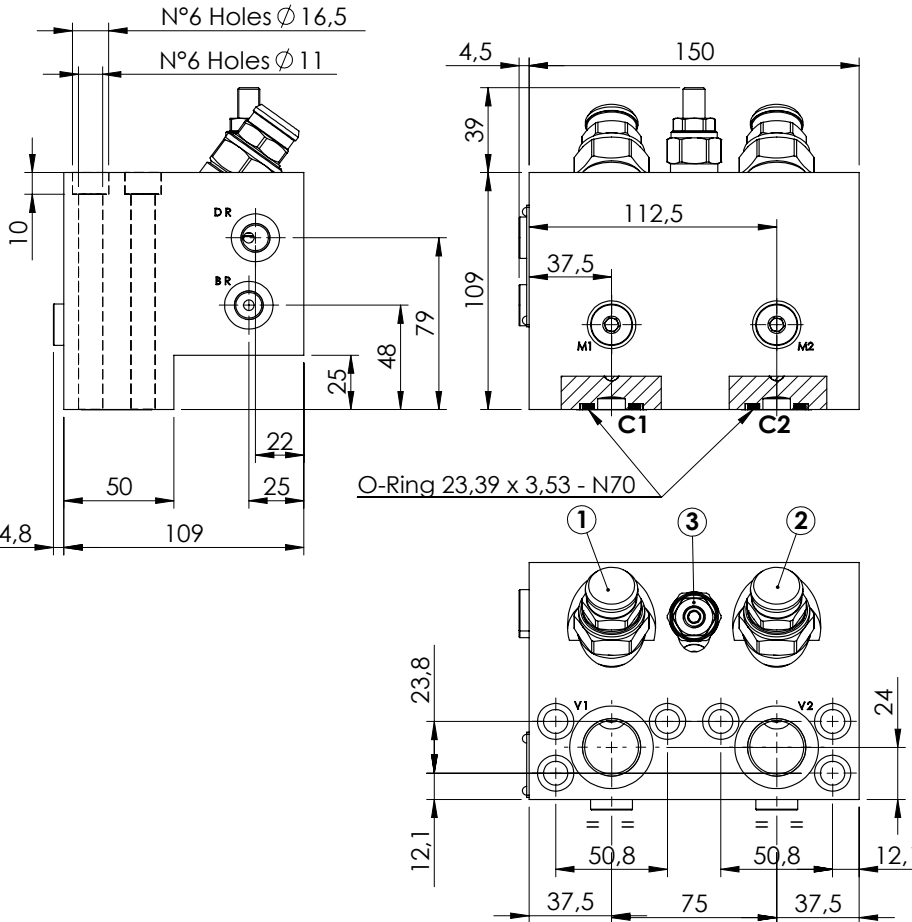

ORDERING CODES

Quick code	Description	Pilot ratio	Main ports size	Standard setting (bar, Q=5 l/min)	Adjust. range (bar)	Pressure increase (bar/turn)
MB000347	MBDN-150-AMSR-04-S34-N420	4:1	V1,V2:G3/4" C1,C2:3/4" SAE 6000 BR,DR,M1,M2:G1/4"	①②: 350 ③: 30	①②:100-350 ③: 10-60	①②: 104 ③: 6
MB000350	MBDN-150-AMSR-08-S34-N420	8:1	V1,V2:G3/4" C1,C2:3/4" SAE 6000 BR,DR,M1,M2:G1/4"	①②: 380 ③: 30	①②:100-420 ③: 10-60	①②: 82 ③: 6

VALVES FOR MOTORS

MBDN-150-AMSR OVERCENTRE WITH BRAKE RELEASE

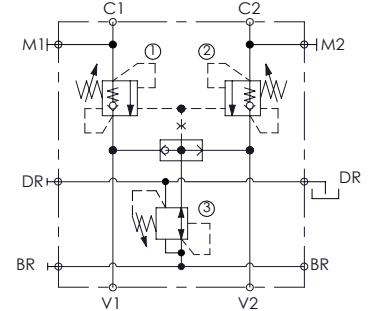
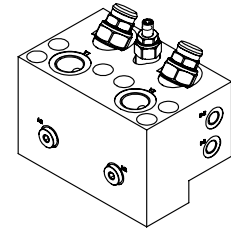
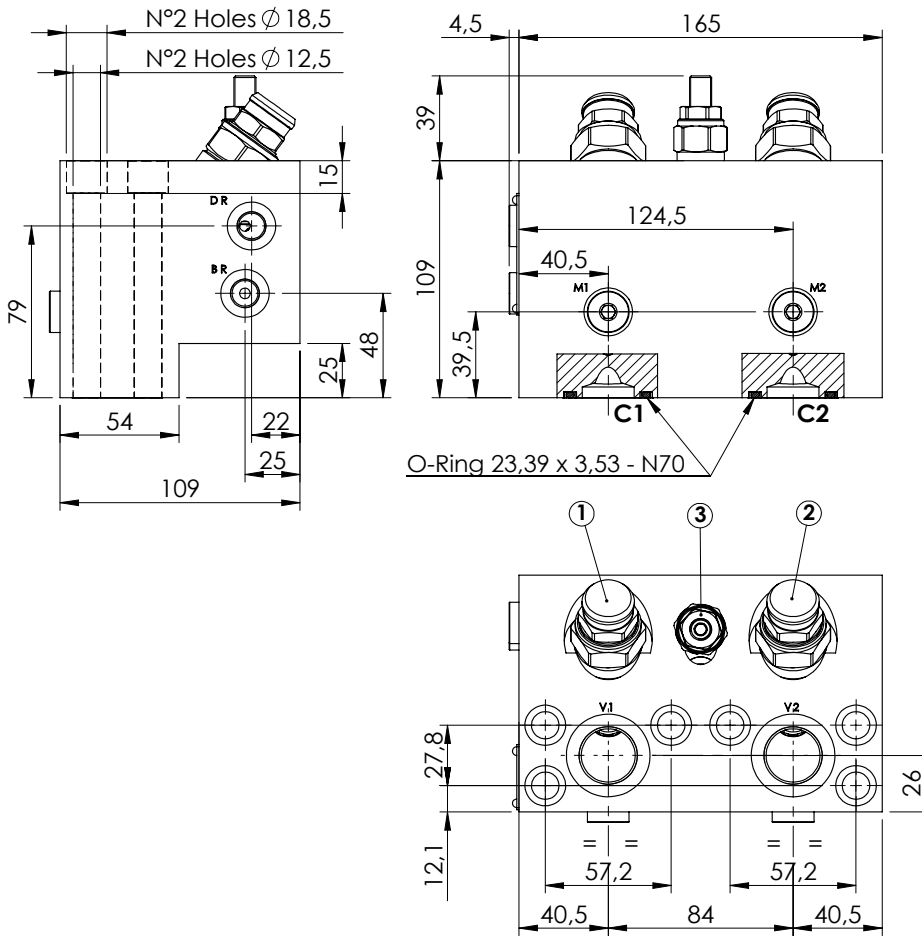

SPECIFICATIONS

Max. operating pressure:	420 bar
Rated flow:	150 l/min
Manifold:	Steel
Weight:	12,07 kg

SEALING CAP

Ordering code:
ST000012



NOTES

Setting: at least 1.3 times the load induced pressure
Designed for REXROTH A2FE 80-90 motors

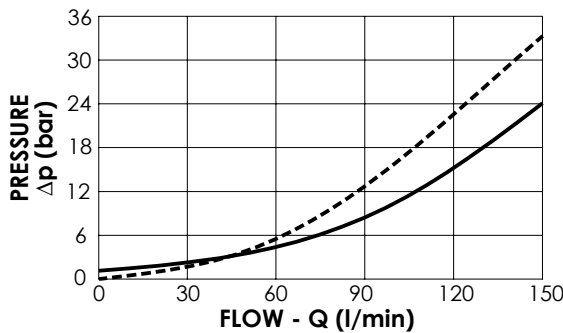

ORDERING CODES

Quick code	Description	Pilot ratio	Main ports size	Standard setting (bar, Q=5 l/min)	Adjust. range (bar)	Pressure increase (bar/turn)
MB000477	MBDN-150-AMSR-04-S10-N420	4:1	V1, V2: G 3/4" C1, C2: 1" SAE 6000 BR, DR: G 1/4"	①②: 350 ③: 40	①②: 100-350 ③: 10-60	①②: 104 ③: 6

VALVES FOR MOTORS

MBDN-300-AMSR

OVERCENTRE WITH BRAKE RELEASE

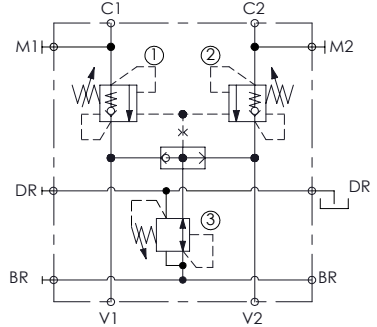
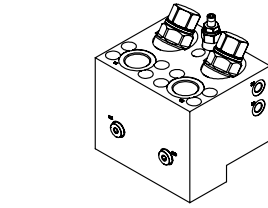
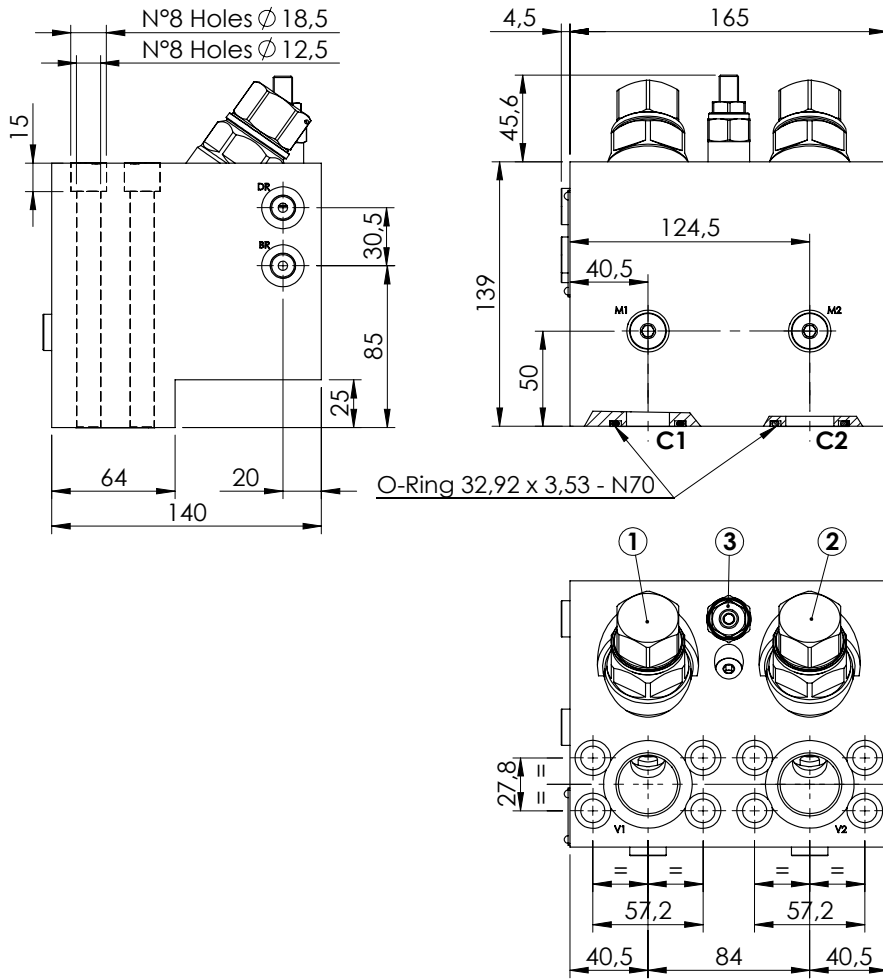

SPECIFICATIONS

Max. operating pressure:	420 bar
Rated flow:	300 l/min
Manifold:	Steel
Weight:	20,44 kg

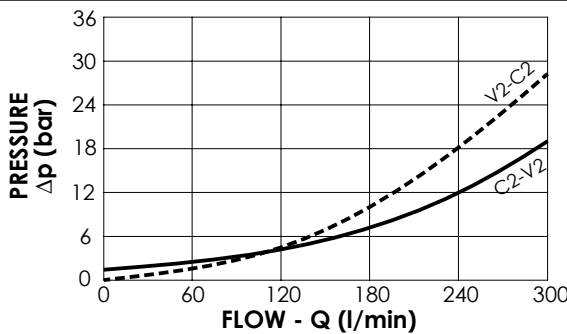

NOTES

Setting: at least 1.3 times the load induced pressure
 Designed for REXROTH A2FE 80-90 motors

ORDERING CODES

Quick code	Description	Pilot ratio	Main ports size	Standard setting (bar, Q=5 l/min)	Adjust. range (bar)	Pressure increase (bar/turn)
MB000402	MBDN-300-AMSR-04-S10-N420	4:1	V1,V2: G 1" C1,C2: 1" SAE 6000 BR,DR,M1,M2: G1/4"	①② : 350 ③ : 30	①② : 100-350 ③ : 10-60	①② : 75 ③ : 6
MB000349	MBDN-300-AMSR-06-S10-N420	6:1	V1,V2: G 1" C1,C2: 1" SAE 6000 BR,DR,M1,M2: G1/4"	①② : 380 ③ : 30	①② : 100-420 ③ : 10-60	①② : 62 ③ : 6

VALVES FOR MOTORS

MBDN-320-AMSR OVERCENTRE WITH BRAKE RELEASE

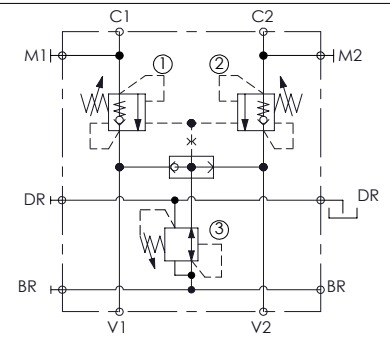
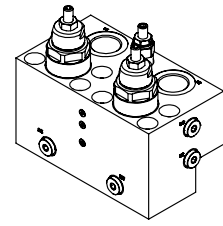
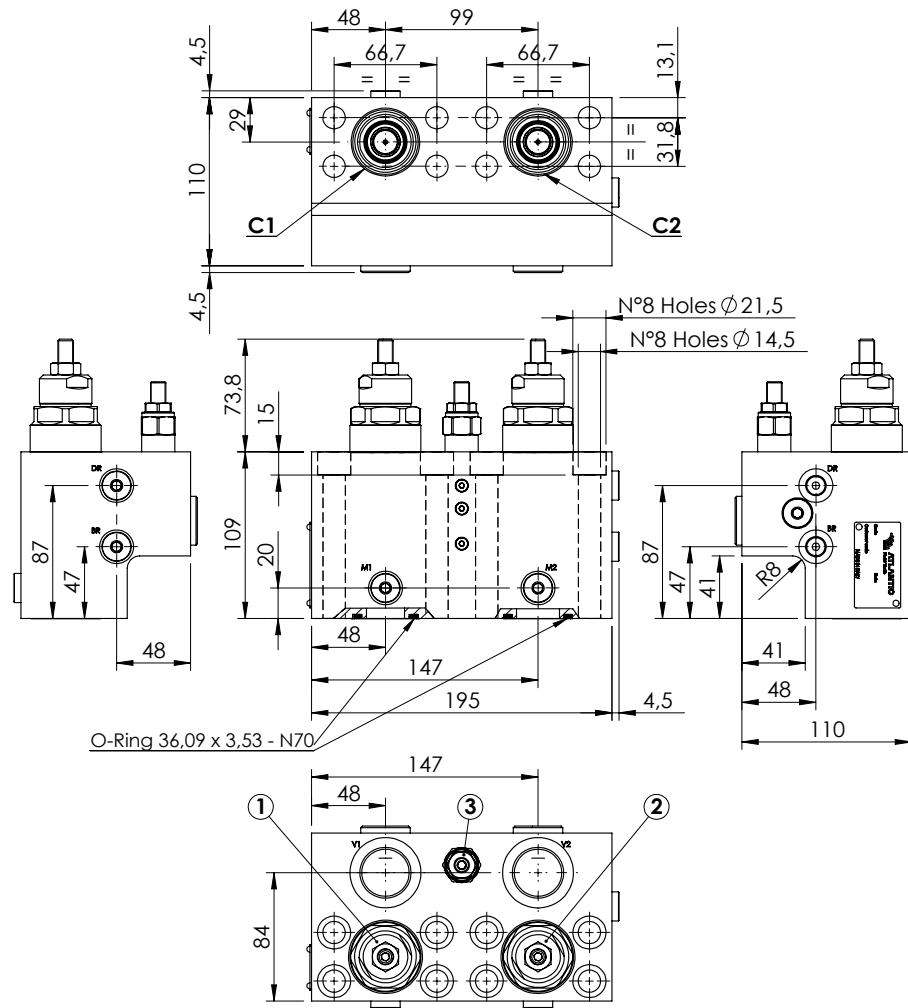

SPECIFICATIONS

Max. operating pressure:	350 bar
Rated flow:	320 l/min
Manifold:	Steel
Weight:	13,7 kg

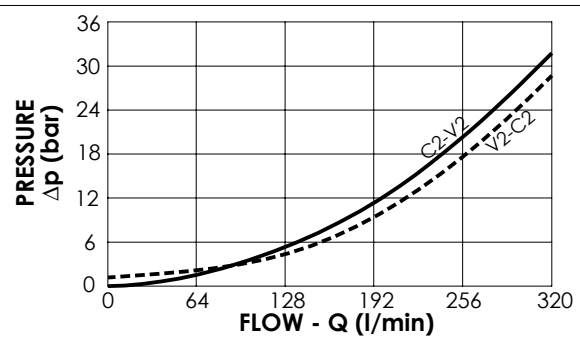

NOTES

Setting: at least 1.3 times the load induced pressure
 Designed for REXROTH A2FE 107-125 160-180 motors

ORDERING CODES

Quick code	Description	Pilot ratio	Main ports size	Standard setting (bar, Q=5 l/min)	Adjust. range (bar)	Pressure increase (bar/turn)
MB000563	MBDN-320-AMSR-08-S11-N350	8:1	V1,V2: G 1" C1,C2: 1-1/4" SAE 6000 BR,DR,M1,M2: G1/4"	① ②: 350 ③: 40	① ②: 140-350 ③: 10-60	① ②: 56 ③: 6,5

VALVES FOR WINCHES

MBSN-100-ZMSF

**PILOT ASSISTED
OVERCENTRE**

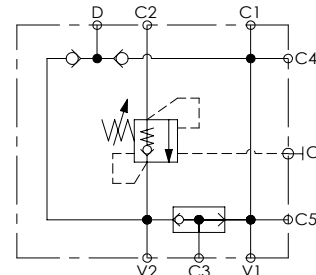
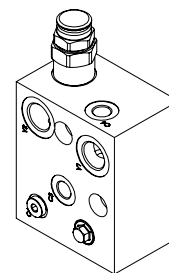
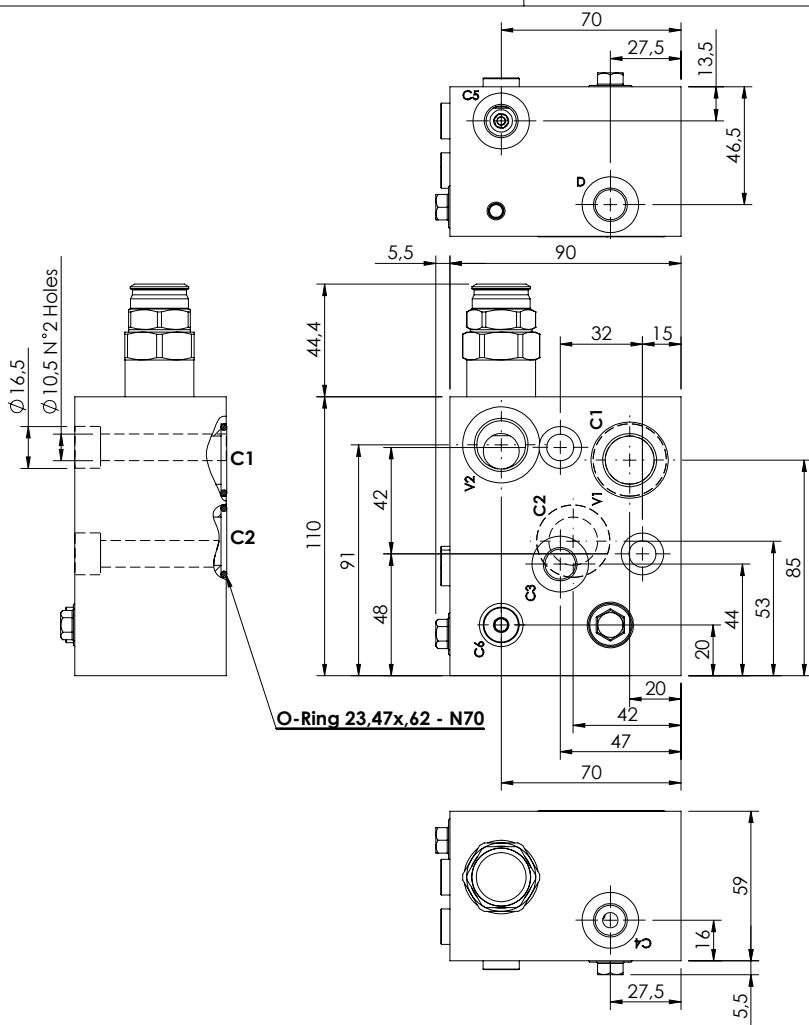

SPECIFICATIONS

Max. operating pressure:	350 bar
Rated flow:	100 l/min
Manifold:	Aluminum
Weight:	1,61 kg

SEALING CAP

Ordering code:
PT000243

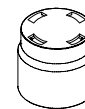

NOTES

Setting: at least 1.3 times the load induced pressure

Designed for DANFOSS motors OMS series.

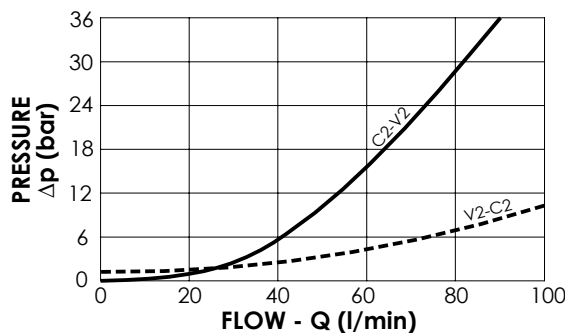

ORDERING CODES

Quick code	Description	Pilot ratio	Main ports size	Standard setting (bar, Q=5 l/min)	Adjust. range (bar)	Pressure increase (bar/turn)
MB000925	MBSN-100-ZMSF-04-G12-N350	4:1	V1, V2: G1/2" C6: G1/8" C1, C2: $\phi 19$ D, C3, C4, C5: G1/4"	250	100-350	124

VALVES FOR WINCHES

MBSN-250-AMSF

**SINGLE ACTING
WITH BRAKE RELEASE**

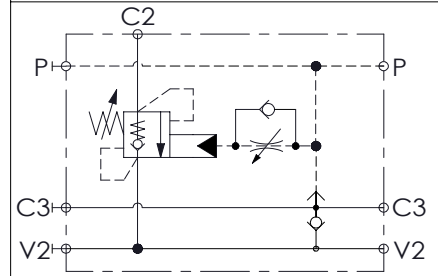
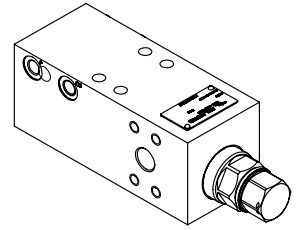
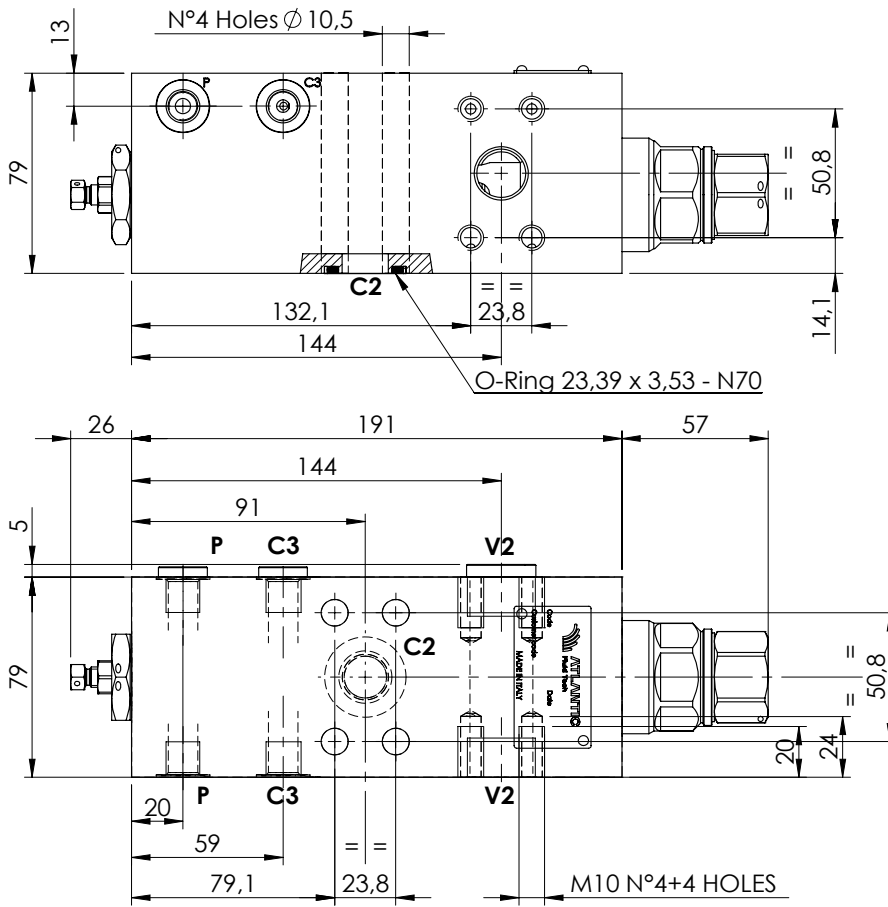

SPECIFICATIONS

Max. operating pressure:	500 bar
Rated flow:	250 l/min
Manifold:	Steel
Weight:	8,1 kg

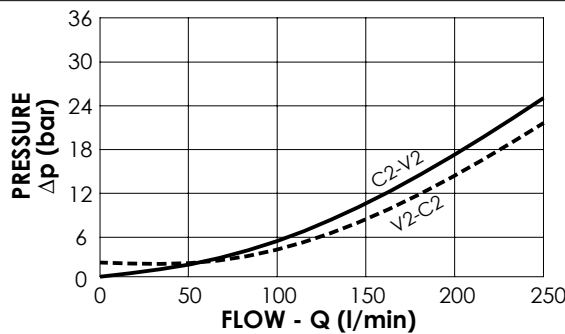

NOTES

Setting: at least 1.3 times the load induced pressure

ORDERING CODES

Quick code	Description	Pilot ratio	Main ports size	Standard setting (bar, Q=5 l/min)	Adjust. range (bar)	Pressure increase (bar/turn)
MB000663	MBSN-250-AMSF-13-S34-N500	13:1	C2,V2 : 3/4" SAE 6000 P,C3 : G 1/4"	500	250-500	104

VALVES FOR WINCHES

MBSN-300-AMSF

**SINGLE ACTING
WITH BRAKE RELEASE**

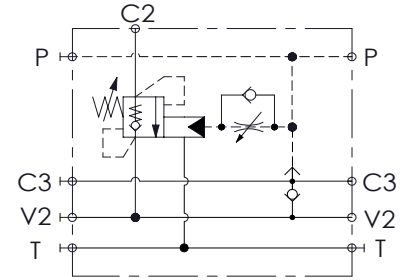
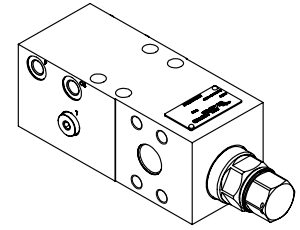
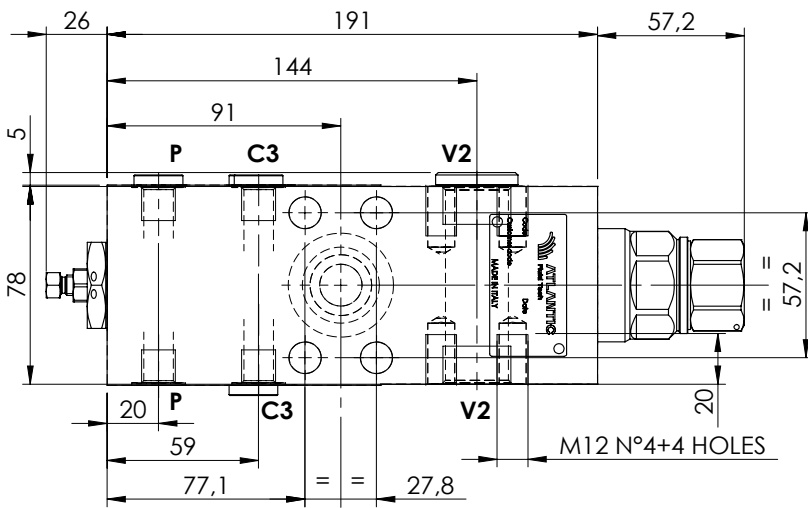
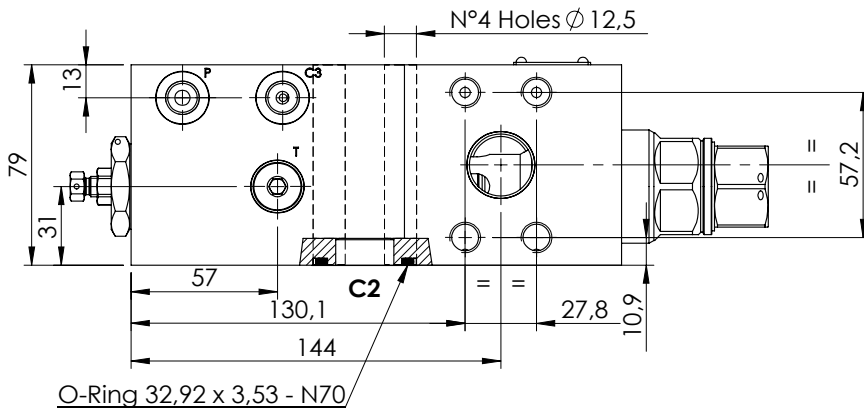

SPECIFICATIONS

Max. operating pressure:	500 bar
Rated flow:	300 l/min
Manifold:	Steel
Weight:	8 kg

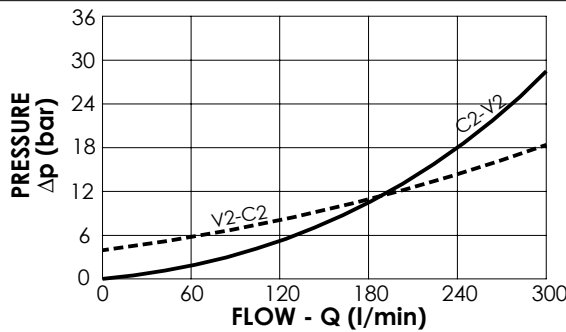

NOTES

Setting: at least 1.3 times the load induced pressure

ORDERING CODES

Quick code	Description	Pilot ratio	Main ports size	Standard setting (bar, Q=5 l/min)	Adjust. range (bar)	Pressure increase (bar/turn)
MB000664	MBSN-300-AMSF-13-S10-N500	13:1	C2,V2 : 1" SAE 6000 P,C3 : G 1/4"	500	250-500	104

VALVES FOR WINCHES

MBSN-300-AMSF

**SINGLE ACTING
WITH BRAKE RELEASE**

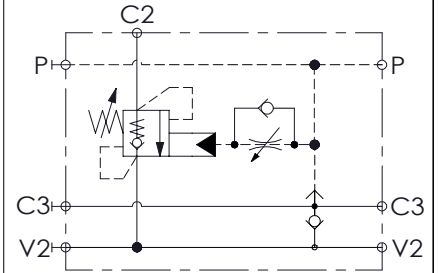
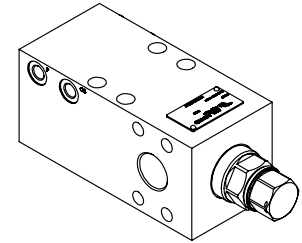
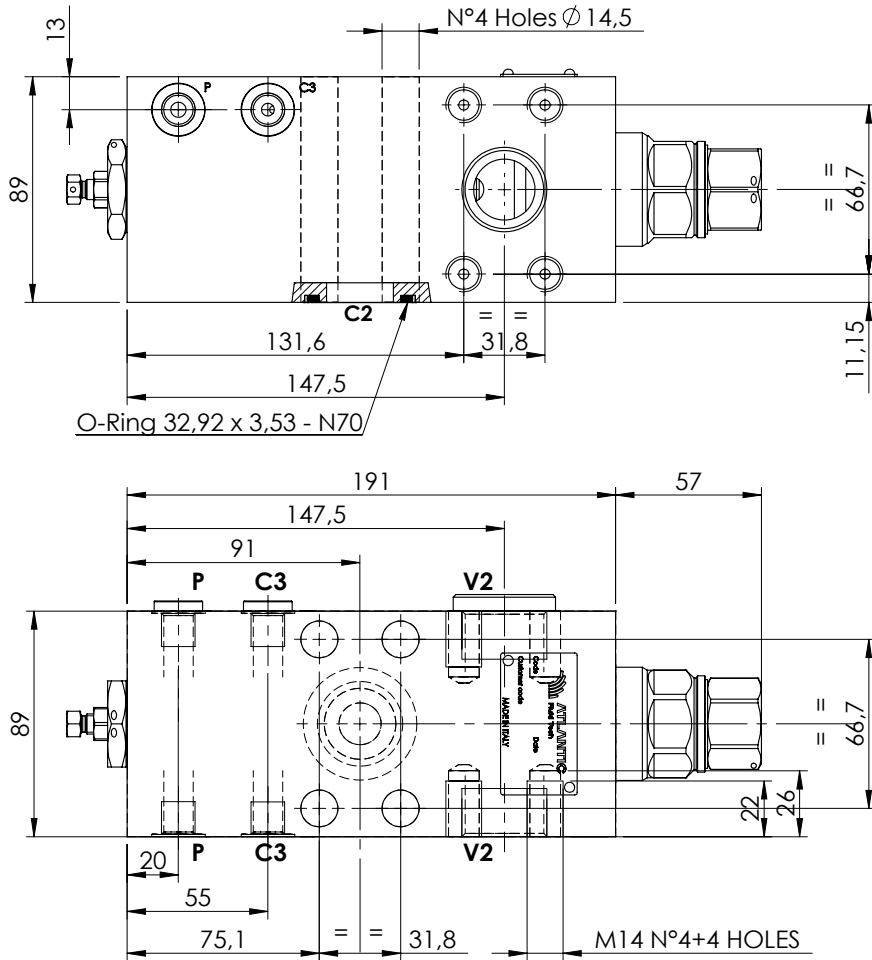

SPECIFICATIONS

Max. operating pressure:	500 bar
Rated flow:	300 l/min
Manifold:	Steel
Weight:	10,9 kg

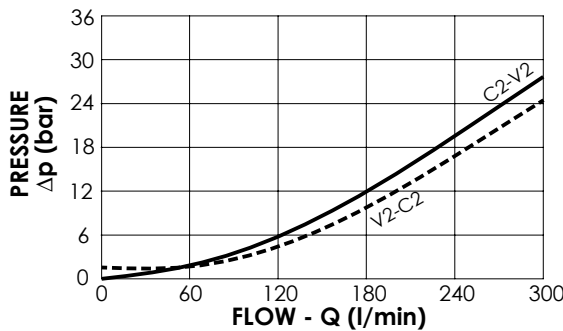

NOTES

Setting: at least 1.3 times the load induced pressure

ORDERING CODES

Quick code	Description	Pilot ratio	Main ports size	Standard setting (bar, Q=5 l/min)	Adjust. range (bar)	Pressure increase (bar/turn)
MB000665	MBSN-300-AMSF-13-S11-N500	13:1	C2,V2 : 1-1/4" SAE 6000 P1,C3 : G 1/4"	500	250-500	104

VALVES FOR WINCHES

MBDN-500-AMSF

**DOUBLE ACTING
WITH BRAKE RELEASE**

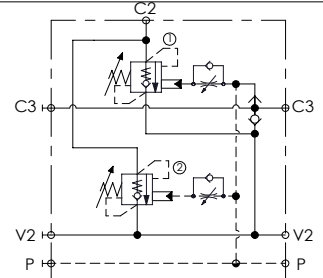
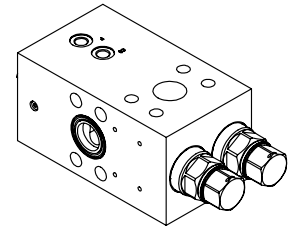
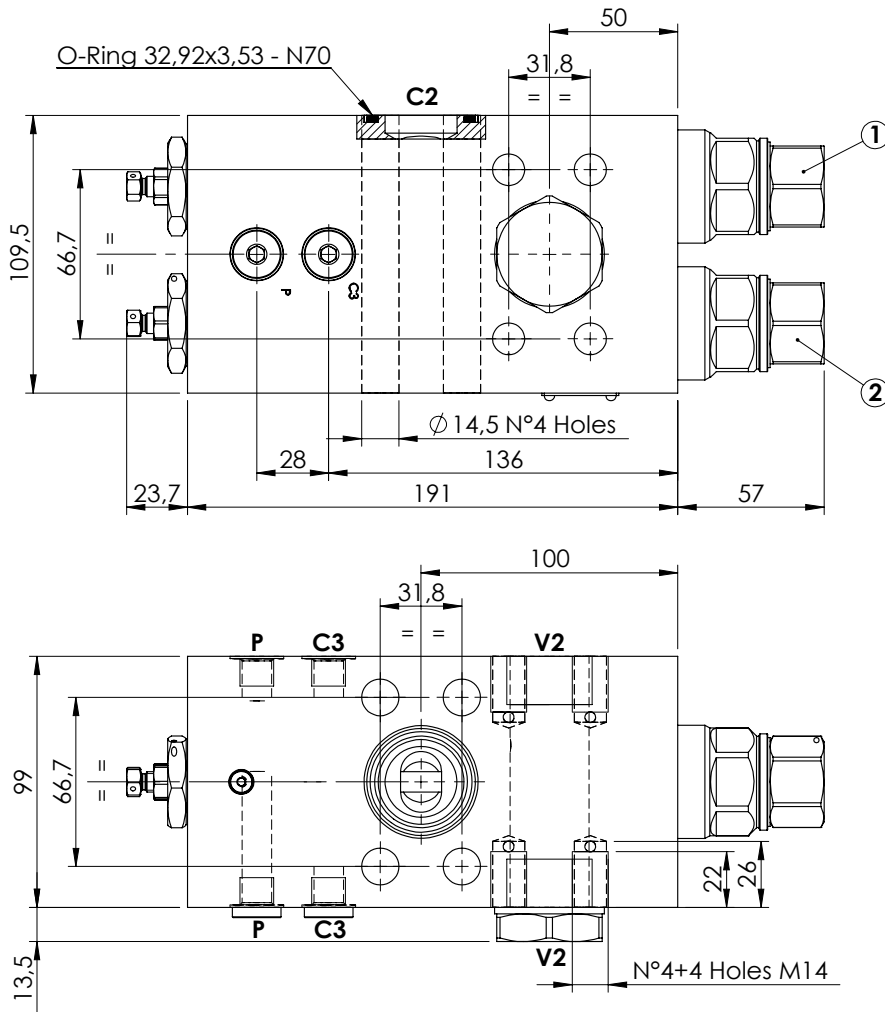

SPECIFICATIONS

Max. operating pressure:	500 bar
Rated flow:	500 l/min
Manifold:	Steel
Weight:	15,15 kg

NOTES

Setting: at least 1.3 times the load induced pressure

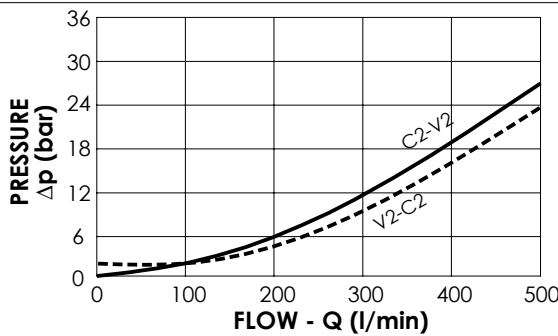

ORDERING CODES

Quick code	Description	Pilot ratio	Main ports size	Standard setting (bar, Q=5 l/min)	Adjust. range (bar)	Pressure increase (bar/turn)
MB000676	MBDN-500-AMSF-13-S11-N500	13:1	C2,V2: 1-1/4" SAE 6000 P,E,C3: G 1/4"	500	250-500	104



1800-OILSOL
1800-645765

<https://oilsolutions.com.au/>

sales@oilsolutions.com.au



ATLANTIC
Fluid Tech

SECTION 9

Motion
Control
Valves



1800-OILSOL
1800-645765

<https://oilsolutions.com.au/>

sales@oilsolutions.com.au

SECTION 9

MOTION CONTROL VALVES



Hydraulic scheme	Valve description	Valve type	Rated flow (l/min)	Max. pressure (bar)	Installation	Main port size	Page
	MNDN-040-LLST	Stabilized	40	350	In line	G 3/8"	9.01.010
	MNDN-120-LLST	Stabilized	120	350	In line	G 3/4"	9.01.020
	MNDN-200-LLST	Stabilized	200	350	In line	G 1"	9.01.030
	MNDN-040-LLSV	Stabilized, with brake release	40	350	In line	G 3/8"	9.02.040
	MNDN-120-LLSV	Stabilized, with brake release	120	350	In line	G 3/4"	9.02.050
	MNDN-200-LLSV	Stabilized, with brake release	200	350	In line	G 1"	9.02.060
	MNDN-040-LLPT	Stabilized and brake, dual setting	40	350	In line	G 3/8"	9.03.070
	MNDN-120-LLPT	Stabilized and brake, dual setting	120	350	In line	G 3/4"	9.03.080
	MNDN-200-LLPT	Stabilized and brake, dual setting	200	350	In line	G1"	9.03.090
	MNDN-040-LLPV	Stabilized and brake, dual setting, with brake release	40	350	In line	G 3/8"	9.03.100
	MNDN-120-LLPV	Stabilized and brake, dual setting, with brake release	120	350	In line	G 3/4"	9.03.110
	MNDN-200-LLPV	Stabilized and brake, dual setting, with brake release	200	350	In line	G 1"	9.03.120

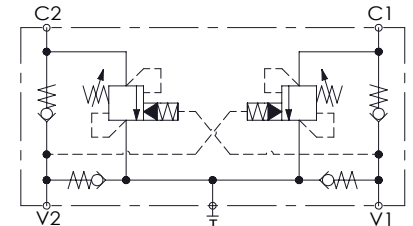
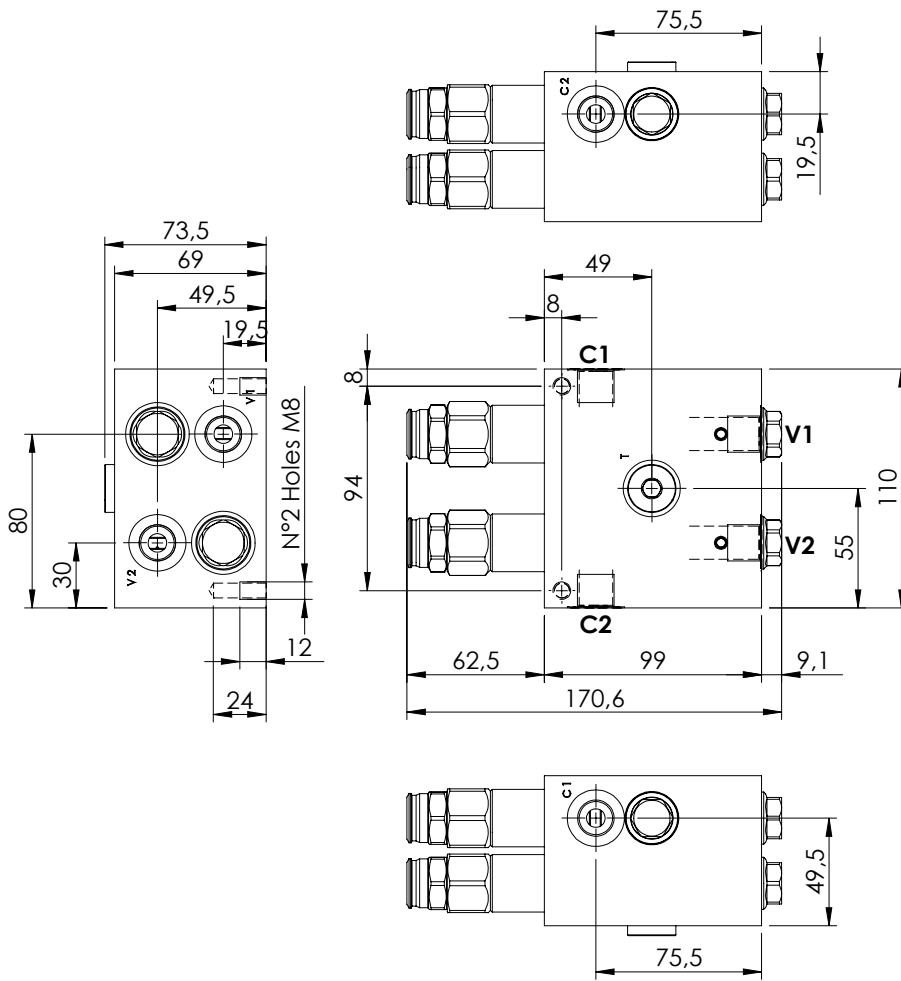
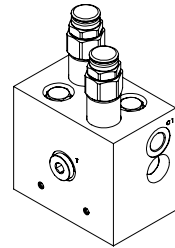

SPECIFICATIONS

Max. operating pressure:	300 bar
Rated flow:	40 l/min
Manifold:	Aluminium
Weight:	2,65 kg

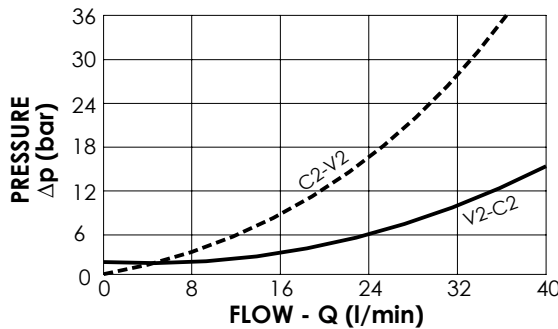

NOTES

Setting: at least 1.3 times the load induced pressure

ORDERING CODES

Quick code	Description	Pilot ratio	Main ports size	Standard setting (bar, Q=5 l/min)	Adjust. range (bar)	Pressure increase (bar/turn)
MN000023	MNDN-040-LLST-09-G38-N300	9:1	V1,V2,C1,C2: G 3/8" T: G 3/8"	150	100-300	119
MN000029	MNDN-040-LLST-03-G38-N300	3:1	V1,V2,C1,C2: G 3/8" T: G 3/8"	150	100-300	119

MNDN-120-LLST

STABILIZED

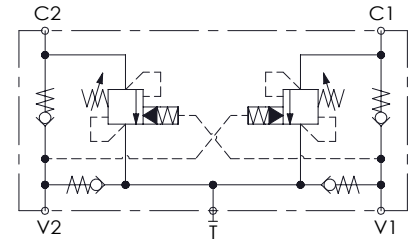
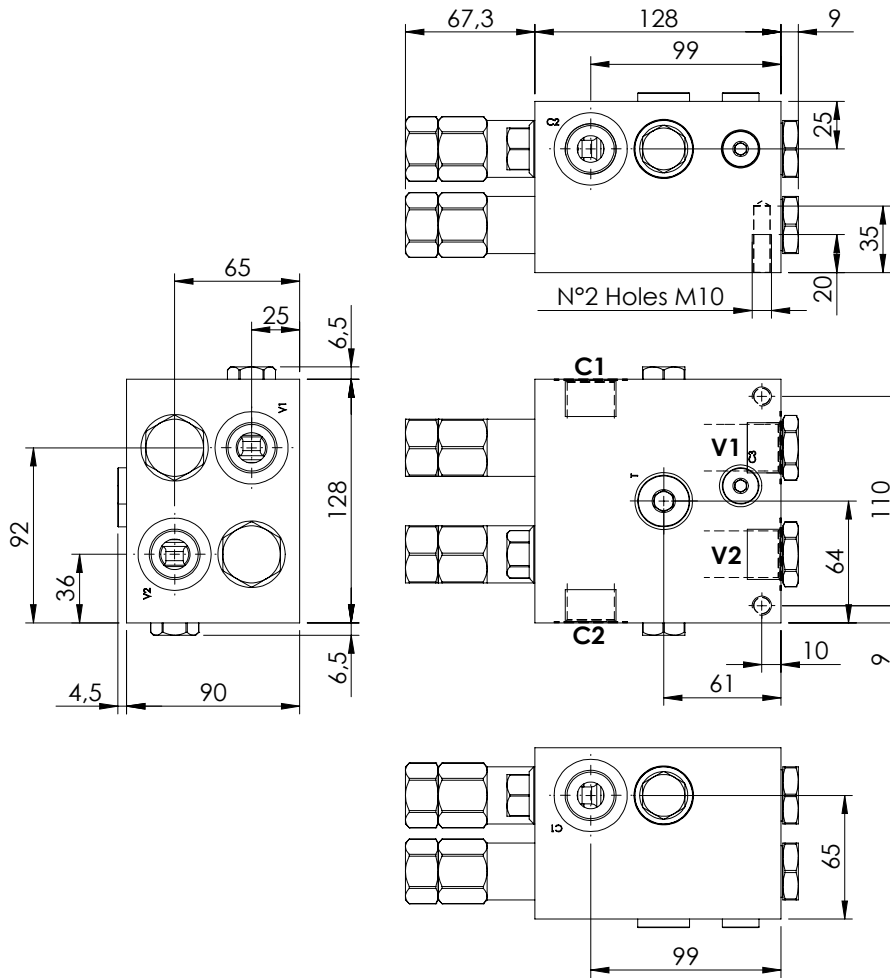
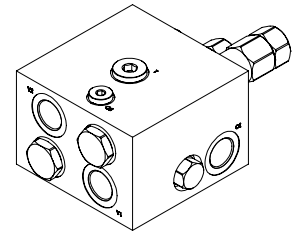

SPECIFICATIONS

Max. operating pressure:	300 bar
Rated flow:	120 l/min
Manifold:	Aluminium
Weight:	5,06 kg

NOTES

Setting: at least 1.3 times the load induced pressure

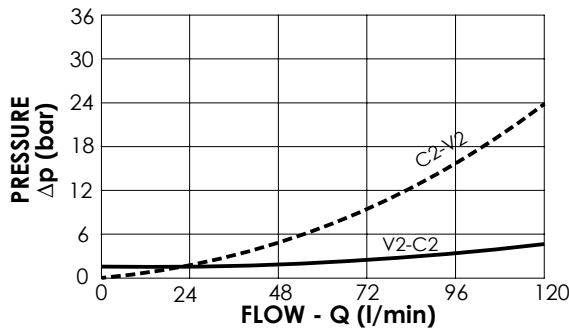

ORDERING CODES

Quick code	Description	Pilot ratio	Main ports size	Standard setting (bar, Q=5 l/min)	Adjust. range (bar)	Pressure increase (bar/turn)
MN000013	MNDN-120-LLST-08-G34-N300	8:1	V1,V2,C1,C2 : G3/4" T : G 1/2"	150	100-300	111
MN000012	MNDN-120-LLST-03-G34-N300	3:1	V1,V2,C1,C2 : G3/4" T : G 1/2"	150	70-210	73

MOTION CONTROL

MNDN-200-LLST

STABILIZED

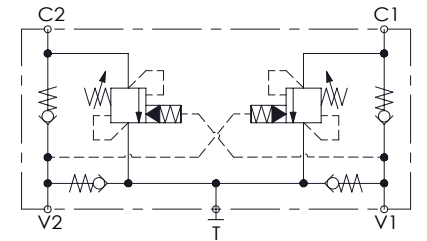
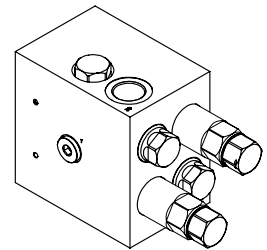
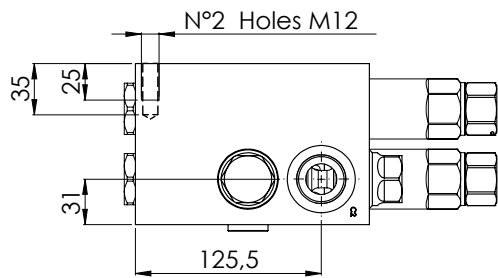
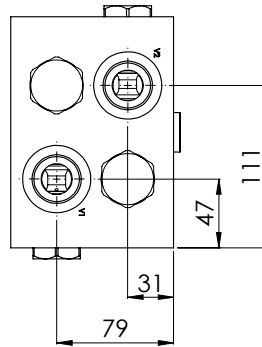
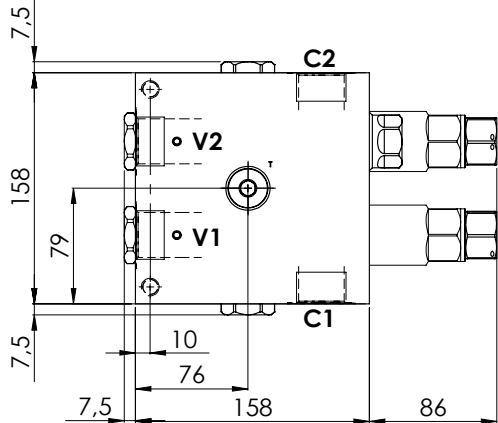
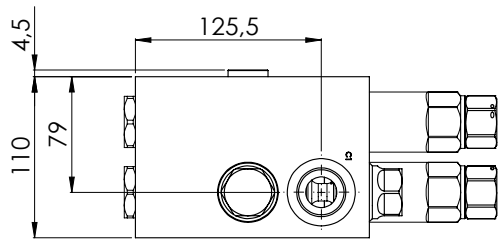

SPECIFICATIONS

Max. operating pressure:	300 bar
Rated flow:	200 l/min
Manifold:	Aluminium
Weight:	9,51 kg

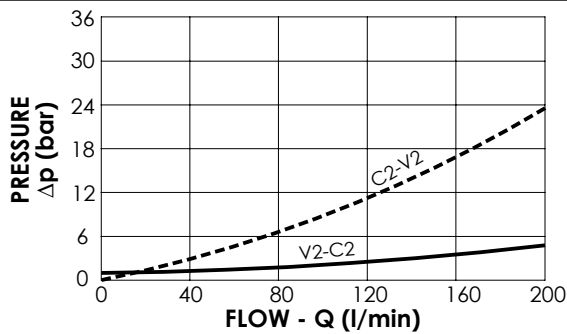

NOTES

Setting: at least 1.3 times the load induced pressure

ORDERING CODES

Quick code	Description	Pilot ratio	Main ports size	Standard setting (bar, Q=5 l/min)	Adjust. range (bar)	Pressure increase (bar/turn)
MN000020	MNDN-200-LLST-08-G10-N300	8:1	V1,V2,C1,C2: G1" T: G1/2"	150	120-300	65

MNDN-040-LLSV

STABILIZED WITH BRAKE RELEASE

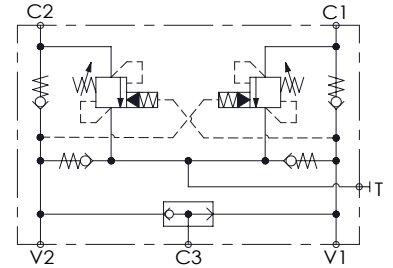
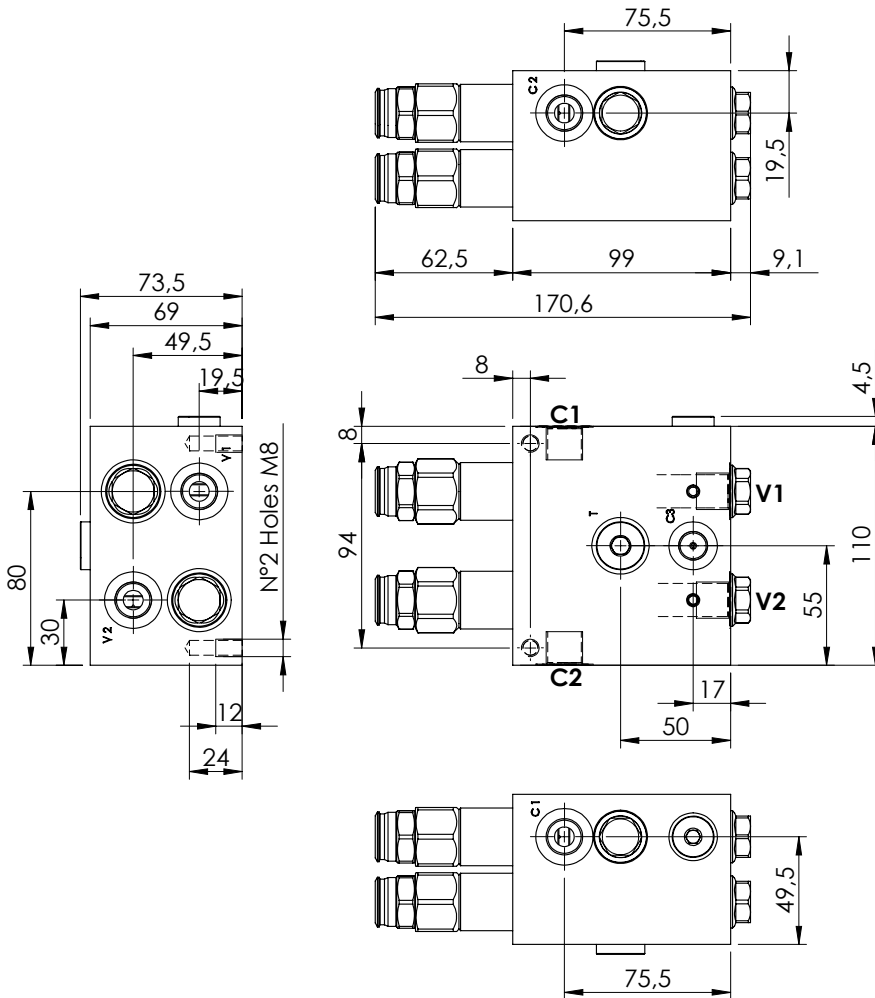
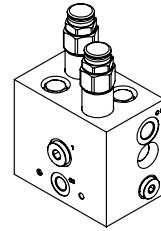

SPECIFICATIONS

Max. operating pressure:	300 bar
Rated flow:	40 l/min
Manifold:	Aluminium
Weight:	2,66 kg

NOTES

Setting: at least 1.3 times the load induced pressure

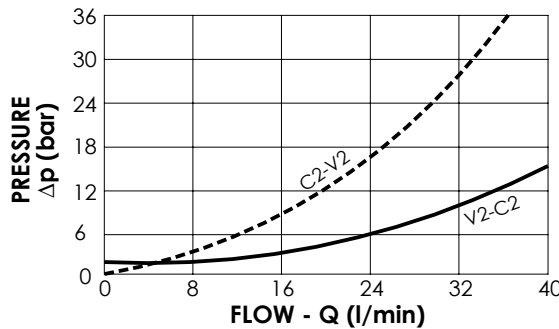

ORDERING CODES

Quick code	Description	Pilot ratio	Main ports size	Standard setting (bar, Q=5 l/min)	Adjust. range (bar)	Pressure increase (bar/turn)
MN000008	MNDN-040-LLSV-09-G38-N300	9:1	V1,V2,C1,C2,T: G 3/8" C3: G 1/4"	150	100-300	119
MN000032	MNDN-040-LLSV-09-G38-N200	9:1	V1,V2,C1,C2,T: G 3/8" C3: G 1/4"	150	70-150	63
MN000033	MNDN-040-LLSV-03-G38-N300	3:1	V1,V2,C1,C2,T: G 3/8" C3: G 1/4"	150	100-300	119
MN000034	MNDN-040-LLSV-03-G38-N200	3:1	V1,V2,C1,C2,T: G 3/8" C3: G 1/4"	150	70-150	63

MOTION CONTROL

MNDN-120-LLSV

STABILIZED WITH BRAKE RELEASE

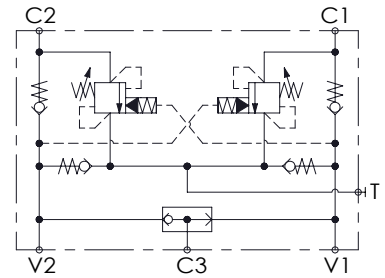
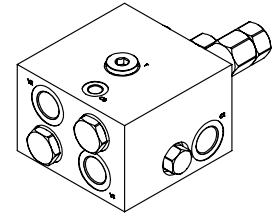
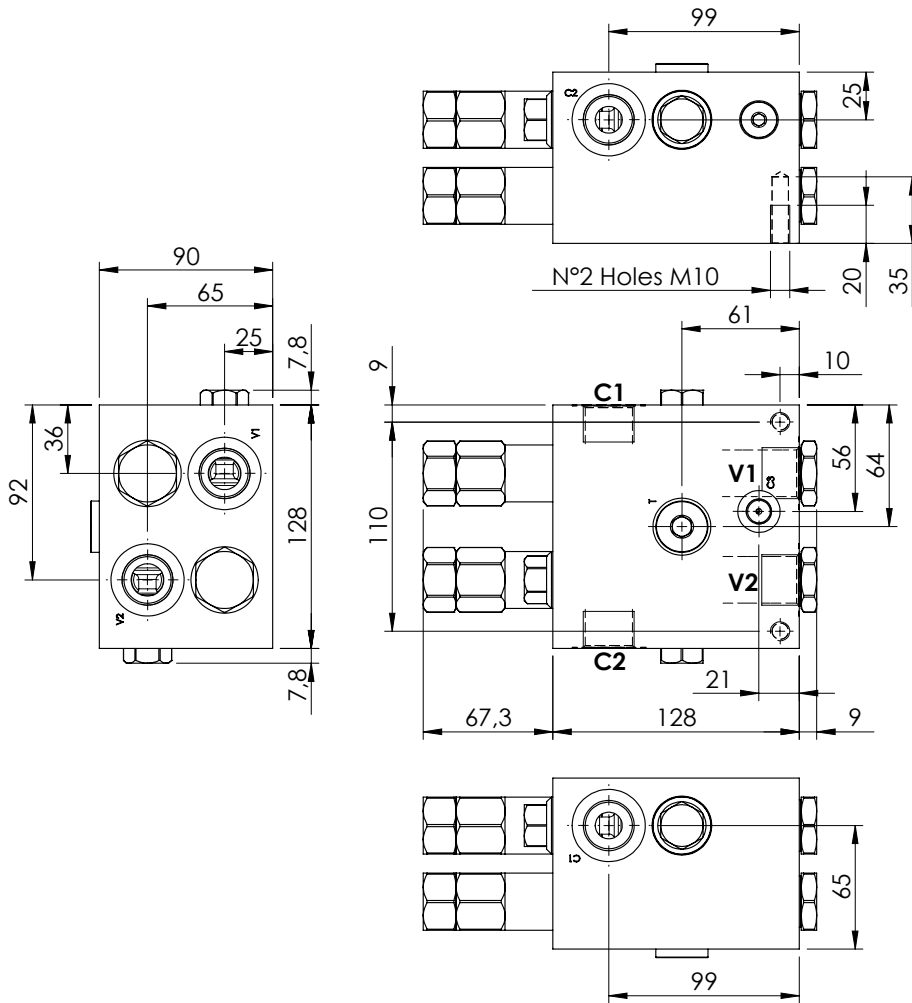

SPECIFICATIONS

Max. operating pressure:	300 bar
Rated flow:	120 l/min
Manifold:	Aluminium
Weight:	5,03 kg

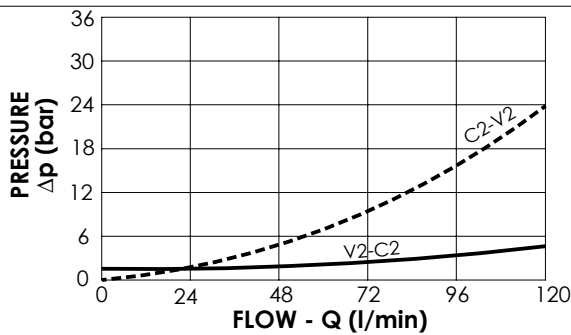

NOTES

Setting: at least 1.3 times the load induced pressure

ORDERING CODES

Quick code	Description	Pilot ratio	Main ports size	Standard setting (bar, Q=5 l/min)	Adjust. range (bar)	Pressure increase (bar/turn)
MN000014	MNDN-120-LLSV-08-G34-N300	8:1	V1,V2,C1,C2: G 3/4" T: G 1/2"; C3: G 1/4"	150	100-300	111
MN000015	MNDN-120-LLSV-03-G34-N300	3:1	V1,V2,C1,C2: G 3/4" T: G 1/2"; C3: G 1/4"	150	100-300	111

MOTION CONTROL

MNDN-200-LLSV

STABILIZED
WITH BRAKE RELEASE

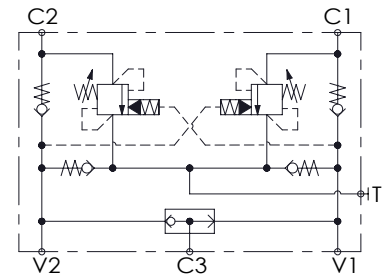
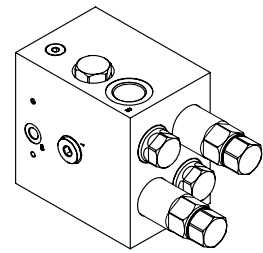
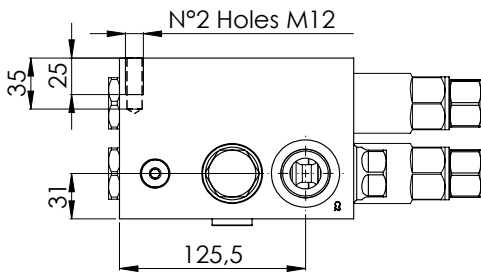
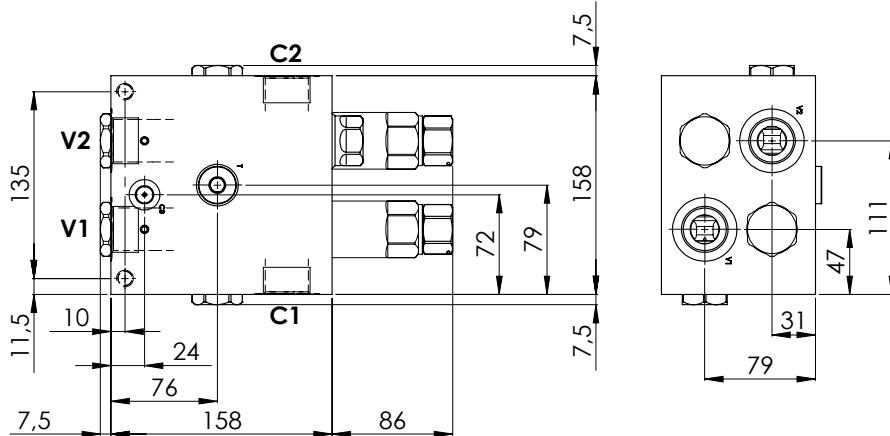
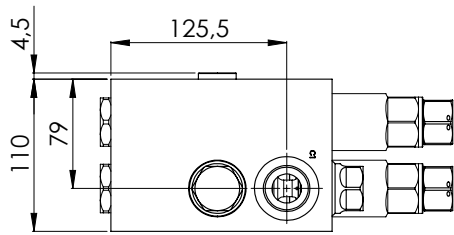

SPECIFICATIONS

Max. operating pressure:	300 bar
Rated flow:	200 l/min
Manifold:	Aluminium
Weight:	9,51 kg

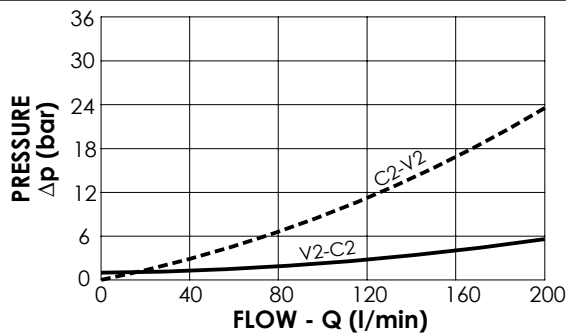

NOTES

Setting: at least 1.3 times the load induced pressure

ORDERING CODES

Quick code	Description	Pilot ratio	Main ports size	Standard setting (bar, Q=5 l/min)	Adjust. range (bar)	Pressure increase (bar/turn)
MN000021	MNDN-200-LLSV-08-G10-N300	8:1	V1,V2,C1,C2: G1" T: G1/2"; C3: G 1/4"	150	120-300	65

MOTION CONTROL

MNDN-040-LLPT

SOFT STOP
DUAL SETTING

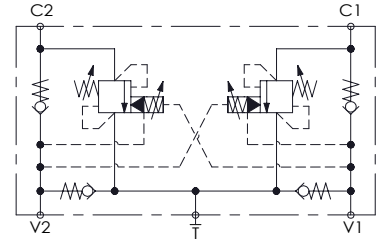
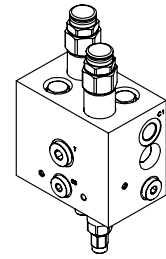
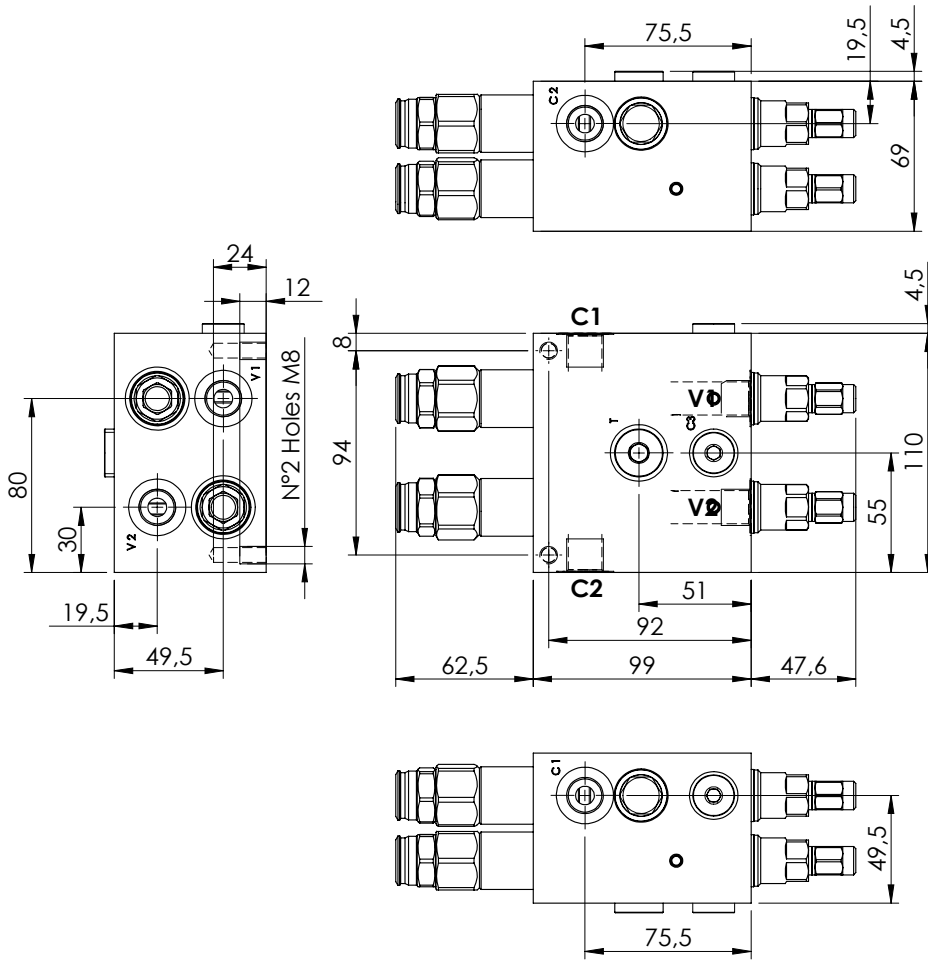

SPECIFICATIONS

Max. operating pressure:	300 bar
Rated flow:	40 l/min
Manifold:	Aluminium
Weight:	2,78 kg

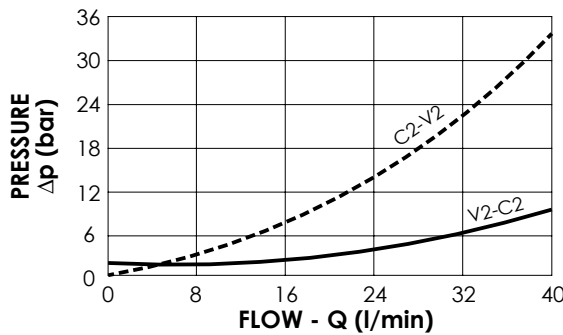

NOTES

Setting: at least 1.3 times the load induced pressure

ORDERING CODES

Quick code	Description	Pilot ratio	Main ports size	Standard setting (bar, Q=5 l/min)	Adjust. range (bar)	Pressure increase (bar/turn)
MN000024	MNDN-040-LLPT-09-G38-N300	9:1	V1,V2,C1,C2: G3/8" T: G3/8"	Start: 300 Brake: 120	100-300	119

MOTION CONTROL

MNDN-120-LLPT

SOFT STOP
DUAL SETTING

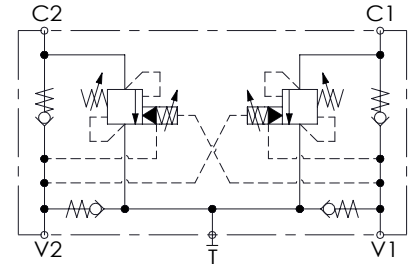
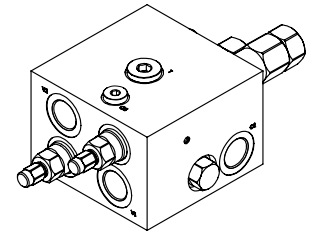
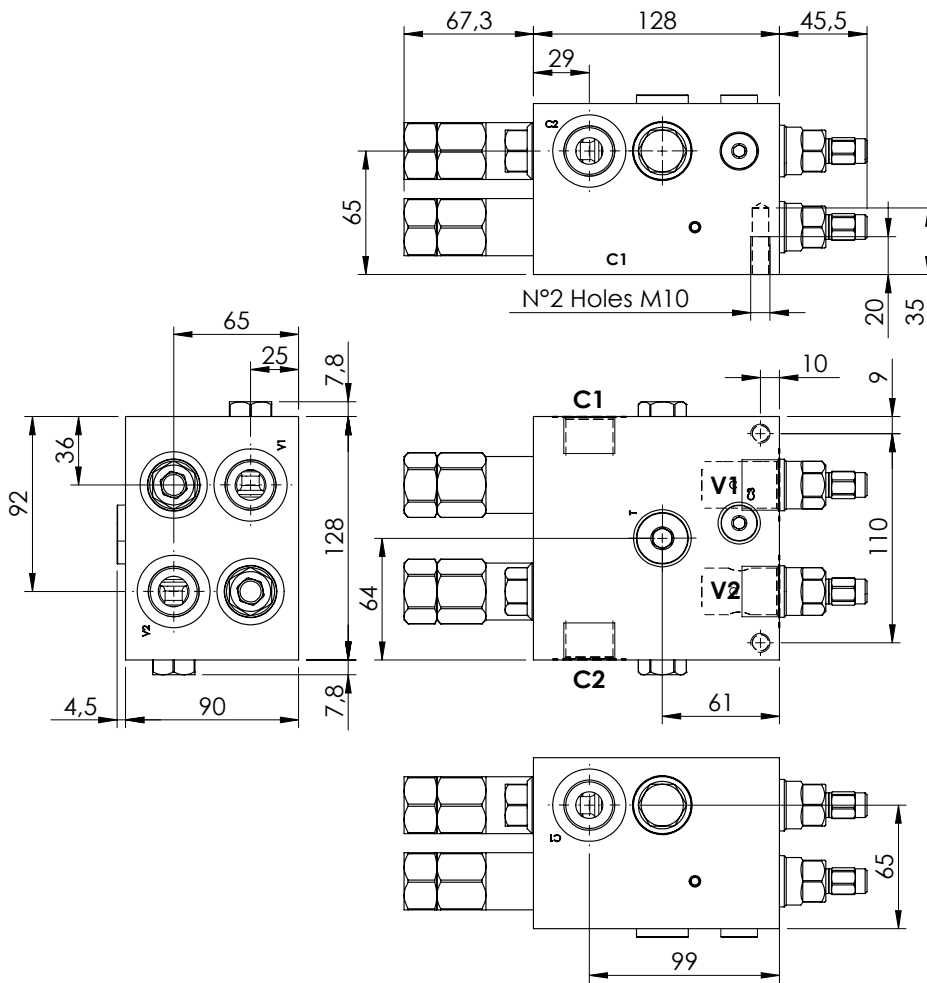

SPECIFICATIONS

Max. operating pressure:	300 bar
Rated flow:	120 l/min
Manifold:	Aluminium
Weight:	5,14 kg

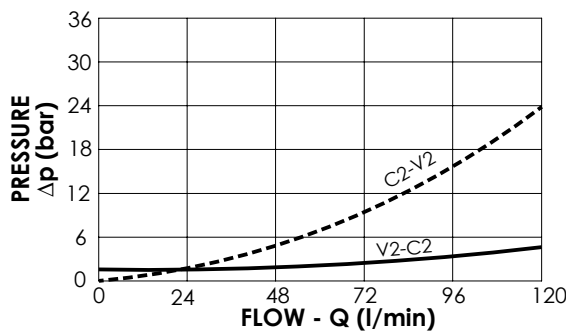

NOTES

Setting: at least 1.3 times the load induced pressure

ORDERING CODES

Quick code	Description	Pilot ratio	Main ports size	Standard setting (bar, Q=5 l/min)	Adjust. range (bar)	Pressure increase (bar/turn)
MN000017	MNDN-120-LLPT-08-G34-N300	8:1	V1,V2,C1,C2 : G3/4" T : G 1/2"	Start: 300 Brake: 120	100-300	111
MN000031	MNDN-120-LLPT-03-G34-N350-T	8:1	V1,V2,C1,C2 : G3/4" T : G 1/2"	Start: 350 Brake: 120	100-350	111
MN000047	MNDN-120-LLPT-03-G34-N300	3:1	V1,V2,C1,C2 : G3/4" T : G 1/2"	Start: 300 Brake: 120	100-300	111
MN000016	MNDN-120-LLPT-03-G34-N200	3:1	V1,V2,C1,C2 : G3/4" T : G 1/2"	Start: 180 Brake: 90	70-210	73

MOTION CONTROL

MNDN-200-LLPT

SOFT STOP
DUAL SETTING

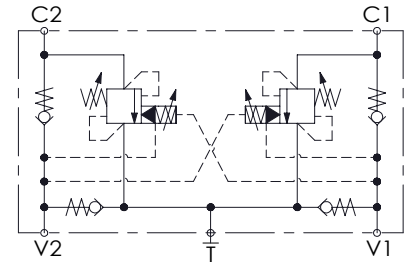
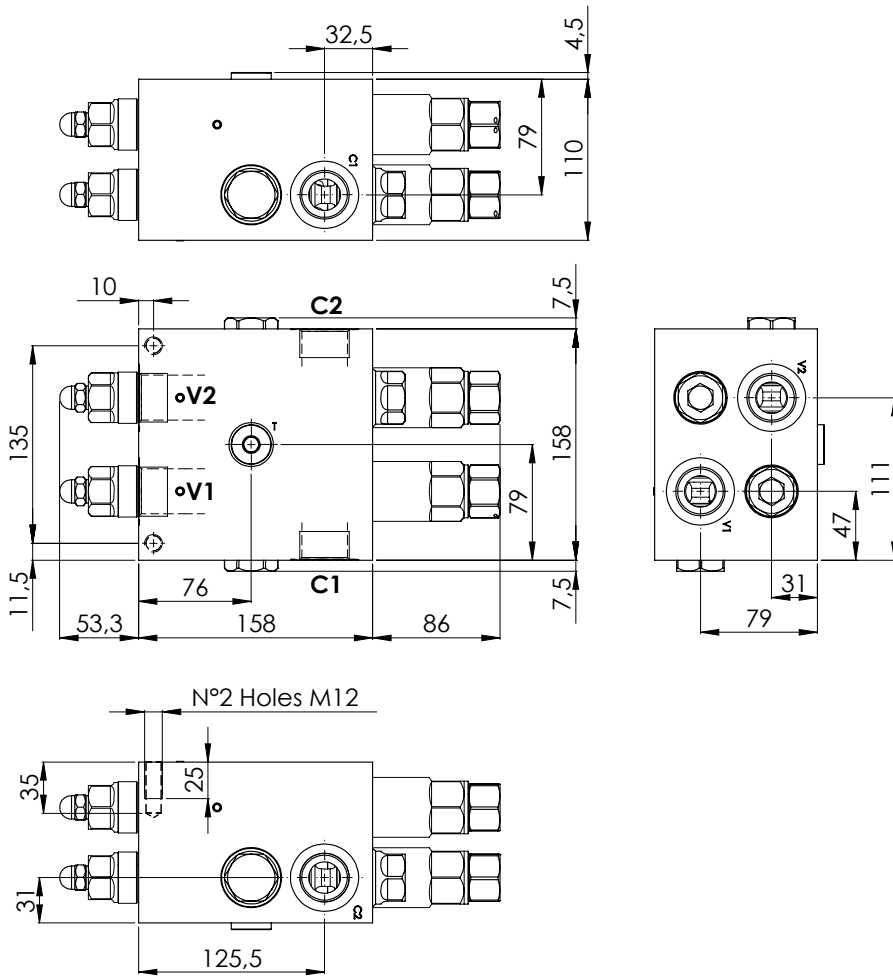
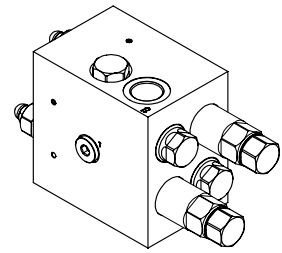

SPECIFICATIONS

Max. operating pressure:	300 bar
Rated flow:	200 l/min
Manifold:	Aluminium
Weight:	9,8 kg

NOTES

Setting: at least 1.3 times the load induced pressure

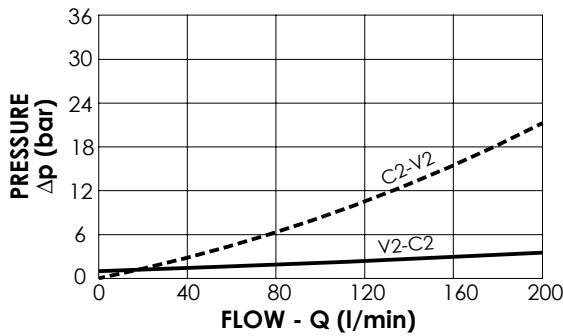

ORDERING CODES

Quick code	Description	Pilot ratio	Main ports size	Standard setting (bar, Q=5 l/min)	Adjust. range (bar)	Pressure increase (bar/turn)
MN000004	MNDN-200-LLPT-08-G10-N300	8:1	V1,V2,C1,C2 : G1" T : G1/2"	Start: 300 Brake: 120	120-300	65

MOTION CONTROL

MNDN-040-LLPV

**SOFT STOP
DUAL SETTING
WITH BRAKE RELEASE**

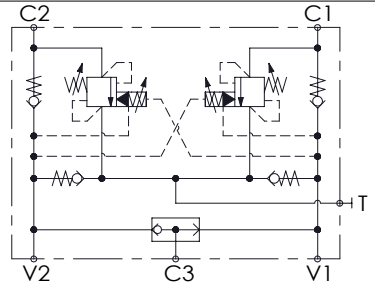
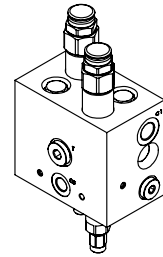
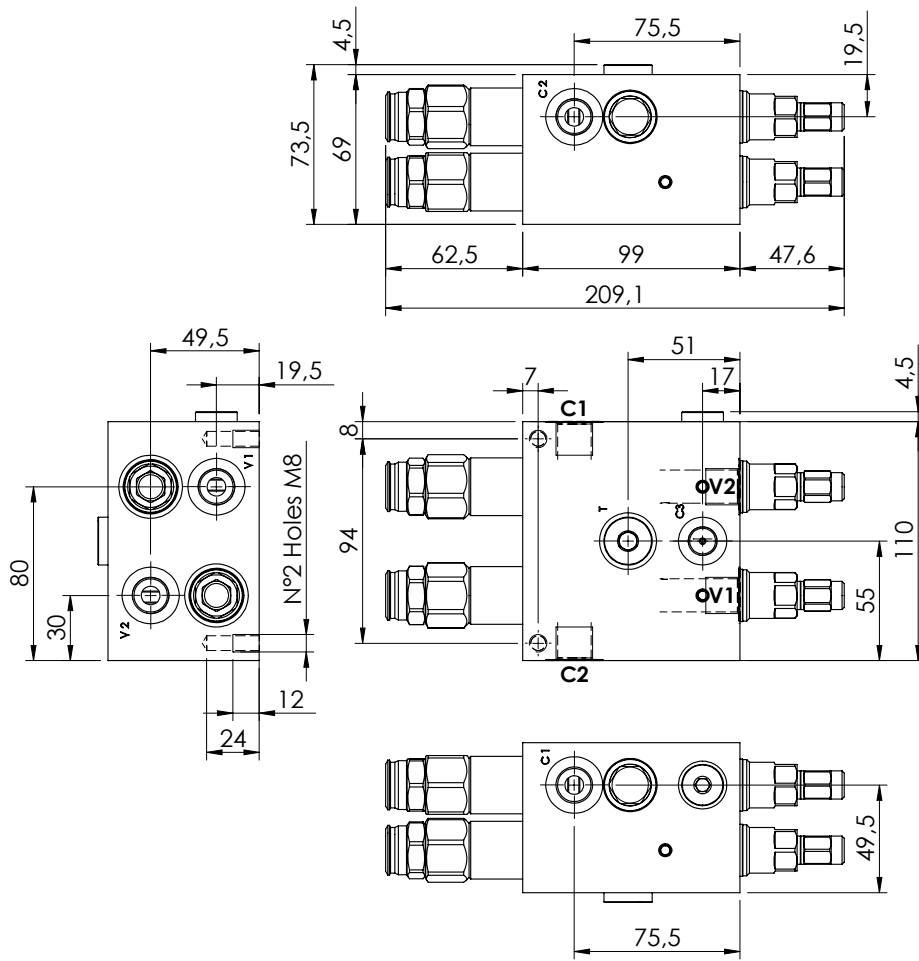

SPECIFICATIONS

Max. operating pressure:	300 bar
Rated flow:	40 l/min
Manifold:	Aluminium
Weight:	2,76 kg

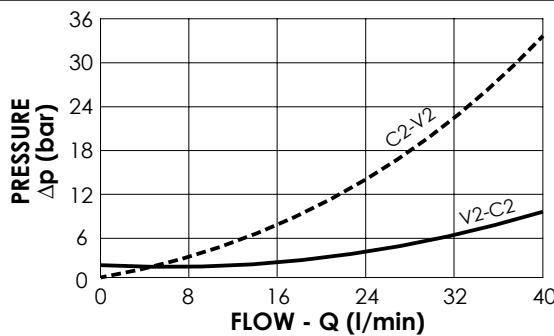

NOTES

Setting: at least 1.3 times the load induced pressure

ORDERING CODES

Quick code	Description	Pilot ratio	Main ports size	Standard setting (bar, Q=5 l/min)	Adjust. range (bar)	Pressure increase (bar/turn)
MN000019	MNDN-040-LLPV-09-G38-N300	9:1	V1,V2,C1,C2,T: G 3/8" C3 : G 1/4"	Start: 300 Brake:120	100-300	119
MN000028	MNDN-040-LLPV-09-G38-N200	9:1	V1,V2,C1,C2,T: G 3/8" C3 : G 1/4"	Start: 200 Brake: 90	60-210	63

MNDN-120-LLPV

**SOFT STOP
DUAL SETTING
WITH BRAKE RELEASE**

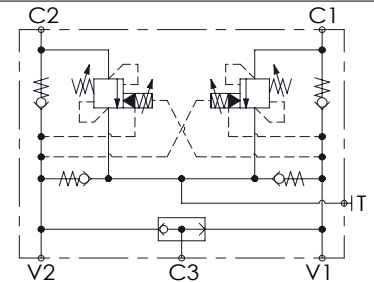
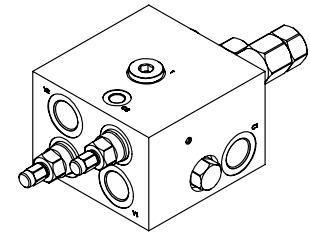
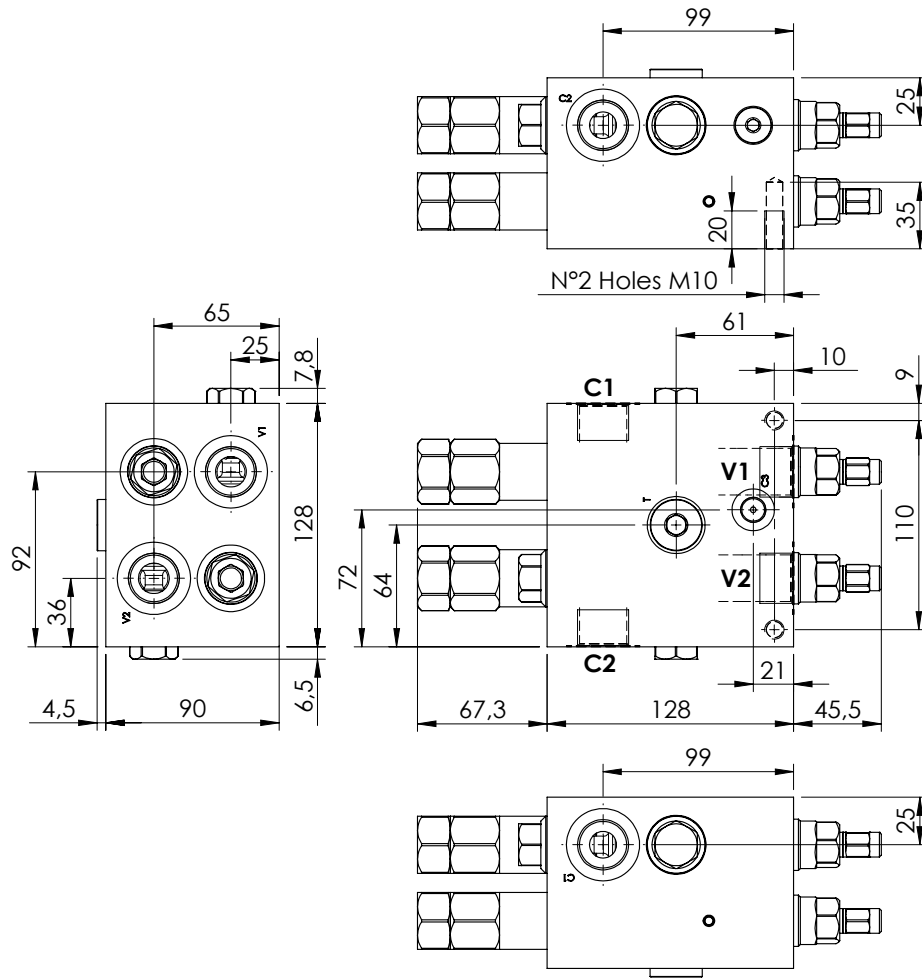

SPECIFICATIONS

Max. operating pressure:	300 bar
Rated flow:	120 l/min
Manifold:	Aluminium
Weight:	5,12 kg

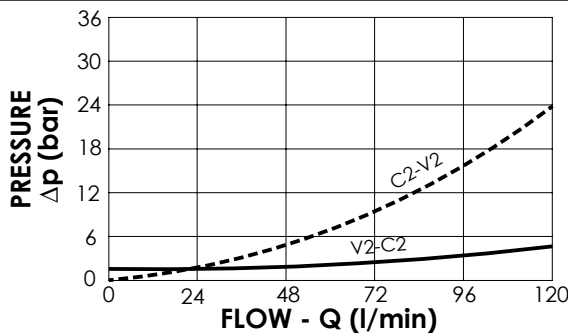

NOTES

Setting: at least 1.3 times the load induced pressure

ORDERING CODES

Quick code	Description	Pilot ratio	Main ports size	Standard setting (bar, Q=5 l/min)	Adjust. range (bar)	Pressure increase (bar/turn)
MN000010	MNDN-120-LLPV-08-G34-N300	8:1	V1,V2,C1,C2: G 3/4" T: G 1/2"; C3: G 1/4"	Start: 300 Brake: 120	100-300	111
MN000001	MNDN-120-LLPV-08-G34-N200	8:1	V1,V2,C1,C2: G 3/4" T: G 1/2"; C3: G 1/4"	Start: 180 Brake: 90	70-210	73
MN000018	MNDN-120-LLPV-03-G34-N300	3:1	V1,V2,C1,C2: G 3/4" T: G 1/2"; C3: G 1/4"	Start: 300 Brake: 120	100-300	111
MN000048	MNDN-120-LLPV-03-G34-N200	3:1	V1,V2,C1,C2: G 3/4" T: G 1/2"; C3: G 1/4"	Start: 180 Brake: 90	70-210	73

MOTION CONTROL

MNDN-200-LLPV

**SOFT STOP
DUAL SETTING
WITH BRAKE RELEASE**

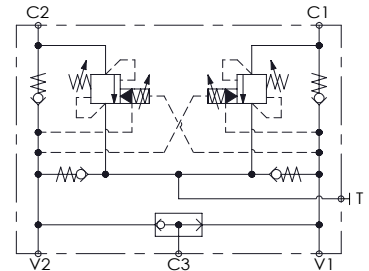
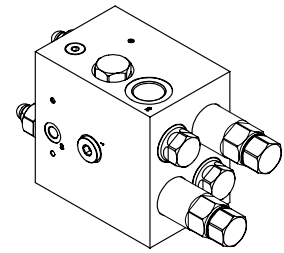
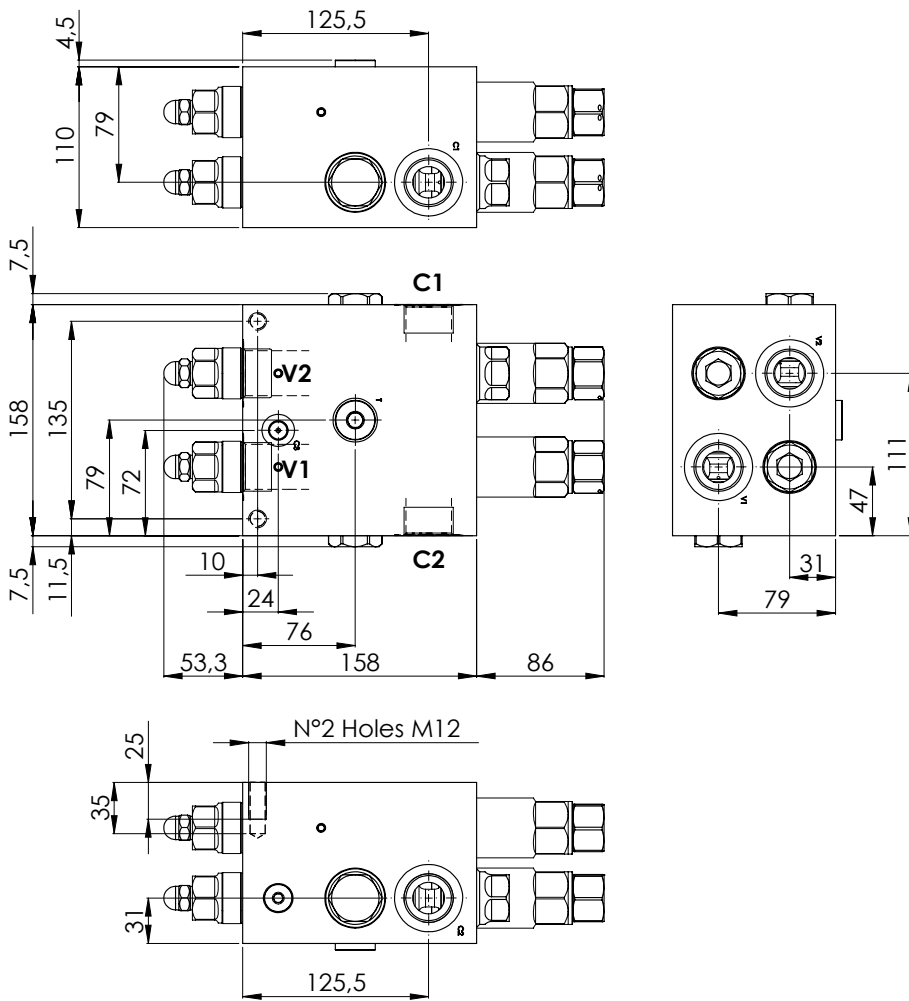

SPECIFICATIONS

Max. operating pressure:	300 bar
Rated flow:	200 l/min
Manifold:	Aluminium
Weight:	9,81 kg

NOTES

Setting: at least 1.3 times the load induced pressure

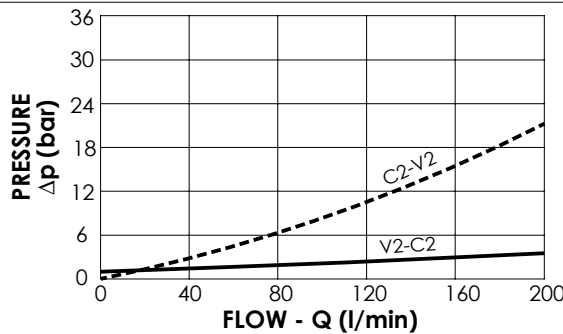

ORDERING CODES

Quick code	Description	Pilot ratio	Main ports size	Standard setting (bar, Q=5 l/min)	Adjust. range (bar)	Pressure increase (bar/turn)
MN000022	MNDN-200-LLPV-08-G10-N300	8:1	V1, V2, C1, C2 : G1" T : G1/2"; C3 : G 1/4"	Start: 300 Brake: 120	120-300	65



ATLANTIC
Fluid Tech

TECHNICAL

Specifications



1800-OILSOL
1800-645765

<https://oilsolutions.com.au/>

sales@oilsolutions.com.au

TECHNICAL SPECIFICATIONS

Modena, 05/04/2018

MATERIALS

CARTRIDGES AND INTERNAL COMPONENTS: Cartridge bodies are manufactured from high grade cold drawn steel bar, all of the external parts are zinc plated for longer durability in challenging environments. The valve's internal working parts are hardened and ground (or lapped) for maximum performance and durability.

MANIFOLDS: Cartridges, parts in body valve manifolds and integrated circuit blocks are manufactured from high strength aluminum bars and high quality steel. As a standard, steel manifolds are always zinc plated (Crome 3 treatment) whilst aluminum bodies can be anodized upon request. For complete specifications and compatibilities, please consult our Engineering department.

For pressures above 210 bar we recommend using steel bodies. In most cases the aluminum bodies are strong enough, but if transient peak pressures are frequently encountered, there is the possibility of fatigue cracks.

COILS: the external encapsulating material of our coils is made of class H thermoplastic compound as well as internal copper wire.

PORTS

The standard port dimension on our valves, when not flanged, is BSPP size, ranging normally between G1/4" and G1-14". SAE 'O' Ring and NPT ports are available on request, as well as special flange dimensions.

SEALS, BACK-UP RINGS AND SLIDE RINGS

We use Acryl-Nitrile Butadiene NBR (BUNA-N) seals as standard for temperatures between -30°C and +100°C. Viton seals or other compounds are available on request.

Back-up rings and slide rings are made of reinforced poly-tetrafluoroethylene (PTFE).

STORAGE OF NEW VALVES

The valves must be stored in their original plastic envelopes or cartoon boxes. In a dry, dust-free atmosphere, free of corrosive agents, with a low moisture content and no large variations in temperature. They should not be exposed to direct sun light or sources of heat or ozone (as this could cause the fast wearing of valve seals). Storage temperature must be between -20°C and +50°C.

HANDLING AND INSTALLATION OF VALVES

We recommend the installation and the use of our valves be carried out by expert and qualified people with perfect knowledge of the product. AFT will not be responsible for improper use of its products. For any clarification please contact AFT sales network.

The valve handling must be done in accordance with the weight of the box and of the valve itself, for more information please refer to your Country rules. Valves over a specific weight are equipped with threads where a hook can be installed; in this way the valve can be attached and lifted using mechanical devices.

FLUIDS AND WORKING TEMPERATURE RANGE

The recommended fluid is mineral oil based fluid, such as HL type (DIN 51524 part 1) or HLP type (DIN 51524 part 2) with an operating viscosity between 10 and 380 cSt. High viscosity and low temperatures may lead to a slower valve response than in warm oil conditions.

For water based fluids, such as 95/5 and 60/40 emulsions, please consult AFT sales network.

Fluid working temperatures should be maintained between -30°C and +100°C. For other working conditions, please consult AFT sales network.

FUNCTIONAL TEST

All the valves we sell are subjected to functional tests. The tests are carried out using ISO VG 46 hydraulic oil (viscosity of 46cSt at 40°C) and with oil temperature between 30 and 40 °C.

FILTRATION

Our valves are precision-machined mechanical components: the majority of valves failures (during normal working conditions) occurs due to hydraulic circuit contamination. We recommend the following filtration levels:

SYSTEM WORKING PRESSURE:	NOM. FILTRATION	CONTAMINATION CLASS:	
> 250 BAR:	10 µm	ISO 4406: 17/14	NAS 1638: 8
BETWEEN 100-250 BAR:	15 µm	ISO 4406: 18/14	NAS 1638: 9
< 100 BAR:	25 µm	ISO 4406: 19/15	NAS 1638: 10-11

INTERNAL LEAKAGE

Many of our valves have a leak proof seat design: this means that the maximum allowed oil leakage value is 1 cc/min (about 15-20 drops/min) measured with 46cSt oil at 40°C at the maximum permitted pressure. However, normal leakage is found to be less than 10 drops/min and tends to decrease or disappear after few seconds of rest. These are within the acceptable limits, note however that each type of valve has different performances depending on its design: please refer to our Engineering dept. for information about each valve type.

VALVE SETTING AND TAMPERPROOF DEVICES

SETTING: Our valves are supplied Factory set as stated on the corresponding catalogue page. The adjustment range and maximum setting figures shown on the catalogue are the safe limits according to each valve specific design: in the majority of cases higher or lower values can be attained. Any setting changes should be approved in writing prior by our Engineering dept. Any setting change must be carried out using an appropriate gauge or pressure/flow measuring equipment.

TAMPERPROOF: The majority of our cartridges and parts in body valves have the possibility to be equipped with a plastic tamperproof cap to prevent any undesired modification of valve setting: please refer to each catalogue page for the choice of the correct cap. On request, valve can be supplied already Factory set and sealed.

CARTRIDGE VALVE INSTALLATION

The correct machining of cavities is critical in ensuring the best performance of our cartridges. Cavity tools are available for sale and cavity drawings can be found in the specific section of our catalogue or requested from our Engineering dept.

To correctly install cartridges into their cavity, please follow this procedure:

- Check that external seals and back-up ring are correctly fitted and without damage;
- Ensure the cavity and cartridge body are clean and without any visible contamination;
- If necessary, immerge cartridge body into clean oil to take away any impurity and to lubricate the seals;
- Screw the cartridge into its cavity by hand, until mechanical contact is reached, being sure that during tightening that there is no abnormal friction between the cartridge and its cavity;
- Tighten the cartridge with a calibrated torque wrench applying the correct torque as specified on the corresponding catalogue page.

TORQUE FIGURES

So as to ensure correct cartridge behavior and to prevent any internal friction the correct torque must always be applied when fitting cartridges into their cavities: the correct torque values can be found on each cartridges' catalogue page.

COILS

ED RATE: All our coils are rated ED 100%, they can remain 100% energized through out the working cycle, provided the nominal voltage and maximum ambient temperatures are not exceeded.

TEMPERATURE CLASS: As standard the encapsulating material and copper wire are rated CLASS H: this means that the ambient temperature + temperature rise due to coil operation cannot exceed 180 °C. Class F coils are available on request (maximum 155 °C). The external surface of the coil can easily reach very high temperatures after long energizing period (80-100°C): Particular care must be taken to avoid accidental injuries to workers and operators. To prevent premature burning of the coils, it is requested that coils are installed in such a way to aid air ventilation around them and thus preventing excessive heating of the surrounding ambient.

IP PROTECTION CLASS: The standard insulation class of our coils is IP65, provided that all the seals between coil and solenoid cartridge tube/nut and between coil and connector are correctly fitted. Coils with Deutsch connector are rated with an IP69K insulation class.

INLET VOLTAGE: Our coils normally accept inlet voltage fluctuations of between $\pm 10\%$ without any compromise to normal functionality (unless specified on the coil catalogue page). If specific inlet voltages are required, please refer to our Engineering dept.

POWER SUPPLY: Our solenoid operated cartridges are designed to operate with DC (direct current) power supply: in case of AC (alternate current) applications, please apply between power supply and coil a current rectifier and use the proper RAC (rectified alternate current) coil.

ENVIRONMENTAL CARE AND PRODUCTS DISPOSAL

AFT products are made mainly with metallic materials; steel, aluminum, cast iron and plastic materials (ABS, PTFE, NBR) that can be recycled after being cleaned of hydraulic fluids if present.

Our packaging materials are made mainly of paper, cardboard, wood, plastic and polyethylene which can be recycled after being cleaned from hydraulic fluids if present.

Hydraulic fluids must be disposed of in accordance with the laws and procedures of each country.

During handling, installation and use it is necessary to avoid the dispersion of hydraulic fluid into the environment, in case of accidental dispersion it is necessary to follow your local rules.

Engineering Department





ATLANTIC
Fluid Tech

GENERAL

Terms of Supply



1800-OILSOL
1800-645765

<https://oilsolutions.com.au/>

sales@oilsolutions.com.au

GENERAL TERMS OF SUPPLY – OUTLINE AGREEMENT

San Cesario Sul Panaro (MO): 31/10/2011

1 SUBJECT

The present general terms of supply (or outline agreement) have been drafted to regulate all the supply relations existing between Vendor and Customer, which will be conducted at the conditions hereinafter described and/or on the basis of any additional agreements specifically entered into between the parties.

If these general terms of supply should contain any clauses or prescriptions that conflict with specific conditions of supply agreed between the parts, these latter shall prevail.

2 CUSTOMER ORDERS

The Customer's orders must be transmitted to the Vendor in written form (also via fax, or using telecommunications and electronic means) and must contain the following information:

- a) date and place of issue of the order;
- b) exact denomination of the Customer company and its complete address;
- c) a reference to the relative offer made by the Vendor company (if such an offer exists);
- d) complete Vendor's identification code, with a description of the product ordered if necessary and the relative technical specifications of all the products to which the order refers;
- e) the required quantities;
- f) the agreed prices (if available);
- g) the quality requirements with which the Vendor must comply in execution of the order;
- h) the signature of an authorised representative;
- i) the required term of delivery;
- l) terms of payment;
- m) shipping agent.

Orders are intended as accepted when the relative order confirmation duly signed by the Vendor arrives at the registered address of the Customer, or if such a document is not forthcoming, orders will be considered to be confirmed by the Vendor at the terms of supply specified herein if they are not explicitly refused in writing within the term of 10 working days from the date of the order in question.

2.1 PRICES

The prices established by the Vendor and/or agreed upon with the Customer shall remain fixed for the entire period of the order or for the agreed period; said period shall not be subject to modification except in the presence of exceptional events and/or causes of force majeure (e.g. uncontrolled price increases of raw materials or energy, etc.); in such cases new agreements will be entered into with customers.

3 EXECUTION OF THE CONTRACT OF SUPPLY - AMENDMENTS

- The terms of the contract of Supply are intended as final and executive when:
- the Customer transmits to the Vendor the purchase order in written form relative to the ordered product, specifying the requirements set down in heading 2 above;
 - the Vendor has issued its Order confirmation and transmitted it to the Customer, or has failed to refuse the order in writing within 10 working days from the date of the order in question (See heading 2).

Once the contract has been signed, it must be fully and duly executed by the parties. Any amendments or cancellations of the contract can only take place further to the stipulation of agreements between the parties (Vendor and Customer) that take into account, on a reciprocal basis, any possible compensation for reimbursement of expenses sustained (materials, labour, etc.) to be paid to the more diligent party that receives such a request for amendment or cancellation.

In any event, the Customer is entitled to request modifications relative to orders it has already issued in relation to the quantity and/or characteristics of the ordered products, by means of the issue and transmission to the Vendor of a specific order variant, which shall be construed as implicitly accepted by the Vendor if this latter fails to raise any objections within the term of 10 working days from the receipt of such an order variant.

The execution of the contract of supply can be suspended and/or cancelled, also without notice to the customer, due to causes of force majeure (e.g. grave natural disasters, social unrest, epidemics, etc.) that are outside the Vendor's control.

4 TECHNICAL MODIFICATIONS

Except in the presence of contrary agreements with Customers, the Vendor can make technical modifications to the product specifications without notice; in any event, the Vendor undertakes to execute customer orders/contracts that are already confirmed without applying any modifications and/or anyway guaranteeing interchangeability of the relative products.

5 PRODUCT QUALITY AND VERIFICATION OF CONFORMITY

All the products are subject to the necessary checks/tests in the various production phases in order to guarantee conformity with the specifications and calibrations indicated in the catalogues, drawings, and/or technical datasheets; moreover, the Vendor's production process complies with the Quality System requirements defined by UNI EN ISO 9001, certified by an accredited Institute. The Customer is entitled make visits to and to carry out quality audits at the Vendor's plant after arranging an appointment for such occasions.

Because of the large range of technical features and operating conditions of the equipment manufactured by the Customer, the Vendor shall not assume any liability for the results of tests performed by third parties. The Customer is therefore responsible for the final choice of the valve and for the adoption of all the measures required to achieve the required functional and safety specifications on the system in which the valve is to be installed, in addition to the compliance with any specific standards applicable to the system in question.

In the event of nonconforming products the responsibility for which can be attributed to the Vendor, in addition to the warranty actions provided for in the following article 6, the Customer can demand that the Vendor perform the necessary corrective actions in order to improve its level of quality rapidly.

5.1 "FIRST SPECIMENS" CHECK

For new special products made to Customer's specifications or customised to a significant extent with respect to the equivalent standard products, when so requested by the Customer the Vendor can, further to prior agreement with the Customer, carry out checks on "First Specimens"; this procedure entails the supply of "Prototypes or Specimens" of Products accompanied by Test Certificates detailing dimensional checks and functional tests evaluating diverse technical aspects.

In this case the Customer's validation of subsequent supplies must be performed on the basis of the "First Specimens".

6 WARRANTY

The Vendor provides a warranty to the first Customer covering its valves against defects in material or workmanship for a period of 24 months from the time of first assembly, provided said first assembly takes place within 6 months from the date of manufacture as marked on the valve, and provided the valve is installed and utilised in accordance with the conditions of use prescribed by the Vendor and/or in compliance with the standards adopted in accordance with industrial best practices. Seals and O-rings are expressly excluded from the warranty.

This warranty is applicable exclusively to the first Customer/Purchaser of the Vendor's products and is not transferable.

In the event that the Customer considers that the goods or a part of the goods are defective for causes attributable to the Vendor, the Customer shall signal/protest the presence of the alleged defects by sending a detailed written report, thereby allowing the Vendor to verify the effective existence of the claimed defects/flaws by means of inspections performed by its technical personnel.

Having ascertained that the claimed defects are effectively present and having accepted that they are attributable to the fault of the Vendor, this latter undertakes to repair or replace the goods in question in a reasonable time interval and/or inform the Customer of the cause of such defects.

This warranty is not applicable to products that have been subject to conditions of contamination in the customer's hydraulic circuit, or to products that are incorrectly utilised or subject to tampering performed without the Vendor's supervision or authorisation.

The Vendor's warranty does not envisage pecuniary compensation or credit notes in respect of defective material; specifically, the Vendor shall not be held responsible under any circumstances for loss of earnings, costs of disassembly and reassembly of the product, for any damages connected with such an operation, and for any whatsoever cost relative to the installation of the repaired or replaced valves, including the costs arising in relation to system outages.

If the product supplied is to be assembled in plants potentially capable of causing third party damages of a magnitude that is significantly greater than the price of the product, it is the Customer's responsibility to adopt all the possible safety measures to avoid any such damage, since it is aware that series production of valves at market prices leads to the risk, albeit negligible, of the possible presence of defective parts.

If the Customer embarks on a recall or remediation campaign of its own machines, on any whatsoever market, in order to replace or repair parts that have been ascertained to be defective, this action will be undertaken on the basis of bilateral agreements to be defined.

If the Customer is subjected to legal proceedings for "civil product liability" or if it is accused of violation of legal prescriptions connected to the Vendor's products, the Customer must inform the Vendor immediately of such a situation, and the Vendor shall participate in the analysis of the problem in collaboration with the Customer.

Wherever considered necessary, specific agreements can be stipulated between Customer and Vendor as an alternative to the foregoing warranty procedures.

6.1 SUPPLY QUALITY OBJECTIVES

Specific supply quality objectives may be established in certain cases, to be agreed with Customers; in such cases the Vendor undertakes to cooperate with the Customer in order to define all the aspects necessary to fulfil the objectives in question, and the necessary actions that must be undertaken when such objectives are not achieved.

The possibility of economic recourse or penalties applied by the Customer in relation to the value of the supplies is not contemplated under any circumstances.

7 TECHNICAL ASSISTANCE

The Vendor guarantees to the Customer its availability to perform joint analyses, free of charge, of any defects reported by end users, also when such analyses are carried out on the Customer's site; in this case, if the defectiveness is attributable to the responsibility of the Customer, the Vendor will issue a debit note relative to its services rendered. When the Customer requires the assistance of the Vendor's technical personnel on its sites it must make a written request to this effect (which can be transmitted also by e-mail or fax).

8 PRESCRIPTIONS OF INTENDED USE.

The Customer is expressly prohibited from using the products sold by the Vendor for purposes other than those set down in the offer or in the catalogues.

Specifically, the Vendor's Dealers or Agents are not authorised to approve the use of the products supplied for the following applications:

- systems for road vehicles for the transport of passengers or goods and subject to safety Standards and Directives, such as (without limitation) steering systems and brake systems
- aircraft or spacecraft;
- military equipment;
- rescue or emergency equipment or vehicles;
- systems to be used in conjunction with atomic installations;
- systems for use in explosive or otherwise hazardous environments.

If the Customer intends to use the goods supplied for any applications falling into one or more of the above categories or other similar categories, or for any applications other than those expressly described in the documentation, or in the presence of doubts concerning the intended application, it must seek prior specific approval directly from the Manufacturer and await the receipt of written authorisation for the intended application before proceeding.

Any damage suffered by the Customer or third parties arising from failure to comply with the terms of the prescriptions as at the foregoing subsections, or due to the failed observance of the specifications/directions for use supplied by the Vendor in the pages of its catalogue or in the assembly drawings, will be borne entirely by the Customer.

9 OBLIGATION OF DILIGENCE OF THE CUSTOMER IN THE PREVENTION OF DAMAGE IN THE CONTEXT OF ITS OWN PRODUCTION PROCESS.

If the product is utilised in a production process in such a way that any defects in the supplied product could give rise to substantial damages to the Customer or third parties deriving from production plant downtimes, the Customer undertakes to acquire a sufficient number of the parts in question to replace any faulty parts, and further undertakes to engineer the production process in such a way that such replacements can be carried out quickly and easily. In any event, the Vendor undertakes to repair or replace any parts that are found to be defective due to causes for which it is ascertained to be responsible.

10 DISCREPANCIES BETWEEN THE CONTENTS OF THE CUSTOMER OFFER AND THE PRESCRIPTIONS OF THE PRESENT TERMS OF SUPPLY.

Any aspects or conditions specified in the Customer Order that depart from contents of the present of terms of supply will be disregarded and construed as automatically replaced by the terms and conditions stated herein.

11 EXECUTION OF SUPPLIES ARRANGED PRIOR TO THE ACCEPTANCE OF THESE GENERAL TERMS.

If the supply is executed before the present general terms have been accepted by the Customer, the contract of supply shall be construed as having been entered into at the general terms and conditions specified on the back of the invoice and the delivery note, unless the Customer returns the goods to the Vendor, carriage forward, in exactly the same condition in which they were shipped within the term of 5 working days from the date of their receipt.

12 DELIVERY - DOCUMENTATION

Except in the presence of contrary agreements entered into between the parties, reference must be made in respect of the terms of delivery, to the terms specified by the Vendor in its Order Confirmation. At the order confirmation stage the Vendor can propose changes to the requested delivery date on the basis of its internal production requirements. The Customer reserves the right to accept or refuse the proposed modifications on the basis of its own requirements.

Any delivery terms specified in the Customer's orders or in other written documents exchanged between the parties shall not be considered to be binding except in the presence of a specific written agreement to such effect.

If the Customer intends to rescind from the contract and/or advance claims for compensation for damages further to failed observance of the terms of delivery, it must notify the Vendor expressly of such intentions at the time it transmits the order, and it must request an explicit confirmation from the Vendor specifying that it accepts such conditions.

All shipments will be sent with an attached delivery note bearing the following information: the order number, vendor's product code and Customer code (when required and present), description, quantity, identity of the shipping agent, and details concerning the transport means, number of items of packing, gross weight, etc.; the availability of this information serves to allow rapid correlation of the incoming goods with the shipping documents.

The Customer undertakes to inspect the goods delivered within and no later than 10 (ten) days from the time of receipt and it will automatically waive its rights to claim for missing items or manifest defects of the goods if it fails to declare such circumstances within the same 10 (ten) days from the time of receipt.

13 TRANSPORT

Except in the presence of contrary written agreements between the parties, the means of transport and the carrier will be chosen by the Customer.

Transport costs are charged to the Customer, which is required to refund them to the Vendor in the event that this latter party is obliged to pay them in advance on the Customer's account.

If the Customer fails to specify the required carrier and means of transport, these aspects can be chosen freely at the discretion of the Vendor, which will stipulate the transport contract in the name of the Customer and on the account of this latter.

Whether the carrier is chosen by the Customer or whether it is chosen by the Vendor in the name of and on the account of the Customer, the goods will be transported entirely at the

risk and responsibility of the Customer, which can recourse directly to the carrier in the event of damage sustained during transport. The Customer is not entitled to make any claims against Vendor in such respects

14 PAYMENT

The terms and methods of payment for the supplies are specified in the Vendor's Offers and in the Customer's orders; when such orders are accepted by means of an order confirmation they become an integral and essential part of the supply contract.

Unless otherwise agreed, payment of the price of the supply must be made using the domicile and methods indicated by the Vendor. In the case of a delayed payment arrears interest will be applied in the measure of the Euribor 365 days rate increased by 4% per annum.

The Customer is not entitled to withhold sums from payments due to the Vendor for any whatsoever reason unless such action has been previously agreed upon and approved in writing by the Vendor.

15 EXTENDED PAYMENT – OWNERSHIP RESERVATION

If the payment is extended, the sale shall be understood to have taken place with reserved ownership pursuant to the terms of articles 1523 et seq. of the Italian civil code without any further provisions having to be taken successively. The costs involved in establishing proof of reserved ownership as specified in art. 1524 of the Italian civil code shall be borne entirely by the Customer.

16 FORM OF THE PROPOSAL, THE ACCEPTANCE AND ANY WHATSOEVER OTHER LEGALLY SUBSTANTIAL COMMUNICATION

The proposal, acceptance, any possible claims, and any other legally substantial communications must be written and signed in a legible manner. Such communications can be transmitted by any means, including fax and e-mail. In this latter eventuality the e-mail message must bear the author's name at the foot of the page.

17 CIVIL LIABILITY INSURANCE

The Vendor undertakes to take out and maintain a "Civil Product Liability Insurance" policy. On the request of the Customer, the Vendor will produce the documents relative to such an insurance policy.

Any accidents resulting in damage to third parties in which the Vendor's products are involved and which could give rise to product civil liability claims for compensation, must be communicated with the maximum promptness to the Vendor so that this latter can participate in the relative inquiry, also through its appointed technical expert, starting from the stage of the initial investigations.

18 CONFIDENTIALITY

The Vendor and the Customer reciprocally guarantee the confidentiality of all the information, data, and all documents that they exchange during the course of their business relations.

In particular documents which are sent to the Customer like drawings, technical specifications, test reports, etc. and containing manufacturing or functional data of the products, have to be considered property of the Vendor and they cannot be disclosed or passed to third parties without the written consent of Vendor's Management.

19 ACCEPTANCE OF THE GENERAL TERMS OF SUPPLY – AMENDMENTS OR CANCELLATIONS

These General Terms of Supply can be transmitted to the Customer in the following ways:

- DIRECTLY, during the stipulation of a bilateral agreement or contract;
- INDIRECTLY, attached to the Vendor's Order confirmations.

In both cases they are considered to have been TACITLY ACCEPTED by Customers when no contrary communication is received within the term of 15 days from the date of receipt of the terms.

If the Customer intends to amend or rescind from these terms of supply it must provide the Vendor with written notice to this effect at least 3 months before the relative amendments or withdrawal are to take effect.

20 APPLICABLE LAW.

For all matters that are omitted from the present agreement the terms of supply shall be understood as being regulated by the relevant provisions of Italian Law.

If the Customer's domicile is in a foreign country, or in any cases in which the contract includes aspects of an "international nature", the present agreement and any disputes that should arise in relation to the same shall be subject to the provisions of Italian Law, with sole jurisdiction held by the Italian ordinary courts in the competent law court of Modena.

Atlantic Fluid Tech S.r.l. General Management