



ATLANTIC
Fluid Tech



OIL SOLUTIONS

**PO Box 38
Strathfieldsaye, VIC, 3551
1800 OIL SOL
1800 645 765**

sales@oilsolutions.com.au

www.oilsolutions.com.au

"For All Your Hydraulic Needs"

**SECTION
4**

Check Valves

SECTION 4

CHECK VALVES



Hydraulic scheme	Valve description	Valve type	Rated flow (l/min)	Max. pressure (bar)	Installation	Main port size or cavity type	Page
	CDVN-010-SSNS	Sphere type	10	350	Cartridge	VP000216	4.01.010
	CDVN-030-PSNR	Poppet type	30	350	Cartridge	VP000015	4.01.020
	CDVN-050-PSNR	Poppet type	50	350	Cartridge	SAE-08-2N	4.01.030
	CDVN-060-PSNR	Poppet type	60	350	Cartridge	VP000006	4.01.040
	CDVN-080-PSNR	Poppet type	80	350	Cartridge	SAE-10-2N	4.01.050
	CDVN-120-PSNR	Poppet type	120	350	Cartridge	SAE-12-2N	4.01.060
	CDVN-010-PAGS	Poppet type, monodirectional	10	350	Cartridge	G 1/8"	4.02.070
	CDVN-020-PAGS	Poppet type, monodirectional	20	350	Cartridge	G 1/4"	4.02.070
	CDVN-050-PAGS	Poppet type, monodirectional	50	350	Cartridge	G 3/8"	4.02.070
	CDVN-080-PAGS	Poppet type, monodirectional	80	350	Cartridge	G 1/2"	4.02.070
	CDVN-120-PAGS	Poppet type, monodirectional	120	350	Cartridge	G 3/4"	4.02.070
	CDVN-010-PANS	Poppet type, monodirectional	10	350	Cartridge	G 1/8"	4.01.080
	CDVN-020-PANS	Poppet type, monodirectional	20	350	Cartridge	G 1/4"	4.01.080
	CDVN-050-PANS	Poppet type, monodirectional	50	350	Cartridge	G 3/8"	4.01.080
	CDVN-080-PANS	Poppet type, monodirectional	80	350	Cartridge	G 1/2"	4.01.080
	CDVN-120-PANS	Poppet type, monodirectional	120	350	Cartridge	G 3/4"	4.01.080
	CDVN-015-SSNS	Sphere type, bidirectional	15	350	Insert	G 1/4"	4.01.090
	CDVN-030-SSNS	Sphere type, bidirectional	30	350	Insert	G 3/8"	4.01.100
	CDVN-050-SSNS	Sphere type, bidirectional	50	350	Insert	G 1/2"	4.01.110
	CDVN-070-PSNS	Sphere type, bidirectional	70	350	Insert	G 1/2"	4.01.120
	CDVN-120-PSNS	Sphere type, bidirectional	120	350	Insert	G 3/4"	4.01.130
	CDVN-030-PSNP-MF	Poppet type	30	350	Sleeve	G1/4"	4.03.140
	CDVN-050-PSNP-MF	Poppet type	50	350	Sleeve	G3/8"	4.03.140
	CDVN-090-PSNP-MF	Poppet type	90	350	Sleeve	G1/2"	4.03.140
	CDVN-150-PSNP-MF	Poppet type	150	350	Sleeve	G3/4"	4.03.140
	CDVN-200-PSNP-MF	Poppet type	200	350	Sleeve	G1"	4.03.140
	CDVN-250-PSNP-MF	Poppet type	250	350	Sleeve	G1"1/4"	4.03.140
	CDVN-030-PSNP-FF	Poppet type	30	350	Sleeve	G1/4"	4.03.150
	CDVN-050-PSNP-FF	Poppet type	50	350	Sleeve	G3/8"	4.03.150
	CDVN-090-PSNP-FF	Poppet type	90	350	Sleeve	G1/2"	4.03.150
	CDVN-150-PSNP-FF	Poppet type	150	350	Sleeve	G3/4"	4.03.150
	CDVN-200-PSNP-FF	Poppet type	200	350	Sleeve	G1"	4.03.150
	CDVN-250-PSNP-FF	Poppet type	250	350	Sleeve	G1"1/4"	4.03.150
	CDVN-010-DSNS	Disk type, bidirectional, not leak proof	10	350	Insert	G1/4"	4.04.160
	CDVN-030-DSNS	Disk type, bidirectional, not leak proof	30	350	Insert	G3/8"	4.04.160
	CDVN-070-DSNS	Disk type, bidirectional, not leak proof	70	350	Insert	G1/2"	4.04.160

CHECK VALVE

CDVN-010-SSNS

SPHERE TYPE

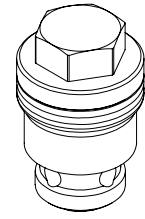
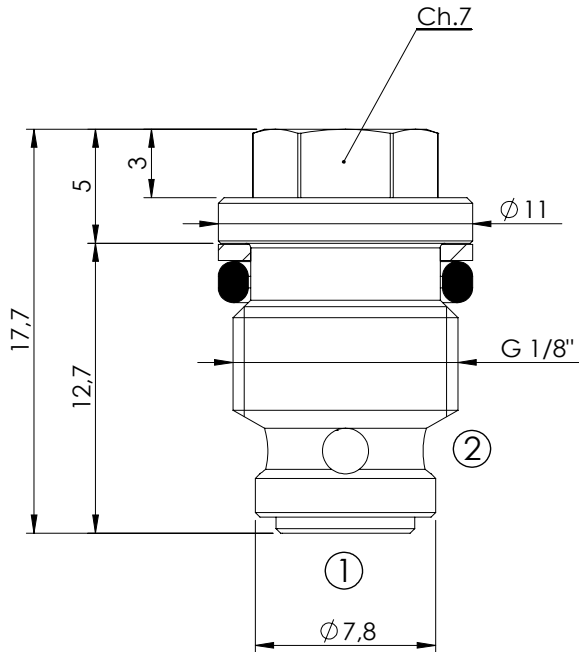

SPECIFICATIONS

Max. operating pressure:	350 bar
Rated flow:	10 l/min
Cavity:	VP000216
Weight:	0,01 kg

NOTES

Installation torque:	6.5 - 7 Nm
Seal kit:	RC700216

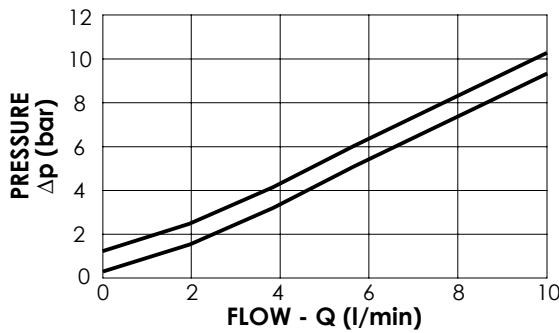

ORDERING CODES

Quick code	Description	Craking pressure (bar)	
CD000094	CDVN-010-SSNS-HN-216-N001	1,2	
CD000134	CDVN-010-SSNS-HN-216-N000	0,3	

CHECK VALVE

CDVN-030-PSNR

POPJET TYPE

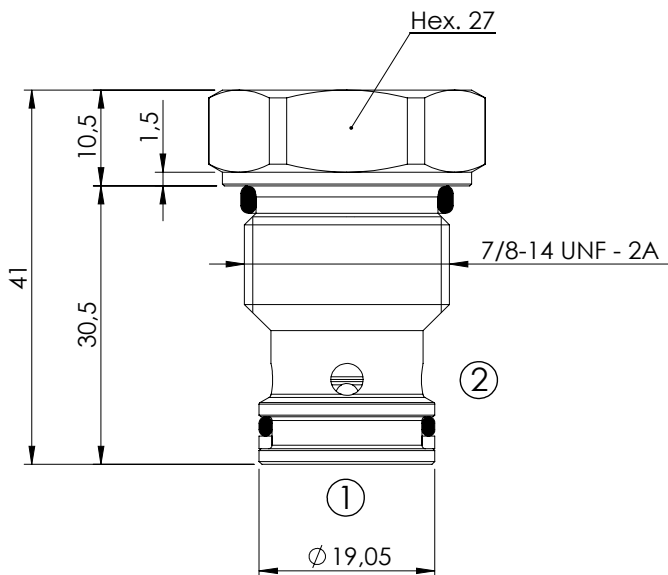
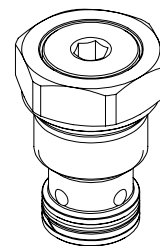

SPECIFICATIONS

Max. operating pressure:	420 bar
Rated flow:	30 l/min
Cavity:	VP000015
Weight:	0,11 kg

NOTES

Installation torque:	76 - 85 Nm
Seal kit:	RC700015

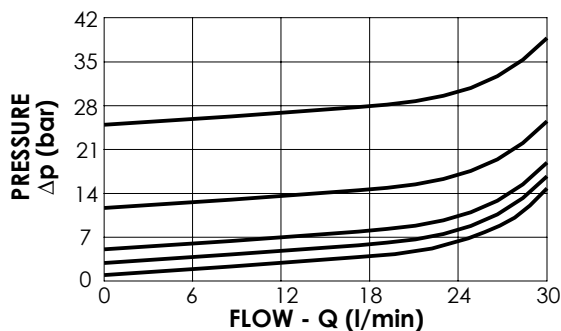

ORDERING CODES

Quick code	Description	Cracking pressure (bar)	Hardened Seat
CD000054	CDVN-030-PSNR-HN-015-N001	1	NO
CD000302	CDVN-030-PANR-HN-015-N001	1	YES
CD000195	CDVN-030-PSNR-HN-015-N003	3	NO
CD000303	CDVN-030-PANR-HN-015-N003	3	YES
CD000055	CDVN-030-PSNR-HN-015-N005	5	NO
CD000304	CDVN-030-PANR-HN-015-N005	5	YES
CD000056	CDVN-030-PSNR-HN-015-N009	9	NO
CD000132	CDVN-030-PANR-HN-015-N009	9	YES
CD000057	CDVN-030-PSNR-HN-015-N025	25	NO
CD000063	CDVN-030-PANR-HN-015-N025	25	YES

CHECK VALVE

CDVN-050-PSNR

POPET TYPE

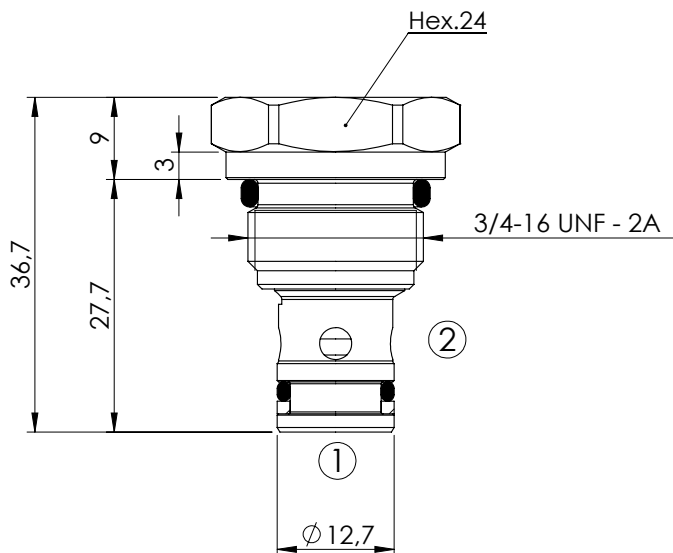
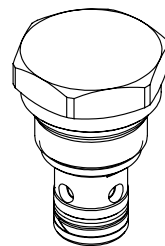

SPECIFICATIONS

Max. operating pressure:	350 bar
Rated flow:	50 l/min
Cavity:	SAE-08-2N
Weight:	0,06 kg

NOTES

Installation torque:	45 - 50 Nm
Seal kit:	RA700081

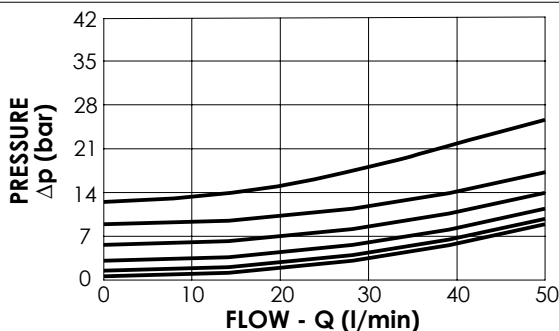

ORDERING CODES

Quick code	Description	Craking pressure (bar)	
CD000099	CDVN-050-PSNR-FN-S08-N000	0,35	
CD000024	CDVN-050-PSNR-FN-S08-N001	1	
CD000039	CDVN-050-PSNR-FN-S08-N003	3	
CD000269	CDVN-050-PSNR-FN-S08-N006	6	
CD000471	CDVN-050-PSNR-FN-S08-N009	9,5	
CD000070	CDVN-050-PSNR-FN-S08-N013	13	

CHECK VALVE

CDVN-060-PSNR

POPET TYPE

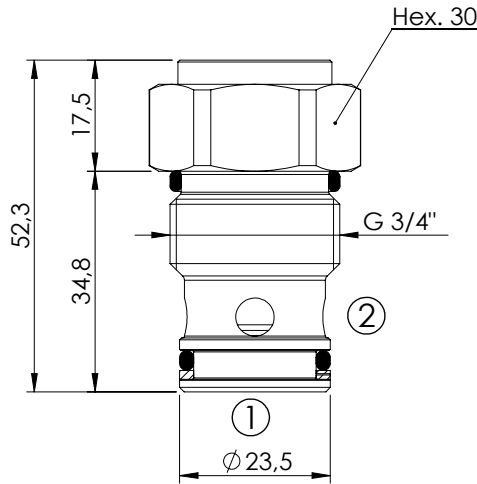
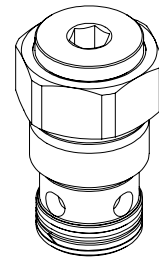

SPECIFICATIONS

Max. operating pressure:	350 bar
Rated flow:	60 l/min
Cavity:	VP000006
Weight:	0,18 kg

NOTES

Installation torque:	100 - 130 Nm
Seal kit:	RC700006

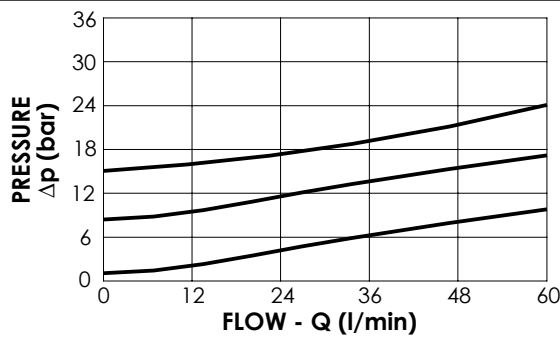

ORDERING CODES

Quick code	Description	Cracking pressure (bar)	
CD000019	CDVN-060-PSNR-FN-006-N001	1	
CD000020	CDVN-060-PSNR-FN-006-N009	9	
CD000075	CDVN-060-PSNR-FN-006-N015	15	

CHECK VALVE

CDVN-080-PSNR

POPPET TYPE

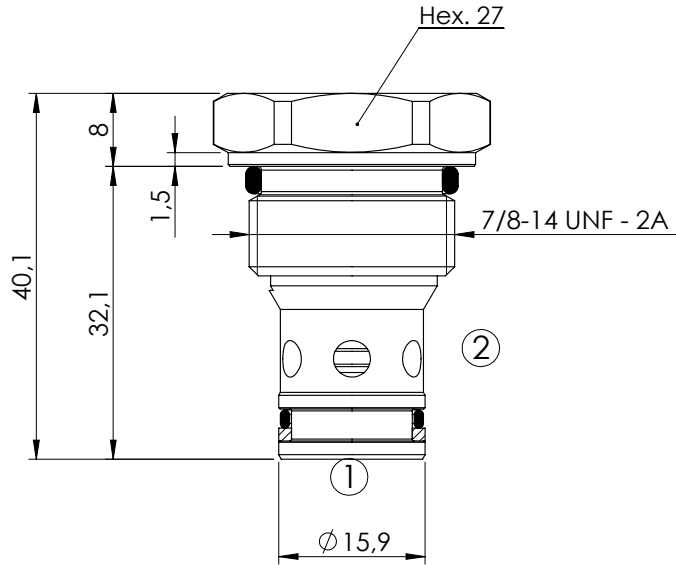
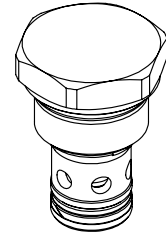

SPECIFICATIONS

Max. operating pressure:	350 bar
Rated flow:	80 l/min
Cavity:	SAE-10-2N
Weight:	0,09 kg

NOTES

Installation torque:	55 - 62 Nm
Seal kit:	RA700082

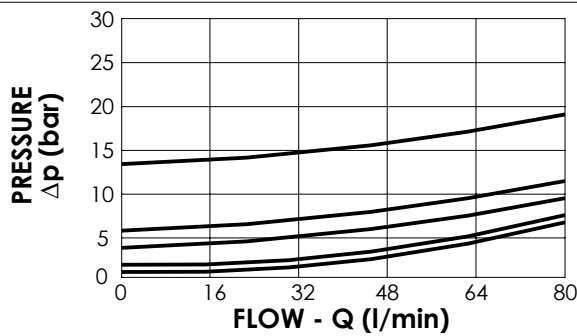

ORDERING CODES

Quick code	Description	Cracking pressure (bar)	
CD000100	CDVN-080-PSNR-FN-S10-N000	0,35	
CD000023	CDVN-080-PSNR-FN-S10-N001	1	
CD000169	CDVN-080-PSNR-FN-S10-N003	3,7	
CD000101	CDVN-080-PSNR-FN-S10-N005	5,5	
CD000082	CDVN-080-PSNR-FN-S10-N013	13	

CHECK VALVE

CDVN-120-PSNR

POPPET TYPE

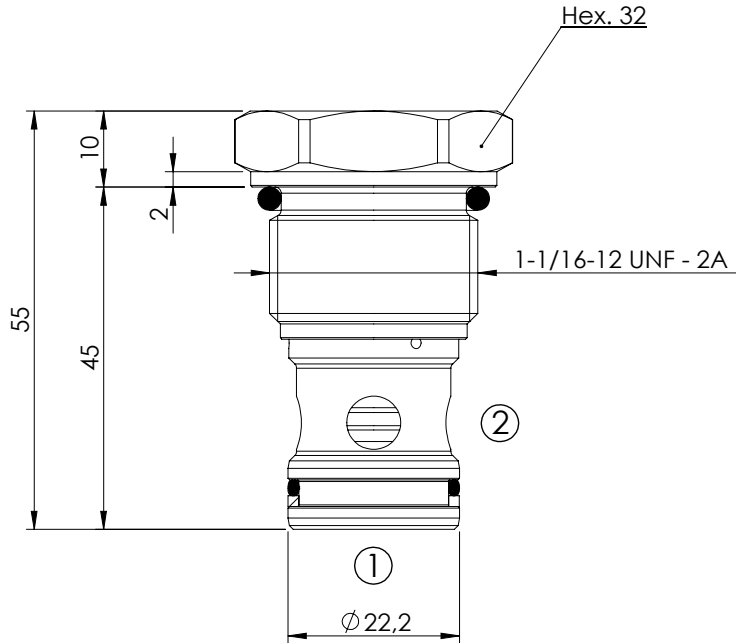
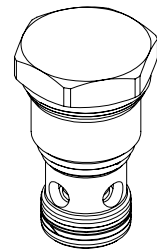

SPECIFICATIONS

Max. operating pressure:	350 bar
Rated flow:	120 l/min
Cavity:	SAE-12-2N
Weight:	0,18 kg

NOTES

Installation torque:	110 - 130 Nm
Seal kit:	RA700083

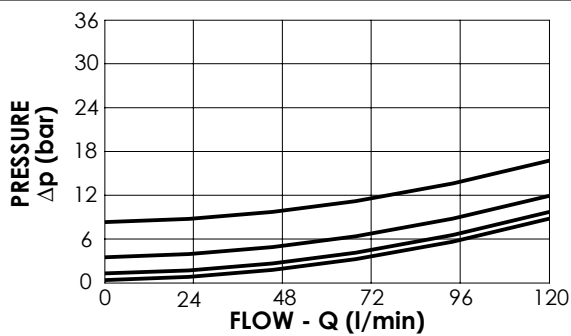

ORDERING CODES

Quick code	Description	Cracking pressure (bar)	
CD000444	CDVN-120-PSNR-FN-S12-N000	0,3	
CD000046	CDVN-120-PSNR-FN-S12-N001	1	
CD000310	CDVN-120-PSNR-FN-S12-N004	4	
CD000445	CDVN-120-PSNR-FN-S12-N008	8	

CHECK VALVE

CDVN-XXX-PAGS

MONODIRECTIONAL
POPET TYPE

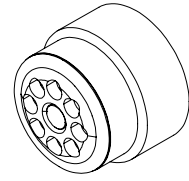
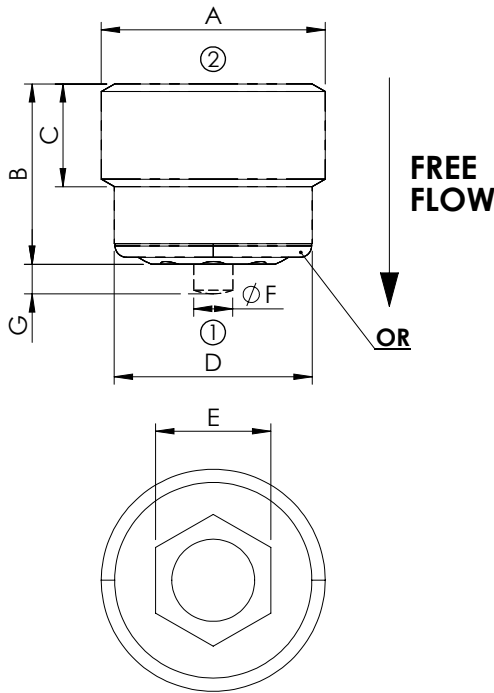

SPECIFICATIONS

Max. operating pressure: 500 bar

Quick code	A	B	C	D	E	F	G	OR
CD000179	G 1/8"	7,9	4,5	8,6	Hex. 5	1,7	1,3	6,00 x 1 N70
CD000180	G 1/4"	10,3	5,5	11,6	Hex. 7	2,0	1,3	9,00 x 1 N70
CD000181	G 3/8"	11,7	7,0	15	Hex. 6	2,7	2,0	11,00 x 1,5 N70
CD000182	G 1/2"	13,2	8,0	18,5	Hex.8	3,2	2,5	14,00 x 1,5 N70
CD000183	G 3/4"	17,1	10,5	24,0	Hex.12	5,5	3,8	18,77 x 1,78 N70

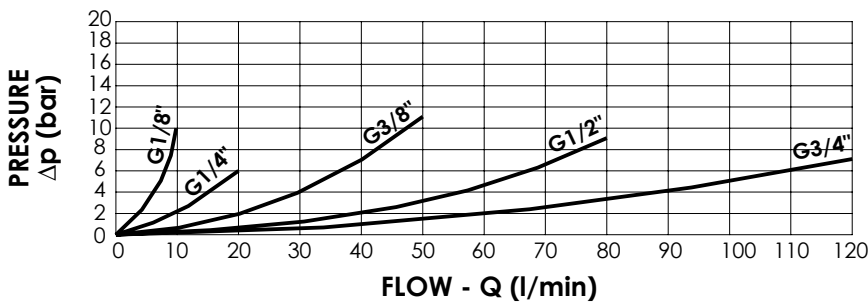

NOTES

Hardened seat and piston

ORDERING CODES

Quick code	Description	Cracking pressure (bar)	Rated flow (l/min)	Cavity	Installation torque (Nm)
CD000179	CDVN-010-PAGS-307-N001	0.1	10	VP000307 (G1/8")	8
CD000180	CDVN-020-PAGS-309-N001	0.1	20	VP000309 (G1/4")	15
CD000181	CDVN-050-PAGS-310-N001	0.1	50	VP000310 (G3/8")	20
CD000182	CDVN-080-PAGS-311-N001	0.2	80	VP000311 (G1/2")	40
CD000183	CDVN-120-PAGS-312-N001	0.1	120	VP000312 (G3/4")	80

CHECK VALVE

CDVN-XXX-PANS

MONODIRECTIONAL
POPPET TYPE

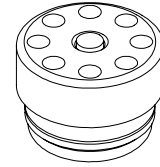
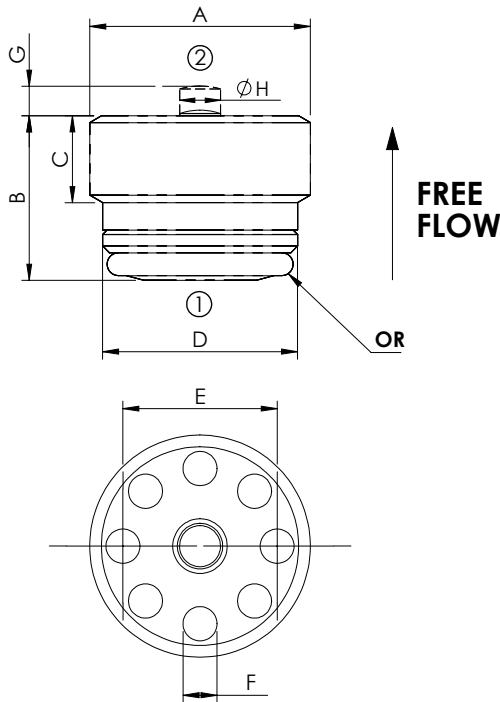

SPECIFICATIONS

Max. operating pressure: 500 bar

Quick code	A	B	C	D	E	F	G	H	OR
CD000173	G 1/8"	7,2	3,8	8,6	6,8	1,5	1,3	1,8	6.00 x 1 N70
CD000174	G 1/4"	9,0	4,5	11,5	8,8	2,2	1,5	2,4	9.00 x 1 N70
CD000175	G 3/8"	11,2	6,5	15,0	11,0	3,0	2,5	3,2	11.00 x 1.5 N70
CD000176	G 1/2"	13,5	8,0	18,5	14,2	3,8	3,0	4,0	14.00 x 1.5 N70
CD000178	G 3/4"	17,5	10,0	24,0	18,5	4,6	3,5	5,5	18.77 x 1.78 N70

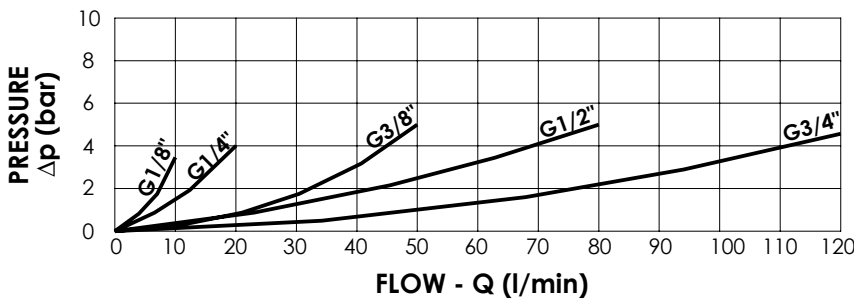

NOTES

Hardened seat and piston

ORDERING CODES

Quick code	Description	Cracking pressure (bar)	Rated flow (l/min)	Cavity	Installation torque (Nm)	Installation tool
CD000173	CDVN-010-PANS-307-N001	0,1	10	VP000307 (G1/8")	8	UM000390
CD000174	CDVN-020-PANS-309-N001	0,2	20	VP000309 (G1/4")	15	UM000391
CD000175	CDVN-050-PANS-310-N001	0,2	50	VP000310 (G3/8")	20	UM000392
CD000176	CDVN-080-PANS-311-N001	0,2	80	VP000311 (G1/2")	40	UM000393
CD000178	CDVN-120-PANS-312-N001	0,1	120	VP000312 (G3/4")	80	UM000394

CHECK VALVE

CDVN-015-SSNS

MONO-DIRECTIONAL
SPHERE TYPE

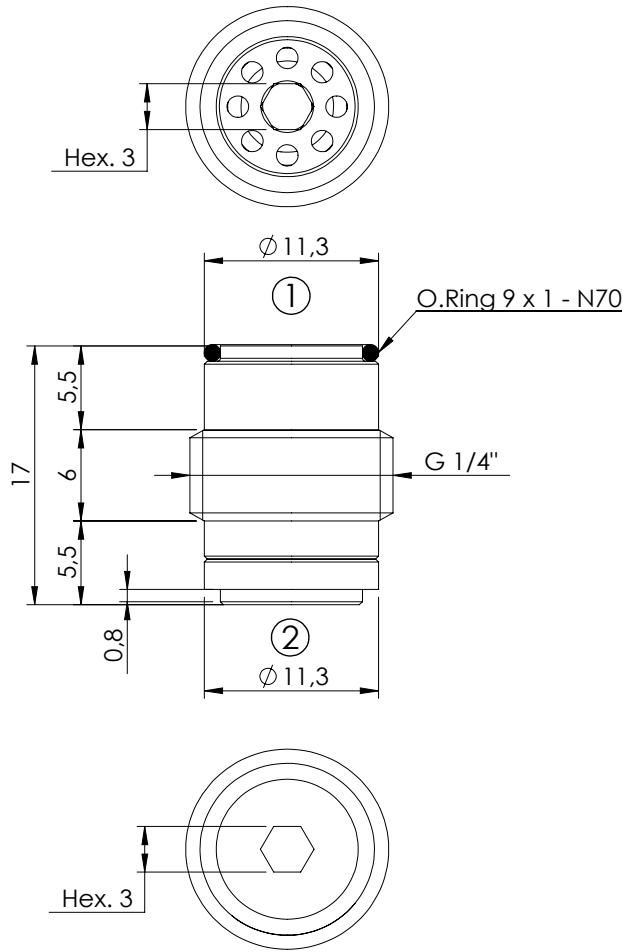
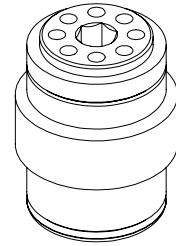

SPECIFICATIONS

Max. operating pressure:	350 bar
Rated flow:	15 l/min
Cavity:	VP000098
Weight:	0,01 kg

NOTES

Installation torque:	6 Nm
----------------------	------

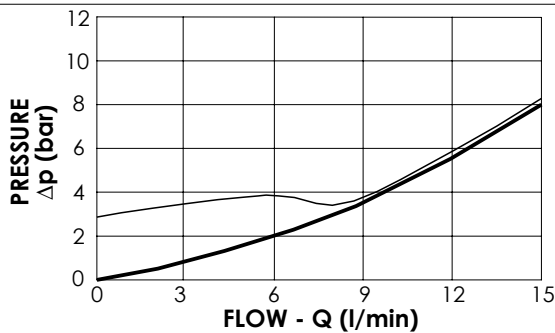

ORDERING CODES

Quick code	Description	Cracking pressure (bar)	
CD000026	CDVN-015-SSNS-FN-098-N003	3	
CD000043	CDVN-015-SSNS-FN-098-N000	0	

CHECK VALVE

CDVN-030-SSNS

MONO DIRECTIONAL
SPHERE TYPE

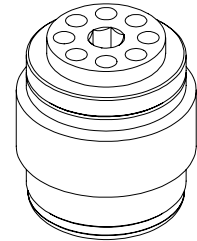
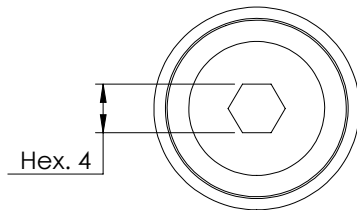
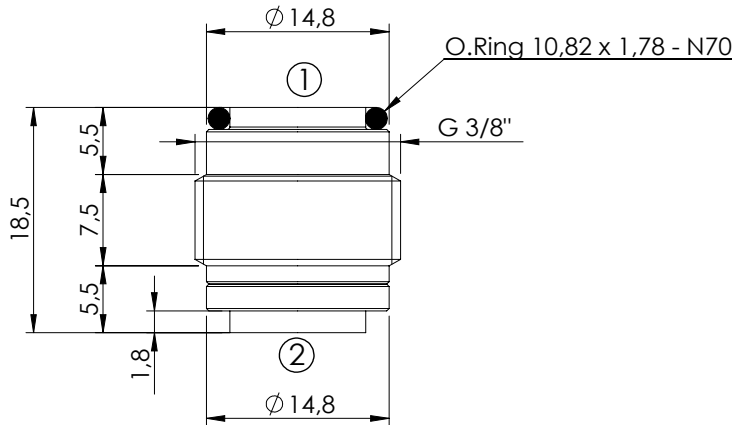
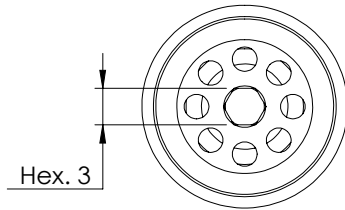

SPECIFICATIONS

Max. operating pressure:	350 bar
Rated flow:	30 l/min
Cavity:	VP000310
Weight:	0,02 kg

NOTES

Installation torque:	8 Nm
----------------------	------

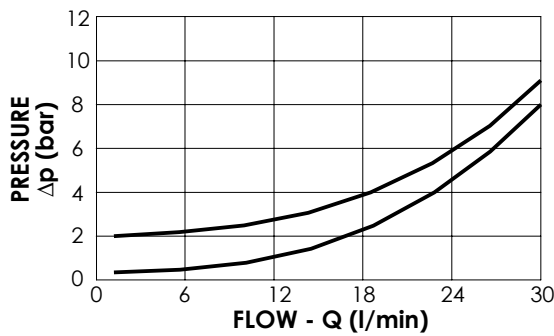

ORDERING CODES

Quick code	Description	Craking pressure (bar)	
CD000029	CDVN-030-SSNS-FN-310-N002	2	
CD000058	CDVN-030-SSNS-FN-310-N000	0	

CHECK VALVE

CDVN-050-SSNS

**BIDIRECTIONAL
SPHERE TYPE**

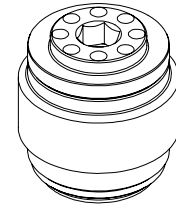
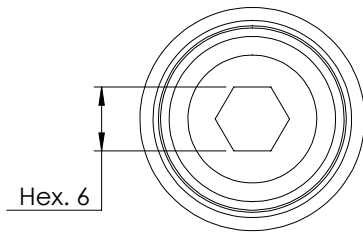
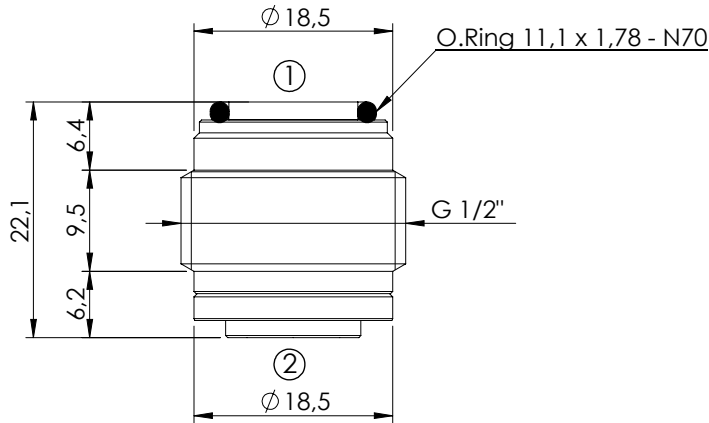
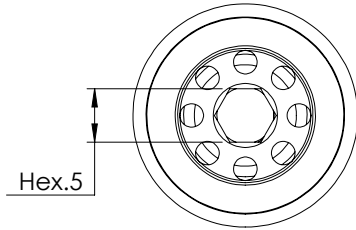

SPECIFICATIONS

Max. operating pressure:	350 bar
Rated flow:	50 l/min
Cavity:	VP000158
Weight:	0,04 kg

NOTES

Installation torque: 25 Nm
 Bidirectional installations.
 Fit O-Ring to side first inserted in cavity.

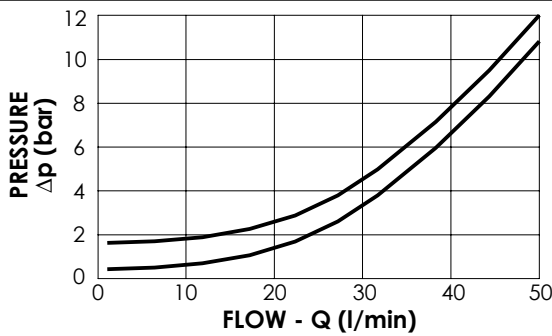

ORDERING CODES

Quick code	Description	Craking pressure (bar)	
CD000098	CDVN-050-SSNS-FN-158-N002	1,5	
CD000059	CDVN-050-SSNS-FN-158-N000	0	

CHECK VALVE

CDVN-070-PSNS

BIDIRECTIONAL
POPPET TYPE

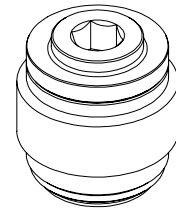
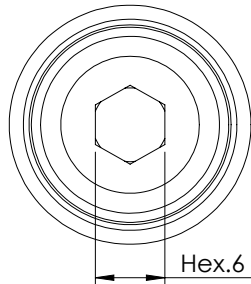
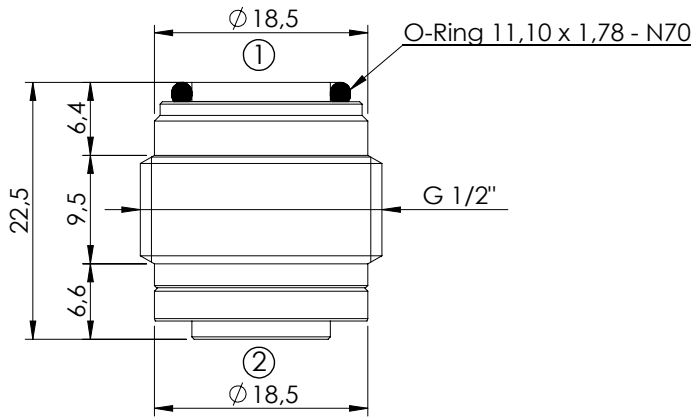
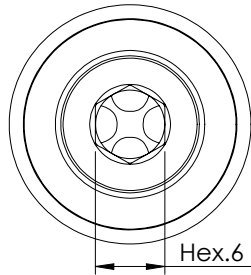

SPECIFICATIONS

Max. operating pressure:	350 bar
Rated flow:	70 l/min
Cavity:	VP000158
Weight:	0,04 kg

NOTES

Installation torque: 25-30 Nm

The valve can be assembled in both ways, OR to be placed only on the side first introduced in the cavity

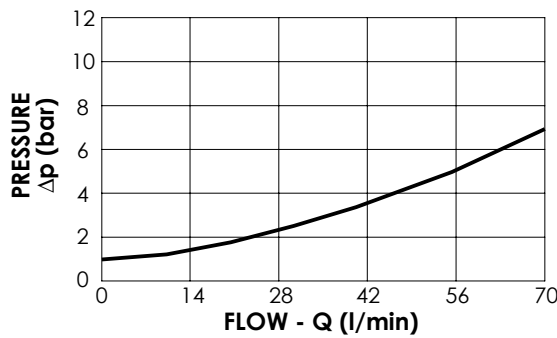

ORDERING CODES

Quick code	Description	Cracking pressure (bar)	
CD000107	CDVN-070-PSNS-FN-158-N001	1	

CHECK VALVE

CDVN-120-PSNS

**BIDIRECTIONAL
POPPET TYPE**

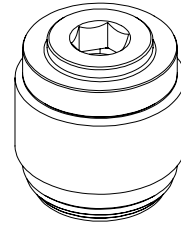
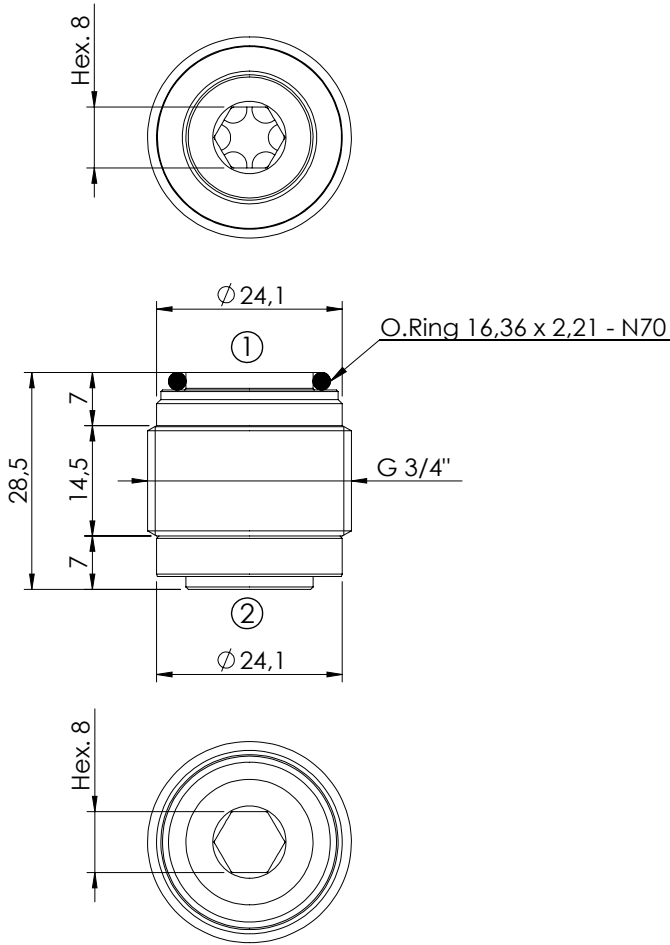

SPECIFICATIONS

Max. operating pressure:	350 bar
Rated flow:	120 l/min
Cavity:	VP000202
Weight:	0,08 kg

NOTES

Installation torque: 60 - 75 Nm

The valve can be assembled in both ways, OR to be placed only on the side first introduced in the cavity

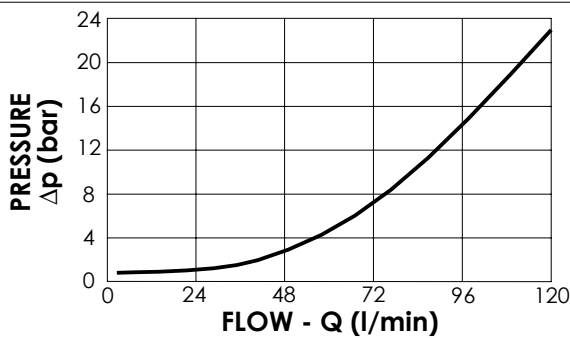

ORDERING CODES

Quick code	Description	Cracking pressure (bar)	
CD000106	CDVN-120-PSNS-FN-202-N001	1	

CHECK VALVE

CDVN-XXX-PSNP

SLEEVE
POPPET TYPE

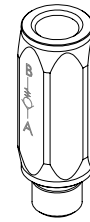
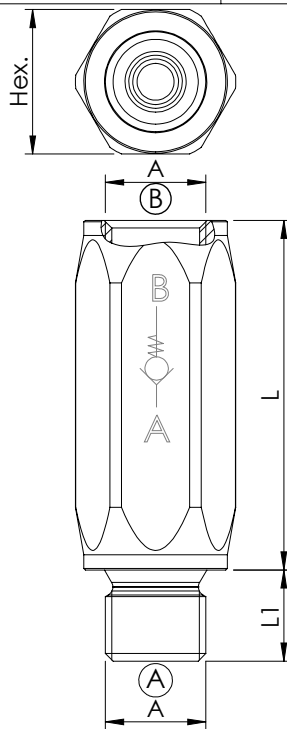

SPECIFICATIONS

Max. operating pressure:	350 bar
Rated flow:	30 - 350 l/min
Body:	Zinc plated steel

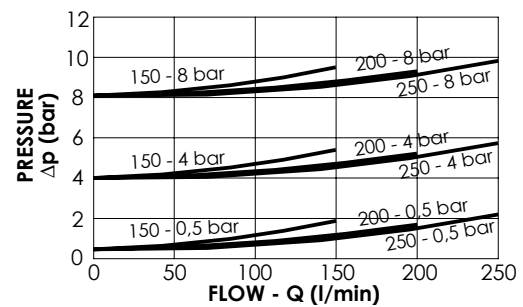
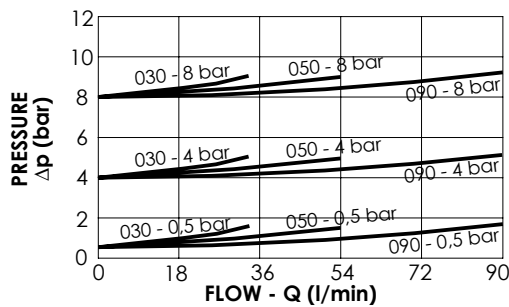

ORDERING CODES

Quick code	Description	Rated flow (l/min)	Cracking pressure (bar)	Dimension			
				A	L	L1	HEX
CD000425	CDVN-030-PSNP-MF-G14-N008	30	8	G 1/4"	46	12	19
CD000424	CDVN-030-PSNP-MF-G14-N004	30	4	G 1/4"	46	12	19
CD000423	CDVN-030-PSNP-MF-G14-N001	30	0,5	G 1/4"	46	12	19
CD000428	CDVN-050-PSNP-MF-G38-N008	50	8	G 3/8"	50	12	24
CD000427	CDVN-050-PSNP-MF-G38-N004	50	4	G 3/8"	50	12	24
CD000426	CDVN-050-PSNP-MF-G38-N001	50	0,5	G 3/8"	50	12	24
CD000136	CDVN-090-PSNP-MF-G12-N008	90	8	G 1/2"	57	14	30
CD000291	CDVN-090-PSNP-MF-G12-N004	90	4	G 1/2"	57	14	30
CD000142	CDVN-090-PSNP-MF-G12-N001	90	0,5	G 1/2"	57	14	30
CD000139	CDVN-150-PSNP-MF-G34-N008	150	8	G 3/4"	60	16	36
CD000292	CDVN-150-PSNP-MF-G34-N004	150	4	G 3/4"	60	16	36
CD000143	CDVN-150-PSNP-MF-G34-N001	150	0,5	G 3/4"	60	16	36
CD000140	CDVN-200-PSNP-MF-G10-N008	200	8	G 1"	88	18	45
CD000293	CDVN-200-PSNP-MF-G10-N004	200	4	G 1"	88	18	45
CD000144	CDVN-200-PSNP-MF-G10-N001	200	0,5	G 1"	88	18	45
CD000141	CDVN-250-PSNP-MF-G11-N008	250	8	G 1" 1/4	102	20	55
CD000294	CDVN-250-PSNP-MF-G11-N004	250	4	G 1" 1/4	102	20	55
CD000145	CDVN-250-PSNP-MF-G11-N001	250	0,5	G 1" 1/4	102	20	55

CHECK VALVE

CDVN-XXX-PSNP

SLEEVE
POPPET TYPE

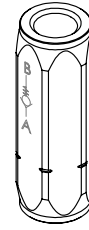
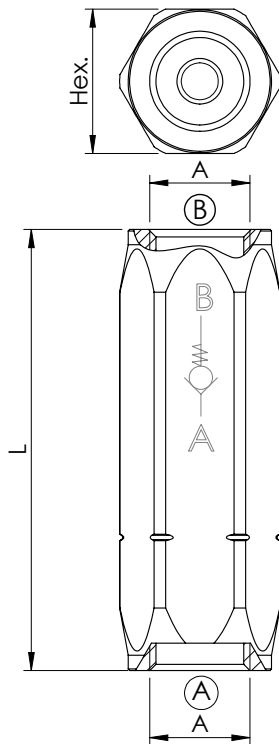

SPECIFICATIONS

Max. operating pressure:	350 bar
Rated flow:	30 - 250 l/min
Body:	Zinc plated steel

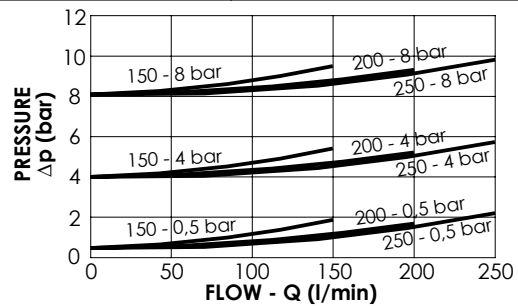
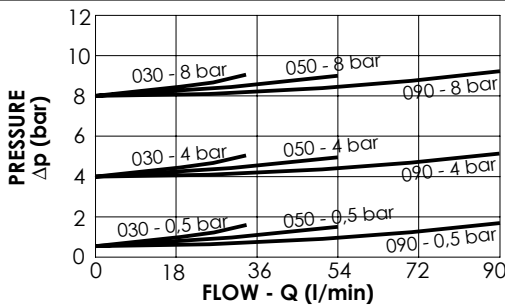

ORDERING CODES

Quick code	Description	Rated flow (l/min)	Cracking pressure (bar)	Dimension		
				A	L	HEX
CD000324	CDVN-030-PSNP-FF-G14-N008	30	8	G 1/4"	58	19
CD000312	CDVN-030-PSNP-FF-G14-N004	30	4	G 1/4"	58	19
CD000317	CDVN-030-PSNP-FF-G14-N001	30	0,5	G 1/4"	58	19
CD000323	CDVN-050-PSNP-FF-G38-N008	50	8	G 3/8"	62	24
CD000318	CDVN-050-PSNP-FF-G38-N004	50	4	G 3/8"	62	24
CD000212	CDVN-050-PSNP-FF-G38-N001	50	0,5	G 3/8"	62	24
CD000277	CDVN-090-PSNP-FF-G12-N008	90	8	G 1/2"	71	30
CD000287	CDVN-090-PSNP-FF-G12-N004	90	4	G 1/2"	71	30
CD000281	CDVN-090-PSNP-FF-G12-N001	90	0,5	G 1/2"	71	30
CD000278	CDVN-150-PSNP-FF-G34-N008	150	8	G 3/4"	83	36
CD000421	CDVN-150-PSNP-FF-G34-N006	150	6	G 3/4"	83	36
CD000288	CDVN-150-PSNP-FF-G34-N004	150	4	G 3/4"	83	36
CD000282	CDVN-150-PSNP-FF-G34-N001	150	0,5	G 3/4"	83	36
CD000279	CDVN-200-PSNP-FF-G10-N008	200	8	G 1"	106	45
CD000289	CDVN-200-PSNP-FF-G10-N004	200	4	G 1"	106	45
CD000283	CDVN-200-PSNP-FF-G10-N001	200	0,5	G 1"	106	45
CD000280	CDVN-250-PSNP-FF-G11-N008	250	8	G 1" 1/4	127	55
CD000290	CDVN-250-PSNP-FF-G11-N004	250	4	G 1" 1/4	127	55
CD000284	CDVN-250-PSNP-FF-G11-N001	250	0,5	G 1" 1/4	127	55

CHECK VALVE

CDVN-010-DSNS

INSERT TYPE
DOUBLE MOUNTING

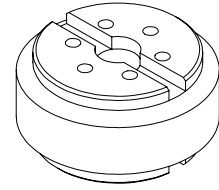
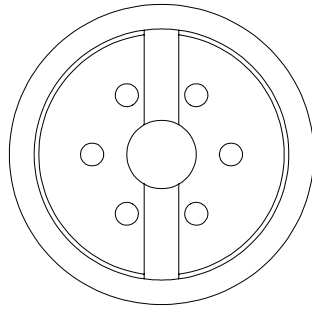
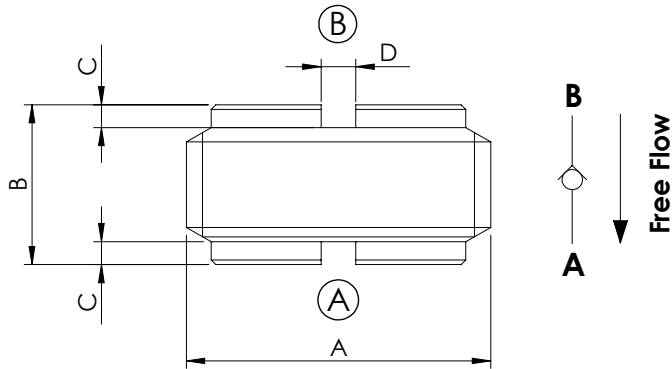

SPECIFICATIONS

Max. operating pressure:	350 bar
Rated flow:	See table
Cavity:	See table
Weight:	0,1 kg

NOTES

- Disk type
- Not leak proof
- Without spring

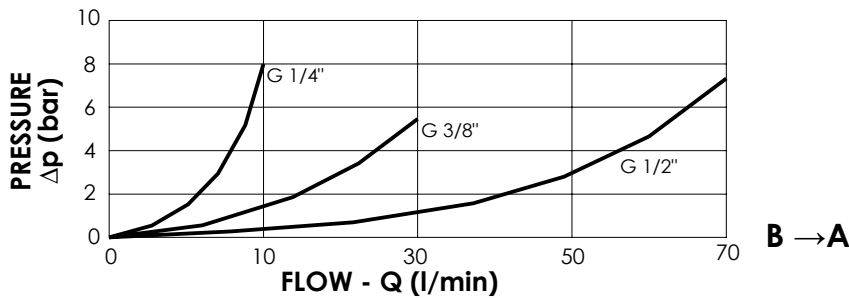

CODE	RATED FLOW
G 1/4"	10 l/min
G 3/8"	30 l/min
G 1/2"	70 l/min

ORDERING CODES

Quick code	Description	Install. torque (Nm)	Cracking pressure (bar)	Dimension			
				A	B	C	D
CD000150	CDVN-010-DSNS-00-G14-N350	5	0	G 1/4"	7	1	1,5
CD000148	CDVN-030-DSNS-00-G38-N350	10	0	G 3/8"	7,5	1	1,5
CD000151	CDVN-070-DSNS-00-G12-N350	10	0	G 1/2"	11	1,5	1,5