



ATLANTIC
Fluid Tech



OIL SOLUTIONS

PO Box 38
Strathfieldsaye, VIC, 3551
1800 OIL SOL
1800 645 765

sales@oilsolutions.com.au

www.oilsolutions.com.au

"For All Your Hydraulic Needs"

**SECTION
17**

**Diverter
Valves**

SECTION 17



DIVERTER VALVES

Hydraulic scheme	Valve description	Valve type	Rated flow (l/min)	Max. pressure (bar)	Installation	Main port size or cavity type	Page
	ESCB-025	Three ports	25	250-310	In line	G 1/4"	17.01. 010
	ESCB-050	Three ports	50	250-310	In line	G 3/8"	17.01. 020
	ESCB-090	Three ports	90	250-310	In line	G 1/2"	17.01. 030
	ELFB-025	Six ports single	25	250-310	In line	G 1/4"	17.02. 040
	ESFB-025	Six ports single and bankable	25	250-310	In line/Flanged	G 1/4"	17.03. 050
	ESFB-050	Six ports single and bankable	50	250-350	In line/Flanged	G 3/8"	17.03. 060
	ESFB-100	Six ports single and bankable	90	250-350	In line/Flanged	G 1/2"	17.03. 070
	ELFB-400	Six ports single	400	210-420	In line	G 3/4" - 1" SAE 6000	17.04. 080
	ELHB-010	Eight ports, with detent	10	210	In line	G 1/4"	17.05. 090

FLOW DIVERTERS

ESCB-025

3 WAYS FLOW DIVERTERS



**	Circuit	Transit position
40		
41		
42		
43		

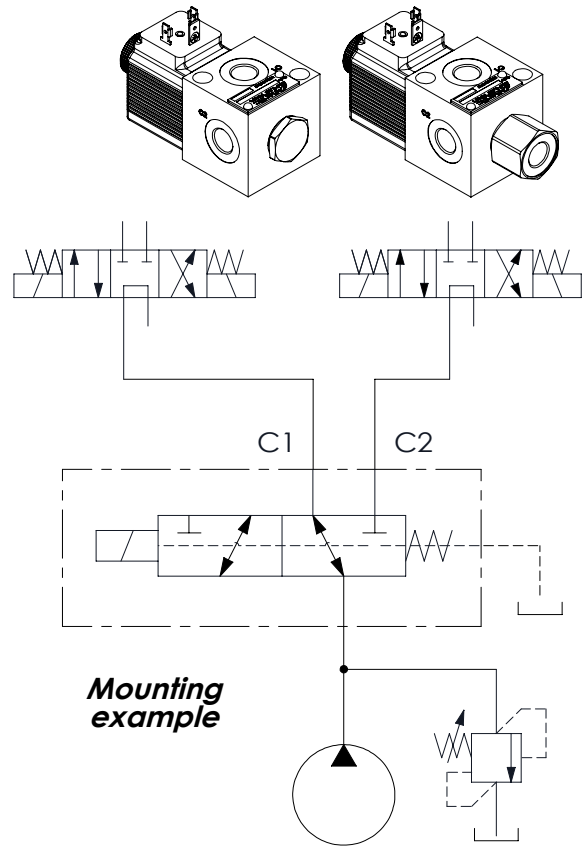

Technical data		
Rated flow	l/min	25
Operating pressure	with internal drain "N"	bar 250
	with external drain "E"	bar 310
Valve weight	Kg	0,80

OVERALL DIMENSIONS

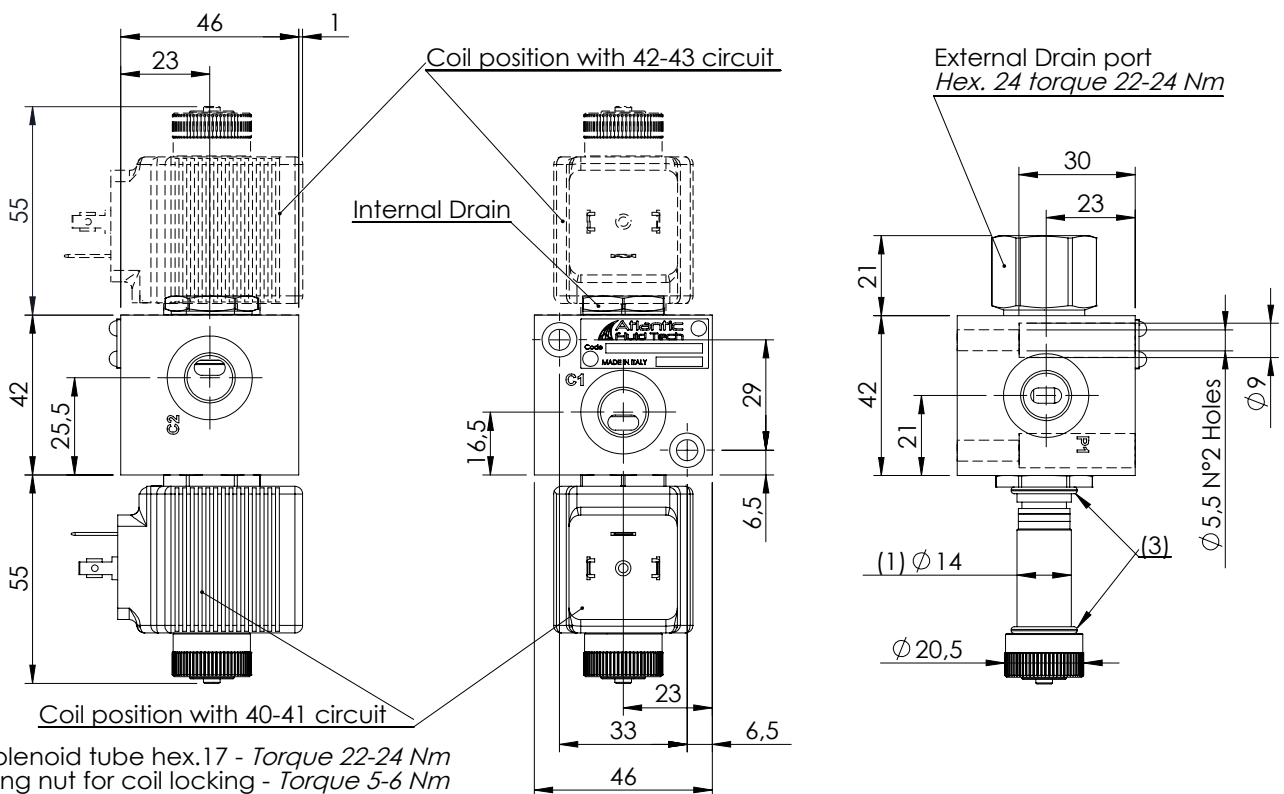

- (1) Solenoid tube hex.17 - Torque 22-24 Nm
- (2) Ring nut for coil locking - Torque 5-6 Nm
- (3) O-Ring Ø14,00x1,78

Characteristic curves

Measured with hydraulic fluid ISO-VG46 at 40° ± 5°C



Maximum performance

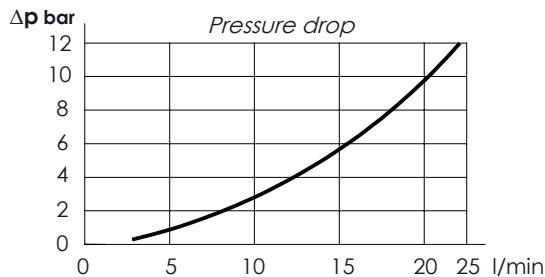
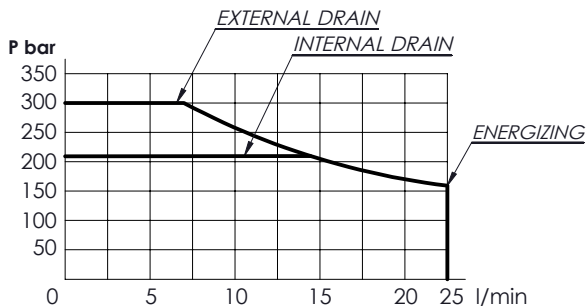

Internal leakage on C ports : MAX 15 cm³/min - Mineral oil with 32 cSt viscosity, at 40° C and 100 bar pressure

* OPERATED	Circuit
E Electric 	
N Hydraulic/pneumatic <p>(4) Hydraulic or pneumatic pilot connector: hex 30 mm - Torque 20-22 Nm With external drain Pilot Pressure Min. 5 bar With internal drain Pilot Pressure is 1/10 of the working pressure</p>	

* MANUAL OVERRIDE	
S Standard	
V Screw	
N Without manual override	

* DRAIN	Circuit
N Internal	
E External	

PORTS		
***	Main (C)	Drain (D)
G14	1/4" Gas	1/4" Gas
Other port sizes available		

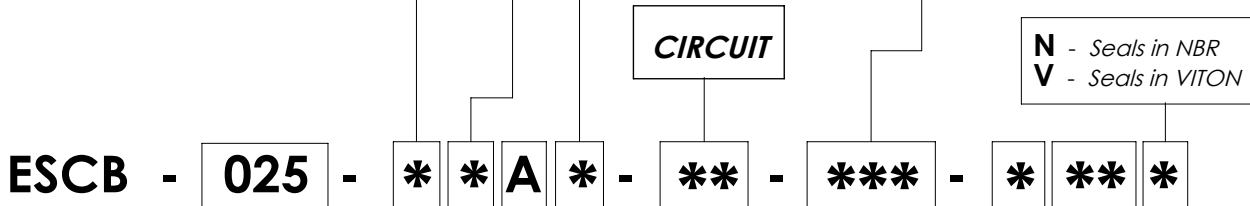

* Voltage (V)	Resistance (Ω) ± 7%	Power (W)	Current (A)
-	Without coil		
A	12 DC	5,53	26
B	24 DC	22,1	1,08
Other voltages available on request			

* COIL	Type	Protection class
-	Without coil	
HR	DIN 43650 - ISO 4400 Class H	M14 IP65
AJ	AMP JUNIOR Class H	M14 IP65
DT	DEUTSCH DT04-2P-L Class H	M14 IP69

FLOW DIVERTERS

ESCB-050

3 WAYS FLOW DIVERTERS



**	Circuit	Transit position
40		
41		
42		
43		

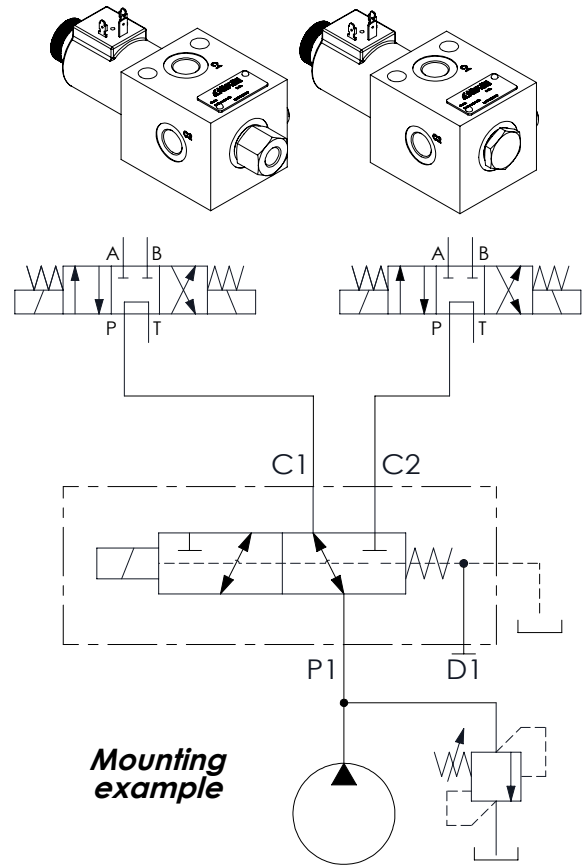

Technical data			
Rated flow		l/min	50
Operating pressure	with internal drain "N"	bar	250
	with external drain "E"	bar	310
Valve weight		Kg	2,6

OVERALL DIMENSIONS

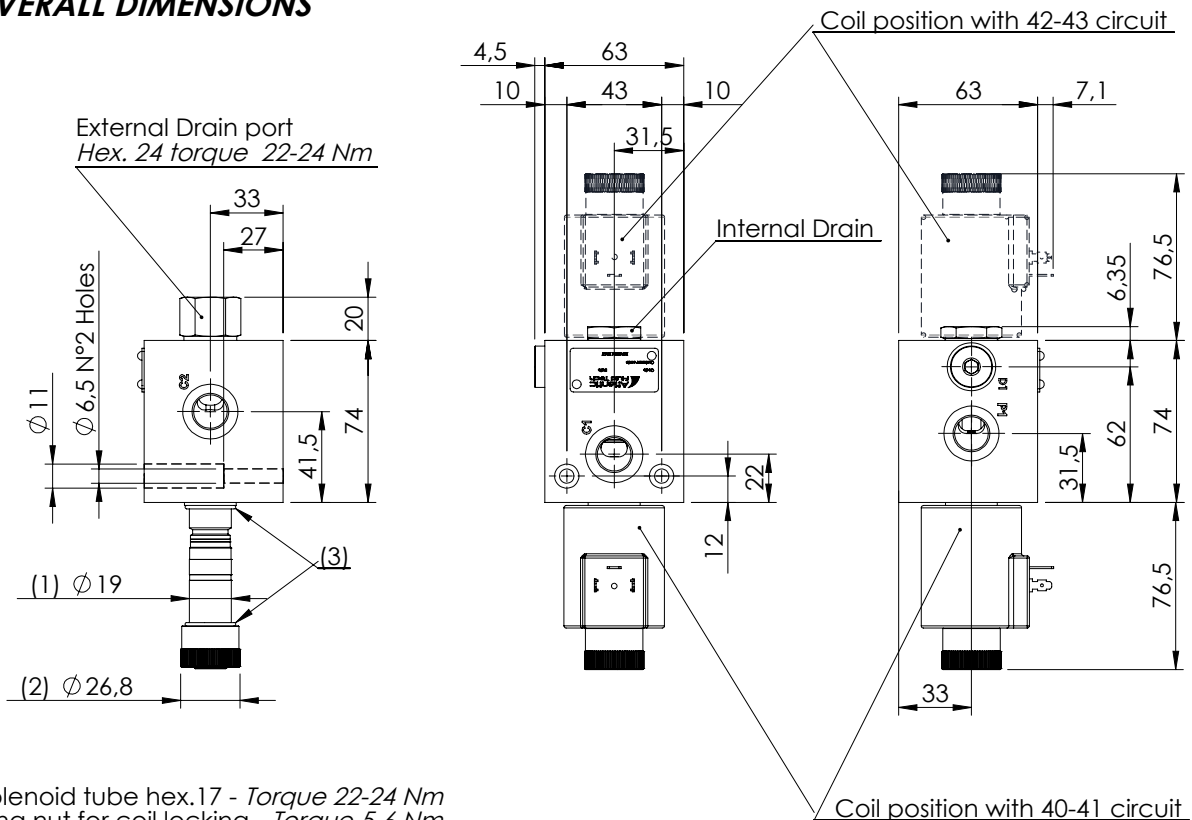

- (1) Solenoid tube hex.17 - Torque 22-24 Nm
- (2) Ring nut for coil locking - Torque 5-6 Nm
- (3) O-Ring Ø18,77 x1,78

Characteristic curves

Measured with hydraulic fluid ISO-VG46 at 40° ± 5°C

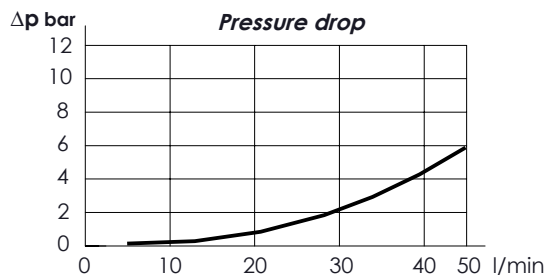
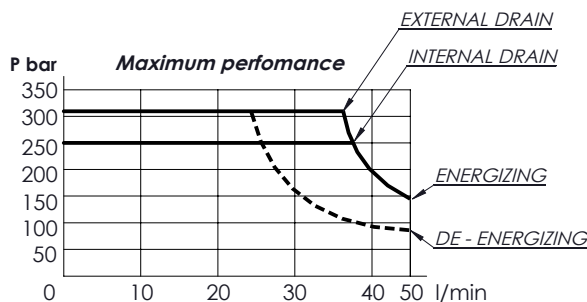

Internal leakage on C ports : MAX 25 cm³/min - Mineral oil with 32 cSt viscosity, at 40° C and 100 bar pressure

*	OPERATED	<i>Circuit</i>	*	MANUAL OVERRIDE	*	DRAIN	<i>Circuit</i>															
E	Electric 		S	Standard 	N	Internal 																
N	Hydraulic/pneumatic 		V	Screw 	E	External 																
	<p>(4) Hydraulic or pneumatic pilot connector: hex 30 mm - Torque 20-22 Nm</p> <p>With external drain Pilot Pressure Min. 5 bar</p> <p>With internal drain Pilot Pressure is 1/10 of the working pressure</p>		N	Without manual override	<table border="1"> <thead> <tr> <th colspan="3">PORTS</th> </tr> <tr> <th>***</th> <th>Main (C)</th> <th>Drain (D)</th> </tr> </thead> <tbody> <tr> <td>G38</td> <td>3/8" Gas</td> <td>1/4" Gas</td> </tr> <tr> <td></td> <td></td> <td></td> </tr> <tr> <td></td> <td></td> <td></td> </tr> </tbody> </table> <p>Other port sizes available</p>			PORTS			***	Main (C)	Drain (D)	G38	3/8" Gas	1/4" Gas						
PORTS																						
***	Main (C)	Drain (D)																				
G38	3/8" Gas	1/4" Gas																				

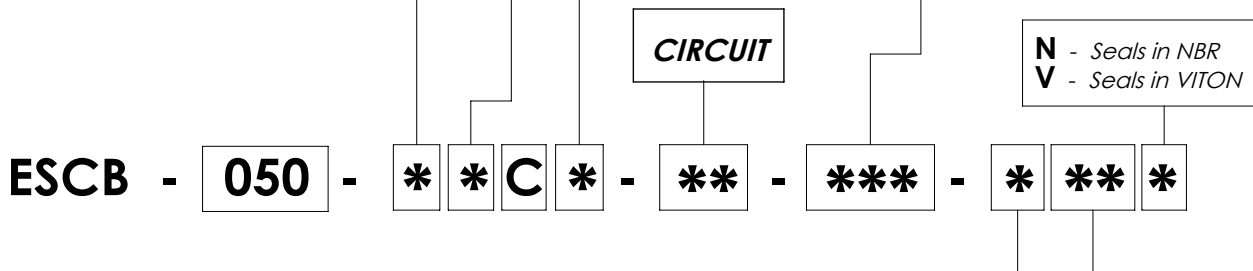

*	Voltage (V)	Resistance (Ω) ± 7%	Power (W)	Current (A)
-	<i>Without coil</i>			
A	12 DC	4,36	33	2,75
B	24 DC	17,45	33	1,37
<i>Other voltages available on request</i>				

*	COIL	Type	Protection class
-	<i>Without coil</i>		
HR	DIN 43650 - ISO 4400 Class H	M8	IP65
AJ	AMP JUNIOR Class H	M8	IP65
DT	DEUTSCH DT04-2P-L Class H	M8	IP69

**	Circuit	Transit position
40		
41		
42		
43		

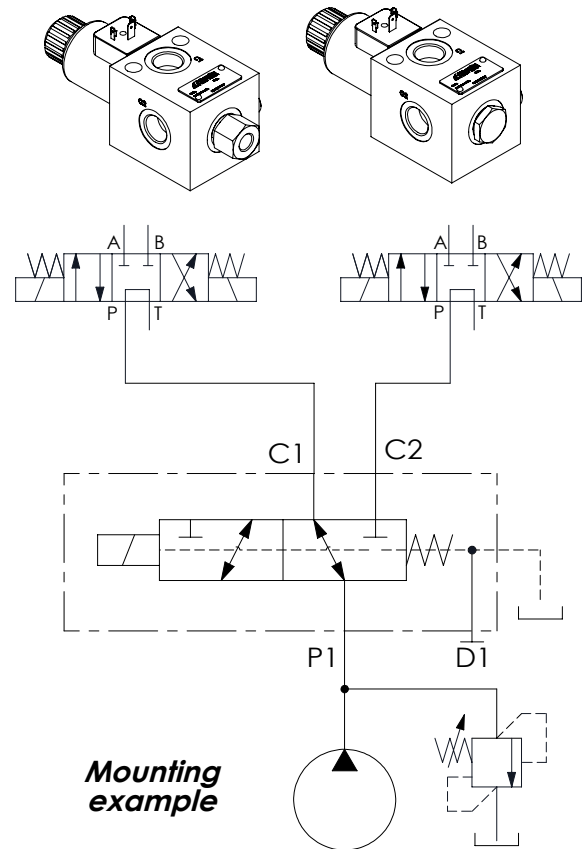

Technical data

Rated flow	l/min	90
Operating pressure	with internal drain "N"	bar 250
	with external drain "E"	bar 310
Valve weight	Kg	2,4

OVERALL DIMENSIONS

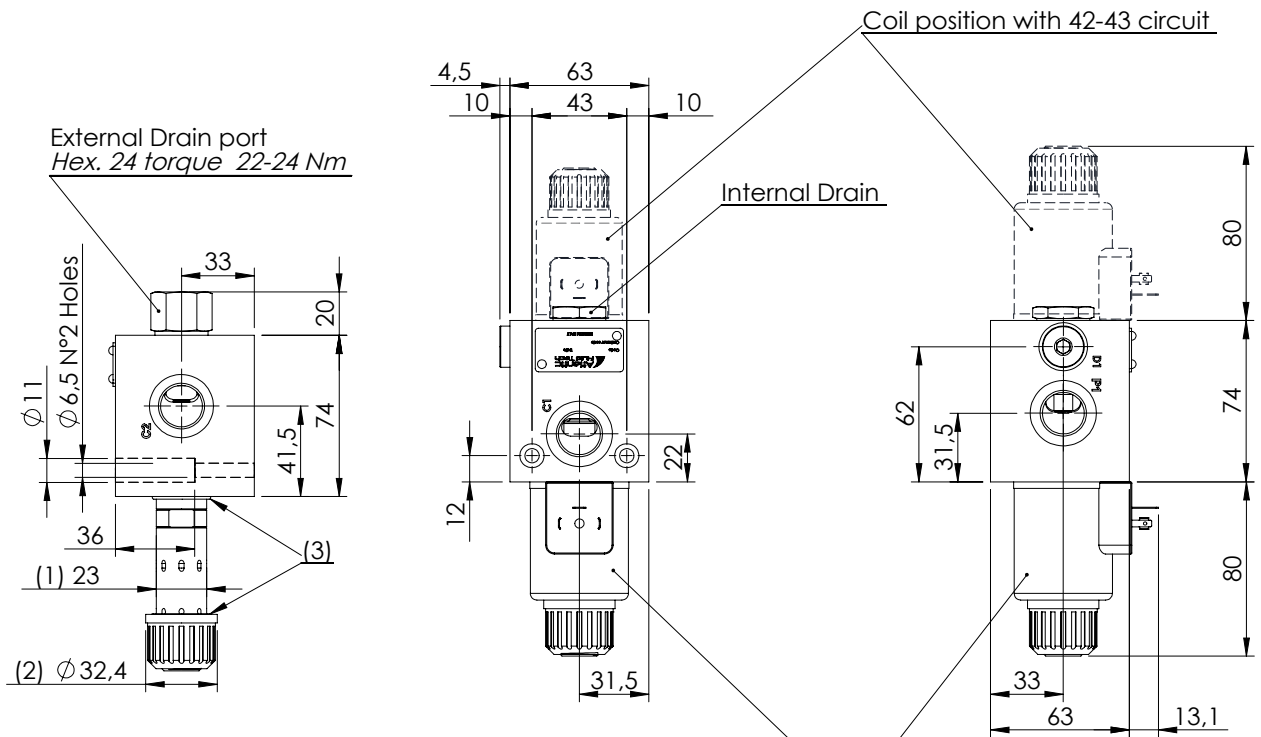

- (1) Solenoid tube hex.20 - Torque 18-22 Nm
- (2) Ring nut for coil locking - Torque 7-8 Nm
- (3) O-Ring $\varnothing 21,95 \times 1,78 - 22,22 \times 2,62$ (smaller one near manifold)

Characteristic curves

Measured with hydraulic fluid ISO-VG46 at 40° ± 5°C

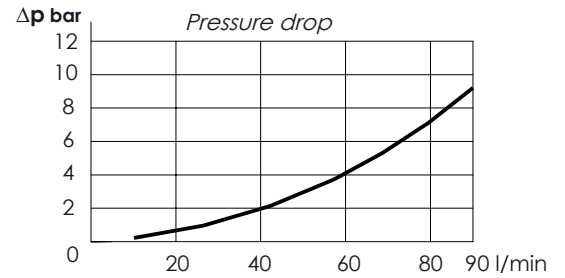
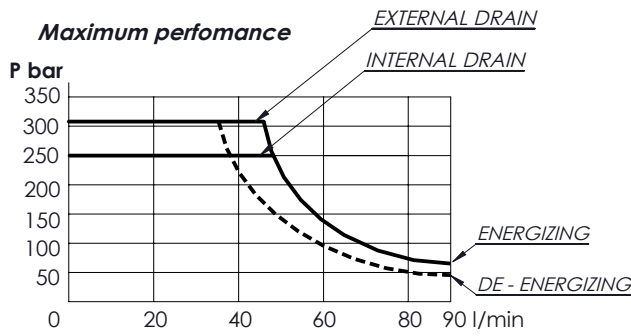

Internal leakage on C ports : MAX 25 cm³/min - Mineral oil with 32 cSt viscosity, at 40° C and 100 bar pressure

* OPERATED	Circuit	* MANUAL OVERRIDE	* DRAIN	Circuit															
E Electric 		S Standard 	N Internal 																
N Hydraulic/pneumatic 		V Screw 	E External 																
<p>(4) Hydraulic or pneumatic pilot connector: hex 30 mm - Torque 20-22 Nm</p> <p>With external drain Pilot Pressure Min. 5 bar</p> <p>With internal drain Pilot Pressure is 1/10 of the working pressure</p>		N Without manual override	<table border="1"> <thead> <tr> <th colspan="3">PORTS</th> </tr> <tr> <th>***</th> <th>Main (C)</th> <th>Drain (D)</th> </tr> </thead> <tbody> <tr> <td>G12</td> <td>1/2" Gas</td> <td>1/4" Gas</td> </tr> <tr> <td></td> <td></td> <td></td> </tr> <tr> <td></td> <td></td> <td></td> </tr> </tbody> </table> <p>Other port sizes available</p>		PORTS			***	Main (C)	Drain (D)	G12	1/2" Gas	1/4" Gas						
PORTS																			
***	Main (C)	Drain (D)																	
G12	1/2" Gas	1/4" Gas																	

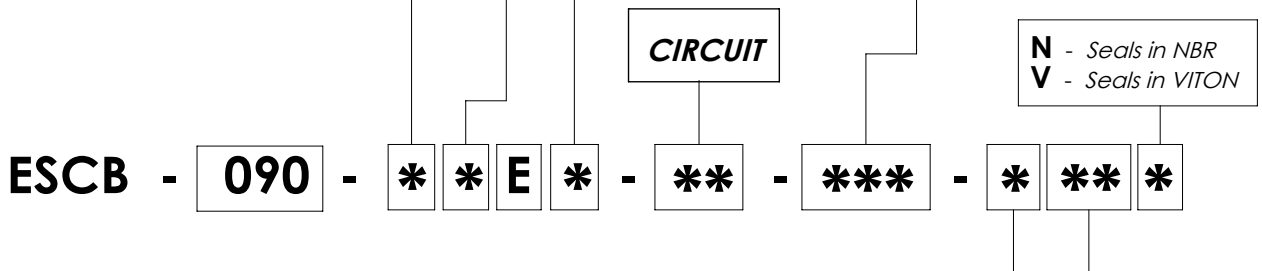

* Voltage (V)	Resistance (Ω) ± 7%	Power (W)	Current (A)
-	Without coil		
A 12 DC	3,27	44	3,67
B 24 DC	13,09	44	1,83
Other voltages available on request			

* COIL	Type	Protection class
-	Without coil	
HR DIN 43650 - ISO 4400 Class H	M11	IP65
AJ AMP JUNIOR Class H	M11	IP65
DT DEUTSCH DT04-2P-L Class H	M11	IP69

FLOW DIVERTERS

ELFB-025

**6 WAYS SINGLE IN LINE
FLOW DIVERTERS**



**	Circuit	Transit position
01		
02		
03		

*Only external drain

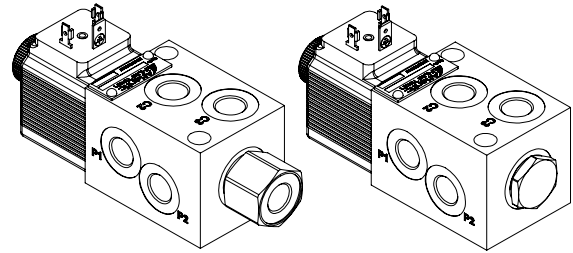

Mounting example

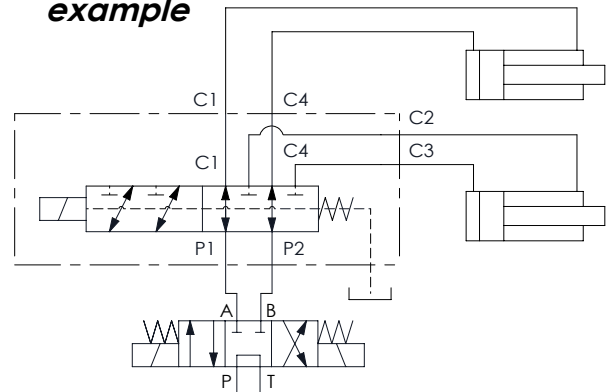

Technical data

Rated flow		l/min	25
Operating pressure	with internal drain "N"	bar	250
	with external drain "E"	bar	310
Valve weight		Kg	1,1

OVERALL DIMENSIONS

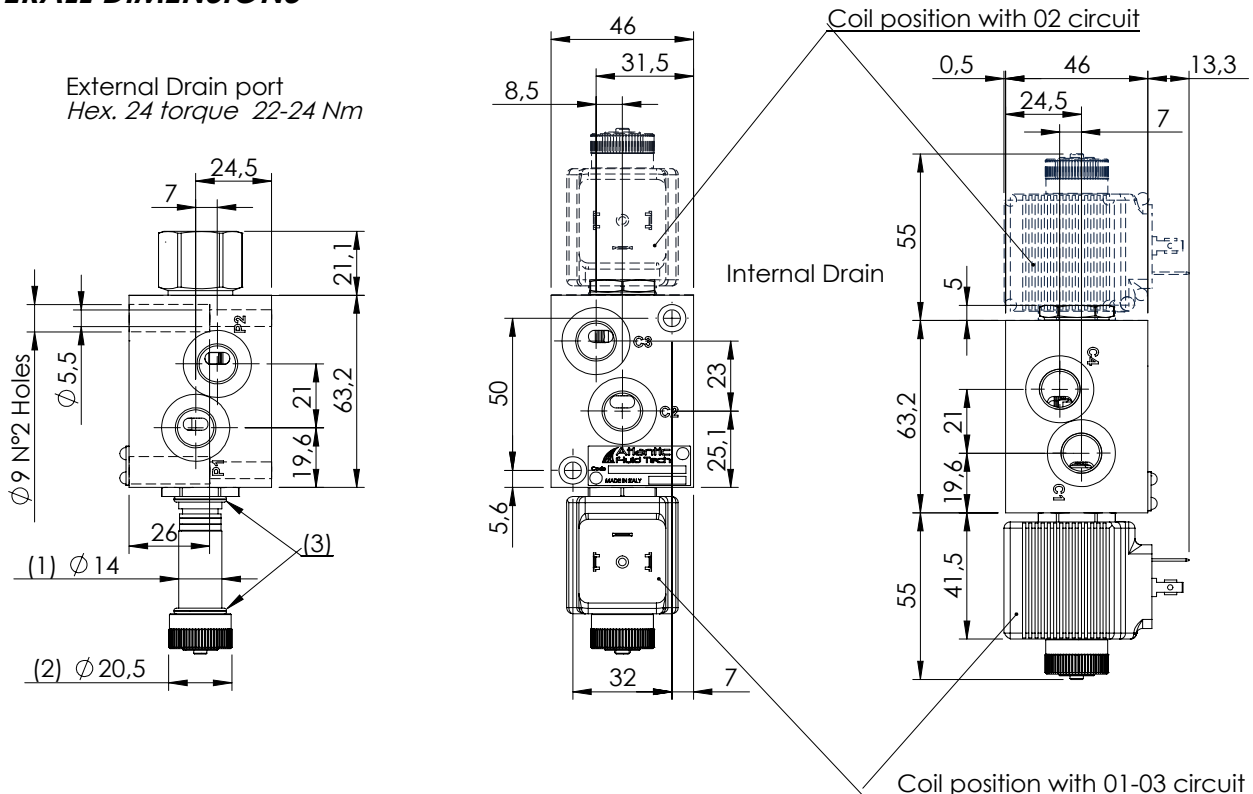





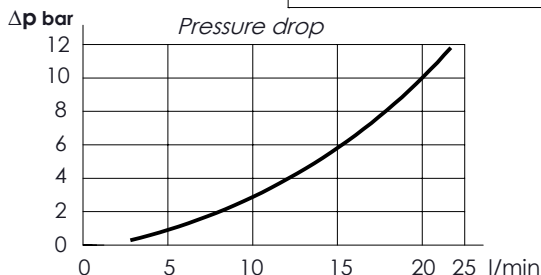
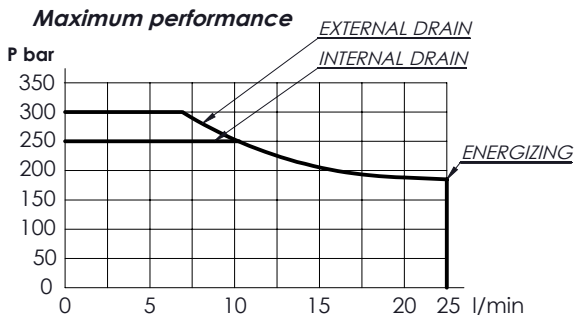

- (1) Solenoid tube hex.17 - Torque 22-24 Nm
- (2) Ring nut for coil locking - Torque 5-6 Nm
- (3) O-Ring Ø 14,00 x 1,78

Characteristic curves

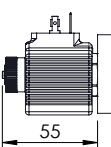
Measured with hydraulic fluid ISO-VG46 at 40° ± 5°C

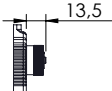

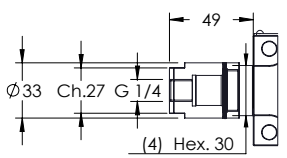
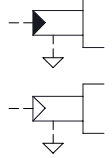
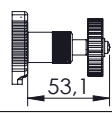

Internal leakage on C ports : MAX 15 cm³/min Mineral oil with 32 cSt viscosity, at 40° C and 100 bar pressure

*	OPERATED	<i>Circuit</i>	*	MANUAL OVERRIDE		*	DRAIN	<i>Circuit</i>															
E	Electric 		S	Standard 	13,5	N	Internal 																
N	Hydraulic/pneumatic 		V	Screw 	53,1	E	External 																
<p>(4) Hydraulic or pneumatic pilot connector: hex 30 mm - Torque 20-22 Nm</p> <p>With external drain Pilot Pressure Min. 5 bar</p> <p>With internal drain Pilot Pressure is 1/10 of the working pressure</p>			N	Without manual override		<table border="1"> <tr> <th colspan="3">PORTS</th> </tr> <tr> <td>***</td> <td>Main (C)</td> <td>Drain (D)</td> </tr> <tr> <td>G14</td> <td>1/4" Gas</td> <td>1/4" Gas</td> </tr> <tr> <td></td> <td></td> <td></td> </tr> <tr> <td colspan="3">Other port sizes available</td> </tr> </table>			PORTS			***	Main (C)	Drain (D)	G14	1/4" Gas	1/4" Gas				Other port sizes available		
PORTS																							
***	Main (C)	Drain (D)																					
G14	1/4" Gas	1/4" Gas																					
Other port sizes available																							

N - Seals in NBR
V - Seals in VITON

ELFB - 025 - * * A * - ** - * - * ** ***

*	Voltage (V)	Resistance (Ω) ± 7%	Power (W)	Current (A)
-	Without coil			
A	12 DC	5,53	26	2,17
B	24 DC	22,1	26	1,08
Other voltages available on request				

*	COIL	Type	Protection class
-	Without coil		
HR	 DIN 43650 - ISO 4400 Class H	M14	IP65
AJ	 AMP JUNIOR Class H	M14	IP65
DT	 DEUTSCH DT04-2P-L Class H	M14	IP69

FLOW DIVERTERS

ESFB-025

**6 WAYS SINGLE & BANKABLE
FLOW DIVERTERS**



**	Circuit	Transit position
01		
02		
03		

*Only external drain

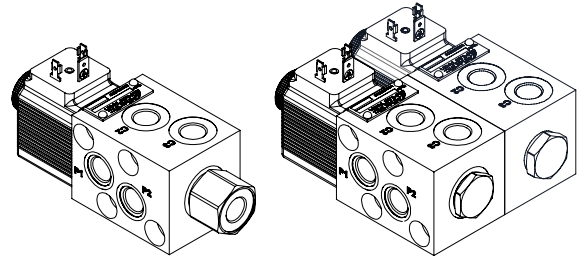

Mounting example

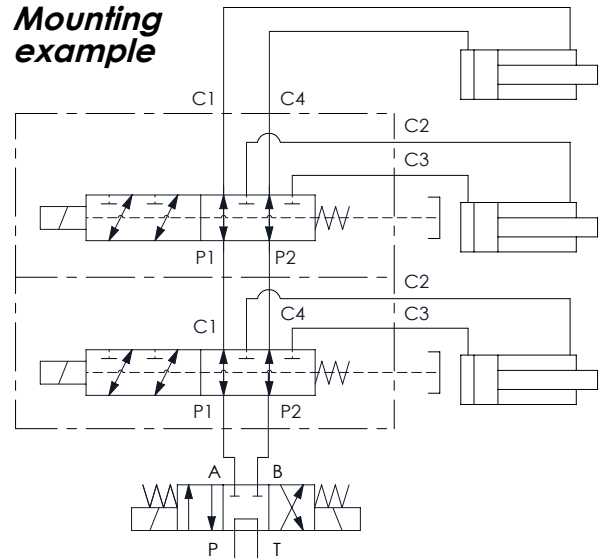

Technical data

Rated flow	l/min	25
Operating pressure	with internal drain "N"	bar 250
	with external drain "E"	bar 310
Valve weight	Kg	1

OVERALL DIMENSIONS

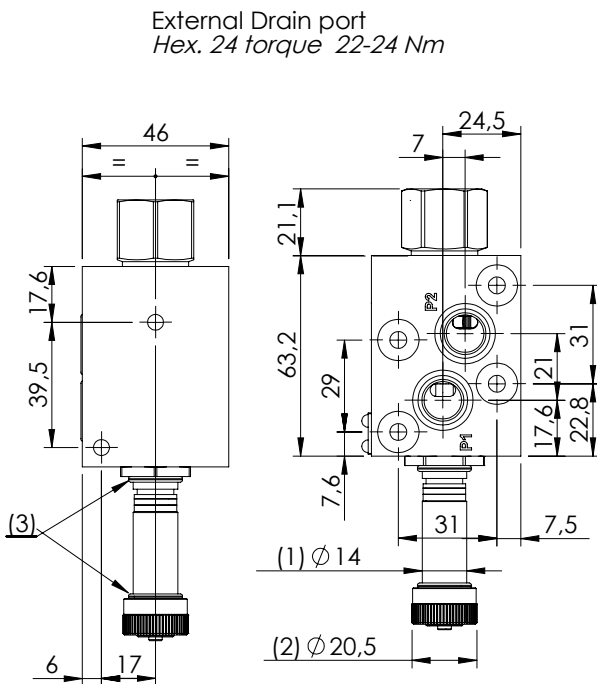

Coil position with 02 circuit

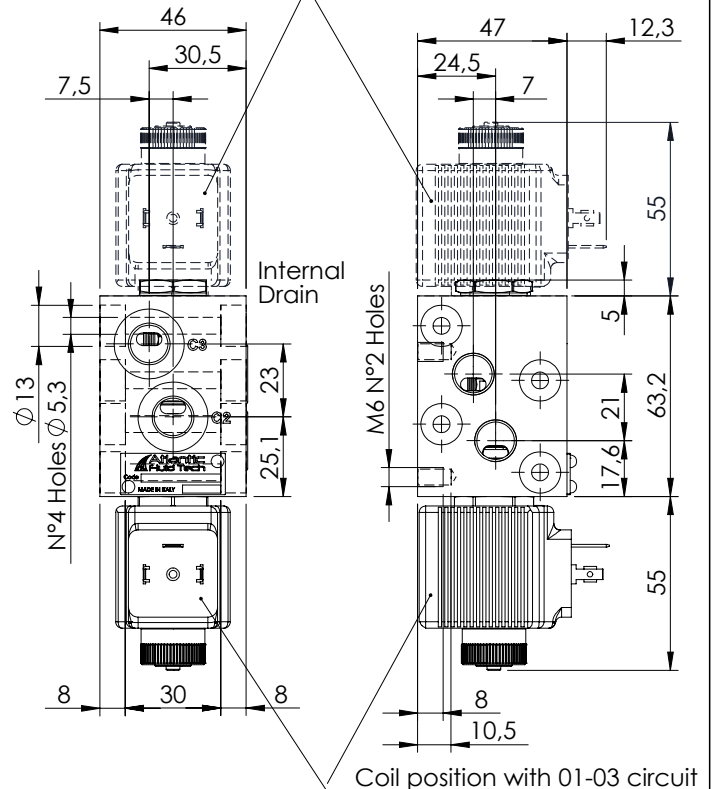





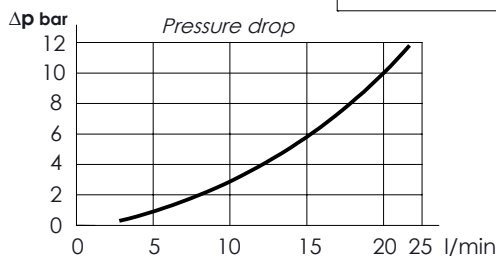
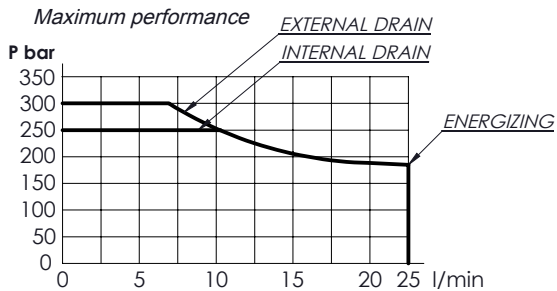

- (1) Solenoid tube hex.17 - Torque 22-24 Nm
- (2) Ring nut for coil locking - Torque 5-6 Nm
- (3) O-Ring Ø 14,00 x 1,78

Characteristic curves

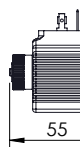
Measured with hydraulic fluid ISO-VG46 at 40° ± 5°C

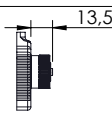

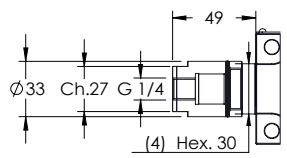
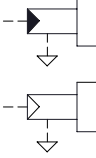
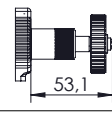
Internal leakage on C ports :
MAX 15 cm³/min
Mineral oil with 32 cSt
viscosity, at 40° C and
100 bar pressure

* OPERATED	Circuit	* MANUAL OVERRIDE	* DRAIN	Circuit
E Electric 		S Standard 	N Internal 	
N Hydraulic/pneumatic 		V Screw 	E External 	
<p>(4) Hydraulic or pneumatic pilot connector: hex 30 mm - Torque 20-22 Nm With external drain Pilot Pressure Min. 5 bar With internal drain Pilot Pressure is 1/10 of the working pressure</p>				



PORTS		
***	Main (C)	Drain (D)
G14	1/4" Gas	1/4" Gas
Other port sizes available		

CIRCUIT

N - Seals in NBR
V - Seals in VITON

ESFB - 025 - * * A * - ** - * - * ** * ****

* Voltage (V)	Resistance (Ω) ± 7%	Power (W)	Current (A)
-	Without coil		
A 12 DC	5,53	26	2,16
B 24 DC	22,1	26	1,08
Other voltages available on request			

* COIL	Type	Protection class
-	Without coil	
HR 	DIN 43650 - ISO 4400 Class H	M14 IP65
AJ 	AMP JUNIOR Class H	M14 IP65
DT 	DEUTSCH DT04-2P-L Class H	M14 IP69

TYPE OF MOUNTING

* Port number	Screw Tie rods	Installation torque
-	-	-
08	M5x92	5-6 Nm
10	M5x138	5-6 Nm
12	M5x184	5-6 Nm
14	-	-

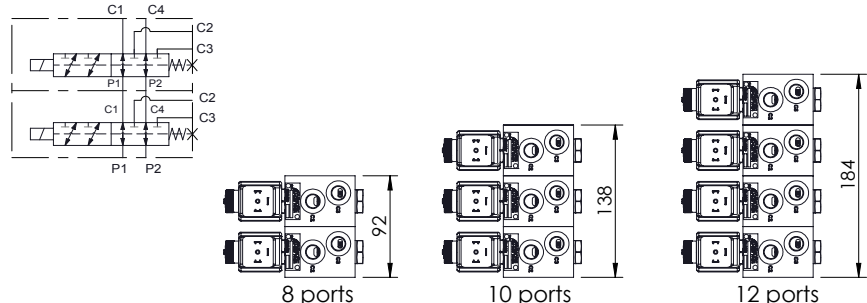

FLOW DIVERTERS

ESFB-050

**6 WAYS SINGLE & BANKABLE
FLOW DIVERTERS**



**	Circuit	Transit position
01		
02		
03		

*Only external drain

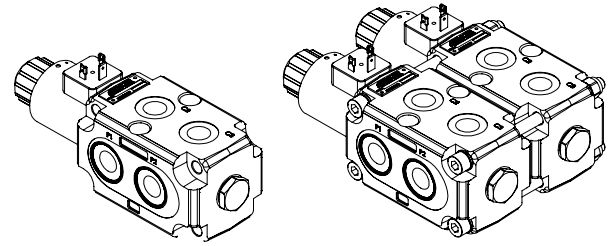

Mounting example

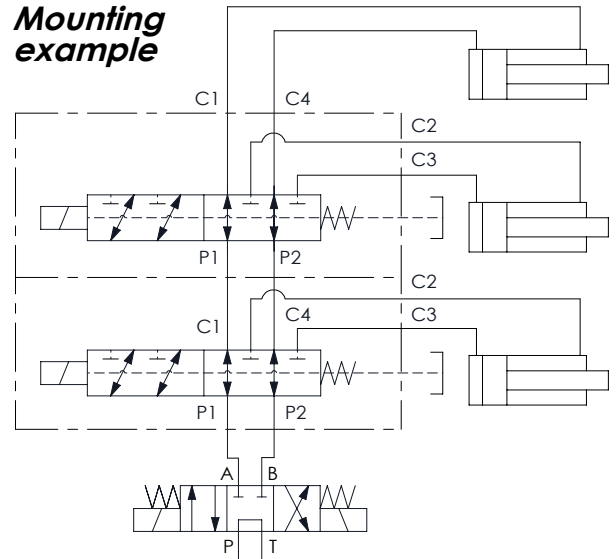

Technical data			
Rated flow	l/min		50
Operating pressure	with internal drain "N"	bar	250
	with external drain "E"	bar	350
	on port D	bar	210
Valve weight	Kg		3,8

OVERALL DIMENSIONS

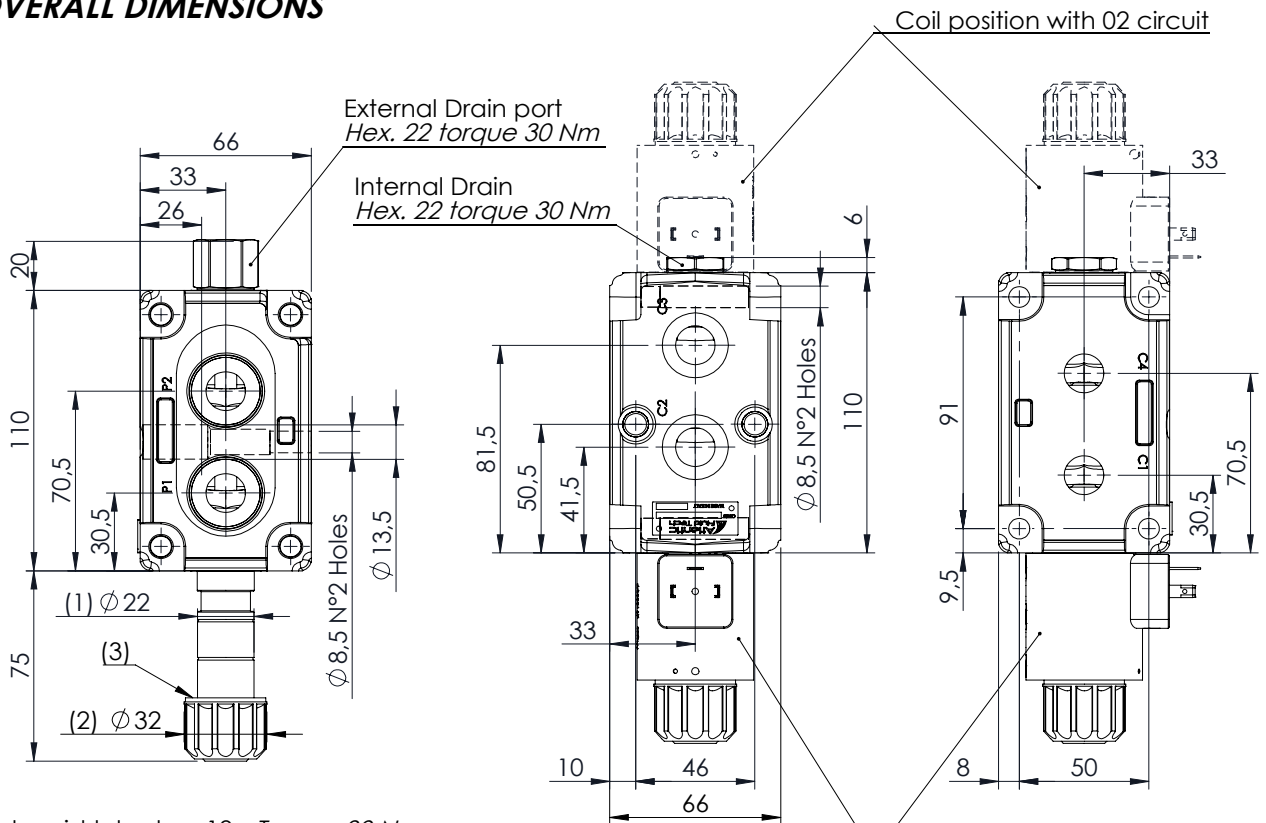

- (1) Solenoid tube hex.19 - Torque 30 Nm
- (2) Ring nut for coil locking - Torque 5-6 Nm
- (3) O-Ring Ø 21,5 x 2

Characteristic curves

Measured with hydraulic fluid ISO-VG46 at 40° ± 5°C

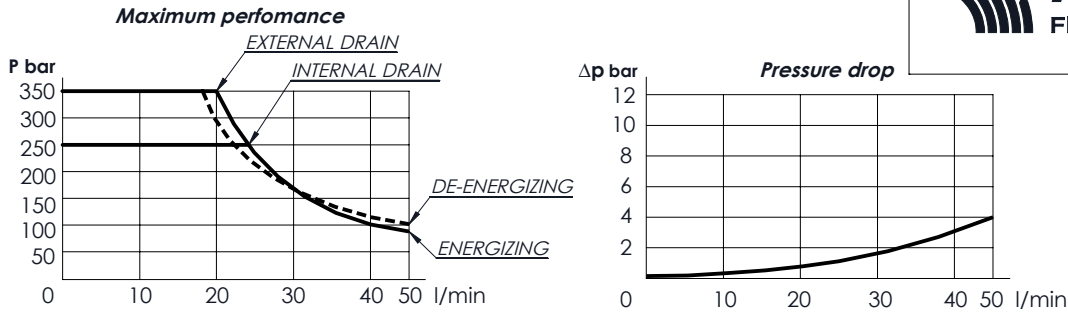

Internal leakage on C ports :
MAX 25 cm³/min
Mineral oil with 32 cSt
viscosity, at 40° C and
100 bar pressure

* OPERATED	Circuit
E Electric 	
N Hydraulic/pneumatic 	

(4) Hydraulic or pneumatic pilot connector:
hex 30 mm - Torque 20-22 Nm
With external drain Pilot Pressure Min. 5 bar
With internal drain Pilot Pressure is 1/10 of the working pressure

* MANUAL OVERRIDE	
S Standard	
V Screw	
N Without manual override	

* DRAIN	Circuit
N Internal	
E External	

*** Main (C)	Drain (D)
PORTS	
G38 3/8" Gas	1/4" Gas
J38 3/8" JIS	1/4" JIS
S08 3/4-16 UNF	7/16-20 UNF

Other port sizes available

N - Seals in NBR
V - Seals in VITON

ESFB - 050 - * * D * - ** - * - * ** * ****

* Voltage (V)	Resistance (Ω) ± 7%	Power (W)	Current (A)
-	Without coil		
A 12 DC	4,41	32,7	2,72
B 24 DC	18,6	31	1,29

Other voltages available on request

* COIL	Type	Protection class
-	Without coil	
HR	DIN 43650 - ISO 4400 Class H	M12 IP65
AJ	AMP JUNIOR Class H	M12 IP65
DT	DEUTSCH DT04-2P-L Class H	M12 IP69

TYPE OF MOUNTING

* Port number	Screw Tie rods	Installation torque
-	6	-
08	8 M8x125	15-17 Nm
10	10 M8x190	15-17 Nm
12	12 M8x255	15-17 Nm
14	14 M8x320	15-17 Nm

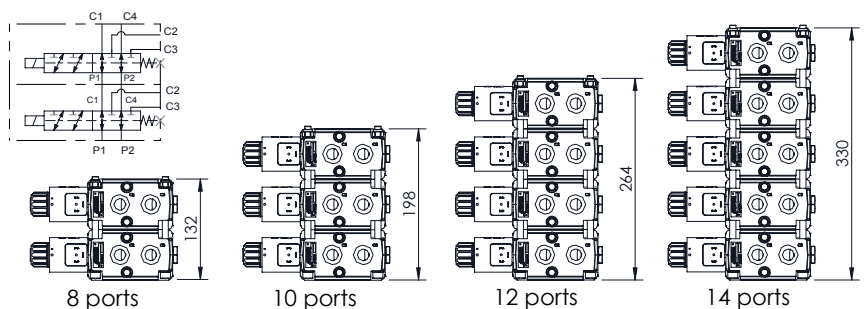

FLOW DIVERTERS

ESFB-100

**6 WAYS SINGLE & BANKABLE
FLOW DIVERTERS**



**	Circuit	Transit position
01		
02		
03		

*Only external drain

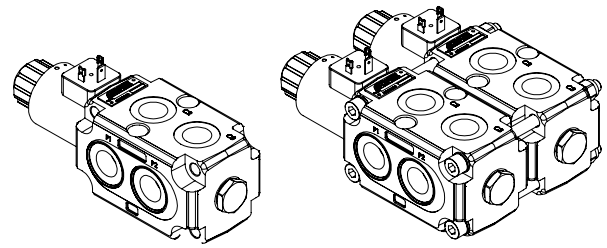

Mounting example

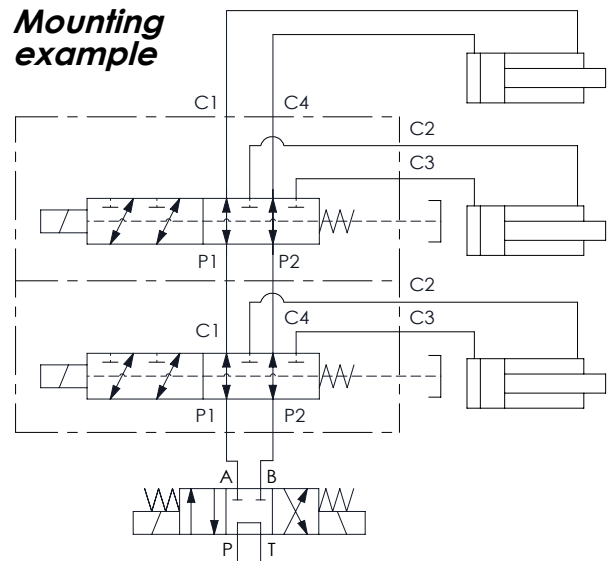

Technical data

Rated flow	l/min	100
Operating pressure	with internal drain "N"	bar 250
	with external drain "E"	bar 350
	on port D	bar 210
Valve weight	Kg	3,8

OVERALL DIMENSIONS

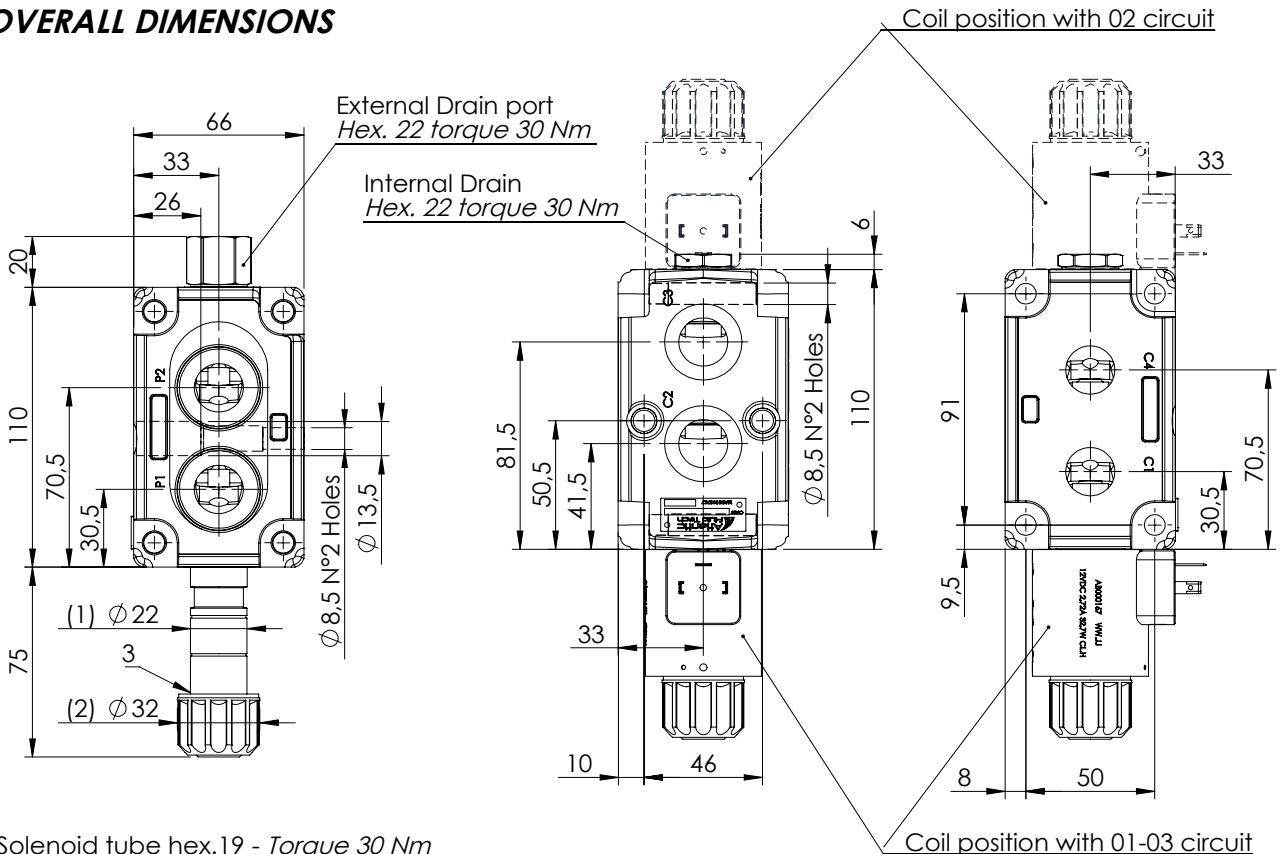

- (1) Solenoid tube hex.19 - Torque 30 Nm
- (2) Ring nut for coil locking - Torque 5-6 Nm
- (3) O-Ring Ø 21,5 x 2

Characteristic curves

Measured with hydraulic fluid ISO-VG46 at 40° ± 5°C

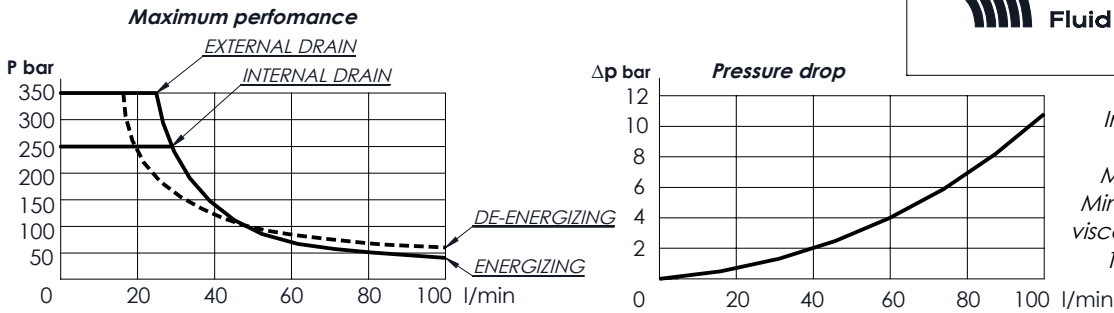

Internal leakage on C ports :
MAX 25 cm³/min
Mineral oil with 32 cSt
viscosity, at 40° C and
100 bar pressure

* OPERATED	Circuit
E Electric 	
N Hydraulic/pneumatic 	

(4) Hydraulic or pneumatic pilot connector: hex 30 mm - Torque 20-22 Nm
With external drain Pilot Pressure Min. 5 bar
With internal drain Pilot Pressure is 1/10 of the working pressure

* MANUAL OVERRIDE	Circuit
S Standard 	
V Screw 	
N Without manual override	

* DRAIN	Circuit
N Internal	
E External	

PORTS		
***	Main (C)	Drain (D)
G12	1/2" Gas	1/4" Gas
J12	1/2" JIS	1/4" JIS
S10	7/8-14 UNF	7/16-20 UNF
Other port sizes available		

N - Seals in NBR
V - Seals in VITON

CIRCUIT

ESFB - 100 - * * D * - ** - * - * ** * ****

* Voltage (V)	Resistance (Ω) ± 7%	Power (W)	Current (A)
-	Without coil		
A 12 DC	4,41	32,7	2,72
B 24 DC	18,6	31	1,29
Other voltages available on request			

* COIL	Type	Protection class
-	Without coil	
HR	DIN 43650 - ISO 4400 Class H	M12 IP65
AJ	AMP JUNIOR Class H	M12 IP65
DT	DEUTSCH DT04-2P-L Class H	M12 IP69

TYPE OF MOUNTING

* Port number	Screw Tie rods	Installation torque
-	-	-
08	M8x125	15-17 Nm
10	M8x190	15-17 Nm
12	M8x255	15-17 Nm
14	M8x320	15-17 Nm

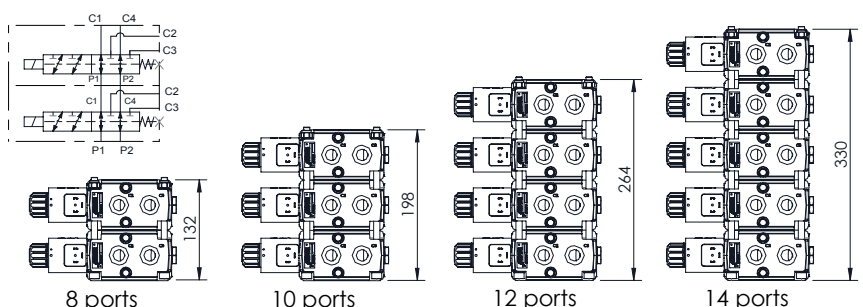

FLOW DIVERTERS

ELFB-400

**6 WAYS SINGLE IN LINE
FLOW DIVERTERS**

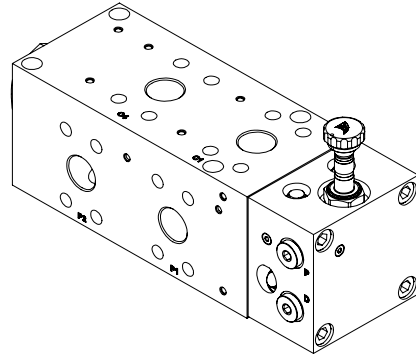
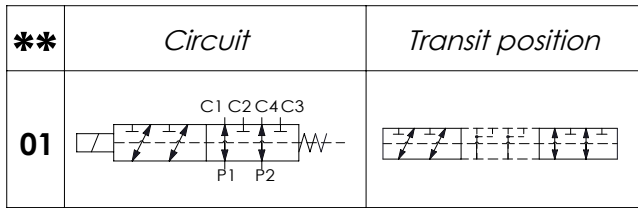

Technical data			
Rated flow		l/min	400
Operating pressure	with internal drain "N"	bar	210
	with external drain "E"	bar	420
Minimum pilot pressure		bar	20
Valve weight		Kg	17,2
Standard Ports		1" SAE 6000	

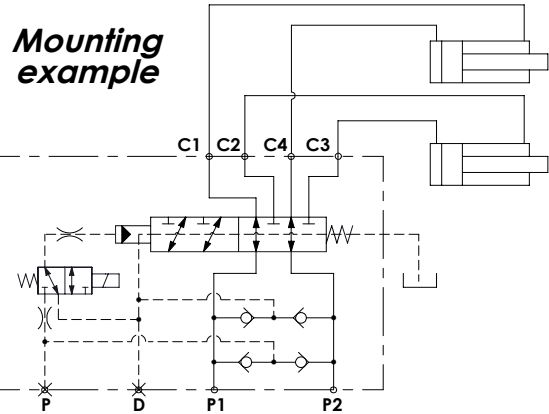

OVERALL DIMENSIONS

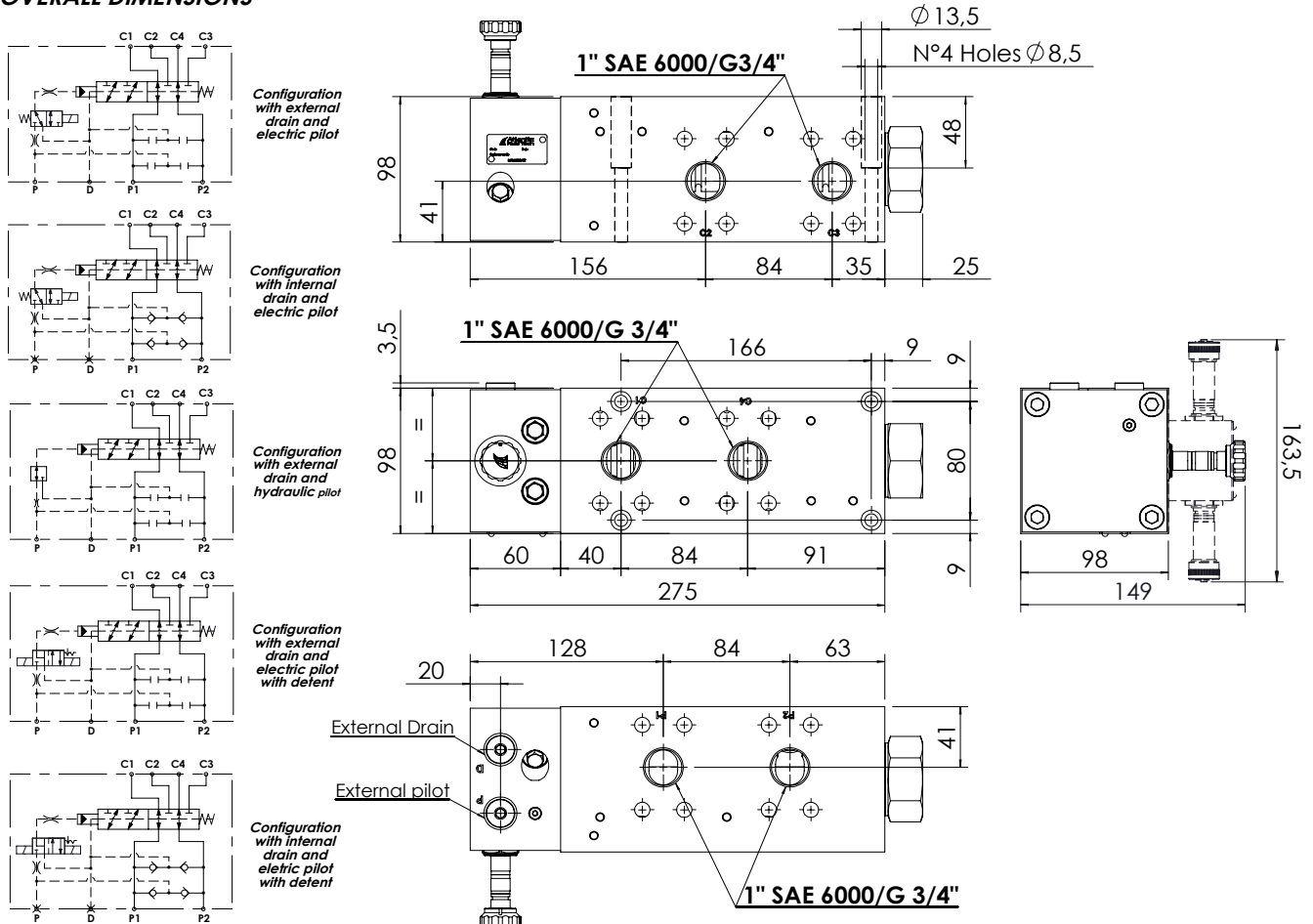

Characteristic curves

With pressure and flow in P1 or P2 and C4 and C1 without pressure



Maximum performance

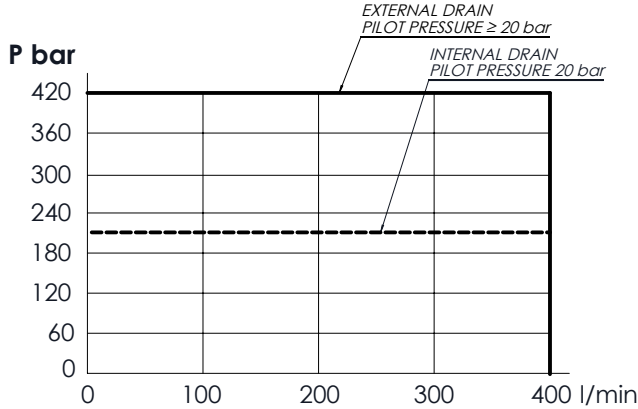

Δp bar

Pressure drop

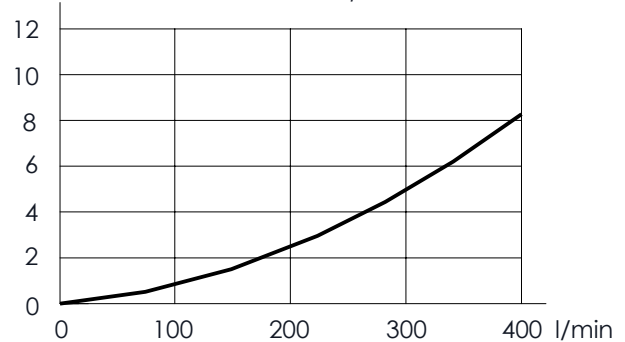

* OPERATED	Circuit
H Hydraulic 	
E Electric 	
D Electric with detent 	

Max. pilot pressure with external drain: 250 bar

* DRAIN	Circuit
N Internal	
E External	

* COIL	Type	Protection class
-	Without coil	
HR	DIN 43650 - ISO 4400 Class H	M7 IP65
AJ	AMP JUNIOR Class H	M7 IP65
DT	DEUTSCH DT04-2P-L Class H	M7 IP69

PORTS		
***	Main (C)	Drain (D) Pilot (P)
S10 G34	1" SAE 6000 G3/4"	1/4" Gas

Special port sizes available

CIRCUIT

V - Seals in VITON

ELFB - 400 - * S F * - 01 - * - * ** ***

* Voltage (V)	Resistance (Ω) $\pm 7\%$	Power (W)	Current (A)
-	Without coil		
A 12 DC	7,2	20	1,67
B 24 DC	28,7	20	0,84

Special voltages available on request

KIT	Type	Ordering code
HP	Hydraulic pilot	RG100032
EP	Electrical pilot	CE000824
ID	Internal drain	RG100033
ED	External drain	RG100034

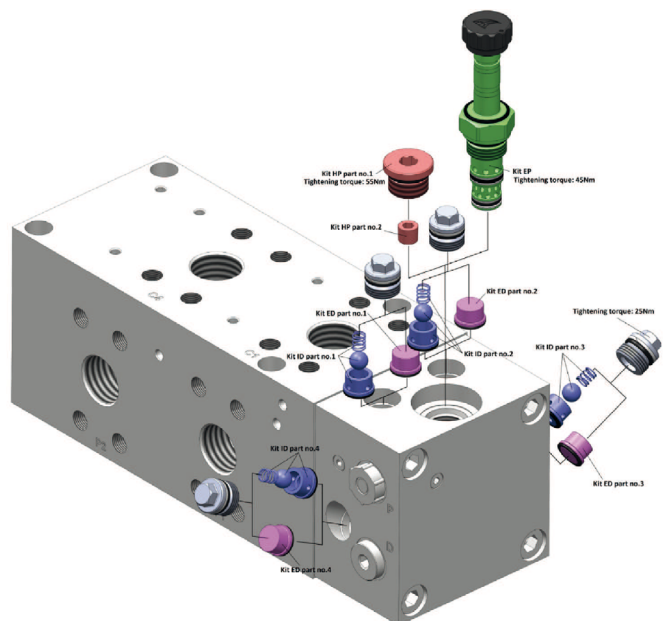

EXCAVATORS VALVE

ELHB-010-DSGN

8 WAYS WITH DETENT

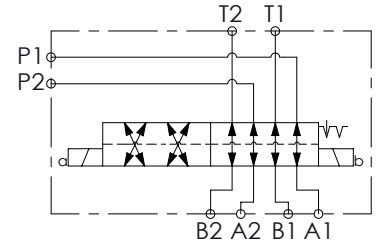
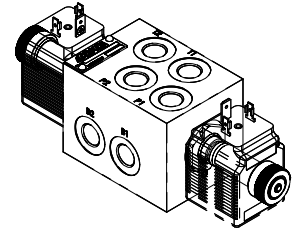
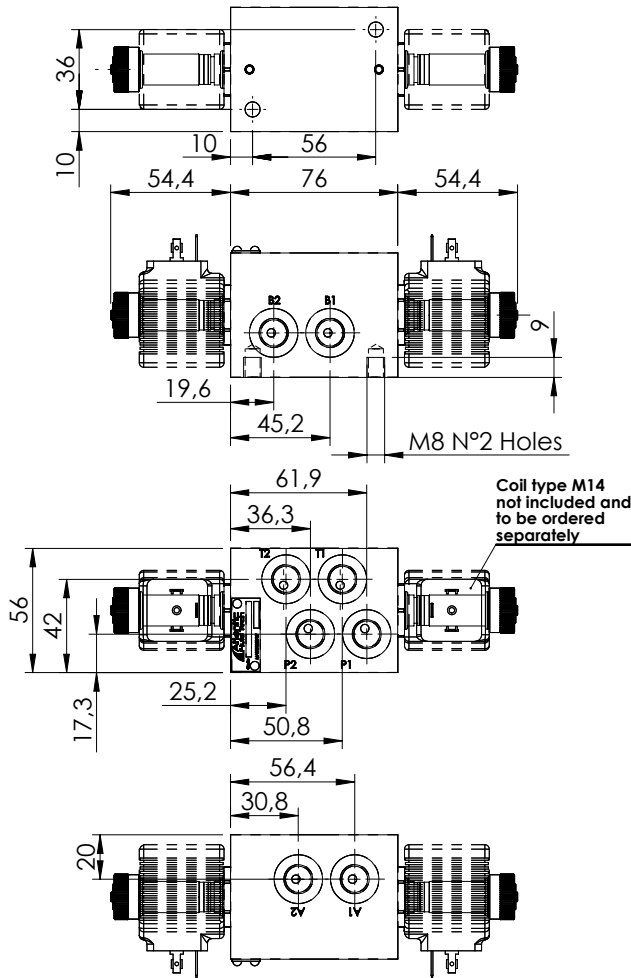

SPECIFICATIONS

Max. operating pressure:	210 bar
Rated flow:	10 l/min
Body:	Cast Iron
Weight:	1,82 kg
Coil type:	M14 type

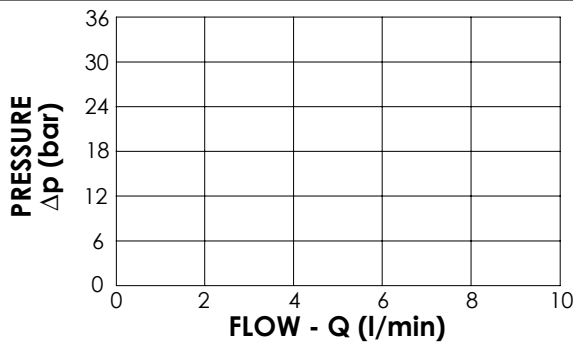

NOTES

See the chapter 18.00.000 for coil.

ORDERING CODES

Quick code	Description	Ports size	
ES000390	ELHB-010-DSGN-39-G14-N	G 1/4"	