



**ATLANTIC**  
Fluid Tech



OIL SOLUTIONS

**PO Box 38**  
**Strathfieldsaye, VIC, 3551**  
**1800 OIL SOL**  
**1800 645 765**

**[sales@oilsolutions.com.au](mailto:sales@oilsolutions.com.au)**

**[www.oilsolutions.com.au](http://www.oilsolutions.com.au)**

**"For All Your Hydraulic Needs"**

**SECTION**  
**5**

**Pilot**  
**Operated**  
**Check Valves**

## SECTION 5



## PILOT OPERATED CHECK VALVES

Hydraulic scheme	Valve description	Valve type	Rated flow (l/min)	Max. pressure (bar)	Installation	Main port size or cavity type	Page
	CDPN-030-PSGR	Poppet type	30	350	Cartridge	SAE-08-3C	5.01.010
	CDPN-060-PSGR	Poppet type	60	350	Cartridge	SAE-10-3C	5.01.020
	CDPN-060-PSGR	Poppet type	60	350	Cartridge	VP000161 (F-11A)	5.01.030
	CDPN-120-PSGR	Poppet type	120	350	Cartridge	VP000165 (F-2A)	5.01.040
	CDPN-030-PANR	Poppet type	30	350	Cartridge	VP000314	5.02.050
	CDPN-030-PSNE	Poppet type, separate pilot piston	30	350	Cartridge	VP000028	5.02.060
	CDPN-050-PSNN	Poppet type, separate pilot piston	50	350	Cartridge	VP000193	5.02.070
	CDPN-060-PSNN	Poppet type, separate pilot piston	60	350	Cartridge	VP000038	5.02.080
	MCSN-020-SLAC	Single acting, poppet type	20	350	In line	G 1/4"	5.03.090
	MCSN-030-TLNS	Single acting, poppet type	30	350	In line	G 3/8"	5.03.100
	MCSN-030-TANS	Single acting, poppet type	30	350	Flanged	G 3/8"	5.03.110
	MCSN-060-TLNS	Single acting, poppet type	60	350	In line	G 1/2"	5.03.120
	MCSN-060-TANS	Single acting, poppet type	60	350	Flanged	G 1/2"	5.03.130
	MCSN-100-TLNS	Single acting, poppet type	100	350	In line	G 3/4"	5.03.140
	MCSN-020-TLLC	Single acting, manual shut off, left version	20	210	In line	G 3/8"	5.04.150
	MCSN-020-TLRC	Single acting, manual shut off, right version	20	210	In line	G 3/8"	5.04.160
	MCDN-020-SLAS	Double acting, poppet type	20	350	In line	G 1/4"	5.05.170
	MCDN-020-SLAS	Double acting, poppet type, steel body	20	350	In line	G 3/8"	5.05.180
	MCDN-020-SLGS	Double acting, poppet type, with banjo	20	350	In line	G 3/8"	5.05.190
	MCDN-030-TLNS	Double acting, poppet type	30	350	In line	G 3/8"	5.05.200
	MCDN-030-ZBNS	Double acting, poppet type	30	350	Flanged	G 3/8"	5.05.210
	MCDN-030-TBNS	Double acting, poppet type	30	350	Flanged	G 1/4"	5.05.220
	MCDN-030-SBNS	Double acting, poppet type, steel body	30	350	Flanged	G 3/8"	5.05.230
	MCDN-060-TLNS	Double acting, poppet type	60	350	In line	G 1/2"	5.05.240
	MCDN-060-TBNS	Double acting, poppet type	60	350	Flanged	G 1/2"	5.05.250
	MCDN-100-LLNR	Double acting, poppet type	100	350	In line	G 3/4"	5.05.260

PILOTED CHECK VALVE

**CDPN-030-PSGR**

INTEGRAL PILOT  
PISTON

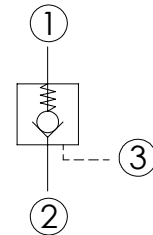
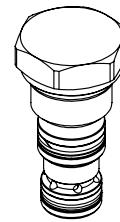
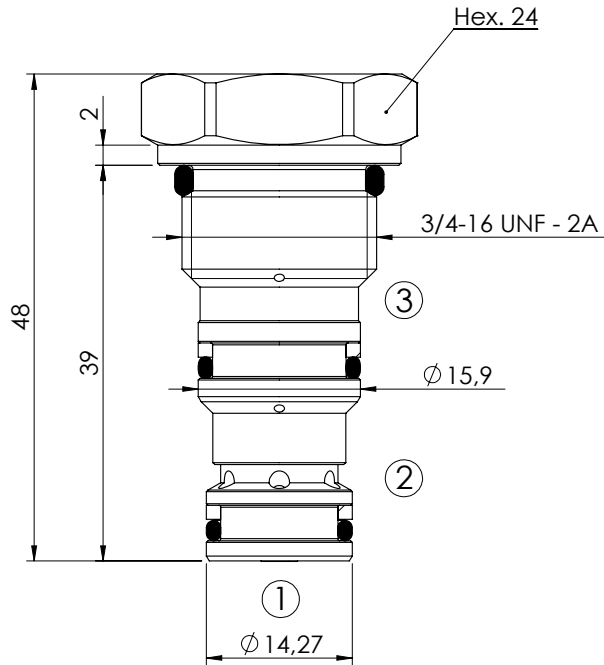

**SPECIFICATIONS**

Max. operating pressure:	350 bar
Rated flow:	30 l/min
Cavity:	SAE-08-3C
Weight:	0,09 kg
Pilot ratio:	3:1
<b>NOTES</b>	
Installation torque:	40 - 45 Nm
Seal kit:	RA700086

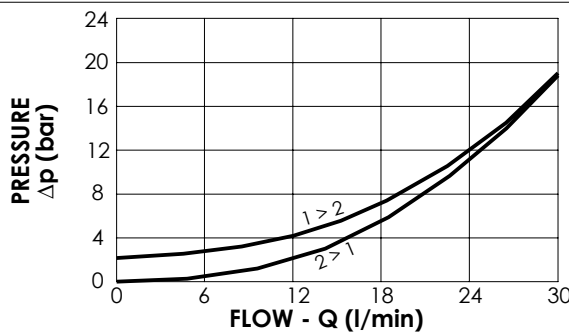

**ORDERING CODES**

Quick code	Description	Cracking pressure (bar)	O-Ring on pilot piston
CD000027	CDPN-030-PSGR-03-S08-N002	2	YES
CD000061	CDPN-030-PSGM-03-S08-N002	2	NO

PILOTED CHECK VALVE

**CDPN-060-PSGR**

INTEGRAL PILOT  
PISTON

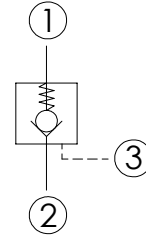
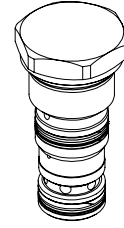
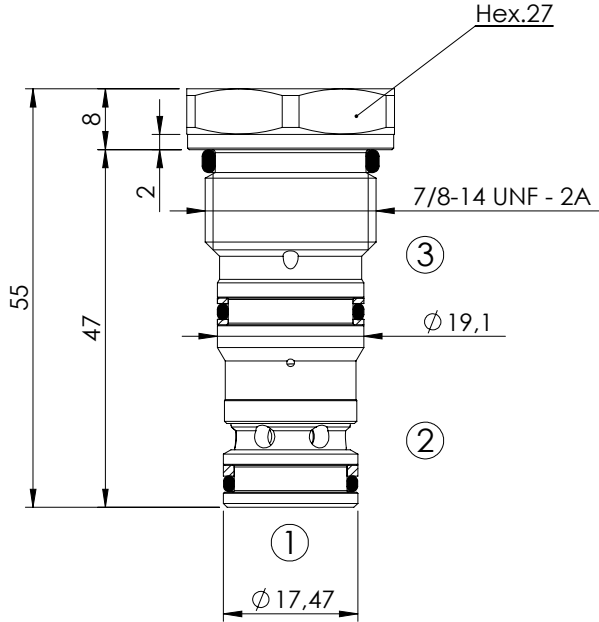

**SPECIFICATIONS**

Max. operating pressure:	350 bar
Rated flow:	60 l/min
Cavity:	SAE-10-3C
Weight:	0,12 kg
Pilot ratio:	3,2 : 1
<b>NOTES</b>	
Installation torque:	55 - 62 Nm
Seal kit:	RB700087

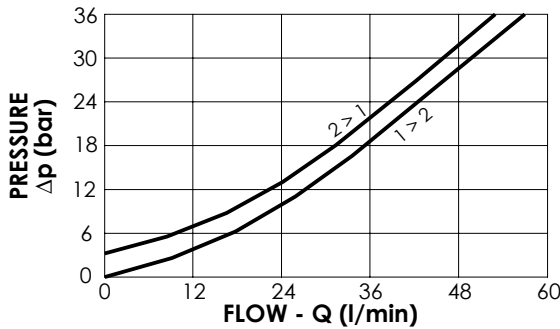

**ORDERING CODES**

Quick code	Description	Cracking pressure (bar)	O-Ring on pilot piston	
CD000109	CDPN-060-PSGR-03-S10-N002	2	YES	
CD000113	CDPN-060-PSGM-03-S10-N002	2	NO	
CD000170	CDPN-060-PSGR-03-S10-N005	5	YES	
CD000171	CDPN-060-PSGM-03-S10-N005	5	NO	

PILOTED CHECK VALVE

**CDPN-060-PSGR**

**INTEGRAL PILOT PISTON**

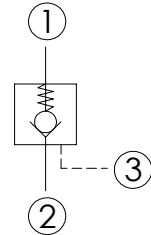
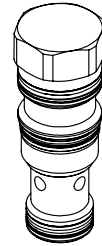
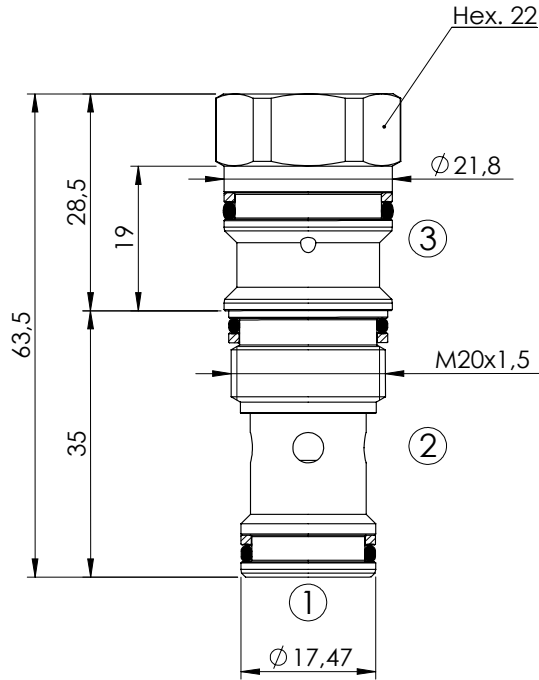

**SPECIFICATIONS**

Max. operating pressure:	350 bar
Rated flow:	60 l/min
Cavity:	VP000161 (SUN T-11A)
Weight:	0,12 kg
Pilot ratio:	3,2 : 1

**NOTES**

Installation torque:	40 - 50 Nm
Seal kit:	RC700161

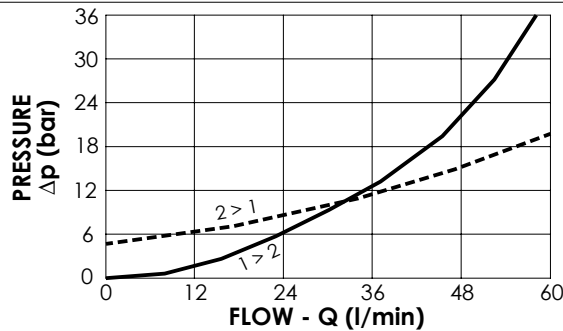

**ORDERING CODES**

Quick code	Description	Cracking pressure (bar)	O-Ring on pilot piston
CD000226	CDPN-060-PSGR-03-161-N002	2	YES
CD000227	CDPN-060-PSGM-03-161-N002	2	NO
CD000224	CDPN-060-PSGR-03-161-N005	5	YES
CD000225	CDPN-060-PSGM-03-161-N005	5	NO
CD000229	CDPN-060-PSGR-03-161-N007	7	YES

PILOTED CHECK VALVE

**CDPN-120-PSGR**

INTEGRAL PILOT  
PISTON

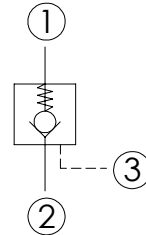
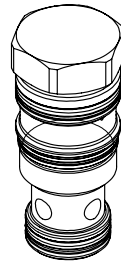
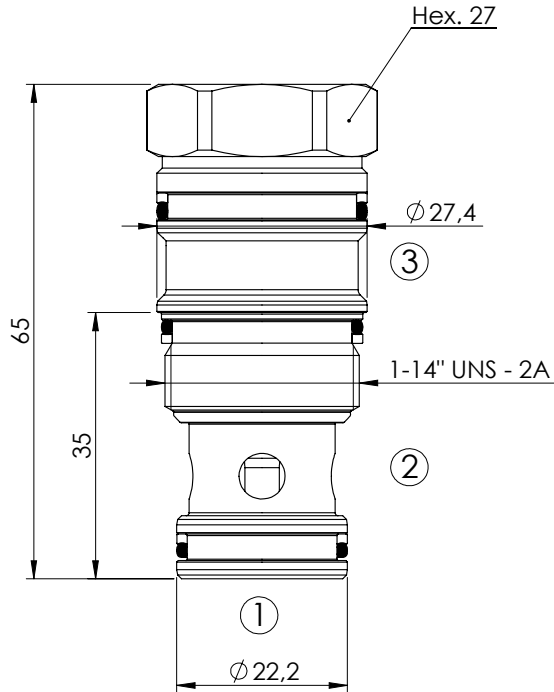

**SPECIFICATIONS**

Max. operating pressure:	350 bar
Rated flow:	120 l/min
Cavity:	VP000165 (SUN T-2A)
Weight:	0,2 kg
Pilot ratio:	3,5 : 1

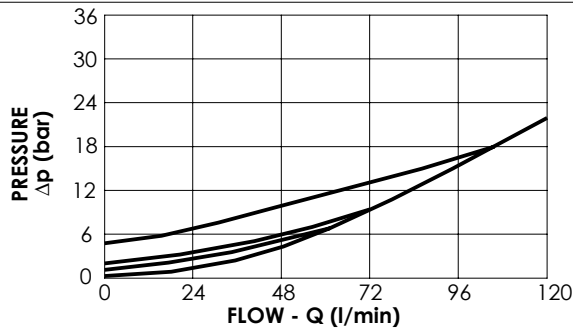

**NOTES**

Installation torque:	60 - 65 Nm
Seal kit:	RC700165

**ORDERING CODES**

Quick code	Description	Cracking pressure (bar)	O-Ring on pilot piston
CD000546	CDPN-120-PSGR-03-165-N000	0,3	YES
CD000504	CDPN-120-PSGR-03-165-N002	2	YES
CD000549	CDPN-120-PSGM-03-165-N002	2	NO
CD000536	CDPN-120-PSGM-03-165-N003	3	NO
CD000547	CDPN-120-PSGR-03-165-N005	5	YES

PILOTED CHECK VALVE

**CDPN-030-PANR**

INTEGRAL PILOT  
PISTON

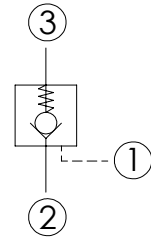
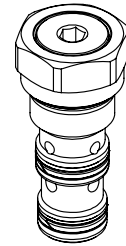
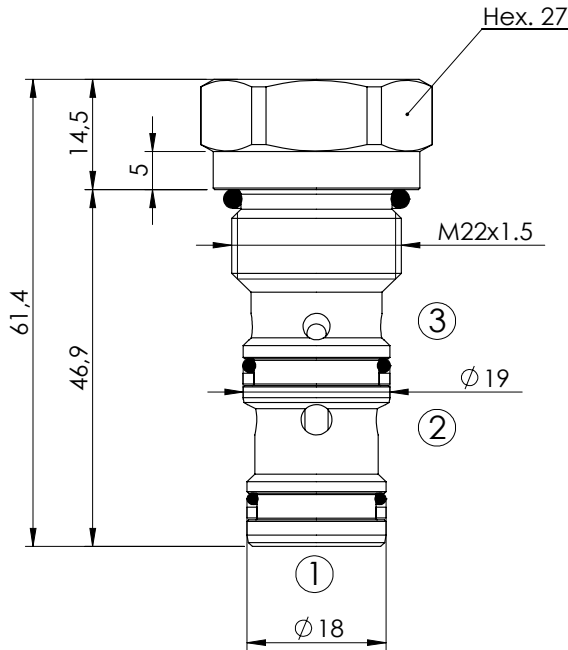

**SPECIFICATIONS**

Max. operating pressure:	350 bar
Rated flow:	30 l/min
Cavity:	VP000314
Weight:	0,1 kg
Pilot ratio:	4 : 1

**NOTES**

Installation torque:	55 - 62 Nm
Seal kit:	RC700314

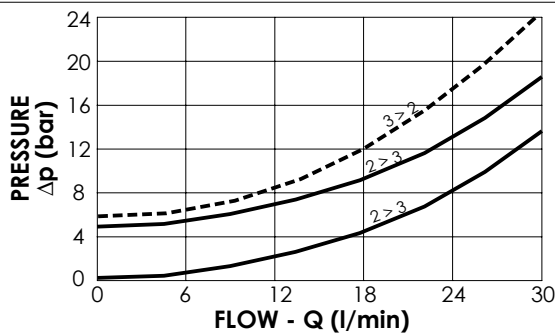

**ORDERING CODES**

Quick code	Description	Cracking pressure (bar)	O-Ring on pilot piston
CD000186	CDPN-030-PANR-04-314-N005	5	YES
CD000235	CDPN-030-PANM-04-314-N001	1	NO

PILOT OPERATED CHECK VALVE

**CDPN-030-PSNE**

SEPARATE PILOT  
PISTON

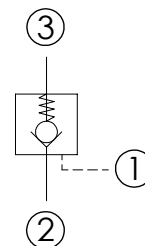
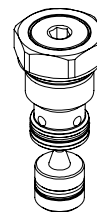
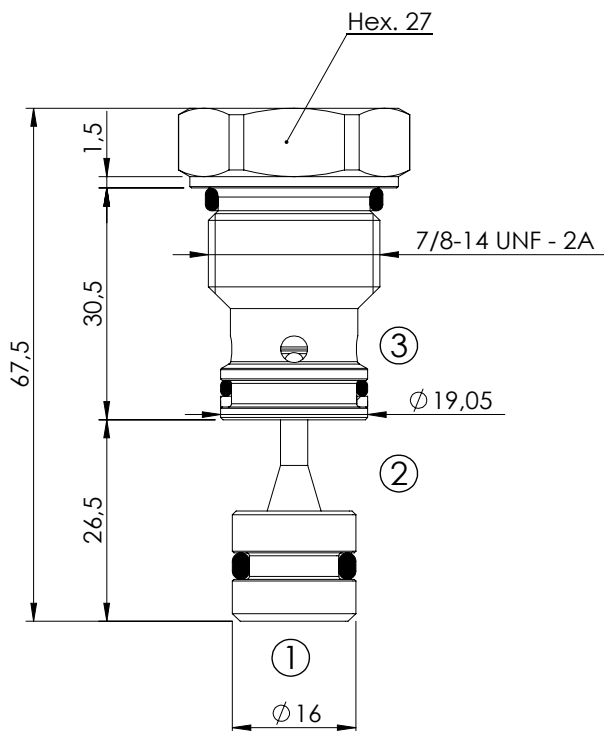

**SPECIFICATIONS**

Max. operating pressure:	350 bar
Rated flow:	30 l/min
Cavity:	VP000028
Weight:	0,13 kg
Pilot ratio:	7:1

**NOTES**

Installation torque: 80 - 90 Nm

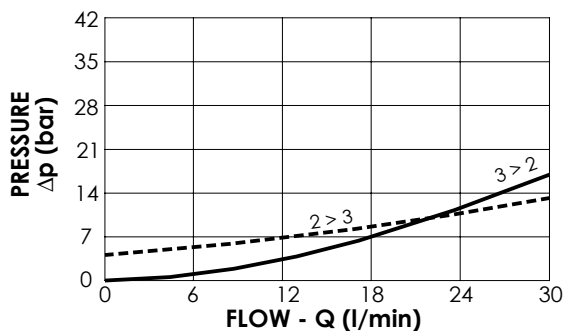

**ORDERING CODES**

Quick code	Description	Cracking pressure (bar)	O-Ring on pilot piston	
SC000002	CDPN-030-PSNE-07-028-N005	4,5	YES	
SC000044	CDPN-030-PSNN-07-028-N005	4,5	NO	



PILOT OPERATED CHECK VALVE

**CDPN-050-PSNN**

SEPARATE PILOT  
PISTON

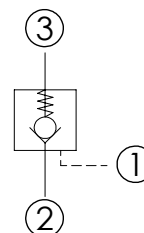
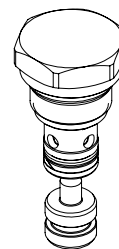
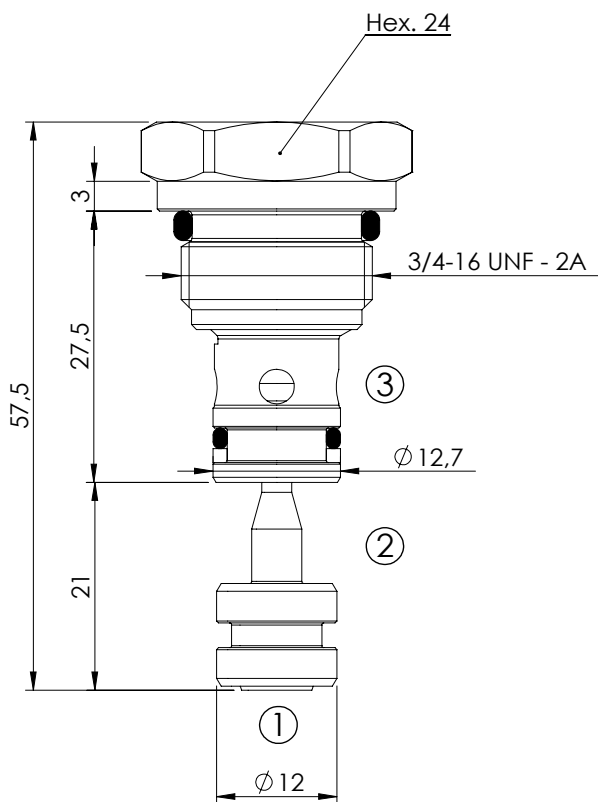

**SPECIFICATIONS**

Max. operating pressure:	350 bar
Rated flow:	50 l/min
Cavity:	VP000193
Weight:	0,07 kg
Pilot ratio:	4:1

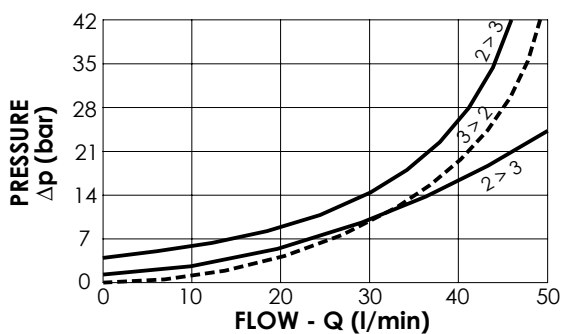

**NOTES**

Installation torque:	45 - 50 Nm
Seal kit:	RC700193

**ORDERING CODES**

Quick code	Description	Cracking pressure (bar)	O-Ring on pilot piston	
SC000051	CDPN-050-PSNN-04-193-N001	1	NO	
SC000056	CDPN-050-PSNN-04-193-N003	3	NO	
SC000057	CDPN-050-PSNE-04-193-N003	3	YES	

PILOT OPERATED CHECK VALVE

**CDPN-060-PSNN**

SEPARATE PILOT  
PISTON

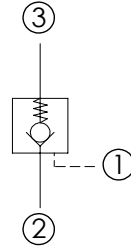
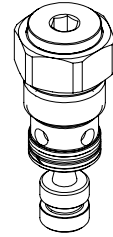
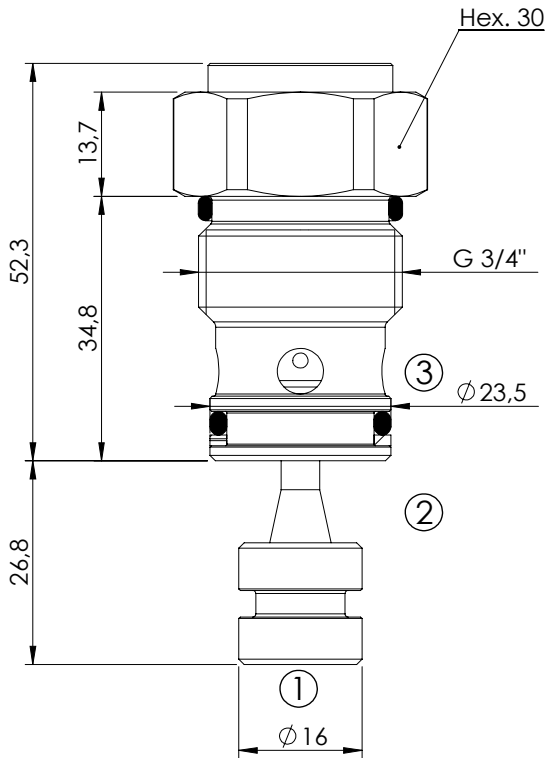

**SPECIFICATIONS**

Max. operating pressure:	350 bar
Rated flow:	60 l/min
Cavity:	VP000038
Weight:	0,2 kg
Pilot ratio:	3:1

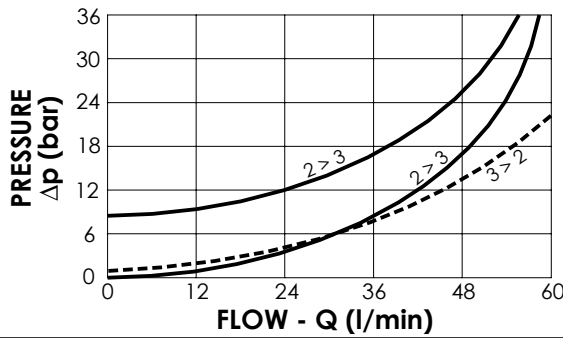

**NOTES**

Installation torque:	100 - 130 Nm
Seal kit:	RC700038

**ORDERING CODES**

Quick code	Description	Cracking pressure (bar)	O-Ring on pilot piston	
SC000052	CDPN-060-PSNN-03-038-N001	1	NO	
SC000054	CDPN-060-PSNN-03-038-N008	8	NO	
SC000055	CDPN-060-PSNE-03-038-N008	8	YES	

PILOT OPERATED CHECK VALVE

**MCSN-020-SLAC**

SINGLE ACTING

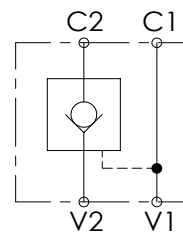
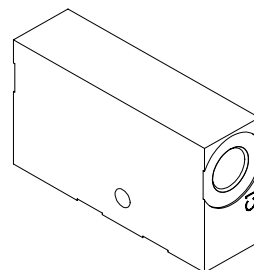
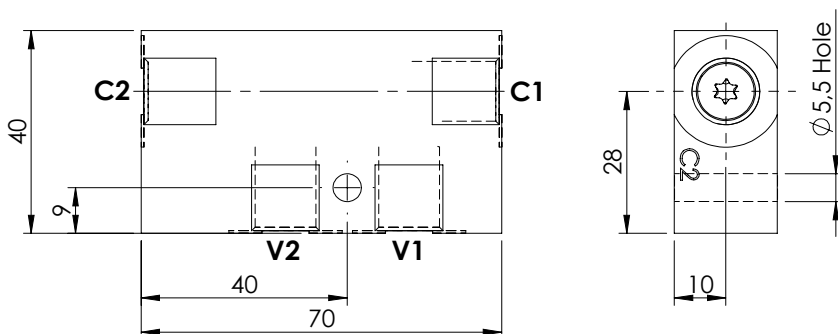
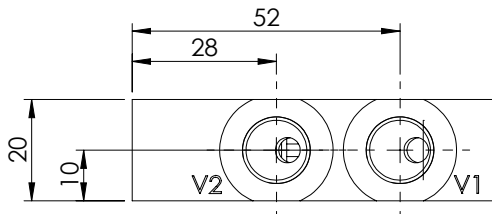

**SPECIFICATIONS**

Max. operating pressure:	350 bar
Rated flow:	20 l/min
Manifold:	Steel
Weight:	0,36 kg

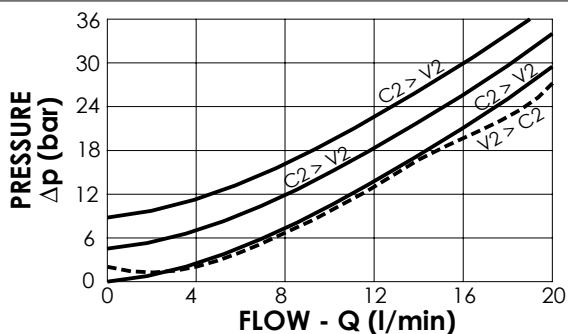

**ORDERING CODES**

Quick code	Description	Main ports size	Pilot ratio	Cracking pressure (bar)	O-Ring on pilot piston
MC000059	MCSN-020-SLAC-04-G14-N003	V1,V2,C1,C2 : G 1/4"	4:1	3	YES
MC000094	MCSN-020-SLAC-04-G14-N008	V1,V2,C1,C2 : G 1/4"	4:1	8	YES
MC000097	MCSN-020-SLAC-07-G14-N005	V1,V2,C1,C2 : G 1/4"	7:1	5	YES

PILOT OPERATED CHECK VALVE

**MCSN-030-TLNS**

SINGLE ACTING

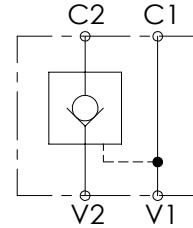
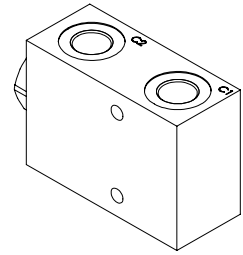
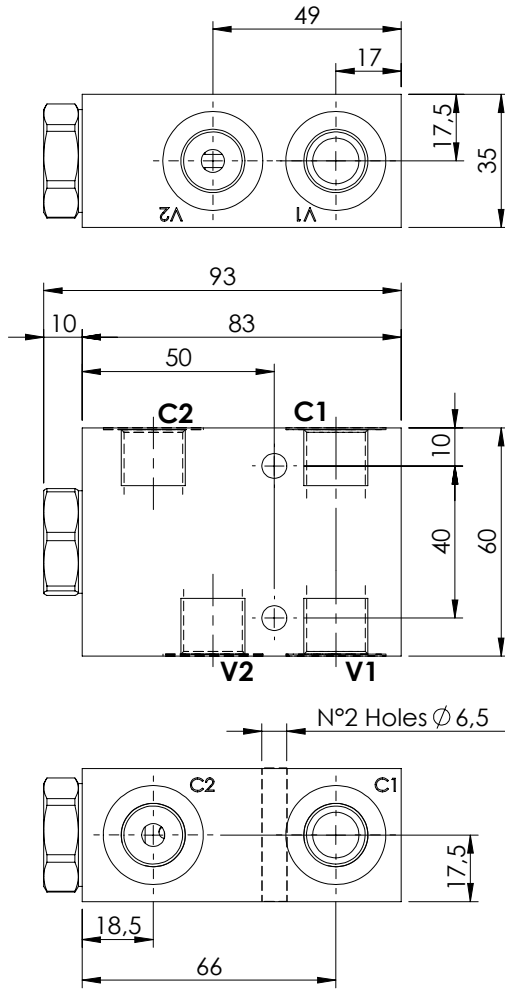

**SPECIFICATIONS**

Max. operating pressure:	350 bar
Rated flow:	30 l/min
Manifold:	Aluminium
Weight:	0,49 kg

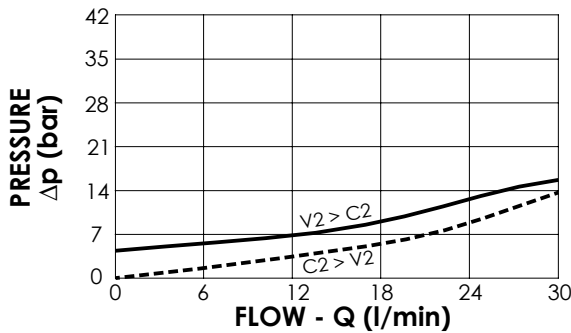

**ORDERING CODES**

Quick code	Description	Main ports size	Pilot ratio	Cracking pressure (bar)	O-Ring on pilot piston
MC000078	MCSN-030-TLNS-07-G38-N005	V1,V2,C1,C2 : G 3/8"	7:1	5	NO
MC000075	MCSN-030-TLNC-07-G38-N005	V1,V2,C1,C2 : G 3/8"	7:1	5	YES

PILOT OPERATED CHECK VALVE

**MCSN-030-TANS**

**SINGLE ACTING  
ONE FLANGED PORT**

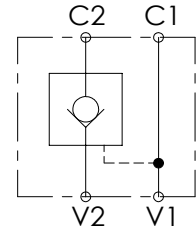
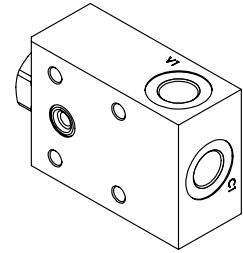
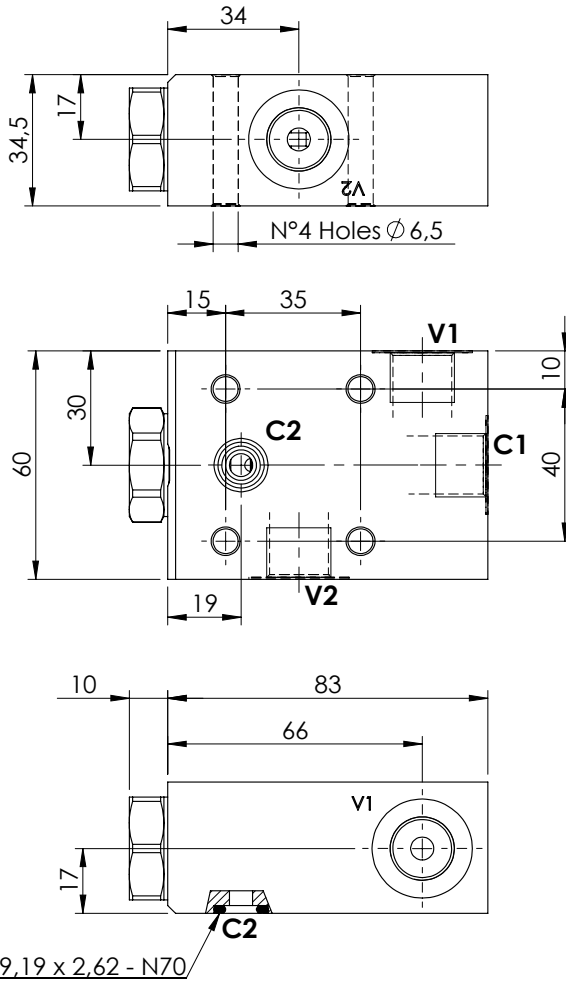

**SPECIFICATIONS**

Max. operating pressure:	350 bar
Rated flow:	30 l/min
Manifold:	Aluminium
Weight:	0,49 kg

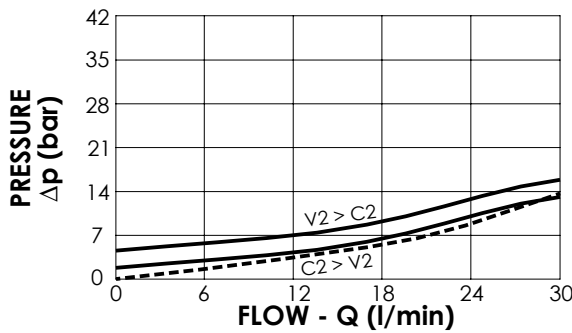

**ORDERING CODES**

Quick code	Description	Main ports size	Pilot ratio	Cracking pressure (bar)	O-Ring on pilot piston
MC000064	MCSN-030-TANS-07-G38-N001	V1,V2,C1: G 3/8" C2: Ø 6	7:1	1	NO
MC000066	MCSN-030-TANS-07-G38-N005	V1,V2,C1: G 3/8" C2: Ø 6	7:1	5	NO
MC000068	MCSN-030-TANC-07-G38-N005	V1,V2,C1: G 3/8" C2: Ø 6	7:1	5	YES

PILOT OPERATED CHECK VALVE

**MCSN-060-TLNS**

SINGLE ACTING

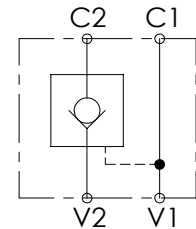
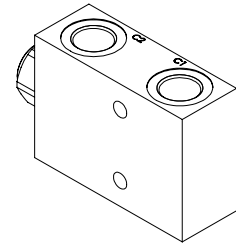
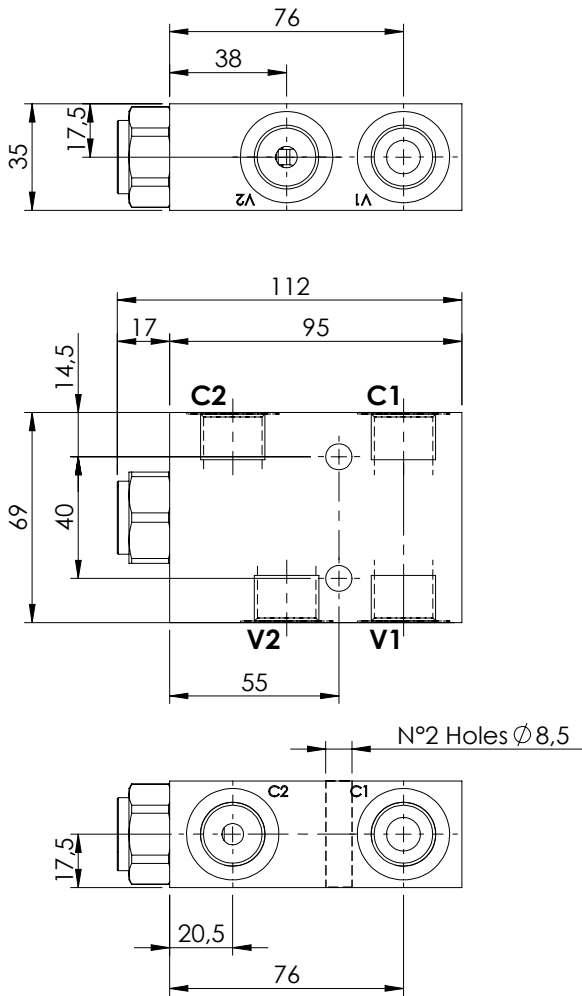

**SPECIFICATIONS**

Max. operating pressure:	350 bar
Rated flow:	60 l/min
Manifold:	Aluminium
Weight:	0,66 kg

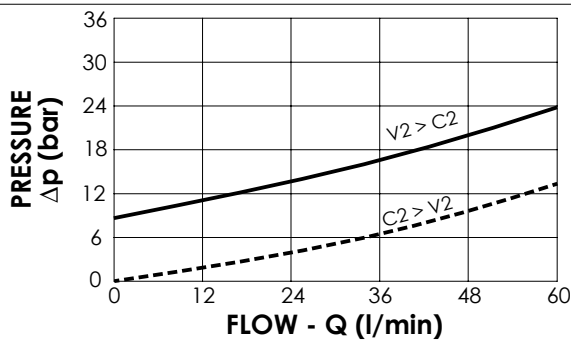

**ORDERING CODES**

Quick code	Description	Main ports size	Pilot ratio	Cracking pressure (bar)	O-Ring on pilot piston
MC000079	MCSN-060-TLNS-03-G12-N008	V1,V2,C1,C2 : G 1/2"	3:1	8	NO
MC000076	MCSN-060-TLNC-03-G12-N008	V1,V2,C1,C2 : G 1/2"	3:1	8	YES

PILOT OPERATED CHECK VALVE

**MCSN-060-TANS**

**SINGLE ACTING  
ONE FLANGED PORT**

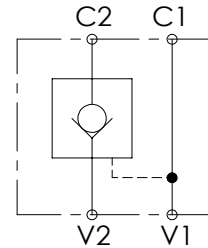
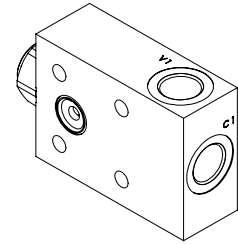
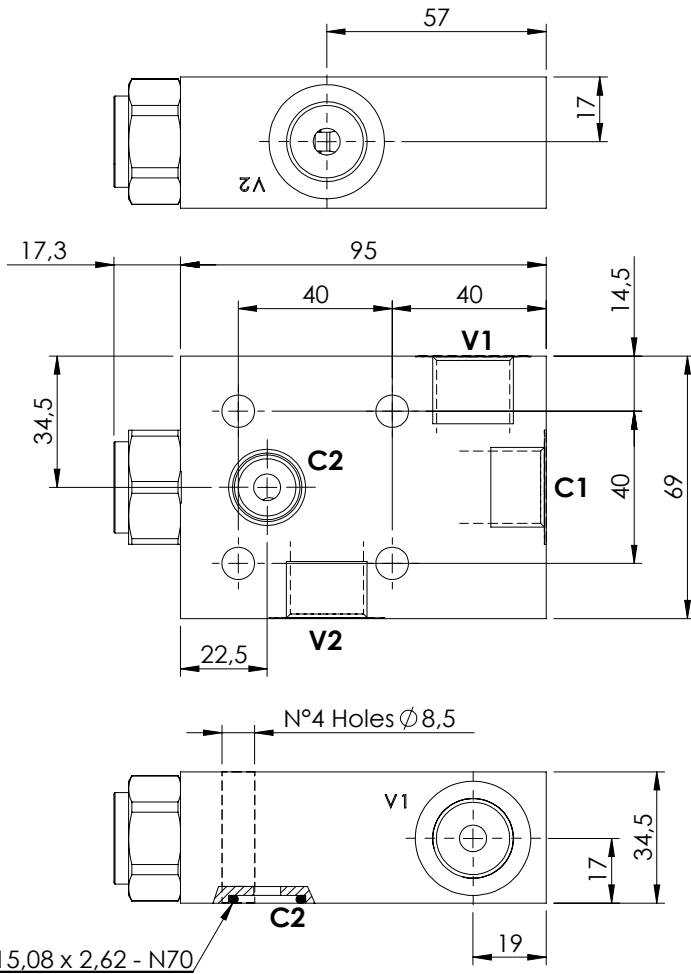

**SPECIFICATIONS**

Max. operating pressure:	350 bar
Rated flow:	60 l/min
Manifold:	Aluminium
Weight:	0,66 kg

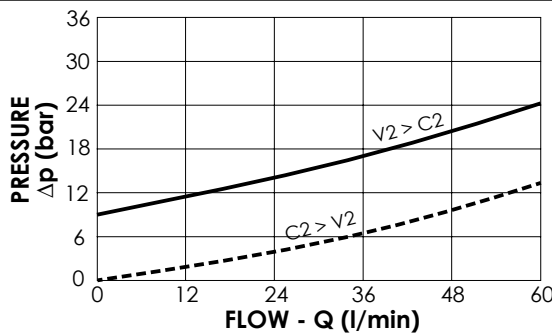

**ORDERING CODES**

Quick code	Description	Main ports size	Pilot ratio	Cracking pressure (bar)	O-Ring on pilot piston
MC000080	MCSN-060-TANS-03-G12-N008	V1,V2,C1: G 1/2" C2: Ø 7	3:1	8	NO
MC000077	MCSN-060-TANC-03-G12-N008	V1,V2,C1: G 1/2" C2: Ø 7	3:1	8	YES

PILOT OPERATED CHECK VALVE

**MCSN-100-TLNS**

**SINGLE ACTING**

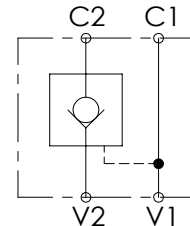
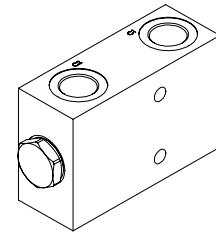
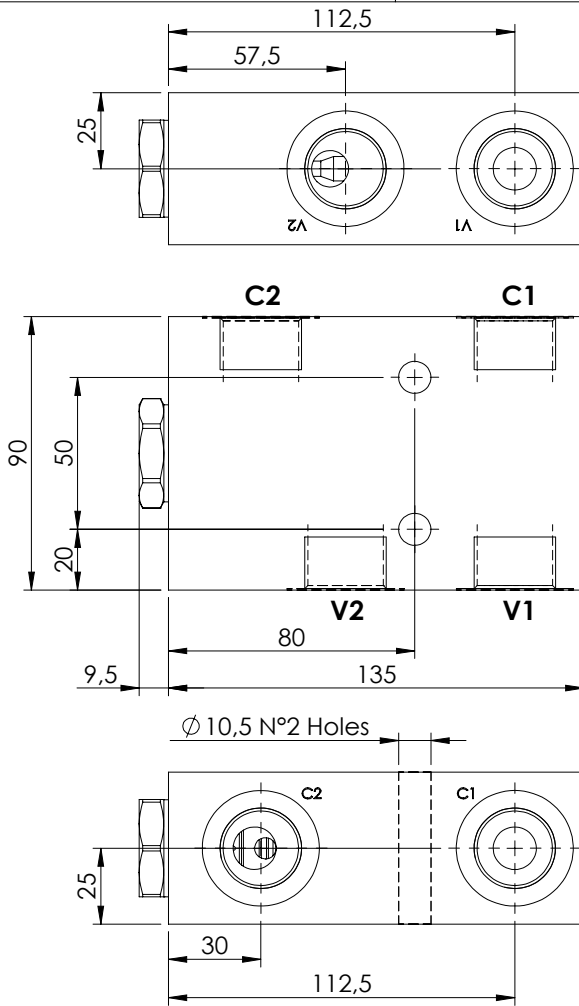

**SPECIFICATIONS**

Max. operating pressure:	350 bar
Rated flow:	100 l/min
Manifold:	Aluminium
Weight:	1,5 kg

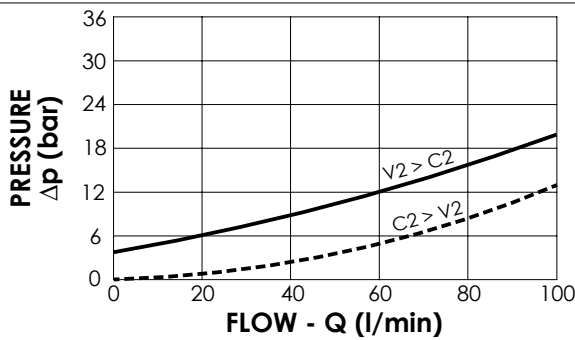

**ORDERING CODES**

Quick code	Description	Main ports size	Pilot ratio	Cracking pressure (bar)	O-Ring on pilot piston
MC000148	MCSN-100-TLNS-04-G34-N004	V1,V2,C1,C2 : G 3/4"	4:1	4	NO



PILOT OPERATED CHECK VALVE

**MCSN-020-TLLC**

**SINGLE ACTING  
MANUAL SHUT OFF  
LEFT VERSION**

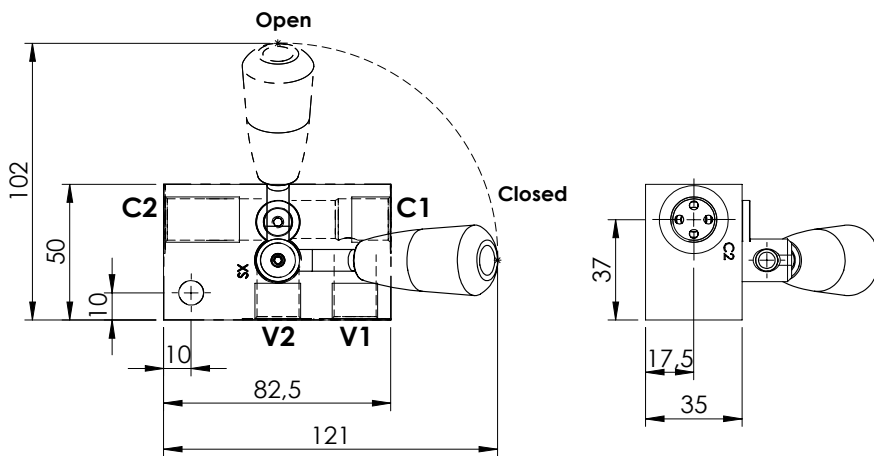
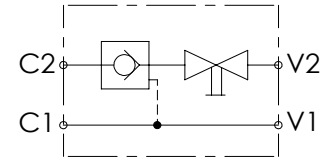
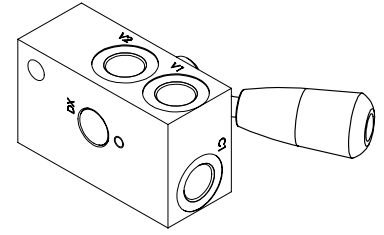
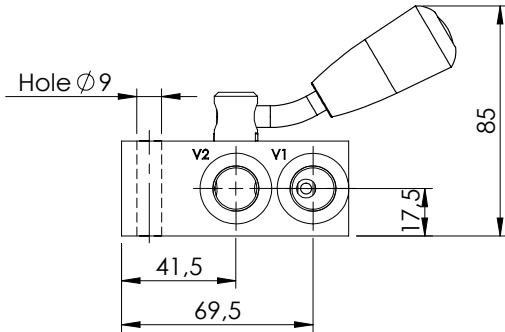

**SPECIFICATIONS**

Max. operating pressure:	350 bar
Rated flow:	20 l/min
Manifold:	Aluminium
Weight:	0,45 kg

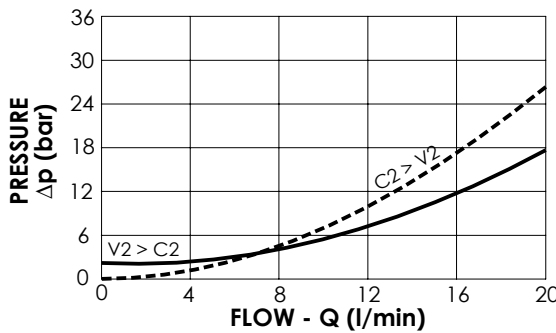

**ORDERING CODES**

Quick code	Description	Main ports size	Pilot ratio	Cracking pressure (bar)	O-Ring on pilot piston
MC000062	MCSN-020-TLLC-05-G38-N002	V1,V2,C1,C2 : G 3/8"	5:1	2	YES

PILOT OPERATED CHECK VALVE

**MCSN-020-TLRC**

**SINGLE ACTING  
MANUAL SHUT OFF  
RIGHT VERSION**

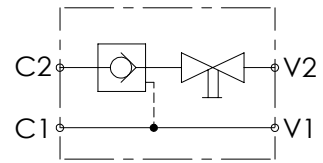
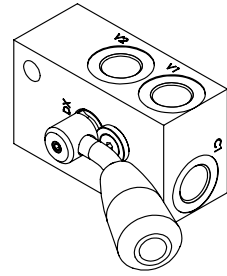
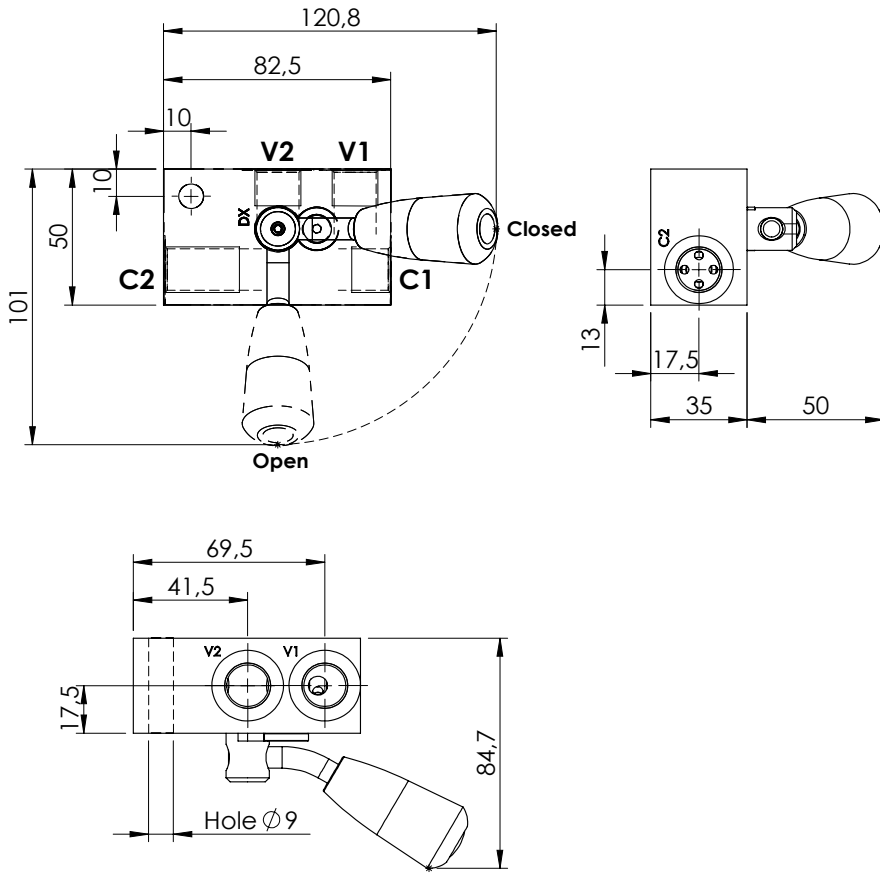

**SPECIFICATIONS**

Max. operating pressure:	350 bar
Rated flow:	20 l/min
Manifold:	Aluminium
Weight:	0,45 kg

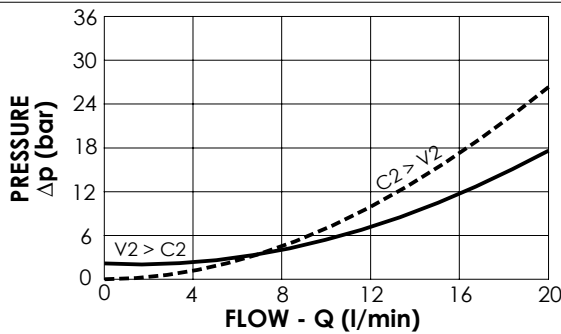

**ORDERING CODES**

Quick code	Description	Main ports size	Pilot ratio	Cracking pressure (bar)	O-Ring on pilot piston
MC000061	MCSN-020-TLRC-05-G38-N002	V1,V2,C1,C2 : G 3/8"	5:1	2	YES

PILOT OPERATED CHECK VALVE

**MCDN-020-SLAS**

**DOUBLE ACTING**

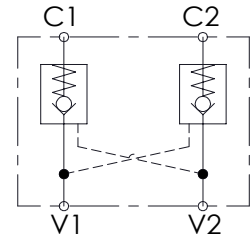
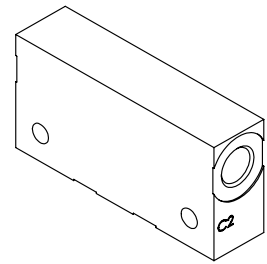
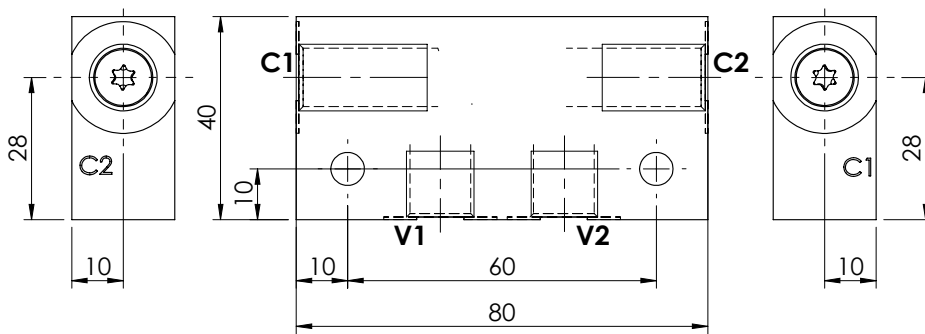
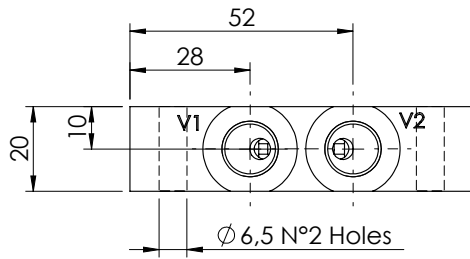

**SPECIFICATIONS**

Max. operating pressure:	350 bar
Rated flow:	20 l/min
Manifold:	Steel
Weight:	0,42 kg

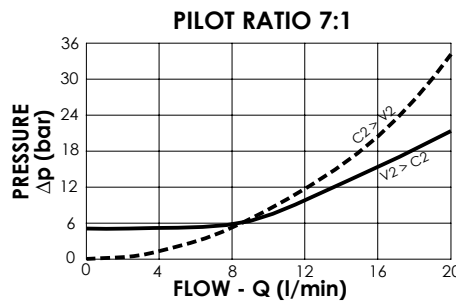
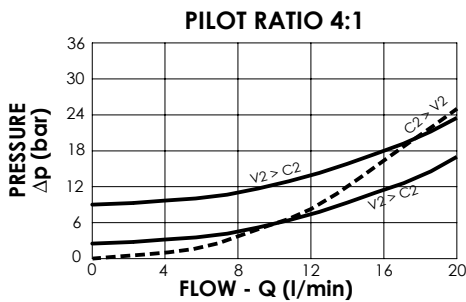

**ORDERING CODES**

Quick code	Description	Main ports size	Pilot ratio	Cracking pressure (bar)	O-Ring on pilot piston
MC000113	MCDN-020-SLAS-04-G14-N003	V1,V2,C1,C2 : G 1/4"	4:1	3	NO
MC000160	MCDN-020-SLAS-04-G14-N008	V1,V2,C1,C2 : G 1/4"	4:1	8	NO
MC000227	MCDN-020-SLAS-07-G14-N005	V1,V2,C1,C2 : G 1/4"	7:1	5	NO

PILOT OPERATED CHECK VALVE

**MCDN-020-SLAS**

**DOUBLE ACTING**

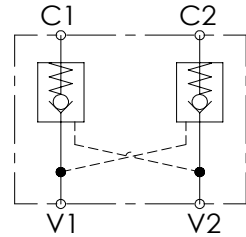
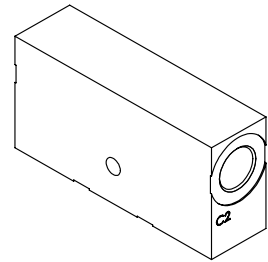
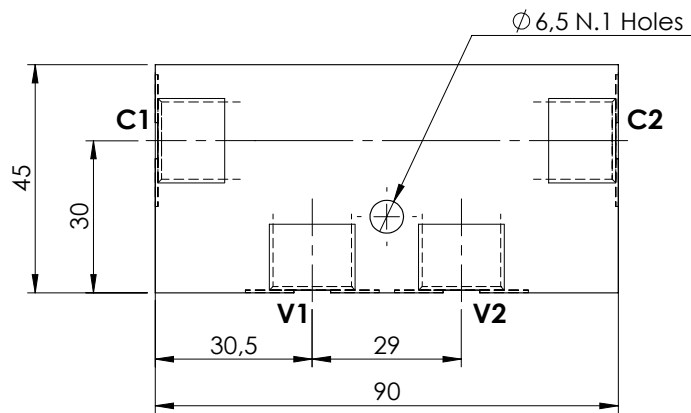
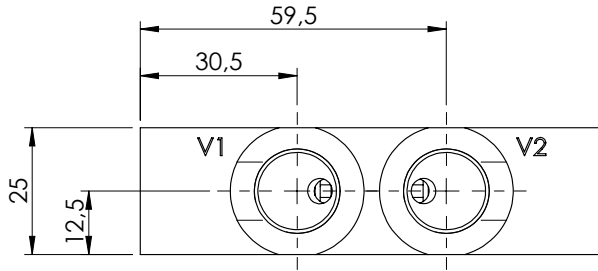

**SPECIFICATIONS**

Max. operating pressure:	350 bar
Rated flow:	20 l/min
Manifold:	Steel
Weight:	0,67 kg

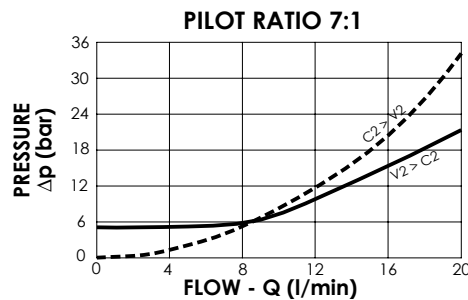
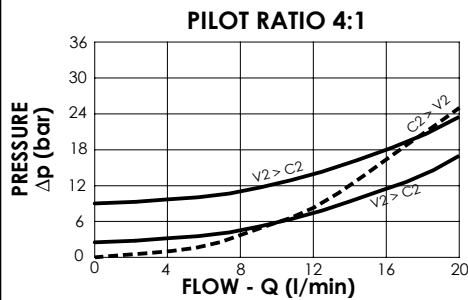

**ORDERING CODES**

Quick code	Description	Main ports size	Pilot ratio	Cracking pressure (bar)	O-Ring on pilot piston
MC000174	MCDN-020-SLAS-04-G38-N003	V1,V2,C1,C2 : G 3/8"	4:1	3	NO
MC000213	MCDN-020-SLAS-04-G38-N009	V1,V2,C1,C2 : G 3/8"	4:1	9	NO
MC000212	MCDN-020-SLAS-04-G38-N005	V1,V2,C1,C2 : G 3/8"	7:1	5	NO

PILOT OPERATED CHECK VALVE

**MCDN-020-SLGS**

DOUBLE ACTING  
WITH BANJO

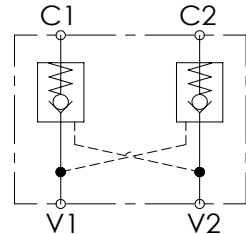
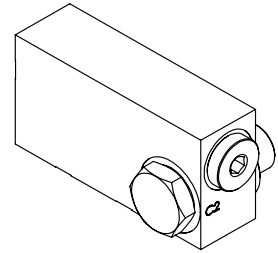
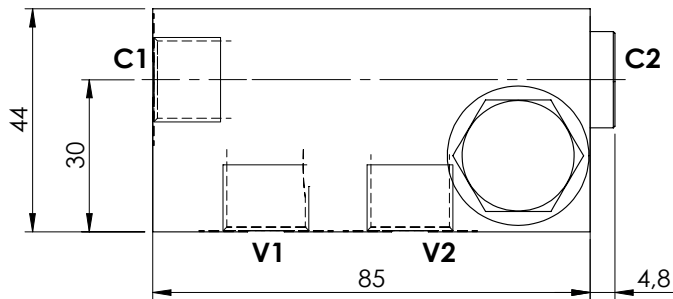
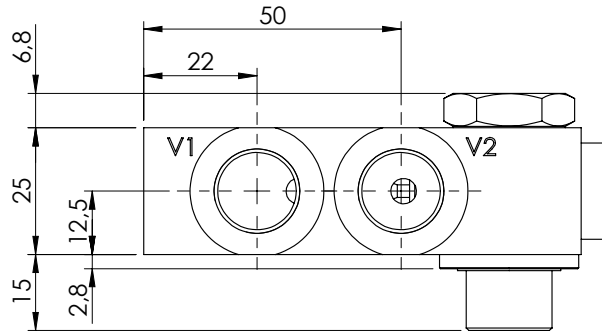

**SPECIFICATIONS**

Max. operating pressure:	350 bar
Rated flow:	20 l/min
Manifold:	Steel
Weight:	0,68 kg

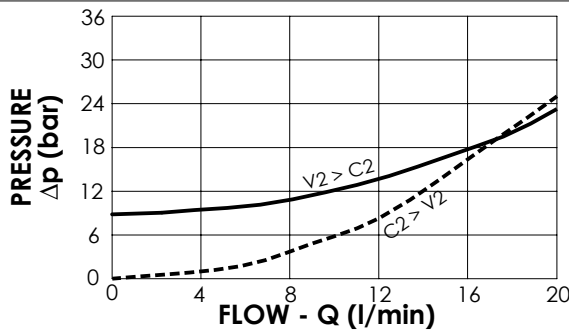

**ORDERING CODES**

Quick code	Description	Main ports size	Pilot ratio	Cracking pressure (bar)	O-Ring on pilot piston
MC000208	MCDN-020-SLGS-04-G38-N010	V1,V2,C1,C2 : G 3/8"	4:1	10	NO

PILOT OPERATED CHECK VALVE

**MCDN-030-TLNS**

DOUBLE ACTING

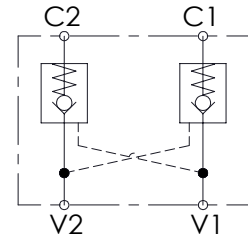
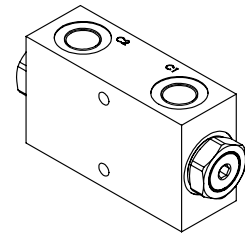
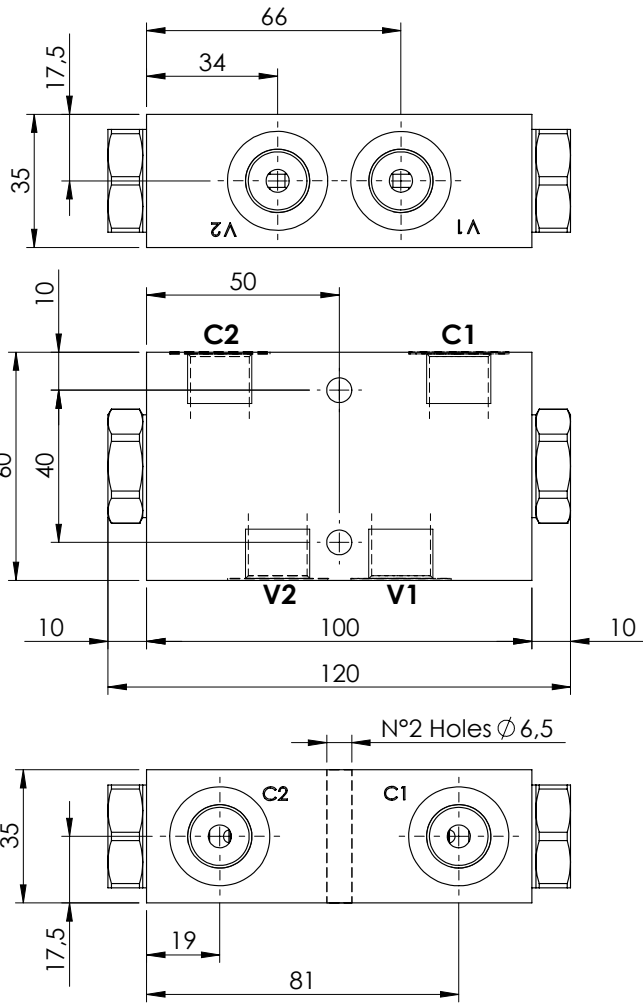

**SPECIFICATIONS**

Max. operating pressure:	350 bar
Rated flow:	30 l/min
Manifold:	Aluminium
Weight:	0,67 kg

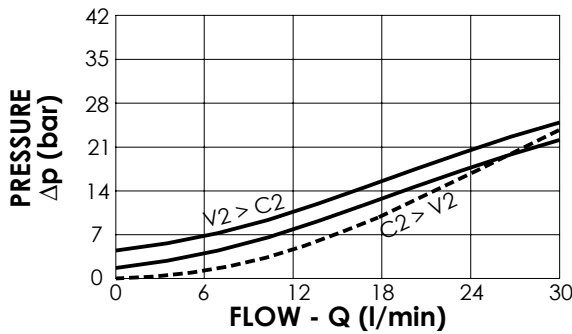

**ORDERING CODES**

Quick code	Description	Main ports size	Pilot ratio	Cracking pressure (bar)	O-Ring on pilot piston
MC000002	MCDN-030-TLNS-07-G38-N001	V1,V2,C1,C2 : G 3/8"	7:1	1	NO
MC000009	MCDN-030-TLNS-07-G38-N005	V1,V2,C1,C2 : G 3/8"	7:1	5	NO
MC000010	MCDN-030-TLNC-07-G38-N005	V1,V2,C1,C2 : G 3/8"	7:1	5	YES

PILOT OPERATED CHECK VALVE

**MCDN-030-ZBNS**

DOUBLE ACTING  
TWO FLANGED PORTS

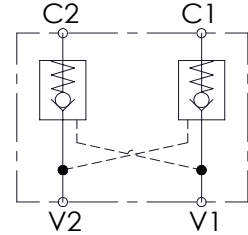
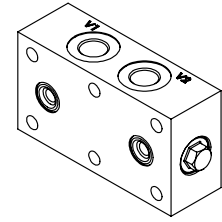
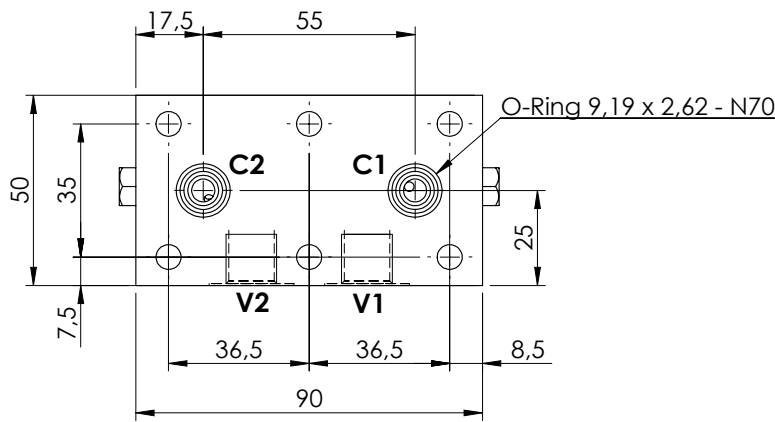
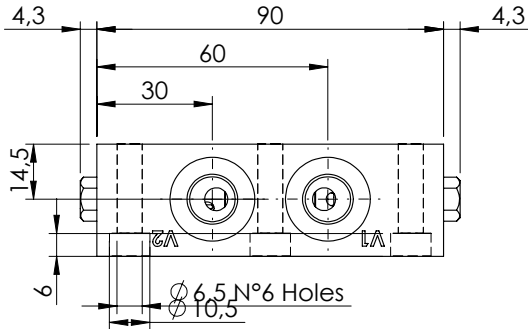

**SPECIFICATIONS**

Max. operating pressure:	350 bar
Rated flow:	30 l/min
Manifold:	Aluminium
Weight:	0,67 kg

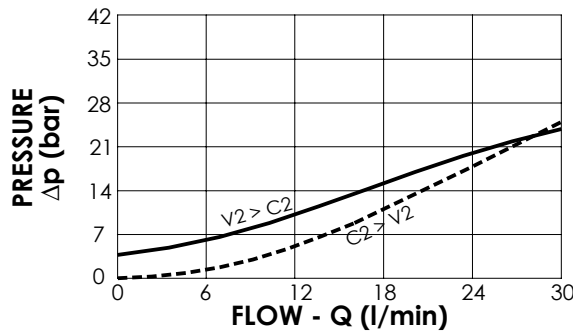

**ORDERING CODES**

Quick code	Description	Main ports size	Pilot ratio	Cracking pressure (bar)	O-Ring on pilot piston
MC000086	MCDN-030-ZBNS-04-G14-N004	V1,V2:G 1/4" C1,C2: Ø 6	4:1	4	NO

PILOT OPERATED CHECK VALVE

**MCDN-030-TBNS**

DOUBLE ACTING  
TWO FLANGED PORTS

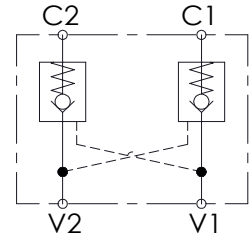
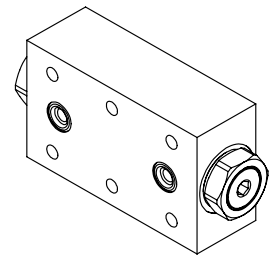
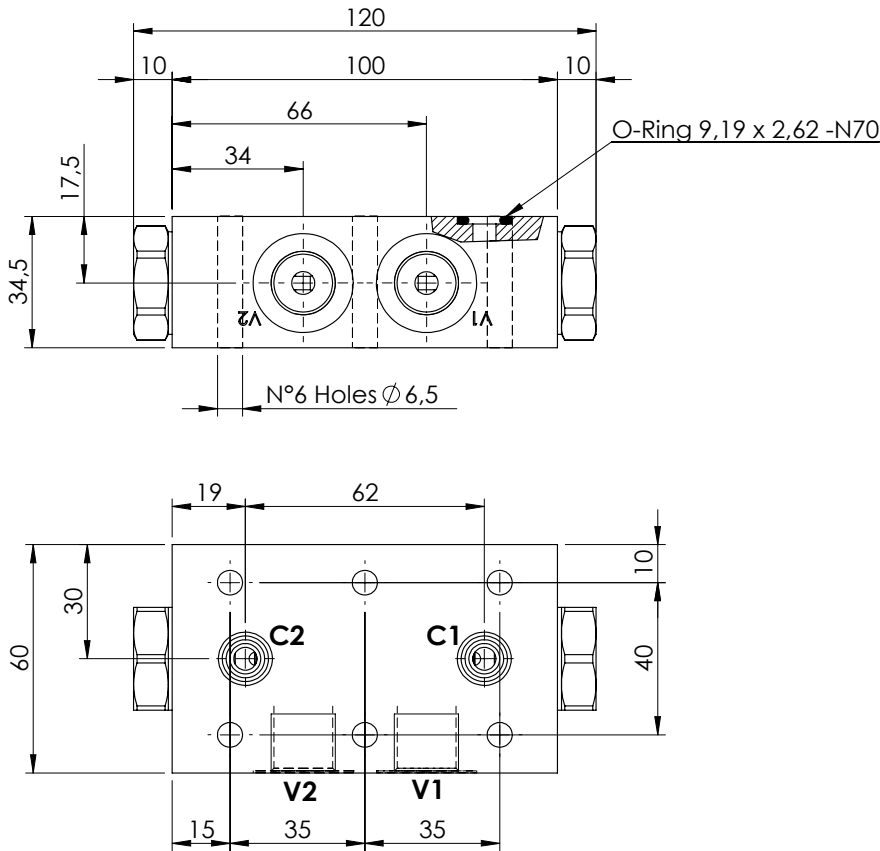

**SPECIFICATIONS**

Max. operating pressure:	350 bar
Rated flow:	30 l/min
Manifold:	Aluminium
Weight:	0,67 kg

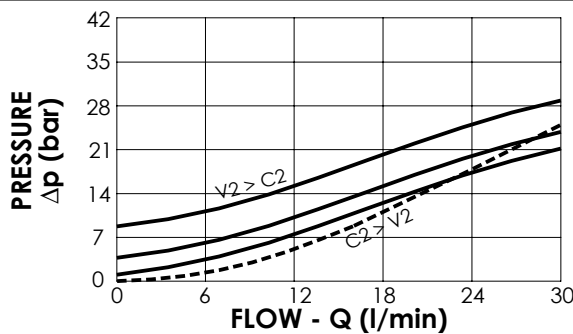

**ORDERING CODES**

Quick code	Description	Main ports size	Pilot ratio	Cracking pressure (bar)	O-Ring on pilot piston
MC000005	MCDN-030-TBNS-07-G38-N001	V1,V2:G 3/8" C1,C2: Ø 6	7:1	1	NO
MC000012	MCDN-030-TBNS-07-G38-N005	V1,V2:G 3/8" C1,C2: Ø 6	7:1	5	NO
MC000020	MCDN-030-TBNC-07-G38-N005	V1,V2:G 3/8" C1,C2: Ø 6	7:1	5	YES
MC000092	MCDN-030-TBNS-07-G38-N009	V1,V2:G 3/8" C1,C2: Ø 6	7:1	9	NO
MC000195	MCDN-030-TBNC-07-G38-N009	V1,V2:G 3/8" C1,C2: Ø 6	7:1	9	YES



PILOT OPERATED CHECK VALVE

**MCDN-030-SBNS**

**DOUBLE ACTING  
TWO FLANGED PORTS**

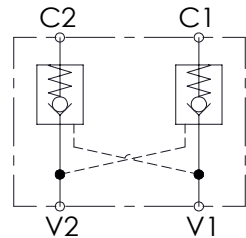
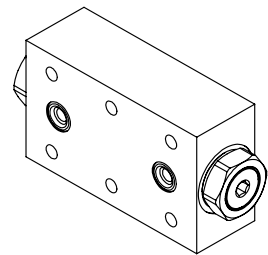
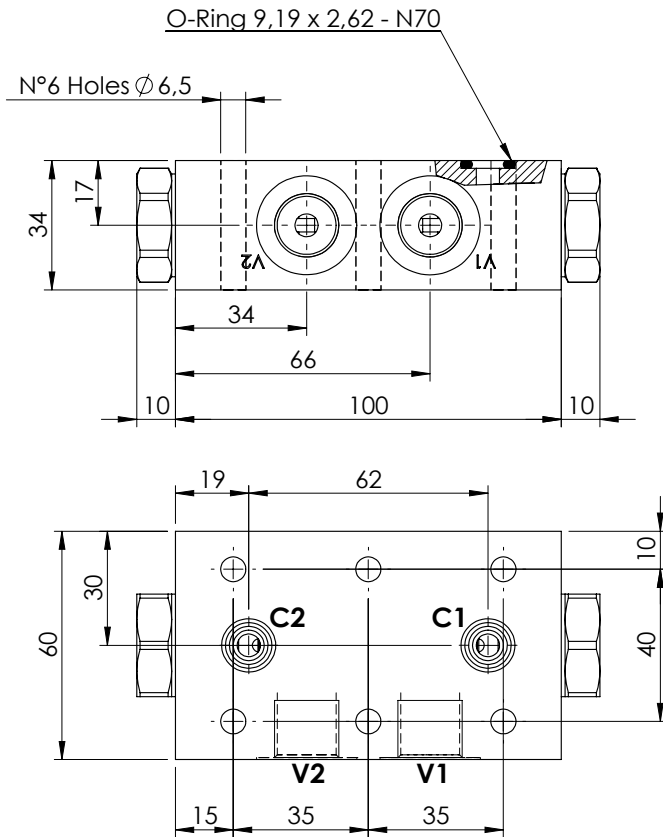

**SPECIFICATIONS**

Max. operating pressure:	350 bar
Rated flow:	30 l/min
Manifold:	Steel
Weight:	1,49 kg

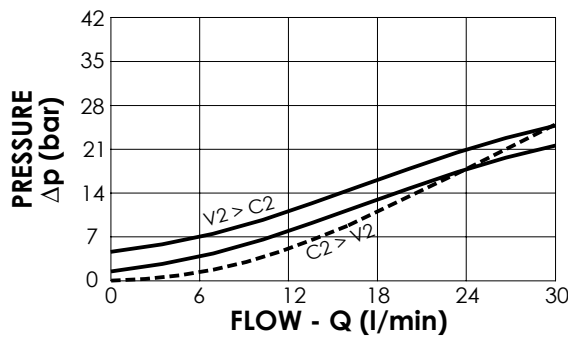

**ORDERING CODES**

Quick code	Description	Main ports size	Pilot ratio	Cracking pressure (bar)	O-Ring on pilot piston
MC000036	MCDN-030-SBNS-07-G38-N005	V1,V2:G 3/8" C1,C2:Ø 6	7:1	5	NO
MC000037	MCDN-030-SBNC-07-G38-N005	V1,V2:G 3/8" C1,C2:Ø 6	7:1	5	YES
MC000038	MCDN-030-SBNS-07-G38-N001	V1,V2:G 3/8" C1,C2:Ø 6	7:1	1	NO

PILOT OPERATED CHECK VALVE

**MCDN-060-TLNS**

**DOUBLE ACTING**

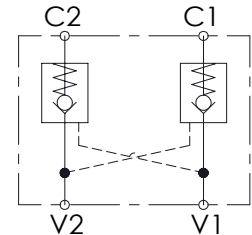
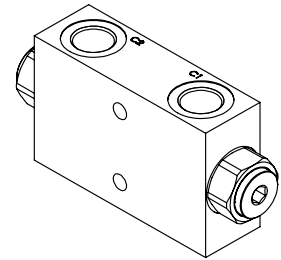
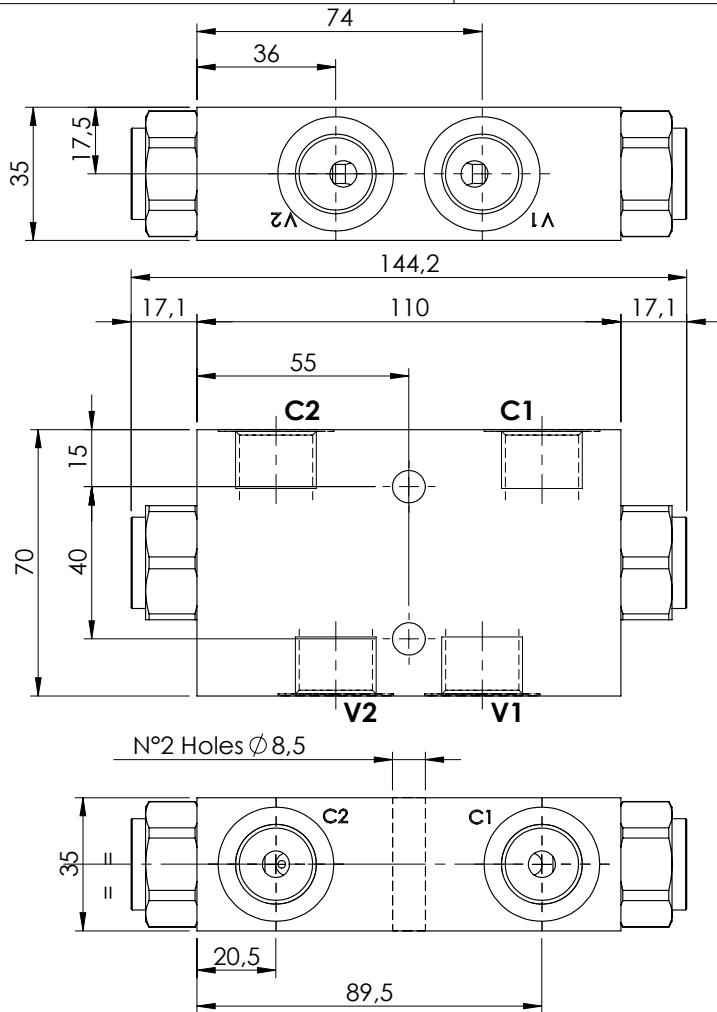

**SPECIFICATIONS**

Max. operating pressure:	350 bar
Rated flow:	60 l/min
Manifold:	Aluminium
Weight:	0,9 kg

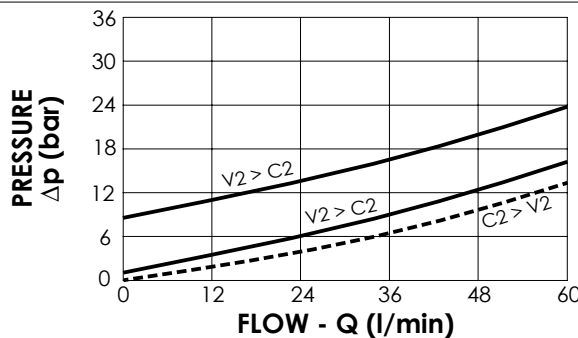

**ORDERING CODES**

Quick code	Description	Main ports size	Pilot ratio	Cracking pressure (bar)	O-Ring on pilot piston
MC000042	MCDN-060-TLNS-03-G12-N001	V1,V2,C1,C2 : G1/2"	3:1	1	NO
MC000040	MCDN-060-TLNS-03-G12-N008	V1,V2,C1,C2 : G1/2"	3:1	8	NO
MC000041	MCDN-060-TLNC-03-G12-N008	V1,V2,C1,C2 : G1/2"	3:1	8	YES

PILOT OPERATED CHECK VALVE

**MCDN-060-TBNS**

**DOUBLE ACTING  
TWO FLANGED PORTS**

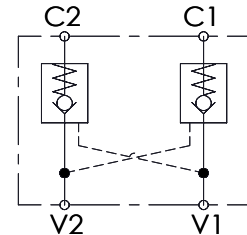
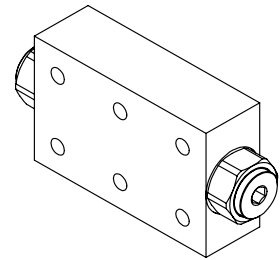
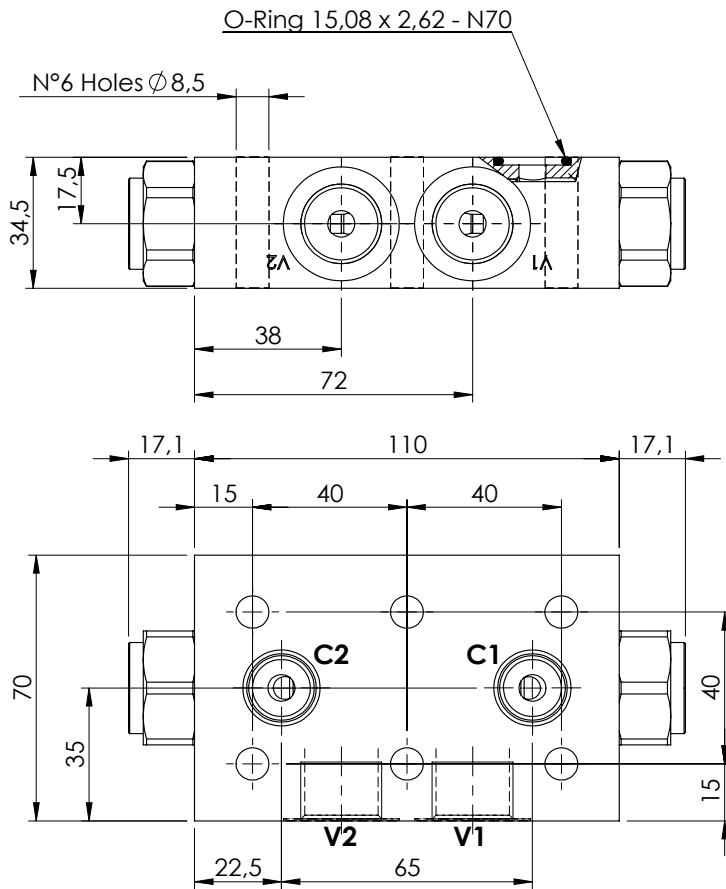

**SPECIFICATIONS**

Max. operating pressure:	350 bar
Rated flow:	60 l/min
Manifold:	Aluminium
Weight:	0,90 kg

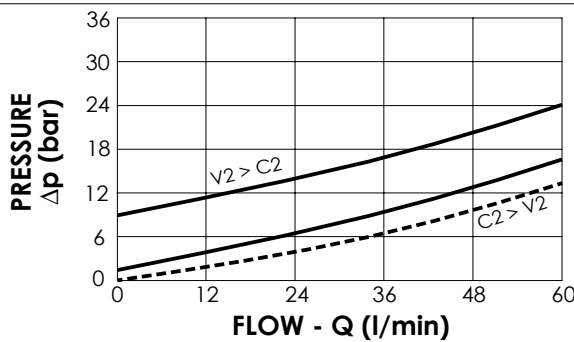

**ORDERING CODES**

Quick code	Description	Main ports size	Pilot ratio	Cracking pressure (bar)	O-Ring on pilot piston
MC000029	MCDN-060-TBNS-03-G12-N001	V1,V2:G 1/2" C1,C2: Ø 7	3:1	1	NO
MC000027	MCDN-060-TBNS-03-G12-N008	V1,V2:G 1/2" C1,C2: Ø 7	3:1	8	NO
MC000028	MCDN-060-TBNC-03-G12-N008	V1,V2:G 1/2" C1,C2: Ø 7	3:1	8	YES
MC000026	MCDN-060-TBNS-06-G12-N001	V1,V2:G 1/2" C1,C2: Ø 7	6:1	1	NO
MC000025	MCDN-060-TBNS-06-G12-N008	V1,V2:G 1/2" C1,C2: Ø 7	6:1	8	NO
MC000022	MCDN-060-TBNC-06-G12-N008	V1,V2:G 1/2" C1,C2: Ø 7	6:1	8	YES

PILOT OPERATED CHECK VALVE

**MCDN-100-LLNR**

**DOUBLE ACTING**

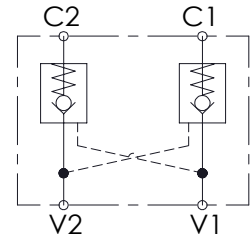
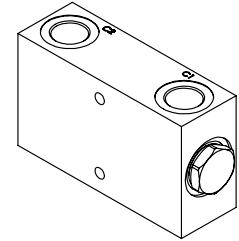
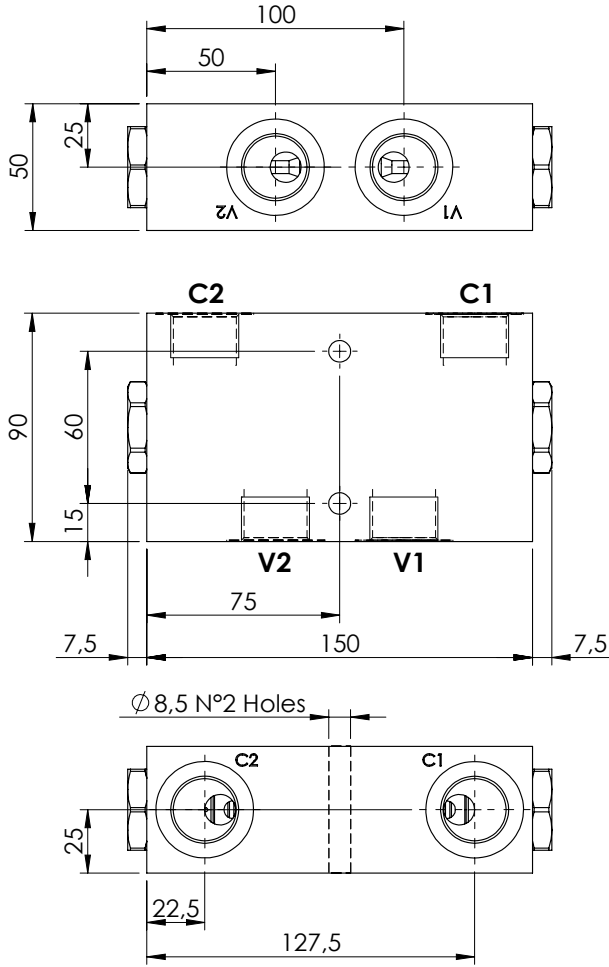

**SPECIFICATIONS**

Max. operating pressure:	350 bar
Rated flow:	100 l/min
Manifold:	Aluminium
Weight:	1,8 kg

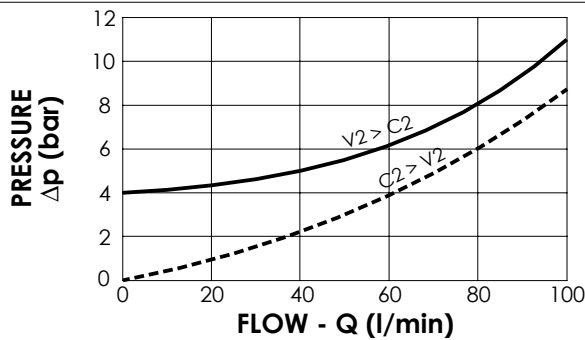

**ORDERING CODES**

Quick code	Description	Main ports size	Pilot ratio	Cracking pressure (bar)	O-Ring on pilot piston
MC000144	MCDN-100-LLNR-04-G34-N004	V1,V2,C1,C2 : G3/4"	4:1	4	NO