



Level switch for tank installation

NT M...-Atex



Installation and Operation Instructions

Original instructions



1800-OILSOL
1800-645765

<https://oilsolutions.com.au/>

sales@oilsolutions.com.au





Bühler Technologies GmbH, Harkortstr. 29, D-40880 Ratingen
Tel. +49 (0) 21 02 / 49 89-0, Fax: +49 (0) 21 02 / 49 89-20
Internet: www.buehler-technologies.com
E-Mail: fluidcontrol@buehler-technologies.com

Read this instruction carefully prior to installation and/or use. Pay attention particularly to all advises and safety instructions to prevent injuries. Bühler Technologies can not be held responsible for misusing the product or unreliable function due to unauthorised modifications.

All rights reserved. Bühler Technologies GmbH 2022

Document information

Document No..... BE100011
Version..... 02/2022
Part No..... 9031274



1800-OILSOL
1800-645765

<https://oilsolutions.com.au/>

sales@oilsolutions.com.au

Contents

1	Introduction.....	2
1.1	Intended Use.....	2
1.2	Layout and Functionality.....	2
1.3	Scope of Delivery.....	2
1.4	Type plate.....	2
1.5	Model Key.....	3
2	Safety instructions.....	4
2.1	Important advice.....	4
2.2	General hazard warnings.....	5
3	Transport and storage.....	6
4	Installation and connection.....	7
4.1	Installation.....	7
4.2	Electrical connections.....	7
4.2.1	PA connection (potential equalisation).....	7
4.2.2	Intrinsically-safe connection.....	8
5	Operation and control.....	9
6	Cleaning and Maintenance.....	11
7	Service and repair.....	12
8	Disposal.....	13
9	Appendices.....	14
9.1	Technical Data.....	14
9.2	Standard pin assignment.....	15
9.3	Definitions.....	16
10	Attached documents.....	17



1 Introduction

1.1 Intended Use

The level switches are used to monitor levels and temperatures inside a tank. The measuring tube is inside the tank during the process.

According to EN 60079-11, NT M...-Atex series level switches are simple electrical apparatuses without separate voltage source intended for tank top installation.

When used in explosive areas these types may only be operated on intrinsically-safe circuits. With intrinsically safe connection they may be installed in Zone 2 explosive areas.

Never use the level switches in highly flammable or corrosive liquids. The medium must not contain particles, particularly metallic particles, to prevent deposits on the float or between the float and switching tube.

Before installing the level switches, verify the listed technical data meet the application parameters. Also observe the applicable requirements of EN 60079-14.

Further verify all contents are complete.

Please note the specific values of the level switches when connecting and the correct version when ordering spare parts.

1.2 Layout and Functionality

The height adjustable level contacts (bistable reed contacts) and temperature contacts (bimetal disc thermostat) are located inside the measuring tube. The level contacts are activated by a magnet inside the level switch float.

The temperature is monitored via thermal element mounted to the end of the rail. Choose from temperature contacts with fixed increments or a resistance thermometer (Pt100).

It installs to the tank via the female thread on the level switch.

1.3 Scope of Delivery

- Level switch
- Elastic profile gasket (NBR) M27x2 (G 3/4)
- Product Documentation

1.4 Type plate

Example:

Manufacturer and address	→	Bühler Technologies GmbH Harkortstr. 29 D-40880 Ratingen
Model designation	→	Nivotemp M-0-Atex-MS-M3/var
Order no.+Item no.+Metre	→	1006299A KW: 7-2018 001
Controller values	→	⊕ Ui=30V, li= 50mA , Pi=100mW
Temperature specifications	→	T Medium < 80°C, -20°C < Ta < 80°C
Pressure specifications	→	p max. = 1bar, SIMPLE APPARATUS
Year of manufacture	→	Read manual! Year: 2018

1.5 Model Key

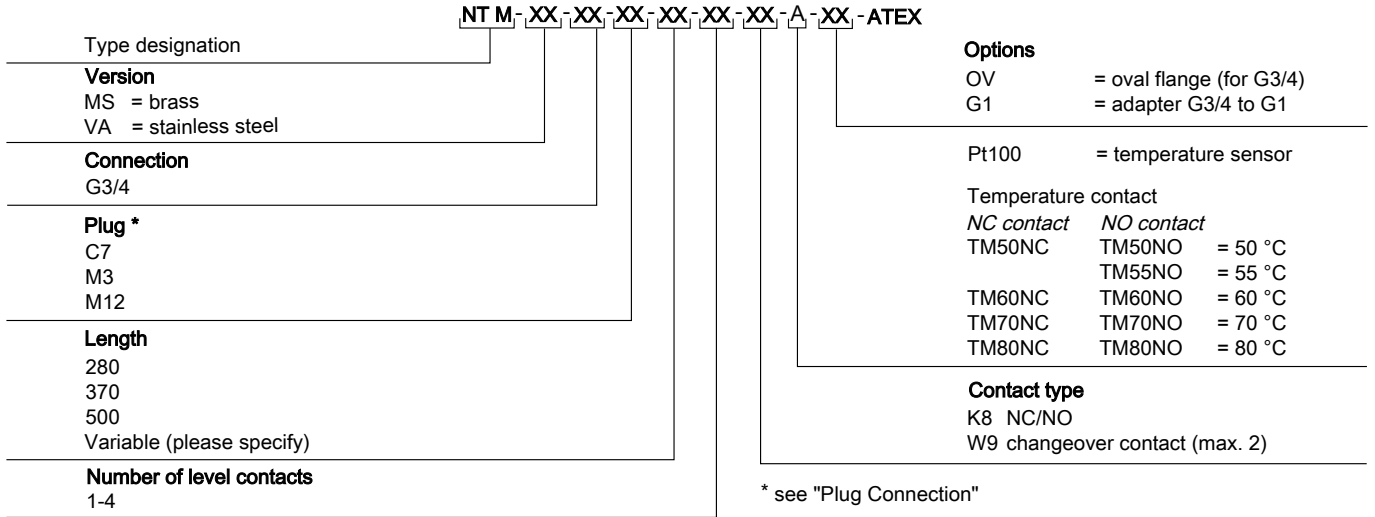

2 Safety instructions

2.1 Important advice

This unit may only be used if:

- The product is being used under the conditions described in the operating- and system instructions, used according to the nameplate and for applications for which it is intended. Any unauthorized modifications of the device will void the warranty provided by Bühler Technologies GmbH,
- The specifications and markings in the type plate are observed,
- The specified limits are observed,
- The equipment is operated on intrinsically-safe circuits, see chapter “Intrinsically-Safe Connection”,
- The protective element is installed outside the explosive area,
- No equipment functions exceed the limits,
- Monitoring equipment / protection devices are connected correctly,
- Service and repair work not described in these instructions are performed by Bühler Technologies GmbH,
- Genuine replacement parts are used.

Regulations EN 60079-14 and EN 60079-17 must be observed when erecting electrical systems in explosive areas.

Additional national regulations pertaining to initial operation, operation, maintenance, repairs and disposal must be observed.

These operating instructions are a part of the equipment. The manufacturer reserves the right to change performance-, specification- or technical data without prior notice. Please keep these instructions for future reference.

Signal words for warnings

DANGER	Signal word for an imminent danger with high risk, resulting in severe injuries or death if not avoided.
WARNING	Signal word for a hazardous situation with medium risk, possibly resulting in severe injuries or death if not avoided.
CAUTION	Signal word for a hazardous situation with low risk, resulting in damaged to the device or the property or minor or medium injuries if not avoided.
NOTICE	Signal word for important information to the product.

Warning signs

These instructions use the following warning signs:

	Warns of a general hazard		General information
	Warns not to inhale toxic gasses		Wear respiratory equipment
	Warns of corrosive liquids		Wear a safety mask
	Warns of explosive areas		Wear gloves



1800-OILSOL
1800-645765

<https://oilsolutions.com.au/>

sales@oilsolutions.com.au

2.2 General hazard warnings

The equipment must be installed by a professional familiar with the safety requirements and risks.

Be sure to observe the safety regulations and generally applicable rules of technology relevant for the installation site. Prevent malfunctions and avoid personal injuries and property damage.

The operator of the system must ensure:

- Safety notices and operating instructions are available and observed,
- The respective national accident prevention regulations are observed,
- The permissible data and operational conditions are maintained,
- Safety guards are used and mandatory maintenance is performed,
- Legal regulations are observed during disposal,
- compliance with national installation regulations.

Maintenance, Repair

Please note during maintenance and repairs:

- Repairs to the unit must be performed by Bühler authorised personnel.
- Only perform conversion-, maintenance or installation work described in these operating and installation instructions.
- Always use genuine spare parts.
- Do not install damaged or defective spare part. If necessary, visually inspect prior to installation to determine any obvious damage to the spare parts.

Always observe the applicable safety and operating regulations in the respective country of use when performing any type of maintenance.

The method for cleaning the devices must be adapted to the IP protection class of the devices. Do not use cleaners which could damage the device materials.

DANGER



Toxic, acidic gases/liquids

Protect yourself from toxic, corrosive gasses/liquids when performing any type of work. Wear appropriate protective equipment.



3 Transport and storage

Only transport the product inside the original packaging or a suitable alternative.

The equipment must be protected from moisture and heat when not in use. It must be stored in a covered, dry, dust-free room at room temperature.



1800-OILSOL
1800-645765

<https://oilsolutions.com.au/>

sales@oilsolutions.com.au

4 Installation and connection

4.1 Installation

Please note before installing the level switch!

After transport and delivery of the level switch, the switching status of the bistable contacts may be different than required for proper operation.

Therefore slide the float for the level switch along the level switch tube from below immediately before installation.

This ensures all built-in bistable contacts have a clearly defined switching status (NC or NO).

The level switches (transmitters) come fully assembled and can be mounted to the tank via by screw-in thread and seal. Please be sure the float can move freely and to leave enough space between the tank wall and add-ons.

After removing the float, where applicable, be sure the magnet inside the float is above the fluid level. This can easily be verified with a piece of iron to determine the magnet position inside the float.

4.2 Electrical connections

Please refer to the tables in the appendix for the pin assignment and electrical data of your level switch.

Proceed as follows: Locate (as specified in your order) the plug type, the contact type (NC/NO or changeover contact, with or without temperature measurement) and the number of contacts.

Please note, every level switch must be connected to the earthed tank container using the existing external PA connection.

4.2.1 PA connection (potential equalisation)

CAUTION

Electrostatic charge



Level switch housings must be connected to the tank via external PA connection! Ensure the level switch is adequately earthed (minimum conductor cross-section 4 mm²). Please also particularly observe the requirements of EN 60079-14.



The level switch has an external PA connection. This is identified by the decal shown on the right. The connection uses an M4 thread. The PA cable for potential equalisation between the level switch and the tank is not included and must be supplied and installed by the customer.

Layout of the PA connection:

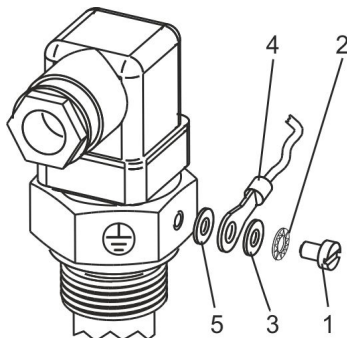

1 Screw	4 PA cable (to be installed by the customer)
2 Serrated washer	5 Washer
3 Washer	

PA connection example:

Drawing A

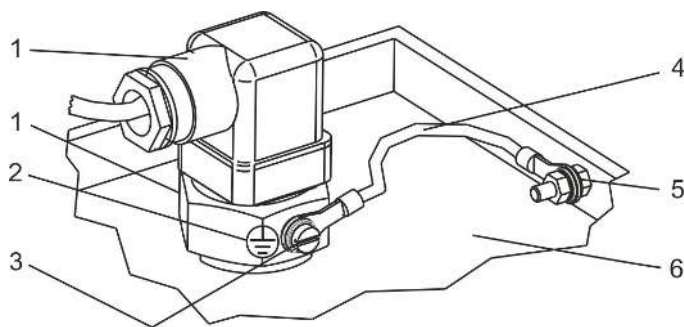

1 NT-M ATEX level switch	5 PA cable
2 PA decal	6 PA connection on the tank
3 PA connection on the level switch	7 Tank

4.2.2 Intrinsically-safe connection

According to EN 60079-11 the components for level and temperature monitoring are simple electrical equipment and to be considered purely ohmic circuits. The electrical circuits must be operated separately using a controller suitable for the zone; please note the information specified in the pin assignments.

CAUTION

Explosion hazard due to prohibited electrical connection data



Prohibited electrical connection data can cause an explosive gas mixture to ignite. In areas with explosive gas atmospheres the level switch may only be operated with an intrinsically-safe power supply. The power supply must be suitable for the respective zone. The limits specified in these operating instructions must be observed and must not exceeded, even with two separate intrinsically-safe power supplies. Ensure the limits will not be exceeded, even in the event of a fault, e.g. accidental series or parallel connection. Please observe the relevant safety requirements, e.g. EN 60079-11 and EN 60079-14, when installing and operating intrinsically-safe equipment.

Please refer to the chart below for the technical parameters and the approved limits (U_i , I_i , C_i , L_i , P_i) for intrinsically-safe operation:

	U_i	I_i	C_i	L_i	P_i
Level contact	30 V	50 mA	negligible	negligible	100 mW
Temperature contact	30 V	50 mA	negligible	negligible	100 mW
Pt100 Temperature Sensor	30 V	50 mA	negligible	negligible	100 mW

Remarks about the Pt100 connection

Operate the Pt100 with the respective EX approved RTD converter or a separating barrier with RTD input, suitable for EX. The measuring current must be $\leq 1 \text{ mA}$ to prevent excessive self-heating, which will cause measuring errors.



1800-OILSOL
1800-645765

<https://oilsolutions.com.au/>

sales@oilsolutions.com.au

5 Operation and control

DANGER



Toxic, acidic gases/liquids

Protect yourself from toxic, corrosive gasses/liquids when performing any type of work. Wear appropriate protective equipment.



DANGER



Dangerous electrostatic charge (explosion hazard)

The equipment may only be used where normal operating conditions do not produce frequent flammable, electrostatic discharge.

Sparking

Incendive electrostatic charges may occur when cleaning plastic housing parts and decals (e.g. with a dry cloth or compressed air). The sparks this produces could ignite flammable, explosive atmospheres.

Always clean plastic housing parts and decals **with a damp cloth!**

DANGER



Impact

Strong blows to the housing can produce sparks, which can ignite an EX atmosphere. Protect the equipment from external impact. Damaged housing parts must be replaced immediately.

CAUTION



Explosion hazard due to prohibited electrical connection data

Prohibited electrical connection data can cause an explosive gas mixture to ignite. In areas with explosive gas atmospheres the level switch may only be operated with an intrinsically-safe power supply. The power supply must be suitable for the respective zone. The limits specified in these operating instructions must be observed and must not exceeded, even with two separate intrinsically-safe power supplies.

Ensure the limits will not be exceeded, even in the event of a fault, e.g. accidental series or parallel connection.

Please observe the relevant safety requirements, e.g. EN 60079-11 and EN 60079-14, when installing and operating intrinsically-safe equipment.

NOTICE



The device must not be operated beyond its specifications.

Before startup, check

- the electrical connections are undamaged and correctly installed,
- the level switch is connected intrinsically-safe (proof of intrinsic safety e.g. according to EN 60079-14),
- no parts have been removed from the level switches,
- protection and monitoring devices are installed and functional (e.g. switch amplifier),
- the ambient parameters and technical specifications (e.g. U, I) are met,
- electrical connections are securely connected and the monitoring devices are connected and set as prescribed.
- Precautions have been taken,
- the screws are installed with gaskets,
- the connectors are closed and the cable glands are properly sealed.
- The requirements of EN 60079-14 are met,
- the earth is proper and functional.

Level display:

Inside the float of a level switch is a magnet which is mounted in a way that exceeding the level contacts (bistable reed contacts) will trigger these magnetically. This can switch signals used to display the liquid level. When using several level contacts inside the level switch, signals are switched using a common root.

Temperature monitoring:

The temperature of a fluid is monitored via bimetal disc thermostat inside the level switch tube. When a set temperature is reached, a bimetal snap disk inside the thermostat is triggered, which opens or closes an electrical contact. A Pt100 temperature sensor can optionally be used in place of the bimetal thermostat.

Please note the technical specifications for the level switches and the connection diagrams at the end of this manual.



1800-OILSOL
1800-645765

<https://oilsolutions.com.au/>

sales@oilsolutions.com.au

6 Cleaning and Maintenance

This device is maintenance-free.

The method for cleaning the devices must be adapted to the IP protection class of the devices. Do not use cleaners which could damage the device materials.



1800-OILSOL
1800-645765

<https://oilsolutions.com.au/>

sales@oilsolutions.com.au

7 Service and repair

This chapter contains information on troubleshooting and correction should an error occur during operation.

Repairs to the unit must be performed by Bühler authorised personnel.

Please contact our Service Department with any questions:

Tel.: +49-(0)2102-498955 or your agent

If the equipment is not functioning properly after correcting any malfunctions and switching on the power, it must be inspected by the manufacturer. Please send the equipment inside suitable packaging to:

Bühler Technologies GmbH

- Reparatur/Service -

Harkortstraße 29

40880 Ratingen

Germany

Please also attach the completed and signed RMA decontamination statement to the packaging. We will otherwise be unable to process your repair order.

You will find the form in the appendix of these instructions, or simply request it by e-mail:

service@buehler-technologies.com.



1800-OILSOL
1800-645765

<https://oilsolutions.com.au/>

sales@oilsolutions.com.au

8 Disposal

Dispose of parts so as not to endanger the health or environment. Follow the laws in the country of use for disposing of electronic components and devices during disposal.



1800-OILSOL
1800-645765

<https://oilsolutions.com.au/>

sales@oilsolutions.com.au

9 Appendices

9.1 Technical Data

NT M...-Atex

Operating pressure:	max. 1 bar	
Medium /operating temperature:	max. +80 °C (C7 and M3 plug) max. +70 °C (M12 plug)	
Ambient temperature:	-20 to +80 °C (C7 and M3 plug) -20 to +70 °C (M12 plug)	
Fluid density:	min. 0.8 kg/dm ³	
Material	MS	VA
Switching tube:	Brass	1.4571
Flange:	Brass	1.4571
Float SK 161	NBR	NBR
Level contacts	K8	W9
Function	NC/NO*	Changeover contact
Min. contact spacing	40 mm	40 mm
Temperature contacts		
Switch-back difference:	15 K ± 5 K	
Switching point:		
		NC* NO*
	50 °C	TMÖ-50 -
	55 °C	- TMS-55
	60 °C	TMÖ-60 TMS-60
	70 °C	TMÖ-70 TMS-70
	80 °C	TMÖ-80 TMS-80

Other temperatures available upon request

*NC = NC contact/NO = NO contact All data for rising temperature

Pt100 resistance thermometer

(Pt100 class B DIN / IEC 751)

Tolerance:	± 0.8 K
Measuring current I_c :	≤ 1 mA
P_i :	100 mW
U_i :	30 V
I_i :	50 mA
L_i, C_i :	negligible

Accessories

Connection cable M12x1 (5-pin) 3.0 m long, item no.: 9144050018

Adapter G3/4 to G1, item no.: 1011000

Adapter G3/4 to oval flange, item no.: 1012000

The device is suitable for use in ATEX category II 3 G Ex ic IIC T4 Gc.

The level switches may only be operated on intrinsically-safe circuits!

Temperature contacts

P_i	100 mW
U_i	30 V
I_i	50 mA
$L_i; C_i$	Negligible

Dimensions

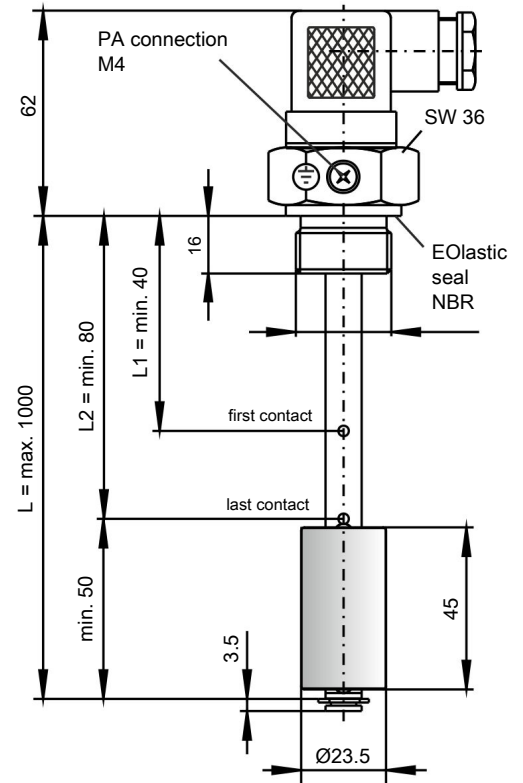

9.2 Standard pin assignment

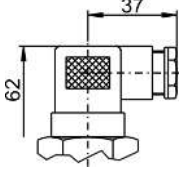
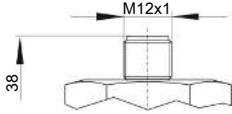
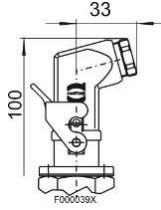
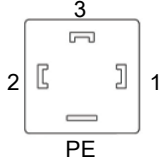
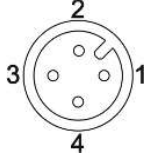
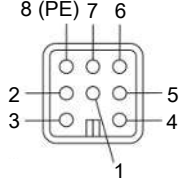
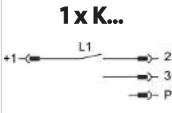
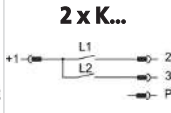
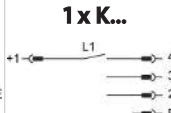
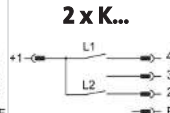
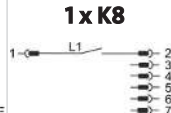
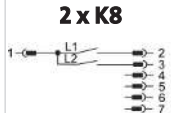
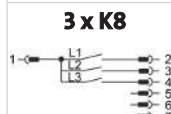
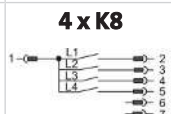
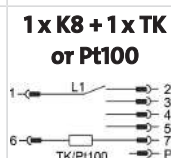
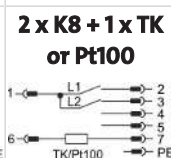
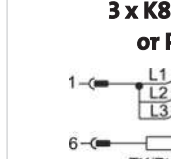
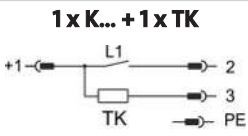
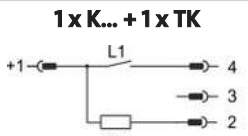
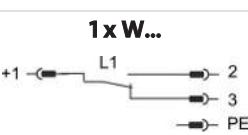
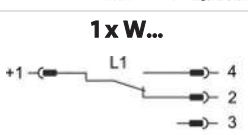
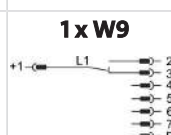
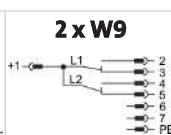
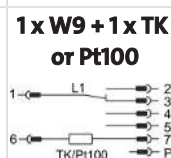
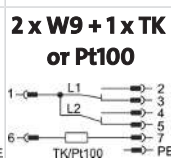
Connector:	M3 valve connector	M12 plug A coded	C7 HAN 3 A
Dimensions:			
Connection schematic:			
Number of poles:	3-pin + PE	4-pin + PE	7-pin + PE
DIN EN	175301-803	61076-2-101	175301-801
Max. operating voltage:	30 V DC	30 V DC	30 V DC
IP rating:	IP65	IP67*	IP65**
Cable fitting:	PG 11		PG11
Only level contact(s) Type K8 (NC/NO)	<p>1 x K...</p>  <p>2 x K...</p> 	<p>1 x K...</p>  <p>2 x K...</p> 	<p>1 x K8</p>  <p>2 x K8</p>  <p>3 x K8</p>  <p>4 x K8</p> 
Level contact(s) Type K8 (NC/NO) plus temperature contact TK or Pt100 Attention: 2 separate roots			<p>1 x K8 + 1 x TK or Pt100</p>  <p>2 x K8 + 1 x TK or Pt100</p>  <p>3 x K8 + 1 x TK or Pt100</p> 
Level contact(s) type K8 or K10 (NC/NO) plus temperature contact TK	<p>1 x K... + 1 x TK</p> 	<p>1 x K... + 1 x TK</p> 	
Only level contact(s) Type W9 (changeover contact)	<p>1 x W...</p> 	<p>1 x W...</p> 	<p>1 x W9</p>  <p>2 x W9</p> 
Only level contact(s) Type W9 (change-over contact) plus temperature contact TK or Pt100 Attention: 2 separate roots			<p>1 x W9 + 1 x TK or Pt100</p>  <p>2 x W9 + 1 x TK or Pt100</p> 

*with respective plug top.

**IP 44 with gland/without gasket.

9.3 Definitions

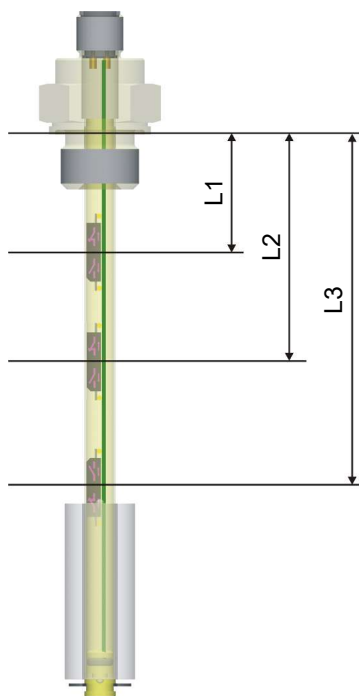

The contact positions are measured top to bottom:

L1 = Contact no. 1

L2 = Contact no. 2

L3 = Contact no. 3

, etc.

Note: The number of contacts may be limited depending on the level switch model (see model key in the type plate and technical data).

Abbreviation	Explanation
NO	rising NO contact/falling NC contact
NC	rising NC contact/falling NO contact
TK	Temperature contact
PT	Pt100 Temperature Sensor
L1, L2, L3, L4	Level contact
T1, T2, T3, T4	Temperature output/contact

10 Attached documents

- Manufacturer Declaration HX100001
- RMA - Decontamination Statement



1800-OILSOL
1800-645765

<https://oilsolutions.com.au/>

sales@oilsolutions.com.au

Herstellereklärung Manufacturer Declaration



der Firma Bühler Technologies GmbH nach
EN 60079-11 Abschn. 5.7 „Einfache elektrische
Betriebsmittel“.

by Bühler Technologies GmbH pursuant to
EN 60079-11 Section 5.7 "Simple apparatus".

Produkt / products: Niveauschalter für Tankeinbau / level switch for top tank installation
Typ / type: NT M...-Atex

Zusätzliche Angaben/additional details:

Die Erklärung gilt für alle Exemplare, die nach den beim Hersteller hinterlegten Fertigungsunterlagen – die Bestandteil dieser Erklärung sind - hergestellt wurden.

Bei dem Betriebsmittel handelt es sich nach EN 60079-11 um ein einfaches elektrisches Betriebsmittel ohne eigene Zündquelle, welches für den Tankeinbau bestimmt ist. Gemäß den Anforderungen dieser Norm wird dieses Betriebsmittel keiner Typprüfung und keiner Kennzeichnung nach Richtlinie **2014/34/EU (Atex)** unterworfen.

Bei eigensicherem Anschluss kann das Betriebsmittel im explosionsgefährdeten Bereich der Zone 2 (Gruppe IIC) installiert werden. Eine vergleichbare ATEX-Kennzeichnung lautet: II 3G Ex ic IIC T4 Gc.

Die Betriebsmittel dürfen nur durch Fachpersonal installiert werden; die einschlägigen Sicherheitsvorschriften (z.B. EN 60079-14) sind zwingend zu beachten.

This declaration is valid for all devices manufactured according to the design and manufacturing specifications of the manufacturer. These specifications are part of this declaration.

*According to EN 60079-11, the equipment is a simple electrical apparatus without innate ignition source intended for tank top installation. According to this standard this equipment is not subject to type approval and marking pursuant to directive **2014/34/EC (Atex)**.*

In case of intrinsically safe connection they can be used in Zone 2 (group IIC) of Ex-areas. A comparable ATEX marking is: II 3G Ex ic IIC T4 Gc.

The equipment has to be installed by trained personnel. All safety regulations have to be fulfilled (e.g. EN 60079-14).

Beschaltungswerte der einfachen elektrischen Betriebsmittel/Parameters of the simple apparatuses:

$U_i = 30 \text{ V}$

$I_i = 50 \text{ mA}$

C_i, L_i vernachlässigbar/negligible

Messtrom/Measuring current (Pt100) $\leq 1 \text{ mA}$

Zur Beurteilung der Konformität gemäß Atex-Richtlinie wurden folgende harmonisierte Normen herangezogen:
For the assessment of conformity according to the Atex directive the following standards have been used:

EN 60079-11:2012

EN 60079-0:2012 + A11:2013

Die alleinige Verantwortung für die Ausstellung dieser Konformitätserklärung trägt der Hersteller.

This declaration of conformity is issued under the sole responsibility of the manufacturer.

Dokumentationsverantwortlicher für diese Konformitätserklärung ist Herr Stefan Eschweiler mit Anschrift am Firmensitz.

The person authorised to compile the technical file is Mr. Stefan Eschweiler located at the company's address.

Ratingen, den 05.09.2018

Stefan Eschweiler
Geschäftsführer – Managing Director

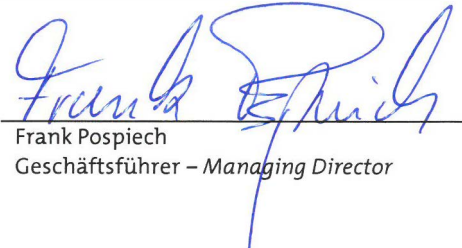
Frank Pospiech
Geschäftsführer – Managing Director

HX 10 0001

Bühler Technologies GmbH, Harkortstr. 29, D-40880 Ratingen,
Tel. +49 (0) 21 02 / 49 89-0, Fax. +49 (0) 21 02 / 49 89-20
Internet: www.buehler-technologies.com



1800-OILSOL
1800-645765

<https://oilsolutions.com.au/>

sales@oilsolutions.com.au

RMA-Formular und Erklärung über Dekontaminierung

RMA-Form and explanation for decontamination



RMA-Nr./ RMA-No.

Die RMA-Nummer bekommen Sie von Ihrem Ansprechpartner im Vertrieb oder Service./ You may obtain the RMA number from your sales or service representative.

Zu diesem Rücksendeschein gehört eine Dekontaminierungserklärung. Die gesetzlichen Vorschriften schreiben vor, dass Sie uns diese Dekontaminierungserklärung ausgefüllt und unterschrieben zurücksenden müssen. Bitte füllen Sie auch diese im Sinne der Gesundheit unserer Mitarbeiter vollständig aus./ This return form includes a decontamination statement. The law requires you to submit this completed and signed decontamination statement to us. Please complete the entire form, also in the interest of our employee health.

Firma/ Company

Firma/ Company
Straße/ Street
PLZ, Ort/ Zip, City
Land/ Country

Ansprechpartner/ Person in charge

Name/ Name
Abt./ Dept.
Tel./ Phone
E-Mail
Serien-Nr./ Serial No.
Artikel-Nr./ Item No.

Gerät/ Device
Anzahl/ Quantity
Auftragsnr./ Order No.

Grund der Rücksendung/ Reason for return

- Kalibrierung/ Calibration Modifikation/ Modification
 Reklamation/ Claim Reparatur/ Repair
 andere/ other

bitte spezifizieren/ please specify

Ist das Gerät möglicherweise kontaminiert?/ Could the equipment be contaminated?

- Nein, da das Gerät nicht mit gesundheitsgefährdenden Stoffen betrieben wurde./ No, because the device was not operated with hazardous substances.
 Nein, da das Gerät ordnungsgemäß gereinigt und dekontaminiert wurde./ No, because the device has been properly cleaned and decontaminated.
 Ja, kontaminiert mit:/ Yes, contaminated with:



explosiv/
explosive



entzündlich/
flammable



brandfördernd/
oxidizing



komprimierte
Gase/
compressed
gases



ätzend/
caustic



giftig,
Lebensgefahr/
poisonous, risk
of death



gesundheitsge-
fährdend/
harmful to
health



gesund-
heitsschädlich/
health hazard



umweltge-
fährdend/
environmental
hazard

Bitte Sicherheitsdatenblatt beilegen!/ Please enclose safety data sheet!

Das Gerät wurde gespült mit:/ The equipment was purged with:

Diese Erklärung wurde korrekt und vollständig ausgefüllt und von einer dazu befugten Person unterschrieben. Der Versand der (dekontaminierten) Geräte und Komponenten erfolgt gemäß den gesetzlichen Bestimmungen.

This declaration has been filled out correctly and completely, and signed by an authorized person. The dispatch of the (decontaminated) devices and components takes place according to the legal regulations.

Falls die Ware nicht gereinigt, also kontaminiert bei uns eintrifft, muss die Firma Bühler sich vorbehalten, diese durch einen externen Dienstleister reinigen zu lassen und Ihnen dies in Rechnung zu stellen.

Should the goods not arrive clean, but contaminated, Bühler reserves the right, to commission an external service provider to clean the goods and invoice it to your account.

Firmenstempel/ Company Sign

Datum/ Date

Bühler Technologies GmbH, Harkortstr. 29, D-40880 Ratingen
Tel. +49 (0) 21 02 / 49 89-0, Fax: +49 (0) 21 02 / 49 89-20
E-Mail: service@buehler-technologies.com
Internet: www.buehler-technologies.com

rechtsverbindliche Unterschrift/ Legally binding signature

DE000011
01/2019



1800-OILSOL
1800-645765

<https://oilsolutions.com.au/>

sales@oilsolutions.com.au



Die Analyse defekter Baugruppen ist ein wesentlicher Bestandteil der Qualitätssicherung der Firma Bühler Technologies.

Um eine aussagekräftige Analyse zu gewährleisten muss die Ware möglichst unverändert untersucht werden. Es dürfen keine Veränderungen oder weitere Beschädigungen auftreten, die Ursachen verdecken oder eine Analyse unmöglich machen.

Bei elektronischen Baugruppen kann es sich um elektrostatisch sensible Baugruppen handeln. Es ist darauf zu achten, diese Baugruppen ESD-gerecht zu behandeln. Nach Möglichkeit sollten die Baugruppen an einem ESD-gerechten Arbeitsplatz getauscht werden. Ist dies nicht möglich sollten ESD-gerechte Maßnahmen beim Austausch getroffen werden. Der Transport darf nur in ESD-gerechten Behältnissen durchgeführt werden. Die Verpackung der Baugruppen muss ESD-konform sein. Verwenden Sie nach Möglichkeit die Verpackung des Ersatzteils oder wählen Sie selber eine ESD-gerechte Verpackung.

Beachten Sie beim Einbau des Ersatzteils die gleichen Vorgaben wie oben beschrieben. Achten Sie auf die ordnungsgemäße Montage des Bauteils und aller Komponenten. Versetzen Sie vor der Inbetriebnahme die Verkabelung wieder in den ursprünglichen Zustand. Fragen Sie im Zweifel beim Hersteller nach weiteren Informationen.

Analysing defective assemblies is an essential part of quality assurance at Bühler Technologies.

To ensure conclusive analysis the goods must be inspected unaltered, if possible. Modifications or other damages which may hide the cause or render it impossible to analyse are prohibited.

Electronic assemblies may be sensitive to static electricity. Be sure to handle these assemblies in an ESD-safe manner. Where possible, the assemblies should be replaced in an ESD-safe location. If unable to do so, take ESD-safe precautions when replacing these. Must be transported in ESD-safe containers. The packaging of the assemblies must be ESD-safe. If possible, use the packaging of the spare part or use ESD-safe packaging.

Observe the above specifications when installing the spare part. Ensure the part and all components are properly installed. Return the cables to the original state before putting into service. When in doubt, contact the manufacturer for additional information.



1800-OILSOL
1800-645765

<https://oilsolutions.com.au/>

sales@oilsolutions.com.au

