



Oil/air cooler BLK

Drives and hydraulic aggregates are used in machine construction, raw material production, maritime and many other areas.

In hydraulic systems oil transfers power and motion, in drives it's a vital lubricant. Both as a power transfer medium and lubricant oil is heated by friction losses during operation.

Since the viscosity of the oil changes along with the temperature, precise temperature stabilisation using coolers is a vital requirement for systems and drives for consistent power. The temperature further affects the ageing behaviour and the life of oils.

Due to the unlimited supply, ambient air as the coolant for heat dissipation. However, since the air temperature fluctuates throughout the year and oil flow can also fluctuate, the heat exchanger required to stabilise the oil temperature must be carefully configured.

The BLK series features efficient cooling matrixes, an easy to maintain design and energy-efficient fan motors.

Easy to maintain design

Compact installation dimensions

Low noise emission

Broad performance range

Rugged cooling matrix

Extensive accessories



1800-OILSOL
1800-645765

<https://oilsolutions.com.au/>

sales@oilsolutions.com.au



Introduction and description

Why coolers?

There are basically two main concepts in the development of fluid power systems.

One is to design systems without using a cooler, and if operational conditions show that the system needs a cooler, install it later at additional costs. This understandably then often calls for compromises, making the system more expensive.

The other concept recognizes that a system originally designed with an integrated cooler needs less installation space and is a better choice with respect to construction and system costs.

Why Bühler?

If an oil/air cooler is planned for cooling it needs to have a simple and compact design, noise emission be low, and be easy and quick to maintain.

When we developed the BLK series, we incorporated our years of experience in designing and selling oil/air coolers. Especially the fatigue life of the cooling matrix was a focus during development, since in some cases the matrix has to withstand considerable pressure peaks in the return line.

The cooling matrix can easily be removed from the fan case for maintenance without uninstalling the fan or motor.

If our comprehensive standard range of products does not include the right solution for your application, we will gladly develop a custom solution for you.

Use the data in this leaflet to determine a suitable cooler for your application.

Construction and application

The BLK series consist of the following components:

- Cooling matrix
- Fan case with mounting rails
- Blower, consisting of AC motor, fan and protective/mounting grate
- The cooling matrix and fan can be removed from the fan case individually without having to uninstall other components

The BLK series cooling matrix are made from aluminum. The coolers are designed for use in hydraulic circuits - including return lines. They are not suitable for pure water.

We also offer cooling matrixes with bypass (see type code).

Depending on the application or system requirements, off line filtration is often required. In these cases we recommend combining them with an off line circuit. You will find suitable units in our BNK series. These units are also suitable for upgrading existing systems.

Planning information

Set-up

The cooler must be set up so as not to interfere with air supply and exhaust. The distance to air obstacles behind the cooler should be at least half the cooler height (Dimension B).

Ensure adequate ventilation. During set-up, avoid exiting hot air or noise emission causing problems.

If the ambient air is dirty, excess deposit on the cooling matrix must be expected. This will reduce the cooling capacity. In this case, particularly in the case of air loaded with oil mist, the air ducts must be cleaned regularly.

When set up outdoors, adequately protect the motor from the weather.

Ensure easy access for inspection and maintenance.

Mount

The coolers are secured to the mounting rails with four screws. Be sure the support structure is sized adequately. Install in any position.

Connecting the oil circuit

The connection between the system and the cooling matrix should be connected stress and vibration free, which can be achieved by using conduit.

Follow the pertinent safety regulations to prevent environmental damage due to possible oil leaks (e.g. collection pans).



Model key

BLK 4.6- IBx - T50

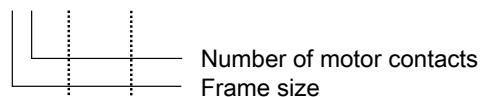

To also have a bypass and/or thermal contact, the specification will be added to the type designation:

Bypass version	AB (BLK 2-10)	external bypass
	IB (BLK 3-9)	internal bypass
	ITB (BLK 3-9)	internal temperature-dependent bypass 2 bar / 45 °C
	ATB (BLK 2-9)	external temperature-dependent bypass 2 bar / 45 °C
	x	bypass value 2 bar, 5 bar, 8 bar
Temperature switch	T50, T60 T70, T80	Temperature in °C, specification see separate data sheet

Technical data

Technical Data

Materials / surface protection

Cooling battery:	Aluminium, painted
ventilation box, safety guard and motor brackets:	Steel, powder-coated

Colour:	RAL 7001 / Motor: RAL 7024/7030
----------------	---------------------------------

Operating fluids:	Mineral oils according to DIN 51524 Gear lubricant according to DIN 51517-3 Oil/water emulsions HFA and HFB according to CETOP RP 77 H Water glycol HFC according to CETOP RF 77 H Phosphoric ester HFD-R according to CETOP RP 77 H
--------------------------	--

Operating pressure

static	
BLK 1.2:	max. 16 bar
BLK 2.2 – BLK 10.8:	max. 21 bar
dynamic	
BLK 1.2:	11 bar (at 5 M load cycle, 3 Hz)
BLK 2.2 – BLK 10.8:	15 bar (at 5 M load cycle, 3 Hz)
Operating oil temperature:	max. 80 °C (higher upon request)
Ambient temperature:	-15 to +40 °C

Electric motors (others available upon request)

Voltage / frequency:

BLK 1.2:	230 V - 50 Hz
BLK 2.2 – BLK 10.8:	220/380 – 245/420V 50Hz 220/380 – 280/480V 60Hz

Thermal stability:	Insulation class F, utilisation per Class B
---------------------------	--

Protection class:

BLK 1.2:	IP44
BLK 2.2 – BLK 10.8:	IP55

The motors comply with standards
IEC 60034, IEC 60072, IEC 60085



1800-OILSOL
1800-645765

<https://oilsolutions.com.au/>

sales@oilsolutions.com.au

Basic data (at 50 Hz frequency)

Item no.	Cooler type	Motor power Number of poles Rated current at 400 V	Weight (kg)	Capacity (L)	Noise level dB(A)*
3501200	BLK 1.2	0,05 kW / 2 / 0,24 A (230 V)	7	0,8	65
3502200IE3	BLK 2.2	0,55 kW / 2 / 1,3 A	25	1,3	81
3502400IE3	BLK 2.4	0,18 kW / 4 / 0,5 A	23	1,3	66
3503200IE3	BLK 3.2	1,1 kW / 2 / 2,3 A	34	1,8	87
3503400IE3	BLK 3.4	0,25 kW / 4 / 0,7 A	29	1,8	71
3504400IE3	BLK 4.4	0,37 kW / 4 / 1,0 A	33	2,3	73
3504600IE3	BLK 4.6	0,18 kW / 6 / 0,7 A	31	2,3	63
3505400IE3	BLK 5.4	0,75 kW / 4 / 1,9 A	48	3,1	79
3505600IE3	BLK 5.6	0,25 kW / 6 / 0,8 A	40	3,1	68
3506410IE3	BLK 6.4	2,2 kW / 4 / 4,6 A	77	4,1	86
3506610IE3	BLK 6.6	0,55 kW / 6 / 1,5 A	64	4,1	74
3507410IE3	BLK 7.4	2,2 kW / 4 / 4,6 A	88	5,4	89
3507610IE3	BLK 7.6	0,55 kW / 6 / 1,5 A	72	5,4	75
3508610IE3	BLK 8.6	1,5 kW / 6 / 3,8 A	104	6,3	79
3508810IE3	BLK 8.8	0,55 kW / 8 / 1,9 A	90	6,3	73
3509610IE3	BLK 9.6	2,2 kW / 6 / 5,6 A	158	8,2	86
3509810IE3	BLK 9.8	1,1 kW / 8 / 3,0 A	141	8,2	79
3510610IE3	BLK 10.6	5,5 kW / 6 / 12,8 A	258	19	90
3510810IE3	BLK 10.8	2,2 kW / 8 / 5,9 A	246	19	84

The item numbers for BLK 2.2-5.6 are 50/60 Hz versions, for BLK 6.4-10.8 only the 50 Hz version, please contact us for the 60 Hz version.

*DIN EN ISO 3744, Class 3

Calculation example and nomenclature

Determination

An oil/air cooler is determined in two steps:

1. Determining or selecting the cooler size
2. Determining the actual pressure loss

t_{OE} [°C]	Inlet oil temperature
t_{LE} [°C]	Inlet air temperature
ETD [K]	Temperature differential: $ETD = t_{OE} - t_{LE}$
P_{spez} [kW / K]	specific cooling performance (see performance curves): $P_{spez} = P / ETD$
P [kW]	Cooling performance in kW
Q [l/min]	Oil flow rate
C_{oil} [kJ/kgK]	Specific heat capacity of the oil (approx. 2.0 kJ / kgK)
ζ [kg/dm ³]	Gravity of oil ≈ 0.9 kg/dm ³

Calculation example

Assumptions:

Tank capacity	(V)	approx. 200 L
Start up temperature of oil	(T ₁)	15 °C (≈ 288 K)
Oil heats up in approx. t = 25 min. (1500 s) to	(T ₂)	45 °C (≈ 318 K)
Required oil temperature	(t _{OE})	60 °C
Inlet air temperature	(t _{LE})	30 °C



1800-OILSOL
1800-645765

<https://oilsolutions.com.au/>

sales@oilsolutions.com.au

Calculation

1. Calculating P from the tank warming

$$P = \frac{V \cdot \rho \cdot c_{Oil} (T_2 - T_1)}{t} = \frac{200 \text{ l} \cdot 0.9 \frac{\text{kg}}{\text{l}} \cdot 2 \frac{\text{kJ}}{\text{kg} \cdot \text{K}} \cdot (318 \text{ K} - 288 \text{ K})}{1500 \text{ s}} = 7.2 \text{ kW}$$

2. $ETD = t_{OE} - t_{LE} = 60 \text{ }^\circ\text{C} - 30 \text{ }^\circ\text{C} = 30 \text{ K}$
3. Determining the cooler size: $P_{spec} = P / ETD = 7.2 \text{ kW} / 30 \text{ K} = 0.24 \text{ kW/K}$
4. In the graph, select a cooler at 80 L/min with $P_{spec} 0.24 \text{ kW/K}$. There are two options: BLK 2.2 or the larger but quieter BLK 3.4

Pressure loss curves at medium viscosity of 30 cSt

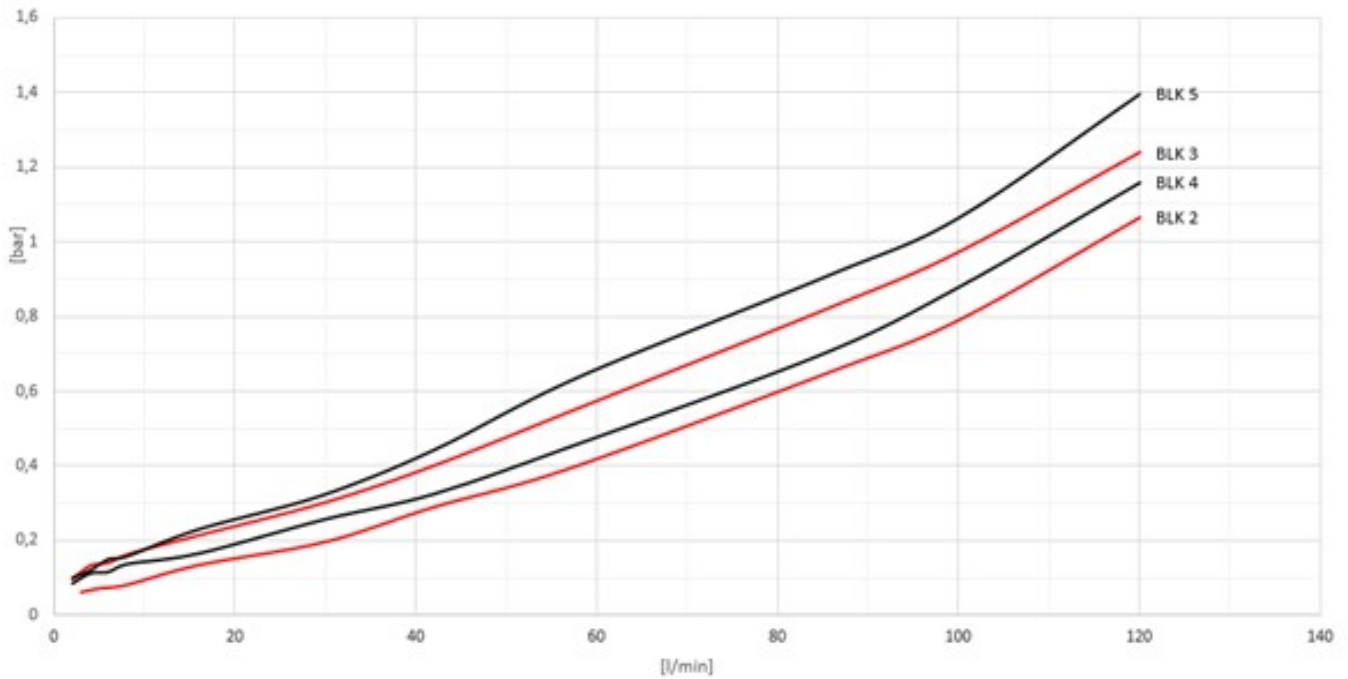

Fig. 1: Pressure loss curves BLK 2 to 5

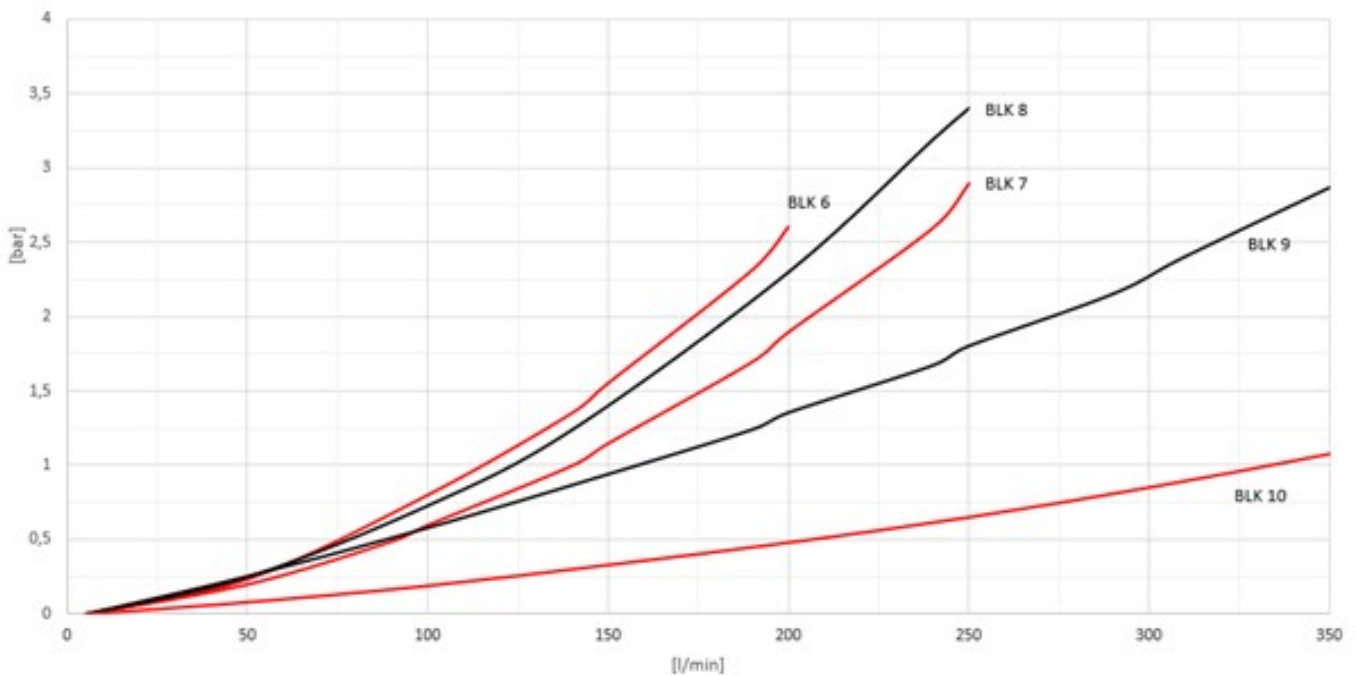

Fig. 2: Pressure loss curves BLK 6 to 10

Note: When installed outdoors or using higher viscosities, bypass valves may be required. Please note chapter Functional diagram.



1800-OILSOL
1800-645765

<https://oilsolutions.com.au/>

sales@oilsolutions.com.au

Temperature/viscosity table

Type of oil	at 50 °C	at 60 °C	at 70 °C
VG 16	9.4	5.6	3.3 cSt
VG 22	15	11	8 cSt
VG 32	21	15	11 cSt
VG 46	29	20	14 cSt
VG 68	43	29	20 cSt
VG 120	68	44	31 cSt
VG 220	126	77	51 cSt
VG 320	180	108	69 cSt

Correction k(visc)

Viscosity (cSt)	K(visc)	Viscosity (cSt)	K(visc)
10	0.6	60	1.6
20	0.8	80	2.1
30	1.0	100	2.7
40	1.2	150	4.2
50	1.4		

Determining the actual pressure loss

1. Determine Δp from the pressure loss graph for oil flow rate Q and the selected cooler size.
2. Determine the viscosity from the type of oil and temperature.
3. Determine the correction factor k(visc) and multiply by Δp from step 1.

Performance curves frame size 1-4

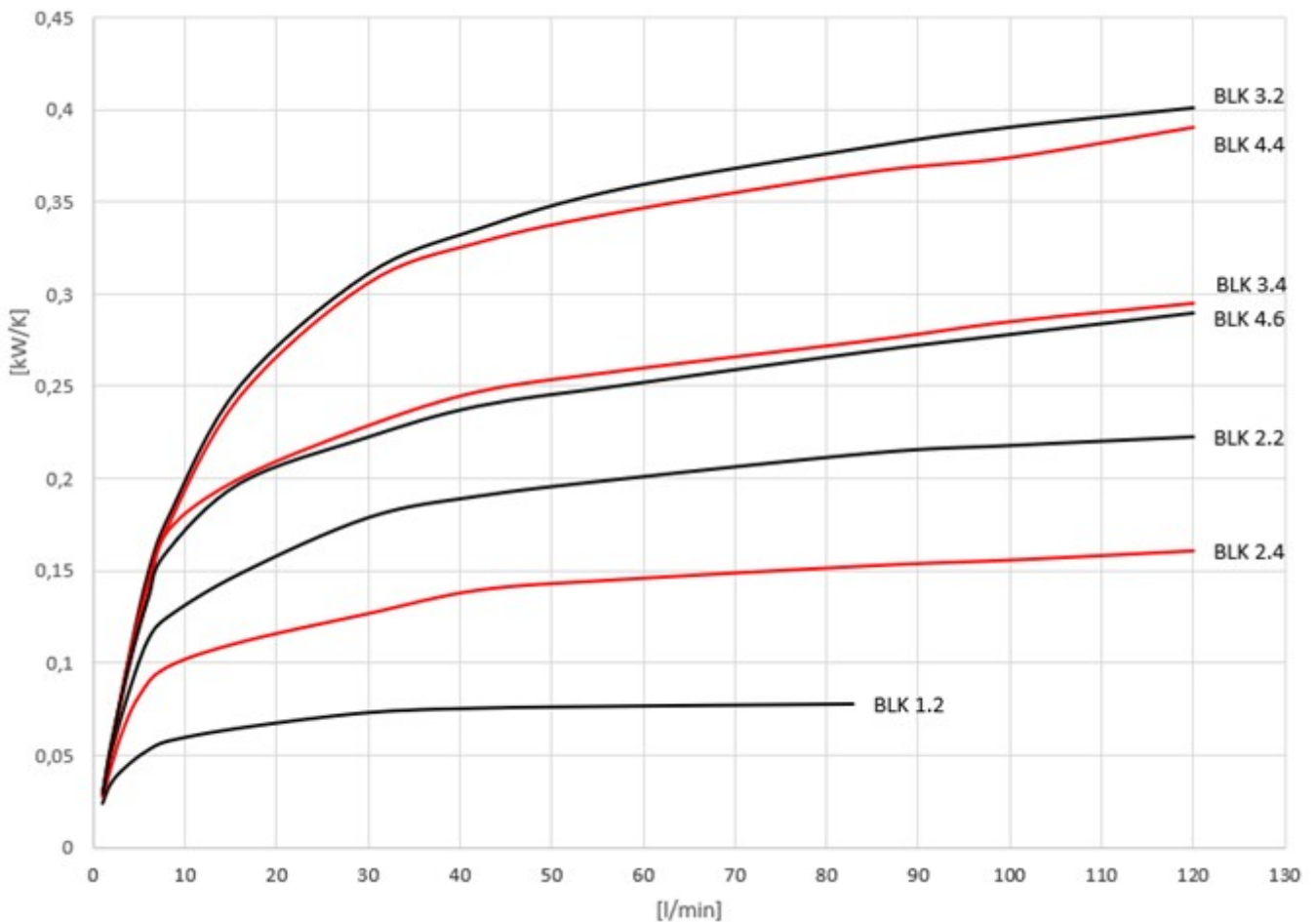

Performance curves frame size 5-7

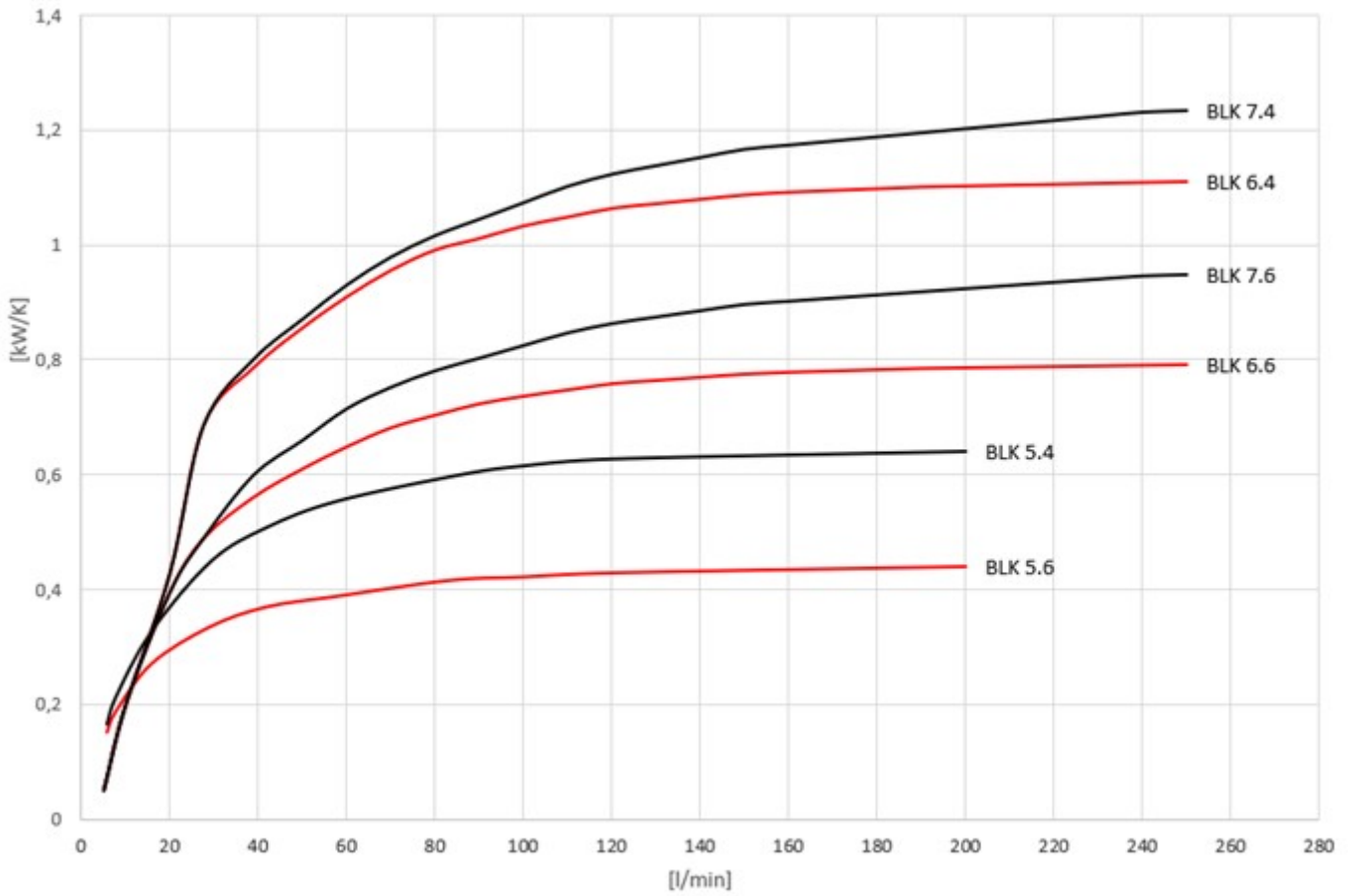

Performance curves frame size 8-10

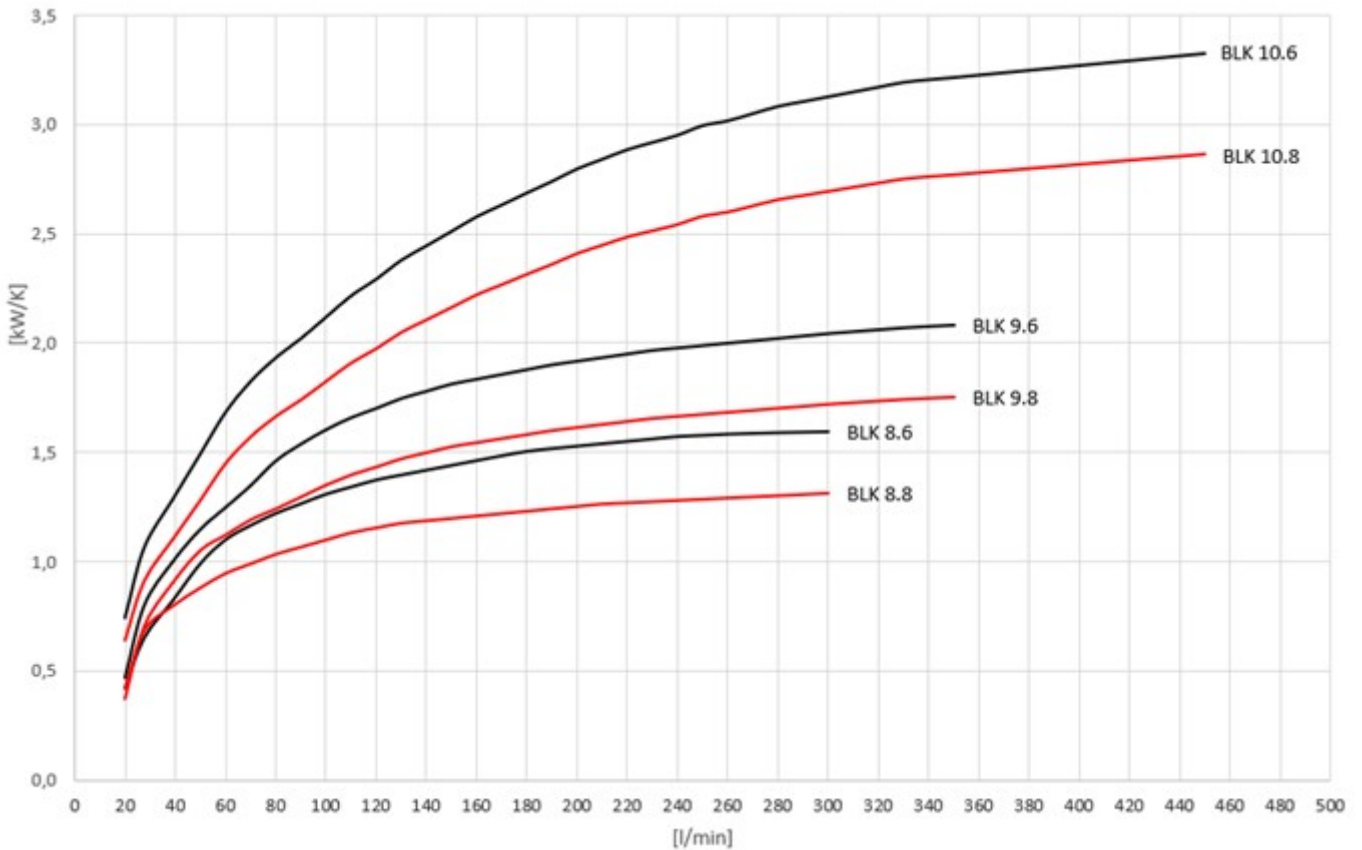

1800-OILSOL
1800-645765

<https://oilsolutions.com.au/>

sales@oilsolutions.com.au

Dimensions

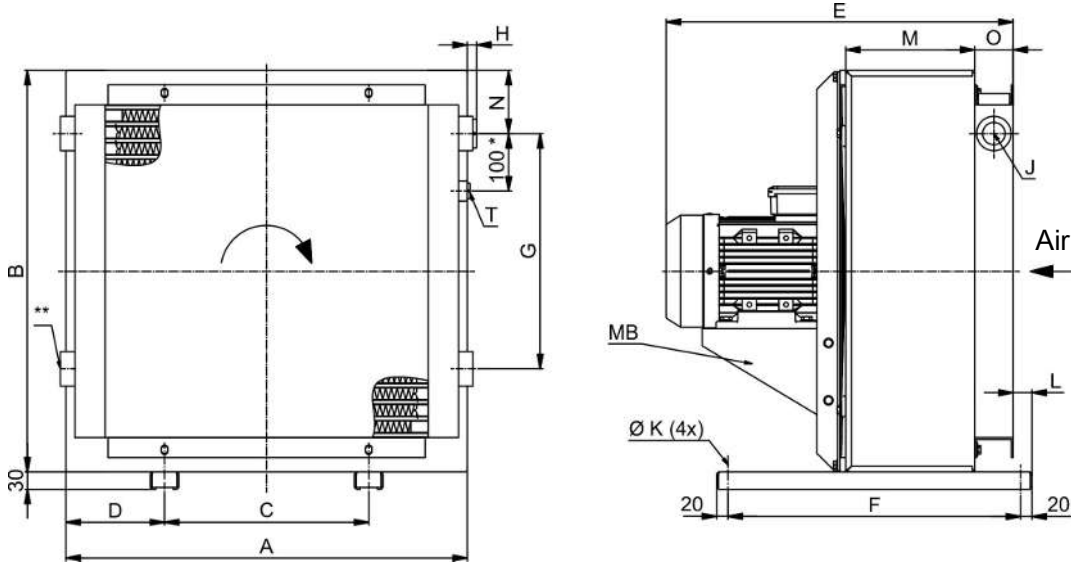

MB on some models the motors are mounted with a bracket
 * on BLK 9 and 10 = 150 mm
 ** Connection fitting on BLK 9 and 10 only

Model	A	B	C	D	E	F	G	H	J	K	L	M	N	O	MB
BLK 1.2	315	244	190	62,5	144	165	-	-	2x G1/2	7	20	50	33	45	-
BLK 2.2	370	370	203	83,5	416	510	-	25	2x G1	9	33	125	106	67	-
BLK 2.4	370	370	203	83,5	396	510	-	25	2x G1	9	33	125	106	67	-
BLK 3.2	440	440	203	118,5	464	510	230	25	3x G1	9	33	150	105	67	-
BLK 3.4	440	440	203	118,5	441	510	230	25	3x G1	9	33	150	105	67	-
BLK 4.4	500	500	203	148,5	466	510	230	25	3x G1	9	33	175	104	67	-
BLK 4.6	500	500	203	148,5	466	510	230	25	3x G1	9	33	175	104	67	-
BLK 5.4	580	580	356	112	514	510	305	23,5	3x G1	9	33	200	100	67	-
BLK 5.6	580	580	356	112	491	510	305	23,5	3x G1	9	33	200	100	67	-
BLK 6.4	700	700	356	172	612	510	410	9,5	3x G1 1/4	9	33	225	110	67	x
BLK 6.6	700	700	356	172	539	510	410	9,5	3x G1 1/4	9	33	225	110	67	x
BLK 7.4	700	840	356	172	637	510	590	9,5	3x G1 1/4	9	33	250	91	67	x
BLK 7.6	700	840	356	172	564	510	590	9,5	3x G1 1/4	9	33	250	91	67	x
BLK 8.6	870	870	508	181	651	510	585	11	3x G1 1/4	12	33	275	101,5	67	x
BLK 8.8	870	870	508	181	625	510	585	11	3x G1 1/4	12	33	275	101,5	67	x
BLK 9.6	1010	1020	518	246	714	890	822	3	4x G1 1/2	12	78	300	99	67	x
BLK 9.8	1010	1020	518	246	692	890	822	3	4x G1 1/2	12	73	300	99	67	x
BLK 10.6	1185	1185	600	292,5	852	910	940	5	4x SAE 2 1/2	12	73	325	130	94	x
BLK 10.8	1185	1185	600	292,5	815	910	940	5	4x SAE 2 1/2	12	73	325	130	94	x

BLK 1

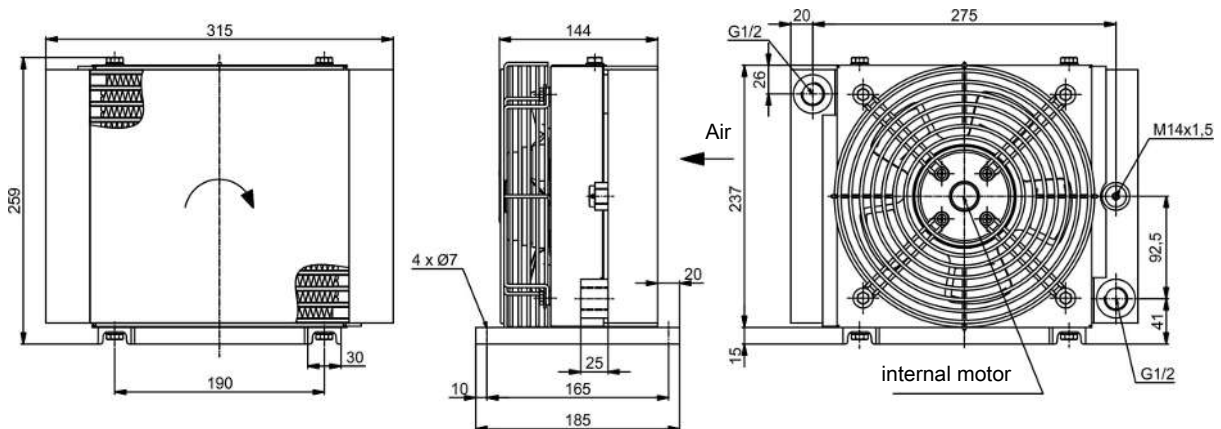

Functional diagram

Standard version BLK 2

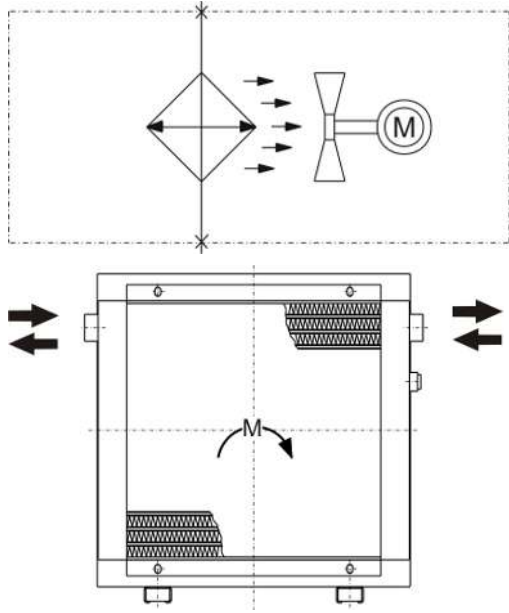

Direction of flow left to right or vice versa.

Standard version BLK 1, 3 to BLK 10

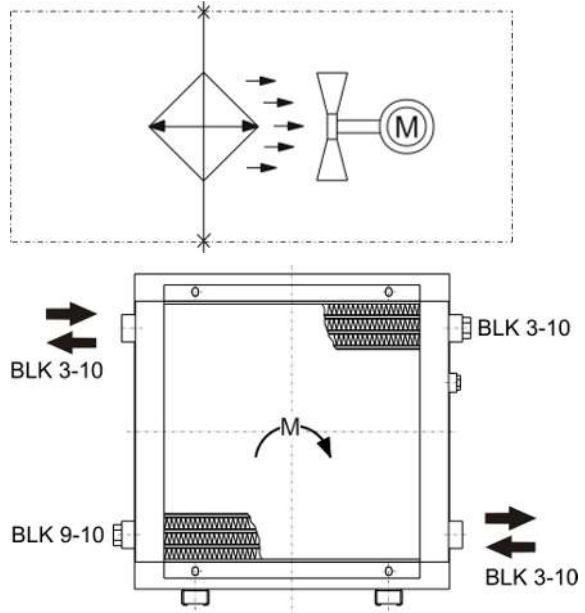

Direction of flow top left to bottom right or the exact opposite. The oil outlet is always on the opposite side. The second connection must be closed.

Internal bypass IB/ ITB (BLK 3-9)

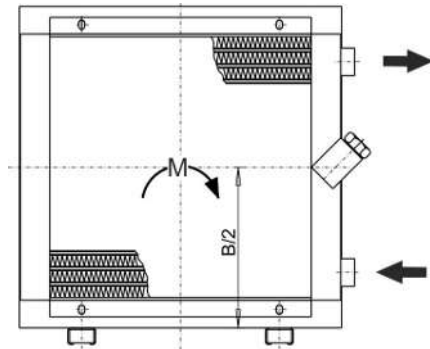

The oil inlet and outlet are always on the same side. Connections on the opposite side must be closed.

External bypass AB (BLK 2-10) / ATB (BLK 2-9)

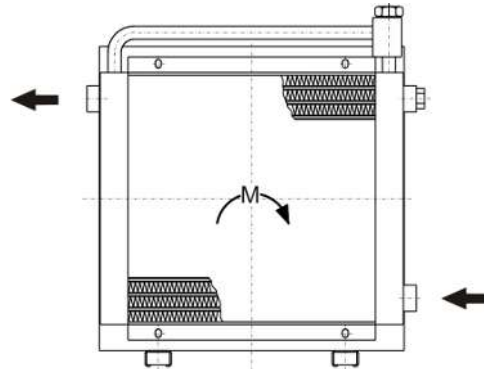

Oil inlet always at the bottom. Other connections must be closed. Oil outlet always on the opposite side.

With bypass valve

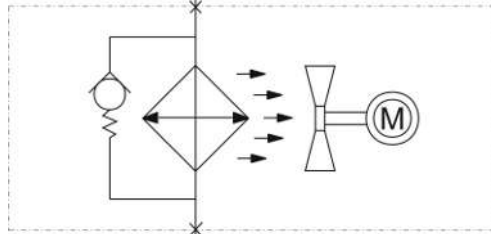

With temperature switch attached

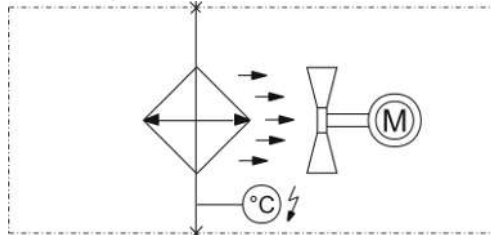

With temperature-dependent bypass valve

