



Heat exchangers

BWT

Installation and Operation Instructions

Original instructions



1800-OILSOL
1800-645765

<https://oilsolutions.com.au/>

sales@oilsolutions.com.au





Bühler Technologies GmbH, Harkortstr. 29, D-40880 Ratingen
Tel. +49 (0) 21 02 / 49 89-0, Fax: +49 (0) 21 02 / 49 89-20
Internet: www.buehler-technologies.com
E-Mail: fluidcontrol@buehler-technologies.com

Read this instruction carefully prior to installation and/or use. Pay attention particularly to all advises and safety instructions to prevent injuries. Bühler Technologies can not be held responsible for misusing the product or unreliable function due to unauthorised modifications.

All rights reserved. Bühler Technologies GmbH 2019

Document information

Document No.....BE340001
Version.....08/2019



1800-OILSOL
1800-645765

<https://oilsolutions.com.au/>

sales@oilsolutions.com.au

Contents

1	Introduction.....	2
1.1	Intended use	2
1.2	Scope of delivery.....	2
2	Safety instructions.....	3
2.1	Important advice.....	3
2.2	General hazard warnings	4
3	Transport and storage	5
4	Installation and connection	6
4.1	Installation site requirements.....	6
4.2	Installing the heat exchanger.....	6
5	Operation and control	7
5.1	During starting	7
5.2	Start-up the heat exchanger.....	7
5.3	Venting / Ventilation of the heat exchanger.....	7
5.4	Shut-down the heat exchanger	7
5.5	Impact of Water Quality on Corrosion Resistance	8
6	Maintenance.....	10
7	Service and repair.....	11
7.1	Troubleshooting	11
8	Disposal	12
9	Appendices.....	13
9.1	Technical data BWT	13
9.1.1	B05 / B08 / B15.....	13
9.1.2	B10 / B12 / B25	14
9.1.3	B35 / B120	15
9.1.4	B60	16
9.1.5	Mounting brackets.....	17
9.2	Technical data BWT-N.....	18
9.2.1	B05 / B08 / B15.....	18
9.2.2	B10 / B28.....	19
9.2.3	Mounting brackets.....	20
9.3	Technical Data BWT-DW	21
9.3.1	B16	21
9.3.2	Mounting bracket.....	21
9.4	Approvals	22
9.5	Calculations	22
9.5.1	Calculating viscosity	22
9.5.2	Table of operational viscosity for VG oil	22
9.5.3	Calculating the pressure loss	23
9.6	Pressure loss in straight pipes.....	23
10	Attached documents	25



1 Introduction

1.1 Intended use

BWT heat exchangers are suited for the cooling of oils in hydraulic and lubrication systems with water. Their scope is given by their specifications. The use in other applications is not permitted without confirmation by Bühler Technologies GmbH.

1.2 Scope of delivery

- 1 x Heat exchanger
- Product documentation



1800-OILSOL
1800-645765

<https://oilsolutions.com.au/>

sales@oilsolutions.com.au

2 Safety instructions

2.1 Important advice

Operation of the device is only valid if:

- the product is used under the conditions described in the installation- and operation instruction, the intended application according to the type plate and the intended use. In case of unauthorized modifications done by the user Bühler Technologies GmbH can not be held responsible for any damage,
- when complying with the specifications and markings on the nameplates.
- the performance limits given in the datasheets and in the installation- and operation instruction are obeyed,
- monitoring devices and safety devices are installed properly,
- service and repair is carried out by Bühler Technologies GmbH,
- only original spare parts are used.











This manual is part of the equipment. The manufacturer keeps the right to modify specifications without advanced notice. Keep this manual for later use.

Signal words for warnings

DANGER	Signal word for an imminent danger with high risk, resulting in severe injuries or death if not avoided.
WARNING	Signal word for a hazardous situation with medium risk, possibly resulting in severe injuries or death if not avoided.
CAUTION	Signal word for a hazardous situation with low risk, resulting in damaged to the device or the property or minor or medium injuries if not avoided.
NOTICE	Signal word for important information to the product.

Warning signs

In this manual, the following warning signs are used:

	Warning against hazardous situations		Warning against electrical voltage
	Warning against acid and corrosive substances		Warning against environmental hazard
	Warning against high pressure		General notice
	Warning against hot surface		Wear eye/face protection
	Warning against potentially explosive atmospheres		Wear protection gloves

2.2 General hazard warnings

The equipment must be installed by a professional familiar with the safety requirements and risks.

Be sure to observe the safety regulations and generally applicable rules of technology relevant for the installation site. Prevent malfunctions and avoid personal injuries and property damage.

The operator of the system must ensure:

- Safety notices and operating instructions are available and observed,
- The respective national accident prevention regulations are observed,
- The permissible data and operational conditions are maintained,
- Safety guards are used and mandatory maintenance is performed,
- Legal regulations are observed during disposal,
- compliance with national installation regulations.

Maintenance, Repair

Please note during maintenance and repairs:

- Repairs to the unit must be performed by Bühler authorised personnel.
- Only perform conversion-, maintenance or installation work described in these operating and installation instructions.
- Always use genuine spare parts.

Always observe the applicable safety and operating regulations in the respective country of use when performing any type of maintenance.

CAUTION



Hot surface

Burning hazard
Let the device cool down before maintaining.

CAUTION



High pressure

Hazard of injury due to flung off parts or oil, environmental hazard due to oil.

- a) Before starting any maintenance or repair to the oil circuit, make sure that the device is depressurized. This applies to the locking screws as well.
- b) Avoid environmental pollution (oil spills) during cleaning or maintenance of the oil circuit.
- c) Use drip pans.



WARNING



Voltage flashovers

Electrocution hazard

Do not earth the heat exchanger when carrying out welding work!

3 Transport and storage

The products should be transported only in its original packaging or a suitable replacement. Secure device for transportation. When not in use, protect the equipment against moisture and heat. Keep it in a covered, dry and dust-free room at ambient temperature.



1800-OILSOL
1800-645765

<https://oilsolutions.com.au/>

sales@oilsolutions.com.au

4 Installation and connection

4.1 Installation site requirements

Plate heat exchangers should be mounted leaving adequate clearance around each equipment for performing service work, etc. Install in any position. Only when used as an evaporator or capacitor require it to be installed vertically, any other installation position could result in decreased output.

4.2 Installing the heat exchanger

NOTICE



Piping must always be installed in such a way that no movement in the piping and no unadmissible forces are transferred to the plate heat exchanger!

CAUTION



Damages at the connection

Ensure no vibration is generated in the lines to prevent the plate heat exchanger connections from being damaged. Incorrect installation or operation could result in a defect of the welded joint at the connection, hence media mixing.

WARNING



Voltage flashovers

Electrocution hazard

Do not earth the heat exchanger when carrying out welding work!

The designation of the connections on the plate heat exchanger is indicated in the nameplate. Please refer to the decal for the connection position.

Soldered compact heat exchangers are connected parallel with counter flow. The circuits to be connected must be flushed prior to making the connection.

The piping to and from the plate heat exchanger must have shut-off valves. In addition, venting must be provided at the highest position in the upper connections, and drains in the lower connections.

When connection the plate heat exchanger, be sure the seals in the screw connections are clean.

5 Operation and control

NOTICE



The device must not be operated beyond its specifications.

CAUTION



Damages at the connection

Ensure no vibration is generated in the lines to prevent the plate heat exchanger connections from being damaged.
Incorrect installation or operation could result in a defect of the welded joint at the connection, hence media mixing.

5.1 During starting

Before operation it must be checked that the operating data **does not** exceed the data indicated on the marker's nameplate. Furthermore all bolted connections must be checked for tightness.

CAUTION



Hazard due to high pressure of the pump

Do not exceed the nominal pressure.
Install safety valves (pressure relief valves) to pumps that generate higher pressures.

The pumps feeding the plate heat exchanger must be equipped with control valves. Pumps which generate pressures higher than those specified for the unit must be equipped with safety valves. The water pump must not suction air to preclude operating faults through water hammers.

5.2 Start-up the heat exchanger

NOTICE



Pressure surges should be avoided!

To avoid hydraulic shocks the pumps should be started up against minimal opened valves. The valves in the supply and the return lines should be opened slowly, if possible simultaneously.

5.3 Venting / Ventilation of the heat exchanger

During the filling process the unit must be vented through the vent valves installed in the piping. Plate heat exchangers which are not vented to a sufficient degree do not achieve full performance because the heating surface is covered by air. Furthermore the corrosion risk increases when air remains in the unit.

5.4 Shut-down the heat exchanger

The two sides should be shut-down simultaneously and slowly. If this not possible the hot side should be shut down first.

If the cooler is shut down for a long time it should be drained completely and cleaned. This should be specially when there is a danger of frost and when aggressive media are involved.

5.5 Impact of Water Quality on Corrosion Resistance

The durability chart shown provides a greatly simplified overview of the corrosion resistance of stainless steels and soldering materials in tap water at room temperature.

- Explanations:**
- + Good resistance under normal conditions
 - 0 Corrosion may occur specifically if other factors are rated 0
 - Not recommended

WATER CONTENT	CONCENTRATION (mg/L or ppm)	TIME LIMIT Analyse before	AISI 304	AISI 316	254 SMO	COPPER	NICKEL
			Board material			Soldering material	
Alkalinity (HCO ₃ ⁻)	< 70	Within 24 h	+	+	+	0	+
	70-300		+	+	+	+	+
	> 300		+	+	+	0/+	+
Sulphate ^[1] (SO ₄ ²⁻)	< 70	No limit	+	+	+	+	+
	70-300		+	+	+	0/-	+
	> 300		+	+	+	-	+
HCO ₃ ⁻ / SO ₄ ²⁻	> 1.0	No limit	+	+	+	+	+
	< 1.0		+	+	+	0/-	+
Electric conductivity	< 10 µS/cm	No limit	+	+	+	0	+
	10-500 µS/cm		+	+	+	+	+
	> 500 µS/cm		+	+	+	0	+
pH ^[2]	< 6.0	Within 24 h	0	0	0	0	+
	6.0-7.5		+	+	+	0	+
	7.5-9.0		+	+	+	+	+
	> 9.0		+	+	+	0	+
Ammonium (NH ₄ ⁺)	< 2	Within 24 h	+	+	+	+	+
	2-20		+	+	+	0/-	+
	> 20		+	+	+	-	+
Chlorides (Cl ⁻) <i>also see table below</i>	< 100	No limit	+	+	+	+	+
	100-200		0	+	+	+	+
	200-300		-	+	+	+	+
	> 300		-	-	+	0/+	+
Chlorine gas (Cl ₂)	< 1	Within 5 h	+	+	+	+	+
	1-5		-	-	0	0	+
	> 5		-	-	-	0/-	+
Hydrogen sulphide (H ₂ S)	< 0.05	No limit		+	+	+	+
	> 0.05			+	+	0/-	+
Free (aggressive) carbon dioxide (CO ₂)	< 5	No limit	+	+	+	+	+
	5-20		+	+	+	0	+
	> 20		+	+	+	-	+
Total hardness (°dH)	4.0-8.5	No limit	+	+	+	+	+
Nitrate ^[1] (NO ₃ ⁻)	< 100	No limit	+	+	+	+	+
	> 100		+	+	+	0	+
Iron ^[3] (Fe)	< 0.2	No limit	+	+	+	+	+
	> 0.2		+	+	+	0	+
Aluminium (Al)	< 0.2	No limit	+	+	+	+	+
	> 0.2		+	+	+	0	+
Manganese ^[3] (Mn)	< 0.1	No limit	+	+	+	+	+
	> 0.1		+	+	+	0	+

^[1] Sulphates and nitrates act as inhibitors for pitting corrosion caused by chloride in pH-neutral environments.

^[2] A low pH value (below 6) generally increases the corrosion risk and a high pH value (over 7.5) reduces the corrosion risk.

^[3] Fe³⁺ and Mn⁴⁺ are strong oxidisers and can increase the risk of local corrosion in stainless steels.

SiO₂ over 150 ppm increase the calcification risk.



1800-OILSOL
1800-645765

<https://oilsolutions.com.au/>

sales@oilsolutions.com.au

CHLORIDE CONTENT	MAXIMUM TEMPERATURE			
	60 °C	80 °C	80 °C	80 °C
= 10 ppm	SS 304	SS 304	SS 304	SS 316
= 25 ppm	SS 304	SS 304	SS 316	SS 316
= 50 ppm	SS 304	SS 316	SS 316	Ti / 254 SMO
= 80 ppm	SS 316	SS 316	SS 316	Ti / 254 SMO
= 150 ppm	SS 316	SS 316	Ti / 254 SMO	Ti / 254 SMO
= 300 ppm	SS 316	Ti / 254 SMO	Ti / 254 SMO	Ti / 254 SMO
> 300 ppm	Ti / 254 SMO	Ti / 254 SMO	Ti / 254 SMO	Ti / 254 SMO



1800-OILSOL
1800-645765

<https://oilsolutions.com.au/>

sales@oilsolutions.com.au

6 Maintenance

During maintenance, remember:

- The equipment must be maintained by a professional familiar with the safety requirements and risks.
- Only perform maintenance work described in these operating and installation instructions.
- When performing maintenance of any type, observe the respective safety and operation regulations.

CAUTION



Hot surface

Burning hazard
Let the device cool down before maintaining.

CAUTION



High pressure

Hazard of injury due to flung off parts or oil, environmental hazard due to oil.

- Before starting any maintenance or repair to the oil circuit, make sure that the device is depressurized. This applies to the locking screws as well.
- Avoid environmental pollution (oil spills) during cleaning or maintenance of the oil circuit.
- Use drip pans.

If cooling media are used which are possibly contaminated, such as surface water, cooling circuit water (open circuit), heating installation water (specially in the case of old installations) etc., filter having a mesh width of max. 0.6 mm should be provided in the feed line. Furthermore, if such media are used, the unit should be operated with the largest possible mass flow. If the mass flow is too small (partial load) the turbulence in plate heat exchanger may decrease and susceptibility of fouling may increase.

If formation of deposits due to the water quality (e.g. high degrees of hardness or heavy contamination) is expected, the unit should be cleaned at regular intervals. It is possible to clean the unit by rinsing. A weak acid, e.g. 5% phosphoric acid, or the cleaning agents offered by relevant suppliers to clean copper and stainless steel should be used to rinse the unit.

CAUTION



Acid and corrosive substances

Phosphoric acid can harm skin and eyes.
Wear protection gloves and face protection.



If possible, the rinsing process should be carried out in the opposite direction to that of the operating flow and, where necessary, back rinsing connection should be provided in the piping. The unit must then be sufficiently rinsed using clear water to remove all residues of cleaning liquid before the system is put into operating again.

7 Service and repair

This chapter contains information on troubleshooting and correction should an error occur during operation.

Repairs to the unit must be performed by Bühler authorised personnel.

Please contact our Service Department with any questions:

Tel.: +49-(0)2102-498955 or your agent

If the equipment is not functioning properly after correcting any malfunctions and switching on the power, it must be inspected by the manufacturer. Please send the equipment inside suitable packaging to:

Bühler Technologies GmbH

- Reparatur/Service -

Harkortstraße 29

40880 Ratingen

Germany

Please also attach the completed and signed RMA decontamination statement to the packaging. We will otherwise be unable to process your repair order.

You will find the form in the appendix of these instructions, or simply request it by e-mail:

service@buehler-technologies.com.

7.1 Troubleshooting

Problem / Failure	Possible cause	Solution
Cooling capacity not sufficient	– Ambient air temperature is higher than specified	– Select larger model
	– Water flow too low	– Raise water flow
	– Cooling channels clogged	– Cleaning, see chapter Maintenance
	– Oil flow too low	– Increase oil flow
	– Oil channel clogged	– Cleaning, see chapter Maintenance
	– Oil circuit blocked	– Open valves and cocks

Tab. 1: Troubleshooting



1800-OILSOL
1800-645765

<https://oilsolutions.com.au/>

sales@oilsolutions.com.au

8 Disposal

Dispose of the parts in such a way that does not present a danger to other people's health or to the environment. Observe the legal requirements in the country of use for the disposal of electrical components and oils and coolants.



1800-OILSOL
1800-645765

<https://oilsolutions.com.au/>

sales@oilsolutions.com.au

9 Appendices

9.1 Technical data BWT

Technical Data

Material

Stainless steel 1.4401, Cu 99.9% and Cu-free soldering material.
Also Cu-free soldering materials as special versions BWT-N B5-B28, see data sheet 340005.
Flange B60 and up, in Swedish standard SS 2172, DIN 17175.

Operating pressure

static: max. 30 bar
dynamic: 20 bar at 5M load cycle, 3 Hz

Operating oil temperature max. +185 °C

9.1.1 B05 / B08 / B15

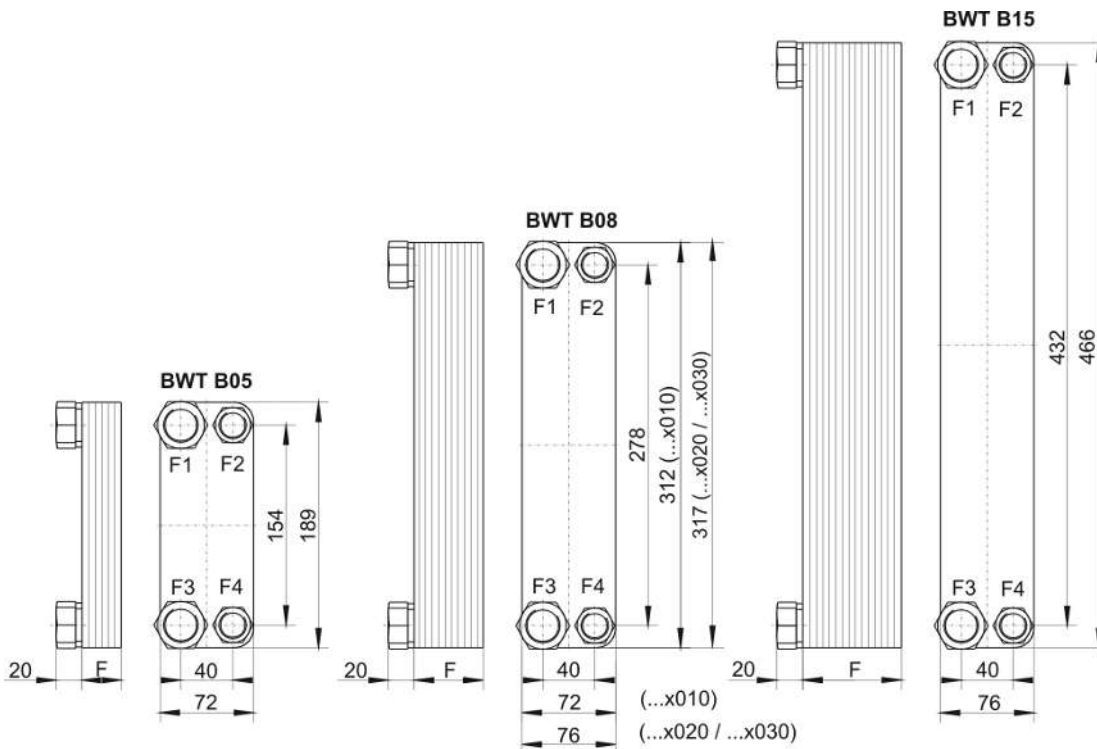

Type	Item no.	F (mm)	Cooling capacity (kW)	Oil connection F3, F1	Water connection F2, F4	Weight (kg – net)	Volume (Litre)
BWT B05x010	3405010	30	1.5 - 5.0	G ¾ 36 mm	G ½ 27 mm	1.0	0.1
BWT B05x020	3405020	53	1.5 - 11	G ¾ 36 mm	G ½ 27 mm	1.5	0.2
BWT B08x010	3408010	30	2.5 - 6.0	G ¾ 36 mm	G ½ 27 mm	1.6	0.5
BWT B08x020	34080200	53	5.0 - 16	G ¾ 36 mm	G ½ 27 mm	2.0	1.0
BWT B08x030	34080300	76	10 - 25	G ¾ 36 mm	G ½ 27 mm	3.0	1.5
BWT B15x030	3415030	76	6.0 - 30	G ¾ 36 mm	G ½ 27 mm	4.0	2.0

9.1.2 B10 / B12 / B25

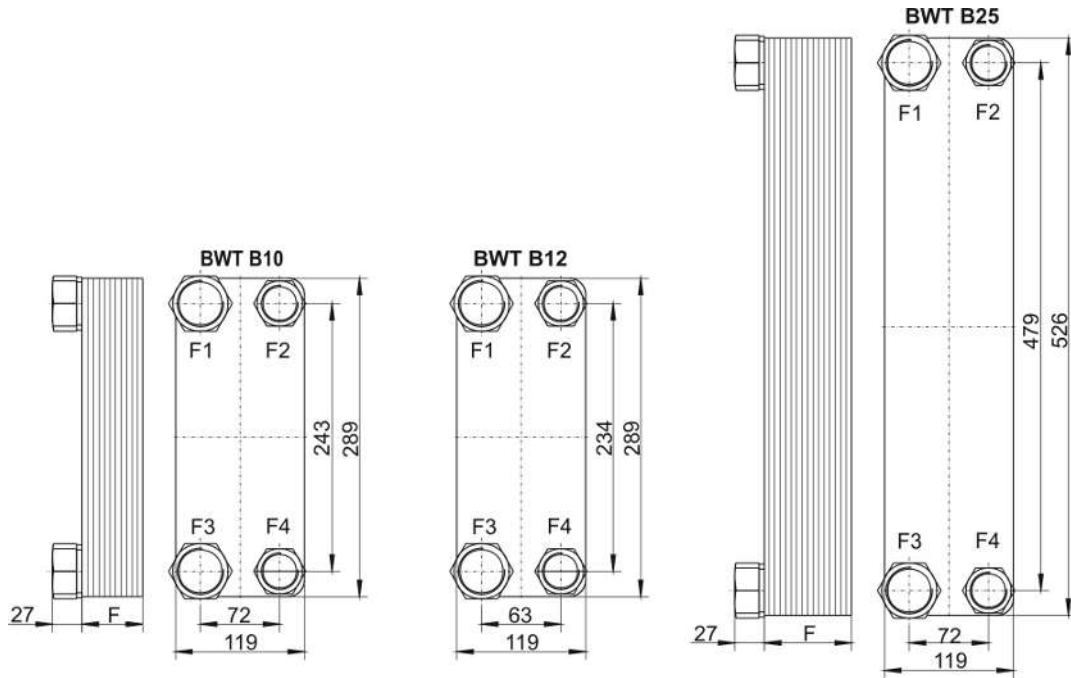

Type	Item no.	F (mm)	Cooling capacity (kW)	Oil connection F3, F1	Water connection F2, F4	Weight (kg – net)	Volume (Litre)
BWT B10x020	3410020	49	5 – 25	G 1/4 11 mm	G 3/4 36 mm	4.0	1.0
BWT B10x030	3410030	72	10 - 40	G 1/4 11 mm	G 3/4 36 mm	5.0	1.5
BWT B10x040	3410040	94	10 - 50	G 1/4 11 mm	G 3/4 36 mm	7.0	2.0
BWT B10x050	3410050	116	15 - 60	G 1/4 50 mm	G 1 1/4 50 mm	8.0	3.0
BWT B10x070	3410070	161	20 - 65	G 1/4 50 mm	G 1 1/4 50 mm	10.0	3.5
BWT B10x090	3410090	206	20 - 80	G 1/4 50 mm	G 1 1/4 50 mm	13.0	4.0
BWT B12Hx060	3412060	145	35 - 85	G 1/4 50 mm	G 1 1/4 50 mm	13.5	4.3
BWT B25x030	3425030	72	13 - 45	G 1/4 50 mm	G 1 1/4 50 mm	10.0	2.0
BWT B25x040	3425040	94	13 - 65	G 1/4 50 mm	G 1 1/4 50 mm	12.0	3.0
BWT B25x060	3425060	139	20 - 90	G 1/4 50 mm	G 1 1/4 50 mm	17.0	5.0
BWT B25x080	3425080	184	25 - 105	G 1/4 50 mm	G 1 1/4 50 mm	21.0	7.0



1800-OILSOL
1800-645765

<https://oilsolutions.com.au/>

sales@oilsolutions.com.au

9.1.3 B35 / B120

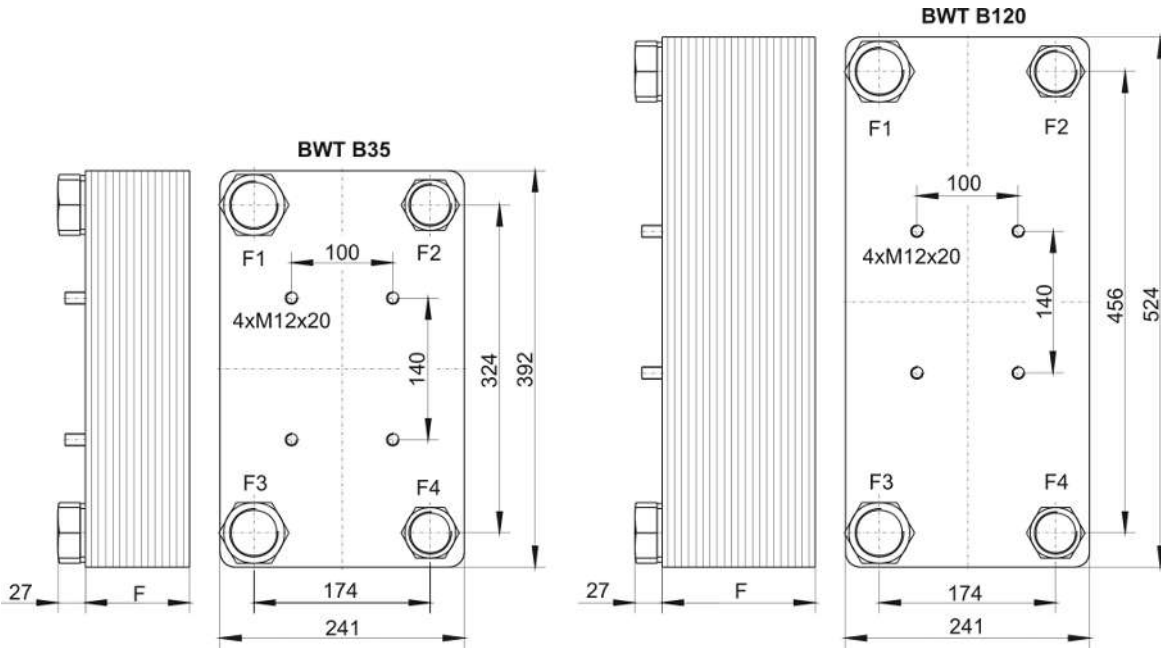

Type	Item no.	F (mm)	Cooling capacity (kW)	Oil connection F3, F1	Water connection F2, F4	Weight (kg – net)	Volume (Litre)
BWT B35x040	3435040	103	30-105	G 1½ 60 mm	G 1¼ 50 mm	18.0	5.0
BWT B35x050	3435050	127	55-145	G 1½ 60 mm	G 1¼ 50 mm	21.0	7.0
BWT B35x060	3435060	151	55-155	G 1½ 60 mm	G 1¼ 50 mm	24.0	8.0
BWT B35x090	3435090	223	55-175	G 1½ 60 mm	G 1¼ 50 mm	34.0	12.0
BWT B120x040	3445040	103	40-125	G 1½ 60 mm	G 1¼ 50 mm	23.0	6.0
BWT B120x060	3445060	151	55-190	G 1½ 60 mm	G 1¼ 50 mm	31.0	10.0
BWT B120x080	3445080	199	65-245	G 1½ 60 mm	G 1¼ 50 mm	40.0	14.0
BWT B120x120	3445120	295	135-280	G 1½ 60 mm	G 1¼ 50 mm	57.0	21.0

9.1.4 B60

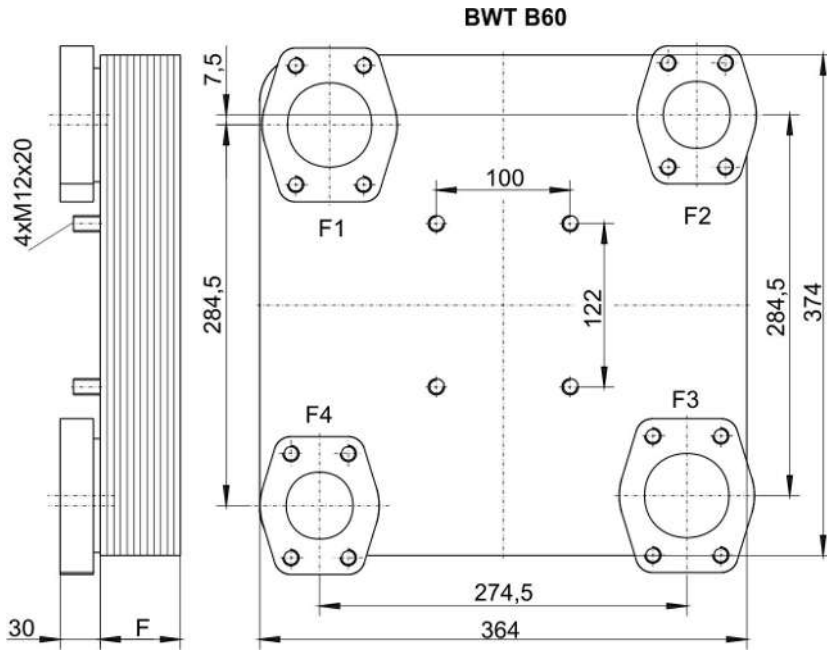

Type	Item no.	F (mm)	Cooling capacity (kW)	Oil connection F3, F1	Water connection F2, F4	Weight (kg – net)	Volume (Litre)
BWT B60x040	3460040	104	30 - 113	SAE 2 ½ *	SAE 2	33	9
BWT B60x060	3460060	147	35 - 165	SAE 2 ½ *	SAE 2	42	13
BWT B60x080	3460080	190	40 - 216	SAE 2 ½ *	SAE 2	52	17
BWT B60x100	3460100	232	43 - 267	SAE 2 ½ *	SAE 2	61	22
BWT B60x120	3460120	275	56 - 301	SAE 2 ½ *	SAE 2	70	26
BWT B60x140	3460140	318	76 - 316	SAE 2 ½ *	SAE 2	80	31

* SAE connections at pressure range 3000 PSI

9.1.5 Mounting brackets

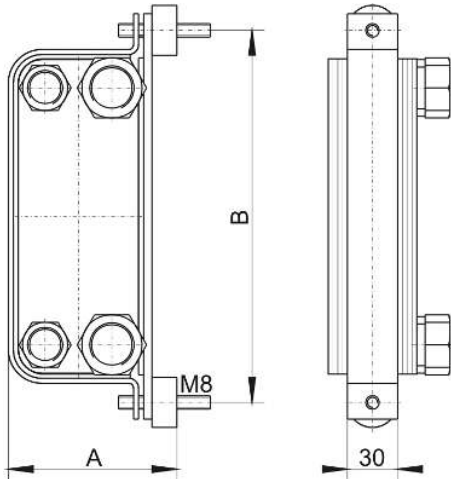

Type	Part no.	A	B	for BWT type
BB05	34BB05	104	223	
BB08	34BB08	104	347	B08 x 010
BB080	34BB080	108	355	B08 x 020 x 030
BB15	34BB15	104	501	
BB10	34BB10	151	323	
BB25	34BB25	151	561	
BB35	34BB35	273	426	
BB 45	34BB45	273	558	

NOTICE! We recommend using two brackets for the types B35-090 and B120-060 up to B120-120.

9.2 Technical data BWT-N

Technical Data

Material Stainless steel 1.4401, Cu-free soldering material (nickel-based solder)

Operating pressure

static: max. 10 bar

Operating oil temperature

+350 °C

9.2.1 B05 / B08 / B15

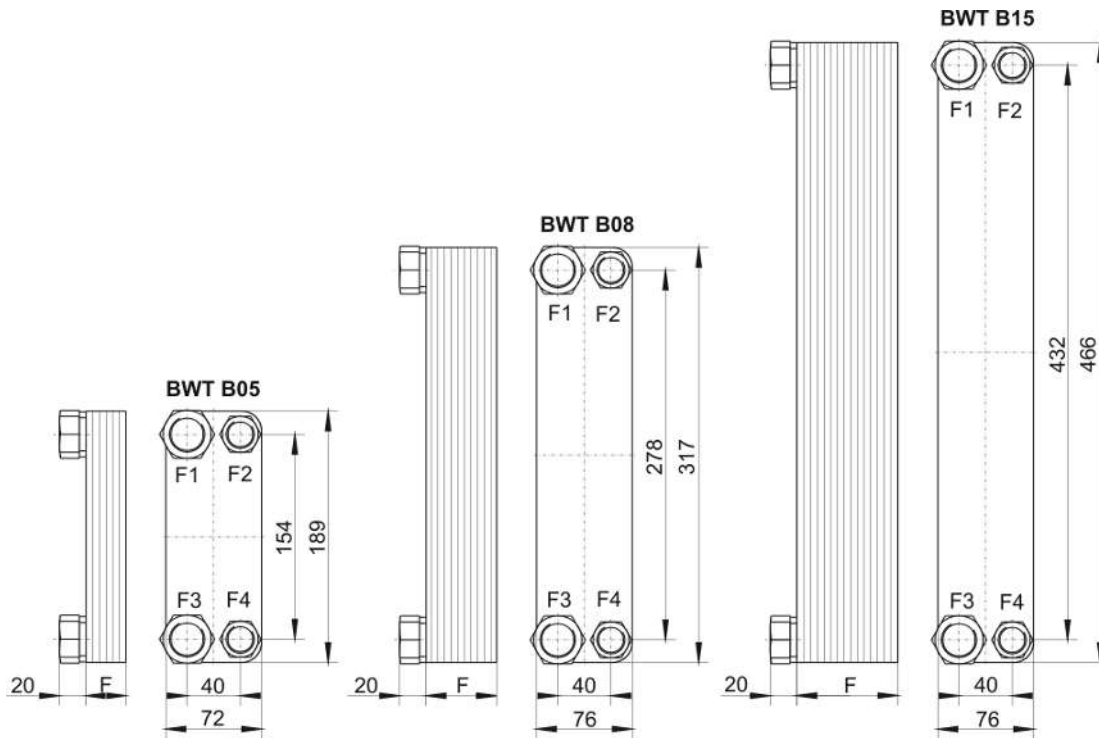

Type	Item no.	F (mm)	Cooling capacity (kW)	Oil connection F3, F1	Water connection F2, F4	Weight (kg – net)	Volume (Litre)
BWT B05x010N	3405010N	30	1.5 - 5.0	G 3/4 36 mm	G 1/2 27 mm	1.0	0.1
BWT B05x020N	3405020N	53	1.5 - 11	G 3/4 36 mm	G 1/2 27 mm	1.5	0.2
BWT B08x010N	34080100N	30	2.5 - 6.0	G 3/4 36 mm	G 1/2 27 mm	1.6	0.5
BWT B08x020N	34080200N	53	5.0 - 16	G 3/4 36 mm	G 1/2 27 mm	2.0	1.0
BWT B08x030N	34080300N	76	10 - 25	G 3/4 36 mm	G 1/2 27 mm	3.0	1.5
BWT B15x030N	3415030N	76	6.0 - 30	G 3/4 36 mm	G 1/2 27 mm	4.0	2.0

9.2.2 B10 / B28

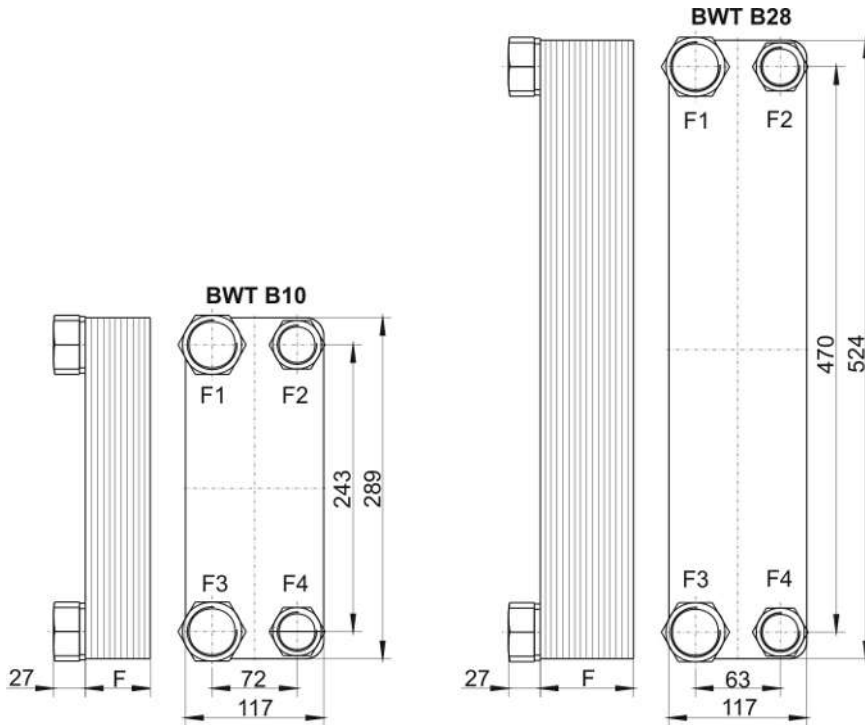

Type	Item no.	F (mm)	Cooling capacity (kW)	Oil connection F3, F1	Water connection F2, F4	Weight (kg – net)	Volume (Litre)
BWT B10x020N	3410020N	55	5 – 25	G 1 41 mm	G ¾ 36 mm	4.0	1.0
BWT B10x030N	3410030N	79	10 - 40	G 1 41 mm	G ¾ 36 mm	5.0	1.5
BWT B10x040N	3410040N	103	10 - 50	G 1 41 mm	G ¾ 36 mm	7.0	2.0
BWT B10x054N	3410054N	137	15 - 60	G 1 50 mm	G ¾ 41 mm	8.0	3.0
BWT B10x070N	3410070N	175	20 - 65	G 1 50 mm	G ¾ 41 mm	10.0	3.5
BWT B10x090N	3410090N	223	20 - 80	G 1 50 mm	G ¾ 41 mm	13.0	4.0
BWT B28x030N	3428030N	79	13 - 45	G 1 ¼ 50 mm	G 1 41 mm	10.0	2.0
BWT B28x040N	3428040N	103	13 - 65	G 1 ¼ 50 mm	G 1 41 mm	12.0	3.0
BWT B28x060N	3428060N	151	20 - 90	G 1 ¼ 50 mm	G 1 ¼ 41 mm	17.0	5.0
BWT B28x080N	3428080N	199	25 - 105	G 1 ¼ 50 mm	G 1 ¼ 41 mm	21.0	7.0

9.2.3 Mounting brackets

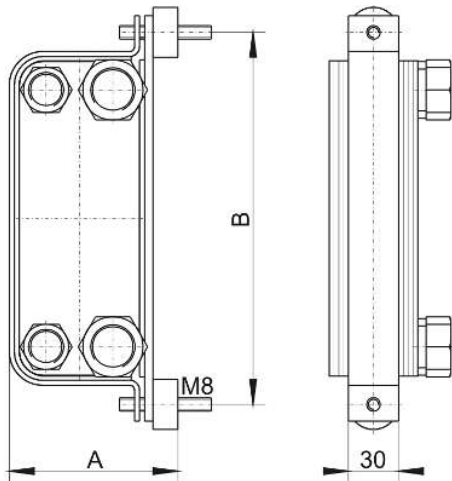

Type	Part no.	A	B
BB05	34BB05	104	223
BB08	34BB080	108	355
BB15	34BB15	104	501
BB10	34BB10	151	323
BB25 / BB28	34BB25	151	561

9.3 Technical Data BWT-DW

Technical Data

Material Stainless steel 1.4401, Cu 99.9 %

Operating pressure

static: max. 16 bar

Operating oil temperature

+155 °C

9.3.1 B16

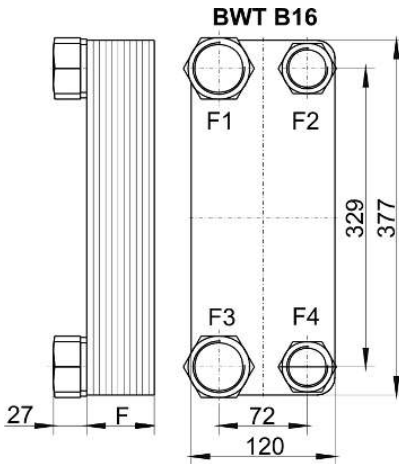

Type	Item no.	F (mm)	Oil connection F3, F1	Water connection F2, F4	Weight (kg – net)	Volume (Litre)
BWT B16x010DW	3416010DW	30	G ¾ 36 mm	G ¾ 36 mm	4.0	0.6
BWT B16x020DW	3416020DW	50	G ¾ 36 mm	G ¾ 36 mm	6.2	1.2
BWT B16x030DW	3416030DW	70	G ¾ 36 mm	G ¾ 36 mm	8.4	1.8
BWT B16x040DW	3416040DW	90	G ¾ 36 mm	G ¾ 36 mm	10.6	2.4
BWT B16x050DW	3416050DW	110	G ¾ 36 mm	G ¾ 36 mm	12.8	3.0
BWT B16x060DW	3416060DW	130	G ¾ 36 mm	G ¾ 36 mm	15.0	3.6
BWT B16x070DW	3416070DW	150	G ¾ 36 mm	G ¾ 36 mm	17.2	4.2

9.3.2 Mounting bracket

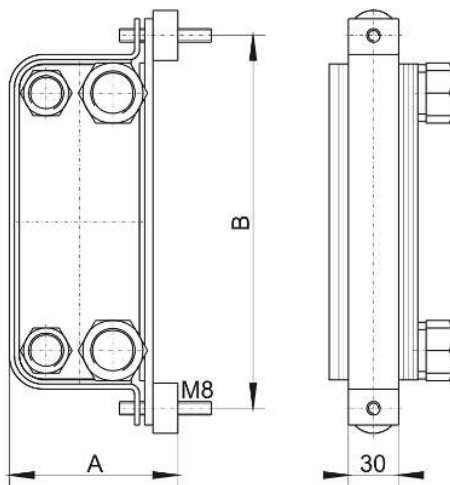

Type	Item no.	A	B
BB16	34BB16	148	411

9.4 Approvals

BWT plate coolers are approved by the following authorities:

Sweden	Statens Anläggningsprovning (SA)
Norway	Kjelkontrollen
Canada	Canadian Standard Association (CSA)
Germany	Technischer Überwachungsverein (TÜV)
USA	Underwriters Laboratories (UL)
Finland	Teknillinen Tarkastuskeskus (TK)
Switzerland	Schweizerischer Verein des Gas- und Wasserfaches (SVGW)
EU	TRB801 No. 25

Bühler is ISO 9001 certified

9.5 Calculations

9.5.1 Calculating viscosity

Valid for VG-oil between 10 - 100 °C at an exactness from ± 5 %.

	Definitions		Example: oil VG 46
V_{40}	oil viscosity at 40 °C in cst	V_{40}	46 cst
T	temperature in °C	T	25 °C
ν	viscosity in cst		
	$b = 159 \cdot \ln \frac{V_{40}}{0,23}$		$b = 159 \cdot \ln \frac{46}{0,23} = 842,4325$
	$a = 0,23 \cdot e^{\frac{-b}{877}}$		$a = 0,23 \cdot e^{\frac{-842,4325}{877}} = 0,08801$
	$\nu = a \cdot e^{\frac{b}{T+95,2}}$		$\nu = 0,08801 \cdot e^{\frac{842,4325}{25+95,2}} = 97,35 \text{ cst}$

9.5.2 Table of operational viscosity for VG oil

	10 °C	20 °C	30 °C	40 °C	50 °C	60 °C	70 °C	80 °C	90 °C
VG 46	264,45	131,96	73,58	46,00	29,13	20,04	14,43	10,78	8,32
VG 68	444,77	210,85	112,61	68,00	41,63	27,86	19,58	14,32	10,84
VG 220	2.120,17	861,60	404,31	220,00	121,71	74,99	49,00	33,61	24,01
VG 320	3.489,92	1.350,22	607,96	320,00	171,40	102,85	65,66	44,12	30,94

Viscosity given in cst (mm²/s)



9.5.3 Calculating the pressure loss

Valid for smooth straight piping per meter at laminar current.

	Definitions
ν	Viscosity in cst
ρ	spec. gravity in kg/dm ³
DN	tube diameter in mm
V	flow in m/s
PV	pressure loss in bar

$$PV = \frac{0,32 \cdot \nu \cdot \rho \cdot V}{DN^2}$$

Example: oil VG 46

ν	97,35 cst
ρ	0,8817 kg/dm ³
DN	20 mm
V	3,18 m/s (60 l/min for tube DN 20)

$$PV = \frac{0,32 \cdot 97,35 \cdot 0,8817 \cdot 3,18}{20^2} = 0,22 \text{ bar}$$

NOTICE



Pressure loss increases significantly for bends and fittings. It might be necessary in some cases to determine the final shape of the suction line on site under specific conditions.

Please do not hesitate to contact us for help to calculate the pressure loss of the suction line for you specific application.

NOTICE



To avoid damage of the cooling system, make sure that the maximum pump pressure is not exceeded. High pressure may occur if the system is shut off or throttled at the pressure side.

9.6 Pressure loss in straight pipes

Pressure loss (bar) per metre in straight tubing with laminar flow of mineral oil:

BFP 8 8 l/min – DN 25

	VG 46	VG 68	VG 120	VG 160	VG 220	VG 320	VG 460	VG 680
10 °C	0.03	0.05	0.11	0.17	0.25	0.42	0.68	1.14
20 °C	0.02	0.03	0.05	0.07	0.10	0.16	0.25	0.40
30 °C	0.01	0.01	0.02	0.03	0.05	0.07	0.11	0.17
40 °C	0.01	0.01	0.01	0.03	0.03	0.04	0.05	0.08
50 °C	0.01	0.01	0.01	0.02	0.01	0.02	0.03	0.04
60 °C – 100 °C	< 0.03 bar							

BFP 15 16 l/min – DN 32

	VG 46	VG 68	VG 120	VG 160	VG 220	VG 320	VG 460	VG 680
10 °C	0.02	0.04	0.08	0.12	0.19	0.31	0.50	0.85
20 °C	0.01	0.02	0.04	0.10	0.08	0.12	0.19	0.30
30 °C	0.01	0.01	0.02	0.05	0.04	0.05	0.08	0.12
40 °C	0.01	0.01	0.01	0.01	0.02	0.03	0.04	0.06
50 °C	0.01	0.01	0.01	0.01	0.01	0.02	0.01	0.03
60 °C – 100 °C	< 0.02 bar							

BFP 30 28 l/min – DN 32

	VG 46	VG 68	VG 120	VG 160	VG 220	VG 320	VG 460	VG 680
10 °C	0.04	0.07	0.15	0.22	0.33	0.54	0.88	1.48
20 °C	0.02	0.03	0.06	0.09	0.13	0.21	0.33	0.52
30 °C	0.01	0.02	0.03	0.04	0.07	0.09	0.14	0.22
40 °C	0.01	0.01	0.02	0.02	0.03	0.05	0.07	0.10
50 °C	0.01	0.01	0.01	0.01	0.02	0.03	0.04	0.06
60 °C – 100 °C	< 0.03 bar							

BFP 60 57 l/min – DN 40

	VG 46	VG 68	VG 120	VG 160	VG 220	VG 320	VG 460	VG 680
10 °C	0.03	0.06	0.12	0.18	0.28	0.45	0.74	1.24
20 °C	0.02	0.03	0.05	0.08	0.11	0.18	0.27	0.43
30 °C	0.01	0.01	0.03	0.04	0.05	0.08	0.12	0.18
40 °C	0.01	0.01	0.02	0.02	0.02	0.04	0.06	0.08
50 °C	0.01	0.01	0.01	0.01	0.02	0.02	0.03	0.05

60 °C – 100 °C < 0.03 bar

BFP 90 86 l/min – DN 40

	LVG 46	VG 68	VG 120	VG 160	VG 220	VG 320	VG 460	VG 680
10 °C	0.05	0.09	0.19	0.27	0.42	0.68	1.11	1.87
20 °C	0.03	0.04	0.08	0.12	0.17	0.26	0.41	0.65
30 °C	0.02	0.02	0.04	0.06	0.08	0.12	0.18	0.27
40 °C	0.01	0.01	0.02	0.03	0.04	0.06	0.09	0.13
50 °C	0.01	0.01	0.01	0.02	0.02	0.03	0.05	0.07

60 °C – 100 °C < 0.04 bar

Note: Values in blue exceed the suction operation limit of -0.4 bar.

10 Attached documents

- Decontamination statement



1800-OILSOL
1800-645765

<https://oilsolutions.com.au/>

sales@oilsolutions.com.au

RMA-Formular und Erklärung über Dekontaminierung

RMA-Form and explanation for decontamination



RMA-Nr./ RMA-No.

Die RMA-Nummer bekommen Sie von Ihrem Ansprechpartner im Vertrieb oder Service./ You may obtain the RMA number from your sales or service representative.

Zu diesem Rücksendeschein gehört eine Dekontaminierungserklärung. Die gesetzlichen Vorschriften schreiben vor, dass Sie uns diese Dekontaminierungserklärung ausgefüllt und unterschrieben zurücksenden müssen. Bitte füllen Sie auch diese im Sinne der Gesundheit unserer Mitarbeiter vollständig aus./ This return form includes a decontamination statement. The law requires you to submit this completed and signed decontamination statement to us. Please complete the entire form, also in the interest of our employee health.

Firma/ Company

Firma/ Company

Straße/ Street

PLZ, Ort/ Zip, City

Land/ Country

Gerät/ Device

Anzahl/ Quantity

Auftragsnr./ Order No.

Ansprechpartner/ Person in charge

Name/ Name

Abt./ Dept.

Tel./ Phone

E-Mail

Serien-Nr./ Serial No.

Artikel-Nr./ Item No.

Grund der Rücksendung/ Reason for return

- Kalibrierung/ Calibration Modifikation/ Modification
 Reklamation/ Claim Reparatur/ Repair
 andere/ other

bitte spezifizieren/ please specify

Ist das Gerät möglicherweise kontaminiert?/ Could the equipment be contaminated?

- Nein, da das Gerät nicht mit gesundheitsgefährdenden Stoffen betrieben wurde./ No, because the device was not operated with hazardous substances.
 Nein, da das Gerät ordnungsgemäß gereinigt und dekontaminiert wurde./ No, because the device has been properly cleaned and decontaminated.
 Ja, kontaminiert mit:/ Yes, contaminated with:



explosiv/
explosive



entzündlich/
flammable



brandfördernd/
oxidizing



komprimierte
Gase/
compressed
gases



ätzend/
caustic



giftig,
Lebensgefahr/
poisonous, risk
of death



gesundheitsge-
fährdend/
harmful to
health



gesund-
heitsschädlich/
health hazard



umweltge-
fährdend/
environmental
hazard

Bitte Sicherheitsdatenblatt beilegen!/ Please enclose safety data sheet!

Das Gerät wurde gespült mit:/ The equipment was purged with:

Diese Erklärung wurde korrekt und vollständig ausgefüllt und von einer dazu befugten Person unterschrieben. Der Versand der (dekontaminierten) Geräte und Komponenten erfolgt gemäß den gesetzlichen Bestimmungen.

This declaration has been filled out correctly and completely, and signed by an authorized person. The dispatch of the (decontaminated) devices and components takes place according to the legal regulations.

Falls die Ware nicht gereinigt, also kontaminiert bei uns eintrifft, muss die Firma Bühler sich vorbehalten, diese durch einen externen Dienstleister reinigen zu lassen und Ihnen dies in Rechnung zu stellen.

Should the goods not arrive clean, but contaminated, Bühler reserves the right, to commission an external service provider to clean the goods and invoice it to your account.

Firmenstempel/ Company Sign

Datum/ Date

Bühler Technologies GmbH, Harkortstr. 29, D-40880 Ratingen
Tel. +49 (0) 21 02 / 49 89-0, Fax: +49 (0) 21 02 / 49 89-20
E-Mail: service@buehler-technologies.com
Internet: www.buehler-technologies.com

rechtsverbindliche Unterschrift/ Legally binding signature

DE000011
01/2019



1800-OILSOL
1800-645765

<https://oilsolutions.com.au/>

sales@oilsolutions.com.au



Die Analyse defekter Baugruppen ist ein wesentlicher Bestandteil der Qualitätssicherung der Firma Bühler Technologies.

Um eine aussagekräftige Analyse zu gewährleisten muss die Ware möglichst unverändert untersucht werden. Es dürfen keine Veränderungen oder weitere Beschädigungen auftreten, die Ursachen verdecken oder eine Analyse unmöglich machen.

Bei elektronischen Baugruppen kann es sich um elektrostatisch sensible Baugruppen handeln. Es ist darauf zu achten, diese Baugruppen ESD-gerecht zu behandeln. Nach Möglichkeit sollten die Baugruppen an einem ESD-gerechten Arbeitsplatz getauscht werden. Ist dies nicht möglich sollten ESD-gerechte Maßnahmen beim Austausch getroffen werden. Der Transport darf nur in ESD-gerechten Behältnissen durchgeführt werden. Die Verpackung der Baugruppen muss ESD-konform sein. Verwenden Sie nach Möglichkeit die Verpackung des Ersatzteils oder wählen Sie selber eine ESD-gerechte Verpackung.

Beachten Sie beim Einbau des Ersatzteils die gleichen Vorgaben wie oben beschrieben. Achten Sie auf die ordnungsgemäße Montage des Bauteils und aller Komponenten. Versetzen Sie vor der Inbetriebnahme die Verkabelung wieder in den ursprünglichen Zustand. Fragen Sie im Zweifel beim Hersteller nach weiteren Informationen.

Analysing defective assemblies is an essential part of quality assurance at Bühler Technologies.

To ensure conclusive analysis the goods must be inspected unaltered, if possible. Modifications or other damages which may hide the cause or render it impossible to analyse are prohibited.

Electronic assemblies may be sensitive to static electricity. Be sure to handle these assemblies in an ESD-safe manner. Where possible, the assemblies should be replaced in an ESD-safe location. If unable to do so, take ESD-safe precautions when replacing these. Must be transported in ESD-safe containers. The packaging of the assemblies must be ESD-safe. If possible, use the packaging of the spare part or use ESD-safe packaging.

Observe the above specifications when installing the spare part. Ensure the part and all components are properly installed. Return the cables to the original state before putting into service. When in doubt, contact the manufacturer for additional information.



1800-OILSOL
1800-645765

<https://oilsolutions.com.au/>

sales@oilsolutions.com.au

