



Pressure sensors/pressure switches

Pressotronik PT77

Installation and Operation Instructions

Original instructions



1800-OILSOL
1800-645765

<https://oilsolutions.com.au/>

sales@oilsolutions.com.au





Bühler Technologies GmbH, Harkortstr. 29, D-40880 Ratingen
Tel. +49 (0) 21 02 / 49 89-0, Fax: +49 (0) 21 02 / 49 89-20
Internet: www.buehler-technologies.com
E-Mail: fluidcontrol@buehler-technologies.com

Read this instruction carefully prior to installation and/or use. Pay attention particularly to all advises and safety instructions to prevent injuries. Bühler Technologies can not be held responsible for misusing the product or unreliable function due to unauthorised modifications.

All rights reserved. Bühler Technologies GmbH 2022

Document information

Document No..... BE130003
Version..... 06/2022



1800-OILSOL
1800-645765

<https://oilsolutions.com.au/>

sales@oilsolutions.com.au

Contents

1	Introduction.....	3
1.1	Intended Use.....	3
1.2	Functionality.....	3
1.2.1	Pressure monitoring.....	3
1.3	Design types.....	3
1.4	Model key.....	3
1.5	Contents.....	4
2	Safety instructions.....	5
2.1	Important advice.....	5
2.2	General hazard warnings.....	5
3	Transport and storage.....	7
4	Setup and connection.....	8
4.1	Installation.....	8
4.1.1	Upside down pressure sensor installation.....	9
4.2	Electrical connections.....	10
5	Operation and control.....	11
5.1	Start-up procedure.....	11
5.2	LED statuses.....	11
5.3	General key functions.....	12
5.4	Keylock enabled.....	12
5.5	Menu overview.....	13
5.6	Changing basic settings.....	14
5.6.1	Disabling normal error handling.....	14
5.6.2	Define switching outputs.....	14
5.6.3	Changing the display direction.....	15
5.6.4	Setting the pressure unit.....	15
5.6.5	Setting the maximum pressure.....	15
5.6.6	Set display refresh rate.....	16
5.6.7	Enable/disable keylock.....	16
5.6.8	Restore factory settings (Reset).....	16
5.7	Switching outputs.....	18
5.7.1	Switching output x: Definition of the switching characteristic.....	19
5.7.2	Switching output x: Upper switching limit (switching point).....	20
5.7.3	Switching output x: Lower switching limit (switch-back point).....	20
5.7.4	Switching output x: Switch-on delay.....	21
5.7.5	Switching output x: Switch-back delay.....	21
5.7.6	Switching output x: Testing the switching output.....	21
5.7.7	Change status LED display function.....	22
5.8	Analogue outputs.....	23
5.8.1	Analogue output x: Assigning the upper limit.....	23
5.8.2	Analogue output x: Lower limit assignment.....	23
5.8.3	Analogue output x: Signal type assignment.....	23
5.8.4	Analogue output x: Testing the analogue output.....	24
5.9	Diagnostic options.....	24
5.9.1	View logbook.....	24
5.9.2	Maximum and minimum pressure.....	25
5.9.3	Define switching output to log.....	25
5.9.4	Delay for storing the Min/Max pressure.....	26
6	Cleaning and Maintenance.....	27
7	Service and repair.....	28
7.1	Troubleshooting.....	28
7.2	Spare parts and accessories.....	29
8	Disposal.....	30
9	Appendices.....	31

9.1	Technical Data Pressotronik 700	31
9.2	Technical Data Pressotronik 770	33
9.3	Technical Data Pressotronik 771	34
9.4	Standard pin assignment Pressotronik 770	35
9.5	Standard pin assignment Pressotronik 770 and 771	35
9.6	Current settings	36
9.7	Display ranges	36
9.8	Display resolution	36
9.9	Menu Sequence Overview	38
10	Attached documents	39



1800-OILSOL
1800-645765

<https://oilsolutions.com.au/>

sales@oilsolutions.com.au

1 Introduction

1.1 Intended Use

These devices are pressure sensors or pressure switches for indicating and controlling the pressure in fluid systems.

Please note the technical data in the appendix for the specific intended use, existing material combinations, as well as pressure and temperature limits.

WARNING



All device models are solely intended for industrial applications. They are **not safety components**. The devices must not be used if failure or malfunction thereof jeopardises the safety and health of persons. Use in explosive areas is **prohibited**.

1.2 Functionality

1.2.1 Pressure monitoring

In pressure monitoring a pressure sensor is located directly on the tank or on the piping and has a line connecting it to the display unit or the control room. Alternatively, a pressure sensor with attached display electronics is used. A ceramic or stainless steel measuring cell serves as the sensor element. These can have an application range of a few millibar to several hundred bar. The hydraulic pressure applied to the measuring cell is recorded by a sensor element attached to the measuring cell and processed or displayed by downstream electronics. Regular switching signals as well as continuous voltage or current signals can be used as the output signals.

Clocked signals with variable output frequency can also be used, for example to record a quasi-continuous pressure signal via the frequency input on an SPS (eliminating the use of an expensive analogue input card for the SPS).

1.3 Design types

The Pressotronik is equipped with different switching and analogue outputs based on the configuration.

Choose from the following pressure sensors or pressure switches:

- PT 770-x** This version allows the display and control unit to be positioned anywhere. The pressure sensor may be installed directly at the measuring point. The sensor and display connect via cable with M12 plugs.
- PT 771-x** With this version the pressure transmitter is built into the display and control unit. The unit is installed directly at the measuring point.

Please refer to the type plate for your equipment configuration. In addition to the job number, this also contains the item number and type designation

1.4 Model key

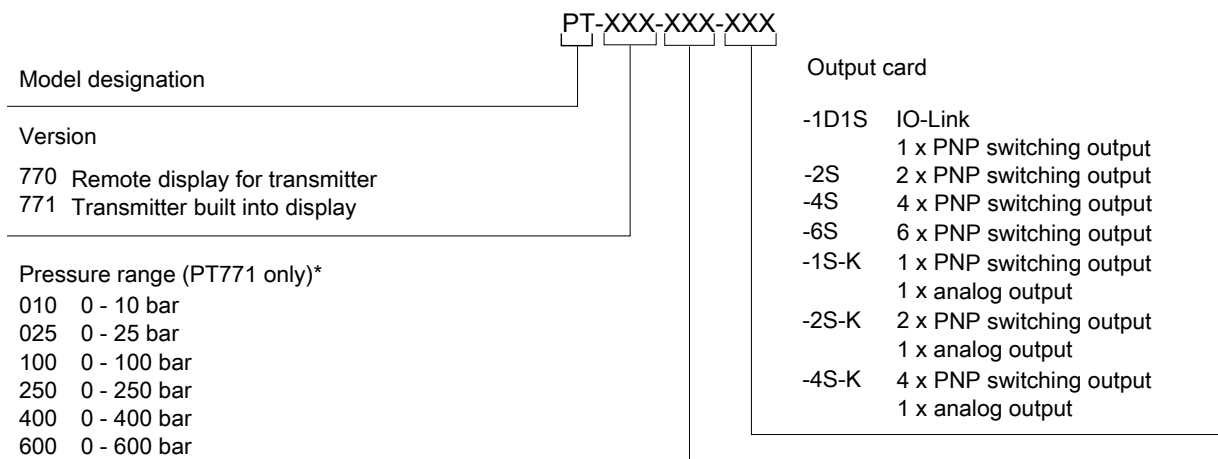

*on PT770 the pressure range can be preset at the factory.

1.5 Contents

- Pressotronik
- Product documentation
- Connection/mounting accessories (optional)



1800-OILSOL
1800-645765

<https://oilsolutions.com.au/>

sales@oilsolutions.com.au

2 Safety instructions

2.1 Important advice

Operation of the device is only permitted if:

- the product is used under the conditions described in the installation- and operation instruction, the intended application according to the type plate and the intended use. In case of unauthorized modifications done by the user Bühler Technologies GmbH can not be held responsible for any damage,
- when complying with the specifications and markings on the nameplates.
- the performance limits given in the datasheets and in the installation- and operation instruction are obeyed,
- monitoring devices and safety devices are installed properly,
- service and repair is carried out by Bühler Technologies GmbH,
- only original spare parts are used.





This manual is part of the equipment. The manufacturer keeps the right to modify specifications without advanced notice. Keep this manual for later use.

Signal words for warnings

DANGER	Signal word for an imminent danger with high risk, resulting in severe injuries or death if not avoided.
WARNING	Signal word for a hazardous situation with medium risk, possibly resulting in severe injuries or death if not avoided.
CAUTION	Signal word for a hazardous situation with low risk, resulting in damaged to the device or the property or minor or medium injuries if not avoided.
NOTICE	Signal word for important information to the product.

Warning signs

These instructions use the following warning signs:

	Warns of a general hazard		General information
	Voltage warning		Unplug from mains
	High pressure warning		

2.2 General hazard warnings

The equipment must be installed by a professional familiar with the safety requirements and risks.

Be sure to observe the safety regulations and generally applicable rules of technology relevant for the installation site. Prevent malfunctions and avoid personal injuries and property damage.

The operator of the system must ensure:

- Safety notices and operating instructions are available and observed,
- The respective national accident prevention regulations are observed,
- The permissible data and operational conditions are maintained,
- Safety guards are used and mandatory maintenance is performed,
- Legal regulations are observed during disposal,
- compliance with national installation regulations.

Maintenance, Repair

Please note during maintenance and repairs:

- Repairs to the unit must be performed by Bühler authorised personnel.
- Only perform conversion-, maintenance or installation work described in these operating and installation instructions.
- Always use genuine spare parts.
- Do not install damaged or defective spare part. If necessary, visually inspect prior to installation to determine any obvious damage to the spare parts.

Always observe the applicable safety and operating regulations in the respective country of use when performing any type of maintenance.

The method for cleaning the devices must be adapted to the IP protection class of the devices. Do not use cleaners which could damage the device materials.



1800-OILSOL
1800-645765

<https://oilsolutions.com.au/>

sales@oilsolutions.com.au

3 Transport and storage

Only transport the product inside the original packaging or a suitable alternative.

The equipment must be protected from moisture and heat when not in use. It must be stored in a covered, dry, dust-free room at room temperature.



1800-OILSOL
1800-645765

<https://oilsolutions.com.au/>

sales@oilsolutions.com.au

4 Setup and connection

DANGER

Electric voltage

Risk of electric shock

- a) Always disconnect the unit from the mains before performing work.
- b) Secure the equipment from accidental restarting.
- c) The equipment may only be installed, maintained and put into operation by instructed, competent personnel.
- d) Always observe the applicable safety regulations for the operating site.



DANGER

Toxic, acidic gases/liquids

Protect yourself from toxic, corrosive gasses/liquids when performing any type of work. Wear appropriate protective equipment.



4.1 Installation

WARNING

Gases or liquids discharged under pressure

Depressurise the system before installing or removing the transmitter.



The Pressotronik housing mounts to a 35 mm (1.4") top-hat rail. This allows it to easily be mounted in a central location without additional mounting aids or installed in control cabinets. The hydraulic connection for the transmitter is carried out via G $\frac{1}{4}$ external thread, DIN 3852 shape E. The transmitter connects to the display and control unit via cable with M12 plug-in connector.

When direct mounting the (display and control unit with transmitter), the unit screws into the transmitter. Only use the spanner (SW 21) on the hexagon flat. Avoid force being transmitted via the housing.

Pressotronik

Display and control unit with offset transmitter, for top-hat rail mounting 35 mm (1.4").

Display and control unit with built-in transmitter, for direct mounting.

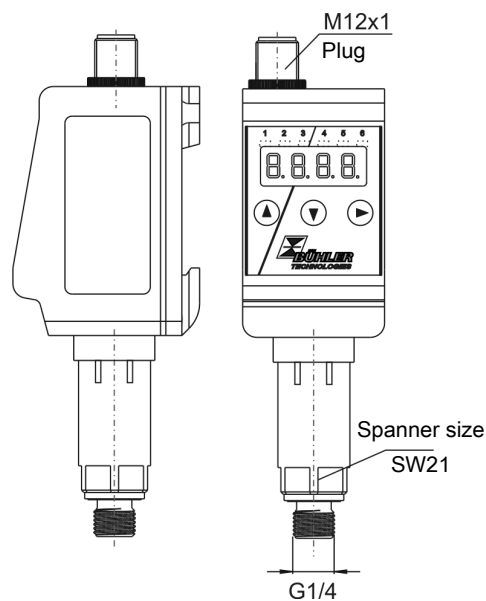
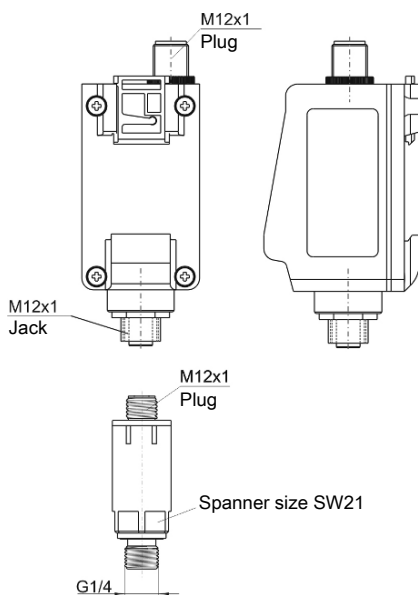

DANGER

Electric voltage



Risk of electric shock

When connecting devices, please note the maximum voltages and currents (see technical data) and use the correct wire cross-sections and circuit breakers. When selecting the connection lines, also note the maximum operating temperatures of the devices.

Installation in special areas of application:

If the device will be installed outdoors or in wet areas, the maximum operating voltage is max. 16 V DC effective or 35 V DC.



4.1.1 Upside down pressure sensor installation

The **Pressotronik 771** can also be installed rotated by 180°.

The hydraulic connection for the transmitter is carried out via G $\frac{1}{4}$ external thread, DIN 3852 shape E. Depending on the desired position, the sensor can be mounted facing up or down.

Only use the spanner (SW 21) on the hexagon flat when mounting. Avoid force being transmitted via the housing.

Pressotronik 771

Display and control unit with built-in transmitter (upright)

Pressotronik 771

Display and control unit with built-in transmitter (upside down)

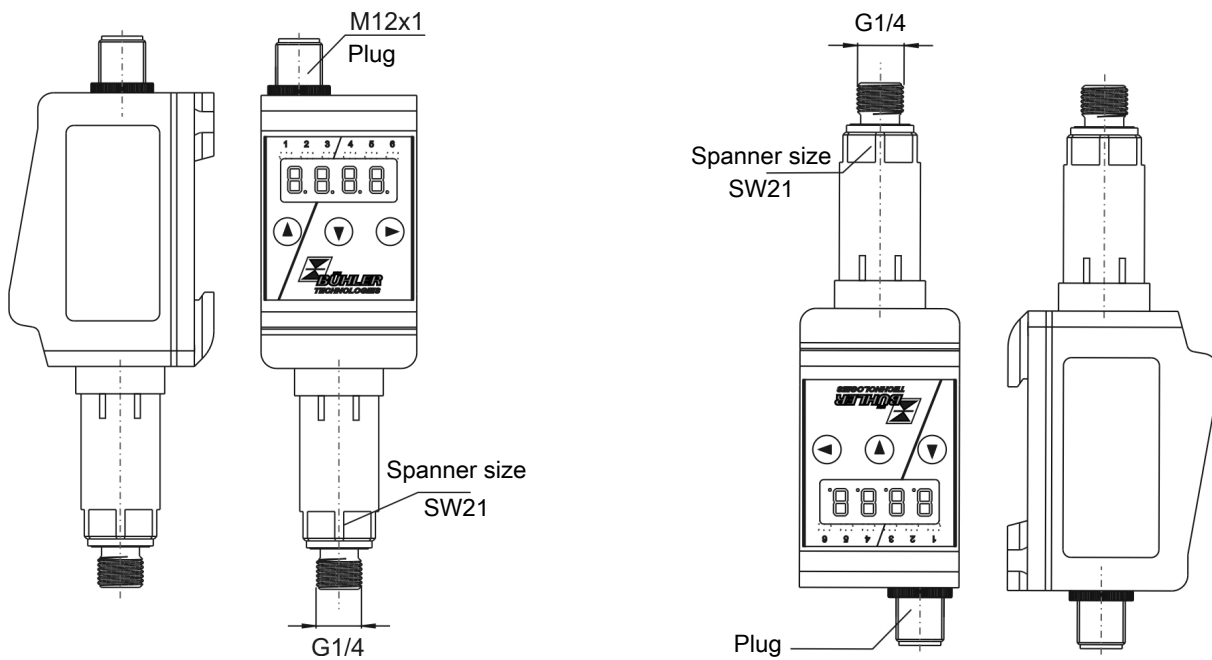

Please note the following particularities when turning the Pressotronik:

- The key order changes, the ► key now points to the left (◄) and is located on the left.
- The ▲ and ▼ keys remain the same.
- Even with it being at the top end of the numbers when turning the display, the decimal point is a decimal place.

4.2 Electrical connections

A cable connects the sensor to a jack at the bottom of the device. This cable also supplies the input signal for the sensor.

Electricity is supplied via plug connectors. Please refer to the appendix for installation dimensions, nominal voltage and plug configuration.

The temperature switching outputs are PNP transistors (see illustration):

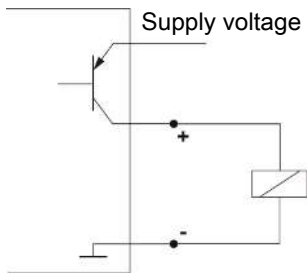

Note: When measuring the switching output with high-load measuring device inputs or when used as a frequency output, the load must be set to 10 k Ω between the output and earth (GND) to avoid faulty measurements.

5 Operation and control

NOTICE



The device must not be operated beyond its specifications.

5.1 Start-up procedure

The device will automatically switch on when connected to power. It will first briefly display the software version, at which time the device will also check the built-in components. The display will then switch to displaying measurements.

The following describes the function of the display and control unit:

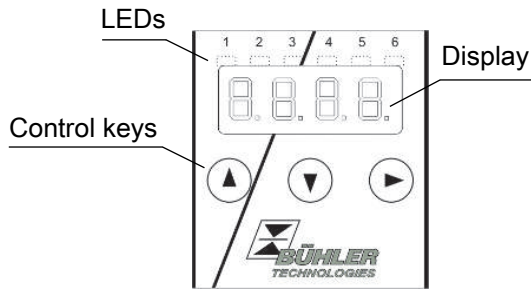

If an error message appears in the display during operation, please refer to the **Troubleshooting** table under chapter “Service and Repair”.

5.2 LED statuses

LEDs above the measurement display indicate the status of the switching outputs. The LEDs are permanently assigned to the switching outputs.

The following table shows the factory settings:

	LED 1 – yellow Status switching output 1
	LED 2 - red Status switching output 2 (if applicable)
	LED 3 – yellow Status switching output 3 (if applicable)
	LED 4 – red Status switching output 4 (if applicable)
	LED 5 – yellow Status switching output 5 (if applicable)
	LED 6 – red Status switching output 6 (if applicable)

The switching characteristics of the LED (on if switching contact closed or open) can be changed.

5.3 General key functions

The keys below the display are used for operation.

The menu controls are detailed in the following chapters.

Key	Mode	Function
▶	– Measurement display:	Toggles the display unit.
	– In the menu:	Move down one menu level. Move up one menu level.
	– At the end of the menu:	 The display indicates the end of the menu.
	– Following input/selection:	Confirm and save a numerical value entered or a function selection. The display will flash if a parameter has been changed.
▲	– Measurement display:	Displays the configuration.
	– In the menu:	Scroll up menu item, numerical value or function selection. Holding the key will continuously scroll.
▼	– Measurement display:	Go to main menu.
	– In the menu:	Scroll down menu item, numerical value or function selection. Holding the key will continuously scroll.
▼ + ▶	– In the menu:	Exit the main / sub / drop-down menu and return to displaying the measurement without saving changes to the parameters.
▲ + ▶	– In the menu:	Move to the next higher menu level.
60 s no action	– In the menu:	Exit the main / sub/ drop-down menu.

To select a menu item and to enter values:

- Open the main menu with the ▼ key.
- Select the submenu with the ▼ and ▲ keys and open the submenu with the ▶ key.
- If necessary, select the next submenu with the ▼ and ▲ keys and open with the ▶ key.
- Select the desired menu item with the ▼ and ▲ keys and open the list of values with the ▶ key.
- Set the value with the ▼ and ▲ keys and confirm with the ▶ key. The new settings will be saved and the device will return to the submenu.
- Select the menu item EXIT to exit the submenu and confirm with the ▶ key. The device will return to the next menu level up or to the measurement display.

5.4 Keylock enabled

With the keylock enabled, selecting the menu with the ▼ key will display  in place of the main menu. The active digit will be indicated by a dot.

- Use the ▲ and ▼ keys to enter the code and confirm with the ▶ key. The active digit will move one place to the right. After entering the 3rd digit the main menu will open.

If the wrong code is entered, the device will return to the measurement display. If you forgot the password you can always enter master code 287 to access the menu.

You can cancel the keylock under *Loc* in submenu **Basic Settings Advanced Options** *bEF* and enter 000 to reset the code.

5.5 Menu overview

The menu structure is based on the VDMA standard sheet 24574-1. The menu structure is hierarchic. The top menu level contains the main menu items, e.g. *PrES*, *bEF*, *d, R*, *E*. Each main menu has additional submenu items.

The menu items may vary depending on the device configuration. Not all menu items described below will necessarily apply to your device. Press the ▲ key in display mode to open the configuration. A 4-digit code will appear, e.g.



With the 4 digits tsav meaning:

t: Model

s: Number of switching outputs

a: Number of analogue outputs

v: Device installation type

P = pressure measurement

2, 4 or 6

0 for 1

i = no differentiation

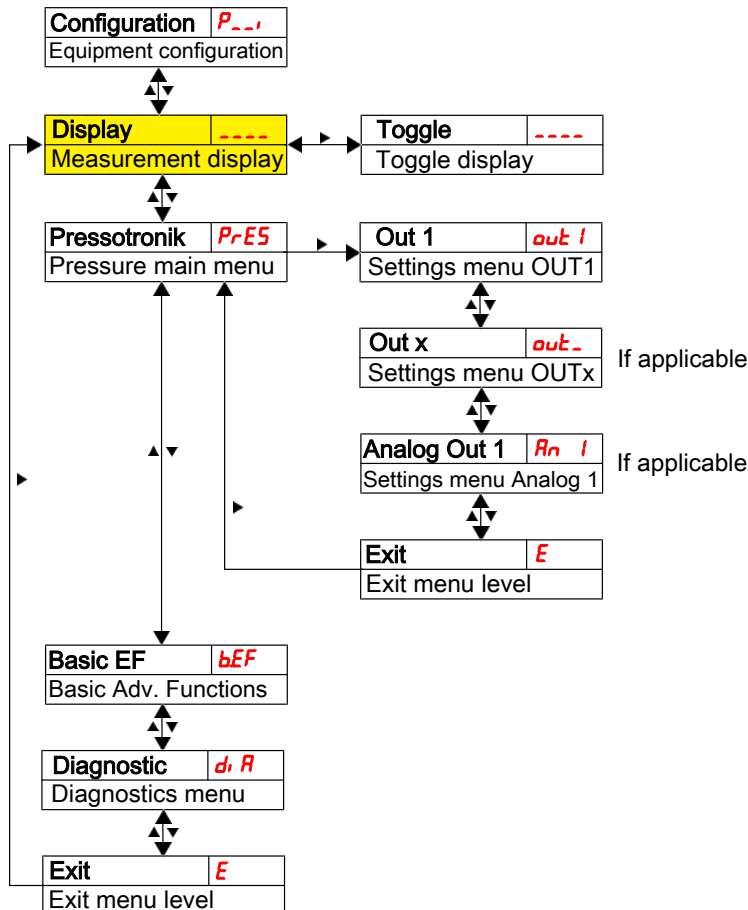

The individual menu items will not be shown if the option does not apply. Example: With a=0 the menu items for configuring the analogue output does not apply. You can then skip the description for this item.

The **Pressotronik** (*PrES*) main menu is used to configure the settings for the switching outputs or the Analogue outputs (if applicable).

The basic device settings can be changed. General settings can be configured under **Basic Settings Advanced Functions** (*bEF*). These settings should be configured first, as they affect the displays and settings for the individual menus. These settings are e.g. the units used.

The **Diagnostic** (*d, R*) menu further contains diagnostics options.

You will find the detailed illustration of the entire menu structure at the end of these instructions.

5.6 Changing basic settings

The general basic settings can be changed under menu **Basic Settings Extended Functions (bEF)**. These settings will affect the measurement display and the configuration options in the various main menus. Here you can also change the switching output assignment.

- Press the ▼ key to open the main menu.
- Select menu item (EF) using the ▼ and ▲ keys and open the menu with the ► key.

NOTICE



Disabling normal error handling

Disabling normal error handling and analysis could potentially cause dangerous operating states, dangers to the user or machines. Before using this option, review the hazard potential within the process. With this setting, Bühler Technologies GmbH assumes no liability for injuries to health or material damage caused by this setting.

5.6.1 Disabling normal error handling

Here you can enable/disable normal error handling and analysis.

The function Disable error handling (*Errh*) is used to disable normal error handling and analysis. This may pose dangers to the user or machine.

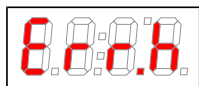
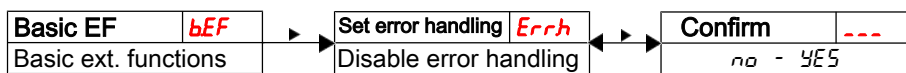

The options are:



Disables normal error handling.

Enables normal error handling (default)

Important note: When exceeding the measuring range or if sensor errors occur, the measurement will be frozen and all six LEDs in the status bar will blink. When the measurement returns to the permissible range the LEDs will stop blinking and the display will refresh again as usual.

5.6.2 Define switching outputs

Here you can define the switching outputs.

Use the “Define switching outputs” function to define the switching outputs (*rou1* and *rou2*). The switching outputs can also be defined as *Err* or *PrES*

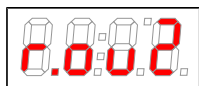
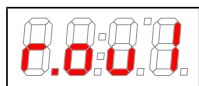
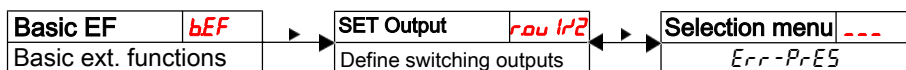

The options are:



Err



PrES

Note:

Options:

[*Err*, *PrES*]

- Switching outputs 1 and 2 can alternatively be wired as error indicators. In this case the output will be connected as a NC contact which opens when exceeding the range or if an error occurs. The LED assigned to this output will generally not be activated, as all 6 LEDs in the status bar will blink if an error occurs.
- When defining a switching output as an error indicator it will no longer be an option for normal switching output settings.

5.6.3 Changing the display direction

Here the display is rotated so it can be read when installing the sensor upside down:

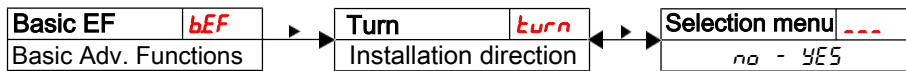

The options are:



Display remains upright, i.e. the delivery state.

Rotates the display 180°.

5.6.4 Setting the pressure unit

Used to set the unit symbol for the pressure:

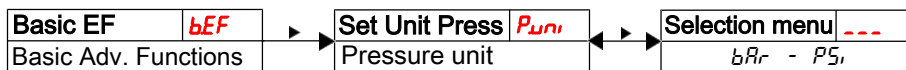

The options are:



Options:

[nbAr, bAr, MPa, PSi]

mbar

bar

MPa

psi

Note:

- nbAr can only be selected when max. pressure (P.Hi) <= 10 bar
- Values are automatically converted and the measuring range adjusted. However, always check the respective switching points and switch-back points.

5.6.5 Setting the maximum pressure

This is used to set the maximum pressure for the connected sensor:

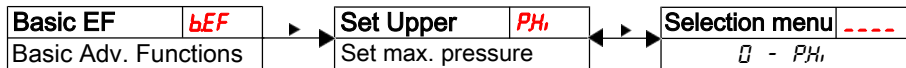

Assigning the maximum pressure:

Note:

- Values are automatically converted and the measuring range adjusted. However, always check the respective switching points and switch-back points.
- The minimum pressure will always be assumed to be 0 bar (0 psi).

5.6.6 Set display refresh rate

The refresh rate of the display can be changed based on the application. The display can also be completely disabled. The LEDs will remain functional.



The options are:



fast



medium



slow



Display off

Note:

- Error messages will still appear, even with the display off.

5.6.7 Enable/disable keylock

The keylock can be enabled to prevent unauthorised changes to the device settings.

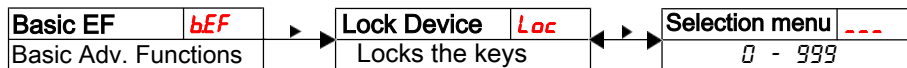

The keylock will be enabled after entering at least one digit > 0. A dot indicates the active digit during this input.



Setting range:
000 to 999

- Use the ▶ key to open the list of values:
- Enter the digit using the ▼ and ▲ keys (0 to 9) and press the ▶ key to confirm. The active digit will move one place to the right.
- Lastly, press the ▶ key to confirm the code. The device will now return to the submenu.

Note:

- To disable the keylock enter: 000

5.6.8 Restore factory settings (Reset)

Use the Reset function (*rES*) to restore the factory settings. All changes will be lost. Since this will also reset the limits, you must check the settings for the individual switching outputs.

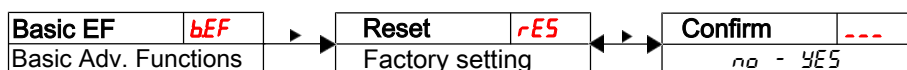

The options are:



Original status:
No,
keep current settings



Original status:
Yes,
reset settings to the factory defaults.

The factory settings are:

Definitions:

<i>SP X / rPX</i>	Switching point / switch-back point x
<i>dS X / drX</i>	Switch-on delay / switch-back delay for switching output x
<i>Rx.Hi / Rx.Lo</i>	Maximum and minimum measurement for output
<i>Pou X</i>	Analogue output signal type
<i>ou X</i>	Switching characteristic for switching output x
<i>Puni</i>	Pressure unit
<i>PHi</i>	Maximum pressure
<i>di S</i>	Display refresh rate
<i>Loc</i>	Keylock
<i>Suuu</i>	Switching output logged
<i>dPnn</i>	Delay for recording the minimum / maximum pressure

Note: For customer-specific specifications the factory preset may vary from those listed here.

Basic settings:

Basic Settings	
<i>Puni</i>	<i>bar</i>
<i>PHi</i>	<i>P[*]_{max}</i>
<i>di S</i>	<i>FAST</i>
<i>Loc</i>	<i>000</i>

* The maximum pressure P_{max}^* varies by the transmitter attached, see type plate.

Version with 1 switching output:

Switching outputs	
<i>SP 1 / rP 1</i>	<i>P[*]_{max} · 50 % / P[*]_{max} · 45 %</i>
<i>dS 1 / dr 1 / ou 1</i>	<i>0 / 0 / Hno</i>

* The maximum pressure P_{max} varies by the transmitter attached, see type plate.

Version with 2 switching outputs:

Switching outputs	
<i>SP 1 / rP 1</i>	<i>P[*]_{max} · 50 % / P[*]_{max} · 45 %</i>
<i>dS 1 / dr 1 / ou 1</i>	<i>0 / 0 / Hno</i>
<i>SP 2 / rP 2</i>	<i>P[*]_{max} · 60 % / P[*]_{max} · 55 %</i>
<i>dS 2 / dr 2 / ou 2</i>	<i>0 / 0 / Hno</i>

* The maximum pressure P_{max} varies by the transmitter attached, see type plate.

Version with 4 switching outputs:

Switching outputs	
<i>SP 1 / rP 1</i>	<i>P[*]_{max} · 50 % / P[*]_{max} · 45 %</i>
<i>dS 1 / dr 1 / ou 1</i>	<i>0 / 0 / Hno</i>
<i>SP 2 / rP 2</i>	<i>P[*]_{max} · 60 % / P[*]_{max} · 55 %</i>
<i>dS 2 / dr 2 / ou 2</i>	<i>0 / 0 / Hno</i>
<i>SP 3 / rP 3</i>	<i>P[*]_{max} · 70 % / P[*]_{max} · 65 %</i>
<i>dS 3 / dr 3 / ou 3</i>	<i>0 / 0 / Hno</i>
<i>SP 4 / rP 4</i>	<i>P[*]_{max} · 80 % / P[*]_{max} · 75 %</i>
<i>dS 4 / dr 4 / ou 4</i>	<i>0 / 0 / Hno</i>

* The maximum pressure P_{max} varies by the transmitter attached, see type plate.

Version with 6 switching outputs:

Switching outputs	
<i>SP1 / rP1</i>	$P_{max}^* \cdot 50 \% / P_{max}^* \cdot 45 \%$
<i>dS1 / dr1 / ou1</i>	<i>0 / 0 / Hno</i>
<i>SP2 / rP2</i>	$P_{max}^* \cdot 60 \% / P_{max}^* \cdot 55 \%$
<i>dS2 / dr2 / ou2</i>	<i>0 / 0 / Hno</i>
<i>SP3 / rP3</i>	$P_{max}^* \cdot 70 \% / P_{max}^* \cdot 65 \%$
<i>dS3 / dr3 / ou3</i>	<i>0 / 0 / Hno</i>
<i>SP4 / rP4</i>	$P_{max}^* \cdot 80 \% / P_{max}^* \cdot 75 \%$
<i>dS4 / dr4 / ou4</i>	<i>0 / 0 / Hno</i>
<i>SP5 / rP5</i>	$P_{max}^* \cdot 80 \% / P_{max}^* \cdot 75 \%$
<i>dS5 / dr5 / ou5</i>	<i>0 / 0 / Hno</i>
<i>SP6 / rP6</i>	$P_{max}^* \cdot 80 \% / P_{max}^* \cdot 75 \%$
<i>dS6 / dr6 / ou6</i>	<i>0 / 0 / Hno</i>

* The maximum pressure P_{max} varies by the transmitter attached, see type plate.

Version with analogue output:

Analogue output	
<i>RAH / RLo / Rdu1</i>	<i>0 / 100 / 1</i>

Diagnostic settings:

Diagnostics	
<i>Sduw</i>	<i>out1</i>
<i>Pnn</i>	<i>00</i>
<i>dPnn</i>	<i>0</i>

5.7 Switching outputs

All switching outputs are configured the same way. The switching output number is therefore represented by x. Open the switching output to be configured from the menu for the respective measured variable.

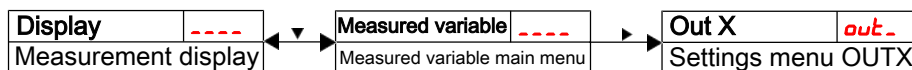

The switching output allocation and other basic settings related to all switching outputs can be configured in menu **Basic Settings Advanced Functions**.

Use submenu **Advanced Functions** to configure additional settings for each individual switching output which e.g. affect the switching characteristics of the output. The output can also be tested here.

5.7.1 Switching output x: Definition of the switching characteristic

The switching characteristic for the output can be configured under the following menu:

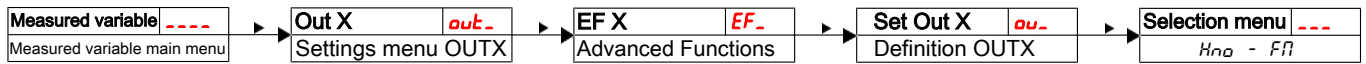

The options are:

Hysteresis Function

NO contact or NC contact function when the output signal is set when exceeding the configured switching point. The output signal will be deleted if the value is below the configured switch-back point.



Hysteresis function as the NO contact

Here, NO contact (H_{no}) means the PNP switching output is closed above switching point SP_x and opens below switching point rP_x .



Hysteresis function as the NC contact

Here, NC contact (H_{nc}) means the PNP switching output is open above switching point SP_x and closes below switching point rP_x .

Also see the explanation in the drawing below.

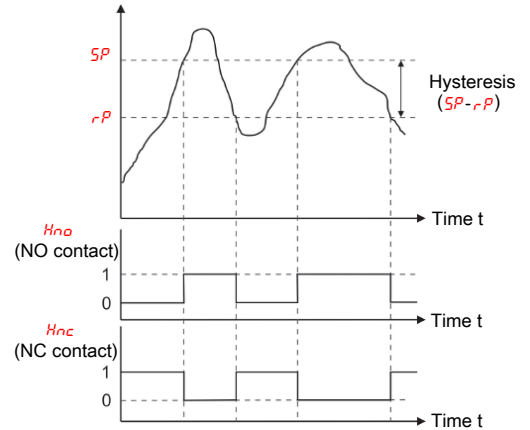

Window function

NO contact or NC contact function defining a signal window. When the measuring window is reached the output signal is set and deleted upon exiting.



Window function as NO contact

Here, NO contact (F_{no}) means the PNP switching output is closed if the value is within the window. Otherwise the switching output will be open.



Window function as NC contact

Here, NC contact (F_{nc}) means the PNP switching output is open if the value is within the window. Otherwise the switching output will be closed.

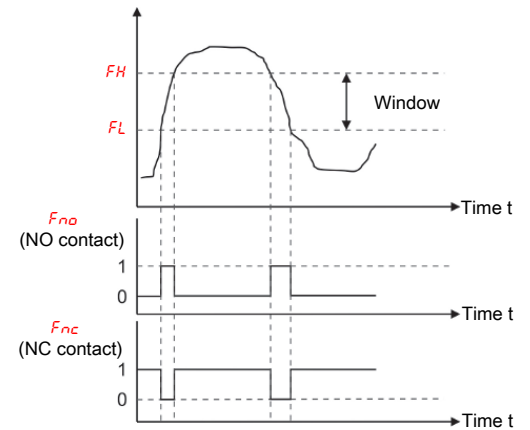

Frequency output

If the output is defined as a frequency output, a square wave signal with a frequency between 1 Hz and 100 Hz proportional to the measurement will be output.



Frequency output

Note: To increase the slew rate of the square wave signal, we recommend loading the switching output with an load of 10 kΩ.

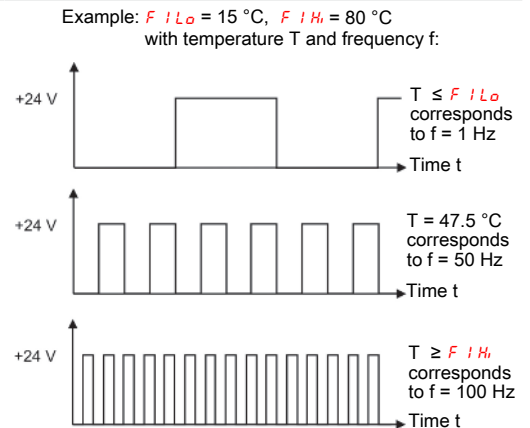

Note: The designation of the switching function may vary:

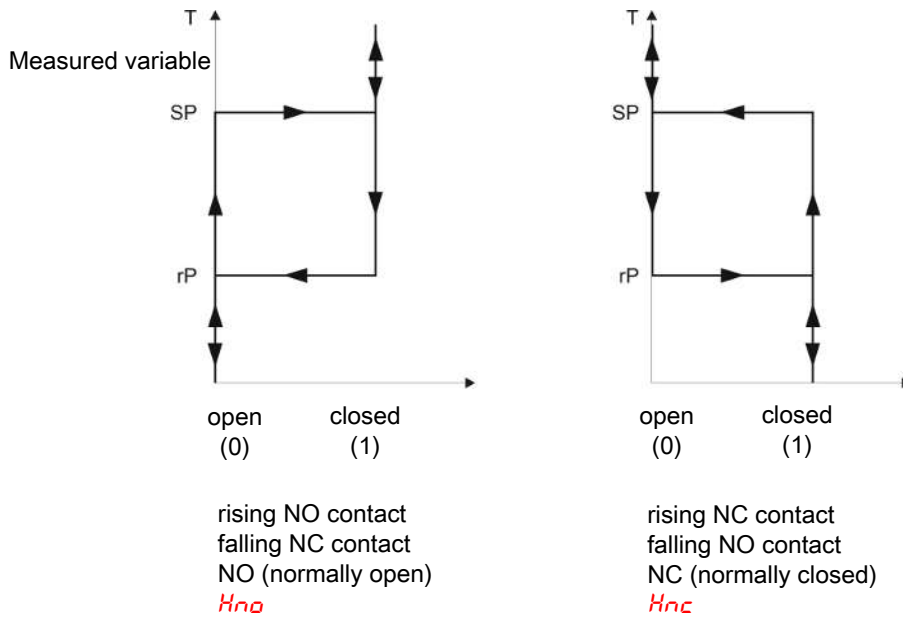

5.7.2 Switching output x: Upper switching limit (switching point)

The upper switching limit for switching output Out X can be defined with the following submenu:

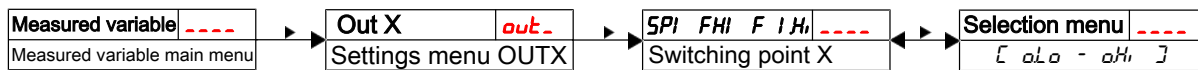

Switching point for OUT x

Note:

Setting range:
[0]...[PH]

- The switching point must be set to within the range limits (see menu **Basic Settings Advanced Functions**).
- If switching output OUT 1 was assigned the function **Window**, will appear. The setting corresponds with the upper window limit.
- If switching output OUT 1 was assigned the function **Frequency output**, will appear. The setting corresponds to the frequency 100 Hz.

5.7.3 Switching output x: Lower switching limit (switch-back point)

The lower switching limit for switching output Out 1 can be defined in the following submenu:

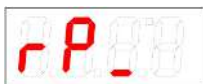
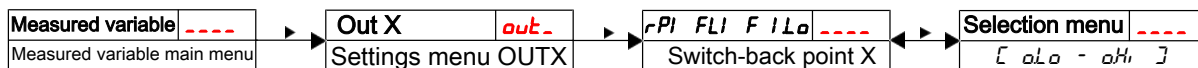

Switch-back point for OUT 1

Note:

Setting range:
[0]...[PH]

- The switch-back point must be set to within the range limits.
- If switching output OUT 1 was assigned the function **Window**, will appear. The setting corresponds with the lower window limit.
- If switching output OUT 1 was assigned the function **Frequency output**, will appear. The setting corresponds to the frequency 1 Hz.

5.7.4 Switching output x: Switch-on delay

The menu **Advanced Functions** *EFx* is used to configure additional settings for switching output x. The submenu is at the second submenu level.

The switching and switch-back delay prevents the alarm being triggered too frequently in unstable conditions. The switching delay can be configured with the following menu:

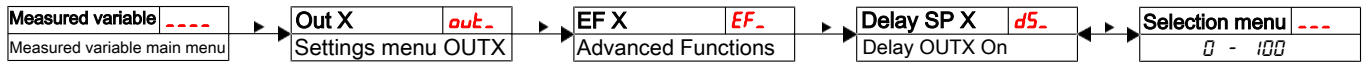

Time span in seconds during which the signal must be continuously present for the switching output to respond.

Note:

Setting range:
0...100 seconds

- If switching output OUT x was assigned the function **Window**, the setting corresponds to the switch-on delay which detects valid reaching of the measuring window.
- If switching output OUT x was assigned the function **Frequency output**, this value will have no affect.

5.7.5 Switching output x: Switch-back delay

The switch-back delay can be configured with the following menu:

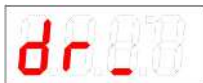
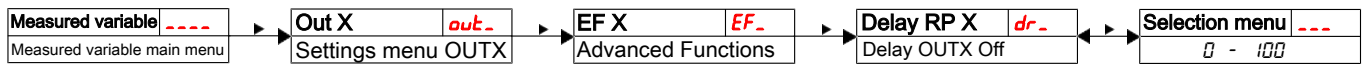

Switch-back signal delay for OUT x.

Time span in seconds during which the signal must be continuously present for the switching output to respond.

Note:

Setting range:
0...100 seconds

- If switching output OUT x was assigned the function **Window**, the setting corresponds to the switch-on delay which detects valid closing of the measuring window.
- If switching output OUT x was assigned the function **Frequency output**, this value will have no affect.

5.7.6 Switching output x: Testing the switching output

The switching output test can be started with the following menu:

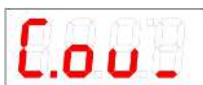
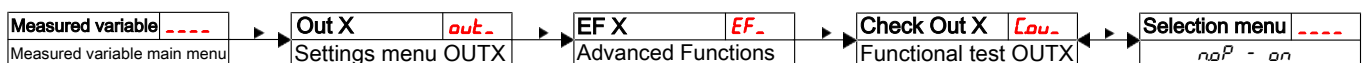

Switching output test option

Options when setting *ou 1* to *Hno* / *Hnc* / *Fno* / *Fnc*:



Normal switching output operation

Switching output permanently off disabled

Switching output permanently activated

Options when setting *ou 1* to *F?:*



Normal mode as frequency output

Output Frequency 1 Hz

Output Frequency 100 Hz



Note:

- **After completing the test, set the function to normal mode *noP*.**



1800-OILSOL
1800-645765

<https://oilsolutions.com.au/>

sales@oilsolutions.com.au

5.7.7 Change status LED display function

The LEDs in the display indicate the switching status of the output. The following table shows how LEDs are allocated to the switching output:

Numbering LED	Switching output x	Assignment for 2 switching outputs	Assignment for 4 switching outputs	Assignment for 6 switching outputs
LED	1	LED 1 - yellow	LED 1 - yellow	LED 1 - yellow
1 2 3 4 5 6	2	LED 2 - red	LED 2 - red	LED 2 - red
	3		LED 3 - yellow	LED 3 - yellow
	4		LED 4 - red	LED 4 - red
	5			LED 5 - yellow
	6			LED 6 - red

In the factory setting the LED indicates the physical status of the PNP switching output (switching output closed – LED on).

The logical indicator function may need to be different from the physical signal on the switching output. You can therefore also reverse this indication with this menu (switching output open – LED on).







Example:

You have 2 switching outputs for the pressure, configured as:

- **Switching output 1:** Max. contact, rising NO contact. The LED lights up when the maximum value is exceeded and the pressure is above the desired range. So this LED lighting up indicates an "Error" status.
- **Switching output 2:** Min contact, rising NO contact. So in the factory setting, the LED lights up when exceeding the minimum pressure. So in this case the LED would light up if the status is okay.

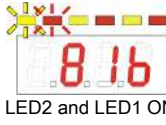
The table shows an example with the factory setting and with inverted status function for LED1. The switching points are defined as:

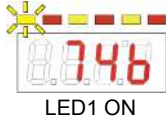
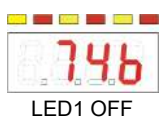
SP1 = 70 bar, rP1 = 65 bar
 SP2 = 80 bar, rP2 = 75 bar

	Factory setting	Status function LED 1 inverted	State	Status
A	 LED1 ON	 LED1 OFF	Pressure rises to > 70 bar PNP switching output 1 closed	OK
B	 LED2 and LED1 ON	 only LED2 ON	Pressure rises to > 80 bar PNP switching output 2 closed	Error
C	 LED1 ON	 LED1 OFF	Pressure falls to < 75 bar PNP switching output 2 open	OK
D	 LED1 OFF	 LED1 ON	Pressure falls to < 65 bar PNP switching output 1 open	Error

Here you can reverse the LED status function for a contact: the LED lights up if the contact is open, so below the minimum pressure, and the LED lighting up again indicates an "Error" status.



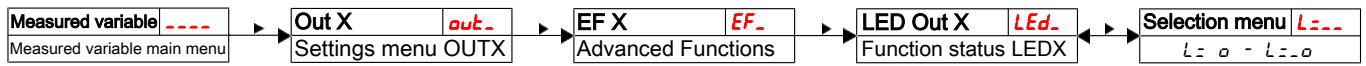

The options are:



LED = output;

the LED lights up when the PNP switching output is closed.

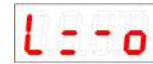

LED = - output;

the LED lights up when the PNP switching output is open.

NOTICE



The display function of the status LED affects event logging! Please note chapter “Diagnostic options”.

5.8 Analogue outputs

5.8.1 Analogue output x: Assigning the upper limit

Used to configure at which pressure to output the maximum analogue signal. This is configured in menu:

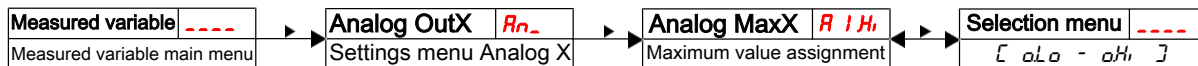

Note:

- The output range setting must not be less than 10 % of the measuring range: $A.Hi - A.Lo >= 10\% * (aHi - aLo)$
- If the range is set too low, the analogue value output may have grades.

Setting range:
[aLo] ... [aHi]

5.8.2 Analogue output x: Lower limit assignment

Used to configure at which pressure to output the minimum analogue signal. This is configured in menu:

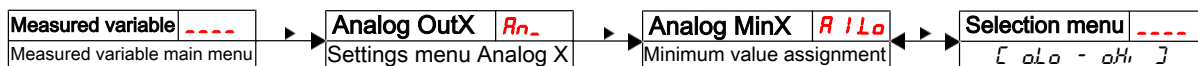

Note:

- The output range setting must not be less than 10 % of the measuring range: $A.Hi - A.Lo >= 10\% * (aHi - aLo)$
- If the range is set too low, the analogue value output may have grades.

Setting range:
[aLo] ... [aHi]

5.8.3 Analogue output x: Signal type assignment

The analogue output can be defined as a voltage or current output with different value ranges. This is configured in menu:

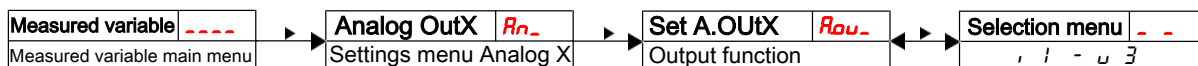

The options are:



4 mA to 20 mA



2 V to 10 V



0 V to 10 V



0 V to 5 V



1800-OILSOL
1800-645765

<https://oilsolutions.com.au/>

sales@oilsolutions.com.au

5.8.4 Analogue output x: Testing the analogue output

The analogue output can be tested. The highest, mean and lowest analogue value can be output successively. This is configured in menu:

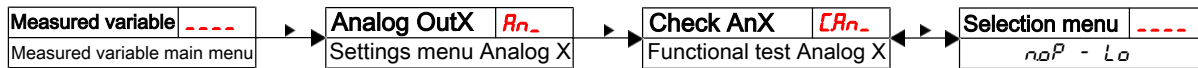

The options are:



Normal mode



Highest analogue value output



Mean analogue value output



Lowest analogue value output



Note:

- After completing the test, set the function to normal mode **noP**.

5.9 Diagnostic options

The device is able to log events for a switching output. The LED lighting up is considered an event. The logging of switching procedures therefore depends on how the LED switching function is configured.

The configuration and analysis can be carried out here.

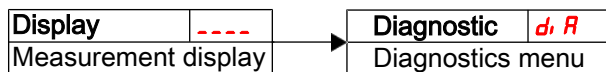

NOTICE



Only one switching output can be logged. The switching output to be logged is configured in menu item **Set Journal Out** (*Subou*).

- Press the ▼ key to open the main menu.
- Select menu item *d_ R* with the ▼ and ▲ keys.



From here you will be able to access various diagnostic values and measurement monitoring logs.

- Open the menu with the ► key.
You can now change or view the diagnostic settings.

5.9.1 View logbook

The last 6 events for the switching output being logged can be viewed here and all entries deleted:

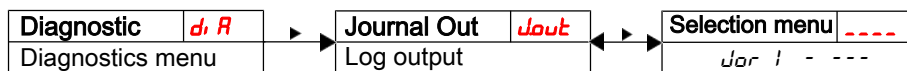

The journal entries will be displayed as:

- Most recent event *Jor 1* occurred x hours (h) / days (d) ago,
- Events 2 to 5 occurred x hours / days ago,
- The oldest event *Jor 6* occurred x hours / days ago,
- Delete function (---)

Example:

Jor 1 ⇔ 13h, key ▼
Jor 2 ⇔ 24h, key ▼, ▲
Jor 3 ⇔ 6.1h, key ▼, ▲
Jor 4 ⇔ 82h, key ▼, ▲
Jor 5 ⇔ non B, key ▼, ▲, ▲
Jor 6 ⇔ non B, key ▼, ▲, ▲
 ---, key ▲; ► = delete

* not yet populated, only 4 events have occurred



1800-OILSOL
1800-645765

<https://oilsolutions.com.au/>

sales@oilsolutions.com.au



The information displayed will alternate between the index and time for entry x, e.g. *Jor 1* ↔ *1.4h* for the most recent event 1.4 hours ago.

Press the **▶** key to return to the submenu or use **▼**, **▲** to select the next journal entry.

Confirming the information with the **▶** key will delete the list of events and return to the submenu.

Note:

- If no events have been logged, the display will alternate between *Jor X* and *nan*.

5.9.2 Maximum and minimum pressure

Used to view or delete the saved maximum and minimum pressure:

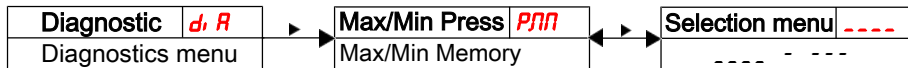

The journal entries will be displayed as:

- Maximum pressure value,
- occurred x hours / days ago,
- Minimum pressure value,
- occurred x hours / days ago,
- Delete function

Example:

75b, Key **▼**
8.4h, key **▼**, **▲**
1.7b, key **▼**, **▲**
2.1h, key **▼**, **▲**
 ---, key **▲**; **▶** = delete

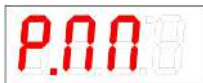

Press the **▶** key to return to the submenu or use **▼**, **▲** to select the next Journal entry.

Confirming the information with the **▶** key will delete the list of events and return to the submenu.

- Menu order:
- Max. value,
 - min.
 - time value
 - time
 - delete (reset)

5.9.3 Define switching output to log

Used to select the switching output to be logged. Only one switching output can be logged.

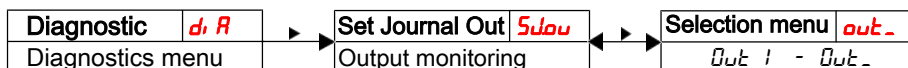

Switching output logging.

- Options:
- out 1* to *out X*

NOTICE



Values are backed up from volatile to non-volatile memory approx. every three hours.



5.9.4 Delay for storing the Min/Max pressure

A delay time for saving the minimum and maximum pressure can be set to record reliable values when the pressure fluctuates. Here, enter the time span in seconds during which the signal must be continuously present before the pressure is logged.

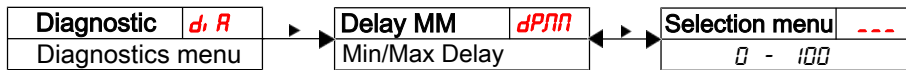

– Set the desired delay.

Setting range:
0...100 seconds

6 Cleaning and Maintenance

This device is maintenance-free.

The method for cleaning the devices must be adapted to the IP protection class of the devices. Do not use cleaners which could damage the device materials.



1800-OILSOL
1800-645765

<https://oilsolutions.com.au/>

sales@oilsolutions.com.au

7 Service and repair

This chapter contains information on troubleshooting and correction should an error occur during operation.

Repairs to the unit must be performed by Bühler authorised personnel.

Please contact our Service Department with any questions:

Tel.: +49-(0)2102-498955 or your agent

If the equipment is not functioning properly after correcting any malfunctions and switching on the power, it must be inspected by the manufacturer. Please send the equipment inside suitable packaging to:

Bühler Technologies GmbH

- Reparatur/Service -

Harkortstraße 29

40880 Ratingen







Germany

Please also attach the completed and signed RMA decontamination statement to the packaging. We will otherwise be unable to process your repair order.

You will find the form in the appendix of these instructions, or simply request it by e-mail:

service@buehler-technologies.com.

7.1 Troubleshooting

Problem / Malfunction	Possible cause	Action
No display	– No supply voltage	– Check cable and replace, if necessary
Error messages on the display:		
Alternating between Err and Exxx: e.g.  ↔ 		
 Error 001	– Ambient temperature too low	– Maintain limits
 Error 002	– Ambient temperature too high	– Maintain limits
 Error 064	– Cable brake or defective transmitter	– Replace transmitter and/or cable
 Error 128	– Transmitter defective	– Replace transmitter
	– Measuring range exceeded	– Check the system and transmitter, maintain the max. pressure
 Error 1024	– Second plug has no supply voltage	– Check the supply voltage for the second plug. – Be sure to switch on or plug in the power supply for the second plug before or shortly after the first.
	– Internal error	– Please contact customer service

Possible errors

Problem / Malfunction	Possible cause	Action
Switching output not triggered when exceeding limits	– Switching output configured incorrectly	– In submenu LOUx : “Test Switching Output” to ensure normal mode
	– Switching output defect	– In submenu LOUx : “Test Switching Output” to test the desired switching output
Switching output constantly switching	– Switching output configured incorrectly	– In submenu LOUx : “Test Switching Output” to ensure normal mode
	– Switching output defect	– In submenu LOUx : “Test Switching Output” to test the desired switching output
The analogue doesn't receive the full/correct output current	– Wrong signal type set	– In submenu ROUx : Check and if necessary set the correct signal type (current/voltage output)
	– Load too high (current output)	– Reduce load to permissible value
Analogue output doesn't change the output signal when the input signal changes	– Analogue output configured incorrectly	– In submenu LOUx : „Test Analogue Output“ to ensure normal mode

7.2 Spare parts and accessories

Pressotronic 700 - Transmitter only

Item no.	Description	Pressure range
137000100	PT700-010	0 - 10 bar
137000250	PT700-025	0 - 25 bar
137001000	PT700-100	0 - 100 bar
137002500	PT700-250	0 - 250 bar
137004000	PT700-400	0 - 400 bar
137006000	PT700-600	0 - 600 bar

Pressotronic 700

Accessories

Item no.	Description
9144 05 0010	Connecting cable M12x1, 4-pin, 1.5 m, angular coupling and straight plug
9144 05 0046	Connecting cable M12x1, 4-pin, 3.0 m, angular coupling and straight plug
9144 05 0047	Connecting cable M12x1, 4-pin, 5.0 m, angular coupling and strands

Pressotronic 770/771

Item no. 4-pin	Item no. 5-pin	Item no. 8-pin	Description
9144 05 0010	9144 05 0016	9144 05 0048	Connecting cable M12x1, 1.5 m, angular coupling and straight plug
9144 05 0046	9144 05 0017	9144 05 0049	Connecting cable M12x1, 3.0 m, angular coupling and straight plug
9144 05 0047	9144 05 0018	9144 05 0033	Connecting cable M12x1, 5.0 m, angular coupling and strands



8 Disposal

Dispose of parts so as not to endanger the health or environment. Follow the laws in the country of use for disposing of electronic components and devices during disposal.



1800-OILSOL
1800-645765

<https://oilsolutions.com.au/>

sales@oilsolutions.com.au

9 Appendices

9.1 Technical Data Pressotronik 700

Pressure transmitter

	Pressure range	Dimensions Pressotronik 700		
	0 - 10 bar 0 - 25 bar 0 - 100 bar 0 - 250 bar 0 - 400 bar 0 - 600 bar			
	Other pressure ranges available upon request			
Pressure connection	G1/4 external thread, DIN 3852 Form E; peak pressure aperture standard for 100 bar and higher			
Overload higher values available upon request	2.5 x full range at 10 to 600 bar (but max. 900 bar)			
Burst pressure	2.5 x full range at 6 to 600 bar (but max. 900 bar)			
Higher burst pressure available upon request	Patented medium stop system to prevent medium leaks when exceeding the bursting pressure range (>40 bar rated pressure)			
Material / version				
Housing	1.4305			
Material in contact with media	Ceramic, 1.4305, PPS, FPM			
Weight	approx. 95 g			
Temperature				
Medium	-15 °C to + 125 °C			
Ambient temperature	max. 85 °C			
Temperature influences	Within - 40 to +125 °C temperature range			
	Calibration in bar	Calibration in psi		
TC0 - Temperature zero error	< ±0.15 % FS/10 K	< ±0.25 % FS/10 K		
TCE - Temperature full range error	< ±0.15 % FS/10 K	< ±0.15 % FS/10 K		
Response time	< 2 ms / typically 1 ms			
Electrical data		Standard pin assignment Pressotronik 700		
Supply voltage (U _B)	10 – 30 V DC (nominal voltage 24 V DC)	Plug: 1xM12x1		
Degree of protection	IP67	Pin		
Burden Ω	= (U _B -8 V) / 0.02 A	1		+24 V DC
Dielectric strength	500 V DC	3		4-20 mA

Accuracy

Parameter	Unit
Tolerance zero	max. ± 0.3 % FS
Tolerance full range	max. ± 0.3 % FS
Resolution	0.1 % FS
Sum of linearity, hysteresis and reproducibility	max. ± 0.3 % FS/10K
Long-term stability per DIN EN 60770	± 1 % FS
TC zero	max. ± 0.15 % FS/10K
TC sensitivity	max. ± 0.15 % FS/10K

Test conditions: 25 °C, 45 % rF, supply 24 V DC, K0/TCE -40 °C... +125 °C



1800-OILSOL
1800-645765

<https://oilsolutions.com.au/>

sales@oilsolutions.com.au

9.2 Technical Data Pressotronik 770

Remote display version (PT700 pressure transmitter must be ordered separately)

For pressure transmitter	Pressotronik 700
Control unit	
Version	
Housing material	PA
Mount	35 mm top-hat rail mounting
Weight	approx. 400 g
Degree of protection	IP65
Analysis display electronics	
Display	4 character 7 segment LED display
Operation	via 3 keys
Starting current input	approx. 100 mA for 100 ms
Power input during operation	approx. 50 mA
Supply voltage (U_B)	10 - 30 V DC (nominal voltage 24 V DC)
Ambient temperature	-20 °C to +70 °C
Accuracy	± 1 % from end value
Input values	
Display units	b (bar), P (psi), °MPa
Input signal	4-20 mA

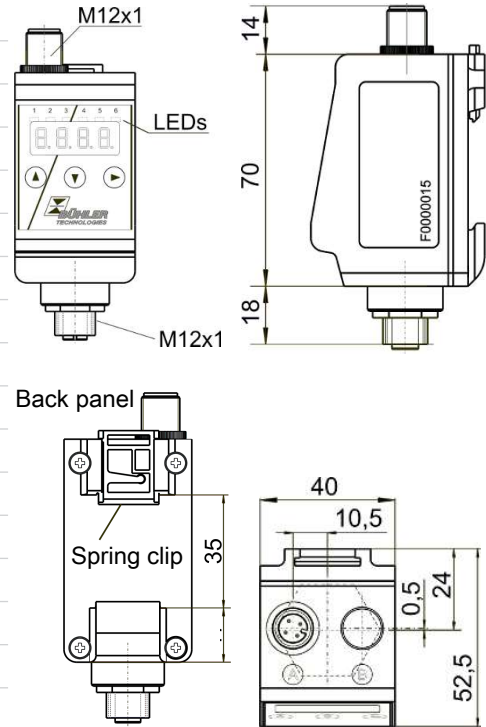

Optional switching outputs

	-1D1S	-2S	-4S	-6S
Plug (base)	1 x M12 – 4-pin	1 x M12 – 4-pin	1 x M12 – 8-pin	1 x M12 – 8-pin
Plug (jack)	1 x M12 – 4-pin	1 x M12 – 4-pin	1 x M12 – 4-pin	1 x M12 – 4-pin
Switching outputs	IO-Link and 1x freely programmable	2 x freely programmable	4 x freely programmable	6 x freely programmable
Alarm memory	with 1 x assignable to alarm logbook	with 1 x assignable to alarm logbook	with 1 x assignable to alarm logbook	with 1 x assignable to alarm logbook
max. switching current	0.5 A per output*	0.5 A per output*	0.5 A per output*	0.5 A per output*
Contact load	max. 1 A total	max. 1 A total	max. 1 A total	max. 1 A total

*Output 1 max. 0.2 A.

	-1S-K	-2S-K	-4S-K
Plug (base)	1 x M12 – 4-pin	1 x M12 – 5-pin	1 x M12 – 8-pin
Plug (jack)	1 x M12 – 4-pin	1 x M12 – 4-pin	1 x M12 – 4-pin
Switching outputs	1 x freely programmable	2 x freely programmable	4 x freely programmable
Alarm memory	with 1 x assignable to alarm logbook	with 1 x assignable to alarm logbook	with 1 x assignable to alarm logbook
max. switching current	0.5 A per output*	0.5 A per output*	0.5 A per output*
Contact load	max. 1 A total	max. 1 A total	max. 1 A total
Analogue outputs	1 x pressure	1 x pressure	1 x pressure
Programmable as	1 x 4 – 20 mA 2 – 10 V DC, 0 – 10 V DC, 0 – 5 V DC	1 x 4 – 20 mA 2 – 10 V DC, 0 – 10 V DC, 0 – 5 V DC	1 x 4 – 20 mA 2 – 10 V DC, 0 – 10 V DC, 0 – 5 V DC
max. load Ω as current output	$(U_B - 8V) / 0.02 A$	$(U_B - 8V) / 0.02 A$	$(U_B - 8V) / 0.02 A$
min. input load as voltage input	10 k Ω	10 k Ω	10 k Ω

*Output 1 max. 0.2 A.

9.3 Technical Data Pressotronik 771

Version with attached transmitter

Pressure transmitter	Pressotronik 700
Control unit	Version
Housing material	PA
Mount	G1/4 directly mounted display rotates 270°
Weight	approx. 500 g
Degree of protection	IP65
Display electronics	
Display	4 character 7 segment LED display
Control	via 3 keys
Starting current input	approx. 100 mA for 100 ms
Power input during operation	approx. 50 mA
Supply voltage (U _B)	10 - 30 V DC (nominal voltage 24 V DC)
Ambient temperature	-20 °C to +70 °C
Accuracy	± 1% from full range
Input values	
Display units	b (bar), P (psi), °MPa

Housing swivels 270 °C

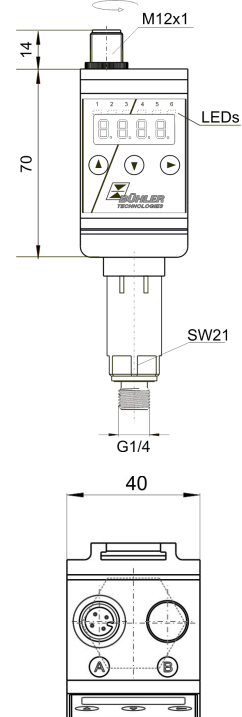

Optional switching outputs	-1D1S	-2S	-4S
Plug (base)	1 x M12 – 4-pin	1 x M12 – 4-pin	1 x M12 – 8-pin
Switching outputs	IO-Link and 1x freely programmable	2 x freely programmable*	4 x freely programmable*
Alarm memory	with 1 x assignable to alarm logbook	with 1 x assignable to alarm logbook	with 1 x assignable to alarm logbook
max. Switching current	0.5 A per output**	0.5 A per output**	0.5 A per output**
Contact load	max. 1 A total	max. 1 A total	max. 1 A total

*also programmable as frequency output.

**Output 1 max. 0.2 A.

	-1S-K	-2S-K	-4S-K
Plug (base)	1 x M12 – 4-pin	1 x M12 – 5-pin	1 x M12 – 8-pin
Switching outputs	1 x freely programmable	2 x freely programmable	4 x freely programmable
Alarm memory	with 1 x assignable to alarm logbook	with 1 x assignable to alarm logbook	with 1 x assignable to alarm logbook
max. Switching current	0.5 A per output*	0.5 A per output*	0.5 A per output*
Contact load	max. 1 A total	max. 1 A total	max. 1 A total
Analogue outputs	1 x pressure	1 x pressure	1 x pressure
Programmable as	1 x 4 – 20 mA 2 – 10 V DC, 0 – 10 V DC, 0 – 5 V DC	1 x 4 – 20 mA 2 – 10 V DC, 0 – 10 V DC, 0 – 5 V DC	1 x 4 – 20 mA 2 – 10 V DC, 0 – 10 V DC, 0 – 5 V DC
max. load Ω as current output	(U _B – 8V) / 0.02 A	(U _B – 8V) / 0.02 A	(U _B – 8V) / 0.02 A
min. input load as voltage input	10 kΩ	10 kΩ	10 kΩ

*Output 1 max. 0.2 A.



9.4 Standard pin assignment Pressotronik 770

Pin assignment Pressotronik 770

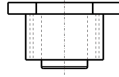
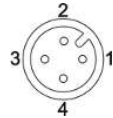
For the pressure transmitter assignment, see **Pressotronik 700 standard pin assignment**

Panel jack	1x M12x1 4-pin
	
Panel jack	
Pin	
1	+24 V DC
3 / 4	4 - 20 mA

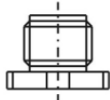
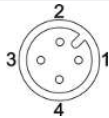
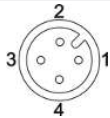
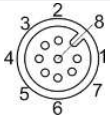
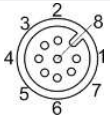
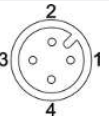
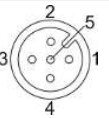
9.5 Standard pin assignment Pressotronik 770 and 771

Version	-1D1S	-2S	-4S	-6S	-1S-K	-2S-K	-4S-K
Panel plug	4-pin	4-pin	8-pin	8-pin	4-pin	5-pin	8-pin
				1x M12x1 			
Panel plug							
Pin							
1	+24 V DC	+24 V DC	+24 V DC	+24 V DC	+24 V DC	+24 V DC	+24 V DC
2	S2 (PNP)	S2 (PNP)	S2 (PNP)	S2 (PNP)	Analogue (out)	S2 (PNP)	S2 (PNP)
3	GND	GND	GND	GND	GND	GND	GND
4	C/Q (IO-Link)	S1 (PNP)	S1 (PNP)	S1 (PNP)	S1 (PNP)	S1 (PNP)	S1 (PNP)
5			S3 (PNP)	S3 (PNP)		Analogue (out)	S3 (PNP)
6			S4 (PNP)	S4 (PNP)			S4 (PNP)
7				S5 (PNP)			Analogue (out)
8				S6 (PNP)			

9.6 Current settings

Switching outputs	Basic Settings	Diagnostics
SP1 / rP1	oun1	Sduu
dS1 / dr1 / ou1	Pun1	dPnn
SP2 / rP2	PH1	
dS2 / dr2 / ou2	di S	
SP3 / rP3	Loc	
dS3 / dr3 / ou3		
SP4 / rP4		
dS4 / dr4 / ou4		
SP5 / rP5		
dS5 / dr5 / ou5		
SP6 / rP6		
dS6 / dr6 / ou6		
Analogue outputs		
R1Hi / R1Lo / Rou1		
R2Hi / R2Lo / Rou2		

Date: _____

Signature: _____

9.7 Display ranges

Name	Menu/Unit	Display	Range from/ with unit	Range to/ with unit
Pressure				
Bar	bBr	b	-100 bar	999 bar
mBar	mbBr	none	-1000	9999
Mpa	nPR	P	-10.0 Mpa	99.9 Mpa
psi	PSi	none	-1000	9999
N/A				
none	non	none	-1000	9999
none	non1	none	-100.0	999.9
none	non2	none	-10.00	99.99

9.8 Display resolution

Range x = |Max - Min|

none (non), psi, mBar (no decimal places)		Mpa (up to 2 decimal places)	
Range x	Resolution	Range x	Resolution
x < 500	1	x < 5	0.01
500 <= x < 1000	2	5 <= x < 10	0.02
1000 <= x < 2000	5	10 <= x < 20	0.05
2000 <= x < 5000	10	20 <= x < 50	0.1
5000 <= x < 10000	20	50 <= x < 100	0.2
10000 <= x	50	100 <= x	0.5



1800-OILSOL
1800-645765

<https://oilsolutions.com.au/>

sales@oilsolutions.com.au

none (<i>non 1</i>) (1 fixed-point number)		none (<i>non 2</i>) (2 fixed-point numbers)	
Range x	Resolution	Range x	Resolution
x < 50	0.1	x < 5	0.01
50 <= x < 100	0.2	5 <= x < 10	0.02
100 <= x < 200	0.5	10 <= x < 20	0.05
200 <= x < 500	1	20 <= x < 50	0.1
500 <= x < 1000	2	50 <= x < 100	0.2
1000 <= x	5	100 <= x	0.5

Example no unit: Min = 100, Max = 1500 -> x = 1500 - 100 = 1400 -> Resolution = 5



9.9 Menu Sequence Overview

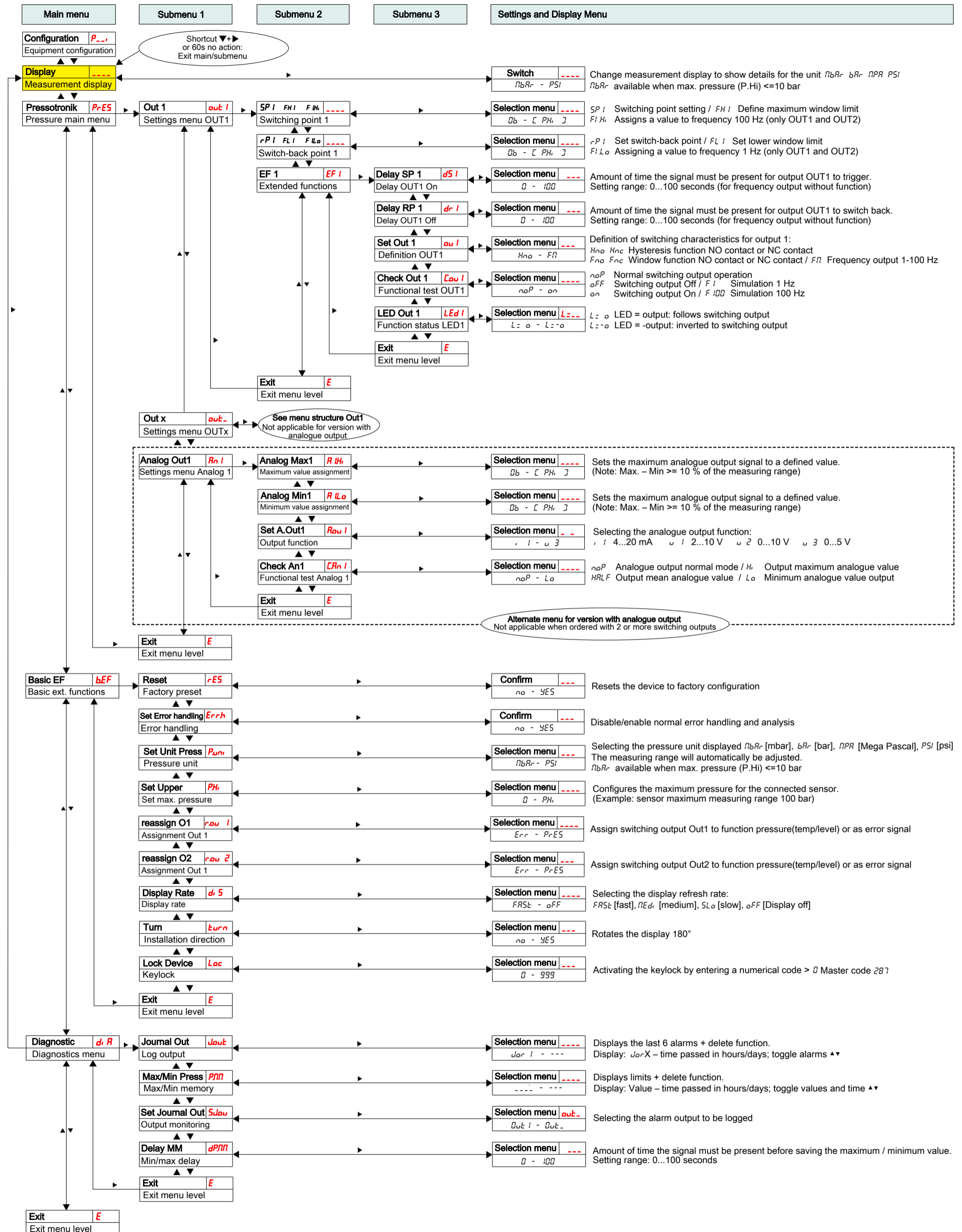

10 Attached documents

- Declaration of conformity: KX130022
- RMA - Decontamination Statement



1800-OILSOL
1800-645765

<https://oilsolutions.com.au/>

sales@oilsolutions.com.au

EU-Konformitätserklärung
EU-declaration of conformity



Hiermit erklärt Bühler Technologies GmbH,
dass die nachfolgenden Produkte den
wesentlichen Anforderungen der Richtlinie

*Herewith declares Bühler Technologies GmbH
that the following products correspond to the
essential requirements of Directive*

2014/30/EU

(Elektromagnetische Verträglichkeit / *electromagnetic compatibility*)

in ihrer aktuellen Fassung entsprechen.

in its actual version.

Produkt / products: Elektronische Druckschalter und – fähler /
Electronic pressure switches and sensors

Typ / type: Pressotronik 77

Die Betriebsmittel sind ein Drucksensor bzw. Druckschalter zur Anzeige und Steuerung des Druckes in
einem Fluidsystem.

*The equipment is a pressure sensor respectively pressure switch to control and display the pressure in a
fluid system.*

Das oben beschriebene Produkt der Erklärung erfüllt die einschlägigen
Harmonisierungsrechtsvorschriften der Union:

*The object of the declaration described above is in conformity with the relevant Union harmonisation
legislation:*

EN 61326-1:2013

Die alleinige Verantwortung für die Ausstellung dieser Konformitätserklärung trägt der Hersteller.
This declaration of conformity is issued under the sole responsibility of the manufacturer.

Dokumentationsverantwortlicher für diese Konformitätserklärung ist Herr Stefan Eschweiler mit
Anschrift am Firmensitz.

*The person authorised to compile the technical file is Mr. Stefan Eschweiler located at the company's
address.*

Ratingen, den 20.04.2016

Stefan Eschweiler
Geschäftsführer – *Managing Director*

Frank Pospiech
Geschäftsführer – *Managing Director*

KX 13 0022

Bühler Technologies GmbH, Harkortstr. 29, D-40880 Ratingen,
Tel. +49 (0) 21 02 / 49 89-0, Fax. +49 (0) 21 02 / 49 89-20
Internet: www.buehler-technologies.com



1800-OILSOL
1800-645765

<https://oilsolutions.com.au/>

sales@oilsolutions.com.au

RMA-Formular und Erklärung über Dekontaminierung

RMA-Form and explanation for decontamination



RMA-Nr./ RMA-No.

Die RMA-Nummer bekommen Sie von Ihrem Ansprechpartner im Vertrieb oder Service./ You may obtain the RMA number from your sales or service representative.

Zu diesem Rücksendeschein gehört eine Dekontaminierungserklärung. Die gesetzlichen Vorschriften schreiben vor, dass Sie uns diese Dekontaminierungserklärung ausgefüllt und unterschrieben zurücksenden müssen. Bitte füllen Sie auch diese im Sinne der Gesundheit unserer Mitarbeiter vollständig aus./ This return form includes a decontamination statement. The law requires you to submit this completed and signed decontamination statement to us. Please complete the entire form, also in the interest of our employee health.

Firma/ Company

Firma/ Company
Straße/ Street
PLZ, Ort/ Zip, City
Land/ Country

Ansprechpartner/ Person in charge

Name/ Name
Abt./ Dept.
Tel./ Phone
E-Mail
Serien-Nr./ Serial No.
Artikel-Nr./ Item No.

Gerät/ Device
Anzahl/ Quantity
Auftragsnr./ Order No.

Grund der Rücksendung/ Reason for return

- Kalibrierung/ Calibration Modifikation/ Modification
 Reklamation/ Claim Reparatur/ Repair
 andere/ other

bitte spezifizieren/ please specify

Ist das Gerät möglicherweise kontaminiert?/ Could the equipment be contaminated?

- Nein, da das Gerät nicht mit gesundheitsgefährdenden Stoffen betrieben wurde./ No, because the device was not operated with hazardous substances.
 Nein, da das Gerät ordnungsgemäß gereinigt und dekontaminiert wurde./ No, because the device has been properly cleaned and decontaminated.
 Ja, kontaminiert mit:/ Yes, contaminated with:



explosiv/
explosive



entzündlich/
flammable



brandfördernd/
oxidizing



komprimierte
Gase/
compressed
gases



ätzend/
caustic



giftig,
Lebensgefahr/
poisonous, risk
of death



gesundheitsge-
fährdend/
harmful to
health



gesund-
heitsschädlich/
health hazard



umweltge-
fährdend/
environmental
hazard

Bitte Sicherheitsdatenblatt beilegen!/ Please enclose safety data sheet!

Das Gerät wurde gespült mit:/ The equipment was purged with:

Diese Erklärung wurde korrekt und vollständig ausgefüllt und von einer dazu befugten Person unterschrieben. Der Versand der (dekontaminierten) Geräte und Komponenten erfolgt gemäß den gesetzlichen Bestimmungen.

This declaration has been filled out correctly and completely, and signed by an authorized person. The dispatch of the (decontaminated) devices and components takes place according to the legal regulations.

Falls die Ware nicht gereinigt, also kontaminiert bei uns eintrifft, muss die Firma Bühler sich vorbehalten, diese durch einen externen Dienstleister reinigen zu lassen und Ihnen dies in Rechnung zu stellen.

Should the goods not arrive clean, but contaminated, Bühler reserves the right, to commission an external service provider to clean the goods and invoice it to your account.

Firmenstempel/ Company Sign

Datum/ Date

Bühler Technologies GmbH, Harkortstr. 29, D-40880 Ratingen
Tel. +49 (0) 21 02 / 49 89-0, Fax: +49 (0) 21 02 / 49 89-20
E-Mail: service@buehler-technologies.com
Internet: www.buehler-technologies.com

rechtsverbindliche Unterschrift/ Legally binding signature

DE000011
01/2019



1800-OILSOL
1800-645765

<https://oilsolutions.com.au/>

sales@oilsolutions.com.au



Die Analyse defekter Baugruppen ist ein wesentlicher Bestandteil der Qualitätssicherung der Firma Bühler Technologies.

Um eine aussagekräftige Analyse zu gewährleisten muss die Ware möglichst unverändert untersucht werden. Es dürfen keine Veränderungen oder weitere Beschädigungen auftreten, die Ursachen verdecken oder eine Analyse unmöglich machen.

Bei elektronischen Baugruppen kann es sich um elektrostatisch sensible Baugruppen handeln. Es ist darauf zu achten, diese Baugruppen ESD-gerecht zu behandeln. Nach Möglichkeit sollten die Baugruppen an einem ESD-gerechten Arbeitsplatz getauscht werden. Ist dies nicht möglich sollten ESD-gerechte Maßnahmen beim Austausch getroffen werden. Der Transport darf nur in ESD-gerechten Behältnissen durchgeführt werden. Die Verpackung der Baugruppen muss ESD-konform sein. Verwenden Sie nach Möglichkeit die Verpackung des Ersatzteils oder wählen Sie selber eine ESD-gerechte Verpackung.

Beachten Sie beim Einbau des Ersatzteils die gleichen Vorgaben wie oben beschrieben. Achten Sie auf die ordnungsgemäße Montage des Bauteils und aller Komponenten. Versetzen Sie vor der Inbetriebnahme die Verkabelung wieder in den ursprünglichen Zustand. Fragen Sie im Zweifel beim Hersteller nach weiteren Informationen.

Analysing defective assemblies is an essential part of quality assurance at Bühler Technologies.

To ensure conclusive analysis the goods must be inspected unaltered, if possible. Modifications or other damages which may hide the cause or render it impossible to analyse are prohibited.

Electronic assemblies may be sensitive to static electricity. Be sure to handle these assemblies in an ESD-safe manner. Where possible, the assemblies should be replaced in an ESD-safe location. If unable to do so, take ESD-safe precautions when replacing these. Must be transported in ESD-safe containers. The packaging of the assemblies must be ESD-safe. If possible, use the packaging of the spare part or use ESD-safe packaging.

Observe the above specifications when installing the spare part. Ensure the part and all components are properly installed. Return the cables to the original state before putting into service. When in doubt, contact the manufacturer for additional information.



1800-OILSOL
1800-645765

<https://oilsolutions.com.au/>

sales@oilsolutions.com.au

