

pumps with built-in unloading valves

for P50™/P51™ tandem pumps

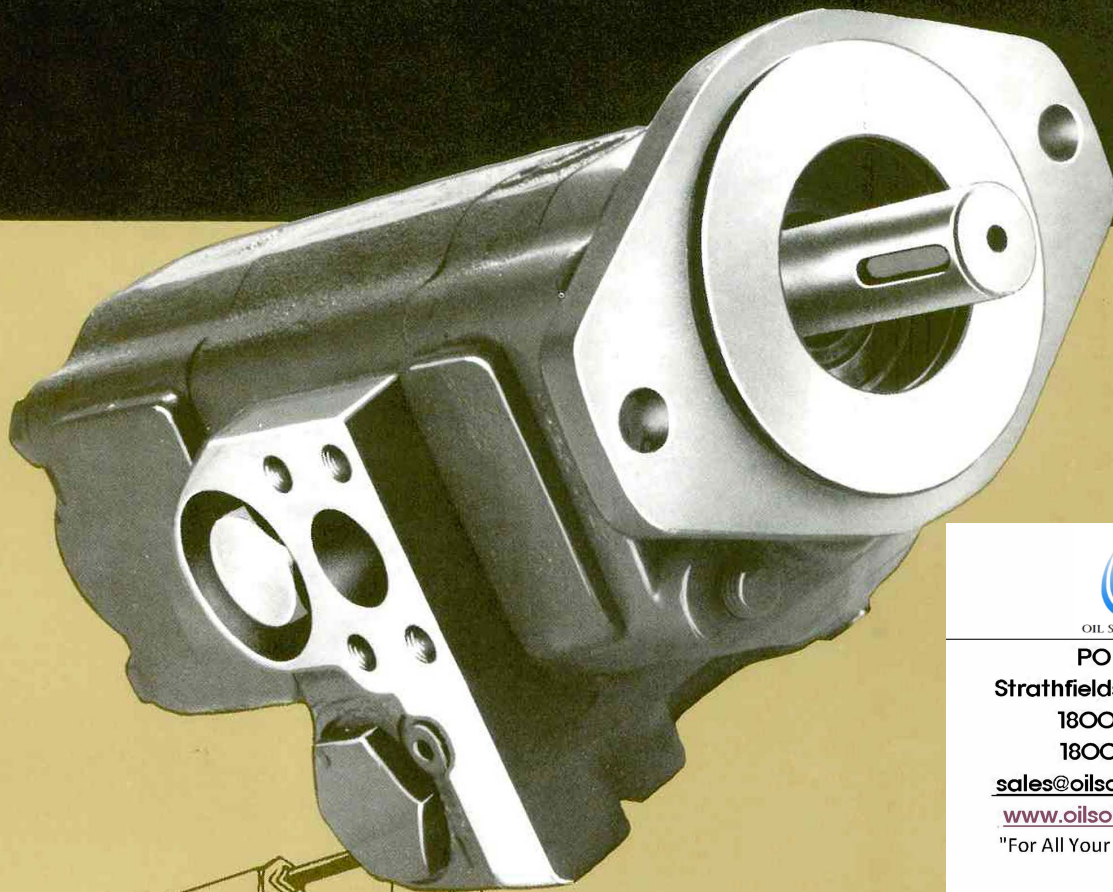

OIL SOLUTIONS

PO Box 38
Strathfieldsaye, VIC, 3551
1800 OIL SOL
1800 645 765

sales@oilsolutions.com.au

www.oilsolutions.com.au

"For All Your Hydraulic Needs"

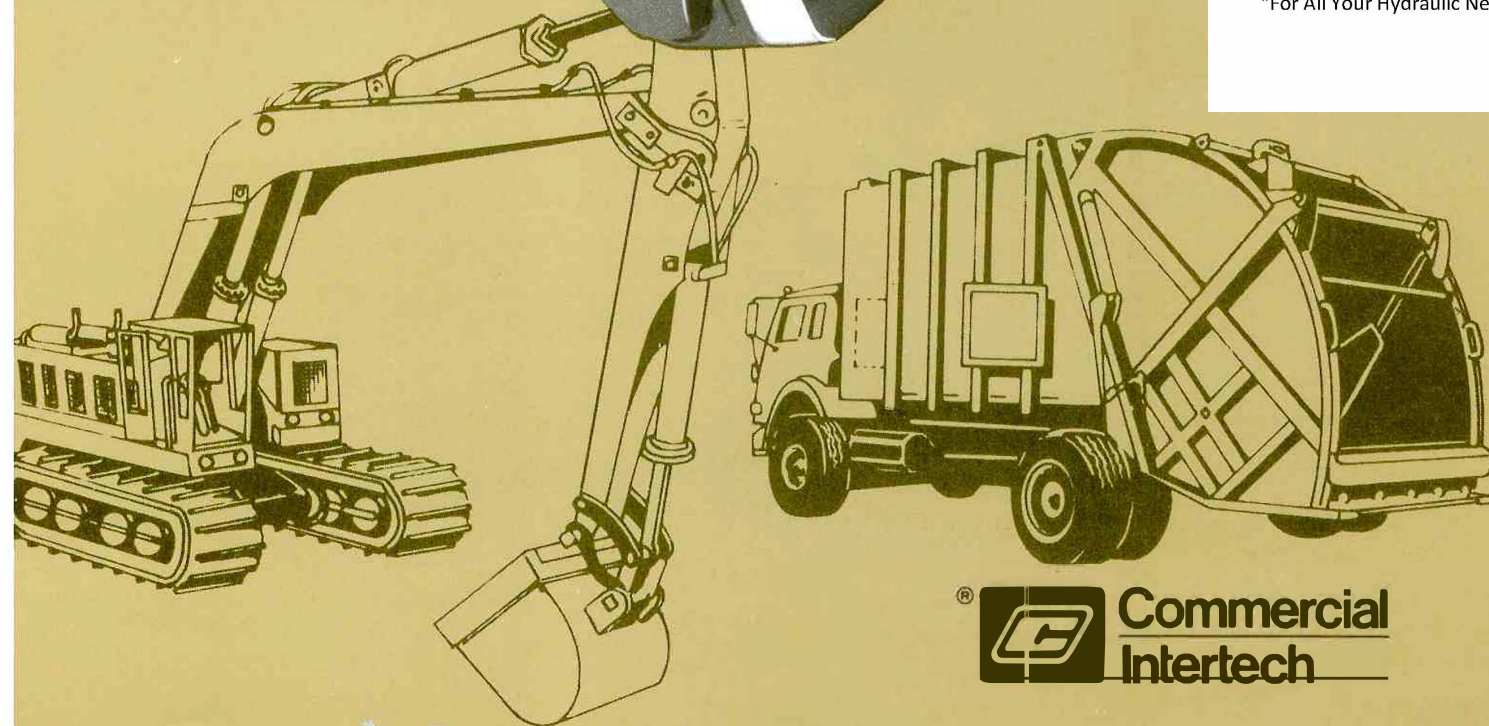

®



**Commercial
Intertech**

compact unloader pumps

pumps with built-in unloaders

Commercial's P50/P51 pumps with built-in unloader valves combine the high speed advantages of tandem pump flow with the lower horsepower requirement of a single pump.

Unloader valves from Commercial offer great flexibility of design and economy of operation for today's unloader circuits. They can be built into the bearing carriers of P50 and P51 gear pumps. Unloader valves allow engines used to drive a machine's hydraulic system to be downsized while maintaining, or even

improving, work cycle efficiency. When motive power is the engine's main function, an unloader valve makes maximum use of available horsepower to supply component speed or break-out force.

We offer six unloader valve configurations to suit a variety of applications. These are: air to load, air to unload, flow

sensing, pressure sensing, flow and pressure sensing, and pressure sensing with horsepower summation.

P50/P51 pumps with built-in unloaders operate at pressures to 3000 psi and offer displacements up to 65 gpm per gear section. When the application requires greater flow, D-Line valve banks can handle outputs to 145 gpm at pressures to 3500 psi.



dimensional data (inches)

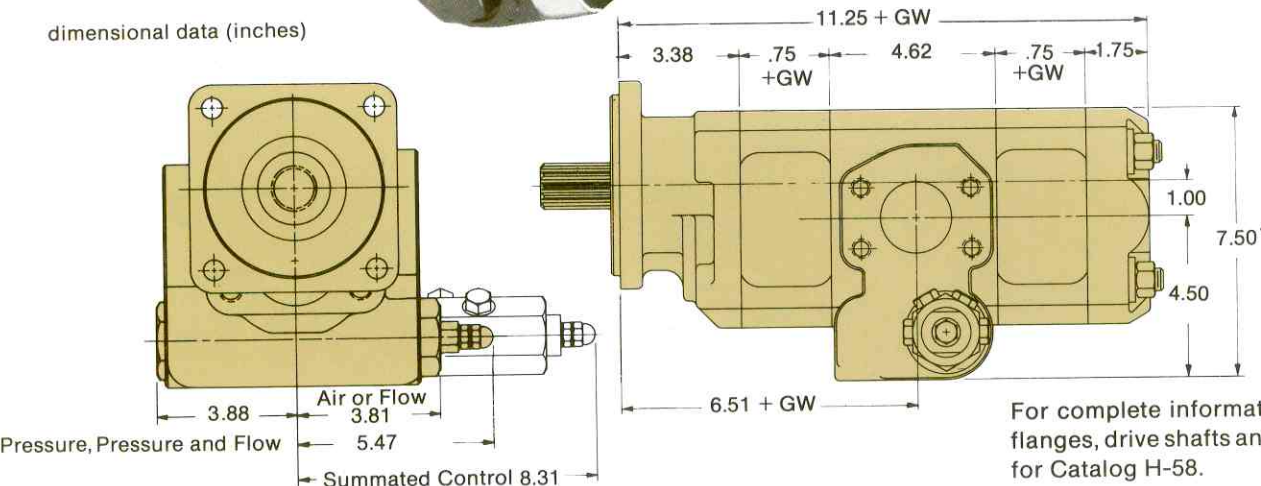

For complete information on mounting flanges, drive shafts and dimensions ask for Catalog H-58.

unloader circuit options

air-actuated unloader pumps

Either of these two units may be used in manual or automatic circuits to load or unload one section of the pump. In either case, air to shift the valve is generally taken from a receiver tank in the braking system. A spring returns the unloader valve to its original position. Air-actuated models are available only as built-in components of the P50/P51 pumps.

Air to load

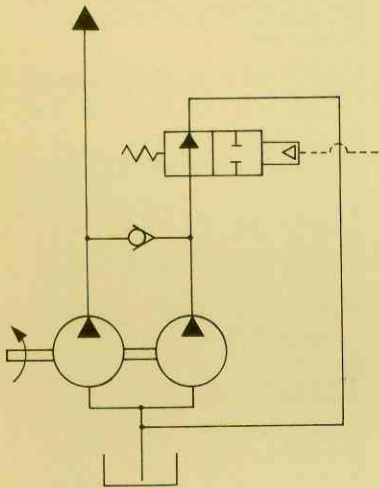

Air to unload

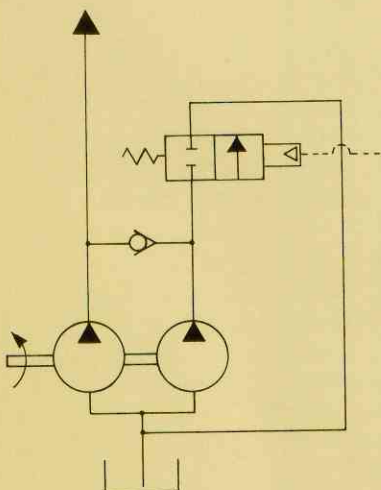

pressure-sensitive unloader pumps

The unloading spool is held in the high-flow position by a spring. At a predetermined setting, a relief valve opens thereby allowing hydraulic pressure to shift the spool to the low-flow position. This is the most commonly used unloader circuit. Generally, those applications requiring cylinders to fill quickly and then operate at higher pressure near the end of their stroke use this circuit.

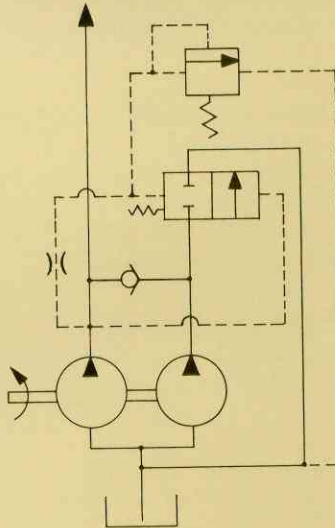

flow-sensitive unloader pumps

A fixed orifice in the valve is matched to the flow requirements of the machine at a given engine speed. Spring loading holds the spool in the high-flow position. If the operator increases engine speed, therefore increasing pump flow beyond the predetermined optimum, a hydraulic imbalance is created which shifts the spool and unloads one pump section. In addition to fuel savings and noise reduction, this design can reduce initial costs by allowing downstream lines and control valves to be downsized to match the continuously running pump section. Because the unloading signal is taken from this same section, the amount of heat generated and horsepower required are significantly reduced.

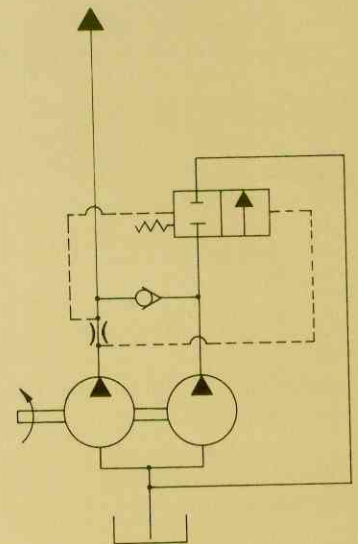

pressure- and flow-sensing unloader pumps

These units combine the features of pressure- and flow-sensing unloaders. They react to whichever occurs first, increased flow or increased pressure, and unload one section of the pump at a predetermined flow or pressure setting. This combination permits high-pressure work to be done at running or idling engine speeds without unnecessary flow which wastes horsepower.

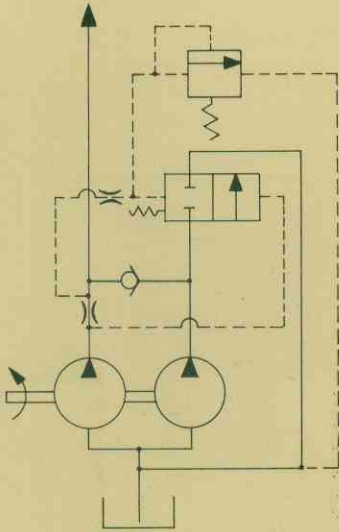

pressure-sensitive unloader pumps with horsepower summation

When two tandem pumps with unloaders are used on the same engine, the sensing valves are cross-connected. Both valves are pressure-sensitive versions with an additional port in their relief valve housings to receive a pilot signal from their opposite unloading pump. Such cross-sensing makes high-pressure operation of one circuit possible while maintaining the capability of maximum speed in the other. Moreover, relief valve settings of unloader valves can be set so that a predetermined pressure in each circuit will unload one section in either or both pumps. This reduces the pump's horsepower demand and often allows a smaller, more economical engine to be used. Horsepower-summation circuits are commonly used on excavators where fast-boom, fast-hoist and high-pressure digging functions are required.

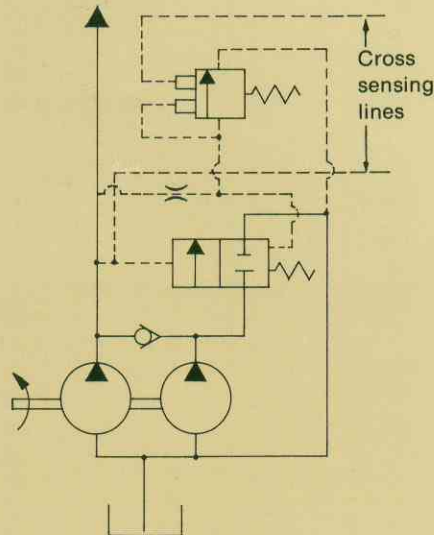

also available in valve bank unloader inlets

Horsepower summing circuits can be constructed by cross-connecting two tandem pumps to separate valve banks, each having unloader inlets. This circuit allows flow from one section of either or both pumps to be unloaded at a pre-selected pressure. Horsepower-summation unloader inlets can be used with 100 gpm and 145 gpm D-Line sections which are rated for 3500 psi in parallel or series circuits.

With the exception of the air-actuated and flow-sensitive versions, Commercial's unloader valves can be built into inlets of the 65 gpm, 85 gpm and 125 gpm D-Line valves for operation at pressures to 2500 psi. These inlets unload flow from one section of a tandem pump at predetermined system pressures.

dimensional data (inches)

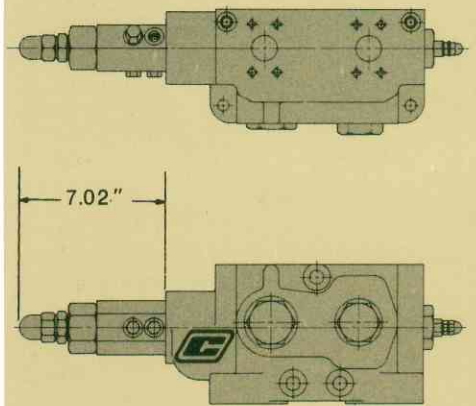

NOTE: In accordance with our policy of continuing product development, we reserve the right to change specifications shown in this catalog without notice.

horsepower efficiency

P50/P51 unloader performance characteristics

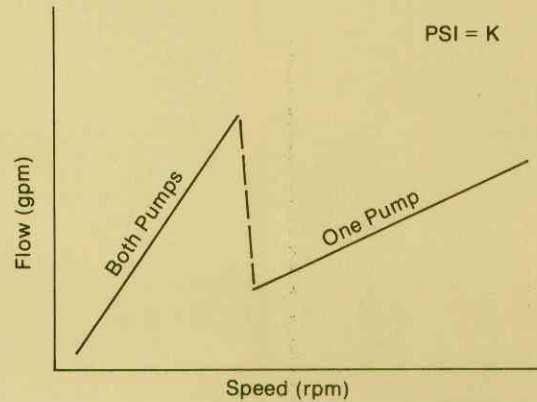
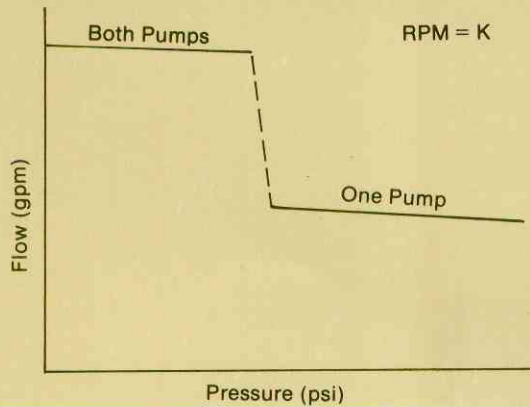

P50/P51 performance data

AVERAGE OUTPUT — U.S. Gallons

P50 @ 2000 psi/P51 @ 2500 psi

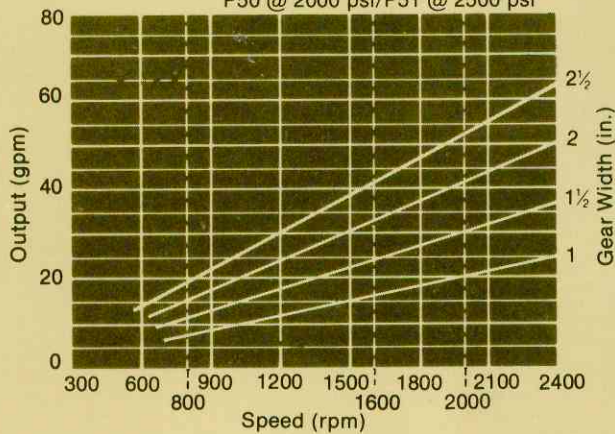

AVERAGE INPUT — (hp) @ 2500 psi

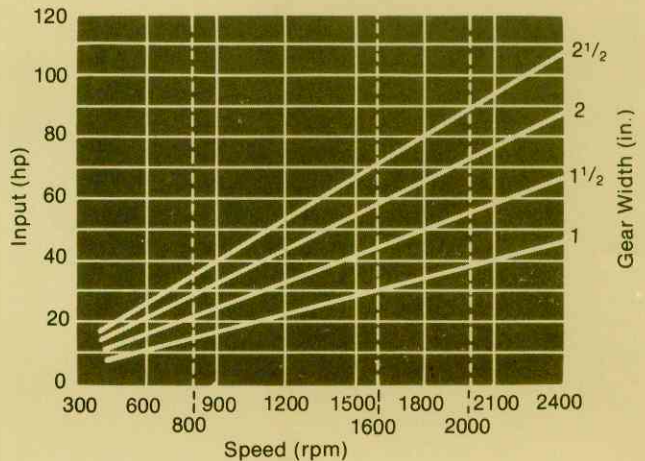

Average output flow • U.S. Gallons per Minute
• British Imperial Gallons per Minute
• Litres per Minute

Speed rpm	Gear Width (inches)						
	1	1 ¹ / ₄	1 ¹ / ₂	1 ³ / ₄	2	2 ¹ / ₄	2 ¹ / ₂
	8.5	10.5	13	15	17.5	20	22
900	7	8.5	11	12.5	14.5	16.5	18.5
	32	40	49	57	66	76	83
1200	12	15	18	21	24	27	30
	10	12.5	15	17.5	20	22.5	25
	45	57	68	79	91	102	114
1500	15	19	23	27	31	35	39
	12.5	16	19	22.5	26	29	32.5
	57	72	87	102	117	132	148
1800	18	23	27.5	32.5	37.5	42	47
	15	19	23	27	31	35	39
	68	87	104	123	142	159	178
2100	21.5	27	32.5	38.5	44	49.5	55
	18	22.5	27	32	36.5	41	46
	81	102	123	146	167	187	208
2400	25	31	37	44	51	57	63.5
	21	26	31	36.5	42.5	47.5	53
	95	117	140	167	193	216	240