

VT-HACD-DPC

Digital control card for hydraulic clamp units

RE 30147-B/08.07
Replaces: 11.06

Installation and Operation

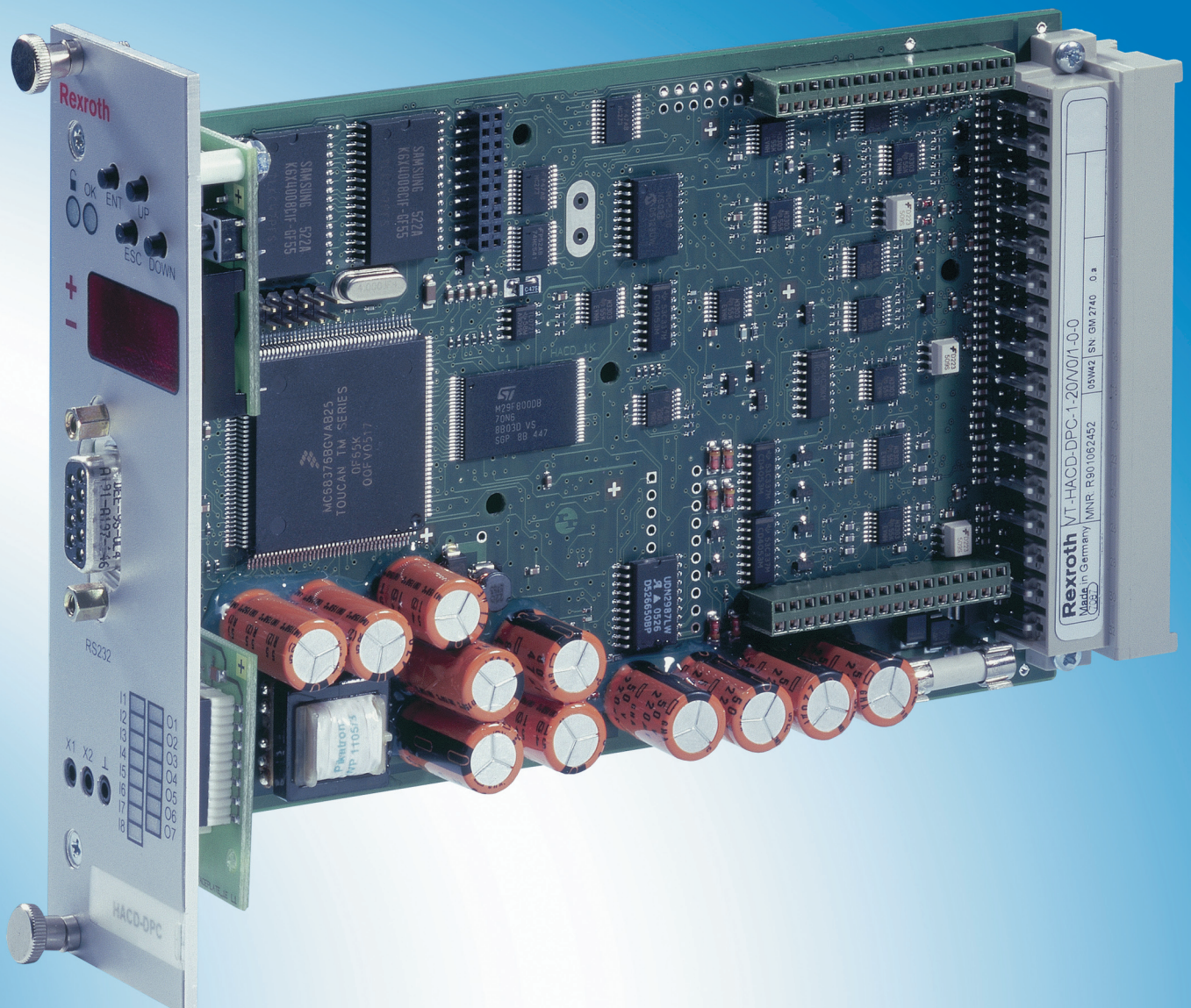

Contents

1	GENERAL.....	4
1.1	ABOUT THIS MANUAL.....	4
	<i>Additional Documentation</i>	5
	<i>Characters and Symbols</i>	5
1.2	SCOPE OF SUPPLY.....	6
1.3	REQUIREMENTS.....	6
2	INSTALLING THE HACD-DPC.....	8
2.1	SAFETY REQUIREMENTS.....	8
	<i>Proper Use</i>	9
	<i>Personnel Selection and Qualification</i>	9
	<i>Design Changes and Electrical Installation</i>	10
2.2	REPAIR AND TROUBLESHOOTING.....	11
2.3	TRANSPORT, STORAGE AND HANDLING THE CONTROLLER CARD.....	12
2.4	CARD INSTALLATION.....	13
2.5	EDGE CONNECTOR TERMINALS AND PIN ASSIGNMENTS ON THE.....	14
3	STARTUP OF THE HACD-DPC CONTROLLER CARD.....	18
3.1	PREPARING FOR USE.....	18
3.2	INSTALLING BODAC SOFTWARE.....	19
	<i>Installation Requirements</i>	19
	<i>BODAC Setup</i>	19
3.3	INITIAL STARTUP WITH BODAC.....	20
4	HACD-DPC OPERATION.....	22
4.1	DISPLAY/INPUT KEYS AND CONNECTORS ON THE FRONT PANEL.....	22
4.2	DIAGNOSTICS TEST JACKS.....	23
4.3	MENU TREE FOR SETUP AND PARAMETERS.....	23
4.4	DISPLAY/INPUT KEY OPERATIONS.....	27
5	DIAGNOSTICS.....	32
5.1	DIAGNOSTIC OPTIONS ON THE HACD-DPC CONTROLLER CARD.....	32
5.2	DIAGNOSTICS USING BODAC.....	32
6	DETECTING ERRORS.....	34
6.1	ERROR MESSAGES.....	34
6.2	CHANGING FUSES.....	34
7	INDEX.....	39

1 General

1.1 About this Manual

Before installing or operating your HACD-DPC Controller card for the first time, you should read this Manual. Please note the safety requirements described in section 2.1

Persons involved with the start-up and operation of the controller card should have proper training on the installation and operation of this type of equipment.

This manual is intended to inform you about the functions of this controller card and its intended use.

The Manual contains important safety instructions on proper installation and operation of the controller card. Observing these instructions will help you:

- avoid hazards and dangers
- minimize repair costs and downtime
- increase the useful life and reliability of the controller card.

Additionally, please observe all regulations that are in effect in the country and/or community to prevent accidents and to protect the environment.

This manual only describes the installation and operation of the controller card. Information about starting up the controller card using BODAC software is located in a separate document: "Operation of the BODAC Software and Starting up the HACD-DPC Control Card". A list of documentation for the HACD-DPC can be found in the "Additional Documentation" section.

Version: 1.1

Additional Documentation

Included with this manual is the document "HACD-DPC Digital Controller for Hydraulic Clamp Units".

It contains:

- RE sheet "RE 30 147" in paper form.
- Document RE 30 147-B: "Installation and Operation" (included with the shipment).
- Document RE 30 147-01-B "Start-up and Operation" as online help (part of the BODAC package)
- Document RE 30 146-02-Z "Start-up CANopen Interface" as online help for description of the CANopen interface (part of the BODAC package)
- Internet: www.boschrexroth.com/hacd

Characters and Symbols

The following characters and symbols are used in the manual:

- ▶ Action symbol: The text following this symbol describes actions. These should be performed, from top to bottom, in the given order.
- ✓ Result symbol: The text following this symbol describes the results of an action.



Following this symbol you will find notes and useful tips for optimal use of the controller card.

Warning symbols

Special safety notes are provided at the relevant locations. These are indicated by the following symbols.



General hazard potential

Indicates a potentially hazardous condition which, if not avoided, could result in death or serious injury.

If the hazard source can be specifically indicated, the corresponding pictogram will be used.



Electrical current hazard

This symbol refers to a hazardous condition caused by electrical current which, if not avoided, could result in death or serious injury.



Equipment damage

This symbol pertains to actions which could result in damage to equipment.

1.2 Scope of Supply

The equipment is packed in anti-static packaging to protect the controller card from electrostatic discharge. Observe instructions on the top side of the packaging.

Included in the shipment:

- HACD-DPC Controller Card
- RE sheet RE 30 147-B

1.3 Requirements

Mounting the controller card in a 19" rack:

- VT 19 101
- VT 19 102
- VT 19 103
- VT 19 110.

described in datasheet RE 29 768, or mounted in a card holder

- VT 3002-2x/G64

described in datasheet RE 29 928.

The card holder should be used only inside a control cabinet, as there is no protection from accidental contact.

If no power is provided by the user, the following power supply is available as an option:

- VT-NE30

described in datasheet RE 29 929.

Notes

2 Installing the HACD-DPC

2.1 Safety Requirements

Operate the HACD-DPC controller card only if it is not damaged and is in proper operating condition and is applied for its intended purpose. Observe all safety and hazard instructions in the included documentation.

When faults occur, which compromise safety and result in changes in operating conditions, shut down the controller card immediately and notify responsible personnel.

Fault free and safe running of the controller card assumes appropriate transport, storage and installation, as well as proper startup and operation.

The HACD-DPC Control Card has been built using the latest technology, and in accordance with recognized safety standards. Nevertheless, operation may result in hazard to persons or property if:

- The HACD-DPC Controller Card is not used properly. (see page 9, Proper Use)
- The HACD-DPC Control Card is not installed, commissioned and operated by qualified persons.
- Changes or modifications are made to the HACD-DPC controller card.
- Safety requirements and safety notes are not observed.

The HACD-DPC controller card is intended for industrial use.

The card must not be operated until it has been determined that the system in which the controller card is installed, meets all applicable standards and safety regulations for the application.

In European countries: EC Directive 89/392/EWG (Machine Directive)

Operation is permitted only when applicable EMC regulations for the application are met.

Adherence to limits defined by regulations and standards are the responsibility of the manufacturer of the system or machine.

In European countries: EC Directive 89/336/EWG (EMC Directive)

In the United States: National Electrical Code (NEC) and National Electrical Manufacturers Association (NEMA), as well as local standards should be observed. The operator is required to adhere to the above named standards at all times.

Proper Use

The HACD-DPC controller card is designed for controlling electrohydraulic clamp units.

Applications include:

- open loop Jog Mode
- closed loop position and pressure control for
 - Open Mold with decompression
 - Close Mold with mold protection
 - Close Stop 2 step final close (optional)
 - Tonnage

Proper use requires adherence to the manuals and supplementary documentation, and observing relevant safety and operating standards.

Personnel Selection and Qualification

Operation and Startup

Operation and startup of the HACD-DPC controller card requires specialized skills. Therefore this work should be performed only by properly trained individuals.

Only persons who are trained or properly instructed should start up and operate the HACD-DPC controller card. Additionally the oversight of a qualified supervisor may be advised.

Personnel are considered qualified if they are familiar with the installation, startup and operation of the HACD-DPC controller card, and with all the warning notes and safety regulations contained in the accompanying documentation.

Work on the electrical equipment must be performed only by qualified specialists or by personnel appropriately instructed and under the supervision and guidance of persons qualified and familiar with electrical safety standards.

An electrical specialist is someone who, based on his technical knowledge and training, as well as knowledge of the relevant standards, is able to evaluate the tasks assigned to him, recognize potential hazards and take the appropriate safety measures.

Repair and troubleshooting

Repair and troubleshooting requires specialized skills. Therefore, this work should be performed only by trained and designated specialists.

Design Changes and Electrical Installation

User changes to the HACD-DPC controller card may result in safety hazards.

Note the following recommendations on electrical installation:

- Use low-capacitance cables. Make cable connections without intermediate connections whenever possible.
- Control electronics should be isolated from electromagnetic noise sources (IE: V/F drives).
- Power wiring should not be routed in the vicinity of control electronics.
- Power wiring should not be routed in the vicinity of control wiring or cables.
- Route sensor lines separately.
- Maintain a distance of at least 1 meter from antenna lines, RF devices and radio equipment.
- When using differential inputs switch both inputs on and off at the same time.
- When switching signal inputs, use dry circuit rated relays with gold-plated contacts (low voltages, low currents)
- Always shield all analog signal lines. Connect shields at the card end only, connecting to the "Shield" terminal, and leave the other end open to prevent ground loops.
- Connect to an appropriate system ground using stranded copper wire (min 2.5mm² / 12 AWG)
The system ground is an essential component of the EMC protection for the controller card. The ground provides a path for noise that could otherwise enter the controller card through the signal and power supply lines. Noise is bypassed only if the system ground does not couple noise into the controller card. Rexroth also recommends shielding solenoid wiring.
- Do not use logical signals from the controller card (IE: "OK" signal) for switching machine safety circuits (see European Norm "Safety Requirements for Fluid Power Systems and Components" EN982:1996).
- If bus system is used, please note the requirements of the bus specifications:
CANopen: CiA-301, CiA-302

2.2 Repair and Troubleshooting

If the control cabinet contains additional electrical components utilizing high voltage, always observe safety standards to prevent accidents ! Use appropriate protective gear, such as safety shoes and safety gloves, when prudent !

Use appropriate tools (IE: insulated tools)

Before opening control cabinet doors, open the main disconnect.

To ensure safe working conditions, observe the following safety rules:

- Remove all power
- Ensure against unintended energization: lockout devices when possible, and use lockout warning tags
- Verify that voltage is not present
- Cover or close off adjacent areas that are still energized.

If work on energized components is necessary, have a second person present as a safety backup to actuate an E-STOP switch or open the main disconnect, if necessary. Use insulated tools only.

2.3 Transport, Storage and Handling the Controller Card

The packaging contains notes on handling of the controller card. These must be strictly followed.

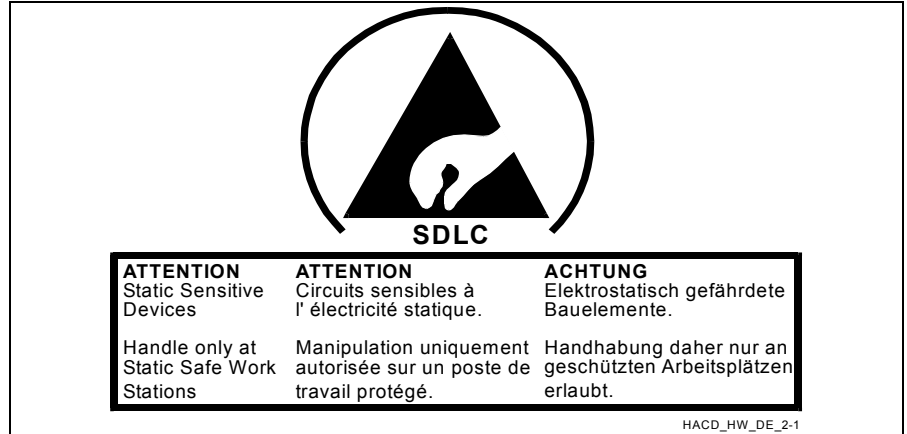

Fig. 1 Notes for handling printed on the packaging

Observe the following:

- Keep the controller card away from moisture and dust
- Observe the allowable storage temperature range of -20°C to $+80^{\circ}\text{C}$.
(allowable operating temperature: $0 - 50^{\circ}\text{C}$)



NOTE!

Electrostatic discharge (ESD) can damage components on the controller card. To prevent damage, observe the following recommendations.

Discharge static voltage from your body using accepted practices.

Work in a safe environment. Do not use any devices in the working environment that generate or hold static charge. Avoid working with the controller card in areas where floors or work surfaces is composed of materials that can generate a static charge.

Handle the controller card carefully. Do not touch any exposed pins or electronic components.

Transport and store the control card in its original packaging.

2.4 Card Installation

Remove the card from its packaging only at a protected work place.
Do not touch any electrical components when placing the controller card in its proper card holder as shown in Fig. 2..

Correctly installing the HACD-DPC controller card:

- ▶ Remove power from the rack when installing the card.
- ▶ Hold the card by the front panel and remove it from the packaging.
- ▶ Slide the card into the guide rails of the rack without using excessive force, as shown in Fig. 2 “Installing the control card”.
- ▶ Snap the edge connector in place by gently pressing on the front panel.

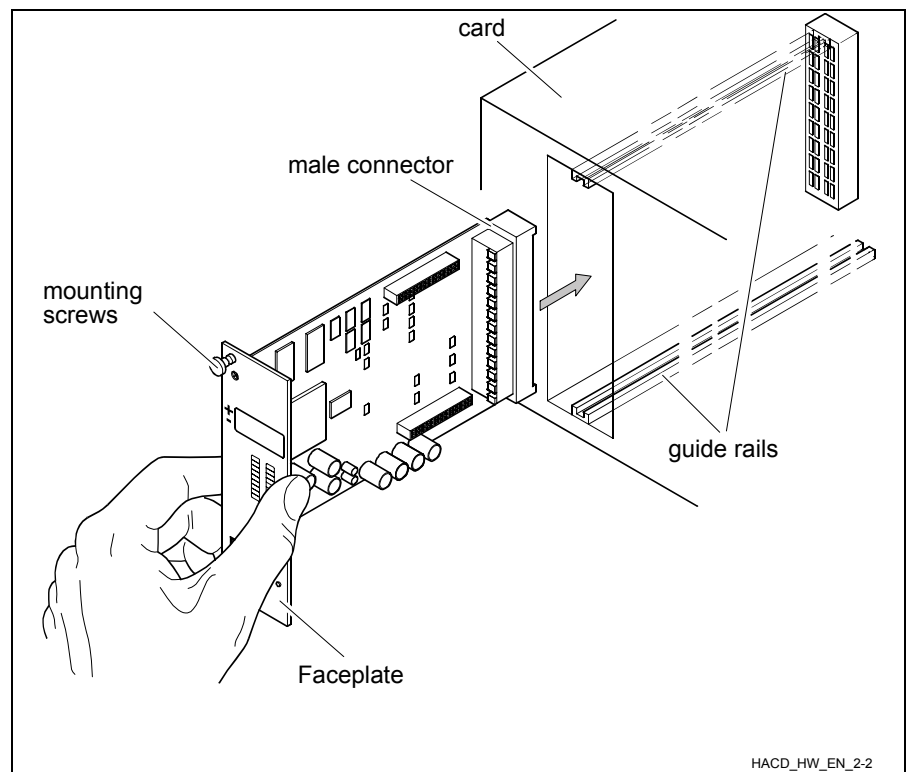

Fig. 2 Installing the controller card

- ▶ Tighten the two mounting screws on the front panel.
- ✓ The card is now installed correctly.

2.5 Edge Connector Terminals and Pin Assignments on the

The edge connector is a 64-pin, Type G (DIN 41612).

The pin assignments for the edge connector are not downward compatible with older amplifier products.

Pin assignment tables:

Row d	Pin	Description	Type	Specification
	2	DI 1 Soft Stop	Discrete input	log 0 = 0..2V, log 1 = 16..U _b
	4	DI 2 AUTO	Discrete input	log 0 = 0..2V, log 1 = 16..U _b
	6	DI 3 Close Permit	Discrete input	log 0 = 0..2V, log 1 = 16..U _b
	8	DI 4 Close/Jog Close	Discrete input	log 0 = 0..2V, log 1 = 16..U _b
	10	DI 5 Incremental Home	Discrete input	log 0 = 0..2V, log 1 = 16..U _b
	12	DI 6 Open/Jog Open	Discrete input	log 0 = 0..2V, log 1 = 16..U _b
	14	DI 7 Low Hold	Discrete input	log 0 = 0..2V, log 1 = 16..U _b
	16	DI 8 Final Close	Discrete input	log 0 = 0..2V, log 1 = 16..U _b
	18	Enable	Discrete input	log 0 = 0..2V, log 1 = 16..U _b (H active)
	20	DO 1 Mold Touch	Discrete output	U _b , 50mA, short-circuit protected
	22	OK ²⁾	Discrete output	U _b , 50mA, short-circuit protected
	24	nc ¹⁾		
	26	DO 2 Signal Fault	Discrete output	U _b , 50mA, short-circuit protected
	28	nc ¹⁾		
	30	Valve Output #1	Analog output	± 10V, R _{load} min = 1k 0-20mA, R _{load} max = 500R
	32	Valve Output #2 or pressure feedback or position feedback	Analog output	± 10V, 10mA R _{load} min = 1k

¹⁾ = Pin not used. Do not connect to this pins.

²⁾ = Signal indicates ready status of the controller card.

Row b

Pin	Description	Type	Specification
2	Spare	Analog input	
4	Spare	Analog input	
6	pressure feedback #1 +	Analog input	Differential input: $\pm 10V$ ($R_{in}>100k\Omega$),
8	pressure feedback #1-	Analog input	0...20mA with $R_{in} = 100\Omega$ ³⁾
10	Spare	Analog input	
12	Spare	Analog input	
14	pressure feedback #2+	Analog input	Differential input: $\pm 10V$ ($R_{in}>100k\Omega$),
16	pressure feedback #2 -	Analog input	0...20mA with $R_{in} = 100\Omega$ ³⁾
18	analog position feedback +	Analog input	Differential input: $\pm 10V$ ($R_{in}>100k\Omega$),
20	analog position feedback -	Analog input	0...20mA with $R_{in} = 100\Omega$ ³⁾
22	Spare	Analog input	
24	Spare	Analog input	
26	nc ¹⁾		
28	AGND	Analog GND	0V, reference for analog outputs
30	REF-	Reference voltage - 10V	- 10V, short-circuit protected, 30mA,
32	REF+	Reference voltage + 10V	+ 10 V, short-circuit protected, 30mA,

¹⁾ = Pin not used. Do not connect to this pins.

³⁾ = Because of the input circuitry the voltage drop over the high wattage resistor is dependant on the input current. This voltage drop has a linear character with a value of 1.7V at 4mA and 3.5V at 20mA.

Row z	Pin	Description	Type	Specification
	2	nc ¹⁾		
	4	nc ¹⁾		
	6	nc ¹⁾		
	8	nc ¹⁾		
	10	Shield	Shield	internally connected with z 20
	12	nc ¹⁾		
	14	nc ¹⁾		
	16	nc ¹⁾		
	18	nc ¹⁾		
	20	Ground	System ground	
	22	DO 3 At Open Position	Discrete output	U _b , 50mA, short-circuit protected
	24	DO 4 At Close Position	Discrete output	U _b , 50mA, short-circuit protected
	26	DO 5 At Close Pressure	Discrete output	U _b , 50mA, short-circuit protected
	28	DO 6 At Decomp. Pressure	Discrete output	U _b , 50mA, short-circuit protected
	30	U _B	Supply voltage	U _B + 24V DC U _B (t) _{max} + 35V DC U _B (t) _{min} + 21V DC
	32	LO	Supply GND	0V

¹⁾ = Pin not used. Do noconnect to this pins.

Row f	Pin	Description	Type	Specification
	2	DO 7	Discrete output	U _b , 50mA, short-circuit protected
	4	Clk +	Clock output SSI encoder	5V Signal RS-485 compatible
	6	Clk -	Clock output SSI encoder	5V Signal RS-485 compatible
	8	Data + UA1	Data input SSI encoder Incremental encoder input	5-24V Signal
	10	Data - /UA1	Data input SSI encoder Incremental encoder input	5-24V Signal
	12	UA2	Incremental encoder input	5-24V Signal
	14	/UA2	Incremental encoder input	5-24V Signal
	16	UA0	Incremental encoder input	5-24V Signal
	18	/UA0	Incremental encoder input	5-24V Signal
	20	nc ¹⁾		
	22	nc ¹⁾		
	24	nc ¹⁾		
	26	nc ¹⁾		
	28	CAN Gnd	CAN Bus reference	CAN specification
	30	CANL	CAN Bus input / output	CAN specification
	32	CANH	CAN Bus input / output	CAN specification

¹⁾ =	Pin not used. Do connect to that pins.
-----------------	--

3 Startup of the HACD-DPC Controller Card

3.1 Preparing for Use

The startup procedure for the HACD-DPC controller card depends on a variety of factors that are determined by the individual application. For this reason, only the basic startup steps are described in this manual.

Preparing the controller card for use:

- ▶ Carefully check cabling.
- ▶ Apply power to the HACD-DPC controller card.

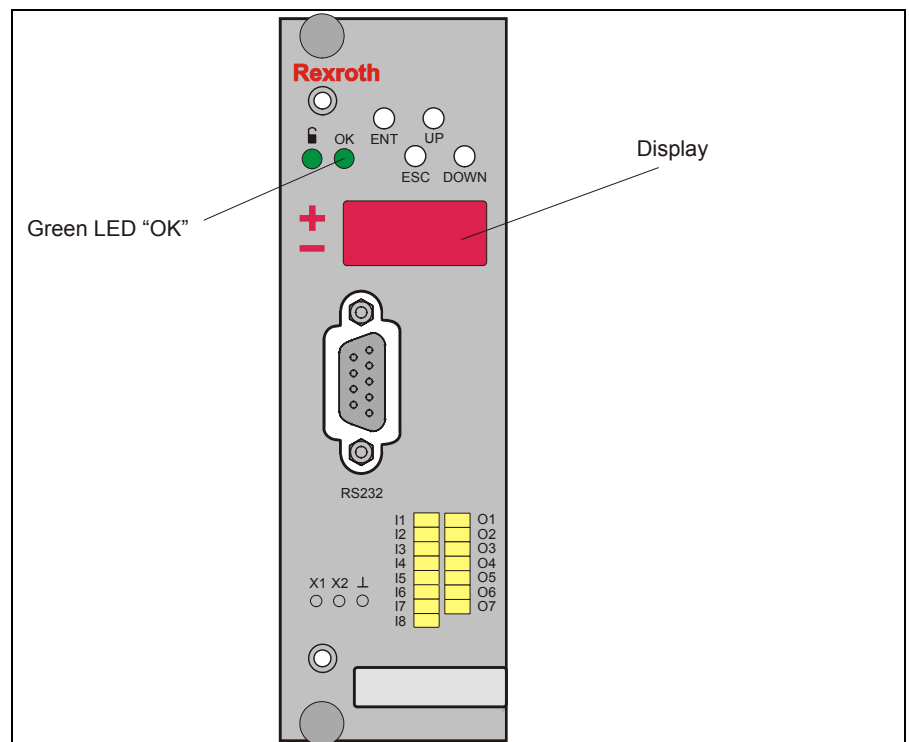

Fig. 3 Front panel of the HACD-DPC Controller Card

- ✓ The controller card performs an internal function test.
- ✓ The display on the controller card shows the manufacturer name and version number in scrolling text (when powered up)

3.2 Installing BODAC software

BODAC software ordering code SYS-HACD-BODAC-01/ (S/N R900777335) can be downloaded via Internet (www.boschrexoth.com/hacd). This software is used for initial startup and as a convenient configuration and monitoring tool for the controller card. BODAC can be used to configure the settings and parameters for optimal operation of the HACD-DPC controller card. The connected HACD-DPC card configures the function, menus and program windows in BODAC. This makes using the software easy.

Installation Requirements

- | | |
|-----------------|---|
| Hardware | <p>100% IBM compatible PC with the following minimum requirements:</p> <ul style="list-style-type: none">■ 200 MHz Pentium processor (or equivalent)■ 32 MB working memory (RAM)■ VGA graphics card, minimum resolution: 800x600 pixels■ Hard drive with minimum 2 MB available space■ CD-ROM drive■ Mouse■ Available serial port or specified USB/RS232 adapter (S/N R901066684) |
| Software | <ul style="list-style-type: none">■ Operating system: Windows™ NT / 2000 / XP. |

If the hardware/software requirements are met, you can install BODAC as described in the next section.

BODAC Setup

To start the installation of BODAC, execute the "Setup.exe" file.

Installing BODAC software:

- ▶ Insert the CD-ROM and locate the file “Setup.exe”.
- ▶ Double-click on “Setup.exe”.
- ✓ The setup program will load and display a start screen.
- ▶ To run Setup, follow the instructions on the screen.
- ✓ BODAC software will then be installed.

3.3 Initial startup with BODAC

After installing the HACD-DPC controller card in a rack, as described in section 2.4, "Installing the card", and all initial steps have been completed properly, the card startup is ready.

Before proceeding with the following steps, be sure that the following requirements have been met:

- Serial interface cable is available
- A serial port on the PC is available
- BODAC software is installed.

Proceed with the initial startup:

- Connect serial cable (S/N R900776897) to the connector on the HACD-DPC card.
- ▶ Plug serial cable into the serial port (COM) on the PC (or use USB converter – S/N R901066684).
- ✓ The HACD-DPC card and PC are now connected.
- ▶ Start the BODAC software.
- ▶ Perform the software-side startup as described in the “Starting up the HACD-DPC Control Card and Operation of the BODAC Software” document.

Notes

4 HACD-DPC Operation

4.1 Display/Input Keys and Connectors on the Front Panel

You can use the display, input keys and connectors on the front panel of the HACD-DPC to check parameters and settings, attach diagnostic instruments and connect the card to a PC.

The following illustration shows an overview of the display, input keys and connectors on the front panel.

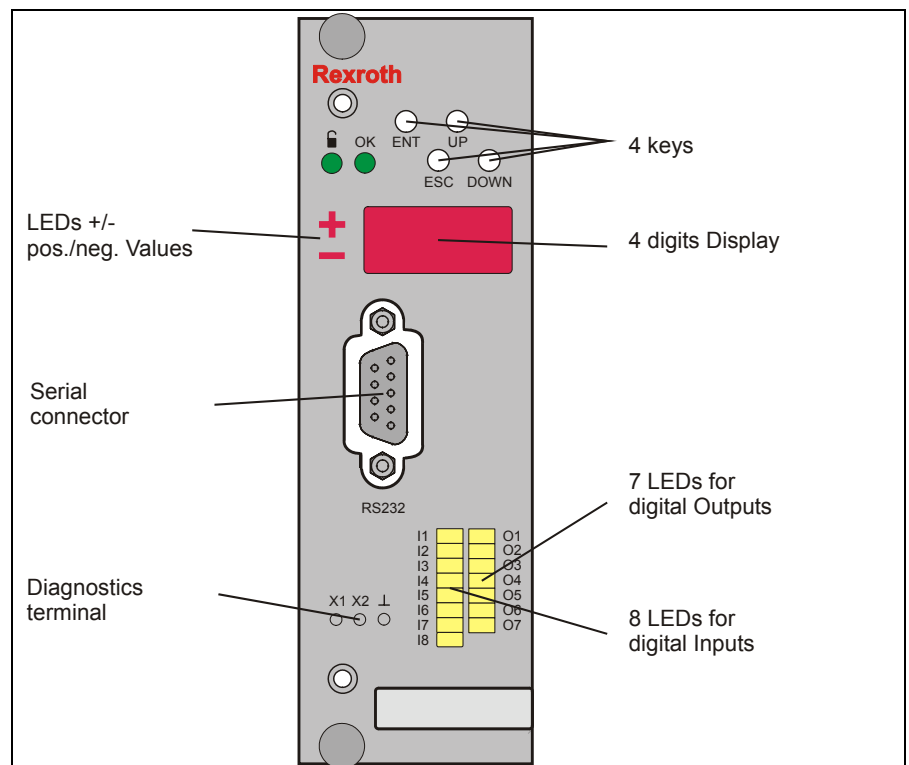

Fig. 4 Display, input keys and connectors on the control card

Display The display is four characters in length. Messages that exceed four characters are displayed as a scrolling display.

When parameters are displayed, the negative or positive sign is indicated by the “+” and “-” LEDs.

LEDs for Discrete I/O The input LEDs indicate the state of the discrete input signals. The output LEDs show the state of discrete outputs from the controller card. When a signal is present on a discrete I/O, the associated LED will illuminate.

Serial port The serial port on the front panel is configured as a standard RS-232 port using a 9-pin D-Sub female connector. A standard 9 pin serial data cable is used to connect the serial port to a PC.

Buttons

Four buttons are located on the front panel of the card. The functions of these buttons are described in detail in section 4.4 , "Performing operations".

4.2 Diagnostics Test Jacks

The diagnostic test jacks on the front panel of the card can be used to connect external test instruments. Two analog voltage signals are available to perform measurements.

4.3 Menu Tree for Setup and Parameters

The following contains an overview of the menus that can be selected using the buttons on the HACD-DPC controller card. Shown are the parameters and settings that are available.

An overview of the items listed below are shown on the following pages:

- Menu tree "Parameters"
- Menu tree "Parameters Part 2"
- Menu tree "Setup"

For a detailed description of the settings and parameters, please refer to document: "Starting up the HACD-DPC Control Card and Operation of BODAC Software".

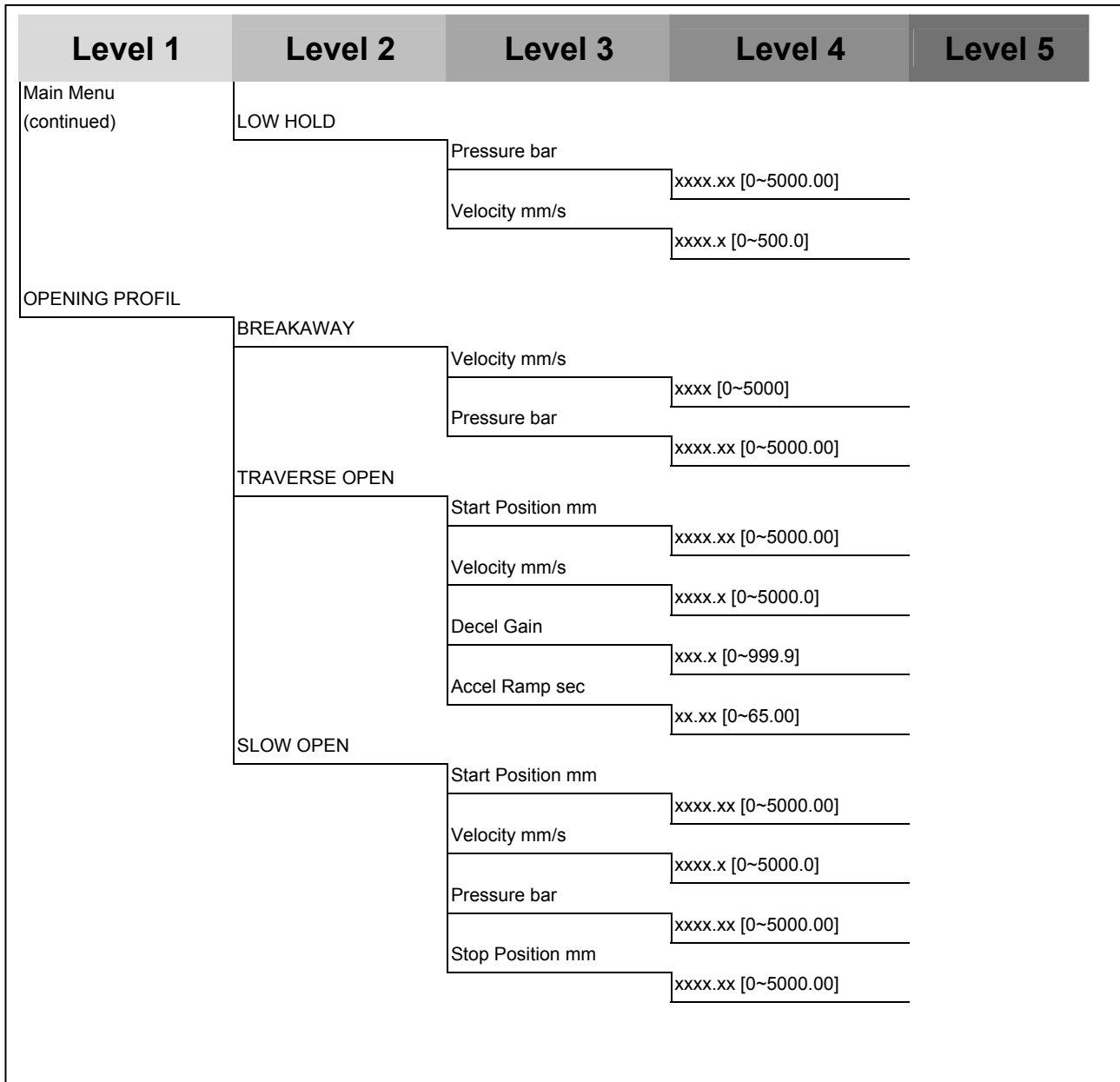

Fig. 6 Menu tree "Parameters Part 2"

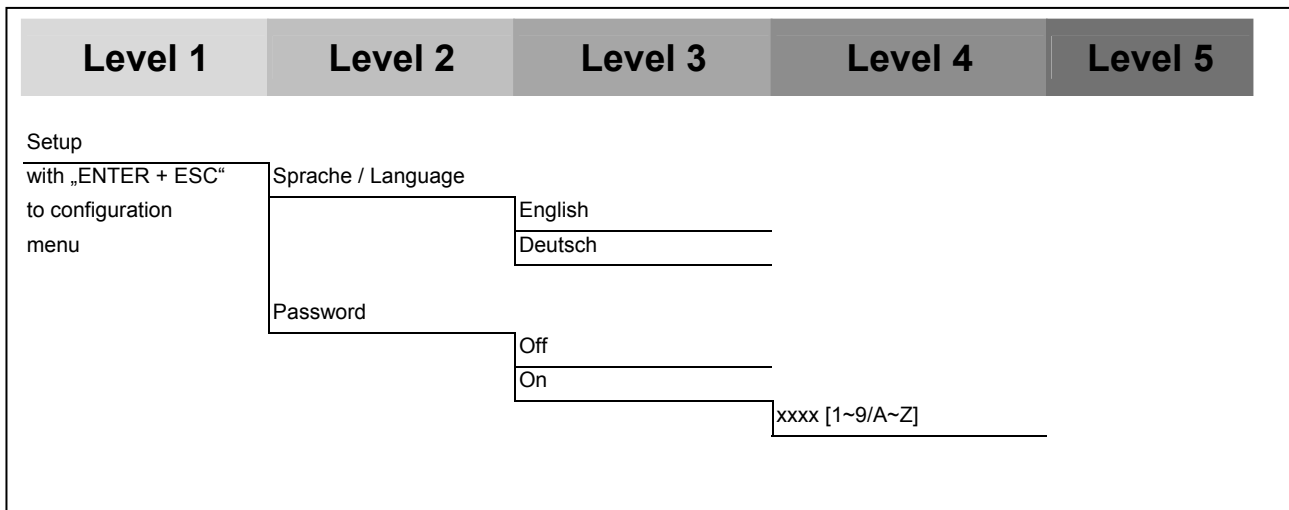

Fig. 7 Menu tree "Setup"

4.4 Display/Input Key Operations

All operations can be performed directly on the card using the "UP", "DOWN", "ENTER" and "ESCAPE" keys.



The keys are especially useful for quickly and easily checking, changing or correcting parameters and settings.

Always use BODAC software for the initial startup before placing the card in service.

Before making any changes to parameters or settings, familiarize yourself with the menu structure of the card. This can be found in section 4.3: "Menu tree for settings and parameters".

Key functions:

●
UP

Pressing the "UP" key moves in the upward direction, within the selected level, to available menu items. (for an overview, see section 4.3: "Menu tree for settings and parameters")

●
DOWN

Pressing the "DOWN" key moves in the downward direction, within the selected level, to available menu items (for an overview, see section 4.3: "Menu tree for settings and parameters").

●
ENTER

Change menu mode:

Press the "ENTER" key for 2 seconds or longer, to switch to configuration mode – "EDIT Parameters".

Change menu level:

Press the "ENTER" key to take you one level lower in the menu structure, or confirms an entered value.

Note: The entered value is stored immediately in memory!

●
ESCAPE

Pressing the "ESCAPE" key takes you one level higher in the menu structure.

● + ●
ENTER ESCAPE

Pressing the "ENTER" and "ESCAPE" keys simultaneously opens the configuration menu.

The configuration menu is structured in levels. The first level contains main categories, below which are additional sub-categories and settings. Depending on the entry selected, a main category may have up to 4 sub-levels.

The following figure illustrates the menu level structure.

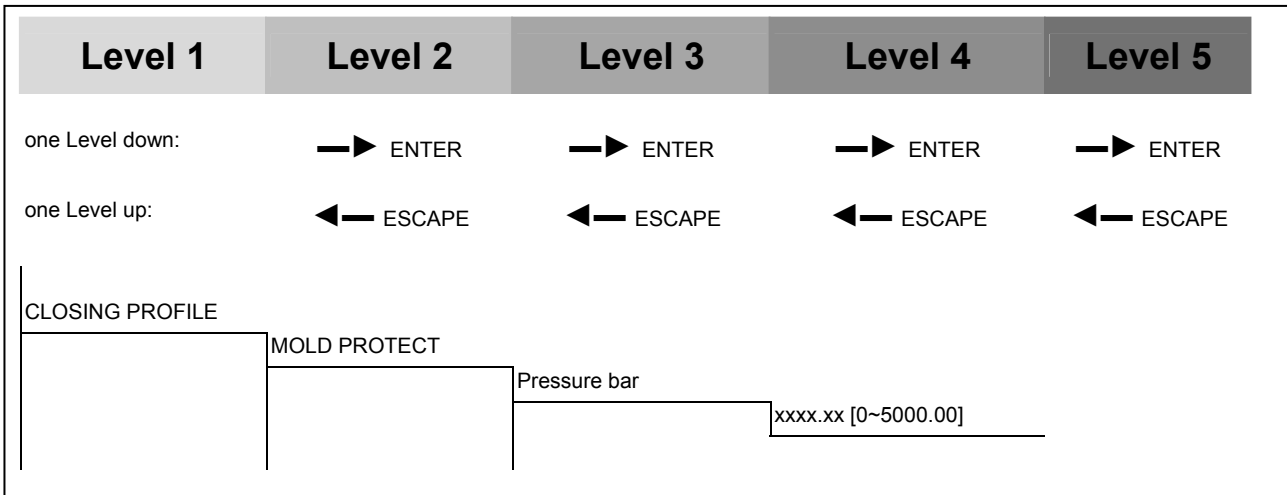

Fig. 8 Example of the menu levels in configuration mode

Changing from Run Mode to Configuration Mode – "EDIT Parameters":

The card must be in run mode.

The display will show scrolling text to display the manufacturer's name, the software version for the controller, or a custom configured text string.

- ▶ Press and hold "Enter" for at least 2 seconds until the display reads "EDIT Parameter".
- ✓ The controller card is now in "EDIT Parameter" mode.

Changing from Run Mode to Configuration Mode:

The card must be in run mode.

- ▶ The display will show scrolling text to display the manufacturer's name, the software version for the controller, or a custom configured text string.
- ▶ Press and hold "Enter" and "ESCAPE" simultaneously for at least 2 seconds (except when in "EDIT Parameter" mode, see above) until the display reads "Setup".
- ✓ The controller card is now in configuration mode.

To exit Configuration Mode:

As an example, the second level of the "Setup" menu is shown.

The display on the controller card shows the option "Sprache/Language".

- ▶ Press "ESCAPE".
- ✓ The display is scrolling "Setup".

- ▶ Press “ESCAPE”.
- ✓ The display will show scrolling text to display the manufacturer’s name, the software version for the controller, or a custom configured text string

✓



If while in Configuration Mode no entry is made within one minute, the controller card will automatically return to successively higher menu levels until Run Mode is reached.

The HACD-DPC Control Card is fully operational in Configuration Mode.

To change a parameter using the input keys:

As an example, the parameter "Pressure bar" (see illustration Menu Tree “Parameters – CLOSING PROFILE – MOLD PROTECT” is shown. In this case, set the parameter to: “10.00 bar”.

The card is now in Run Mode.

The display will show scrolling text to display the manufacturer’s name, the software version for the controller, or a custom configured text string.



WARNING!

When changing parameters using the input keys, hardware inputs are configured even when the discrete input “Enable” is active.

caution:

Do not change any analog input from voltage to current or current to voltage when active.

Changing the analog inputs configuration may result in incorrectly interpreted values.

This can result in uncontrolled system operation and damage to the machine!

- ▶ Press and hold the “ENTER” key simultaneously for at least 2 seconds until the display reads “CLOSING PROFILE”.
- ✓ The card is now in Configuration Mode.
 - ▶ Press the “UP” or “DOWN” keys to select “CLOSING PROFILE”.
 - ▶ Press “ENTER”.
- ✓ The card is now at the second level of the Configuration Menu.
 - ▶ Press the “UP” or “DOWN” keys to select “MOLD PROTECT”.

- ▶ Press "ENTER".
- ✓ The menu entry "Pressure bar" is shown.
- ▶ Press the "UP" or "DOWN" keys to select "Pressure bar".
- ▶ Press "ENTER".
- ✓ The current value is shown.
- ▶ Press "UP".

This creates a positive sign. Pressing „DOWN“ gives the value a negative sign.

- ▶ Press "UP" until "1" is displayed.
- ▶ Press "ENTER".
- ▶ Press "UP" until "0" is displayed.
- ▶ Press "ENTER".
- ▶ Press "UP" until "." is displayed.
- ▶ Press "ENTER".
- ▶ Press "UP" until "0" is displayed.
- ▶ Press "ENTER".
- ▶ Press "UP" until "0" is displayed.
- ▶ Press "ENTER".
- ✓ The parameter "Pressure bar " is now set to 10.00 bar and displayed.
- ▶ Exit the Configuration Menu by pressing "ENTER" five times.

Notes

5 Diagnostics

5.1 Diagnostic Options on the HACD-DPC Controller Card

Diagnostics terminal



The diagnostic test jacks on the front panel of the HACD-DPC controller card (see section 4.1 Display/Input Keys and Connectors on the , Fig. 4) provide two analog outputs with the following ratings:

- X1, not used
- X2, 10 Volts for test equipment having $R_i < 100 \text{ k}\Omega$
- COM, ground

Test Jack "X2"

Using the Testjack menu in BODAC, the signal to be measured can be selected.

Display indication when an error occurs

During initial startup, BODAC software can be used to select the action of the controller when an error occurs (available in the "Error" screen). If the controller card detects an error, which has been configured with BODAC software, the error will be displayed on the HACD-DPC controller card.



If the control card detects an error configured with BODAC software, respond as follows:

The display will flash "ERR" (Error) on the controller card!

Press "ENTER" to display the error message and clear the error.

The procedure for selecting the action desired when an error occurs can be found in the document "Starting up the HACD-DPC Control Card and Operation of the BODAC Software".

5.2 Diagnostics Using BODAC

The BODAC software includes additional detailed diagnostics capabilities.

The "Motion Data" screen and the "Status" screen display the current status of the controller card and of the connected sensors and devices.

Motion Data Screen The Motion Data screen displays the internal control signal values in the controller card. This provides a quick overview of the process status and values.

Status Screen The Status screen is used to display the status of the controller card. Each entry will display either "OK", "WARNING" or "ERROR" as a value.

For additional information on the Motion Data screen and the Status screen, refer to document " Starting up the HACD-DPC Control Card and Operation of the BODAC Software ".

6 Detecting Errors

6.1 Error Messages

Error message	Description
+/- 10V voltage	Reference voltage +10V (b32) or reference voltage -10V (b30) outside allowable tolerances.
24 V Power	Supply voltage Ub (z30) outside allowable tolerances 21...35V.
OK Short	Short circuit on discrete output OK.
DO1~DO7 short circuit	Short circuit on one or more of the 8 discrete outputs.
Checksum Flash	Checksum error in program or data memory (Flash or EEPROM)
Memory	Error in working memory (RAM)
Analog Input AI2 Press Fdbk #1	The signal on analog input AI1 is outside the valid signal range (adjustable in Analog Config screen in BODAC).
Analog Input AI4 Press Fdbk #2	The signal on analog input AI2 is outside the valid signal range (adjustable in Analog Config screen in BODAC).
Analog Input AI5 Analog Pos. Fdbk	The signal on analog input AI3 is outside the valid signal range (adjustable in Analog Config screen in BODAC).
Spare AI1, AI3, AI6	The signal on analog input AI1, AI3, AI6 is outside the valid signal range (adjustable in Analog Config screen in BODAC).
Block Timeout	The block time value for a block has timed out, without another block being called.
SSI	Cable fault on SSI encoder
Following Error	A control difference between setpoint (LC1) and feedback (LFB1). The difference value (window) and time delay (delay) can be set in the controller card
Max Freq. Fault	The max. frequency limit of the incremental encoder is exceeded.
Encoder Channel A	Fault in Incremental Encoder Channel A
Encoder Channel B	Fault in Incremental Encoder Channel B
Bus Fault	Profibus: The Slave has left condition "DATA_EXCHANGE" CANopen: The node has left the condition "OPERATIONAL" DeviceNet: The node has left the condition "ONLINE"

6.2 Changing fuses

The controller card is protected against overload by means of a fuse. The fuse is the following type:

- F / 4A / 250V

**NOTE!****The fuse is defective and must be replaced!**

The fuse has opened due to mechanical damage or a product defect.

In this case, replace the fuse with a new one of the type indicated above.

The fuse has opened due to external connections, IE: externally connected components or wiring connected to the controller card have faulted.

In such cases, diagnose and correct the problem that caused the fuse to open.

Only then replace the fuse with a new one.

Replacing the fuse on the HACD-DPC Control Card:

- ▶ Remove HACD-DPC controller card the card holder (reverse of the procedure described in section 2.4 Card Installation)
- ▶ Gently remove the fuse from the fuse holder (see Fig. 9).

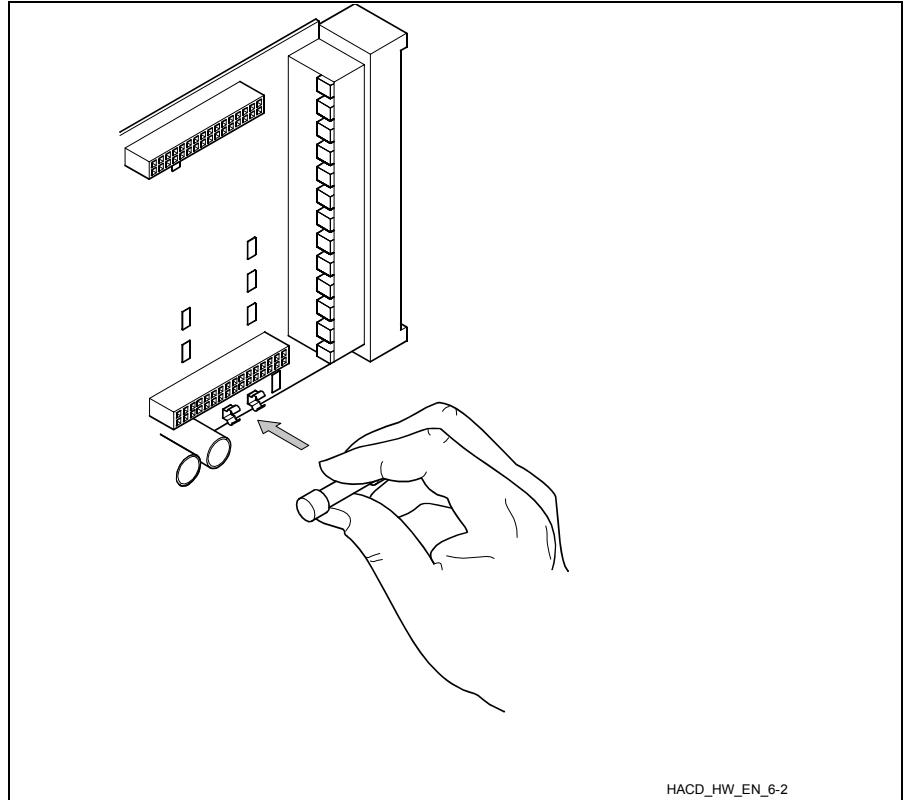

Fig. 9 Fuse on the HACD-DPC Controller Card

- ▶ Use a suitable test device to check the fuse. (continuity test)
- ▶ If the fuse is defective, replace it with the same type.
- ▶ Reinstall the HACD-DPC controller card and perform a functional test.

Notes

7 Index

Action symbol	5	Parameter changing	29
Analog GND.....	15	Password.....	26
Analog input.....	15	Power cables.....	10
BODAC setup routine	19	Reference voltage	15
BODAC software	19	Result symbol.....	5
Characters	5	Run mode.....	28
compatible	14	Running text	28, 29
Configuration mode	28	Safety fuse	34
Control card		Safety requirements	4
Installation	13	Sensor lines.....	10
Control parameter		Serial port.....	22
CMD-LFB <	24	Setpoint parameter	
CMD-LFB >	24	Acceleration.....	24
D 24		Delay	24
D (LFB1).....	24	Setpoint	24
I 24		Speed-.....	24
P 24		Speed+	24
T1 24		Shield	10
Diagnostics terminal	23, 32	Shielding.....	10
Diagnostics using BODAC	32	Sprache/Language	26
Differential inputs	10	Supply GND	16
Display	22	Supply voltage.....	16
DOWN	27	Symbols.....	5
Drives		System ground	10
Electromechanical and electrohydraulic	5	Transport.....	12
EC Directive 89/392/EWG (Machine Directive)8		Troubleshooting.....	11
Edge connector.....	14	UP 27	
EMC Regulations.....	8	Warning symbol	
ENTER.....	27	Equipment damage	6
Error conditions.....	32	Hazard potential, electrical current.....	5
Error messages	34	Hazard potential, general	5
ESCAPE	27		
Front panel.....	13		
Fuse.....	34		
HACD.....	32		
Initial startup	32		
Installation.....	10		
Installation requirements.....	19		
Keys.....	27		
LED's for digital in-/outputs	22		
Link/Controller.....	25		
Menu tree			
Parameters Part 1	24		
Parameters Part 2	25		
Setup	26		
Noise sources	10		
Output compensation			
Overlap.....	25		
Residual speed.....	25		

Bosch Rexroth AG
Hydraulics
Zum Eisengießer 1
97816 Lohr, Germany
info@boschrexroth.de
www.boschrexroth.com

© This document, as well as the data, specifications and other information set forth in it, are the exclusive property of Bosch Rexroth AG. It may not be reproduced or given to third parties without its consent.

The data specified above only serve to describe the product. No statements concerning a certain condition or suitability for a certain application can be derived from our information. The information given does not release the user from the obligation of own judgment and verification. It must be remembered that our products are subject to a natural process of wear and aging.

Printed in Germany
RE 30147-B/08.07
Replaces: 11.06