



OIL SOLUTIONS

PO Box 38
Strathfieldsaye, VIC, 3551
1800 OIL SOL
1800 645 765

sales@oilsolutions.com.au

www.oilsolutions.com.au

"For All Your Hydraulic Needs"

Off-line cooler

BNK

Installation and Operation Instructions

Original instructions





Bühler Technologies GmbH, Harkortstr. 29, D-40880 Ratingen
Tel. +49 (0) 21 02 / 49 89-0, Fax: +49 (0) 21 02 / 49 89-20
Internet: www.buehler-technologies.com
E-Mail: fluidcontrol@buehler-technologies.com

Read this instruction carefully prior to installation and/or use. Pay attention particularly to all advises and safety instructions to prevent injuries. Bühler Technologies can not be held responsible for misusing the product or unreliable function due to unauthorised modifications.

All rights reserved. Bühler Technologies GmbH 2022

Document information

Document No.....BE360001
Version.....04/2022



1800-OILSOL
1800-645765

<https://oilsolutions.com.au/>

sales@oilsolutions.com.au

Contents

1	Introduction.....	2
1.1	Intended use	2
1.2	Model key.....	2
1.3	Scope of delivery.....	2
2	Safety instructions.....	3
2.1	Important advice.....	3
2.2	General hazard warnings	4
3	Transport and storage	5
4	Installation and connection	6
4.1	Requirements to the installation site.....	6
4.2	Installing the unit.....	6
4.2.1	Additional advices for units with pump	6
4.2.2	Installing swivel nuts in the fitting body	7
4.3	Hydraulic connection	7
4.4	Electrical connections	8
5	Operation and control	9
5.1	Before starting	9
5.2	During starting	9
6	Maintenance.....	10
6.1	Cleaning and disassembly of the cooler matrix	11
6.2	Cleaning the cooler matrix inside	12
6.3	Cleaning the fan case.....	12
6.4	Replacing fan parts.....	12
7	Service and repair.....	13
7.1	Troubleshooting	13
8	Disposal	14
9	Appendices	15
9.1	Technical data	15
9.1.1	Basic data (at 50 Hz frequency)	16
9.2	Dimensions	17
9.3	Functional diagram	19
9.4	Installation torques and clamping range for cable fitting	20
9.5	Screw torques	20
9.6	Hose torques	20
9.7	Calculations	20
9.7.1	Calculating viscosity	20
9.7.2	Table of operational viscosity for VG oil	21
9.7.3	Calculating the pressure loss	21
9.8	Pressure loss in straight pipes.....	21
10	Attached documents	23



1 Introduction

1.1 Intended use

BNK off-line coolers are suited for transportation and air cooling of oils in hydraulic and lubrication systems. Their scope is given by their specifications. The use in other applications is not permitted without confirmation by Bühler Technologies GmbH.

1.2 Model key

BNK 4.4-30-0.75kW- IBx

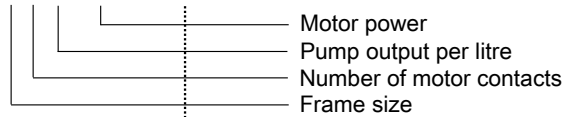

To also have a bypass, the specification will be added to the type designation:

BNK 4.4-30-0.75kW- IBx

Bypass version	AB	(BNK 2-8)	external bypass
	IB	(BNK 3-8)	internal bypass
	ITB	(BNK 3-8)	internal temperature-dependent bypass 2 bar / 45 °C
	ATB	(BNK 2-8)	external temperature-dependent bypass 2 bar / 45 °C
	x		bypass value 2 bar, 5 bar, 8 bar

1.3 Scope of delivery

- 1 x Off-line cooler
- Product documentation



1800-OILSOL
1800-645765

<https://oilsolutions.com.au/>

sales@oilsolutions.com.au

2 Safety instructions

2.1 Important advice

Operation of the device is only permitted if:

- the product is used under the conditions described in the installation- and operation instruction, the intended application according to the type plate and the intended use. In case of unauthorized modifications done by the user Bühler Technologies GmbH can not be held responsible for any damage,
- when complying with the specifications and markings on the nameplates.
- the performance limits given in the datasheets and in the installation- and operation instruction are obeyed,
- monitoring devices and safety devices are installed properly,
- service and repair is carried out by Bühler Technologies GmbH,
- only original spare parts are used.

This manual is part of the equipment. The manufacturer keeps the right to modify specifications without advanced notice. Keep this manual for later use.

Signal words for warnings

DANGER	Signal word for an imminent danger with high risk, resulting in severe injuries or death if not avoided.
WARNING	Signal word for a hazardous situation with medium risk, possibly resulting in severe injuries or death if not avoided.
CAUTION	Signal word for a hazardous situation with low risk, resulting in damaged to the device or the property or minor or medium injuries if not avoided.
NOTICE	Signal word for important information to the product.

Warning signs

In this manual, the following warning signs are used:

	Warning against hazardous situations		Warning against high pressure
	Warning against electrical voltage		Warning against potentially explosive atmospheres
	Warning against hot surface		General notice
	Warning against environmental hazard		Disconnect from mains
	Warning against rotating parts		Wear protection gloves



1800-OILSOL
1800-645765

<https://oilsolutions.com.au/>

sales@oilsolutions.com.au

2.2 General hazard warnings

The equipment must be installed by a professional familiar with the safety requirements and risks.

Be sure to observe the safety regulations and generally applicable rules of technology relevant for the installation site. Prevent malfunctions and avoid personal injuries and property damage.

The operator of the system must ensure:

- Safety notices and operating instructions are available and observed,
- The respective national accident prevention regulations are observed,
- The permissible data and operational conditions are maintained,
- Safety guards are used and mandatory maintenance is performed,
- Legal regulations are observed during disposal,
- compliance with national installation regulations.
- Nearby equipment is EMC protected, e.g. through shielding.
- The current and voltage supply for the aggregate has a (mains) separator with adequate switching capacity. National requirements must be observed.

Maintenance, Repair

Please note during maintenance and repairs:

- Repairs to the unit must be performed by Bühler authorised personnel.
- Only perform conversion-, maintenance or installation work described in these operating and installation instructions.
- Always use genuine spare parts.
- Do not install damaged or defective spare part. If necessary, visually inspect prior to installation to determine any obvious damage to the spare parts.

Always observe the applicable safety and operating regulations in the respective country of use when performing any type of maintenance.

DANGER

Electrical voltage



Electrocution hazard.

- a) Disconnect the device from power supply.
- b) Make sure that the equipment cannot be reconnected to mains unintentionally.
- c) The device must be opened by trained staff only.
- d) Regard correct mains voltage.



CAUTION

Hot surface



Burning hazard

Let the device cool down before maintaining.

CAUTION

High pressure



Hazard of injury due to flung off parts or oil, environmental hazard due to oil.

- a) Before starting any maintenance or repair to the oil circuit, make sure that the device is depressurized. This applies to the threaded plugs as well.
- b) Avoid environmental pollution (oil spills) during cleaning or maintenance of the oil circuit.
- c) Use drip pans.

DANGER

Potentially explosive atmosphere



Explosion hazard if used in hazardous areas.

The device is not suitable for operation in hazardous areas with potentially explosive atmospheres.

3 Transport and storage

Only transport the product inside the original packaging or a suitable alternative. Ensure secure fastening and mooring.

Air coolers have M10 eye bolts at the top of the cooler housing for transport. Please note, due to the variety of versions the mounting bracket is not located at the exact centre of gravity and the cooler may swing when hoisted. Never hoist the complete cooler by the M8 threads in the cooling elements!

Only use the motor transport eyes to hoist the motor without add-ons.

Do not use the eye bolts according to DIN 580 in ambient temperatures below -20 °C. The eye bolts could fracture in these temperatures, injuring personnel and/or damage the system.

Do not strain the eye bolts more than 45° in the thread direction.

When not in use, the equipment must be protected from moisture and heat. It must be stored in a covered, dry, dust-free room at room temperature.

WARNING



Crushing hazard

Crushing hazard during equipment transport and set-up.
Use the correct hoisting gear to prevent injuries during hoisting.
Be sure the hoisting gear is free from defects and approved for the weight of the device.
Ensure secure fastening and mooring when transporting.

4 Installation and connection

4.1 Requirements to the installation site

Aggregate

The aggregate must be set up to allow for unobstructed air flow and adequate room for maintenance/repairs. When installed outdoors, be sure to consider the motor protection rating (standard: IP 55) and ensure adequate protection from the weather.

Air cooler

The aggregate must be set up to allow for unobstructed air flow and adequate room for maintenance/repairs.

The cooler must be located in such a way that the air flowing through the matrix has free flow on entry and exit. The distance between air intake or air outlet to the nearest surrounding obstacle should be at minimum half the height of the matrix. Free air flow must be provided. If the cooler is to be sited near to working personnel, the effect of hot draught and noise emissions must be taken into account.

If the cooler is installed in closed space, ensure sufficient air circulation. Avoid back flow of warmed air. If necessary, the room must be vented.

Due to lower temperatures with respect to closed rooms, the cooling capacity outside raises, but on the other hand higher start up pressure may result due to higher oil viscosity. In this case, consider a bypass valve and / or a heating.

The rotating fan might lead to static charging. Therefore sensitive equipment like electronics should be kept away from the device.

4.2 Installing the unit

The units are screwed in place at the attachment points using screws. Be sure the support structure is sized adequately. To protect the system from damage, the connections must be stress free. We recommend using flexible hoses. Be sure the hose is stable against negative pressure, e.g. steel wire reinforced. Avoid possible leaks in the circuit to prevent environmental damages. If necessary, use an oil pan. Protect the aggregate from mechanical impact.

4.2.1 Additional advices for units with pump

The distance from the unit to the reservoir should be as short as possible. Especially the suction pipe should be short and of sufficient inner diameter.

We suggest mounting the unit in the same height as the liquid level. Mounting below the liquid level is possible as well.

If the aggregate can only be installed above this level, the pump will have a constant suction pressure of 0.4 bar (atmosphere). Depending on the oil viscosity and temperature, this will result in a different suction lift. A difference in value of 2 m can be used as a guide.

Until the oil is heated to operating temperature, a suction pressure of 0.6 bar is permissible temporarily.

The diameter of the intake pipe should not be smaller than specified in the data sheet. We recommend a max. flow speed of 1.5 m/s.

When first starting up a hydraulic system with a long intake pipe can cause problems due to excess air in the intake pipe. In this case we suggest filling the suction pipe with oil and using a suction valve without spring.

Oil is sprayed into the pump housing during the assembly process at our factory. This is necessary to seal the gerotor from the housing with an oil film. During extended periods of storage the pump housing may not have enough oil anymore to create this oil film when switching on the pump. The pump may then completely lose suction. Before connecting the suction pipe we recommend spraying some oil into the pump housing to prevent this.

The pump may be exposed to max. 0.5 bar of pressure on the suction side.



4.2.2 Installing swivel nuts in the fitting body

Proceed as follows:

- Carefully slide the preinstalled pipe end into the 24° cone on the fitting body.
- Tighten the swivel nut until a considerable increase in force can be felt (fixed point).
- Use a suitable spanner to tighten the swivel nut a 1/12 turn more (30°) beyond the fixed point. A marker line on the swivel nut and the fitting body facilitates observing the correct tightening angle.

Tube A.D.	Thread	Torque (Nm) for straight screwed plug	Torque (Nm) sealing plug
6	G 1/8"	18	13
8	G 1/4"	35	30
10	G 1/4"	35	30
12	G 3/8"	70	60
15	G 1/2"	90	80
18	G 1/2"	90	80
22	G 3/4"	180	140
28	G 1"	310	200
35	G 1 1/4"	450	400
42	G 1 1/2"	540	450

4.3 Hydraulic connection

Carry out the hydraulic connection as described in the attached data. Connect the lines stress and vibration free, so typically using hoses.

Be sure to use suitable lines (with regard to pressure, fluid resistance, environmental influences, fire) when connecting to the hydraulic-, lubrication circuit. Tighten the hose lines with a suitable torque (see appendix).

Contaminated fluids impact the life of the cooling system, we therefore recommend a purity class of 23/19/13 per ISO 4406.

If your hydraulic system is equipped with control or shut-off valves, we recommend protecting the cooling system with a pressure relief valve. No pressure relief valves are factory installed in the cooler.

The coolers are optionally available with external or internal bypass valve in the cooling matrix.



4.4 Electrical connections

CAUTION

Electrical voltage

Wrong mains voltage may damage the device.

Installation of the device shall be performed by trained staff only. Regard the voltage given on the type plate. Make sure that the cables have sufficient strain relief.

Fusing

Fusing has to be done due to local standards!

Polarity

Take care of the directional rotation of the motor. The fan rotates counter clockwise when regarded from the motor's side!

Watch the direction arrow on the sticker.

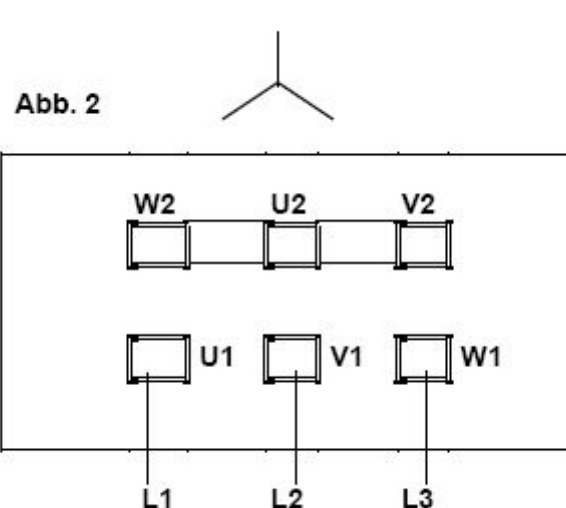
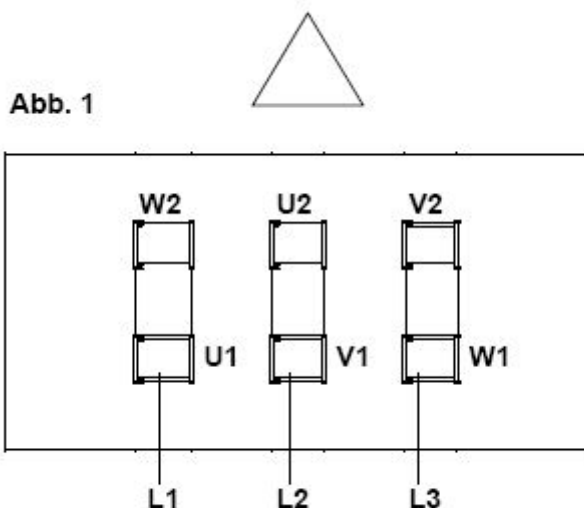

The direction of rotation can be changed by reversing any two phases.

Use the applicable local regulations to determine the safety values and the cross-sections of connection leads. The motor and, if equipped, starting devices must be connected to protective earth.

Lead fuses protect the cables in case of a short circuit, but are not sufficient to protect the motor coils from burning due to overload. Therefore, install an adequate motor circuit breaker with high precision range of adjustment for thermal protection to protect the motor against overload and operation with two phases

Adjust the motor circuit breaker according to the nominal value specified on the type plate of the motor. Operation outside the specified mains voltage and frequency range limits is prohibited.

Take appropriate measures to protect energised parts from being touched by persons and/or interference from foreign objects.

The operator of the equipment is responsible for ensuring lightning protection.

Connect the protective earth of the motor to the protective earth on site. Protective earth per DIN VDE 0100 must be connected to the marked earth lead terminal.

5 Operation and control

WARNING



Danger due to rotating fan

Injuries to the hand may occur. Do not reach into the safety guard!

NOTICE



The device must not be operated beyond its specifications.

NOTICE



Abrupt flow variation can lead to pressure peaks that may damage the cooler matrix. Make sure that the specifications are not exceeded in this case!

5.1 Before starting

- Check that all parts are free of damage, especially the cooling element and fan guard. Do not put a damaged device into operation.
- Check if the two warning labels (rotating parts) on the cooler's housing are fitted.
- Check the correct connections of oil and power circuits according to chapter „Installation and connection“.
- Make sure that all valves or other parts in the cooling circuit, which have to be opened, are opened.

5.2 During starting

First, check that the motor is proper electrically connected and the fan rotates counter clockwise when looking from the motor's side.

CAUTION



Hot surface

Burning hazard
Let the device cool down before maintaining.

CAUTION



High pressure

Hazard of injury due to flung off parts or oil, environmental hazard due to oil.

- Before starting any maintenance or repair to the oil circuit, make sure that the device is depressurized. This applies to the threaded plugs as well.
- Avoid environmental pollution (oil spills) during cleaning or maintenance of the oil circuit.
- Use drip pans.

Noise level

The coolers, which are supplied with an additional circulation pump, have a low noise. If the noise level increases significantly over the listed value, this could be caused through improper installation of the cooler, specially of the suction line. The technical consultants from Bühler Technologies GmbH will be happy to assist you.



1800-OILSOL
1800-645765

<https://oilsolutions.com.au/>

sales@oilsolutions.com.au

6 Maintenance

During maintenance, remember:

- The equipment must be maintained by a professional familiar with the safety requirements and risks.
- Only perform maintenance work described in these operating and installation instructions.
- When performing maintenance of any type, observe the respective safety and operation regulations.

DANGER

Electrical voltage

Electrocution hazard.



- Disconnect the device from power supply.
- Make sure that the equipment cannot be reconnected to mains unintentionally.
- The device must be opened by trained staff only.
- Regard correct mains voltage.



CAUTION

Hot surface



Burning hazard

Let the device cool down before maintaining.

CAUTION

High pressure



Hazard of injury due to flung off parts or oil, environmental hazard due to oil.

- Before starting any maintenance or repair to the oil circuit, make sure that the device is depressurized. This applies to the threaded plugs as well.
- Avoid environmental pollution (oil spills) during cleaning or maintenance of the oil circuit.
- Use drip pans.

Under normal operating conditions the aggregates are maintenance free. Preventive maintenance must therefore be routinely carried out by the operating company.

When doing so, please pay attention to:

- Tight screw fittings,
- Tightness,
- Damage to the aggregate (replace damaged parts),
- Abnormal (unusual) noise and vibration,
- Cooler matrix cleanliness. Dirt on the cooler matrix reduces the cooling capacity,
- Check warning labels for legibility and damage.

Electrical connections must be checked annually by a licensed electrician.

The external parts the motors, particularly the cooling ribs and cooling ducts as clean as possible to prevent compromising heat release.

Please note the specified protection against dust and moisture. Pressure cleaning is only permitted if the motor has the respective protection rating.

The motors feature ball bearings sealed on both sides. The grease filling is designed to last for the life of the unit. Greasing is not necessary.

The motor mounts may only be replaced by Bühler Technologies GmbH or a qualified specialist company.



1800-OILSOL
1800-645765

<https://oilsolutions.com.au/>

sales@oilsolutions.com.au

Condensate drain holes at motors from manufacturer WEG

If the motor is used in surrounding with high humidity this could lead, depending on the ambient temperature, to formation of condensate inside the motor housing. Specially at longer nonoperation period. The motors of WEG have a condensate drain plug which can be used for draining off. Pull out the plug according to the pictures and push it then back. If the plug is not pushed back or completely removed, the motor loses the IP degree of protection.

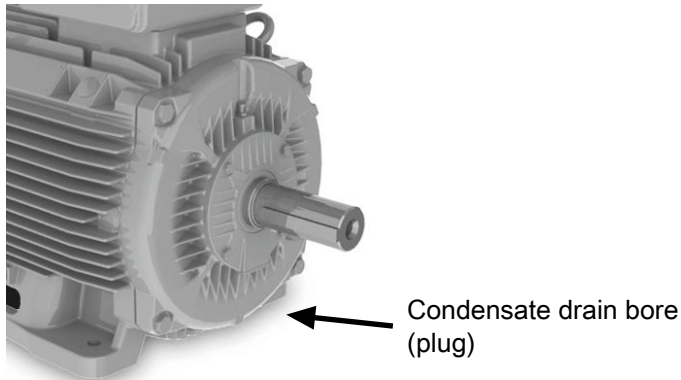

closed position

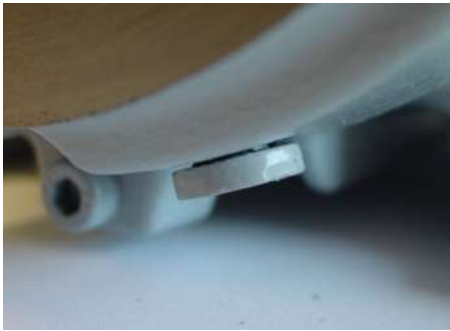

open position



plug



6.1 Cleaning and disassembly of the cooler matrix

Due to the design of the cooling fins, the cooler has low susceptibility to dust and dirt. Normally, it is sufficient to clean the front surface with a brush. If the ambient air is loaded with higher amounts of oil or dust, it may be necessary to clean the cooling matrix in regular intervals.

- First, let the cooling matrix cool down. Then disconnect the motor from the mains and secure it against reconnecting.
- Depressurize the system and disconnect the piping. Place an oil drip pan below the cooling matrix to collect leaking oil.
- Close all connections with plugs to avoid further oil leakage.
- Protect the cooling matrix from falling down.
- Dismantle the cooling matrix from the fan case by loosening the 4 fastening bolts. The cooler sizes 6 up to 8 provide threads for eyebolts in the cooler matrix for lifting with hoisting devices.
- Take it to the cleaning area. Be careful not to damage the fins during transport and cleaning.
- Clean the matrix by blowing pressurized air from the rear side through the fin rows in parallel.
- If dirt is wet and sticky, carefully use high pressure cleaner and/or some washing agent. In this case, rinse the cooler matrix with pure water.
- Remount the cooling matrix in reverse order.
- Regard correct mounting of the connecting sleeves.

6.2 Cleaning the cooler matrix inside

In the event of deposits in the cooling matrix due to inadequate filtration, you may try to remove these as follows after cleaning the outside:

- Remove the cooler matrix as described in “Cooler matrix cleaning and disassembly”.
- Add degreaser and close all connections of the cooler matrix with plugs.
- After allowing the degreaser to sit for a while, drain and flush the cooler matrix with clean fluid. Dispose of the degreaser and flushing oil as required by law.
- After cleaning, remount the cooler matrix in reverse order.

6.3 Cleaning the fan case

Due to the design, dust and dirt will not deposit in a large amount inside the fan case. Nevertheless, any deposits of dirt should be blown out each time the cooler is cleaned.

6.4 Replacing fan parts

- Disconnect the motor from the mains and protect it from being re-connected unintentionally.
- Now remove the mains cable.
- There are two different fan models.
- Model with fixed fan hub, the fan can be replaced only together with the hub.
- Models with separated hub and fan, the fan can be replaced without replacing the hub.

Models with motor support and mounting brackets:

- Secure the fan unit against falling.
- Unscrew the four fixing bolts at the case on top of the mounting brackets.
- Unscrew the four screws connecting the fan unit to the housing at the tips of the fan guard.
- The fan unit can now be pulled out carefully to the back.
- Remount the new fan in reverse order. If the fan is replaced, insert the screw adding with glue at the motor shaft.

Models with motor support and elongated holes in the mounting rails:

- Secure the fan unit against falling.
- Unscrew the screws fixing the support to the coolers feet about two revolutions.
- Unscrew the four screws connecting the fan unit to the housing at the tips of the fan guard.
- The fan unit can now be pulled out carefully to the back.
- Remount the new fan in reverse order. If the fan is replaced, insert the screw adding with glue at the motor shaft.



7 Service and repair

This chapter contains information on troubleshooting and correction should an error occur during operation.

Repairs to the unit must be performed by Bühler authorised personnel.

Please contact our Service Department with any questions:

Tel.: +49-(0)2102-498955 or your agent

If the equipment is not functioning properly after correcting any malfunctions and switching on the power, it must be inspected by the manufacturer. Please send the equipment inside suitable packaging to:

Bühler Technologies GmbH

- Reparatur/Service -

Harkortstraße 29

40880 Ratingen

Germany

Please also attach the completed and signed RMA decontamination statement to the packaging. We will otherwise be unable to process your repair order.

You will find the form in the appendix of these instructions, or simply request it by e-mail:

service@buehler-technologies.com.

7.1 Troubleshooting

Problem / Failure	Possible cause	Solution
Cooling capacity not sufficient	– Ambient air temperature is higher than specified	– Select larger model
	– Motor's rotation direction wrong	– Correct connection, see Electrical connections
	– Motor doesn't start	– Correct connection, see Electrical connections
	– Air flow too low	– Correct connection, see Electrical connections
	– Air fins clogged	– Clean cooler matrix, see Maintenance
	– Near obstacles	– Regard minimum distance
	– Oil flow too low	– Increase oil flow
	– Oil channel clogged	– Cleaning, see chapter Cleaning the cooler matrix inside
	– Oil circuit blocked	– Open valves and cocks
	– Suction pressure to high, therefore reduced oil flow.	– Select suction hose with sufficient diameter – Reduce suction height
No oil flow	– Not enough oil inside pump housing due to long standstill or storage, therefore no suction.	– Refill some oil into the pump housing before connecting the suction hose
Pump too noisy	– Suction pressure too high	– Select suction hose with sufficient diameter
		– Reduce suction height

Tab. 1: Troubleshooting



1800-OILSOL
1800-645765

<https://oilsolutions.com.au/>

sales@oilsolutions.com.au

8 Disposal

Dispose of the parts in such a way that does not present a danger to other people's health or to the environment. Observe the legal requirements in the country of use for the disposal of electrical components and oils and coolants.



1800-OILSOL
1800-645765

<https://oilsolutions.com.au/>

sales@oilsolutions.com.au

9 Appendices

9.1 Technical data

Technical Data

Materials/surface protection

Cooling matrix:	Aluminium, painted
ventilation box, safety guard and motor brackets:	Steel, powder-coated
Pump:	anodised aluminium, sintered steel

Colour: RAL 7001

Operating fluids: Mineral oils per DIN 51524
Gear oil per DIN 51517-3

Operating pressure, static: 8/16/29/42 L/min – max. 6 bar
58/88 L/min – max. 8 bar

Suction pressure: max. - 0.4 bar

Operating oil temperature: max. 80 °C (higher upon request)

max. viscosity: 100 cSt medium viscosity (higher upon request)

Ambient temperature: -15 to +40 °C

Electric motors (others available upon request)

Voltage / frequency: 220/380V – 230/400V – 240/415V 50Hz
460 60 Hz

Thermal stability: Insulation class F,
utilisation per Class B

Protection class: IP55

The motors comply with standards
IEC 60034, IEC 60072, IEC 60085



1800-OILSOL
1800-645765

<https://oilsolutions.com.au/>

sales@oilsolutions.com.au

9.1.1 Basic data (at 50 Hz frequency)

Item no.	Cooler model	spec. cooling capacity kW/K	Cooling capacity at ETD = 40 K (kW)	max. circulation rate (L/min)	Motor power Number of motor contacts Rated current at 400 V	Weight (kg)	Volume (L)	Noise db(A)*
3601406IE3**	BNK 1.4-7,5-0,75kW	0,04	1,6	8	0,75 kW/4/1,62 A	30	0,7	64
3601401IE3**	BNK 1.4-15-0,75kW	0,05	2	16	0,75 kW/4/1,62 A	30	0,7	64
3602406IE3**	BNK 2.4-7,5-0,75kW	0,09	3,6	8	0,75 kW/4/1,62 A	37	1,3	66
3602401IE3**	BNK 2.4-15-0,75kW	0,11	4,4	16	0,75 kW/4/1,62 A	39	1,3	66
3602402IE3**	BNK 2.4-30-0,75kW	0,13	5,2	29	0,75 kW/4/1,62 A	40	1,3	66
3602407IE3**	BNK 2.4-40-1,1kW	0,14	5,6	42	1,1 kW/4/2,35 A	43	1,3	66
3603406IE3**	BNK 3.4-8-0,75kW	0,17	6,8	8	0,75 kW/4/1,62 A	46	1,8	71
3603401IE3**	BNK 3.4-15-0,75kW	0,20	8	16	0,75 kW/4/1,62 A	45	1,8	71
3603402IE3**	BNK 3.4-30-0,75kW	0,23	9,2	29	0,75 kW/4/1,62 A	45	1,8	71
3603407IE3**	BNK 3.4-40-1,1kW	0,25	10	42	1,1 kW/4/2,35 A	48	1,8	71
3604401IE3**	BNK 4.4-15-0,75kW	0,24	9,6	16	0,75 kW/4/1,62 A	53	2,3	73
3604402IE3**	BNK 4.4-30-0,75kW	0,30	12	29	0,75 kW/4/1,62 A	50	2,3	73
3604407IE3**	BNK 4.4-40-1,1kW	0,33	13,2	42	1,1 kW/4/2,35 A	54	2,3	73
3604403IE3**	BNK 4.4-60-1,5kW	0,35	14	58	1,5 kW/4/3,17 A	59	2,3	73
3604404IE3**	BNK 4.4-90-2,2kW	0,37	14,8	88	2,2 kW/4/4,56 A	74	2,3	73
3605403IE3**	BNK 5.4-60-2,2kW	0,55	22	58	2,2 kW/4/4,56 A	80	3,1	79
3605404IE3**	BNK 5.4-90-2,2kW	0,60	24	88	2,2 kW/4/4,56 A	81	3,1	79
3606413IE3**	BNK 6.4-60-3,0kW	0,90	36	58	3,0 kW/4/6,15 A	100	4,1	86
3606414IE3**	BNK 6.4-90-3,0kW	1,01	40,4	88	3,0 kW/4/6,15 A	101	4,1	86
3606613IE3***	BNK 6.6-60-2,2kW	0,65	26	58	2,2 kW/6/4,7 A	88	4,1	74
3607413IE3**	BNK 7.4-60-3,0kW	0,93	37,2	58	3,0 kW/4/6,15 A	110	5,4	89
3607414IE3**	BNK 7.4-90-3,0kW	1,04	41,6	88	3,0 kW/4/6,15 A	111	5,4	89
3607613IE3***	BNK 7.6-60-2,2kW	0,71	28,4	58	2,2 kW/6/4,7 A	98	5,4	75
3608613IE3**	BNK 8.6-60-3,0kW	1,10	44	58	3,0 kW/6/6,91 A	162	6,3	79

*DIN EN ISO 3744, Class 3

**Electr. motor per NEMA, UL, CSA, EAC approval

***Electr. motor per NEMA, UL, CUL approval



1800-OILSOL
1800-645765

<https://oilsolutions.com.au/>

sales@oilsolutions.com.au

9.2 Dimensions

BNK 1

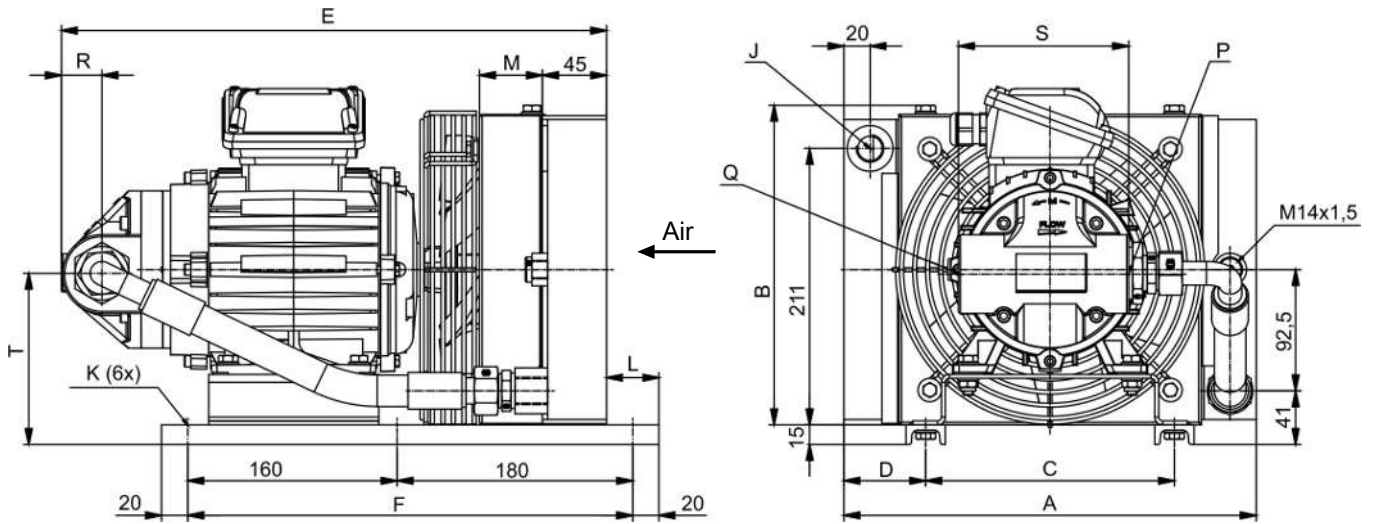

BNK 2-8

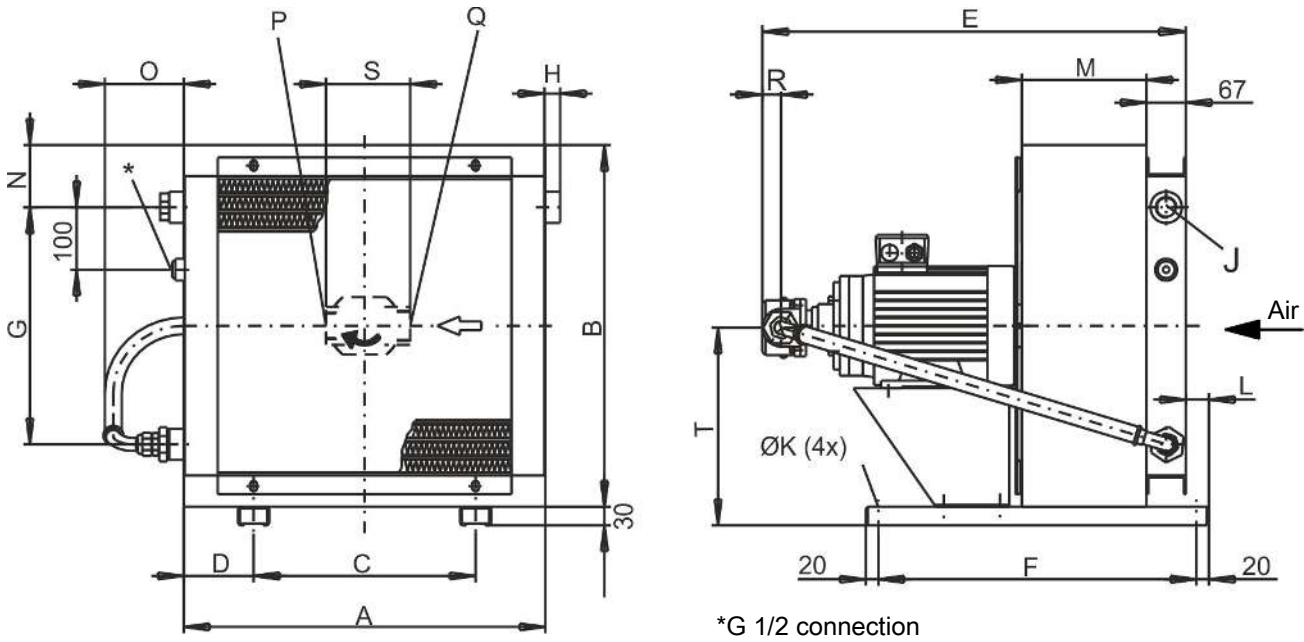

Model	A	B	C	D	E	F	G	H	J	K	L	M	N	O	P	Q	R	S	T
BNK 1.4-7,5-0,75kW	315	243	190	62,5	417	340	-	-	2x G 1/2	9	40	52	-	-	G1	G3/4	30	144	130
BNK 1.4-15-0,75kW	315	243	190	62,5	417	340	-	-	2x G 1/2	9	40	52	-	-	G1	G1 1/4	30	130	130
BNK 2.4-7,5-0,75kW	370	370	203	83,5	476	510	-	25	2x G1	9	33	125	106	119	G1	G3/4	30	130	212
BNK 2.4-15-0,75kW	370	370	203	83,5	476	510	-	25	2x G1	9	33	125	106	119	G1	G1 1/4	30	130	212
BNK 2.4-30-0,75kW	370	370	203	83,5	474	510	-	25	2x G1	9	33	125	106	119	G1	G1 1/4	30	130	212
BNK 2.4-40-1,1kW	370	370	203	83,5	494	510	-	25	2x G1	9	33	125	106	119	G1	G1 1/4	30	130	212
BNK 3.4-8-0,75kW	440	440	203	118,5	501	510	230	25	3x G1	9	33	150	105	119	G1	G3/4	30	130	247
BNK 3.4-15-0,75kW	440	440	203	118,5	501	510	230	25	3x G1	9	33	150	105	119	G1	G1 1/4	30	130	247
BNK 3.4-30-0,75kW	440	440	203	118,5	499	510	230	25	3x G1	9	33	150	105	119	G1	G1 1/4	30	130	247
BNK 3.4-40-1,1kW	440	440	203	118,5	520	510	230	25	3x G1	9	33	150	105	119	G1	G1 1/4	30	130	247
BNK 4.4-15-0,75kW	500	500	203	148,5	526	510	230	25	3x G1	9	33	175	104	119	G1	G1 1/4	30	130	277
BNK 4.4-30-0,75kW	500	500	203	148,5	524	510	230	25	3x G1	9	33	175	104	119	G1	G1 1/4	30	130	277
BNK 4.4-40-1,1kW	500	500	203	148,5	546	510	230	25	3x G1	9	33	175	104	119	G1	G1 1/4	30	130	277
BNK 4.4-60-1,5kW	500	500	203	148,5	610	510	230	25	3x G1	9	33	175	104	131	G1 1/4	G1 1/2	30	135	277
BNK 4.4-90-2,2kW	500	500	203	148,5	688	510	230	25	3x G1	9	33	175	104	131	G1 1/4	G1 1/2	53	135	277
BNK 5.4-60-2,2kW	580	580	356	112	678	510	305	23,5	3x G1	9	33	200	100	131	G1 1/4	G1 1/2	30	135	317
BNK 5.4-90-2,2kW	580	580	356	112	713	510	305	23,5	3x G1	9	33	200	100	131	G1 1/4	G1 1/2	53	135	319
BNK 6.4-60-3,0kW	700	700	356	172	737	510	410	9,5	3x G1 1/4	9	33	225	110	132	G1 1/4	G1 1/2	30	135	377
BNK 6.4-90-3,0kW	700	700	356	172	772	510	410	9,5	3x G1 1/4	9	33	225	110	132	G1 1/4	G1 1/2	53	135	377
BNK 6.6-60-2,2kW	700	700	356	172	751	510	410	9,5	3x G1 1/4	9	33	225	110	132	G1 1/4	G1 1/2	53	135	377
BNK 7.4-60-3,0kW	700	840	356	172	762	510	590	9,5	3x G1 1/4	9	33	250	91	132	G1 1/4	G1 1/2	30	135	447
BNK 7.4-90-3,0kW	700	840	356	172	797	510	590	9,5	3x G1 1/4	9	33	250	91	132	G1 1/4	G1 1/2	53	135	447
BNK 7.6-60-2,2kW	700	840	356	172	776	510	590	9,5	3x G1 1/4	9	33	250	91	132	G1 1/4	G1 1/2	53	135	447
BNK 8.6-60-3,0kW	870	870	508	181	854	665	585	11	3x G1 1/4	9	33	275	101,5	133	G1 1/4	G1 1/2	53	135	462



1800-OILSOL
1800-645765

<https://oilsolutions.com.au/>

sales@oilsolutions.com.au

9.3 Functional diagram

Standard version BNK 2

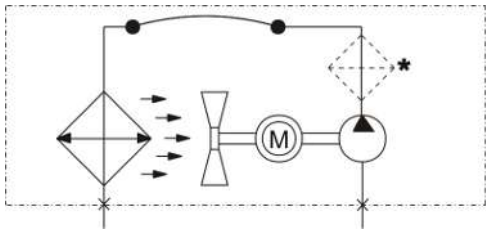

* recommended position of additional oil filter

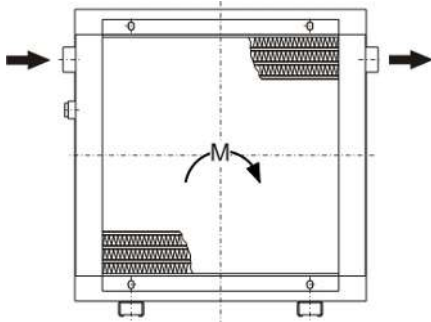

The oil inlet is on the left of the cooling battery. The oil outlet is always on the opposite side.

Standard version BNK 1, 3 to BNK 8

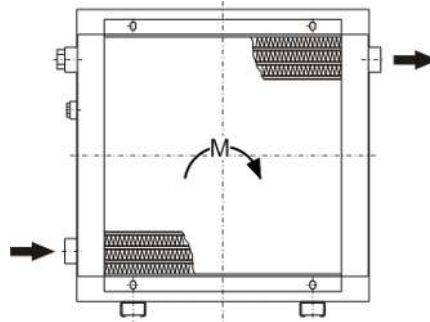
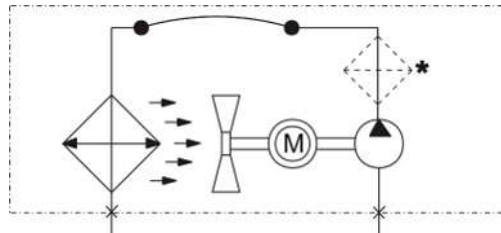

The oil inlet is on the bottom left of the cooling battery. The second connection at the top must be closed. The oil outlet is always on the opposite side.

Internal bypass IB/ ITB (BNK 3-8)

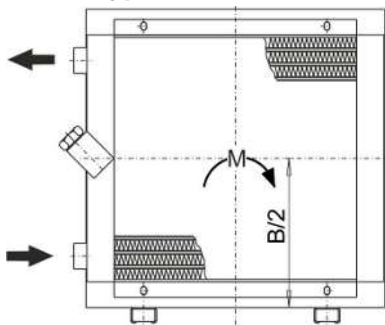

The oil inlet and outlet is always on the same side of the cooling battery. The connection on the opposite side must be closed.

External bypass AB/ATB (BNK 2-8)

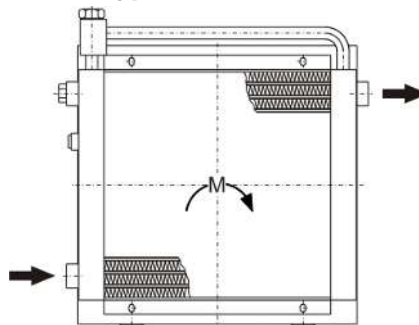

The oil inlet is always at the bottom left of the cooling battery. The second connection must be closed. The oil outlet is always on the opposite side.

With bypass valve

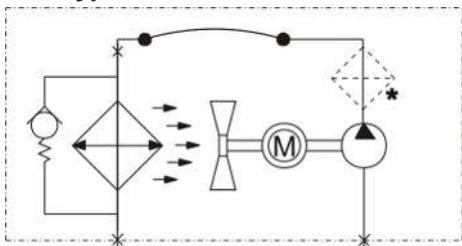

With temperature-dependent bypass valve

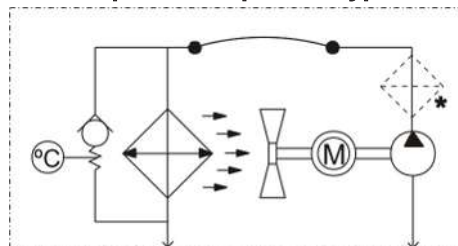

9.4 Installation torques and clamping range for cable fitting

Size	Strain relief clamping range (mm)	Installation torque (Nm)
M12x1,5	3-6	1,5
M16x1,5	5-9,5	2,5
M20x1,5	8-13	3,5
M25x1,5	11-17	5
M32x1,5	15-21	5
M40x1,5	19-28	7,5
M50x1,5	27-35	7,5
M63x1,5	32-42	13

9.5 Screw torques

Thread	Torque (Nm)
M5	4
M6	8
M8	15
M10	30
M12	51

9.6 Hose torques

Connections/mounts	Torque (Nm)
Hose connections DN20	180
Hose connections DN25	250
Hose connections DN32	350

9.7 Calculations

9.7.1 Calculating viscosity

Valid for VG-oil between 10 - 100 °C at an exactness from ± 5 %.

Definitions
 V_{40} oil viscosity at 40 °C in cst
 T temperature in °C
 ν viscosity in cst

Example: oil VG 46
 V_{40} 46 cst
 T 25 °C

$$b = 159 \cdot \ln \frac{V_{40}}{0,23}$$

$$b = 159 \cdot \ln \frac{46}{0,23} = 842,4325$$

$$a = 0,23 \cdot e^{\frac{-b}{877}}$$

$$a = 0,23 \cdot e^{\frac{-842,4325}{877}} = 0,08801$$

$$\nu = a \cdot e^{\frac{b}{T+95,2}}$$

$$\nu = 0,08801 \cdot e^{\frac{842,4325}{25+95,2}} = 97,35 \text{ cst}$$



9.7.2 Table of operational viscosity for VG oil

	10 °C	20 °C	30 °C	40 °C	50 °C	60 °C	70 °C	80 °C	90 °C
VG 46	264,45	131,96	73,58	46,00	29,13	20,04	14,43	10,78	8,32
VG 68	444,77	210,85	112,61	68,00	41,63	27,86	19,58	14,32	10,84
VG 220	2.120,17	861,60	404,31	220,00	121,71	74,99	49,00	33,61	24,01
VG 320	3.489,92	1.350,22	607,96	320,00	171,40	102,85	65,66	44,12	30,94

Viscosity given in cst (mm²/s)

9.7.3 Calculating the pressure loss

Valid for smooth straight piping per meter at laminar current.

	Definitions		Example: oil VG 46
ν	Viscosity in cst	ν	97,35 cst
ρ	spec. gravity in kg/dm ³	ρ	0,8817 kg/dm ³
DN	tube diameter in mm	DN	20 mm
V	flow in m/s	V	3,18 m/s (60 l/min for tube DN 20)
PV	pressure loss in bar		
	$PV = \frac{0,32 \cdot \nu \cdot \rho \cdot V}{DN^2}$		$PV = \frac{0,32 \cdot 97,35 \cdot 0,8817 \cdot 3,18}{20^2} = 0,22 \text{ bar}$

NOTICE



Pressure loss increases significantly for bends and fittings. It might be necessary in some cases to determine the final shape of the suction line on site under specific conditions.

Please do not hesitate to contact us for help to calculate the pressure loss of the suction line for you specific application.

NOTICE



To avoid damage of the cooling system, make sure that the maximum pump pressure is not exceeded. High pressure may occur if the system is shut off or throttled at the pressure side.

9.8 Pressure loss in straight pipes

Pressure loss (bar) per metre in straight tubing with laminar flow of mineral oil:

BFP 8 8 l/min – DN 25

	VG 46	VG 68	VG 120	VG 160	VG 220	VG 320	VG 460	VG 680
10 °C	0.03	0.05	0.11	0.17	0.25	0.42	0.68	1.14
20 °C	0.02	0.03	0.05	0.07	0.10	0.16	0.25	0.40
30 °C	0.01	0.01	0.02	0.03	0.05	0.07	0.11	0.17
40 °C	0.01	0.01	0.01	0.03	0.03	0.04	0.05	0.08
50 °C	0.01	0.01	0.01	0.02	0.01	0.02	0.03	0.04

60 °C – 100 °C < 0.03 bar

BFP 15 16 l/min – DN 32

	VG 46	VG 68	VG 120	VG 160	VG 220	VG 320	VG 460	VG 680
10 °C	0.02	0.04	0.08	0.12	0.19	0.31	0.50	0.85
20 °C	0.01	0.02	0.04	0.10	0.08	0.12	0.19	0.30
30 °C	0.01	0.01	0.02	0.05	0.04	0.05	0.08	0.12
40 °C	0.01	0.01	0.01	0.01	0.02	0.03	0.04	0.06
50 °C	0.01	0.01	0.01	0.01	0.01	0.02	0.01	0.03

60 °C – 100 °C < 0.02 bar

BFP 30 28 l/min – DN 32

	VG 46	VG 68	VG 120	VG 160	VG 220	VG 320	VG 460	VG 680
10 °C	0.04	0.07	0.15	0.22	0.33	0.54	0.88	1.48
20 °C	0.02	0.03	0.06	0.09	0.13	0.21	0.33	0.52
30 °C	0.01	0.02	0.03	0.04	0.07	0.09	0.14	0.22
40 °C	0.01	0.01	0.02	0.02	0.03	0.05	0.07	0.10
50 °C	0.01	0.01	0.01	0.01	0.02	0.03	0.04	0.06

60 °C – 100 °C < 0.03 bar**BFP 60 57 l/min – DN 40**

	VG 46	VG 68	VG 120	VG 160	VG 220	VG 320	VG 460	VG 680
10 °C	0.03	0.06	0.12	0.18	0.28	0.45	0.74	1.24
20 °C	0.02	0.03	0.05	0.08	0.11	0.18	0.27	0.43
30 °C	0.01	0.01	0.03	0.04	0.05	0.08	0.12	0.18
40 °C	0.01	0.01	0.02	0.02	0.02	0.04	0.06	0.08
50 °C	0.01	0.01	0.01	0.01	0.02	0.02	0.03	0.05

60 °C – 100 °C < 0.03 bar**BFP 90 86 l/min – DN 40**

	LVG 46	VG 68	VG 120	VG 160	VG 220	VG 320	VG 460	VG 680
10 °C	0.05	0.09	0.19	0.27	0.42	0.68	1.11	1.87
20 °C	0.03	0.04	0.08	0.12	0.17	0.26	0.41	0.65
30 °C	0.02	0.02	0.04	0.06	0.08	0.12	0.18	0.27
40 °C	0.01	0.01	0.02	0.03	0.04	0.06	0.09	0.13
50 °C	0.01	0.01	0.01	0.02	0.02	0.03	0.05	0.07

60 °C – 100 °C < 0.04 bar**Note:** Values in blue exceed the suction operation limit of -0.4 bar.

1800-OILSOL
1800-645765

<https://oilsolutions.com.au/>

sales@oilsolutions.com.au

10 Attached documents

- Declaration of conformity KX350001
- RMA - Decontamination Statement



1800-OILSOL
1800-645765

<https://oilsolutions.com.au/>

sales@oilsolutions.com.au

EG-/EU Konformitätserklärung
EC/EU Declaration of Conformity



Hiermit erklärt Bühler Technologies GmbH,
dass die nachfolgenden Produkte den
wesentlichen Anforderungen der Richtlinie

2006/42/EG
(MRL)

in ihrer aktuellen Fassung entsprechen.

Die Produkte sind Maschinen nach Artikel 2 a).

Folgende Richtlinien wurden berücksichtigt:

*Herewith declares Bühler Technologies GmbH
that the following products correspond to the
essential requirements of Directive*

2006/42/EC
(MD)

in its actual version.

The products are machines according to article 2 (a).

The following directives were regarded:

2014/30/EU (EMV/EMC)
2014/35/EU (NSR/LVD)

Produkt / products: Öl-Luft Kühler / Oil/Air cooler
Öl-Nebenstromkühler / Offline Oil/Air cooler
Typ / type: BLK
BNK

Die Betriebsmittel dienen zur Kühlung beziehungsweise Förderung und Luftkühlung von Ölen in
Hydraulik-und Schmierkreisläufen.

*The equipment is suited for cooling respectively transportation and air cooling of oils in hydraulic and
lubrication systems.*

Das oben beschriebene Produkt der Erklärung erfüllt die einschlägigen
Harmonisierungsrechtsvorschriften der Union:

*The object of the declaration described above is in conformity with the relevant Union harmonisation
legislation:*

EN ISO 12100:2010
EN 55011:2009

EN 60204-1:2006
EN ISO 4413:2010

EN 61000-6-2:2005

Die alleinige Verantwortung für die Ausstellung dieser Konformitätserklärung trägt der Hersteller.
This declaration of conformity is issued under the sole responsibility of the manufacturer.

Dokumentationsverantwortlicher für diese Konformitätserklärung ist Herr Stefan Eschweiler mit
Anschrift am Firmensitz.

*The person authorised to compile the technical file is Mr. Stefan Eschweiler located at the company's
address.*

Ratingen, den 05.02.2019

Stefan Eschweiler
Geschäftsführer – *Managing Director*

Frank Pospiech
Geschäftsführer – *Managing Director*

KX 35 0001

Bühler Technologies GmbH, Harkortstr. 29, D-40880 Ratingen,
Tel. +49 (0) 21 02 / 49 89-0, Fax. +49 (0) 21 02 / 49 89-20
Internet: www.buehler-technologies.com



1800-OILSOL
1800-645765

<https://oilsolutions.com.au/>

sales@oilsolutions.com.au

RMA-Formular und Erklärung über Dekontaminierung

RMA-Form and explanation for decontamination



RMA-Nr./ RMA-No.

Die RMA-Nummer bekommen Sie von Ihrem Ansprechpartner im Vertrieb oder Service./ You may obtain the RMA number from your sales or service representative.

Zu diesem Rücksendeschein gehört eine Dekontaminierungserklärung. Die gesetzlichen Vorschriften schreiben vor, dass Sie uns diese Dekontaminierungserklärung ausgefüllt und unterschrieben zurücksenden müssen. Bitte füllen Sie auch diese im Sinne der Gesundheit unserer Mitarbeiter vollständig aus./ This return form includes a decontamination statement. The law requires you to submit this completed and signed decontamination statement to us. Please complete the entire form, also in the interest of our employee health.

Firma/ Company

Firma/ Company
Straße/ Street
PLZ, Ort/ Zip, City
Land/ Country

Gerät/ Device
Anzahl/ Quantity
Auftragsnr./ Order No.

Ansprechpartner/ Person in charge

Name/ Name
Abt./ Dept.
Tel./ Phone
E-Mail
Serien-Nr./ Serial No.
Artikel-Nr./ Item No.

Grund der Rücksendung/ Reason for return

- Kalibrierung/ Calibration Modifikation/ Modification
 Reklamation/ Claim Reparatur/ Repair
 andere/ other

bitte spezifizieren/ please specify

Ist das Gerät möglicherweise kontaminiert?/ Could the equipment be contaminated?

- Nein, da das Gerät nicht mit gesundheitsgefährdenden Stoffen betrieben wurde./ No, because the device was not operated with hazardous substances.
 Nein, da das Gerät ordnungsgemäß gereinigt und dekontaminiert wurde./ No, because the device has been properly cleaned and decontaminated.
 Ja, kontaminiert mit:/ Yes, contaminated with:



explosiv/
explosive



entzündlich/
flammable



brandfördernd/
oxidizing



komprimierte
Gase/
compressed
gases



ätzend/
caustic



giftig,
Lebensgefahr/
poisonous, risk
of death



gesundheitsge-
fährdend/
harmful to
health



gesund-
heitsschädlich/
health hazard



umweltge-
fährdend/
environmental
hazard

Bitte Sicherheitsdatenblatt beilegen!/ Please enclose safety data sheet!

Das Gerät wurde gespült mit:/ The equipment was purged with:

Diese Erklärung wurde korrekt und vollständig ausgefüllt und von einer dazu befugten Person unterschrieben. Der Versand der (dekontaminierten) Geräte und Komponenten erfolgt gemäß den gesetzlichen Bestimmungen.

This declaration has been filled out correctly and completely, and signed by an authorized person. The dispatch of the (decontaminated) devices and components takes place according to the legal regulations.

Falls die Ware nicht gereinigt, also kontaminiert bei uns eintrifft, muss die Firma Bühler sich vorbehalten, diese durch einen externen Dienstleister reinigen zu lassen und Ihnen dies in Rechnung zu stellen.

Should the goods not arrive clean, but contaminated, Bühler reserves the right, to commission an external service provider to clean the goods and invoice it to your account.

Firmenstempel/ Company Sign

Datum/ Date

Bühler Technologies GmbH, Harkortstr. 29, D-40880 Ratingen
Tel. +49 (0) 21 02 / 49 89-0, Fax: +49 (0) 21 02 / 49 89-20
E-Mail: service@buehler-technologies.com
Internet: www.buehler-technologies.com

rechtsverbindliche Unterschrift/ Legally binding signature

DE000011 01/2019



1800-OILSOL <https://oilsolutions.com.au/>
1800-645765

sales@oilsolutions.com.au



Die Analyse defekter Baugruppen ist ein wesentlicher Bestandteil der Qualitätssicherung der Firma Bühler Technologies.

Um eine aussagekräftige Analyse zu gewährleisten muss die Ware möglichst unverändert untersucht werden. Es dürfen keine Veränderungen oder weitere Beschädigungen auftreten, die Ursachen verdecken oder eine Analyse unmöglich machen.

Bei elektronischen Baugruppen kann es sich um elektrostatisch sensible Baugruppen handeln. Es ist darauf zu achten, diese Baugruppen ESD-gerecht zu behandeln. Nach Möglichkeit sollten die Baugruppen an einem ESD-gerechten Arbeitsplatz getauscht werden. Ist dies nicht möglich sollten ESD-gerechte Maßnahmen beim Austausch getroffen werden. Der Transport darf nur in ESD-gerechten Behältnissen durchgeführt werden. Die Verpackung der Baugruppen muss ESD-konform sein. Verwenden Sie nach Möglichkeit die Verpackung des Ersatzteils oder wählen Sie selber eine ESD-gerechte Verpackung.

Beachten Sie beim Einbau des Ersatzteils die gleichen Vorgaben wie oben beschrieben. Achten Sie auf die ordnungsgemäße Montage des Bauteils und aller Komponenten. Versetzen Sie vor der Inbetriebnahme die Verkabelung wieder in den ursprünglichen Zustand. Fragen Sie im Zweifel beim Hersteller nach weiteren Informationen.

Analysing defective assemblies is an essential part of quality assurance at Bühler Technologies.

To ensure conclusive analysis the goods must be inspected unaltered, if possible. Modifications or other damages which may hide the cause or render it impossible to analyse are prohibited.

Electronic assemblies may be sensitive to static electricity. Be sure to handle these assemblies in an ESD-safe manner. Where possible, the assemblies should be replaced in an ESD-safe location. If unable to do so, take ESD-safe precautions when replacing these. Must be transported in ESD-safe containers. The packaging of the assemblies must be ESD-safe. If possible, use the packaging of the spare part or use ESD-safe packaging.

Observe the above specifications when installing the spare part. Ensure the part and all components are properly installed. Return the cables to the original state before putting into service. When in doubt, contact the manufacturer for additional information.



1800-OILSOL
1800-645765

<https://oilsolutions.com.au/>

sales@oilsolutions.com.au

