



Heat exchangers BWT

Hydraulic drives and lubricating systems are indispensable in machine construction, raw material production, navigation and many other areas.

Both as a power transfer medium and lubricant oil is heated by friction losses during operation.

Since the viscosity of the oil changes along with the temperature, precise temperature stabilisation using coolers is a vital requirement for systems and drives for consistent power. In addition to the unlimited supply of ambient air, water is also used as a coolant. The advantage of water is the low susceptibility to seasonal temperature fluctuations and large companies often use it as a central circulation coolant.

BWT plate heat exchangers are a particularly efficient solution in these cases. They're extremely compact, practically maintenance-free and easy to install.

Equally distributed turbulent flow

High exchange efficiency

Low water consumption

Small installation space

High pressure resistance

Maintenance free

Broad temperature range

Easy installation



1800-OILSOL
1800-645765

<https://oilsolutions.com.au/>

sales@oilsolutions.com.au



Introduction and description

Why coolers?

There are basically two main concepts in the development of fluid power systems.

One is to design systems without using a cooler, and if operational conditions show that the system needs a cooler, install it later at additional costs. This understandably then often calls for compromises, making the system more expensive.

The other concept recognizes that a system originally designed with an integrated cooler needs less installation space and is a better choice with respect to construction and system costs.

Why Bühler?

Using an oil/water cooler nowadays requires paying great attention to low water consumption. The tube bundle heat exchangers Bühler had been selling for decades could not meet this requirements, resulting in our search for a new exchanger concept for hydraulics.

Soldered plate heat exchangers meet these requirements outstandingly and further offer other advantages such as requiring little installation space and the high pressure resistance.

Together with a well-known manufacturer, Bühler implemented these findings in a comprehensive product line customised for the requirements in fluid control.

If our standard range of products does not include the right solution for your application, we will gladly develop a custom solution for you.

Use the data in this leaflet to determine a suitable cooler for your application. However, we do recommend using our calculator to configure your cooler. This will allow you to optimise it whilst incorporating various parameters.

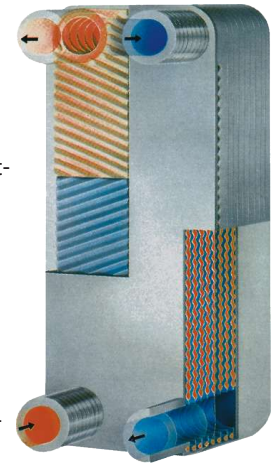

Construction and application

BWT plate heat exchangers are made from patterned stainless steel plates. The direction of the pattern varies from plate to plate, yielding a large number of contacts on the back of the pattern. When the plates are soldered the contacts also connect, forming an extremely compact, pressure-resistant set of plates. And yet virtually the entire material are available for heat exchange.

Function

Compared to other systems the interior geometry of the BWT ensures a turbulent flow, yielding high heat transfer coefficients when using the limits for low flow rates, thus flow speeds, in the configuration. This excludes Zones with a low speed, maintaining an extremely equally distributed flow across the entire exchanger surface. The materials used result in dense, smooth exchanger plate surfaces, significantly reducing the risk of possible corrosion.

These design features of the BWT plate heat exchangers virtually eliminate the risk of deposits within the exchanger.

Planning information

Set-up

The coolers should be installed providing easy accessible and visibility. Any installation position is permitted and may be adapted to the installation conditions. However, the cooler should not be installed on its back.

Secure the plate heat exchanger with the bracket sold as an accessory. The connection lines must be installed free from tension and vibration. We recommend installing tubes or compensators.

Prevent freezing when installed outdoors.

Flow

Oil and water flow in opposite directions inside the heat exchanger (oil inlet F1 → F3, water inlet F4 → F2). The connections can alternatively be switched (oil inlet F3 → F1, water inlet F2 → F4).



1800-OILSOL
1800-645765

<https://oilsolutions.com.au/>

sales@oilsolutions.com.au

Cooling capacity comparison for the various BWT lines

Cooling performance in kW

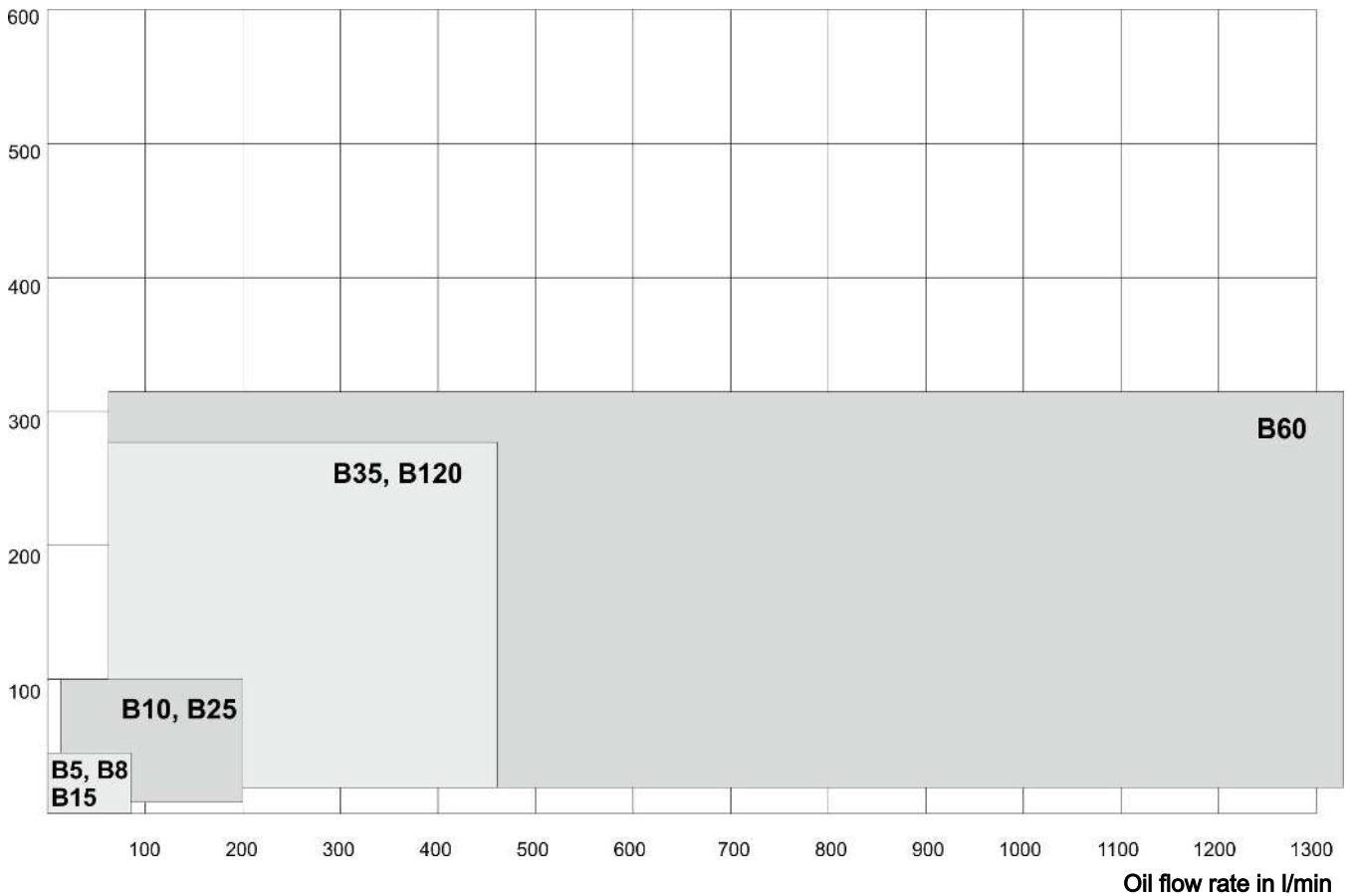

The diagram above shows the applications of the various base types.

Approvals

BWT plate coolers are approved by the following authorities:

Sweden	Statens Anläggningsprovning (SA)
Norway	Kjelkontrollen
Canada	Canadian Standard Association (CSA)
Germany	Technischer Überwachungsverein (TÜV)
USA	Underwriters Laboratories (UL)
Finland	Teknillinen Tarkastuskeskus (TK)
Switzerland	Schweizerischer Verein des Gas- und Wasserfaches (SVGW)
EU	TRB801 No. 25

Bühler is ISO 9001 certified

Technical data BWT

Technical Data

Material	Stainless steel 1.4401, Cu 99.9% and Cu-free soldering material. Also Cu-free soldering materials as special versions BWT-N B5-B28, see data sheet 340005. Flange B60 and up, in Swedish standard SS 2172, DIN 17175.
Operating pressure	
static:	max. 30 bar
dynamic:	20 bar at 5M load cycle, 3 Hz
Operating oil temperature	max. +185 °C



1800-OILSOL
1800-645765

<https://oilsolutions.com.au/>

sales@oilsolutions.com.au

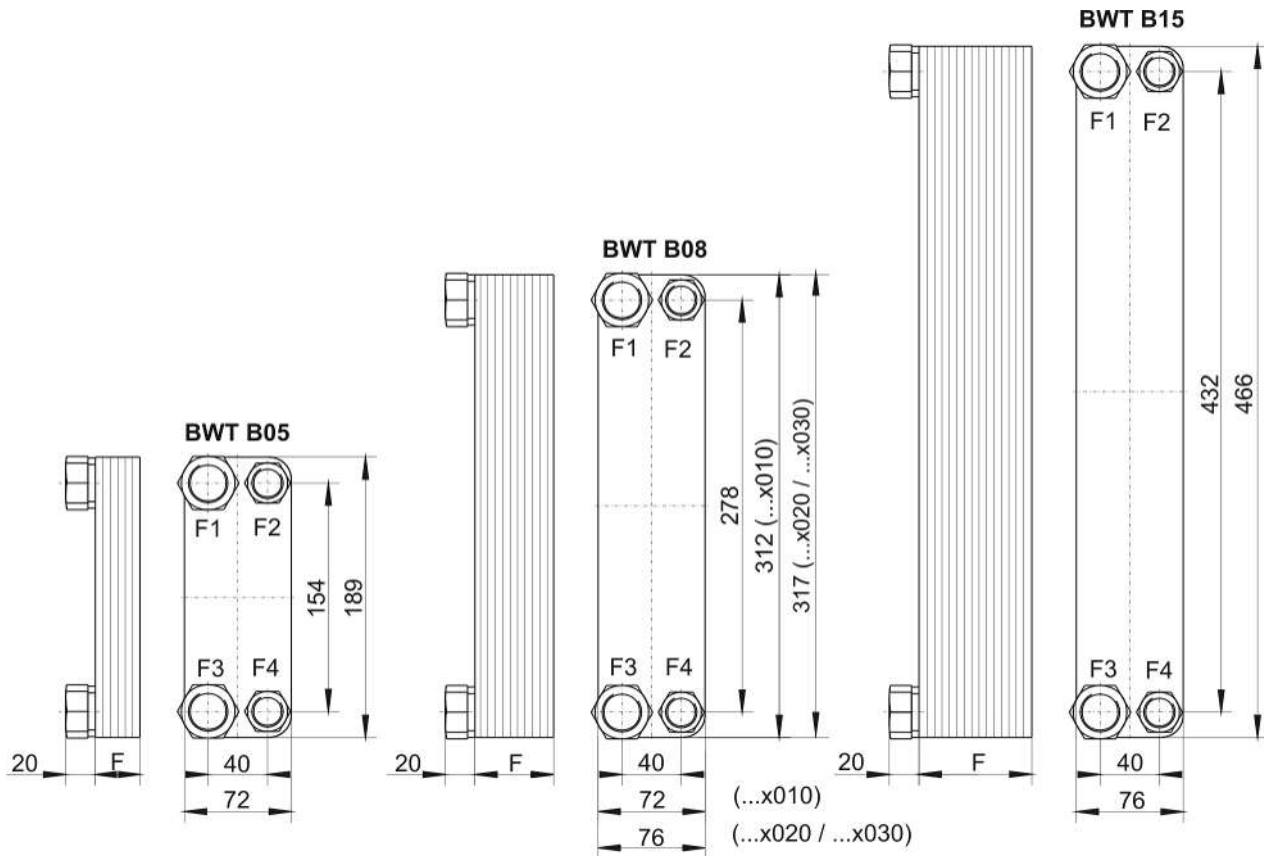

Type	Item no.	F (mm)	Cooling capacity (kW)	Oil connection F3, F1	Water connection F2, F4	Weight (kg – net)	Volume (Litre)
BWT B05x010	3405010	30	1.5 - 5.0	G ¾ 36 mm	G ½ 27 mm	1.0	0.1
BWT B05x020	3405020	53	1.5 - 11	G ¾ 36 mm	G ½ 27 mm	1.5	0.2
BWT B08x010	3408010	30	2.5 - 6.0	G ¾ 36 mm	G ½ 27 mm	1.6	0.5
BWT B08x020	34080200	53	5.0 - 16	G ¾ 36 mm	G ½ 27 mm	2.0	1.0
BWT B08x030	34080300	76	10 - 25	G ¾ 36 mm	G ½ 27 mm	3.0	1.5
BWT B15x030	3415030	76	6.0 - 30	G ¾ 36 mm	G ½ 27 mm	4.0	2.0

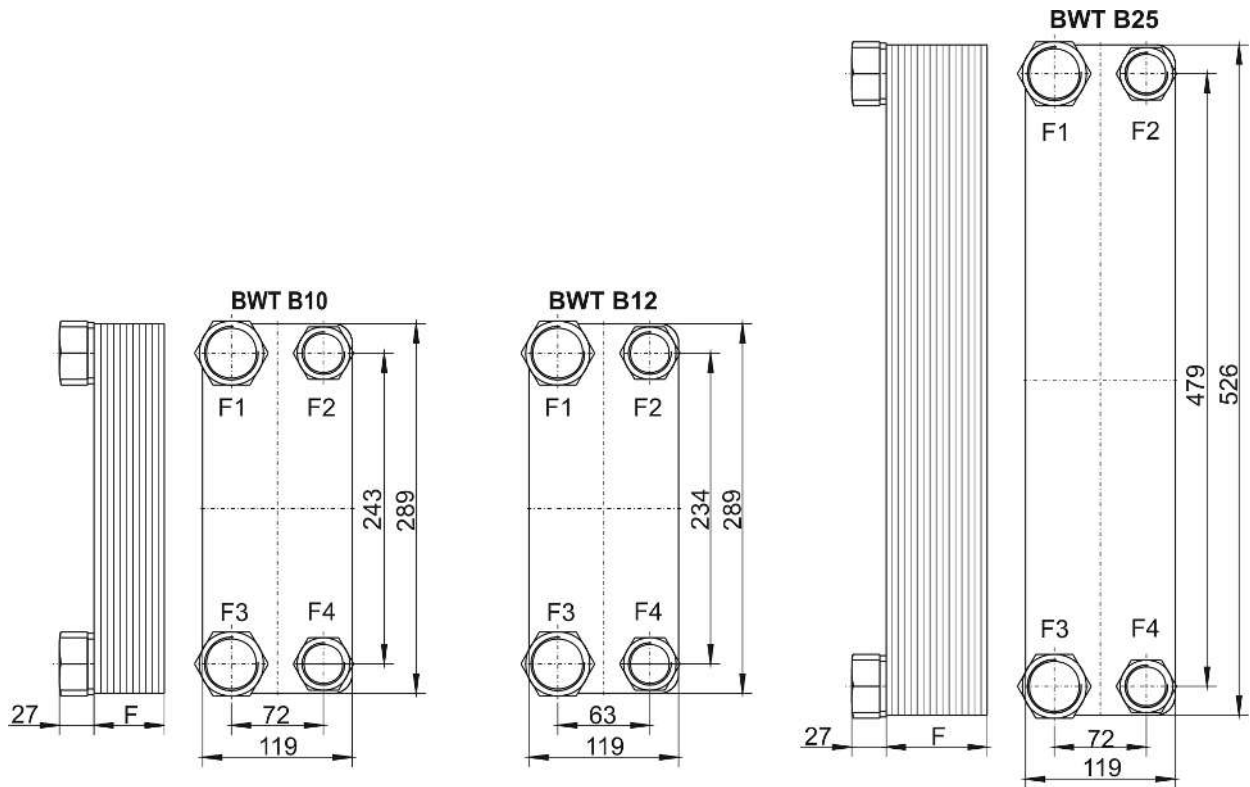

Type	Item no.	F (mm)	Cooling capacity (kW)	Oil connection F3, F1	Water connection F2, F4	Weight (kg – net)	Volume (Litre)
BWT B10x020	3410020	49	5 – 25	G 1 41 mm	G 3/4 36 mm	4.0	1.0
BWT B10x030	3410030	72	10 - 40	G 1 41 mm	G 3/4 36 mm	5.0	1.5
BWT B10x040	3410040	94	10 - 50	G 1 41 mm	G 3/4 36 mm	7.0	2.0
BWT B10x050	3410050	116	15 - 60	G 1 1/4 50 mm	G 1 41 mm	8.0	3.0
BWT B10x070	3410070	161	20 - 65	G 1 1/4 50 mm	G 1 41 mm	10.0	3.5
BWT B10x090	3410090	206	20 - 80	G 1 1/4 50 mm	G 1 41 mm	13.0	4.0
BWT B12Hx060	3412060	145	35 - 85	G 1 1/4 50 mm	G 1 41 mm	13.5	4.3
BWT B25x030	3425030	72	13 - 45	G 1 1/4 50 mm	G 1 41 mm	10.0	2.0
BWT B25x040	3425040	94	13 - 65	G 1 1/4 50 mm	G 1 41 mm	12.0	3.0
BWT B25x060	3425060	139	20 - 90	G 1 1/4 50 mm	G 1 41 mm	17.0	5.0
BWT B25x080	3425080	184	25 - 105	G 1 1/4 50 mm	G 1 41 mm	21.0	7.0



1800-OILSOL
1800-645765

<https://oilsolutions.com.au/>

sales@oilsolutions.com.au

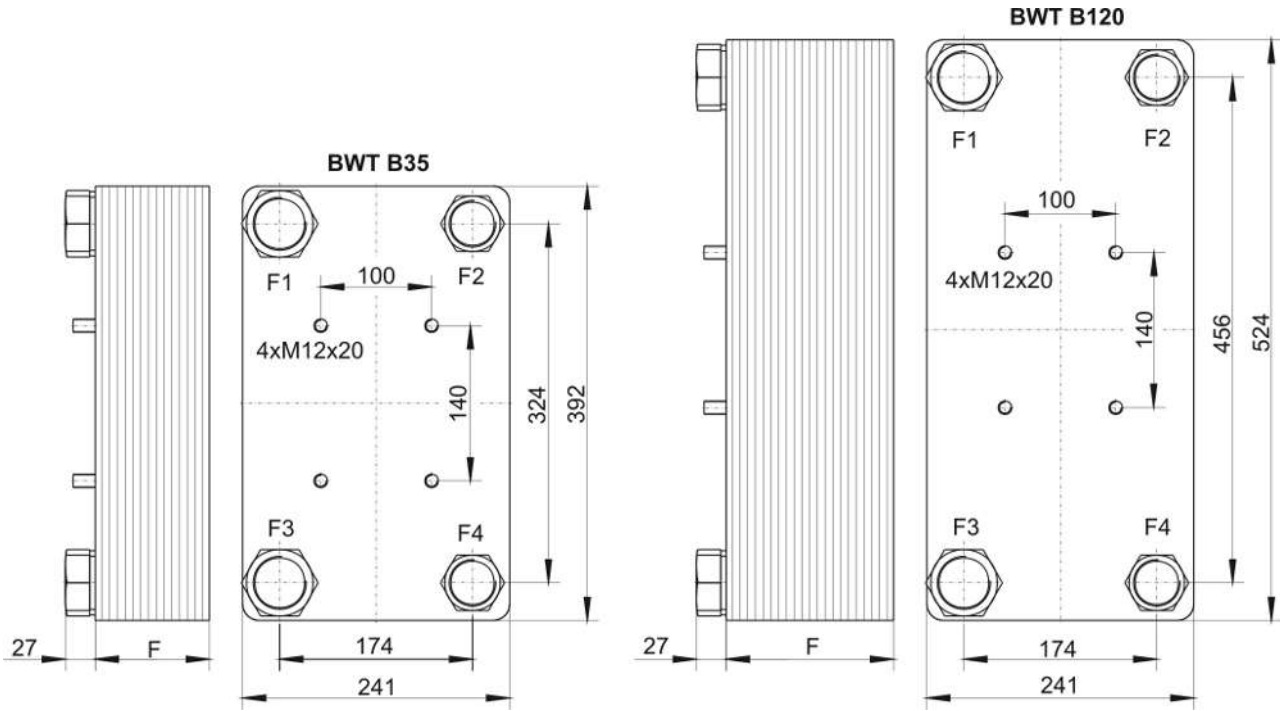

Type	Item no.	F (mm)	Cooling capacity (kW)	Oil connection F3, F1	Water connection F2, F4	Weight (kg – net)	Volume (Litre)
BWT B35x040	3435040	103	30-105	G 1½ 60 mm	G 1¼ 50 mm	18.0	5.0
BWT B35x050	3435050	127	55-145	G 1½ 60 mm	G 1¼ 50 mm	21.0	7.0
BWT B35x060	3435060	151	55-155	G 1½ 60 mm	G 1¼ 50 mm	24.0	8.0
BWT B35x090	3435090	223	55-175	G 1½ 60 mm	G 1¼ 50 mm	34.0	12.0
BWT B120x040	3445040	103	40-125	G 1½ 60 mm	G 1¼ 50 mm	23.0	6.0
BWT B120x060	3445060	151	55-190	G 1½ 60 mm	G 1¼ 50 mm	31.0	10.0
BWT B120x080	3445080	199	65-245	G 1½ 60 mm	G 1¼ 50 mm	40.0	14.0
BWT B120x120	3445120	295	135-280	G 1½ 60 mm	G 1¼ 50 mm	57.0	21.0

B60

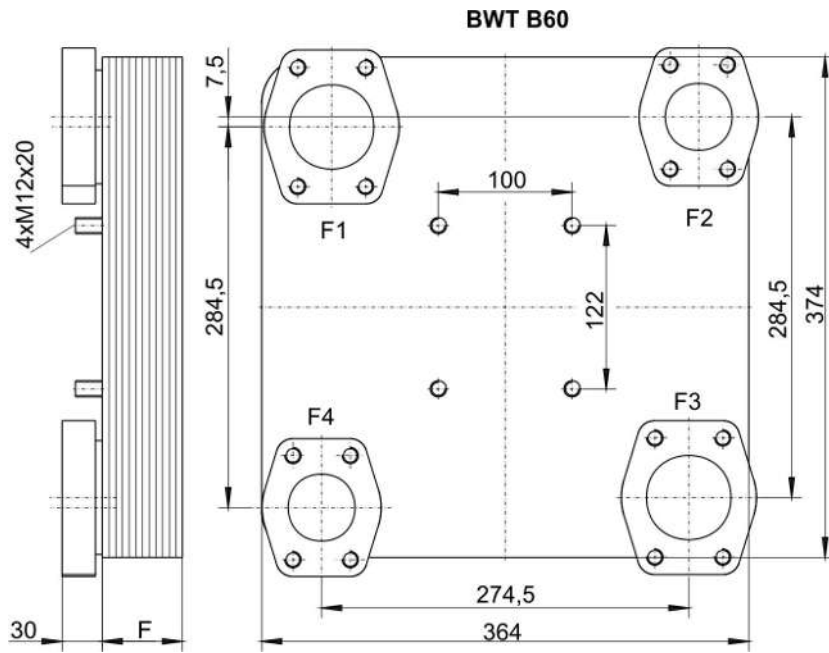

Type	Item no.	F (mm)	Cooling capacity (kW)	Oil connection F3, F1	Water connection F2, F4	Weight (kg – net)	Volume (Litre)
BWT B60x040	3460040	104	30 - 113	SAE 2 1/2 *	SAE 2	33	9
BWT B60x060	3460060	147	35 - 165	SAE 2 1/2 *	SAE 2	42	13
BWT B60x080	3460080	190	40 - 216	SAE 2 1/2 *	SAE 2	52	17
BWT B60x100	3460100	232	43 - 267	SAE 2 1/2 *	SAE 2	61	22
BWT B60x120	3460120	275	56 - 301	SAE 2 1/2 *	SAE 2	70	26
BWT B60x140	3460140	318	76 - 316	SAE 2 1/2 *	SAE 2	80	31

* SAE connections at pressure range 3000 PSI

Mounting brackets

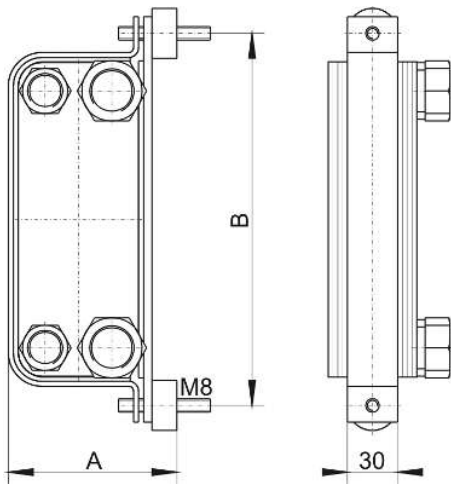

Type	Part no.	A	B	for BWT type
BB05	34BB05	104	223	
BB08	34BB08	104	347	B08 x 010
BB080	34BB080	108	355	B08 x 020 x 030
BB15	34BB15	104	501	
BB10	34BB10	151	323	
BB25	34BB25	151	561	
BB35	34BB35	273	426	
BB 45	34BB45	273	558	

NOTICE! We recommend using two brackets for the types B35-090 and B120-060 up to B120-120.



1800-OILSOL
1800-645765

<https://oilsolutions.com.au/>

sales@oilsolutions.com.au