



Off-line cooler BNK

Drives and hydraulic aggregates are used in machine construction, raw material production, maritime and many other areas.

In hydraulic systems oil transfers power and motion, in drives it's a vital lubricant. Both as a power transfer medium and lubricant oil is heated by friction losses during operation.

Since the viscosity of the oil changes along with the temperature, precise temperature stabilisation using oil/air coolers is a vital requirement for systems and drives for consistent power. The temperature further affects the ageing behaviour and the life of oils.

To minimise the negative fluctuating oil flow has on the cooler design with varying ambient air temperatures, it's wise to combine the cooler with a built-in circulation pump.

The BNK series is characterised by efficient cooling matrixes, a compact, easy to maintain design and energy-efficient drive motors along with gerotor pumps.

Easy to maintain design

Compact installation dimensions

System-compatible cooling matrix/flow rate ratio

Low noise emission

Rugged cooling matrix

Extensive accessories

High suction pump



OIL SOLUTIONS

PO Box 38
Strathfieldsaye, VIC, 3551
1800 OIL SOL
1800 645 765

sales@oilsolutions.com.au

www.oilsolutions.com.au

"For All Your Hydraulic Needs"



Introduction and description

Why coolers?

In many cases, installing an off-line cooler is not only an emergency solution, but also the best solution with respect to mechanics and economics. Oftentimes off-line filtration can also be incorporated quite effectively.

Since a bypass also always requires installation of a separate circulation pump, it's reasonable to combine it with the motor already installed for the fan.

The BNK series is a tiered line of oil/air coolers with circulation pump directly flange-mounted. The cooler size and pump flow rate are coordinated for performance grades compatible with the system. The gerotor pump ensures low noise emission for the entire aggregate.

Why Bühler?

When we developed the BNK series, we incorporated our years of experience in designing and selling oil/air coolers. Especially the fatigue life of the cooling matrix was a focus during development.

The cooling matrix can easily be removed from the fan case for maintenance without uninstalling the fan or motor.

If our comprehensive standard range of products does not include the right solution for your application, we will gladly develop a custom solution for you.

Use the data in this leaflet to determine a suitable cooler for your application.

Construction and application

The BNK consists of the following components:

- Cooling matrix
- Fan case with mounting rails
- Blower and pump unit consisting of AC motor, pump, fan, protective/mounting grate and motor bracket

The cooling matrix and fan/pump unit can be removed from the fan case individually without having to uninstall other components

The BNK series cooling matrix are made from aluminum. The coolers are designed for use in hydraulic circuits.

We also offer cooling matrix bypass versions (see type code).

Planning information

Set-up

The cooler must be set up so as not to interfere with air supply and exhaust. The distance to air obstacles behind the cooler should be at least half the cooler height (Dimension B).

Ensure adequate ventilation. During set-up, avoid exiting hot air or noise emission causing problems.

If the ambient air is dirty, excess deposit on the cooling matrix must be expected. This will reduce the cooling capacity. In this case, particularly in the case of air loaded with oil mist, the air ducts must be cleaned regularly.

When set up outdoors, adequately protect the motor from the weather.

Ensure easy access for inspection and maintenance.

Mount

The coolers are secured to the mounting rails with four screws. Be sure the support structure is sized adequately. Install in any position.

Connecting the oil circuit

The connection between the system and the cooling matrix should be connected stress and vibration free, which can be achieved by using conduit.

Follow the pertinent safety regulations to prevent environmental damage due to possible oil leaks (e.g. collection pans).



1800-OILSOL
1800-645765

<https://oilsolutions.com.au/>

sales@oilsolutions.com.au

Technical data

Technical Data

Materials/surface protection

Cooling matrix:	Aluminium, painted
ventilation box, safety guard and motor brackets:	Steel, powder-coated
Pump:	anodised aluminium, sintered steel

Colour: RAL 7001

Operating fluids: Mineral oils per DIN 51524
Gear oil per DIN 51517-3

Operating pressure, static: 8/16/29/42 L/min – max. 6 bar
58/88 L/min – max. 8 bar

Suction pressure: max. - 0.4 bar

Operating oil temperature: max. 80 °C (higher upon request)

max. viscosity: 100 cSt medium viscosity (higher upon request)

Ambient temperature: -15 to +40 °C

Electric motors (others available upon request)

Voltage / frequency: 220/380V – 230/400V – 240/415V 50Hz
460 60 Hz

Thermal stability: Insulation class F,
utilisation per Class B

Protection class: IP55

The motors comply with standards
IEC 60034, IEC 60072, IEC 60085

Calculation example and nomenclature

t_{OE} [°C]	Inlet oil temperature
t_{LE} [°C]	Inlet air temperature
ETD [K]	Temperature differential: $ETD = t_{OE} - t_{LE}$
P_{spez} [kW / K]	specific cooling performance (see performance curves): $P_{spez} = P / ETD$
P [kW]	Cooling performance in kW
Q [l/min]	Oil flow rate
C_{oil} [kJ/kgK]	Specific heat capacity of the oil (approx. 2.0 kJ / kgK)
ζ [kg/dm ³]	Gravity of oil ≈ 0.9 kg/dm ³

Calculation example

Assumptions:

Tank capacity (V) approx. 200 L

Start up temperature of oil (T_1) 15 °C (≈ 288 K)

Oil heats up in approx.

$t = 25$ min. (1500 s) to (T_2) 45 °C (≈ 318 K)

Required oil temperature (t_{OE}) 60 °C

Inlet air temperature (t_{LE}) 30 °C

Calculation:

- Calculating P from the tank warming

$$P = \frac{V \cdot \zeta \cdot c_{oil} (T_2 - T_1)}{t} = \frac{200 \text{ l} \cdot 0.9 \frac{\text{kg}}{\text{l}} \cdot 2 \frac{\text{kJ}}{\text{kg} \cdot \text{K}} \cdot (318 \text{ K} - 288 \text{ K})}{1500 \text{ s}} = 7.2 \text{ kW}$$

- ETD = $t_{OE} - t_{LE} = 60 \text{ °C} - 30 \text{ °C} = 30 \text{ K}$

- Determining the cooler size: $P_{spez} = P / ETD = 7.2 \text{ kW} / 30 \text{ K} = 0.24 \text{ kW/K}$

- Select a cooler from the basic data with $P_{spez} 0.24 \text{ kW/K}$. There is one option:
BNK 3.4 with 30 L pump



1800-OILSOL
1800-645765

<https://oilsolutions.com.au/>

sales@oilsolutions.com.au

Basic data (at 50 Hz frequency)

Item no.	Cooler model	spec. cooling capacity kW/K	Cooling capacity at ETD = 40 K (kW)	max. circulation rate (L/min)	Motor power Number of motor contacts Rated current at 400 V	Weight (kg)	Volume (L)	Noise db(A)*
3601406IE3**	BNK 1.4-7,5-0,75kW	0,04	1,6	8	0,75 kW/4/1,62 A	30	0,7	64
3601401IE3**	BNK 1.4-15-0,75kW	0,05	2	16	0,75 kW/4/1,62 A	30	0,7	64
3602406IE3**	BNK 2.4-7,5-0,75kW	0,09	3,6	8	0,75 kW/4/1,62 A	37	1,3	66
3602401IE3**	BNK 2.4-15-0,75kW	0,11	4,4	16	0,75 kW/4/1,62 A	39	1,3	66
3602402IE3**	BNK 2.4-30-0,75kW	0,13	5,2	29	0,75 kW/4/1,62 A	40	1,3	66
3602407IE3**	BNK 2.4-40-1,1kW	0,14	5,6	42	1,1 kW/4/2,35 A	43	1,3	66
3603406IE3**	BNK 3.4-8-0,75kW	0,17	6,8	8	0,75 kW/4/1,62 A	46	1,8	71
3603401IE3**	BNK 3.4-15-0,75kW	0,20	8	16	0,75 kW/4/1,62 A	45	1,8	71
3603402IE3**	BNK 3.4-30-0,75kW	0,23	9,2	29	0,75 kW/4/1,62 A	45	1,8	71
3603407IE3**	BNK 3.4-40-1,1kW	0,25	10	42	1,1 kW/4/2,35 A	48	1,8	71
3604401IE3**	BNK 4.4-15-0,75kW	0,24	9,6	16	0,75 kW/4/1,62 A	53	2,3	73
3604402IE3**	BNK 4.4-30-0,75kW	0,30	12	29	0,75 kW/4/1,62 A	50	2,3	73
3604407IE3**	BNK 4.4-40-1,1kW	0,33	13,2	42	1,1 kW/4/2,35 A	54	2,3	73
3604403IE3**	BNK 4.4-60-1,5kW	0,35	14	58	1,5 kW/4/3,17 A	59	2,3	73
3604404IE3**	BNK 4.4-90-2,2kW	0,37	14,8	88	2,2 kW/4/4,56 A	74	2,3	73
3605403IE3**	BNK 5.4-60-2,2kW	0,55	22	58	2,2 kW/4/4,56 A	80	3,1	79
3605404IE3**	BNK 5.4-90-2,2kW	0,60	24	88	2,2 kW/4/4,56 A	81	3,1	79
3606413IE3**	BNK 6.4-60-3,0kW	0,90	36	58	3,0 kW/4/6,15 A	100	4,1	86
3606414IE3**	BNK 6.4-90-3,0kW	1,01	40,4	88	3,0 kW/4/6,15 A	101	4,1	86
3606613IE3***	BNK 6.6-60-2,2kW	0,65	26	58	2,2 kW/6/4,7 A	88	4,1	74
3607413IE3**	BNK 7.4-60-3,0kW	0,93	37,2	58	3,0 kW/4/6,15 A	110	5,4	89
3607414IE3**	BNK 7.4-90-3,0kW	1,04	41,6	88	3,0 kW/4/6,15 A	111	5,4	89
3607613IE3***	BNK 7.6-60-2,2kW	0,71	28,4	58	2,2 kW/6/4,7 A	98	5,4	75
3608613IE3**	BNK 8.6-60-3,0kW	1,10	44	58	3,0 kW/6/6,91 A	162	6,3	79

*DIN EN ISO 3744, Class 3

**Electr. motor per NEMA, UL, CSA, EAC approval

***Electr. motor per NEMA, UL, CUL approval

Model key

BNK 4.4-30-0.75kW- IBx

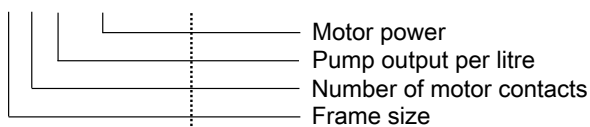

To also have a bypass, the specification will be added to the type designation:

BNK 4.4-30-0.75kW- IBx

Bypass version	AB	(BNK 2-8)	external bypass
	IB	(BNK 3-8)	internal bypass
	ITB	(BNK 3-8)	internal temperature-dependent bypass 2 bar / 45 °C
	ATB	(BNK 2-8)	external temperature-dependent bypass 2 bar / 45 °C
	x		bypass value 2 bar, 5 bar, 8 bar



1800-OILSOL
1800-645765

<https://oilsolutions.com.au/>

sales@oilsolutions.com.au

Dimensions

BNK 1

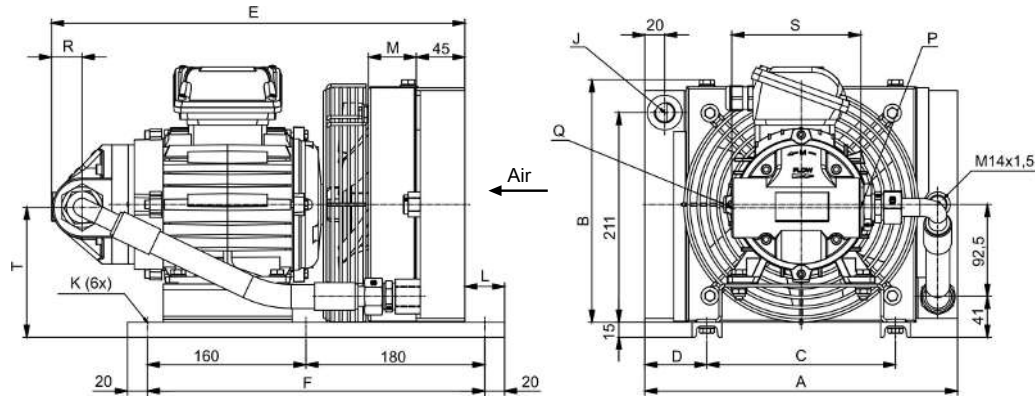

BNK 2-8

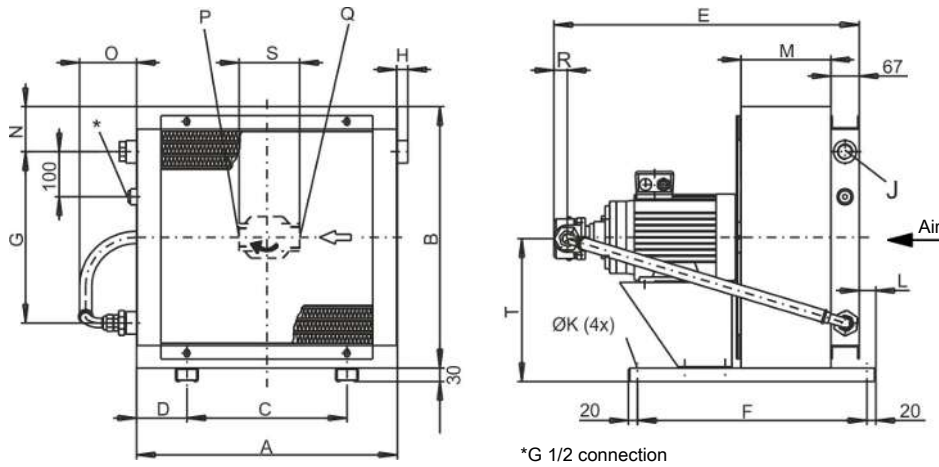

Model	A	B	C	D	E	F	G	H	J	K	L	M	N	O	P	Q	R	S	T
BNK 1.4-7,5-0,75kW	315	243	190	62,5	417	340	-	-	2x G 1/2	9	40	52	-	-	G1	G3/4	30	144	130
BNK 1.4-15-0,75kW	315	243	190	62,5	417	340	-	-	2x G 1/2	9	40	52	-	-	G1	G1 1/4	30	130	130
BNK 2.4-7,5-0,75kW	370	370	203	83,5	476	510	-	25	2x G1	9	33	125	106	119	G1	G3/4	30	130	212
BNK 2.4-15-0,75kW	370	370	203	83,5	476	510	-	25	2x G1	9	33	125	106	119	G1	G1 1/4	30	130	212
BNK 2.4-30-0,75kW	370	370	203	83,5	474	510	-	25	2x G1	9	33	125	106	119	G1	G1 1/4	30	130	212
BNK 2.4-40-1,1kW	370	370	203	83,5	494	510	-	25	2x G1	9	33	125	106	119	G1	G1 1/4	30	130	212
BNK 3.4-8-0,75kW	440	440	203	118,5	501	510	230	25	3x G1	9	33	150	105	119	G1	G3/4	30	130	247
BNK 3.4-15-0,75kW	440	440	203	118,5	501	510	230	25	3x G1	9	33	150	105	119	G1	G1 1/4	30	130	247
BNK 3.4-30-0,75kW	440	440	203	118,5	499	510	230	25	3x G1	9	33	150	105	119	G1	G1 1/4	30	130	247
BNK 3.4-40-1,1kW	440	440	203	118,5	520	510	230	25	3x G1	9	33	150	105	119	G1	G1 1/4	30	130	247
BNK 4.4-15-0,75kW	500	500	203	148,5	526	510	230	25	3x G1	9	33	175	104	119	G1	G1 1/4	30	130	277
BNK 4.4-30-0,75kW	500	500	203	148,5	524	510	230	25	3x G1	9	33	175	104	119	G1	G1 1/4	30	130	277
BNK 4.4-40-1,1kW	500	500	203	148,5	546	510	230	25	3x G1	9	33	175	104	119	G1	G1 1/4	30	130	277
BNK 4.4-60-1,5kW	500	500	203	148,5	610	510	230	25	3x G1	9	33	175	104	131	G1 1/4	G1 1/2	30	135	277
BNK 4.4-90-2,2kW	500	500	203	148,5	688	510	230	25	3x G1	9	33	175	104	131	G1 1/4	G1 1/2	53	135	277
BNK 5.4-60-2,2kW	580	580	356	112	678	510	305	23,5	3x G1	9	33	200	100	131	G1 1/4	G1 1/2	30	135	317
BNK 5.4-90-2,2kW	580	580	356	112	713	510	305	23,5	3x G1	9	33	200	100	131	G1 1/4	G1 1/2	53	135	319
BNK 6.4-60-3,0kW	700	700	356	172	737	510	410	9,5	3x G1 1/4	9	33	225	110	132	G1 1/4	G1 1/2	30	135	377
BNK 6.4-90-3,0kW	700	700	356	172	772	510	410	9,5	3x G1 1/4	9	33	225	110	132	G1 1/4	G1 1/2	53	135	377
BNK 6.6-60-2,2kW	700	700	356	172	751	510	410	9,5	3x G1 1/4	9	33	225	110	132	G1 1/4	G1 1/2	53	135	377
BNK 7.4-60-3,0kW	700	840	356	172	762	510	590	9,5	3x G1 1/4	9	33	250	91	132	G1 1/4	G1 1/2	30	135	447
BNK 7.4-90-3,0kW	700	840	356	172	797	510	590	9,5	3x G1 1/4	9	33	250	91	132	G1 1/4	G1 1/2	53	135	447
BNK 7.6-60-2,2kW	700	840	356	172	776	510	590	9,5	3x G1 1/4	9	33	250	91	132	G1 1/4	G1 1/2	53	135	447
BNK 8.6-60-3,0kW	870	870	508	181	854	665	585	11	3x G1 1/4	9	33	275	101,5	133	G1 1/4	G1 1/2	53	135	462

Functional diagram

Standard version BNK 2

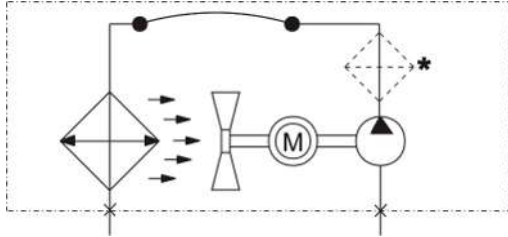

* recommended position of additional oil filter

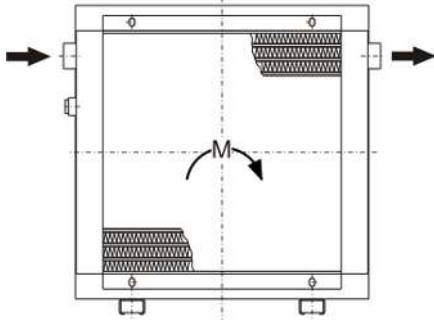

The oil inlet is on the left of the cooling battery. The oil outlet is always on the opposite side.

Standard version BNK 1, 3 to BNK 8

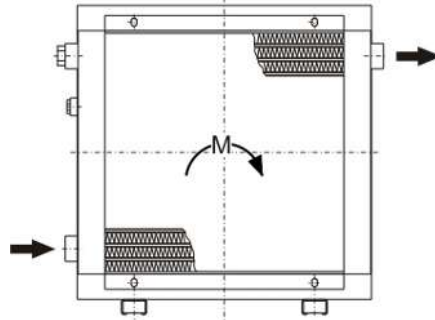
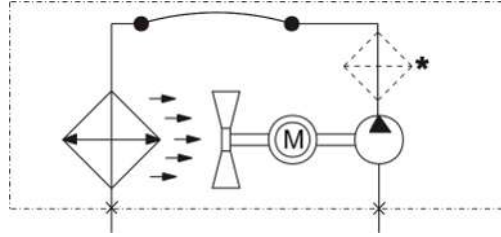

The oil inlet is on the bottom left of the cooling battery. The second connection at the top must be closed. The oil outlet is always on the opposite side.

Internal bypass IB/ ITB (BNK 3-8)

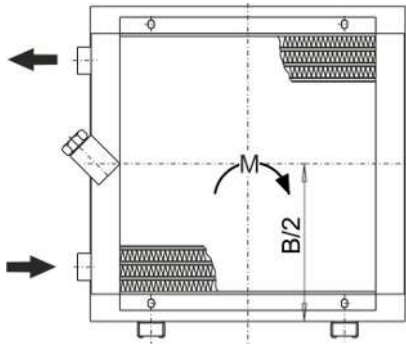

The oil inlet and outlet is always on the same side of the cooling battery. The connection on the opposite side must be closed.

External bypass AB/ATB (BNK 2-8)

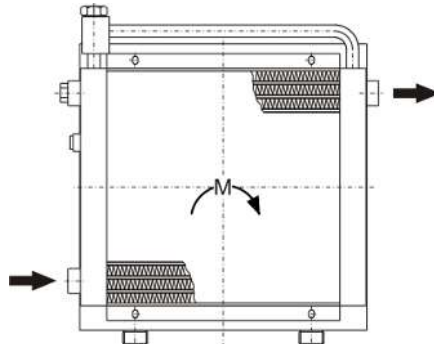

The oil inlet is always at the bottom left of the cooling battery. The second connection must be closed. The oil outlet is always on the opposite side.

With bypass valve

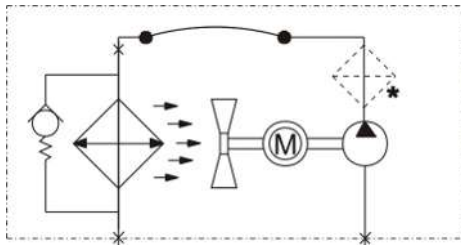

With temperature-dependent bypass valve

