

# PWO

## TECHNICAL DATA

The curves are based on  
 Oil  
 Oil inlet temperature  
 Water inlet temperature  
 Oil/Water Ratio

ISO VG68  
 60°C  
 20°C  
 2:1

**Note:** The diagrams also include non-standard sizes.  
 Please contact OLAER for availability.

### Oil pressure drop - PWO K5

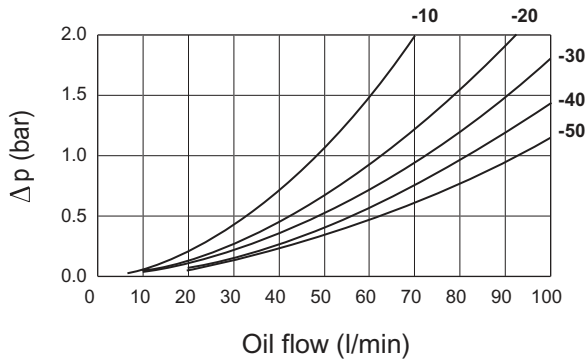

### Oil pressure drop - PWO K10

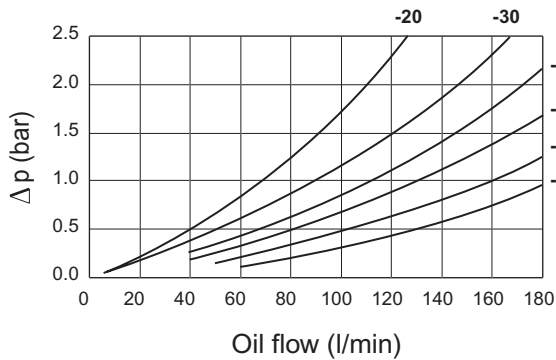

### Heat dissipation - PWO K5

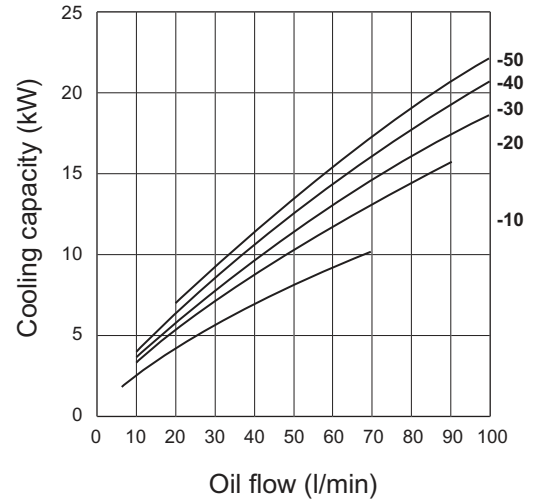

### Heat dissipation - PWO K10

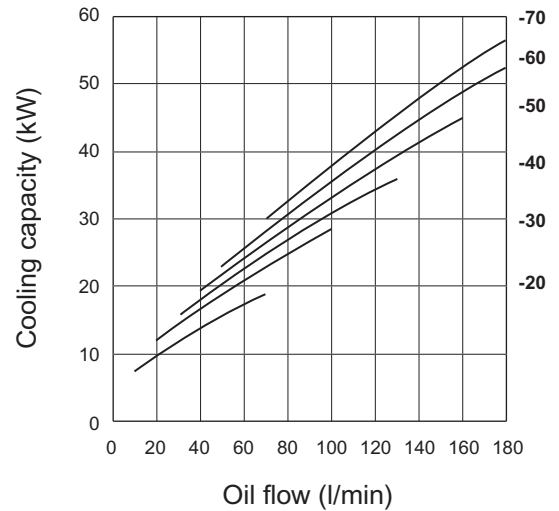

### Correction factor for other oil/water flow ratio

# 36

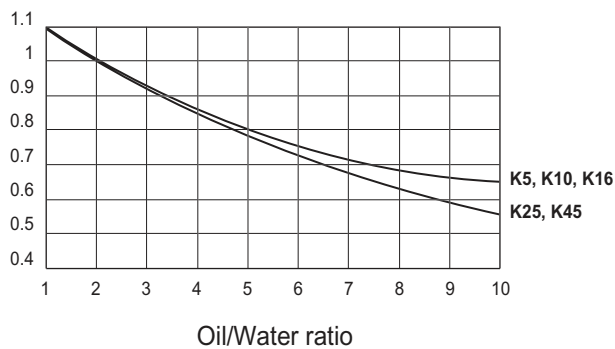



Oil Solutions

PO Box 38  
Strathfieldsaye, VIC, 3551  
1800 OIL SOL  
1800 645 765  
[sales@oilsolutions.com.au](mailto:sales@oilsolutions.com.au)  
[www.oilsolutions.com.au](http://www.oilsolutions.com.au)  
"For All Your Hydraulic Needs"



# PWO

## TECHNICAL DATA

### Heat dissipation - PWO K16

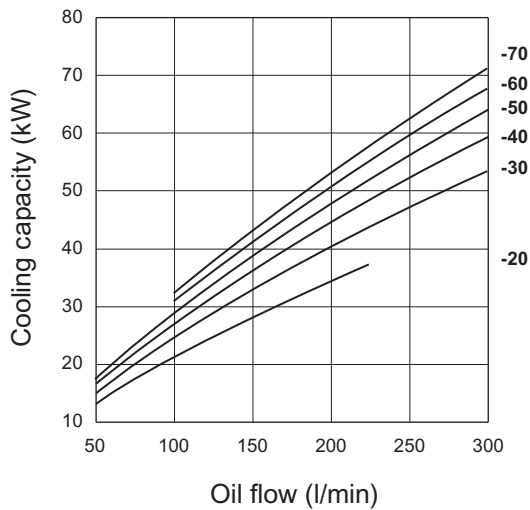

### Heat dissipation - PWO K25

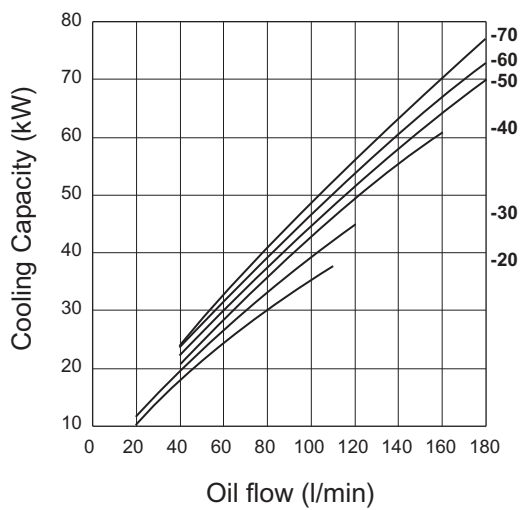

### Heat dissipation - PWO K45

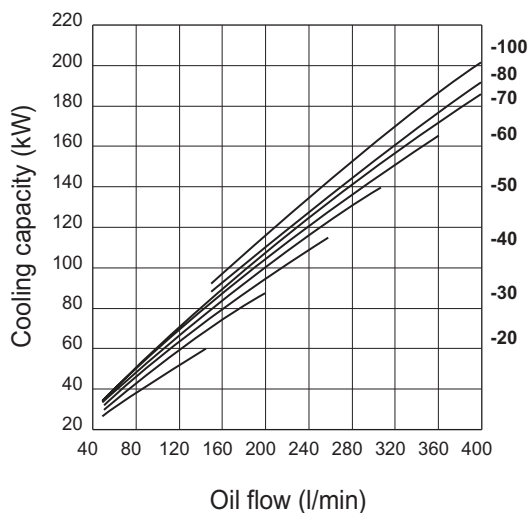

The curves are based on  
 Oil ISO VG68  
 Oil inlet temperature 60°C  
 Water inlet temperature 20°C  
 Oil/Water Ratio 2:1

**Note:** The diagrams also include non-standard sizes. Please contact OLAER for availability.

### Oil pressure drop - PWO K16

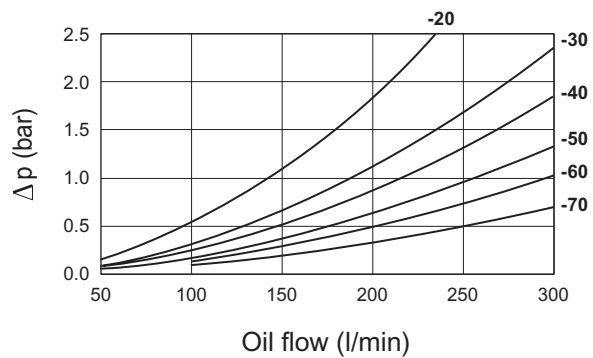

### Oil pressure drop - PWO K25

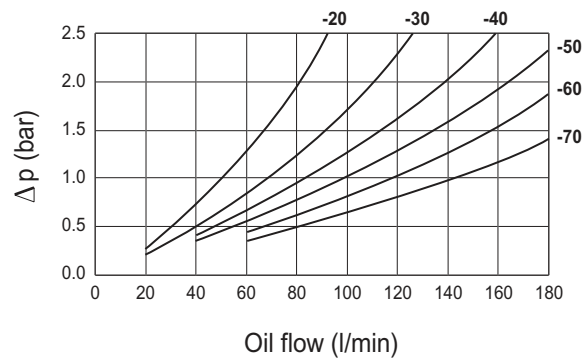

### Oil pressure drop - PWO K45

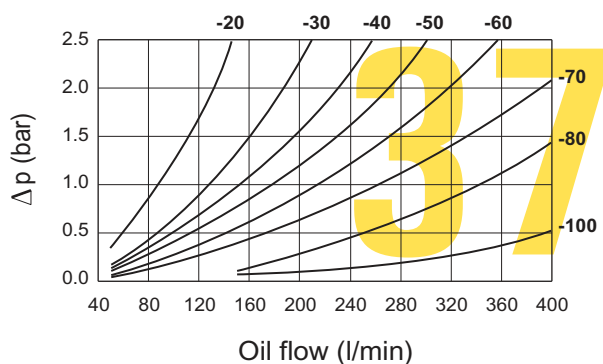

# PWO

## TECHNICAL DATA

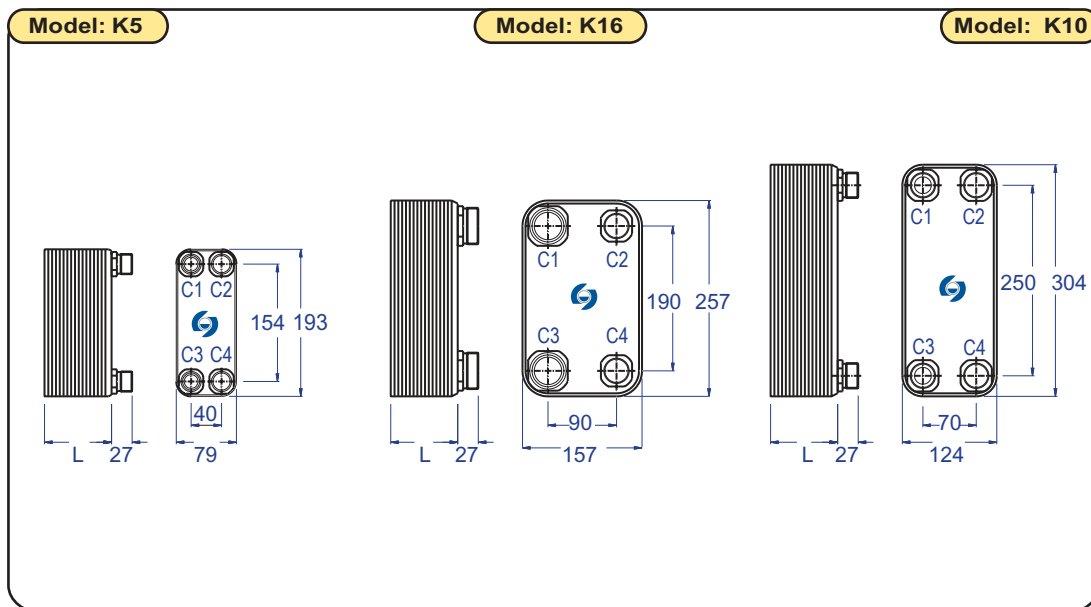

### K5

| Number of plates | Connectors |         | L(mm) | Weight (kg) |
|------------------|------------|---------|-------|-------------|
|                  | C1/C3      | C2/C4   |       |             |
| 10               |            |         | 38    | 1.9         |
| 20               |            |         | 61    | 2.4         |
| 30               | 1" BSPP    | ¾" BSPT | 84    | 2.8         |
| 40               |            |         | 107   | 3.3         |
| 50               |            |         | 130   | 3.8         |

### K10

| Number of plates | Connectors |         | L(mm) | Weight (kg) |
|------------------|------------|---------|-------|-------------|
|                  | C1/C3      | C2/C4   |       |             |
| 20               |            |         | 64    | 6.5         |
| 30               |            |         | 88    | 8           |
| 40               | 1" BSPP    | 1" BSPT | 112   | 9.5         |
| 50               |            |         | 135   | 11          |
| 60               |            |         | 159   | 12.5        |
| 70               |            |         | 182   | 14          |

### K25

| Number of plates | Connectors |         | L(mm) | Weight (kg) |
|------------------|------------|---------|-------|-------------|
|                  | C1/C3      | C2/C4   |       |             |
| 20               |            |         | 64    | 10          |
| 30               |            |         | 88    | 12.5        |
| 40               | 1¼" BSPP   | 1" BSPT | 112   | 15          |
| 50               |            |         | 135   | 17.5        |
| 60               |            |         | 159   | 20          |
| 70               |            |         | 182   | 22.5        |

### K16

| Number of plates | Connectors |         | L(mm) | Weight (kg) |
|------------------|------------|---------|-------|-------------|
|                  | C1/C3      | C2/C4   |       |             |
| 20               |            |         | 76    | 7           |
| 30               |            |         | 104   | 8.5         |
| 40               | 1½" BSPP   | 1" BSPT | 133   | 10          |
| 50               |            |         | 161   | 11.5        |
| 60               |            |         | 190   | 15          |
| 70               |            |         | 218   | 14.5        |

### K45

| Number of plates | Connectors |           | L(mm) | Weight (kg) |
|------------------|------------|-----------|-------|-------------|
|                  | C1/C3      | C2/C4     |       |             |
| 20               |            |           | 65    | 20          |
| 30               |            |           | 89    | 25          |
| 40               |            |           | 112   | 30          |
| 50               | 1 ½" BSPP  | 1 ½" BSPT | 136   | 35          |
| 60               |            |           | 159   | 41          |
| 70               |            |           | 183   | 46          |
| 80               |            |           | 206   | 51          |
| 100              |            |           | 253   | 56          |

# 38

# PWO

## TECHNICAL DATA

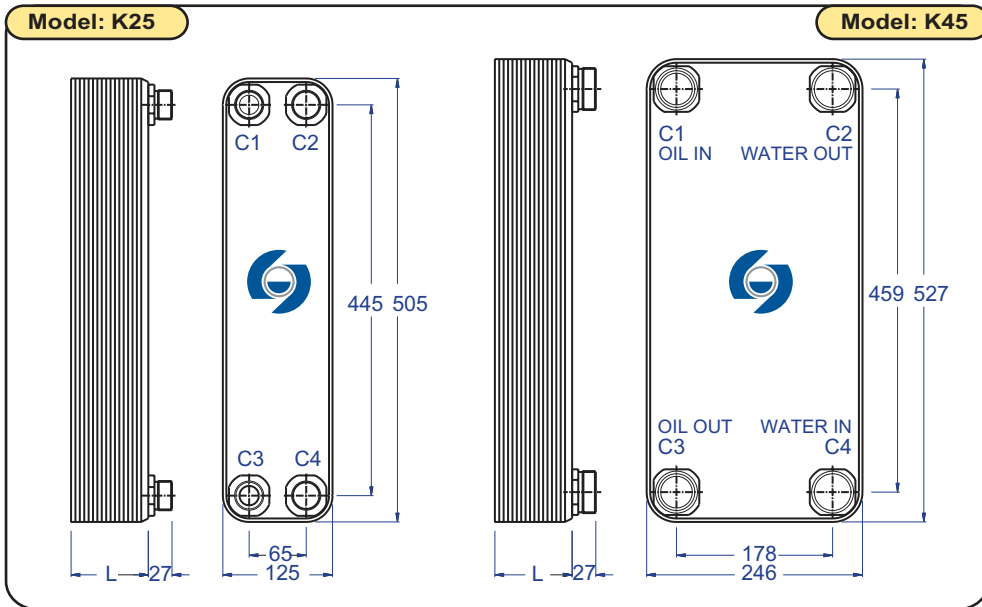

| Size       | A          | B          | C          | N° brackets | N° plates      | N° brackets | N° plates      | N° brackets | N° plates       |
|------------|------------|------------|------------|-------------|----------------|-------------|----------------|-------------|-----------------|
| K5         | 225        | 255        | 90         | 1           | < 50           |             |                |             |                 |
| K10        | 335        | 366        | 135        | 1           | < 40           | 2           | < 70           |             |                 |
| K16        | 289        | 319        | 168        | 1           | < 40           | 2           | < 70           |             |                 |
| K25        | 537        | 567        | 136        | 1           | < 40           | 2           | < 70           |             |                 |
| <b>K45</b> | <b>559</b> | <b>589</b> | <b>257</b> | <b>1</b>    | <b>&lt; 40</b> | <b>2</b>    | <b>&lt; 60</b> | <b>3</b>    | <b>&lt; 100</b> |

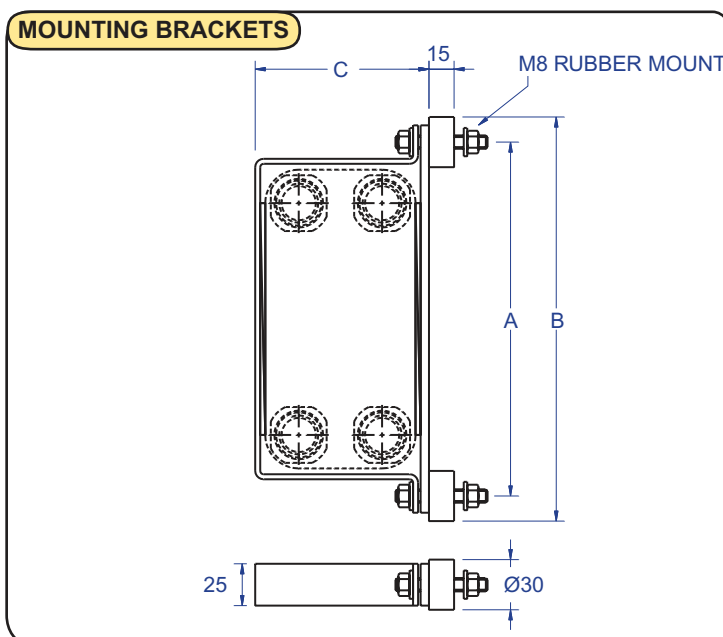

# 39



1800-OILSOL  
1800-645765

<https://oilsolutions.com.au/>

sales@oilsolutions.com.au