

# Efficient automation solutions for plastics and die casting machines





## Your system partner for multi-technology machine concepts

Injection molding, blow molding and die casting machines increase output with reproducible quality and minimal energy consumption using precisely defined motion sequences and tailored process controllers. Take advantage of the entire range of Rexroth products with finely scaled components and systems. We will tailor them perfectly to your machine concept and give you a decisive competitive edge: from multi-technology consulting with substantial application expertise to engineering, to solutions with shorter cycle times and improved energy efficiency.

**We speak your language**

For decades, Rexroth has been working closely with machine manufacturers worldwide to develop application-specific concepts for continuously increasing productivity and efficiency. We have cultivated system partnerships and remain in constant dialog with these partners. Our industry specialists know that your ideal automation solution requires looking at the entire machine, from the controller to the actuator.

**Every technology from a single source**

Rexroth gives you the choice between hydraulic, electric and hybrid drives. Standardized interfaces and shared software tools greatly simplify startup and support your modular machine concepts. Innovative solutions such as variable-speed pump drives or ready-to-install, self-sufficient axes with integrated fluid circuits combine the benefits of hydraulics with those of electricity.

**Greater energy efficiency**

The focus still remains on achieving the highest energy efficiency with maximum productivity. The Rexroth 4EE system allows you to tap into any potential for increasing energy efficiency; consumption reductions of up to 80% are completely realistic. Together we can make your energy-saving machine concepts a reality.

**Simple engineering**

We accompany you throughout the engineering process, reducing your time to market. With simulation programs by Rexroth, we can find the perfectly designed solution that is extremely dynamic and fast. But that's not all. Whether complete solutions for machine functions, saving on components or downsizing for space-saving machines: our controllers, and hydraulic and electric drives streamline engineering with open interfaces and standardized software tools.

**Maximum productivity**

Good repeat accuracy, highly dynamic motions and maximum flexibility in production determine the productivity of plastics and die casting machines. This also includes standardized, state-of-the-art machine reliability, since only reliable machines are efficient.

02	System partner for machine concepts
04	Injection molding machines
06	Blow molding machines
08	Die casting machines
12	The Sytronix family
14	Dynamic, energy-efficient drives
16	Powerful, energy-efficient drives
18	4EE – energy efficiency with system
20	Control technology
22	Single and multi-axis controllers
24	Open Core Engineering: new freedom for custom control concepts
26	Self-contained servo axes
28	Simulation, planning and configurators
30	Components and modules
32	Filtration
33	Basic and advanced training
34	Service
35	Your benefits

# Injection molding machines need the perfect mix

Hydraulic core plus, hybrid clamp, electric ejector: more and more injection molding machine manufacturers are relying on hybrid concepts. They combine hydraulic, electric and hybrid drives to cover a wide range of performance requirements with a single machine family. Rexroth supports this trend.

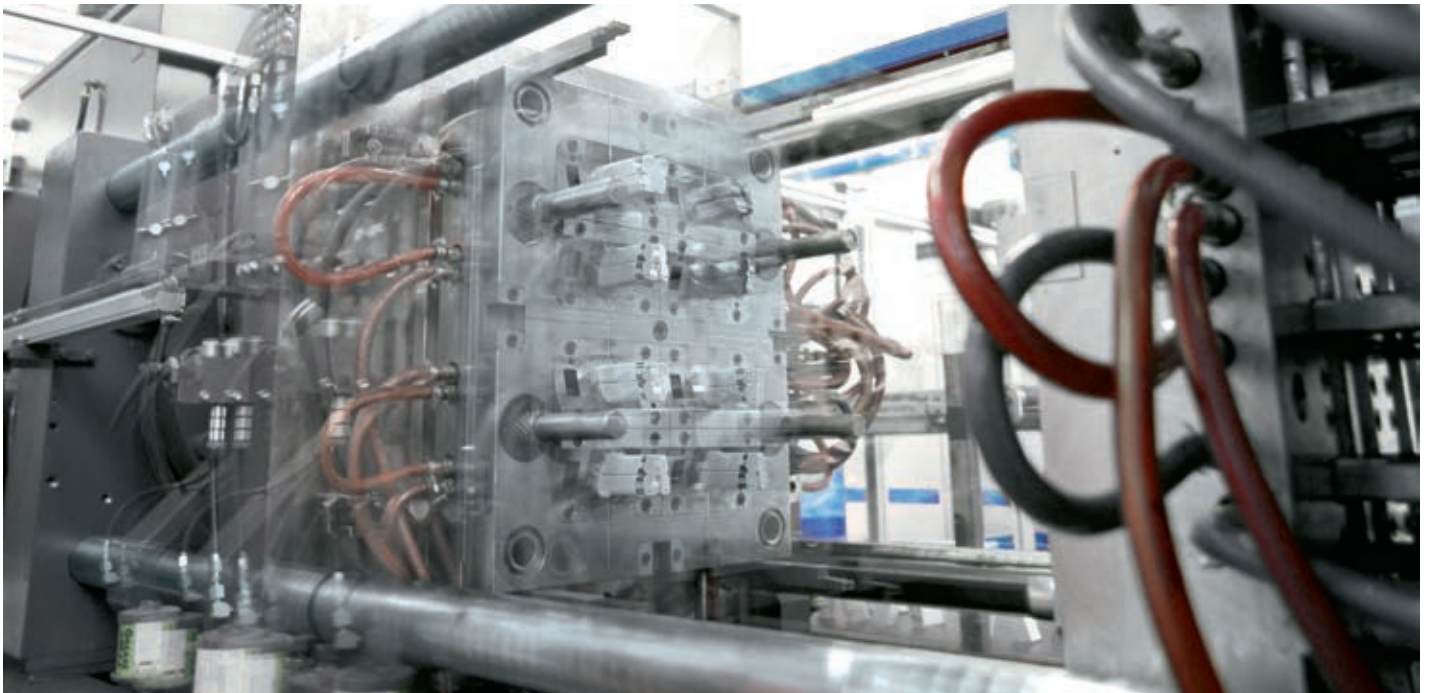

## **Drive and control experience on call**

Implementing complex motion profiles for a specific application: Rexroth specialists use their decades of experience to develop tailored solutions for your injection molding machine.

Years of working with numerous customers in our world-wide application centers has allowed us to gather one-of-a-kind expertise. Based on this expertise, we have already

mapped, tried and tested control functions to preset software functions. Whether hydraulic or electric drives: you will never have to spend time programming them yourself. Our preset controllers usually make parameterization a snap. This allows you to achieve extremely short cycle times and maximum process reliability.

### Standardized engineering tools

The same interfaces and engineering tools for hydraulic and electric drives as well as the controller make developing modular injection molding machine families even easier. With virtually identical programming, you can choose between hydraulic and electric drives for the injection cylinder and the clamp.

Take advantage of the benefits of a partnership with Rexroth: all drives and controllers from a single source with optimized interfaces, tried and tested control functions and minimized installation sizes.

### Energy-efficient technology use

Energy efficiency and noise emissions: these two factors are becoming more and more important to the end users of injection molding machines. Rexroth has significantly advanced the hydraulics to this end in recent years. Our hydraulic solutions with electric drives also produce comparable results both in terms of energy consumption and noise emissions.

You now have more freedom than ever to choose the best and most efficiency type of drive for any drive task and integrate it into your concepts as desired. We can help you with intelligent energy management for all drive technology.

### Reliable machines, maximum productivity

Standardized, state-of-the-art functional reliability always requires looking at the entire system. We help you fulfill these complex requirements efficiently and increase productivity: with greater dynamics and repeat accuracy, with maximum flexibility in production.

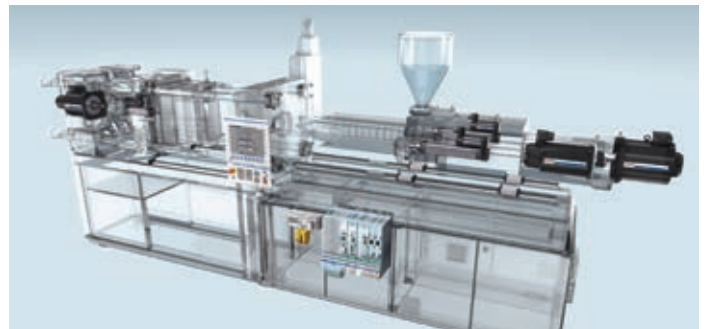
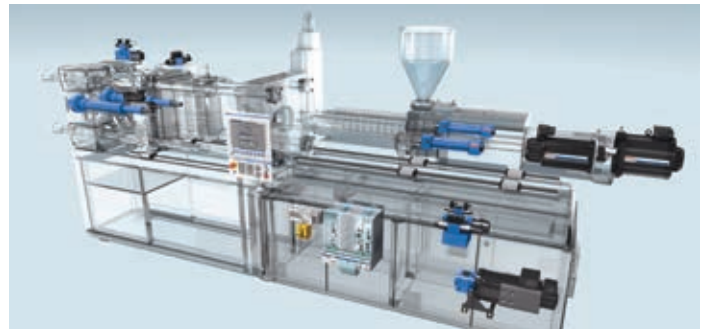

▲ **Hydraulic, hybrid and electric system solutions for injection molding machines**

**SAFETY  
ON  
BOARD**

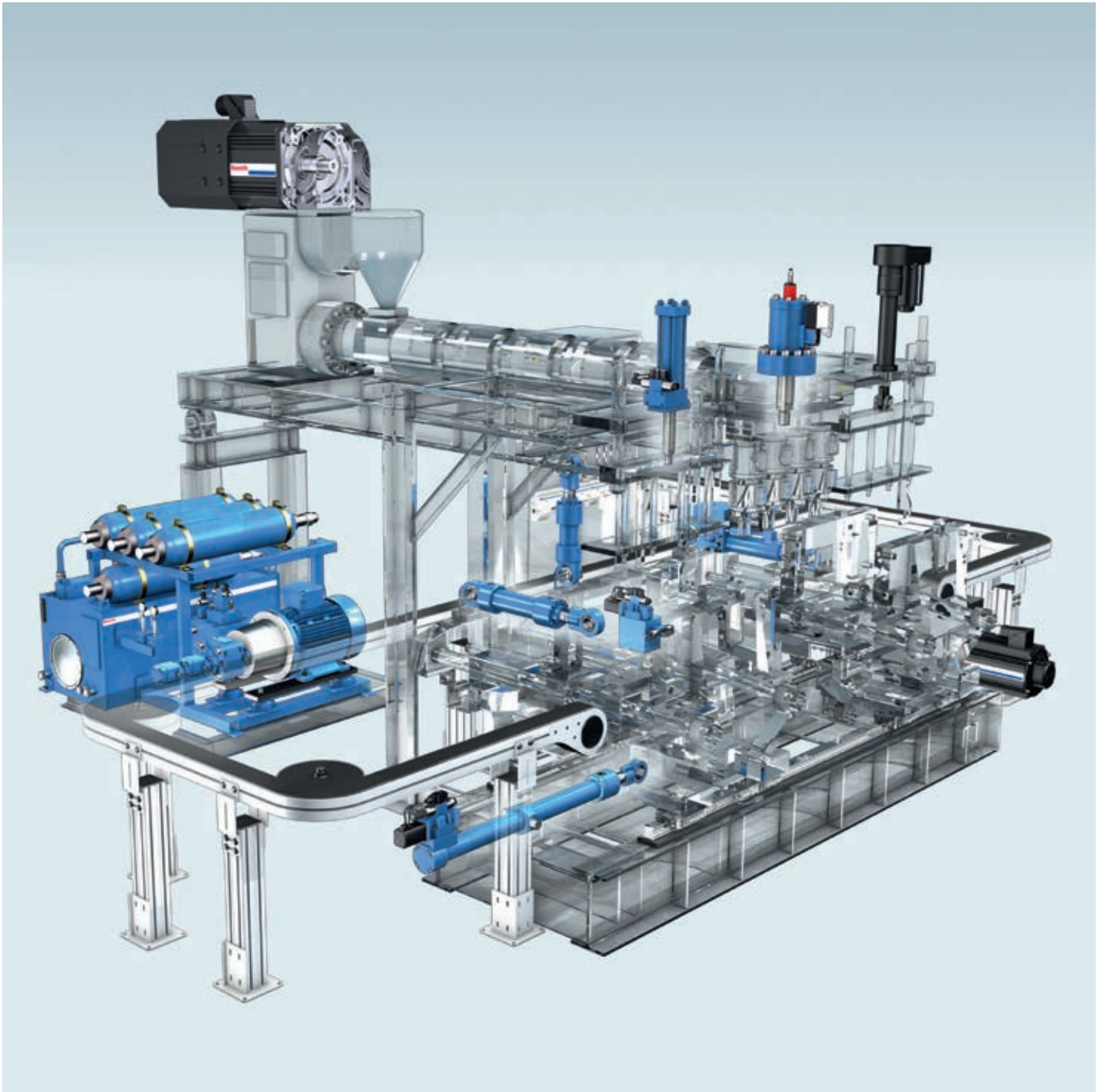

# Blow molding machines with short cycle times throughout the entire process

PET bottles, toys, gaiters or canisters: blow molding is the most efficient way to produce a number of products. Blow molding depends on extremely short cycle times and high repeat accuracy. Let us help you with our comprehensive process expertise.

## **Perfect interaction**

In blow molding machines, hydraulic and electric drives are closely intertwined. Consistent communication and perfect interaction between all components are that much more important. Rexroth is at your side with decades of experience with hydraulics, electric drives and controllers. We help you perfect the interaction of these technologies.

## **Compact and intelligent**

The high force density and flexible design of hydraulics provide unique advantages. They can be compactly installed in areas where space is a premium. The high degree of component modularity gives you the option of implementing a tailored solution for each task.

## **Parameterizing instead of programming**

Preset motion packages optimized to blow molding applications and designed for electric and hydraulic drives reduce the time spent on startup.

You can also dramatically increase energy efficiency with Rexroth drive and control solutions: with Sytronix variable-speed pump drives, intelligent energy recovery concepts for electric drives and by accumulating unneeded energy, you can reduce energy consumption by up to 80%, and with maximum productivity.

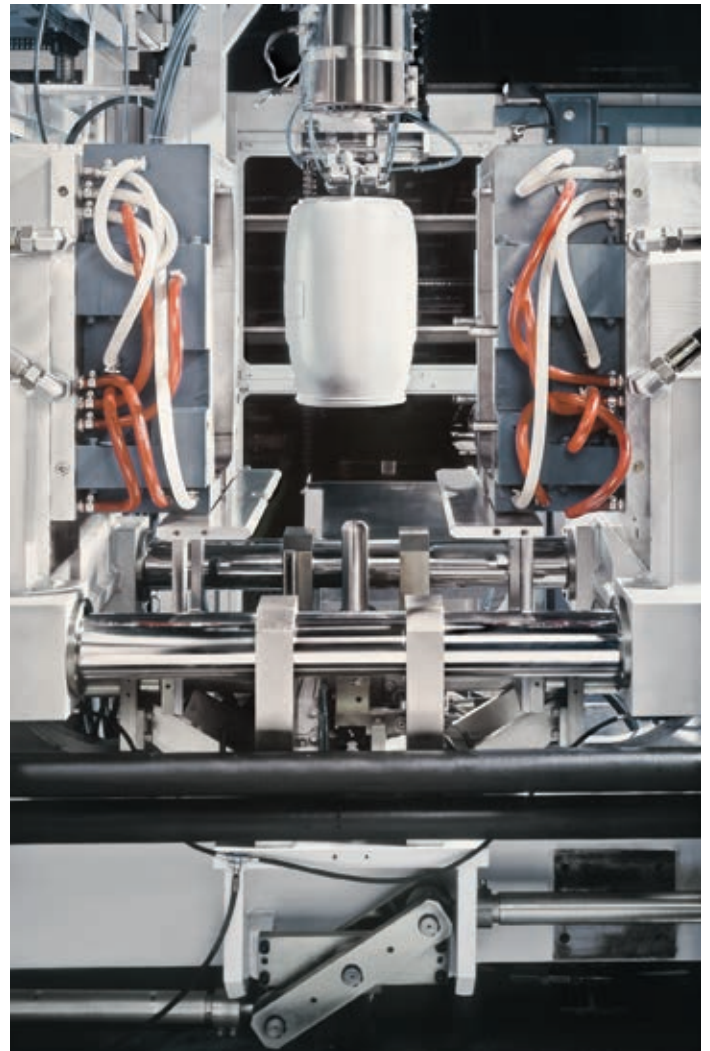

# Die casting machines with extreme repeat accuracy and short cycles

Cold- and hot-chamber die casting machines work non-stop with a high degree of automation. They produce large quantities and place special demands on repeat accuracy. Machine manufacturers are achieving dynamic processes that take milliseconds and involve extreme forces. We know how components and parameters interact. This is why we have developed special components and system solutions.

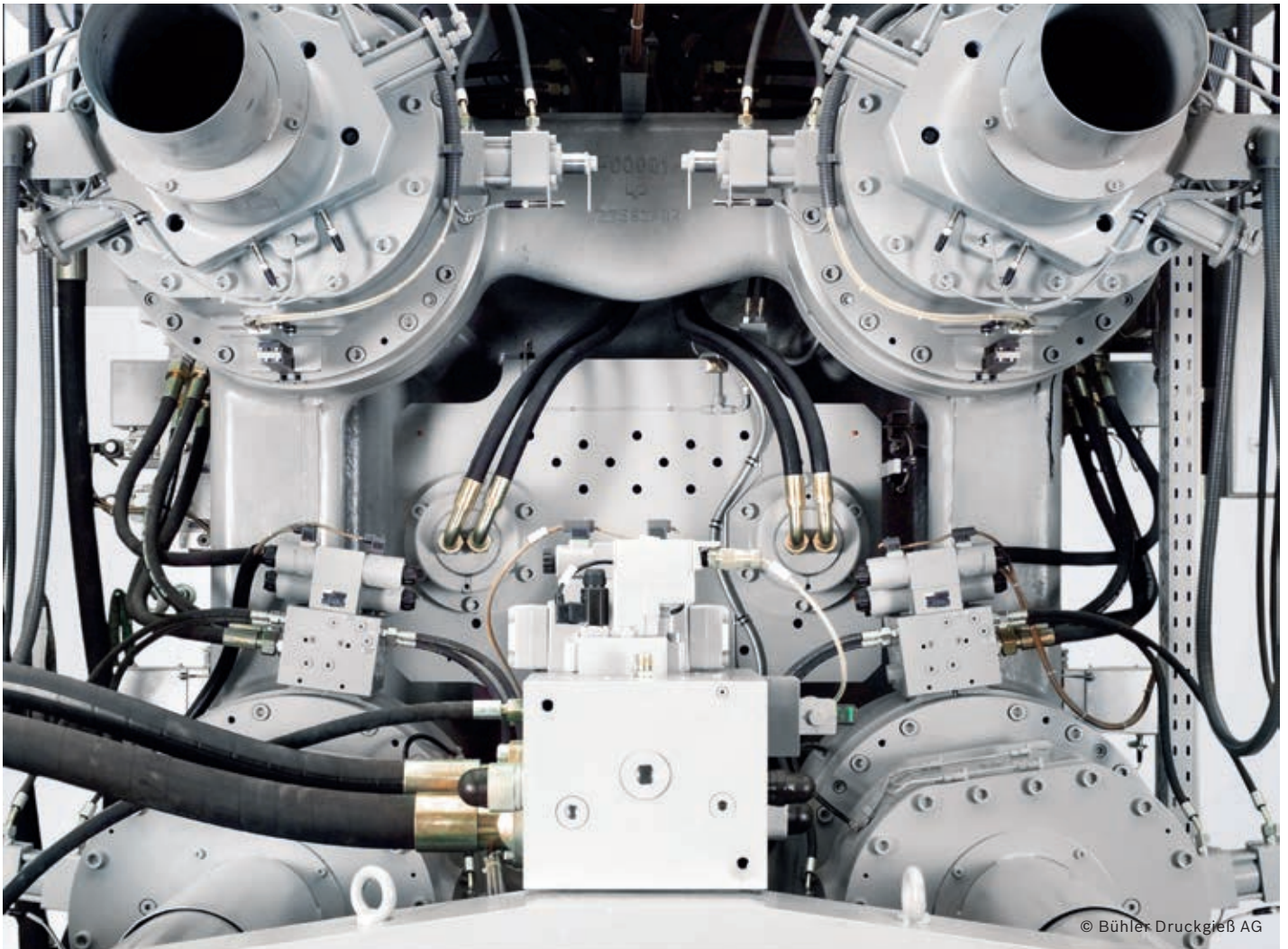

**Wearless and sensitive**

Die casting machines are indispensable in mass production due to their efficiency and robustness. Hydraulic drive technology contributes significantly to these aspects. It combines high power density with sensitive control and little wear. It extends the service life of die casting machines while reducing the amount of maintenance needed.

- ◀ **Clamping unit with control blocks by Rexroth**
- ▼ **Block diagram for the casting axis of a cold-chamber die casting machine**

**Flexible energy efficiency**

Major end users such as the automotive industry are relying more and more on lightweight construction and specifying new alloys and material combinations. This places higher demands on the controllability of flexibility of die casting machines. Rexroth offers one-of-a-kind experience with all drive and control technology. The spectrum ranges from highly configurable hydraulic components to modules with preprogrammed functionalities, to multi-technology system solutions. At the same time, all end users are striving to reduce energy consumption during production to save on costs and reduce CO<sub>2</sub> emissions. Sytronix variable-speed pump drives have allowed manufacturers of hot-chamber die casting machines to reduce installed power by up to 80%.

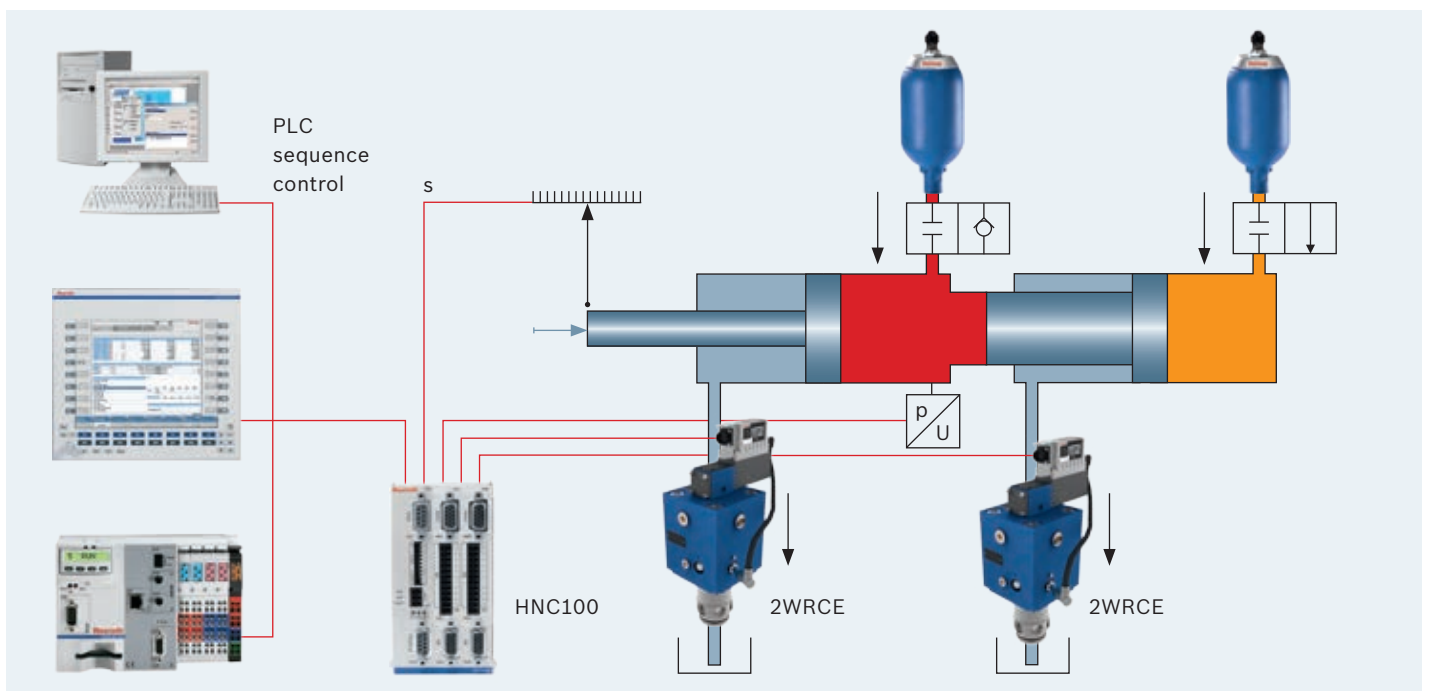

# Solutions from the same mold

With the high dynamics of die casting machines, the perfect sequence and combination of all motions is critical. We work with you closely, since the slightest change affects the entire process. Rexroth knows these interactions inside and out and can project them using internal simulation programs.

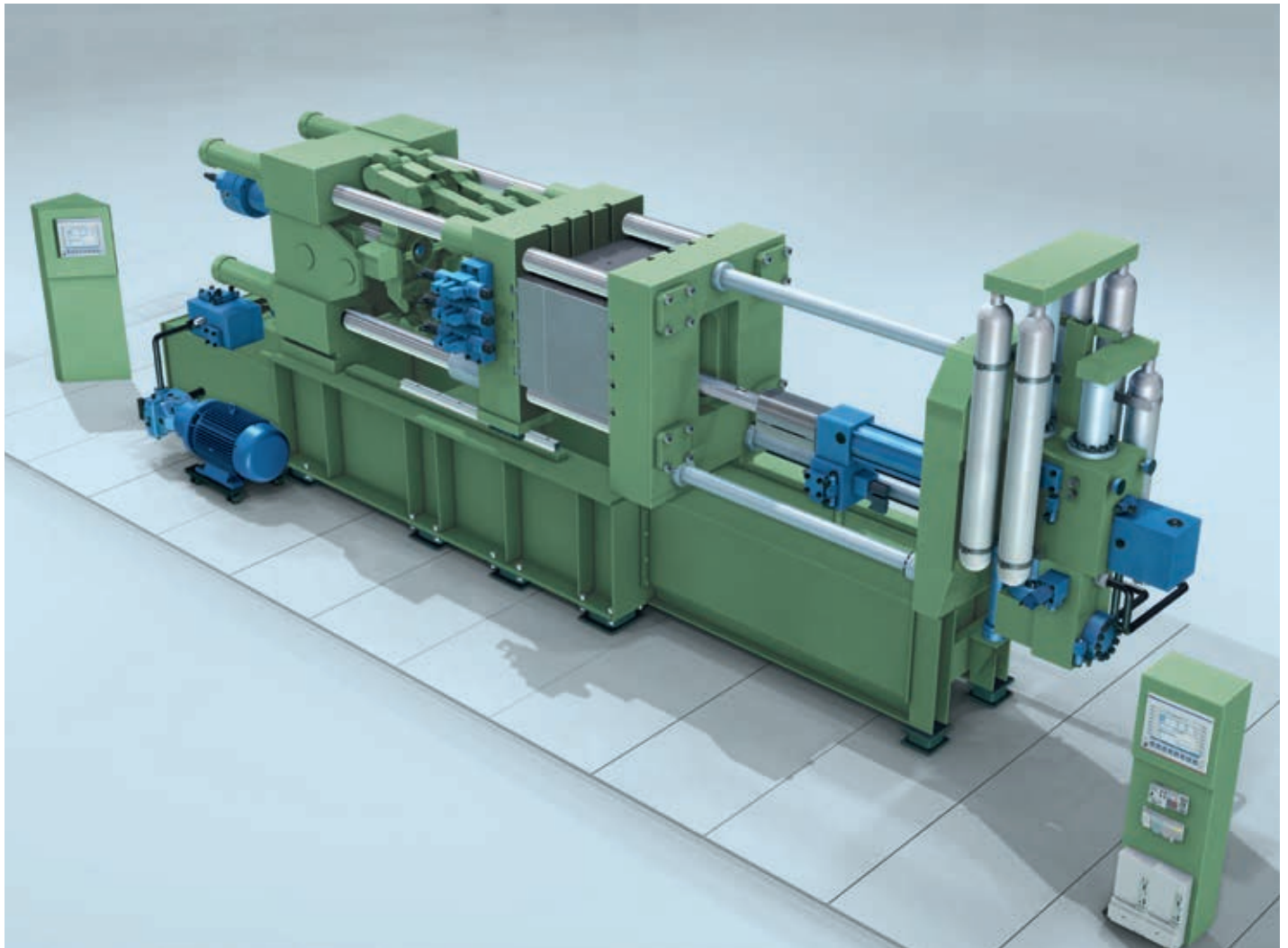

### System partner for all drive and control technologies:

Rexroth provides global support from as early as the conception stage with extensive application experience and helps you optimize your concepts at an early engineering stage. We give you a decisive competitive advantage, even during implementation: our system solutions are based on components optimized for die casting machines. We combine the advantages of hydraulics with digital controllers and open the door to new dimensions. Motion logic functionalities preset for the hybrid use of electromechanical and hydraulic drives replaces costly programming with quick parameterizing. This lets you save on engineering and startup costs.

The use of proportional active logic valves with check function reduces the number of parts, the dimensions of the inlet block, loss of inlet pressure in the shot cylinder, and costs. The highly dynamic pilot valve and integrated loop system increase dynamics, and reduce shot cylinder acceleration and pressure buildup (squeezing pressure) time. In conjunction with the active logic position sensor, excellent repeat accuracy can be achieved.

### Safe and energy-efficient

Non-combustible replacement fluids such as HFC are often used in die casting machines. Axial piston pumps type A4 by Rexroth are specially designed for these fluids and have the same service life as with using mineral oil.

Only Rexroth offers you all drives and actuators from a single source. They interact with one another perfectly. We also provide support on increasing energy efficiency and fulfilling all machine safety requirements with our application expertise. This gives you more time and ability to focus on what you're good at.



◀ Axial piston pumps by Rexroth are designed for use with non-combustible replacement fluids such as HFC and have the same service life as comparable pumps that use mineral oil



◀ Injection control valve with very fast proportional pilot valves with shock-resistant electronics for very quick regulating times during opening and closing as well as extreme repeat accuracy



◀ Active logic with check function – with its small active areas and flow-optimized pistons, it reduces closing time, along with pressure buildup time



◀ Proportional active logic with check function replaces conventional proportional flow control valves and the check valve in the injection cylinder inlet of cold-chamber die casting machines

# Sytronix family for tailored, variable-speed pump systems

Open or closed hydraulic circuit, different dynamics and performance requirements or intelligent axis control functions: your Sytronix system is tailored to your needs. More than 100 preconfigured system sets for almost any desire. And if that's not enough, we will work with you to create a custom solution.





**More detailed information can be found online at:**  
[www.boschrexroth.com/sytronix](http://www.boschrexroth.com/sytronix)

**Scalable performance and function**

The Sytronix family consists of a wide range of pumps, motors and controllers with preprogrammed software from a single source. We have incorporated our application experience into the software, which includes features of fluid technology. Sytronix drives achieve very high flow rates even in cascading systems and are designed for machines with multiple hydraulic circuits. We provide you with support even in the planning stage in the form of simulation models to assist you in designing and selecting your system.

The **Sytronix selection guide** shows you which Sytronix drives best meet your needs:

**Basic Dynamic**

Sytronix FcP systems with frequency-controlled pump drives are designed as a standard solution for constant pressure control in an open hydraulic circuit up to 90 kW.

**High Dynamic**

The Sytronix SvP servo-variable systems use the high dynamics of servo-synchronous motors for energy savings of up to 80%. They are available in combination with fixed or variable displacement pumps. The systems are designed for axis control tasks in both open and closed hydraulic circuits, and provide extensive electrohydraulic and electric control options.

**High Power & Dynamic**

The Sytronix DFE variable-speed drives give you more freedom with an additional pressure and flow rate controller on the pump. The use of variable displacement pumps makes DFE systems highly cost-effective, especially at high output, since the electric motor can often be smaller. They can be used for axis control tasks at high effective output in open and closed hydraulic circuits.

Requirements			Effective output		
			80 kW	90 kW	315* kW
Axis controller	Closed hydraulic circuit		SvP 7010	DFE 5010/7010	
	Open hydraulic circuit	One circuit per motor/pump			
		FcP 5010/7010			
Open hydraulic circuit					
Constant pressure system	Open hydraulic circuit				

\* More than 315 kW on request, previously limited by defined MOT-FC; larger converter in portfolio

# Dynamic, precise and energy-efficient drives

The power density and lack of wear of hydraulics combined with the energy efficiency and control options of electric servo technology: Sytronix variable-speed pump drives by Rexroth fulfill these requirements in every class and for a unique range of functions. They ensure the highest dynamics and precision in injection molding and die cast machines – with up to 80% less energy consumption and noticeably quieter operation.



**SvP system sets**

The Sytronix SvP system sets consist of a motor-pump group with a synchronous servomotor and a servo regulator. They offer top performance in terms of dynamics and control accuracy. SvP includes a wide range of established control functions that have been predefined in the software: pressure and force, flow rate, velocity and position, up to override control. They also increase the efficiency and availability of your machine concepts with additional functions, such as pressure pulsation compensation, energy monitoring or condition monitoring.

**Finely scalable up to 80 kW**

Sytronix SvP drives are finely scalable up to 80 kW with a flow rate of up to 480 l/min. Whatever your needs, they are an ideal solution: they can operate with an open circuit or with a closed circuit for four-quadrant operation. For very high power, simply set up a cascading interconnection in the system.

**Benefits**

- ▶ Multi-circuit and Master-Slave systems
- ▶ Available with coupling or compact direct attachment
- ▶ Low weight and reduced length since no additional couplings/motor brackets are needed
- ▶ Improved motor cooling thanks to optimized heat transfer from motor to pump
- ▶ Improved energy efficiency and dynamics thanks to a lower mass moment of inertia
- ▶ Lower noise emission
- ▶ Pre-assembled motor-pump group
- ▶ Simple startup and optimization thanks to predefined controller structures
- ▶ Safe to use thanks to integrated safety and monitoring functions
- ▶ Convection, forced air and water cooling

- ◀ **Sytronix SvP**
- ▶ **SvP block diagram**

**4EE**  
ENERGY  
EFFICIENCY

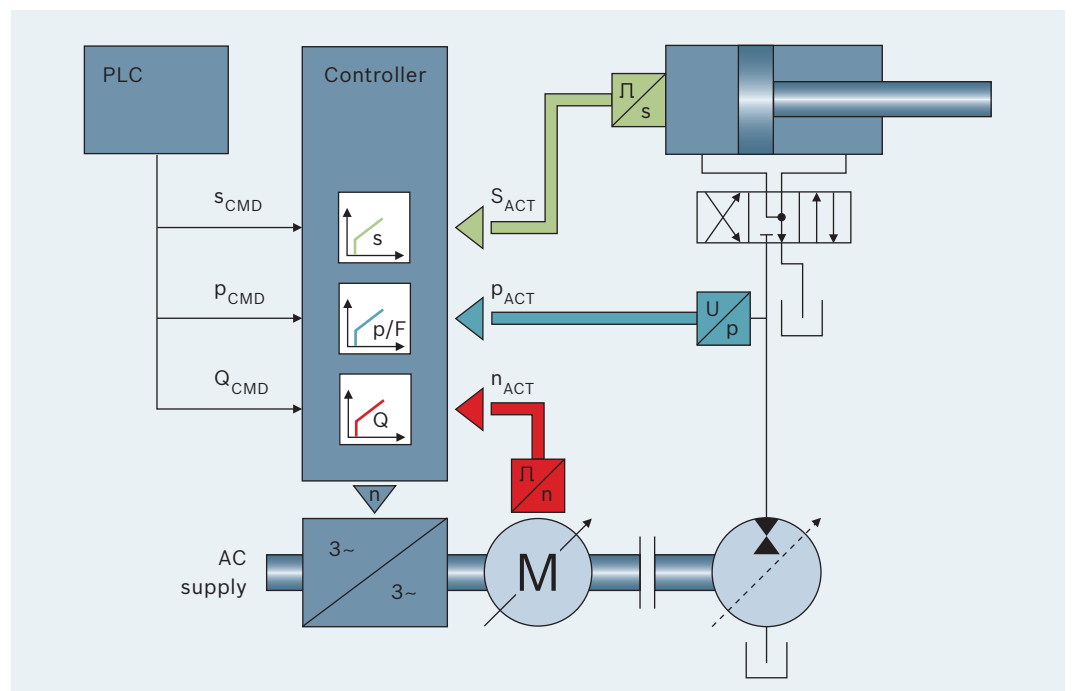

# Powerful and energy-efficient drives

Maximum freedom to implement energy-saving, complex motion tasks with intelligent controllers: the Sytronix DFE system sets consist of an electrohydraulically controlled axial piston pump driven by a variable-speed asynchronous motor. Standard motors up to 315 kW and the highly robust SYDFE pressure and flow rate control system give you a highly efficient solution up into the high power range.



**Cyclic and non-cyclic processes**

For non-cyclic processes, the Sytronix DFE system sets use the "real-time mode" function. The controller calculates the optimal combination of speed and pivot angle for the pump while the process is running to ensure the highest energy efficiency at all times. For cyclic applications, it uses the teach-in option to save the recurring pressure and flow rate profile in the electronics of the drive. Once loaded, your system will always accelerate just before an increase in flow rate.

**Smaller size saves space**

The variable displacement pump swivles back in constant pressure mode to reduce the flow rate and relieve strain on the motor. This allows the electric motor to be smaller in many application – with all the benefits from procurement to less installation space, to less energy consumption.

**Easy retrofitting**

And another thing: you can also efficiently retrofit installed SYDFE systems with the new Sytronix DFE system sets. The identical mechanical interfaces mean all you have to do is swap out the the pilot valve with integrated electronic.

**Benefits**

- ▶ Effective power up to 315 kW
- ▶ Multi-circuit and Master-Slave systems
- ▶ Constant pressure and axis control
- ▶ Easy retrofitting
- ▶ Rexroth A10 and A4 axial piston pumps
- ▶ Constant pressure with reduced torque and energy consumption

◀ **Sytronix DFE**  
▶ **DFE block diagram**

**4EE**  
**ENERGY EFFICIENCY**

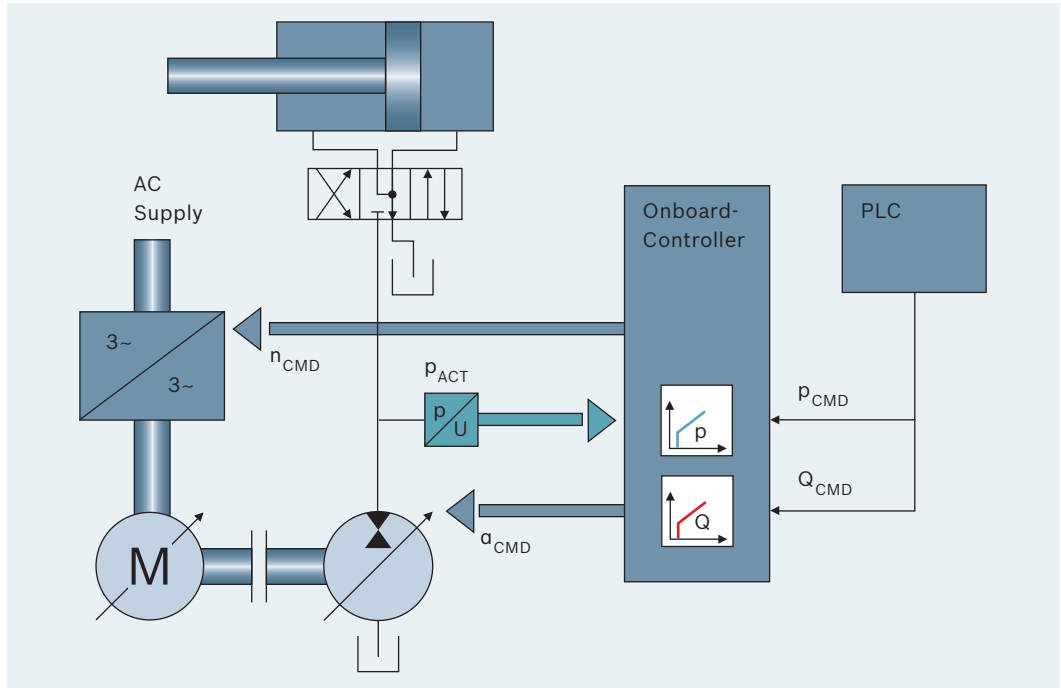

# Systematic energy efficiency



Higher energy efficiency with maximum productivity: this is what plastics and die casting machine users need. With the universal Rexroth for Energy Efficiency system, you can utilize the full energy-saving potential of all of your drive technology – and with the shortest cycle times.



Energy consumption matters to end users. More and more companies are striving to help protect the environment. At the same time, energy costs are accounting for an increasingly larger portion of total cost of ownership. The solution? Less energy consumption with maximum productivity. Rexroth understands both sides: as a company that creates products all over the world, we are dedicated to sustainably reducing our CO<sub>2</sub> emissions. Based on this experience, we have developed a universal system for utilizing the full energy-saving potential of all drive and control technology: Rexroth for Energy Efficiency. Rexroth 4EE looks at the entire machine system and distinguishes the following:

- ▶ Energy system design
- ▶ Efficient components
- ▶ Energy recovery
- ▶ Energy on demand

## **Energy-efficient designing**

Energy efficiency begins with looking at the system and taking every interaction into account. We work with you to simulate a wide range of configurations and provide you with a mechatronic support for minimal energy consumption. Our years of experience have shown us what is essential for your application. Our design tools help you avoid oversizing. This gives you the right power at the right time, all the time.

**Sytronix: energy on demand**

Intelligence makes all the difference: with predefined controllers, our variable-speed pump drives reduce the energy needs of your machine by up to 80%. Sytronix reduces the speed of the motor to save energy when under partial load, and can increase speed as needed quickly and accurately. The software automatically accounts for the hydraulic characteristics. The result is significant energy savings, lower noise emissions, and often a simpler hydraulic system.

**PWM plug: More economical, faster and cooler**

Plugs with pulse width modulation (PWM) reduce power needs and regulating time for switching valves. They simply shut off power consumption once switching is complete. The result is a power requirement reduced by up to 80% and significantly less heating of the valve surface.

**Smart Energy mode**

The intelligent energy management of IndraDrive power supplies with Smart Energy mode combines the benefits of several supply and recovery versions. The controller ensures DC voltage regardless of the line voltage, while using capacitors as energy accumulators. This prevents power surges in the line and reduces losses in the power supply line. The result is reduced energy consumption, better grid compatibility and smaller components while retaining machine performance.

**Other steps**

We will also take other steps with you to increase energy efficiency, from hydraulic or kinetic energy buffering to intelligent stand-by modes.

More information under [www.boschrexroth.com/4ee](http://www.boschrexroth.com/4ee)

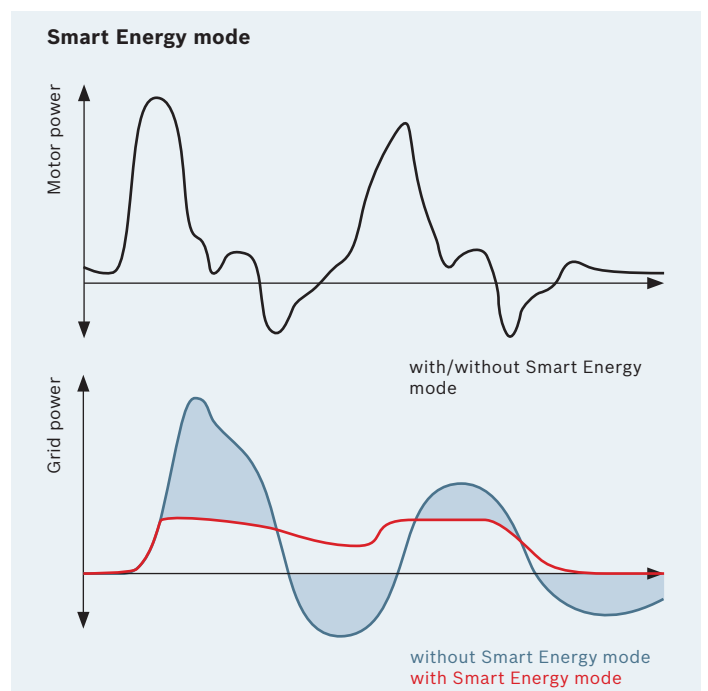
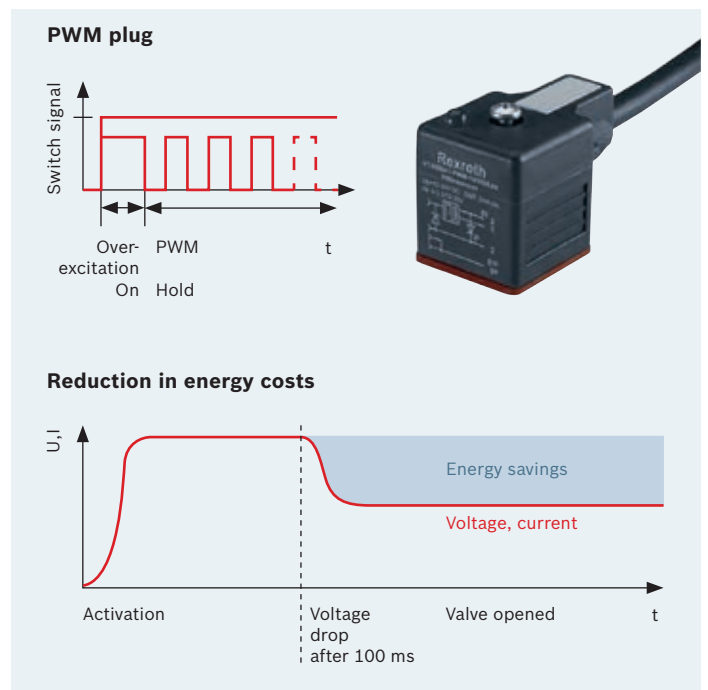

# Seamless interaction between hydraulics and electricity – with the right control technology

Hydraulics and control technology are moving closer and closer together. Rexroth is pushing this development and has added special fluid technology functions to the IndraMotion MLC motion logic system. Preprogrammed best-in-class controllers, a standardized engineering environment for the PLC, as well as the electric and hydraulic drives simplify your engineering. The result is a decisive reduction in your time to market.



At Rexroth, industrial, hydraulics and control system specialists have been working together for years. Their experience gained from thousands of plastics and die casting machines is also included in the software for this first motion logic system for electric and hydraulic drives.

## **Compatible with any architecture**

IndraMotion MLC combines an open PLC in compliance with IEC 61131-3 with a powerful motion controller. True real-time communication via the Ethernet-based Sercos automation bus supports both centralized and decentralized automation architectures. It also includes interfaces for all current forms of Ethernet communication and field-buses. This lets you combine the best components regardless of manufacturer.

## **Substantially simpler and quicker engineering**

The software standardizes the control of electric, hydraulic and hybrid drives. The IndraWorks engineering environment creates time-saving general conditions and a modular software structure at the start of the project. It contains every tool needed for planning, programming and parameterization, even diagnostics.

### Best-in-class controllers included

With centralized control concepts, a fast I/O module specially tailored for hydraulics forwards commands to the valves. This robust module meets all hydraulics-specific requirements, such as short-circuit and overload capacity.

Best-in-class controllers for centralized controlling of positioning, synchronization, force, overriding force/path controllers, and path-dependent braking cover all of the essential hydraulic functions. All you have to do is select the appropriate function block in the software.

In addition to the IEC 61131-3 programming languages, you can use sequential programming to execute cyclic and sequential tasks using the same language.

### Extensive diagnostic options

Regardless of the chosen programming language, the extensive diagnostic options provided by the Rexroth WinView tool makes troubleshooting and process optimization easier, especially for complex tasks. WinView records all PLC and process variables in up to 100 channels in real time, and continuously saves them to a PC as data logs.

### Built-in safety

With standard products, Rexroth offers functional safety across all automation levels and technologies. From component to system solution, we support machine manufacturers with safety solutions that minimize unproductive downtime. The drive-based SafeMotion solution gives the operator safe access to the process. With SafeLogic compact, we provide a modularly expandable, compact safety controller that is easy to use, and with SafeLogic, an optional expansion of the standard PLC with extensive safety peripherals.



- ◀ **IndraControl V multi-touch display – robust, reliable, designed for industrial use**
- ▼ **The IndraWorks engineering framework combines every tool for the entire engineering process – from planning to diagnostics.**



**More detailed information can be found online at:**  
[www.boschrexroth.com/mlc](http://www.boschrexroth.com/mlc)

### Multi-touch operation

Controlling machines and systems as you would at home: The new generation of IndraControl V control panels supports functions found in smartphones and tablets, such as zooming, swiping, moving or rotating. This saves on training time for end users and reduces the risk of operator error.

# Single- and multi-axis controllers for hydraulic axes

Supreme dynamics and precision: this is what is needed for the shortest cycle times. With a scalable portfolio of motion controllers, Rexroth gives you what you need to control axes in true real-time. The decentralized, intelligent controller electronics automatically account for the characteristics of hydraulics and simplify engineering with preprogrammed functionalities. Thanks to open multi-Ethernet interfaces, they can be integrated seamlessly into your concepts.



## **Multi-Ethernet reduces complexity**

Take advantage of the physical benefits of hydraulics with its high force density while reducing cost thanks to the engineering convenience of electric drives: Rexroth unifies both with a broad range of motion controllers for controlling hydraulic drives.

Single- and multi-axis controllers capable of real-time operation and cabinetless control electronics give you the freedom to choose from among the top Ethernet protocols such as Sercos, EtherCAT, Ethernet IP, PROFINET RT, VARAN and PROFIBUS DP. Each protocol is configured with the software. This reduces logistics, since one hardware version covers every option.

► **HMC with IndraWorks and internal visualization**



**Preprogrammed functions that only need parameterization**

The decentralized motion controllers control the hydraulic actuators with their own motion functionality according to the target value specified by the machine PLC. Preprogrammed best-in-class controllers for position, force, pressure, condition, velocity, as well as overriding controllers cover all current hydraulic functions.

Optimized algorithms and characteristic diagrams give you the freedom to adapt functions to new applications with flexibility. The software automatically accounts for the fluid technology characteristics. A broad range of hydraulic valves with onboard electronics quickly and accurately executes the commands of the motion controllers. This allows the hydraulic drives for the machine PLC to behave just like electric drives.

**One engineering environment for all drives**

Rexroth is blurring the line between drive technologies and simplifying your entire engineering process. You can start up all hydraulic and electric drives with one engineering environment: IndraWorks. It offers every available option for diagnostics, operation, and networking with higher IT systems. A broad range of hydraulic valves with onboard electronics quickly and accurately executes the commands of the motion controllers.



◀ **HNC100-3X: controller cycle time of 1ms/axis, controller electronics with special injection software for die casting machines (velocity and pressure control)**

- **Cat. 4, PLE safety PLC in compliance with EN 13849-1 (with corresponding system integration)**
- ▼ **IAC multi-Ethernet control valve with internal safety function, DGVU-tested**



**More detailed information can be found online at: [www.boschrexroth.com/motioncontrol](http://www.boschrexroth.com/motioncontrol)**

# Open Core Engineering: new freedom for custom control concepts

The trend is clear: modern mechanical engineering is transferring more and more functions to the software. Rexroth is leading the charge with more freedom than ever before and bridging the gap between the automation world and the IT world. But there's more. We have opened the core of our PLCs more than anyone else.





With Open Core Engineering, Rexroth has heralded in a new era: this interface technology, which won the Hermes Award in 2013, gives you more freedom than ever before. For the first time ever, you can create your own custom functions in high level language on standard PLC hardware and provide optimal protection for your expertise. Since we have opened up the core for increased access, your functions can even access it in real time.

Even smartphones and tablets can be seamlessly integrated into your automation. Programs for startup, diagnostics and operation access the PLC without needing to modify the PLC program. The result is a system that is already familiar and easy to use, and reduces training costs.

### Efficient engineering

In PLC automation, Open Core Engineering reduces your engineering costs thanks to open standards, software tools and complete function packages. We have also predefined common machine functions so that you only need to parameterize them.

Our PLC portfolio contains a wide variety of PLCs that can be scaled in terms of power and function. These motion logic systems use universally open standards, such as a PLC under IEC 61113-3 or OPC-UA. Our automation systems are equipped with multi-Ethernet interfaces to reduce complexity.

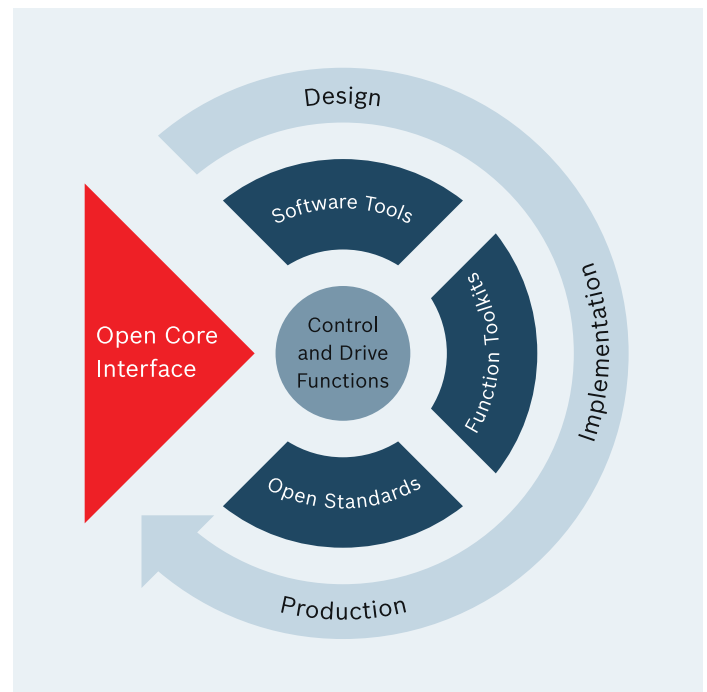

◀ **Technology Innovation Award 2013 at the Hanover Fair for Open Core Engineering**

**More detailed information can be found online at: [www.boschrexroth.com/oc](http://www.boschrexroth.com/oc)**

# Self-contained, hydraulic servo axes eliminate tubing entirely

Centralized or decentralized: Rexroth has intelligent solutions for both. In addition to electromechanical solutions, self-contained, electrohydraulic servo axes are seeing increasing use. They combine the physical advantages of hydraulics with decentralized control concepts. Sytronix variable-speed pump drives also make them highly energy-efficient.

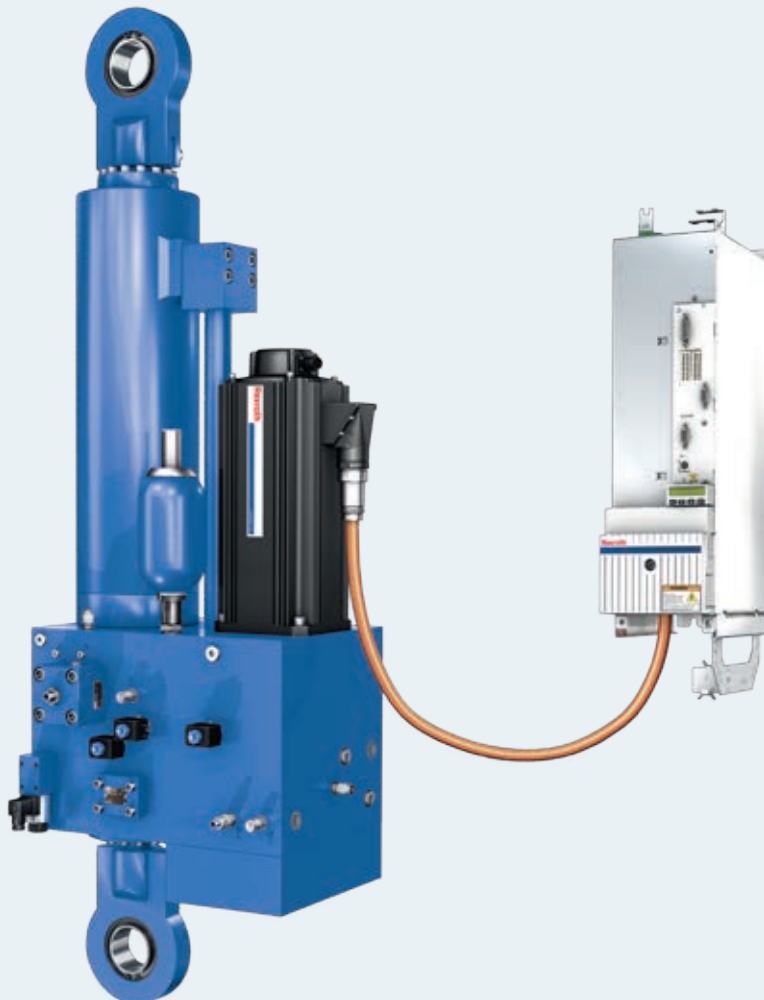

- ◀ **SHA** – self-contained, electrohydraulic servo axis, up to 1.0 m/s and 1,000 kN
- ▶ **EMC-HD** – self-contained, electromechanical servo axis, up to 1.0 m/s and 250 kN

**4EE**  
ENERGY  
EFFICIENCY

**SAFETY  
ON  
BOARD**



### Benefits

- ▶ Easy engineering with pre-assembled systems
- ▶ Low design costs: simple integration into machine concepts
- ▶ Install in any position
- ▶ Reduced overall installation space
- ▶ Minimal number of parts
- ▶ Free of tubing, no external hydraulic lines
- ▶ Complete plug-and-run system
- ▶ Multi-axis applications, synchronization control, and much more
- ▶ Free switch between rapid travers and force function
- ▶ Holding of full load without external drive energy
- ▶ Option for higher positioning accuracy
- ▶ Simple condition monitoring
- ▶ Process data recording the process documentation
- ▶ Effective product switchover with simple parameterization
- ▶ Potential sources of faults in machine minimized

### Ready-to-install axes just need to be connected

The self-contained, electrohydraulic servo axis is a plug-and-run solution for linear motions. It does not need any central hydraulic power unit and eliminates the need for tubing. The ready-to-install modules have everything onboard: a completely closed fluid circuit, a control block with digital valves and a switchable multi-surface cylinder. Pressure and position are controlled by a variable speed pump drive integrated on a block mounted directly on the cylinder.

### Virtually silent motion

Digital implementation throughout, from actuation to controller, variable-speed pump drive and valve controller, to the digitally switchable cylinder with rapid traverse and force function, opens up new possibilities. They take advantage of all of the benefits of hydraulics, such as wear-free linear motions, high forces, dynamics and precision – and all this with energy efficiency and almost no noise.

The axis can even continue working when the motor is off. The system also does not need any external drive energy when stopping a full load, so motor noise is eliminated entirely.

### Pre-assembled electromechanical cylinders

We have developed the EMC-HD electromechanical cylinders specifically for use in heavy-duty applications. These pre-assembled systems, with ball and planetary screw drives, are also available as a plug-and-run solution with an intelligent servo drive and a multi-Ethernet interface.

# Simulation, planning and configurators: knowing the result right from the start

More and more machine manufacturers are relying on simulation programs to optimize their machines. However, most programs only cover subsystems and do not account for fluid technology characteristics. As your system partner, Rexroth provides support with our own simulation programs that incorporate all of our shared application experience.



**Impartial consulting**

Our industry specialists guide you from the initial idea, to each engineering step, all the way to startup. We take your needs and turn them into tailored solutions. During this process, we consult you on the most efficient, best solution for each task, even if that solution is not ours.

**Component knowledge and system experience**

Not too many, not too few: selecting components is always a tightrope walk. We give you the confidence of choosing the right performance and function for every task. To do this, we use state-of-the-art design tools to avoid oversizing and undersizing every time. And above all, our decades of experience tell us exactly what your machine needs. This lets us turn our extensive component knowledge into complex machine functions.

**Configurators**

The configurators by Rexroth allow you to configure quickly, easily and directly online without needing to be an expert. Here are some examples:

- ▶ HSR multi-station manifolds: users no longer have to select a material number or description, simply relay their needs directly through the circuit diagram. The components always fit thanks to integrated collision testing and correction.
- ▶ ABAPG motor-pump groups: Drive units are configured custom with the best product and without design changes. 3D data makes them easy to implement into each application.
- ▶ Filters
- ▶ Cylinders
- ▶ Electric drives (IndraSize)
- ▶ Circuit diagrams (Interactive Fluid Office)

**Solid basis for simulations**

We test our recommendations using simulation programs developed in-house that also account for fluid technology characteristics. We verify your application in regard to achievable dynamics during normal operation, as well as during extreme and emergency situations. We then recommend control concepts and how to parameterize them.

The advance virtual startup can even eliminate the need for expensive prototypes in some instances. This allows you to test extreme situations that cannot be tested in real life. Potential problems are recognized early and can be rectified with minimal effort.

# From component to system solution, we are your partner for any drive and control task

Avoid complexity and rely on best-in-class components for every drive technology. Rexroth offers an extensive portfolio of hydraulic components, electromechanical drives, even entire system solutions with preprogrammed software functions. Enjoy top performance, coordinated interfaces and guaranteed quality from Rexroth.



- ◀ **IndraMotion for electric and hydraulic drives**
- ◀ **IndraDrive scalable drives**
- ◀ **IndraControl V multi-touch control and visualization unit family**



- ◀ **IndraControl XM22**
- ◀ **HACD-2x digital control electronics**
- ◀ **IndraDyn T torque motors**

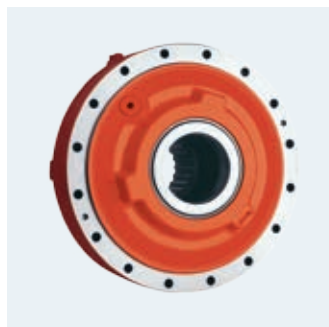

- ◀ **IndraDyn S synchronous servomotors**
- ◀ **Hägglund heavy-duty direct drive**
- ◀ **Sytronix variable-speed pump drives**

**The Rexroth portfolio**

- ▶ PLCs
- ▶ Hydraulic PLCs and control electronics
- ▶ Hydraulic actuators (cylinders/motors)
- ▶ Hydraulic power units
- ▶ Sytronix variable-speed pump drives
- ▶ Standard, linear and torque servo motors
- ▶ Ball and planetary screw drives
- ▶ Heavy-duty guides
- ▶ Heavy-duty electromechanical lifting cylinders
- ▶ Scalable motion logic systems
- ▶ Handling system toolkit
- ▶ Fluid filter systems and elements
- ▶ Application-based system solutions
- ▶ Special customized solutions



**Online product overview:**  
<http://www.boschrexroth.com/en/xc/industries/machinery-applications-and-engineering/plastic-machinery-and-die-casting/products-and-solutions/product-overview/injection-molding-machines-2>



◀ **SY-DFE – electrohydraulic control system for pressure and flow rate**

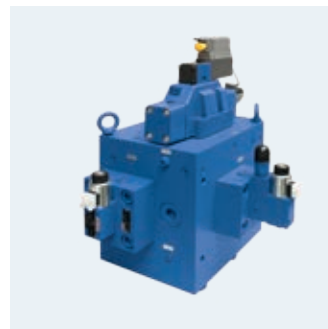

◀ **WRCE cartridge control valve**  
 ◀ **4/3 proportional directional control valve**  
 ◀ **Control block for controlled clamping unit**

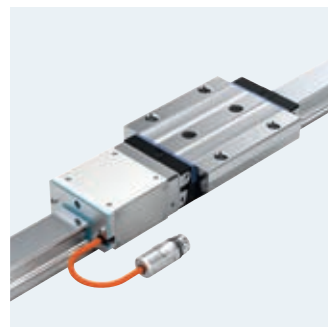

◀ **Hydraulic axis with IAC-R**  
 ◀ **Linear technology, e.g., PLSA planetary screw drive**  
 ◀ **Heavy-duty roller rail system with integrated measuring system**

# Use hydraulic fluids longer with optimal filtration

Extend the service life of hydraulic fluid and prevent damage: Rexroth helps you with the fluid management of your machines and systems with filter solutions, online monitoring and expertise.

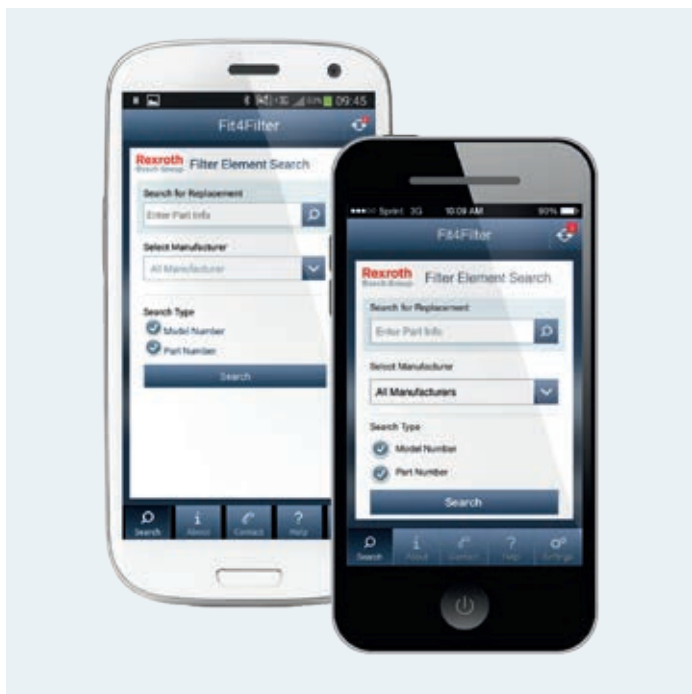

Particles and water impact your fluid and cause it to age prematurely. Rexroth helps you keep an eye on the condition of your hydraulic fluid at all times. Our new OPM II online particle monitor checks and documents the level of contamination. When tolerances are exceeded, the alert allows swift action to be taken to prevent damage.

## Fit4Filter

The filter program from Rexroth perfectly suits all needs. It includes the Fit4Filter filter app for smartphones and tablets, which makes it easier to quickly select the right filter elements. The element database contains over 30,000 filter elements from various manufacturers. Just enter the item number or use the QR code. The app instantly finds the right Rexroth filter element and, if desired, directs you to ordering.

Download Filter App free

Android



iOS



- ◀ Online particle monitor
- ▶ Extensive replacement filter program

More information:  
[www.boschrexroth.com/filter](http://www.boschrexroth.com/filter)



# Develop employees with basic and advanced training

Understand the latest technology in order to use them efficiently and safely. At the Rexroth Drive & Control Academy, we give your employees practical training in all drive and control technologies – either on-site or online.



More information:  
[www.boschrexroth.com/academy](http://www.boschrexroth.com/academy)



As a manufacturer of every drive and control technology, we have one-of-a-kind expertise in the automation of systems and machines. But that's not all. The Bosch Group is one of the world's largest trainers for technical occupations at over 270 production sites on every continent. Our own experience always keeps us up to date on the latest content and methods for efficient basic and advanced training. With this basis, we offer you a comprehensive, global product and service program centered around basic and

advanced technical training and qualification.

## **Drive & Control Academy**

The Drive & Control Academy provides you with one-of-a-kind Rexroth expertise for every drive and control technology. Take advantage of our range of specially adapted training sessions to give your technical experts advanced training and qualification.

# Expand your service offering

We will help you expand your service portfolio and keep your customers coming back for years: with quick replacement part delivery, error diagnostics for drive and control systems, even updating. And best of all: we're at your side in over 80 countries.



Why have more personnel and spare parts than needed? Rexroth helps machine manufacturers build an extensive, global service offering with minimal structures. We identify the right replacement parts and send them to you quickly through regional logistics warehouses. Our certified workshops make professional repairs to hydraulic and electric components and modules – quickly, efficiently and with a warranty as if new. We also offer various service agreements to extend the serviceability of older systems beyond the norm.

Local drive and control specialists from Rexroth help your service personnel diagnose errors – on the phone, online, or on site. We provide any hydraulic and electric drive and control service, even for retrofitting or updating machines and systems.

Take advantage of what we have to offer to expand your service business – we offer tailored solutions to meet your needs.



**Spare Parts**



**Repairs**



**Field Service**



**Modernization and Retrofit**



**Service Agreements**

More detailed information can be found at  
[www.boschrexroth.com/service](http://www.boschrexroth.com/service)





Tough application,  
ingenious solution } Exactly

### Your benefits

- ✓ Impartially configured
- ✓ Motion profiles optimized
- ✓ Communication simplified
- ✓ Productivity maximized
- ✓ Energy efficiency increased
- ✓ Operating costs reduced

**Bosch Rexroth AG**

Zum Eisengießer 1  
97816 Lohr, Germany  
[www.boschrexroth.com](http://www.boschrexroth.com)

**Find your local contact person here:**

[www.boschrexroth.com/contact](http://www.boschrexroth.com/contact)