

VT-HACD-1 – Digital controller for electromechanical and electrohydraulic drives

RE 30143-B/09.13
Replaces: 08.07

Installation and Operation

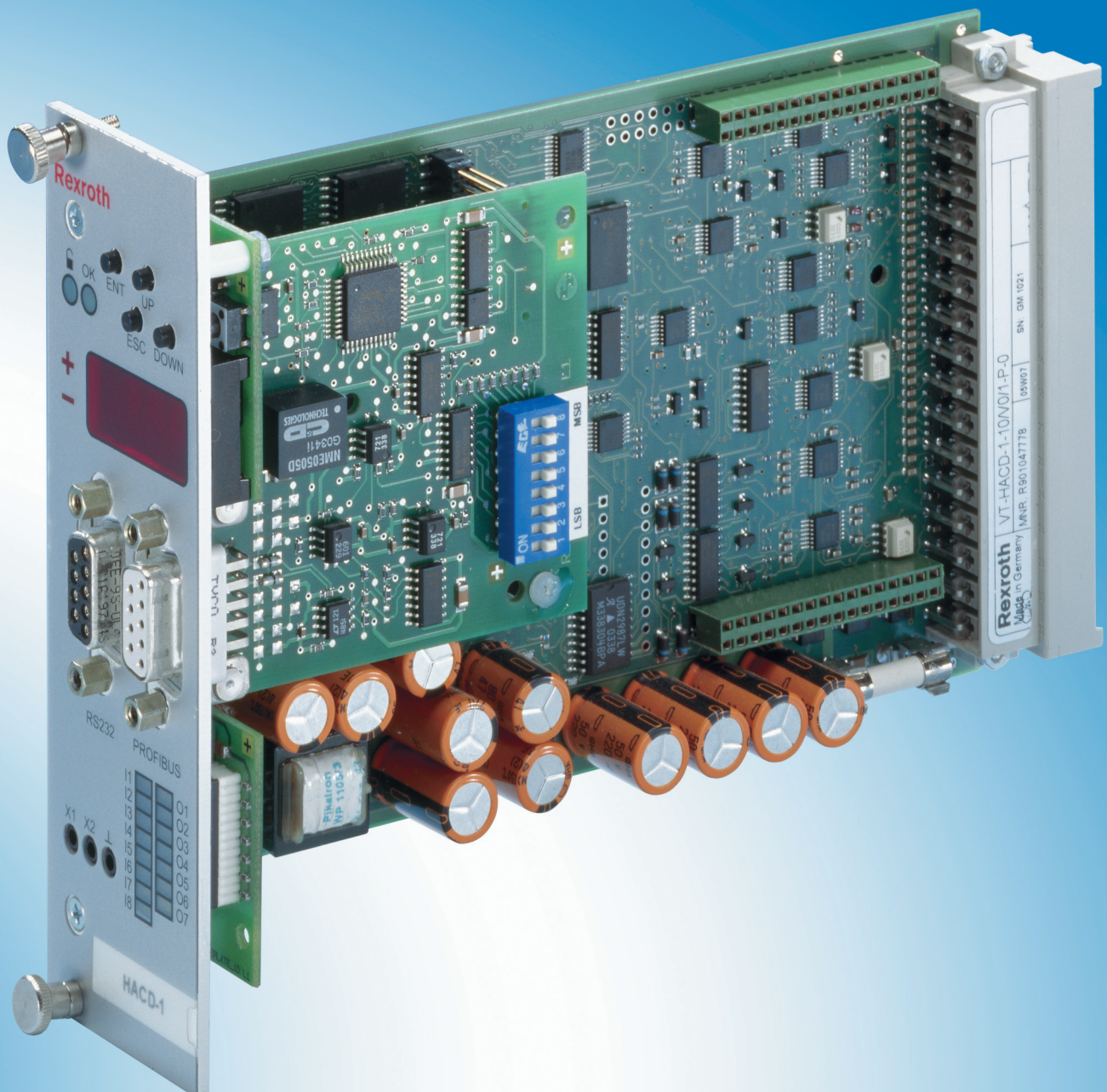

Contents

1	General	5
1.1	About this Manual	5
	Additional Documentation.....	5
	Characters and Symbols.....	6
1.2	Scope of Supply	6
1.3	Requirements.....	7
2	Installing the HACD	8
2.1	Safety Requirements	8
	Proper Use.....	8
	Personnel Selection and Qualification.....	9
	Design Changes and Electrical Installation.....	9
2.2	Repair and Troubleshooting	10
2.3	Transport, Storage and Handling the Controller Card	11
2.4	Card Installation	12
2.5	Edge Connector Terminals and Pin Assignments.....	13
2.6	Installation Local Bus	17
3	Startup of the HACD Controller Card	18
3.1	Preparing for Use	18
3.2	Installing BODAC software	19
	Installation Requirements.....	19
	BODAC Setup	19
3.3	Initial startup with BODAC	20
4	HACD Operation	21

4.1	Display/Input Keys and Connectors on the Front Panel	21
4.2	Diagnostics Test Jacks	23
4.3	Menu Tree for Setup and Parameters	24
4.4	Display/Input Key Operations	35
5	Diagnostics	40
5.1	Diagnostic Options on the HACD Controller Card	40
5.2	Diagnostics Using BODAC	41
6	Detecting Errors	42
6.1	Error Messages	42
6.2	Changing fuses	43
7	Index	45

1 General

1.1 About this Manual

Before installing or operating your HACD Controller card for the first time, you should read this Manual. Please note the safety requirements described in section 2.1

Persons involved with the start-up and operation of the controller card should have proper training on the installation and operation of this type of equipment.

This manual is intended to inform you about the functions of this controller card and its intended use.

The Manual contains important safety instructions on proper installation and operation of the controller card. Observing these instructions will help you:

- avoid hazards and dangers
- minimize repair costs and downtime
- increase the useful life and reliability of the controller card.

Additionally, please observe all regulations that are in effect in the country and/or community to prevent accidents and to protect the environment.

This manual only describes the installation and operation of the controller card. Information about starting up the controller card using BODAC software is located in a separate document: "Operation of the BODAC Software and Starting up the HACD Control Card". A list of documentation for the HACD can be found in the "Additional Documentation" section.

Additional Documentation

Included with this manual is the document "HACD Digital Controller for Electromechanical and Electrohydraulic Drives".

It contains:

- RE sheet "RE 30 143" in paper form.
- Document RE 30 143-B: "Starting up the HACD Control Card and Operation of the BODAC Software" (included with the shipment).
- Internet: <http://www.boschrexroth.com/hacd>

1 General

Characters and Symbols

The following characters and symbols are used in the manual:

- Action symbol: The text following this symbol describes actions. These should be performed, from top to bottom, in the given order.
- ✓ Result symbol: The text following this symbol describes the results of an action.



Following this symbol you will find notes and useful tips for optimal use of the controller card.

Warning symbols Special safety notes are provided at the relevant locations. These are indicated by the following symbols.



General hazard potential

Indicates a potentially hazardous condition which, if not avoided, could result in death or serious injury.

If the hazard source can be specifically indicated, the corresponding pictogram will be used.



Electrical current hazard

This symbol refers to a hazardous condition caused by electrical current which, if not avoided, could result in death or serious injury.



Equipment damage

This symbol pertains to actions which could result in damage to equipment.

1.2 Scope of Supply

The equipment is packed in anti-static packaging to protect the controller card from electrostatic discharge. Observe instructions on the top side of the packaging.

Included in the shipment:

- HACD Controller Card
- RE sheet RE 30 143

1.3 Requirements

Mounting the controller card in an open card holder

- VT 3002-2x/G64

described in datasheet RE 29 928.

The card holder should be used only inside a control cabinet, as there is no protection from accidental contact.

If no power is provided by the user, the following power supply is available as an option:

- VT-NE30

described in datasheet RE 29 929.

2 Installing the HACD

2 Installing the HACD

2.1 Safety Requirements

Operate the HACD controller card only if it is not damaged and is in proper operating condition and is applied for its intended purpose. Observe all safety and hazard instructions in the included documentation.

When faults occur, which compromise safety and result in changes in operating conditions, shut down the controller card immediately and notify responsible personnel.

Fault free and safe running of the controller card assumes appropriate transport, storage and installation, as well as proper startup and operation.

The HACD Control Card has been built using the latest technology, and in accordance with recognized safety standards. Nevertheless, operation may result in hazard to persons or property if:

- The HACD Controller Card is not used properly.
(see page 8, Proper Use)
- The HACD Control Card is not installed, commissioned and operated by qualified persons.
- Changes or modifications are made to the HACD controller card.
- Safety requirements and safety notes are not observed.

The HACD controller card is intended for industrial use.

The card must not be operated until it has been determined that the system in which the controller card is installed, meets all applicable standards and safety regulations for the application.

In European countries: EC Directive 89/392/EWG (Machine Directive)

Operation is permitted only when applicable EMC regulations for the application are met.

Adherence to limits defined by regulations and standards are the responsibility of the manufacturer of the system or machine.

In European countries: EC Directive 89/336/EWG (EMC Directive)

In the United States: National Electrical Code (NEC) and National Electrical Manufacturers Association (NEMA), as well as local standards should be observed. The operator is required to adhere to the above named standards at all times.

Proper Use

The HACD controller card is designed for controlling electromechanical and electro-hydraulic drives.

Applications include:

- open loop control
- closed loop position control
- closed loop speed control
- closed loop pressure and force control
- valve controller

Proper use requires adherence to the manuals and supplementary documentation, and observing relevant safety and operating standards.

Personnel Selection and Qualification

Operating and Startup Operation and startup of the HACD controller card requires specialized skills. Therefore this work should be performed only by properly trained individuals.

Only persons who are trained or properly instructed should start up and operate the HACD controller card. Additionally the oversight of a qualified supervisor may be advised.

Personnel are considered qualified if they are familiar with the installation, startup and operation of the HACD controller card, and with all the warning notes and safety regulations contained in the accompanying documentation.

Work on the electrical equipment must be performed only by qualified specialists or by personnel appropriately instructed and under the supervision and guidance of persons qualified and familiar with electrical safety standards.

An electrical specialist is someone who, based on his technical knowledge and training, as well as knowledge of the relevant standards, is able to evaluate the tasks assigned to him, recognize potential hazards and take the appropriate safety measures.

Repair and troubleshooting Repair and troubleshooting requires specialized skills. Therefore, this work should be performed only by trained and designated specialists.

Design Changes and Electrical Installation

User changes to the HACD controller card may result in safety hazards.

Note the following recommendations on electrical installation:

- Use low-capacitance cables. Make cable connections without intermediate connections whenever possible.
- Control electronics should be isolated from electromagnetic noise sources (IE: V/F drives).
- Power wiring should not be routed in the vicinity of control electronics.
- Power wiring should not be routed in the vicinity of control wiring or cables.
- Route sensor lines separately.
- Maintain a distance of at least 1 meter from antenna lines, RF devices and radio equipment.
- When using differential inputs switch both inputs on and off at the same time.

2 Installing the HACD

- When switching signal inputs, use dry circuit rated relays with gold-plated contacts (low voltages, low currents)
- Always shield all analog signal lines. Connect shields at the card end only, connecting to the "Shield" terminal, and leave the other end open to prevent ground loops.
- Connect to an appropriate system ground using stranded copper wire (min 2.5mm² / 12 AWG)
The system ground is an essential component of the EMC protection for the controller card. The ground provides a path for noise that could otherwise enter the controller card through the signal and power supply lines. Noise is bypassed only if the system ground does not couple noise into the controller card.
Rexroth also recommends shielding solenoid wiring.
- Do not use logical signals from the controller card (IE: "OK" signal) for switching machine safety circuits
(see European Norm "Safety Requirements for Fluid Power Systems and Components" EN982:1996).

2.2 Repair and Troubleshooting

If the control cabinet contains additional electrical components utilizing high voltage, always observe safety standards to prevent accidents ! Use appropriate protective gear, such as safety shoes and safety gloves, when prudent !

Use appropriate tools (IE: insulated tools)

Before opening control cabinet doors, open the main disconnect.

To ensure safe working conditions, observe the following safety rules:

- Remove all power
- Ensure against unintended energization: lockout devices when possible, and use lockout warning tags
- Verify that voltage is not present
- Cover or close off adjacent areas that are still energized.

If work on energized components is necessary, have a second person present as a safety backup to actuate an E-STOP switch or open the main disconnect, if necessary. Use insulated tools only.

2.3 Transport, Storage and Handling the Controller Card

The packaging contains notes on handling of the controller card. These must be strictly followed.

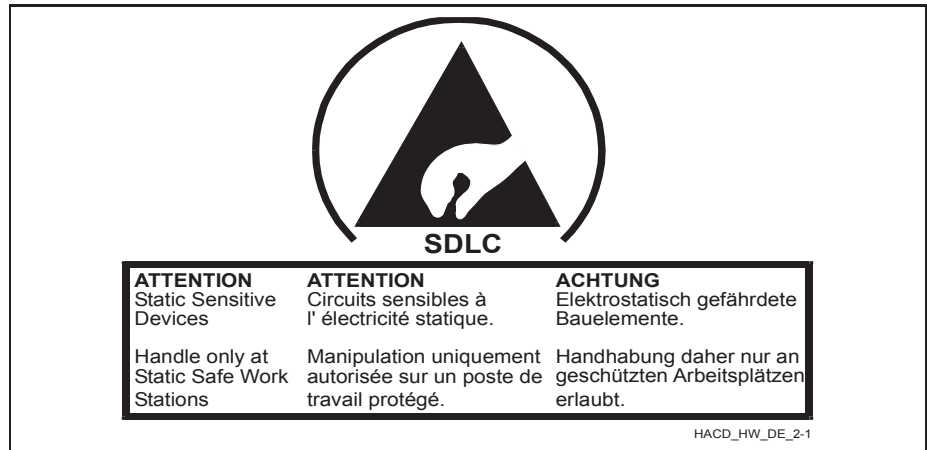

Fig. 1 Notes for handling printed on the packaging

Observe the following:

- Keep the controller card away from moisture and dust
- Observe the allowable storage temperature range of -20°C to $+70^{\circ}\text{C}$. (allowable operating temperature: $0 - 50^{\circ}\text{C}$)



NOTE!

Electrostatic discharge (ESD) can damage components on the controller card. To prevent damage, observe the following recommendations

Discharge static voltage from your body using accepted practices.

Work in a safe environment. Do not use any devices in the working environment that generate or hold static charge. Avoid working with the controller card in areas where floors or work surfaces is composed of materials that can generate a static charge.

Handle the controller card carefully. Do not touch any exposed pins or electronic components.

Transport and store the control card in its original packaging.

2 Installing the HACD

2.4 Card Installation

Remove the card from its packaging only at a protected work place.

Do not touch any electrical components when placing the controller card in its proper card holder as shown in Fig. 2..

Correctly installing the HACD controller card:

- Remove power from the rack when installing the card.
- Hold the card by the front panel and remove it from the packaging.
- Slide the card into the guide rails of the rack without using excessive force, as shown in Fig. 2 “Installing the control card”.
- Snap the edge connector in place by gently pressing on the front panel.

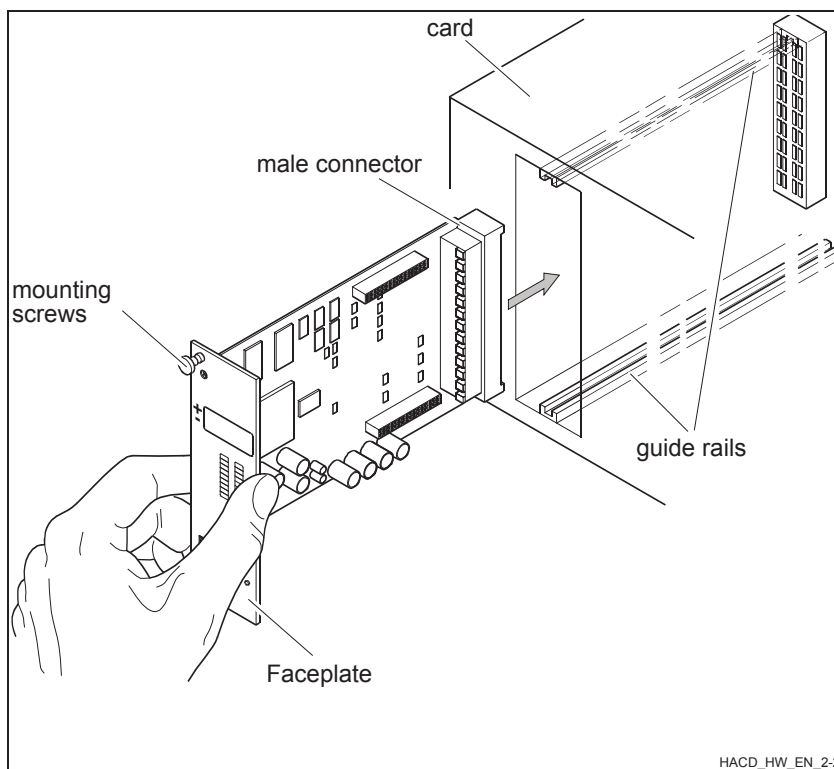

Fig. 2 Installing the controller card

- Tighten the two mounting screws on the front panel.
- ✓ The card is now installed correctly.

2.5 Edge Connector Terminals and Pin Assignments

The edge connector is a 64-pin, Type G (DIN 41612).

The pin assignments for the edge connector are not fully downward compatible with older amplifier products.

Differences in pin assignments have been implemented such that damage is prevented if an old controller card is replaced by an HACD controller card.

Pin assignment tables:

Row d	Pin	Description	Type
	2	DI 1	Discrete input
	4	DI 2	Discrete input
	6	DI 3	Discrete input
	8	DI 4	Discrete input
	10	DI 5	Discrete input
	12	DI 6	Discrete input
	14	DI 7	Discrete input
	16	DI 8	Discrete input
	18	DI 9	Enable
	20	DO 1	Discrete output
	22	OK	Ready
	24	Data +	Local CAN Bus Input/Output
	26	DO 2	Discrete output
	28	Data –	Local CAN Bus Input/Output
	30	AO 1	Analog output
	32	AO 2	Analog output

Tab. 1 Pin assignment of edge connector Row d

2 Installing the HACD

Pin	Description	Type
2	AI3+	Differential input
4	AI3-	Differential input
6	AI2+	Differential input
8	AI2-	Differential input
10	AI1+	Differential input
12	AI1-	Differential input
14	AI4+	Differential input
16	AI4-	Differential input
18	AI5+	Differential input
20	AI5-	Differential input
22	AI6+	Differential input
24	AI6-	Differential input (+)
26	AO3	Analog Output
28	AGND	Analog GND
30	REF-	Reference voltage -10V
32	REF+	Reference voltage +10V

Tab. 2 Pin assignment of edge connector Row b

Row z	Pin	Description	Type
	2	MA+	Solenoid a +
	4	MA-	Solenoid a -
	6	MB+	Solenoid b +
	8	MB -	Solenoid b -
	10	Shield	Shield
	12	L1O-	LVDT valve pin 2
	14	L1I-	LVDT valve pin 4
	16	L1I+	LVDT valve pin 3
	18	L1O+	LVDT valve pin 1
	20	Ground	System ground
	22	DO 3	Discrete output
	24	DO 4	Discrete output
	26	DO 5	Discrete output
	28	DO 6	Discrete output
	30	U _B	Supply voltage
	32	LO	Supply GND

Tab. 3 Pin assignment of edge connector Row z

2 Installing the HACD

Row f	Pin	Description	Type
	2	DO 7	Discrete output
	4	SSI Clk +	Clock output SSI encoder
	6	SSI Clk -	Clock output SSI encoder
	8	SSI Data+ / INC Ua1	Data input SSI encoder
	10	SSI Data - / INC /Ua1	Data input SSI encoder
	12	Ua2	Data input Incremental encoder
	14	/Ua2	Data input Incremental encoder
	16	Ua0	Data input Incremental encoder
	18	/Ua0	Data input Incremental encoder
	20	L2O-	n. c.
	22	L2I-	n. c.
	24	L2I+	n. c.
	26	L2O+	n. c.
	28	GND_CAN	CAN Bus reference
	30	CANL	CAN Bus In-/Output
	32	CANH	CAN Bus In-/Output

Tab. 4 Pin assignment of edge connector Row f

2.6 Installation Local Bus

The local bus is used to connect the individual amplifier cards of the HACD family. Data can be sent from one HACD to another or Bodac can use the local bus to communicate with any card on the bus without physically changing the connection.

Up to 32 cards can be connected. Each amplifier must be assigned a clear bus address.

The connection is established using a CAN protocol with a baud rate of 250kbit. The maximum length of the most distant amplifier cards must not exceed 280m. Moreover, the maximum length of the branch lines of 1 m must be observed.

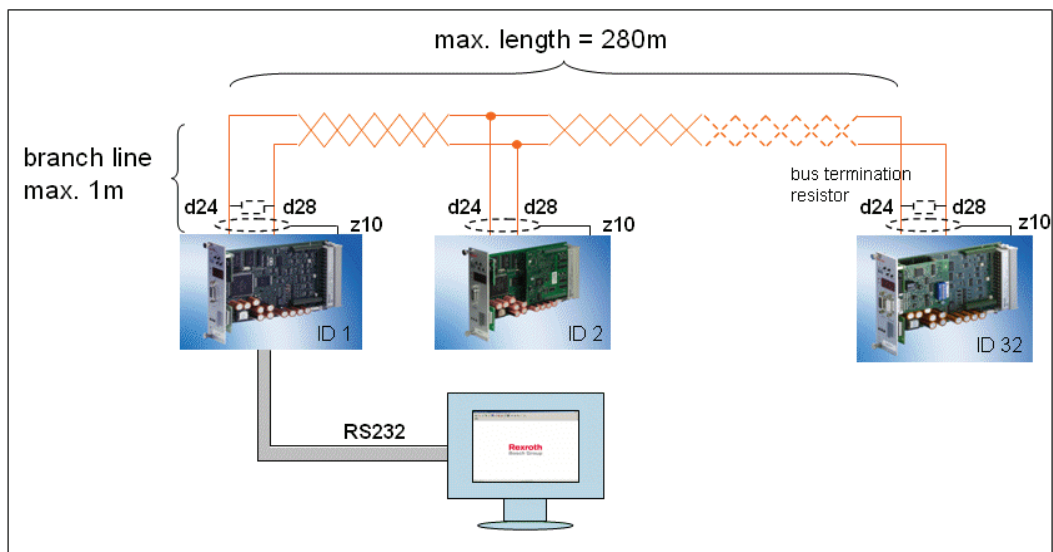

Fig. 3 Schematic structure of "Local Bus"



Data is to be transmitted via a shielded twisted-pair cable.

Two bus terminating resistors of 120 Ohm are required.



Using Local Bus to send data from one HACD to another takes priority over communicating with any other card via Bodac.

3 Startup of the HACD Controller Card

3 Startup of the HACD Controller Card

3.1 Preparing for Use

The startup procedure for the HACD controller card depends on a variety of factors that are determined by the individual application. For this reason, only the basic startup steps are described in this manual.

Preparing the controller card for use:

- Carefully check cabling.
- Apply power to the HACD controller card.

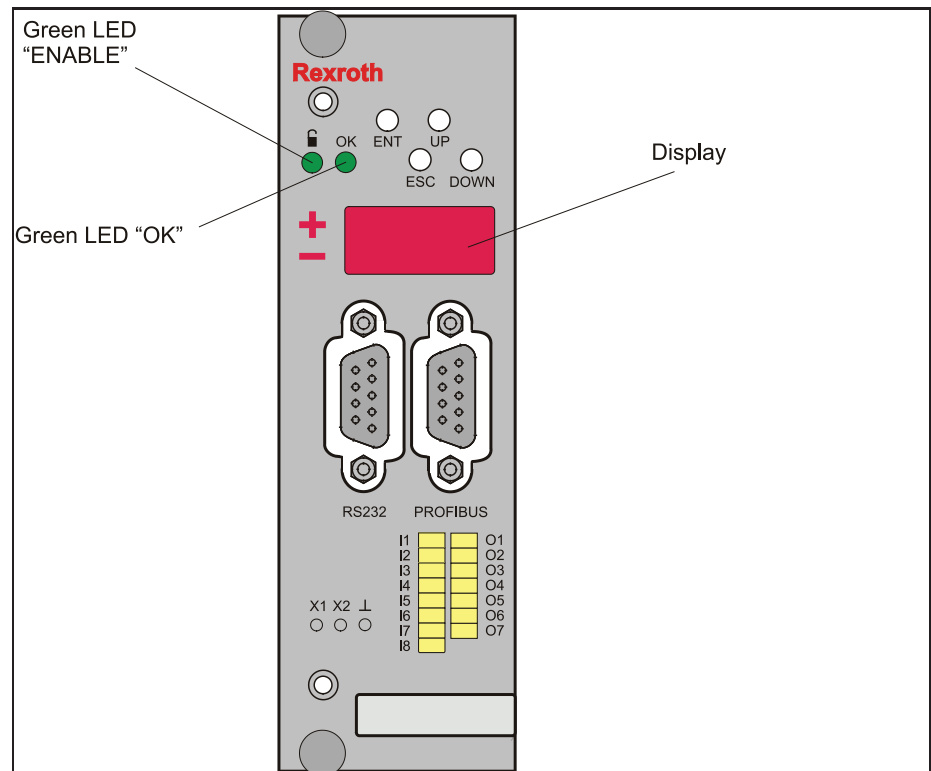

Fig. 4 Front panel of the HACD Controller Card

- ✓ The controller card performs an internal function test.
- ✓ The display on the controller card shows the manufacturer name and version number in scrolling text (when powered up)

3.2 Installing BODAC software

BODAC software (ordering code SYS-HACD-BODAC-01) can download via Internet. This software is used for initial startup and as a convenient configuration and monitoring tool for the controller card. BODAC can be used to configure the settings and parameters for optimal operation of the HACD controller card. The connected HACD card configures the function, menus and program windows in BODAC. This makes using the software easy.

Installation Requirements

Hardware 100% IBM compatible PC with the following minimum requirements:

- 200 MHz Pentium processor (or equivalent)
- 32 MB working memory (RAM)
- VGA graphics card, minimum resolution: 800x600 pixels
- Hard drive with minimum 2 MB available space
- CD-ROM drive
- Mouse
- Available serial port
- freie serielle Schnittstelle

Software ■ Operating system: Windows™ 2000 / XP.

If the hardware/software requirements are met, you can install BODAC as described in the next section.

BODAC Setup

To start the installation of BODAC, execute the "Setup.exe" file.

Installing BODAC software:

- Insert the CD-ROM and locate the file "Setup.exe".
- Double-click on "Setup.exe".
- ✓ The setup program will load and display a start screen.
- To run Setup, follow the instructions on the screen.
- ✓ BODAC software will then be installed.

3 Startup of the HACD Controller Card

3.3 Initial startup with BODAC

After installing the HACD controller card in a rack, as described in section 2.4, "Installing the card", and all initial steps have been completed properly, the card startup is ready.

Before proceeding with the following steps, be sure that the following requirements have been met:

- Serial interface cable is available
- A serial port on the PC is available
- BODAC software is installed.

Proceed with the initial startup:

- Connect serial cable (S/N 0776897) to the connector on the HACD card.
- Plug serial cable into the serial port (COM) on the PC.
- ✓ The HDAC card and PC are now connected.
- Start the BODAC software.
- ✓ Perform the software-side startup as described in the "Starting up the HACD Control Card and Operation of the BODAC Software" document.

4 HACD Operation

4.1 Display/Input Keys and Connectors on the Front Panel

You can use the display, input keys and connectors on the front panel of the HACD to check parameters and settings, attach diagnostic instruments and connect the card to a PC.

The following illustration shows an overview of the display, input keys and connectors on the front panel.

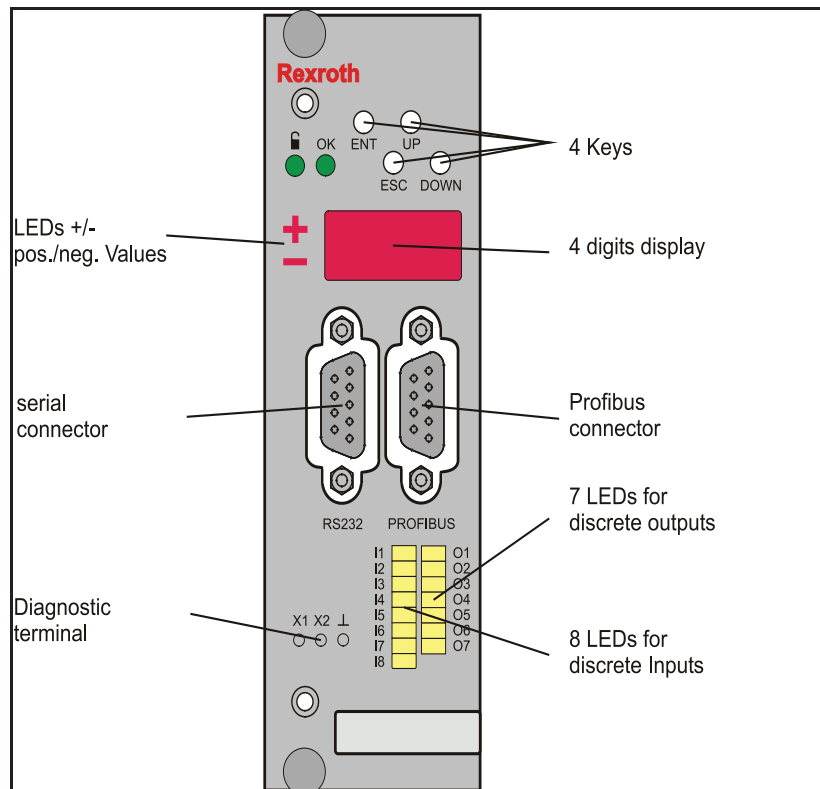

Fig. 5 Display, input keys and connectors on the control card

Display The display is four characters in length. Messages that exceed four characters are displayed as a scrolling display.

When parameters are displayed, the negative or positive sign is indicated by the “+” and “-“ LEDs.

LEDs for Discrete I/O The input LEDs indicate the state of the discrete input signals. The output LEDs show the state of discrete outputs from the controller card. When a signal is present on a discrete I/O, the associated LED will illuminate.

4 HACD Operation

Serial Port The serial port on the front panel is configured as a standard RS-232 port using a 9-pin D-Sub female connector. A standard 9 pin serial data cable is used to connect the serial port to a PC.

Profibus Port (optional) The Profibus DP V0 interface on the faceplate is a 9-pin D-Sub connector as described in the Profibus norm (EN 50170 Part 2). It connects the HACD card with a Profibus DP master. The connector is only available on HACD cards with optional Profibus.

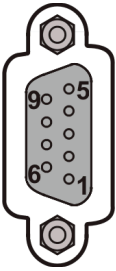
	Pin	Description
	3	RxD/TxD-P (B-Line)
	5	DGND
	6	VP (5V)
	8	RxD/TxD-N (A-Line)

The address setting is done via a DIL switch on the Profibus daughterboard of the HACD before the start up. Allowed values are between 1 and 126. Typically the DP master will have the address 0 to 2. Therefore it is advisable to choose an address higher than 2 for the HACD. Below is an example for the setting of the address 40:

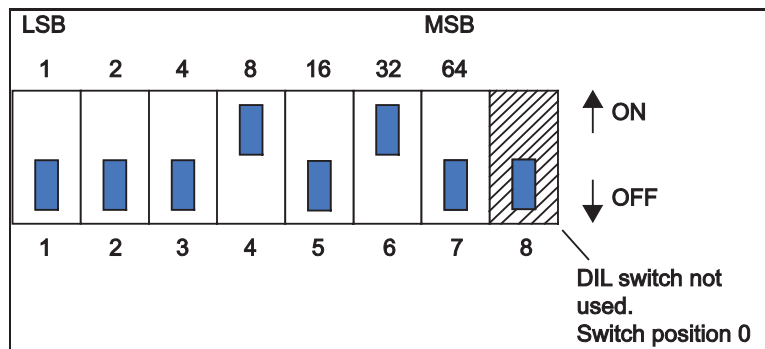

 The address will only be read during the card powers up. A change of the address will be done consequently only after a power reset of the card.

 When you distribute the address you have to take care that each Profibus station has its own explicit and once-only address.

For further information about the handling of Profibus parameters with the HACD see the documentation "RD 30 143-01-Z" (part of the BODAC package).

Buttons Four buttons are located on the front panel of the card. The functions of these buttons are described in detail in section 4.4, "Performing operations".

4.2 Diagnostics Test Jacks

The diagnostic test jacks on the front panel of the card can be used to connect external test instruments. Two analog voltage signals are available to perform measurements.

4 HACD Operation

4.3 Menu Tree for Setup and Parameters

The following contains an overview of the menus that can be selected using the buttons on the HACD controller card. Shown are the parameters and settings that are available

An overview of the items listed below are shown on the following pages:

- Menu tree "Parameter Part 1"
- Menu tree "Parameter Part 2"
- Menu tree "Parameter Part 3"
- Menu tree "Setup"
- Menu tree "Valve Menu"
- Menu tree "Analog I/O Part 1"
- Menu tree "Analog I/O Part 2"
- Menu tree "Digital I/O"
- Menu tree "SSI Configuration"
- Menu tree "Test Jacks Part 1"
- Menu tree "Test Jacks Part 2"
- Menu tree "Faults"

For a detailed description of the settings and parameters, please refer to document: "Starting up the HACD Control Card and Operation of BODAC Software".

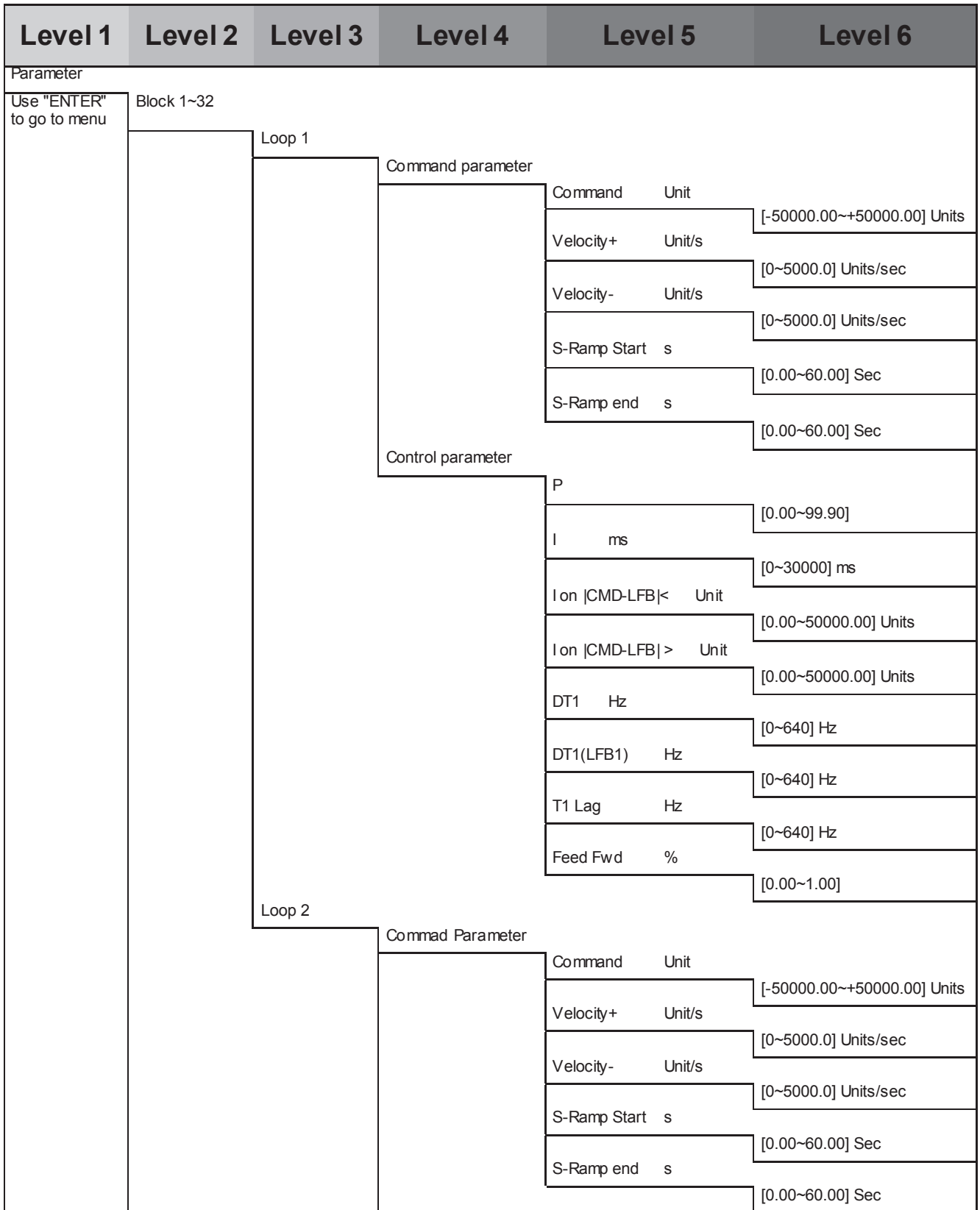

Fig. 6 Menu tree "Parameter Part 1"

4 HACD Operation

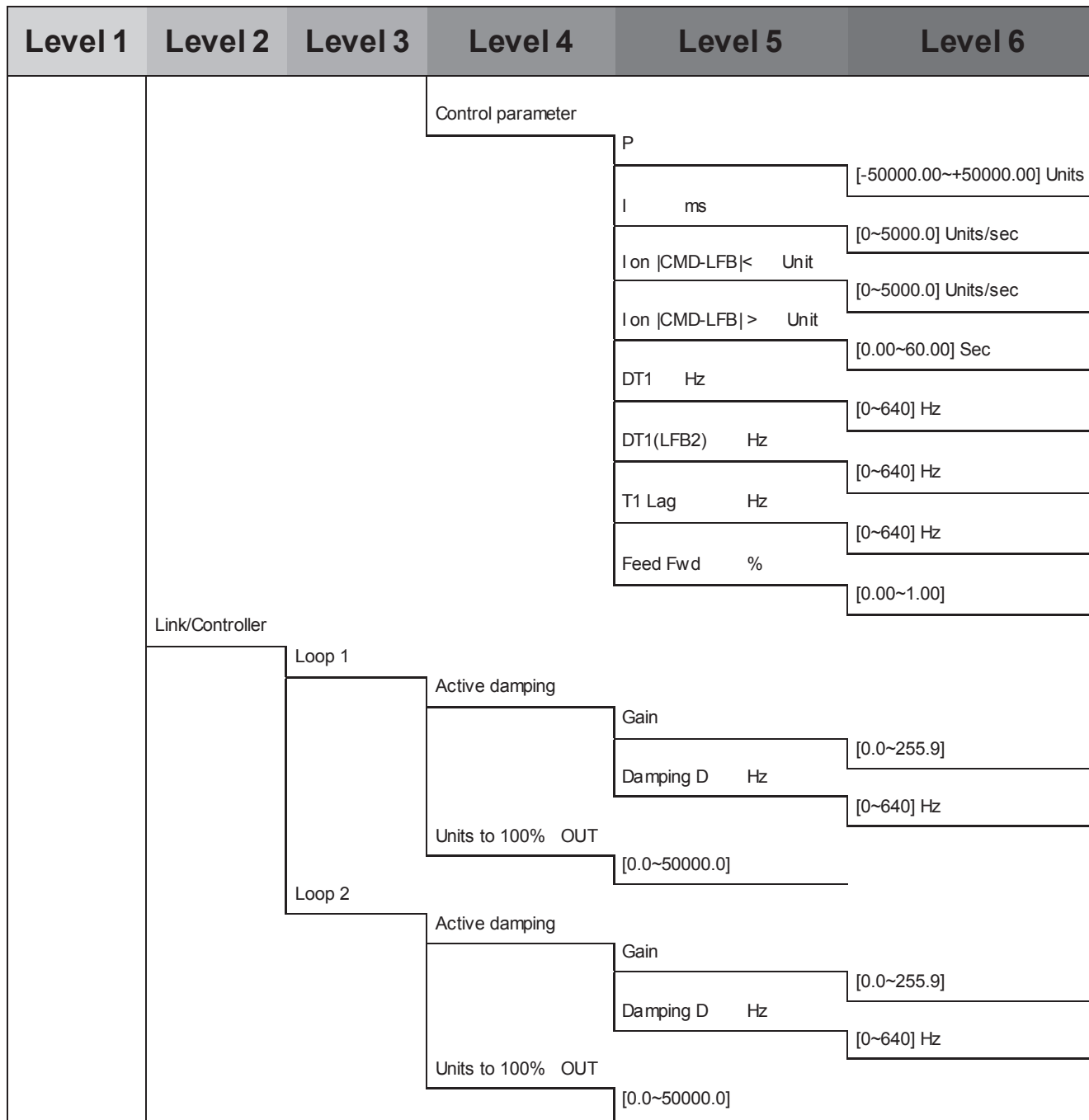

Fig. 7 Menu tree "Parameter Part 2"

Level 1	Level 2	Level 3	Level 4	Level 5	Level 6
	Output	Gain+			
		Gain-	[-10.00~+10.00]		
		Offset %	[-10.00~+10.00]		
		Overlap	[-100.00~+100.00]		
		Step+ %		[0.00~+100.00]	
		Step- %		[0.00~+100.00]	
		Deadband %		[0.00~+100.00]	
		Residual			
		Residual+ %		[0.0~+100.0]	
		Residual- %		[0.0~+100.0]	
		Accuracy window %		[0.0~+100.0]	
		Limit+ %		[0.0~+100.0]	
		Limit- %		[0.0~+100.0]	
	Constants	CON 1	[-50000.00~+50000.00] Units		
		CON 2	[-50000.00~+50000.00] Units		
		CON 3	[-50000.00~+50000.00] Units		
		CON 4	[-50000.00~+50000.00] Units		
		CON 5	[-50000.00~+50000.00] Units		
		CON 6	[-50000.00~+50000.00] Units		
		CON 7	[-50000.00~+50000.00] Units		
		CON 8	[-50000.00~+50000.00] Units		
	Configure *	Zeropoint valve %			[-12.0~+12.0]

Fig. 8 Menu tree "Parameter Part 3"

4 HACD Operation

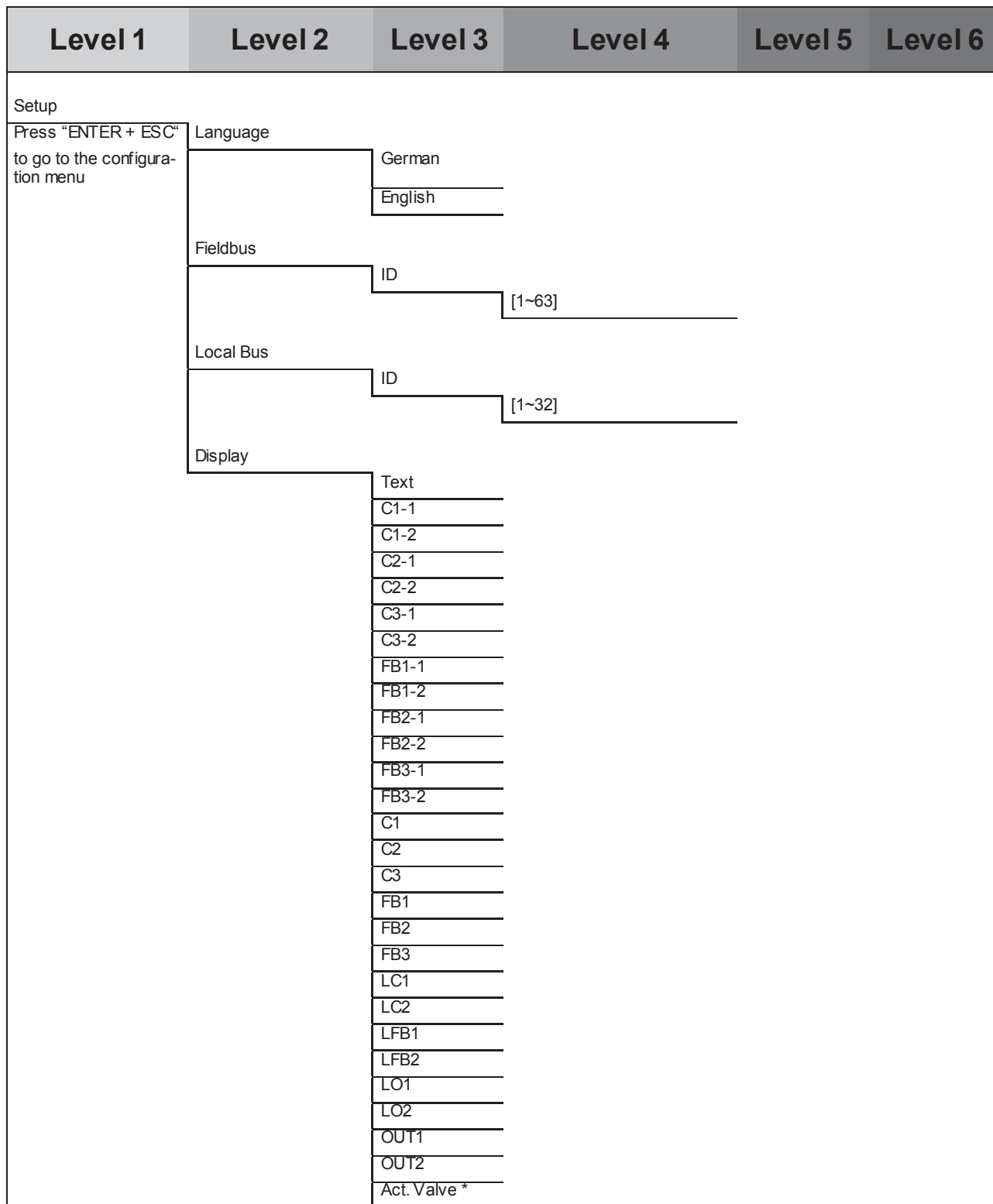

Fig. 9 Menu tree "Setup"

* only for VT-HACD-1-1x/v0/1-P-1



There has to be an obligatory reinitialization of the controller card after changing a bus ID. Toggle the card when the changes are written successfully to the memory.

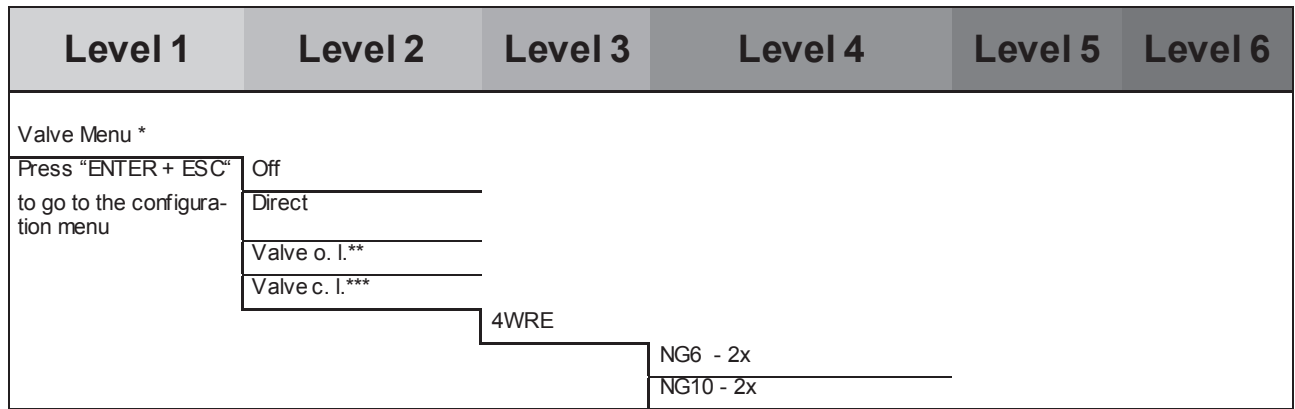

Fig. 10 Menu tree "Valve Menu"

* only for VT-HACD-1-1x/v0/1-P-1

** only for daughterboard TSPD

*** only for daughterboard TRPD

4 HACD Operation

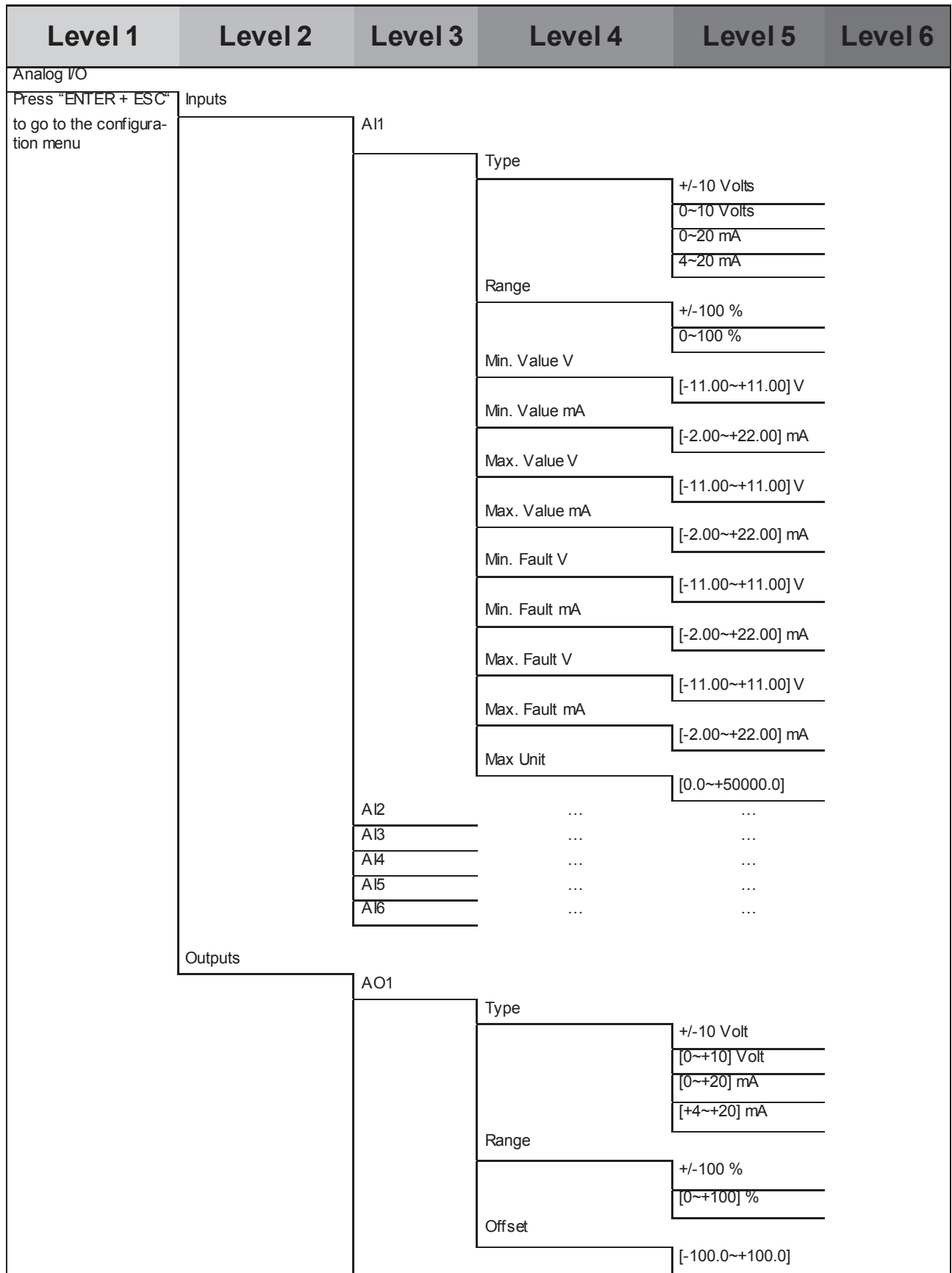

Fig. 11 Menu tree "Analog I/O Part 1"

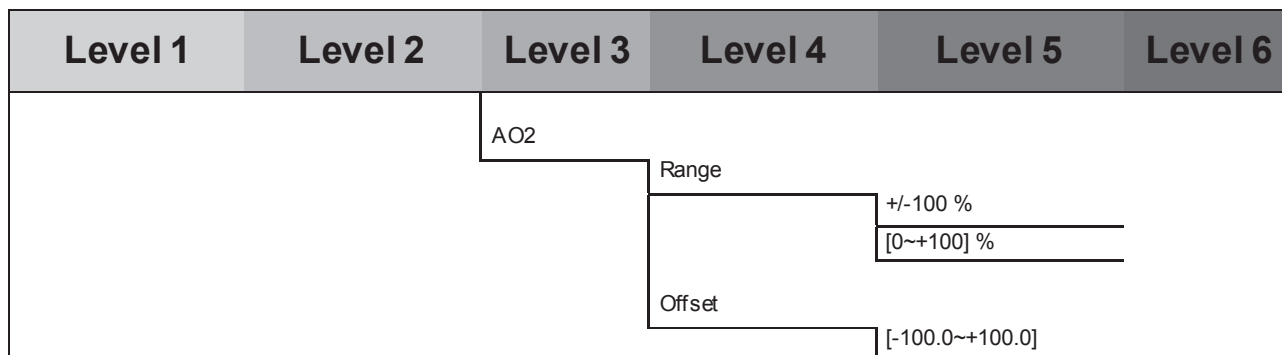

Fig. 12 Menu tree "Analog I/O Part 2"

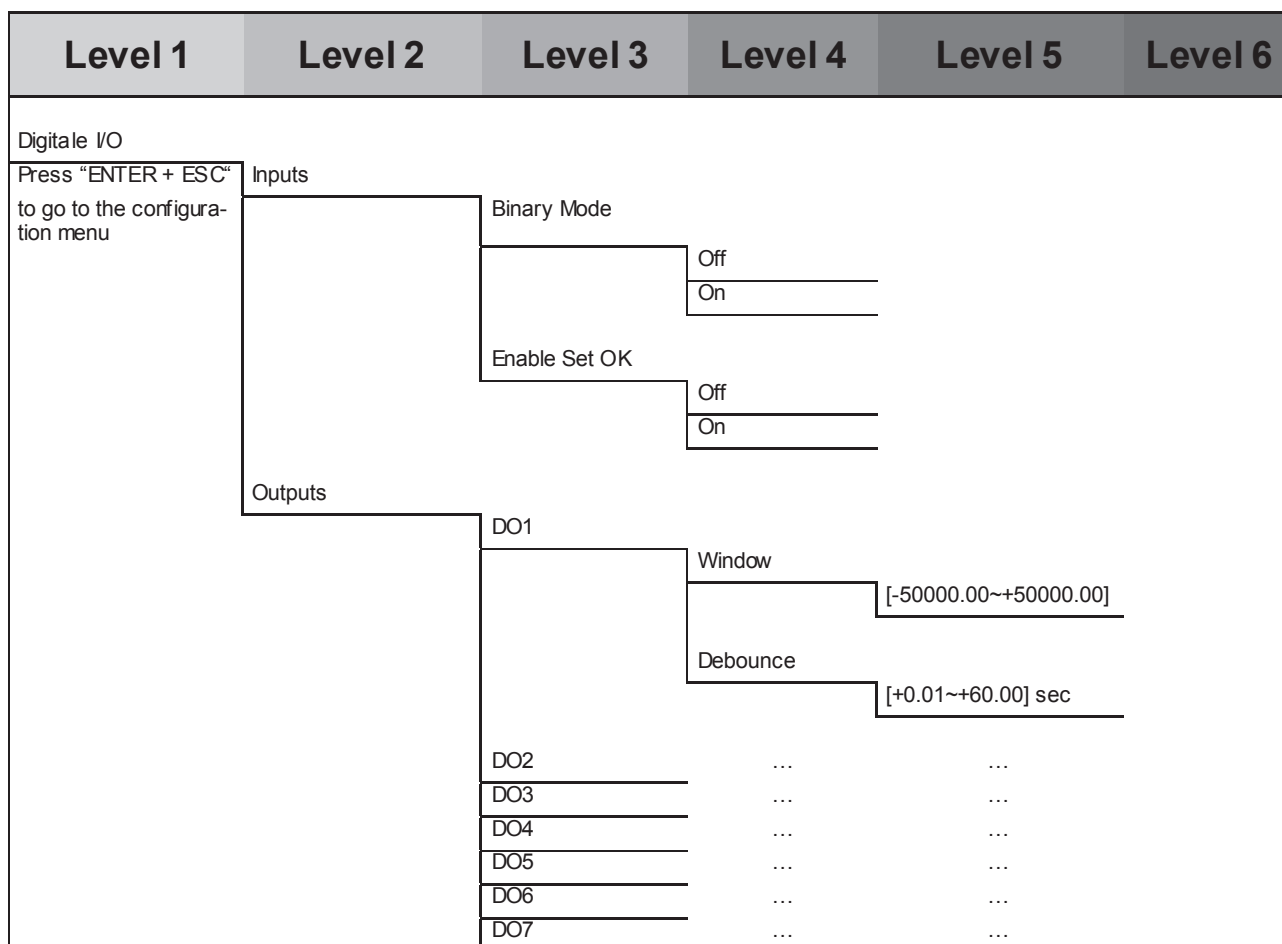

Fig. 13 Menu tree "Digital I/O"

4 HACD Operation

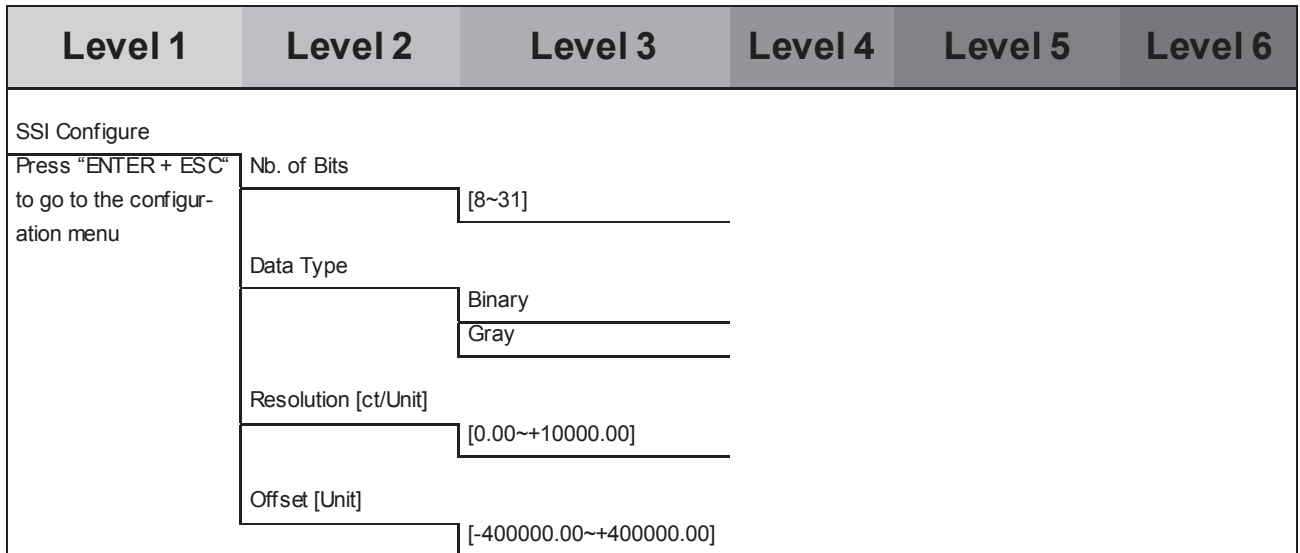

Fig. 14 Menu tree "SSI Configuration"

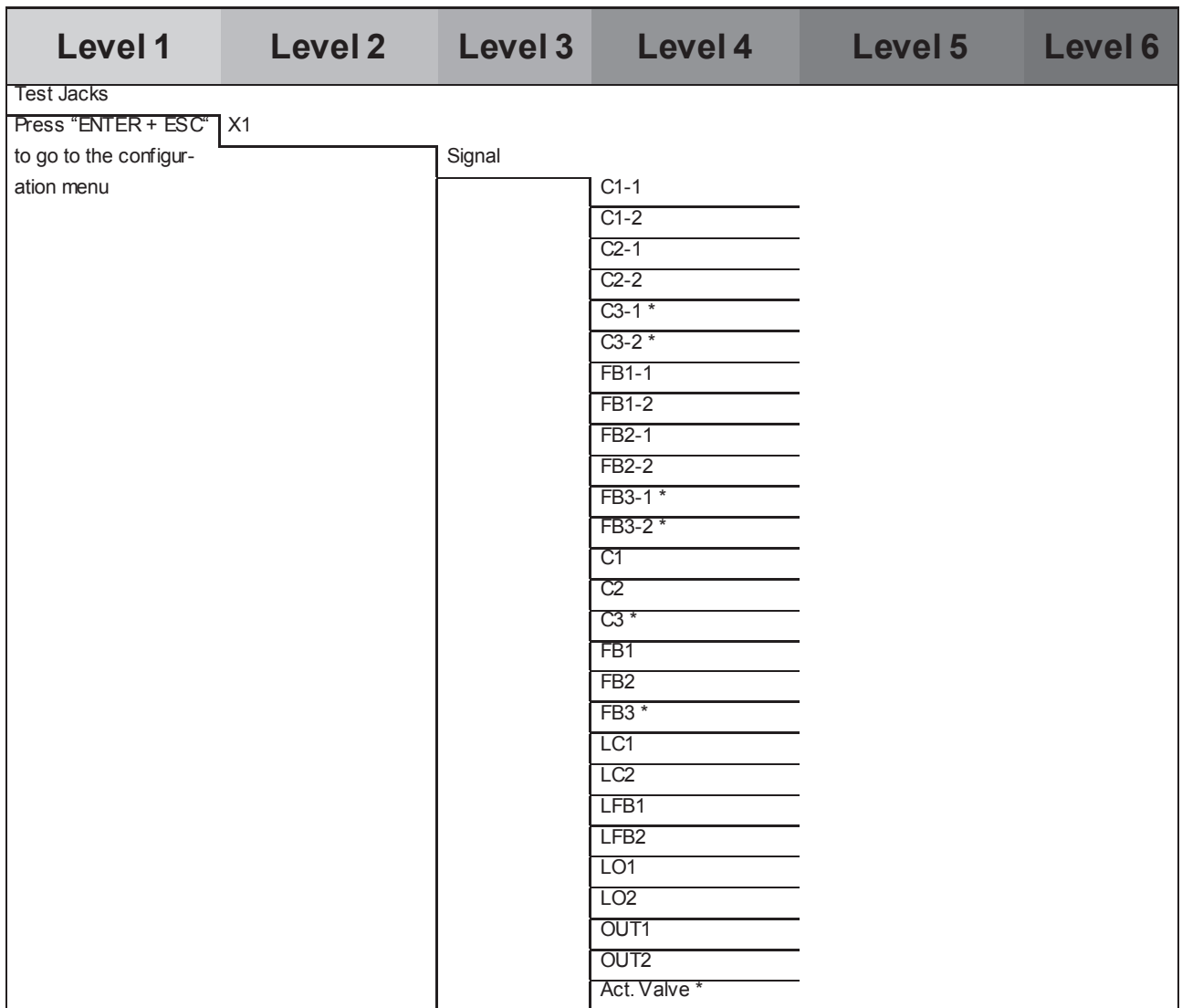

Fig. 15 Menu tree "Test Jacks Part 1"

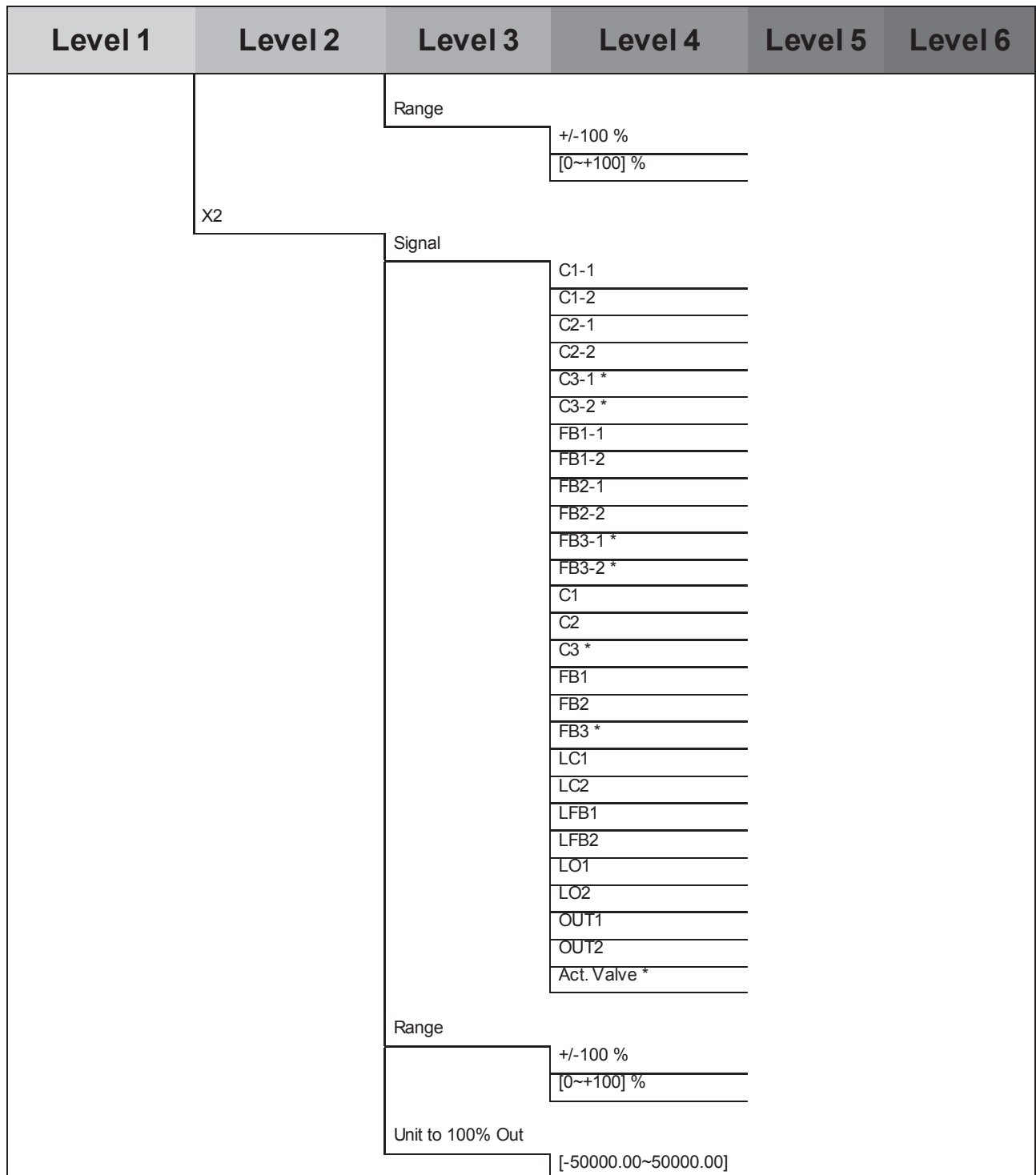

Fig. 16 Menu tree "Test Jacks Part 2"

4 HACD Operation

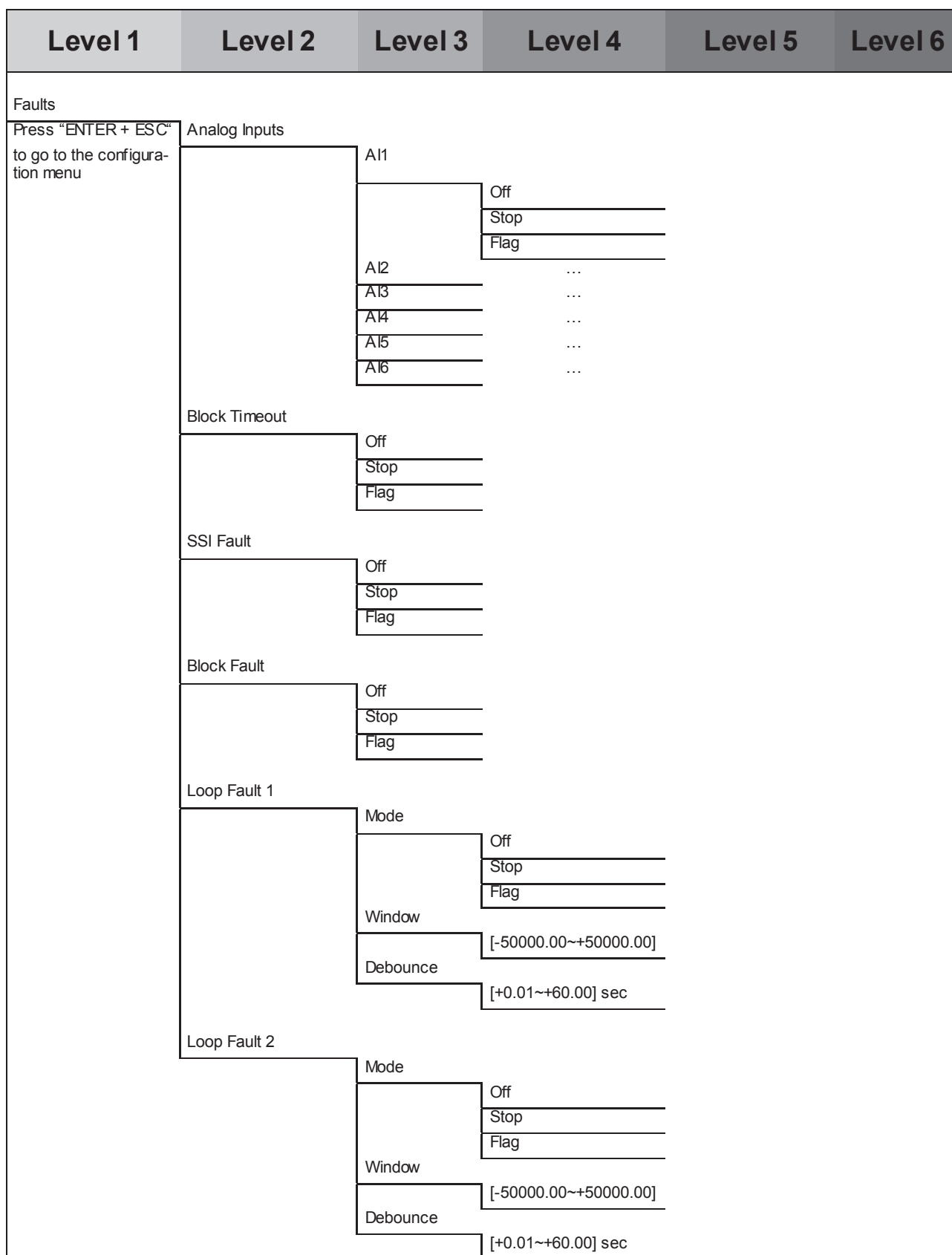

Fig. 17 Menu tree "Faults"

4.4 Display/Input Key Operations

All operations can be performed directly on the card using the "UP", "DOWN", "ENTER" and "ESCAPE" keys.



The keys are especially useful for quickly and easily checking, changing or correcting parameters and settings.

Always use BODAC software for the initial startup before placing the card in service.

Before making any changes to parameters or settings, familiarize yourself with the menu structure of the card. This can be found in section 4.3: "Menu tree for settings and parameters".

Key functions:

●
UP

Pressing the "UP" key moves in the upward direction, within the selected level, to available menu items. (for an overview, see section 4.3: "Menu tree for settings and parameters")

●
DOWN

Pressing the "DOWN" key moves in the downward direction, within the selected level, to available menu items (for an overview, see section 4.3: "Menu tree for settings and parameters").

●
ENTER

Change menu mode:

Press the "ENTER" key for 2 seconds or longer, to switch to configuration mode – "EDIT Parameters".

Change menu level:

Press the "ENTER" key to take you one level lower in the menu structure, or confirms an entered value.

Note: The entered value will be stored in memory by returning to level 0 (displaying the manufacturer's name).

The process of storing the data will take about a minute. During this time do not cut off the current supply of the card, otherwise your changes won't be saved in the memory.

●
ESCAPE
● + ●
ENTER ESCAPE

Pressing the "ESCAPE" key takes you one level higher in the menu structure.

Pressing the "ENTER" and "ESCAPE" keys simultaneously opens the configuration menu.

The configuration menu is structured in levels. The first level contains main categories, below which are additional sub-categories and settings. Depending on the entry selected, a main category may have up to 4 sub-levels.

4 HADC Operation

The following figure illustrates the menu level structure.

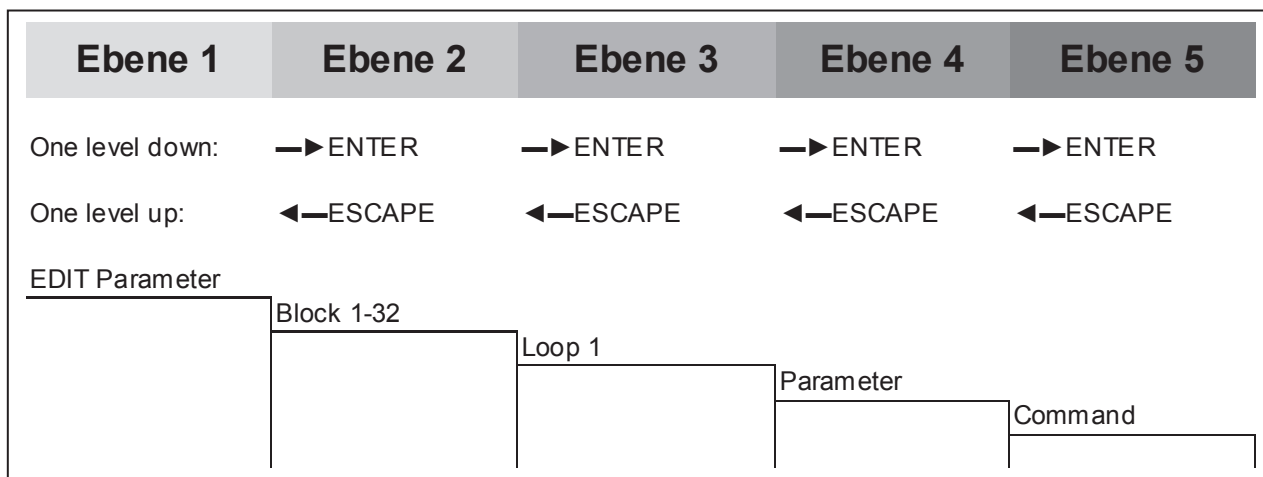

Fig. 18 Example of the menu levels in configuration mode

Changing from Run Mode to Configuration Mode – "EDIT Parameters":

The card must be in run mode.

The display will show scrolling text to display the manufacturer's name, the software version for the controller, or a custom configured text string.

- Press and hold "Enter" and "ESCAPE" simultaneously for at least 2 seconds (except when in "EDIT Parameter" mode, see above) until the display reads "Setup".
- ✓ The controller card is now in "EDIT Parameter" mode.

Changing from Run Mode to Configuration Mode:

The card must be in run mode.

The display will show scrolling text to display the manufacturer's name, the software version for the controller, or a custom configured text string.

- ✓ Press and hold "Enter" and "ESCAPE" simultaneously for at least 2 seconds (except when in "EDIT Parameter" mode, see above) until the display reads "Setup".

To exit Configuration Mode

As an example, the second level of the “Setup” menu is shown.

The display on the controller card shows the option “Sprache/Language”.

- Press “ESCAPE”.
- ✓ The display is scrolling “Setup”.
- Press “ESCAPE”.
- ✓ The display will show scrolling text to display the manufacturer’s name, the software version for the controller, or a custom configured text string



If while in Configuration Mode no entry is made within one minute, the controller card will automatically return to successively higher menu levels until Run Mode is reached.

The HACD Control Card is fully operational in Configuration Mode.

To change a parameter using the input keys.

As an example, the parameter "Max. Value" (see Fig. 11 Menu tree "Analog I/O Part 1"–Inputs – AI1) is shown. In this case, set the parameter to: "+10 Volts".

The card is now in Run Mode.

The display will show scrolling text to display the manufacturer’s name, the software version for the controller, or a custom configured text string.



WARNING!

When changing parameters using the input keys, hardware inputs are configured even when the discrete input “Enable” is active.

Caution:

Do not change any analog input from voltage to current or current to voltage when active.

Changing the analog inputs configuration may result in incorrectly interpreted values.

This can result in uncontrolled system operation and damage to the machine!!

- Press and hold the “Enter” and “ESCAPE” keys simultaneously for at least 2 seconds until the display reads “Setup”.
- ✓ The card is now in Configuration Mode.
- Press the “UP” or “DOWN” keys to select “Analog I/O”.
- Press “ENTER”.
- ✓ The card is now at the second level of the Configuration Menu, “Analog I/O” mode.

4 HACD Operation

- Press the "UP" or "DOWN" keys to select "Inputs".
- Press "ENTER".
- ✓ The menu entry Analog Input 1 ("AI1") is shown.
- Press "ENTER".
- Press the "UP" or "DOWN" keys to select "Max. Value".
- Press "ENTER".
- ✓ The current value is shown.
- Press "UP".

This creates a positive sign. Pressing „DOWN“ gives the value a negative sign.

- Press "UP" until "1" is displayed.
- Press "ENTER".
- Press "UP" until "0" is displayed.
- Press "ENTER".
- Press "UP" until "." is displayed.
- Press "ENTER".
- Press "UP" until "0" is displayed.
- Press "ENTER".
- Press "UP" until "0" is displayed.
- Press "ENTER".
- ✓ The parameter "Max. Value" 10 Volts is now entered and displayed.
- Exit the Configuration Menu by pressing "ESCAPE" five times.

To show setpoints/feedback values on the display run mode :

In this example, the signal "OUT1"(Fig. 9 Menu tree "Setup") will be used.

The card should be in Run Mode.

The display will show scrolling text to display the manufacturer's name, the software version for the controller, or a custom configured text string.

- Press and hold the "ENTER" and "ESCAPE" keys for at least 2 seconds until the display reads "Setup".
- ✓ The card is now in Configuration Mode.
- Press "ENTER".
- ✓ The card is at the second level of the Configuration Menu.
- Press the "UP" or "DOWN" keys to select "Display".
- Press "ENTER".
- ✓ Menu entry "Text" is displayed.
- ✓ Press the "UP" or "DOWN" keys to select "OUT1".
- Press "ENTER".
- ✓ The signal "OUT1" is displayed when the card returns to Run Mode.

5 Diagnostics

5 Diagnostics

5.1 Diagnostic Options on the HACD Controller Card

Diagnostics terminal



The diagnostic test jacks on the front panel of the HACD controller card (see section 4.2) provide two analog outputs with the following ratings:

- X1, 10 Volts for test equipment having $R_i \geq 100 \text{ k}\Omega$
- X2, 10 Volts for test equipment having $R_i < 100 \text{ k}\Omega$
- COM, ground

Test Jack "X1"

On test jack "X1" the value of analog output "AO3" is available. The signal is selected via the display menu (Fig. 11 Menu tree "Analog I/O Part 1").

Test Jack "X2"

Using the menu, the signal to be measured can be selected for analog output "AO3". A list of available signals is shown in (Fig. 12 Menu tree "Analog I/O Part 2").

Display indication when an error occurs

During initial startup, BODAC software can be used to select the action of the controller when an error occurs (available in the "Error" screen). If the controller card detects an error, which has been configured with BODAC software, the error will be displayed on the HACD controller card.



If the control card detects an error configured with BODAC software, respond as follows:

The display will flash "ERR" (Error) on the controller card!

Press "ENTER" to display the error message and clear the error.

The procedure for selecting the action desired when an error occurs can be found in the document "Starting up the HACD Control Card and Operation of the BODAC Software".

5.2 Diagnostics Using BODAC

The BODAC software includes additional detailed diagnostics capabilities.

The "Motion Data" screen and the "Status" screen display the current status of the controller card and of the connected sensors and devices.

Motion Data Screen The Motion Data screen displays the internal control signal values in the controller card. This provides a quick overview of the process status and values.

Status Screen The Status screen is used to display the status of the controller card. Each entry will display either "OK", "WARNING" or "ERROR" as a value.

For additional information on the Motion Data screen and the Status screen, refer to document "Starting up the HACD Control Card and Operation of the BODAC Software".

6 Detecting Errors

6 Detecting Errors

6.1 Error Messages

Error message	Description
+/- 10V voltage	Reference voltage +10V (b32) or reference voltage -10V (b30) outside allowable tolerances.
Supply voltage	Power supply (z30) less than U_b min.
DO1~DO8 short circuit	Short circuit on one or more of the 8 discrete outputs.
Checksum	Checksum error in program or data memory (Flash or EEprom)
Memory error	Error in working memory (RAM)
Version error	Versions of the individual program parts are not compatible (can occur only if updates to firmware were made)
Analog Input AI1	The signal on analog input AI1 is outside the valid signal range (adjustable, see Fig. 17 Menu tree "Faults").
Analog Input AI2	The signal on analog input AI2 is outside the valid signal range (adjustable, see Fig. 17 Menu tree "Faults").
Analog Input AI3	The signal on analog input AI3 is outside the valid signal range (adjustable, see Fig. 17 Menu tree "Faults").
Analog Input AI4	The signal on analog input AI4 is outside the valid signal range (adjustable, see Fig. 17 Menu tree "Faults").
Analog Input AI5	The signal on analog input AI5 is outside the valid signal range (adjustable, see Fig. 17 Menu tree "Faults").
Analog Input AI6	The signal on analog input AI6 is outside the valid signal range (adjustable, see Fig. 17 Menu tree "Faults").
Block Timeout	The block time value for a block has timed out, without another block being called.
SSI error	Cable fault on SSI encoder
Block error	Ambiguous block triggers
LC1 <> LFB1	A control difference between setpoint (LC1) and feedback (LFB1). The difference value (window) and time delay (delay) can be set in the controller card
LC2 <> LFB2	A control difference between setpoint (LC2) and feedback (LFB1). The difference value (window) and time delay (delay) can be set in the controller card

6.2 Changing fuses

The controller card is protected against overload by means of a fuse. The fuse is the following type:

- F / 4 A / 250 V



NOTE!

The fuse is defective and must be replaced!

The fuse has opened due to mechanical damage or a product defect.

In this case, replace the fuse with a new one of the type indicated above.

The fuse has opened due to external connections, IE: externally connected components or wiring connected to the controller card have faulted.

In such cases, diagnose and correct the problem that caused the fuse to open.

Only then replace the fuse with a new one.

Replacing the fuse on the HACD Control Card:

- Remove HACD controller card the card holder (reverse of the procedure described in section 2.4, GeneralCard Installation)
- Gently remove the fuse from the fuse holder (see Fig. 19).

6 Detecting Errors

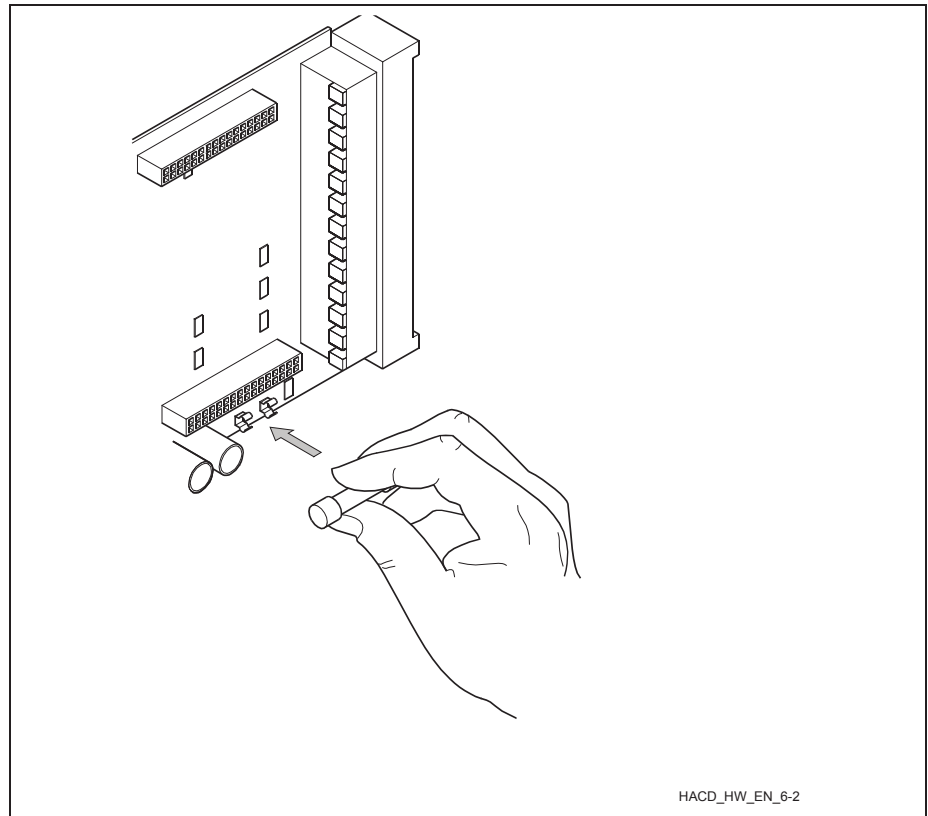

Fig. 19 Fuse on the HACD Controller Card

- Use a suitable test device to check the fuse. (continuity test)
- If the fuse is defective, replace it with the same type.
- Reinstall the HACD controller card and perform a functional test.

7 Index

Action symbol	6
Analog GND	14
Analog input	14
BODAC setup routine	19
BODAC software	19
CAN Bus in-/output	13
Change parameter	39
Characters	6
compatible	13
Configuration mode	37
Control card	
Installation	12
Diagnostics terminal	23, 40
Diagnostics using BODAC	41
Differential inputs	9
Digital input	13
Display	21
DOWN	35
Drives	
Electromechanical and electrohydraulic	5
EC Directive 89/392/EWG (Machine Directive)	8
Edge connector	13
EMC Regulations	8
ENTER	35
Error conditions	40
Error messages	42
ESCAPE	35
Front panel	12
Fuse	43
HACD	40
Initial startup	40
Installation	9
Installation requirements	19
Keys	35
Language	28
LED's for digital in-/outputs	21
Local Bus	17
Menu tree	
"Analog I/O Part 1"	30
"Parameter Part 1"	25
"Parameter Part 2"	26
"Parameter Part 3"	27
"Setup"	28
"Valve Menu"	29
"Digital I/O"	31
"Faults"	34
"SSI Configuration"	32
"Test Jacks Part 1"	32
"Test Jacks Part 2"	33
"Analog I/O Part 2"	31
Noise sources	9
Parameter changing	37
Password	28
Power cables	9
Reference voltage	14

7 Index

Result symbol.....	6
Run mode.....	36
Running text.....	36, 37, 39
Safety fuse.....	43
Safety requirements.....	5
Sensor lines.....	9
Serial port.....	22
Shield.....	10
Shielding.....	10
Supply GND.....	15
Supply voltage.....	15
Symbols.....	6
System ground.....	10
Transport.....	11
Troubleshooting.....	10
UP.....	35
Warning symbol	
Equipment damage.....	6
Hazard potential, electrical current.....	6
Hazard potential, general.....	6

Bosch Rexroth AG
Hydraulics
Zum Eisengießer 1
97816 Lohr, Germany
info@boschrexroth.de
www.boschrexroth.com

© This document, as well as the data, specifications and other information set forth in it, are the exclusive property of Bosch Rexroth AG. It may not be reproduced or given to third parties without its consent.

The data specified above only serve to describe the product. No statements concerning a certain condition or suitability for a certain application can be derived from our information. The information given does not release the user from the obligation of own judgment and verification. It must be remembered that our products are subject to a natural process of wear and aging.

Printed in Germany
RE 30143-B/09.13
Replaces: 08.07