

Reliability and safety

Programmable Electronic Control Unit EBH-08 Series



1800-OILSOL
1800-645765

<https://oilsolutions.com.au/>

sales@oilsolutions.com.au

Electronic solutions for mobile applications

Flexible hardware and software architecture

Main features

- Single/Dual microcontroller
- Flexible hardware configuration to fulfil the required functions and to optimize the product cost.
- Double opto isolated can bus, available.
- RS232 interface for standard applications, available.
- Sealed with resin for maximum protection
- C/C++ programmable.
- Suitable for MATLAB automatic code generation.
- Up to HW category 2
- MTTFd = 72 y

Applications

- Material handling
- Agriculture
- Construction Equipment
- Industrial
- Forestry

Technical Data

Main microcontroller	32 bit RISC 80 MHz
Safety microcontroller	16 bit F ² MC 32 MHz
Memory	2KB EEPROM
Supply	8-30 V dc
Operative temperature range	-40 to +85° C
Protection class	IP67
Dimensions (DxHxW)	142x28x127 mm
Connector	48 Pin JST S48B-ZROK

INPUTS:

4x Digital NPN-PNP

10x Analog

2x Frequency (NPN sensors, up to 5 kHz)

OUTPUTS:

1x Vsupply 5V@300mA@85° C → 500mA@70° C

8x PWMi up to 3A, 1% accuracy, up to 300Hz

2x LSD 200 mA (optional)

COMs:

2x CAN BUS high speed (opto isolation as options)

1x RS232 (optional)

Dimensions

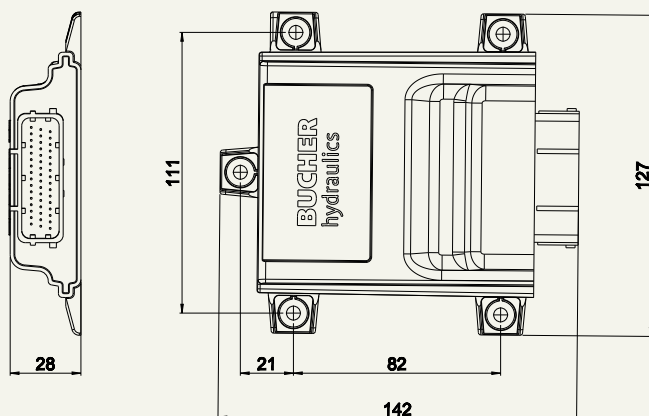
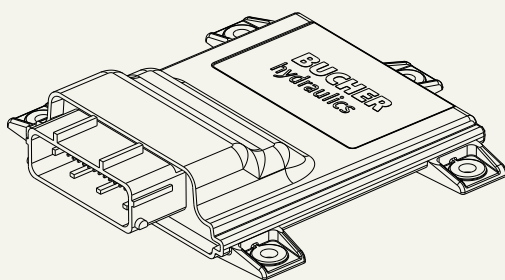

Reference schematic

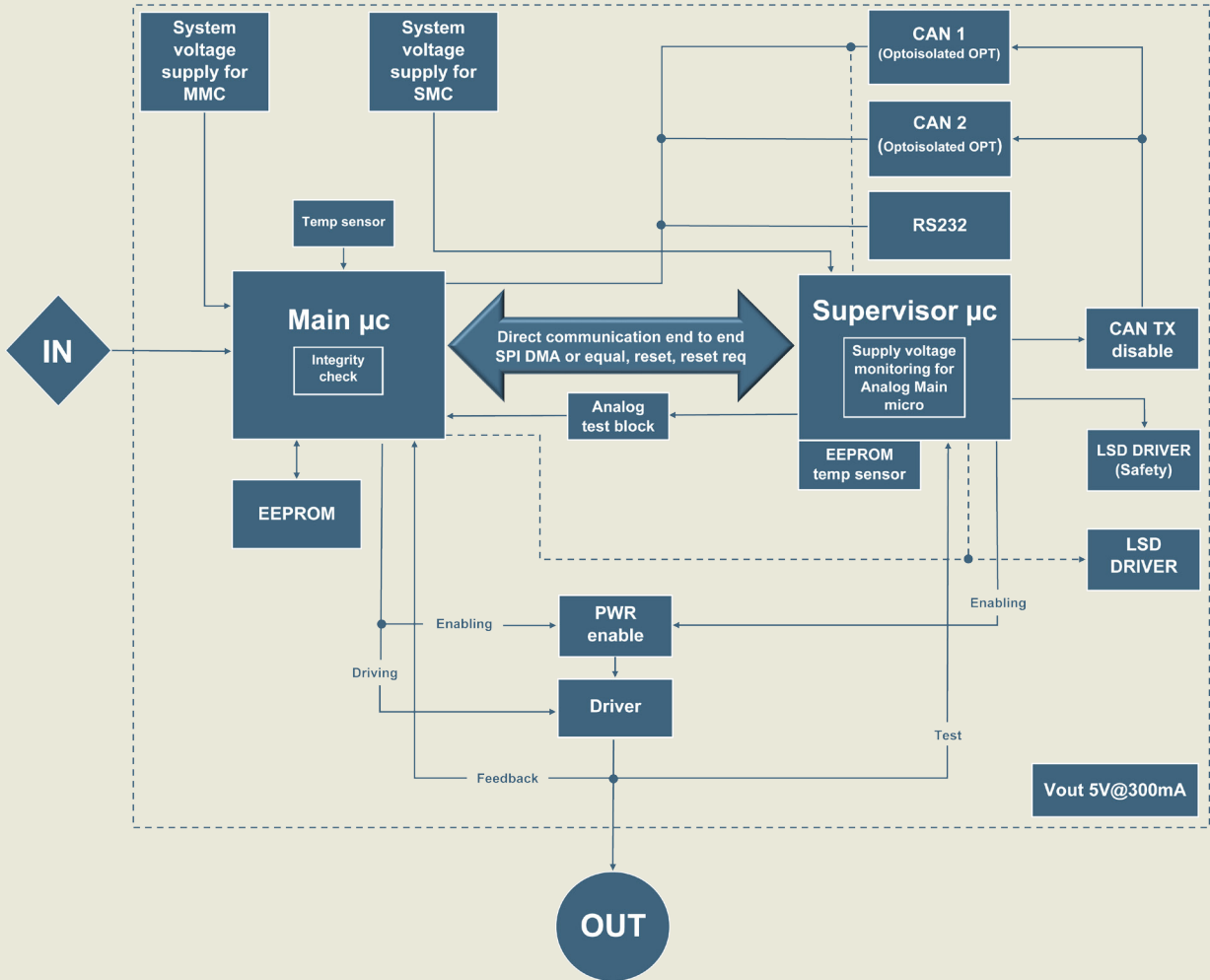

Application example: CAN BUS Application example: analog

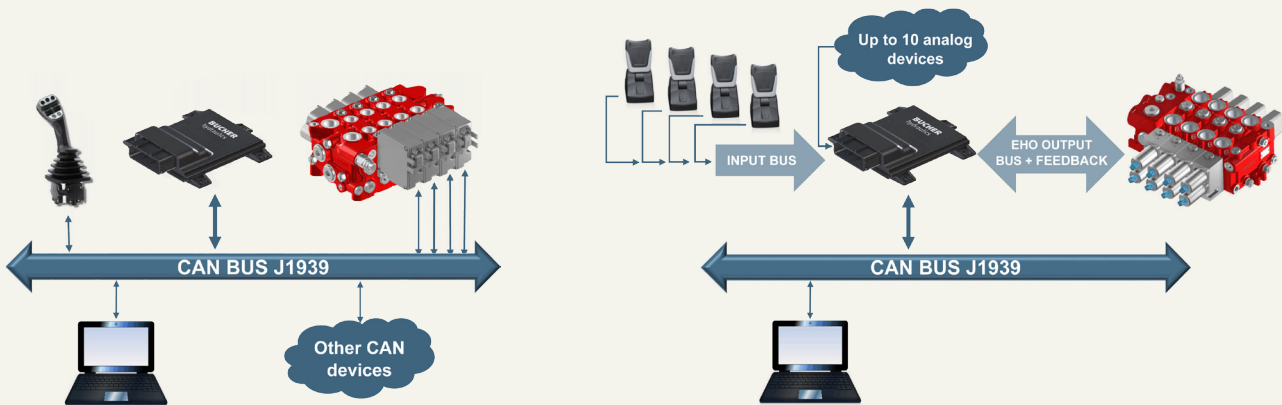

Application example: hybrid

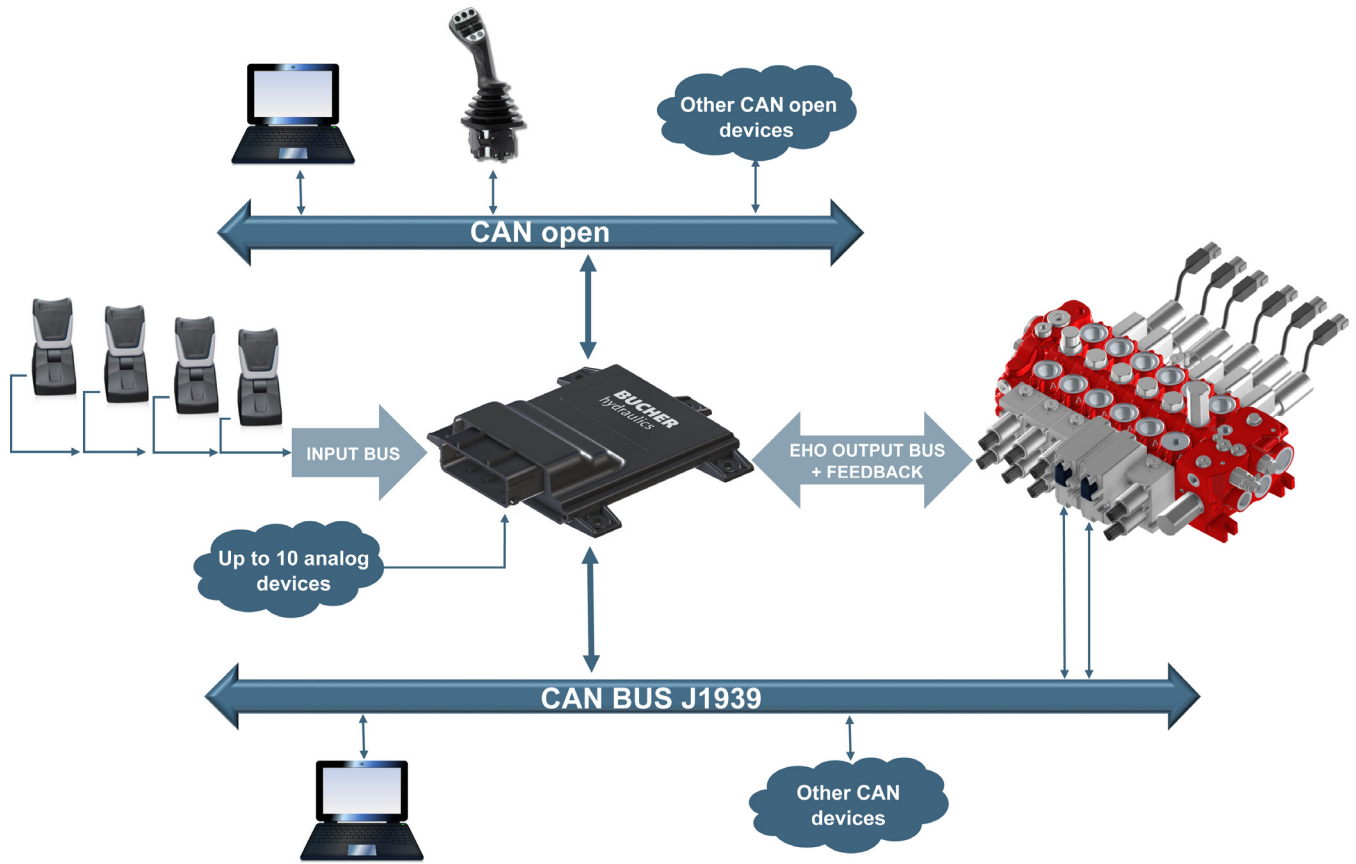

Applications



Smart Solutions. Superior Support.

For further information please do not hesitate to contact us.

Bucher Hydraulics S.p.A.

Via P. Colletta 5

IT-42124 Reggio Emilia

Phone: +39 0522 928411

Fax: +39 0522 513211

info.it@bucherhydraulics.com

www.bucherhydraulics.com