

Controller

ELSK 106



1800-OILSOL
1800-645765

<https://oilsolutions.com.au/>

sales@oilsolutions.com.au



Reference: 100-P-700070-E-01

Contents		Page
1	Overview Controller	5
2	General	7
2.1	Advantages	7
2.2	Description	7
2.4	Technical data	7
3	Controller ELSK 106-****	9
3.1	Description	9
3.2	Dimensions and connection diagram	9
3.3	Ordering code	9
4	ELSK 106-01***/11 control box	10
4.1	Description	10
4.2	Technical data	10
4.3	Functional description	10
4.4	Connection diagram	10
4.5	Block diagram	11
4.6	Ordering code	11
5	ELSK 106-02***/11 control box	12
5.1	Description	12
5.2	Technical data	12
5.3	Functional description	12
5.4	Connection diagram	12
5.5	Ordering code	12
6	ELSK 106-09*** control box	13
6.1	Description	13
6.2	Technical data	13
6.3	Functional description	13
6.4	Connection diagram	14
6.5	Ordering code	14
7	Controller ELSK 106-10***	15
7.1	Description	15
7.2	Technical data	15
7.3	Functional description	15
7.4	Connection diagram	16
7.5	Ordering code	16

8	ELSK 106-14*** control box	17
	8.1 Description	17
	8.3 Technical data	17
	8.4 Functional description	17
	8.5 Block diagram	18
	8.6 Ordering code	18
9	ELSK106-15*** control box	19
	9.1 Description	19
	9.3 Technical data	19
	9.4 Functional description	19
	9.5 Block diagram	20
	9.6 Ordering code	20
	9.7 Spare part	20
10	ELSK 106-16*** control box	21
	10.1 Description	21
	10.3 Technical data	21
	10.4 Functional description	21
	10.5 Block diagram	22
	10.6 Ordering code	22
11	Wiring loom	23
	11.1 Wiring loom EKAB100-	23
	11.2 Wiring loom EKAB101-	24
12	Accessories	25

1 Overview Controller

ELSK 106 compact amplifier	Description
	<p>Proportional amplifier module; front plate and indicator knob</p>
ELSK 106-01***/11 control box	Description
	<p>ABS-housing with magnetic clamp, M12 sleeve, rotary potentiometer, indicator knob; LED</p>
ELSK 106-02***/11 control box	Description
	<p>ABS-housing with magnetic clamp, M12 sleeve, rotary potentiometer, indicator knob, ON/OFF-switch, LED</p>
ELSK 106-09*** control box	Description
	<p>Aluminium housing shock resistant with 2 potentiometers, 3 toggle switches, 1 LED and a socket STAF 14</p>
ELSK 106-10*** control box	Description
	<p>Robust aluminium housing with 2 potentiometers, 3 toggle switches, 1 LED and a socket STAF 14</p>
ELSK 106-14*** control box	Description
	<p>Robust aluminium housing with 2 potentiometers, 3 toggle switches, 1 LED, 1 keylock (starter) and a socket STAF 14</p>

ELSK 106-15*** control box	Description
	<p>Robust aluminium housing with 2 potentiometers, 1 ON/OFF-switch, 3 toggle switches, 3 control LED's, 1 keylock (starter) and a socket STAF 14</p>
ELSK 106-16*** control box	Description
	<p>Robust aluminium housing with 3 potentiometers, green control-LED, ON/OFF-switch, 4 toggle switches for work light, spread symmetry, warning beacon and connector insert, and a socket STAF 14</p>

2 General



2.1 Advantages

- Solid-state electronics; no wear-prone contacts
- Stepless adjustment
- Ergonomic design
- Tough, heavy-duty housing

2.2 Description

The ELSK 106 compact amplifier is used to control the solenoid of a proportional hydraulic valve. The current compensation feature ensures that changes in the coil temperature or fluctuations in the supply voltage do not affect the coil current level. It is integrated in a U-profile and can be secured with one nut on, for example, an instrument panel. The front plate must be separately secured. The proportional amplifier requires a smoothed DC power supply in the range 12...30 V. The potentiometer is provided with an integral ON/OFF switch. The current at the power output varies

linearly with the knob rotation of the potentiometer. With the aid of two trimming potentiometers, both minimum and maximum current values can be set. The amplifier switches off automatically for the duration of any short circuit at the load terminals. Within the amplifier, a quenching diode is connected in parallel with the power output. This protects the output stage against switch-off spikes. The ESK 106 will be supplied in the tabulated housings with numerous options.

2.3 Application examples

- Agricultural and forestry equipment
 - Fertiliser spreader
 - Dung spreader
 - Fodder mix and cast wagon
- Construction machines
 - Road rollers
 - Ground drilling rigs
- Municipal equipment
 - Snow and ice cleaning equipment
 - Sweeper
- General
 - Speed and pressure control
 - Materials handling
 - Belt and spinner drive
 - Scraper floor drive

2.4 Technical data

Electrical characteristics	Unit	Description, value
Power supply (U_b)	V DC	12...30, smoothed. ripple < 10%
Minimum current (I_{min})	A	0,2...1,2
Maximum current (I_{max})	A	$I_{min} + (0,4...max. 2,5)$
Maximum output voltage	V	approx. (supply voltage -3,5)
Maximum permissible output current (I_{zul})	A	2,5
Dither frequency	Hz	Factory setting at 100 (triangular wave)
Protection class		IP53
Operating temperature	°C	-20...+50

Electrical characteristics	Unit	Description, value
Notable features		The power supply input is reverse-polarity protected The amplifier switches off automatically for the duration of excessive coil current (coil short circuit)
Weight		approx. 100 g
Cable length and section		For 1 mm ² section wire, max. cable length is 10 metres
Electromagnetic compatibility		- EN 14982 radiated emission - ISO 11452--2..--5 Immunity radiated electromagnetic energy - ISO/TR 10605 Immunity against discharge static electricity - ISO 7637--0..--2 Immunity against circuit disturbance; class D, A

Description	Ordering code
Technical dataGewichts-sheet ESKK 106 100-P-700008	Technical documentation with all relevant descriptions, data characteristic lines and measurements.

3 Controller ELSK 106-*****

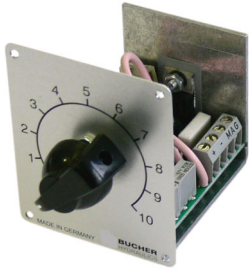

3.1 Description

The ELSK 106-***** unit is used to control a proportional solenoid. It consists of the ESSK 106-91*** card, fitted in a plastic enclosure. The enclosure is provided with a front plate with an ON/OFF switch, a green LED and a demand signal potentiometer with indicator knob.

The output current varies linearly with the angle of rotation of the demand signal potentiometer. The green LED lights as soon as the unit is switched on.

3.2 Dimensions and connection diagram

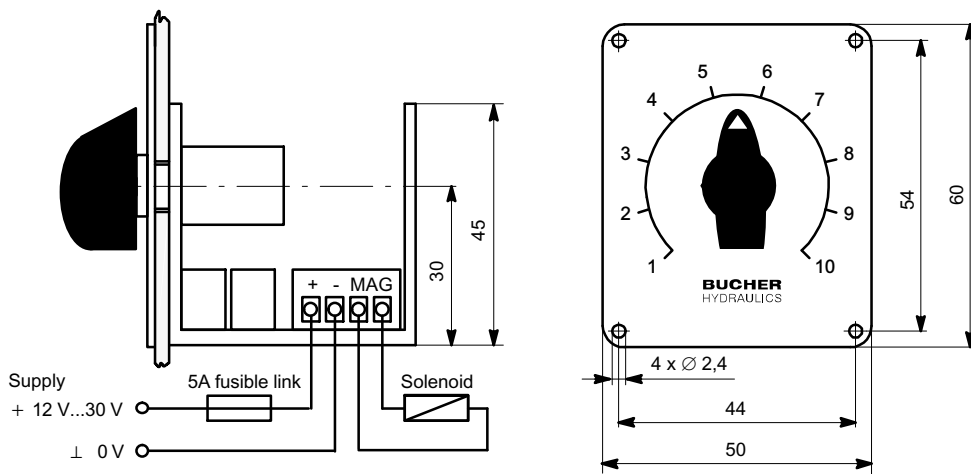

3.3 Ordering code

Description	Type	Ordering code
Controller with screw terminals	ELSK106-91***	100018790
Controller with screw terminals; potted	ELSK106-81***	100018791
Controller with screw terminals; potted; with ramp, 4 sec	ELSK106-81***/04	100026079
Controller with screw terminals; potted; with ramp, 2 sec	ELSK106-81***/02	100013454
Accessories see chapter 12		

4 ELSK 106-01***/11 control box



4.1 Description

The ELSK 106-01***/11 unit is used to control a proportional solenoid. The proportional solenoid is controlled by an integrated module ESKK 106-91***. The ABS-housing provides a front plate, with an ON/OFF switch, a green LED and a potentiometer with indicator knob. The potentiometer provides an indicator knob with ON/OFF-switch in zero position. The output current varies linearly with the rotating angle of the potentiometer. The green LED lights as soon as the ON/OFF-switch is turned on. Minimum and maximum current level are adjustable.

4.2 Technical data

General characteristics	Unit	Description, value
Dimensions	mm	82 x 80 x 65 (L x B x H)

4.3 Functional description

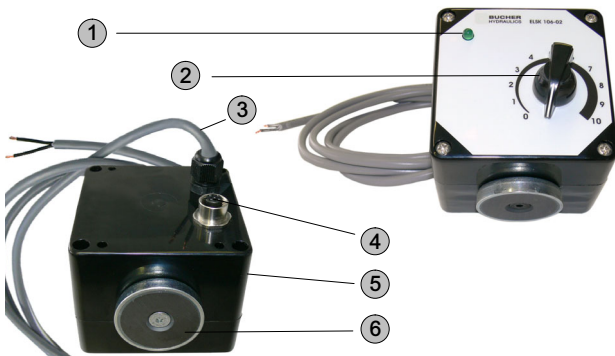

1	Control unit LED, input current
2	Rotary potentiometer with ON/OFF-switch
3	Power supply connection cable 1,5m, 2 x 1,5 mm ² , free cable ends
4	Output solenoid (4-pin M12 sleeve)
5	ABS-housing: 82 x 80 x 65
6	Magnetic clamp

4.4 Connection diagram

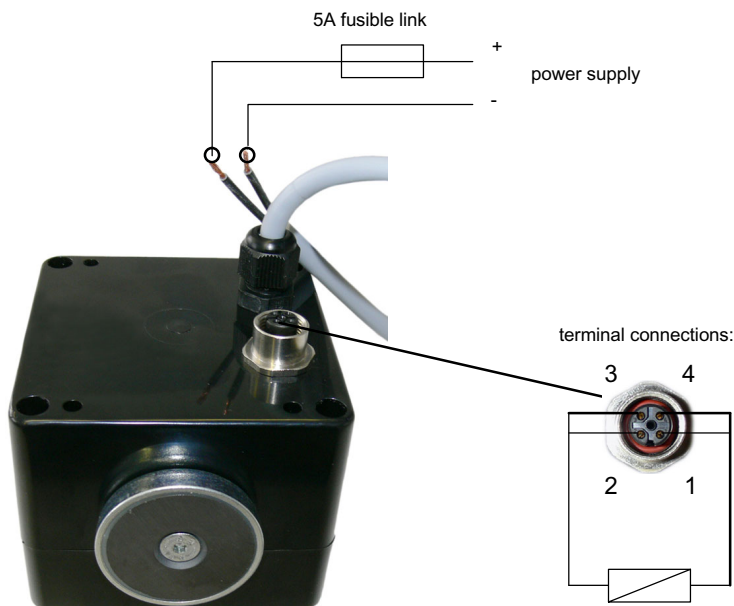

On the 4 pin connector the solenoid loads must be connected using both pins.

4.5 Block diagram

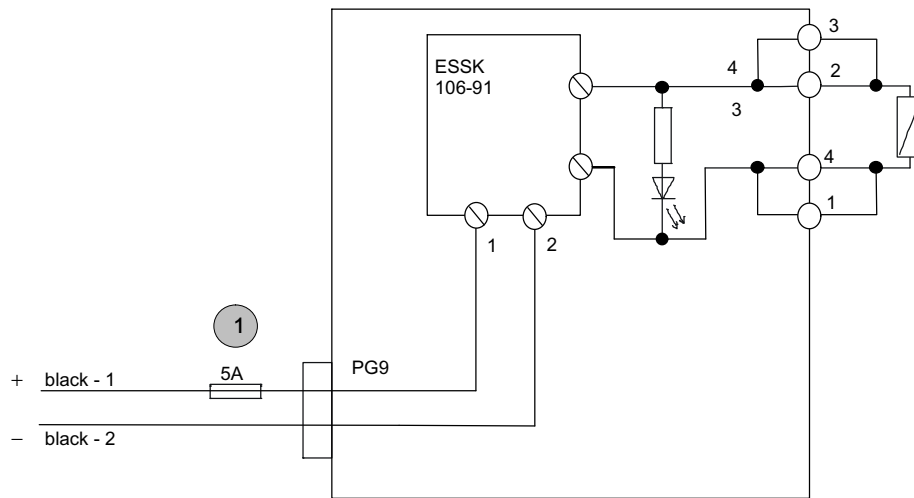

4.6 Ordering code

Description	Type	Ordering code
Controller	ELSK 106-01***/11	100026578
Accessories see chapter 12		

5 ELSK 106-02***/11 control box



5.1 Description

Options and applications are like 106-01***/11, but with additional ON/OFF-switch.

5.2 Technical data

Electrical characteristics	Unit	Description, value
Dimensions	mm	82 x 80 x 65 (L x B x H)

5.3 Functional description

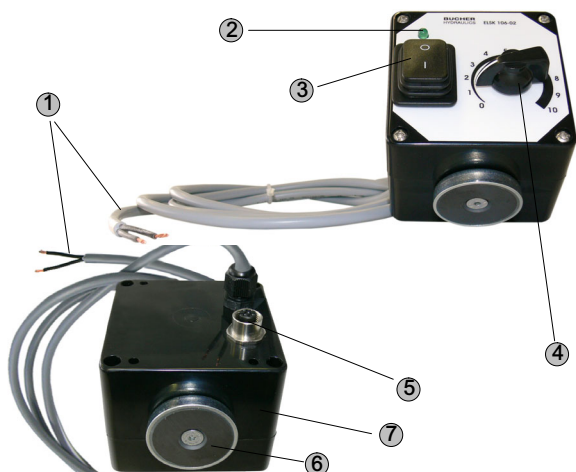

1	Power supply connection cable 1,5m, 2 x 1,5 mm ² , free cable ends
2	Control unit LED, input current
3	ON/OFF-switch
4	Rotary potentiometer no ON/OFF-switch
5	Output solenoid (4-pin M12 sleeve)
6	Magnetic clamp
7	ABS-housing: 82 x 80 x 65

5.4 Connection diagram

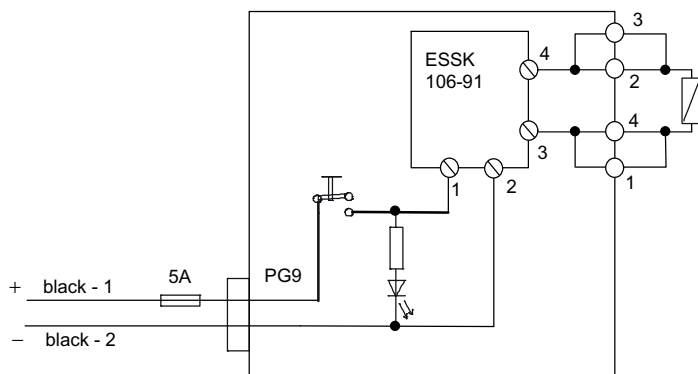

5.5 Ordering code

Description	Type	Ordering code
Controller	ELSK106-02***/11	100026579
Accessories see chapter 12		

6 ELSK 106-09*** control box



6.1 Description

The ELSK 106-106-09*** unit is used to control 2 x 2 proportional solenoids reversal. The robust aluminium housing provides two proportional amplifier modules. The potentiometer provides an indicator knob and one ON/OFF-switch in zero position. The green LED lights as soon as the ON/OFF-switch is turned on.

6.2 Technical data

General characteristics	Unit	Description, value
Dimensions	mm	134 x 106 x 70 (L x B x H)

6.3 Functional description

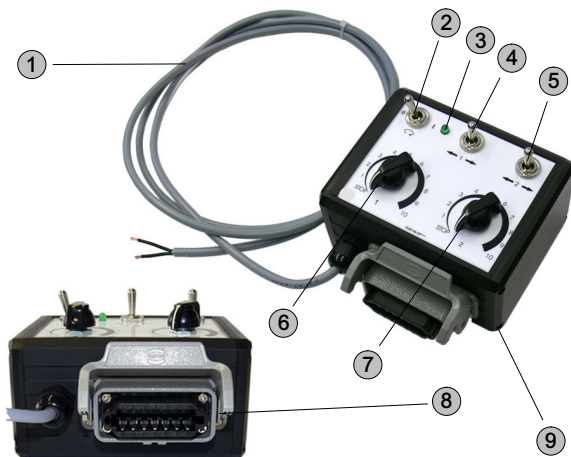

1	Power supply connection cable 1,5m, 2 x 1,5 mm ² , free cable ends
2	Power supply ON/OFF-switch
3	Input current control unit LED
4	Switch for reversal of direction for actuator 1 (ON/OFF/ON)
5	Switch for reversal of direction for actuator 2 (ON/OFF/ON)
6	Potentiometer for solenoid 1 with indicator knob and ON/OFF-switch
7	Potentiometer for solenoid 2 with indicator knob and ON/OFF-switch
8	14-pin plug insert STAF 14 (Harting)
9	Robust aluminium housing, dimensions: 134 x 106 x 70 (L x W x H)

6.4 Connection diagram

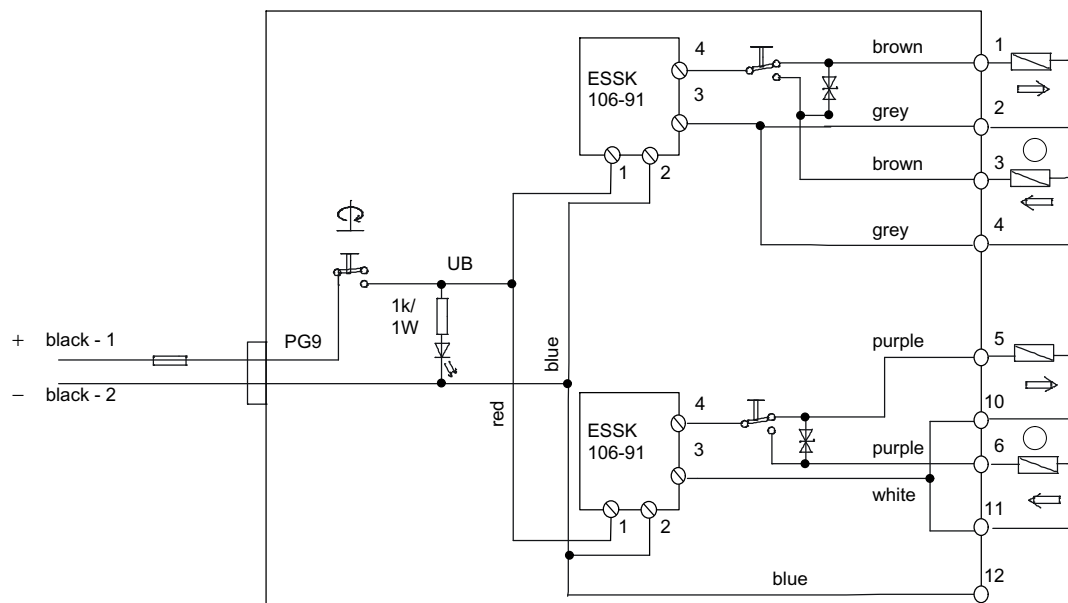

Pin 7, 8, 9, 13 and 14 are not assigned.

6.5 Ordering code

Description	Type	Ordering code
Controller	ELSK106-09***/10	100032782
Accessories see chapter 12		

7 Controller ELSK 106-10***



7.1 Description

The ELSK 106-10*** compact amplifier is used to control two proportional solenoids. There are two ESSK 106 modules integrated into the robust aluminium housing. The potentiometer provides an indicator knob and one ON/OFF-switch in zero position. 2 further ON/OFF-switches for a warning beacon and an auxiliary light. The green LED lights as soon as the ON/OFF-switch is turned on.

7.2 Technical data

General characteristics	Unit	Description, value
Dimensions	mm	134 x 106 x 70 (L x B x H)

7.3 Functional description



1	Power supply connection cable 1,5m, 2 x 1,5 mm ² , free cable ends
2	Power supply ON/OFF-switch
3	Input current control unit LED
4	ON/OFF-switch, for example warning beacons
5	ON/OFF-switch, for example auxiliary lights
6	Potentiometer for solenoid 1 (for example spreading width) with indicator knob and ON/OFF-switch
7	Potentiometer for solenoid 2 (for example spreading density) with indicator knob and ON/OFF-switch
8	14-pin socket STAF 14 (Harting)
9	Robust aluminium housing, dimensions: 134 x 106 x 70 (L x W x H)

7.4 Connection diagram

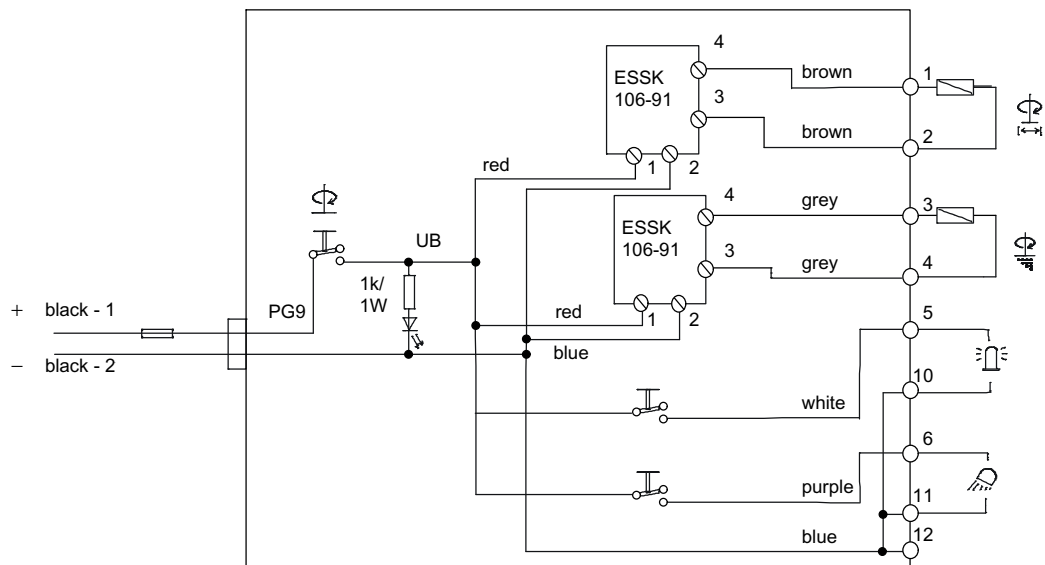

Pin 7, 8, 9, 13 and 14 are not assigned.

7.5 Ordering code

Description	Type	Ordering code
Controller	ELSK106-10***/10	100032531
Accessories see chapter 12		

8 ELSK 106-14*** control box



8.1 Description

The ELSK 106-14*** unit is used to control 2 proportional solenoids. There are two ESK 106 modules integrated into a robust aluminium housing. The potentiometers provide an indicator knob and one ON/OFF-switch in zero position. The green LED lights as soon as the ON/OFF-main switch is turned on. Built in Keylock (starter) to be connected on site. 2 further ON/OFF-switches for a warning beacon and an auxiliary light.

8.2 Application examples

- Municipal equipment
 - Snow and ice cleaning equipment
 - Sweeper
- General
 - Disc drive
 - Spreading drives
 - Brush drives

8.3 Technical data

Electrical characteristics	Unit	Description, value
Dimensions	mm	184 x 106 x 70 (L x W x H)

8.4 Functional description

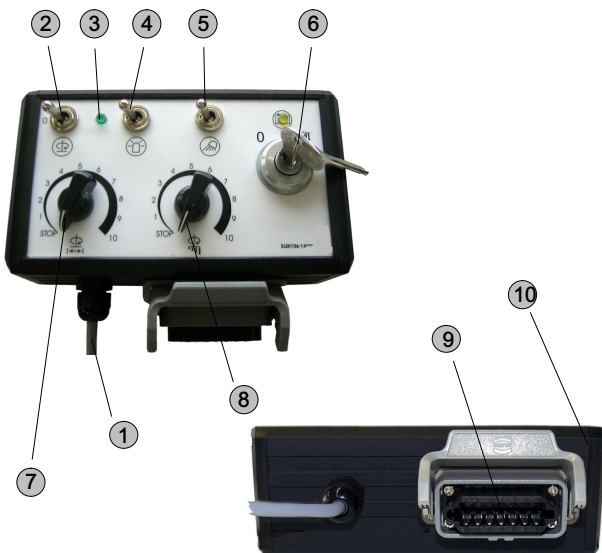

1	Power supply connection cable 1,5m, 2x1,5 mm ² , free cable ends
2	Power supply ON/OFF-switch
3	Input current control unit LED
4	ON/OFF-switch, for example warning beacons
5	ON/OFF-switch, for example auxiliary lights
6	Keylock (starter) to be connected on site.
7	Potentiometer for solenoid 1 (for example spreading width) with indicator knob and ON/OFF-switch
8	Potentiometer for solenoid 2 (for example spreading density) with indicator knob and ON/OFF-switch
9	14-pin socket STAF 14 (Harting)
10	Robust aluminium housing, dimensions: 184 x 106 x 70 (L x W x H)

9 ELSK106-15*** control box



9.1 Description

The ELSK 106-15*** unit is used to control a proportional solenoid. It consists of the ESSK 106-91*** module, fitted in a aluminium housing. The housing is provided with a front plate with an ON/OFF-switch, a green LED and a control signal potentiometer with indicator knob.

The output current varies linearly with the angle of rotation of the control signal potentiometer. The green LED lights as soon as the unit is switched on.

9.2 Application examples

- Municipal equipment
 - Snow and ice cleaning equipment
 - Sweeper
- General
 - Disc drive
 - Spreading drives
 - Brush drives

9.3 Technical data

Electrical characteristics	Unit	Description, value
Dimensions	mm	184 x 106 x 70 (L x W x H)

9.4 Functional description

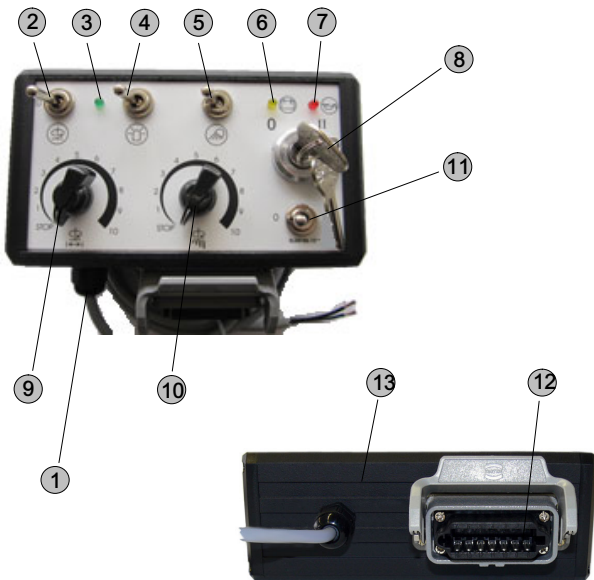

1	Power supply connection cable 1,5m, 2x1,5 mm ² , free cable ends
2	Power supply ON/OFF-switch
3	Input current control unit LED
4	ON/OFF-switch, for example warning beacons
5	ON/OFF-switch, for example auxiliary lights
6	Control LED for battery
7	Control-LED for oil
8	Keylock (starter) to be connected on site.
9	Potentiometer for solenoid 1 (for example spreading width) with indicator knob and ON/OFF switch
10	Potentiometer for solenoid 2 (for example spreading density) with indicator knob and ON/OFF-switch
11	ON/OFF-switch
12	14-pin socket STAF 14 (Harting)
13	Robust aluminium housing, dimensions: 184 x 106 x 70 (L x W x H)

9.5 Block diagram

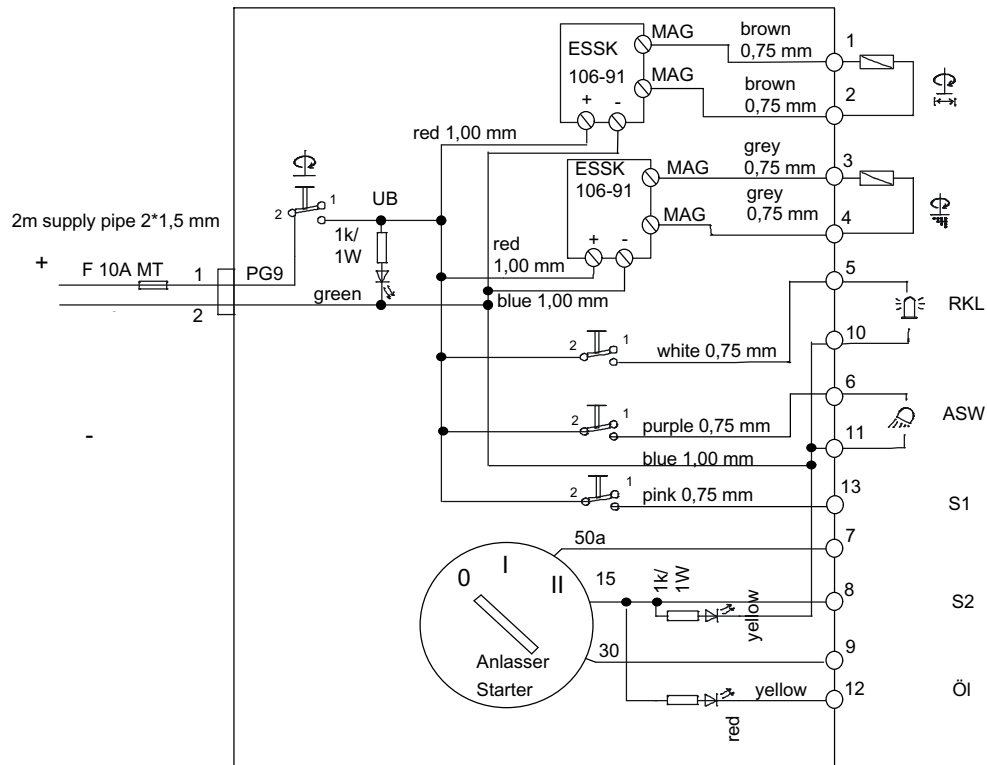

Pin 14 is not assigned.

9.6 Ordering code

Description	Type	Ordering code
Controller	ELSK106-15***	100034145
Accessories see chapter 12		

9.7 Spare part

Description	Ord. code
ON/OFF-switch	100607681

10 ELSK 106-16*** control box



10.1 Description

The ELSK 106-16*** unit is used to control three proportional solenoids. It consists of the ESSK 106-91*** module, fitted in a aluminium housing. The housing is provided with a front plate with an ON/OFF switch, a green LED and a control signal potentiometer with indicator knob.

The output current varies linearly with the angle of rotation of the control signal potentiometer. The green LED lights as soon as the unit is switched on.

10.2 Application examples

- Agricultural and forestry equipment
 - Fertiliser spreader
 - Dung spreader
 - Fodder mix and cast wagon
 - Crushing plants
- General
 - Belt drive
 - Scraper floor drive

10.3 Technical data

Electrical characteristics	Unit	Description, value
Dimensions	mm	184 x 106 x 70 (L x W x H)

10.4 Functional description

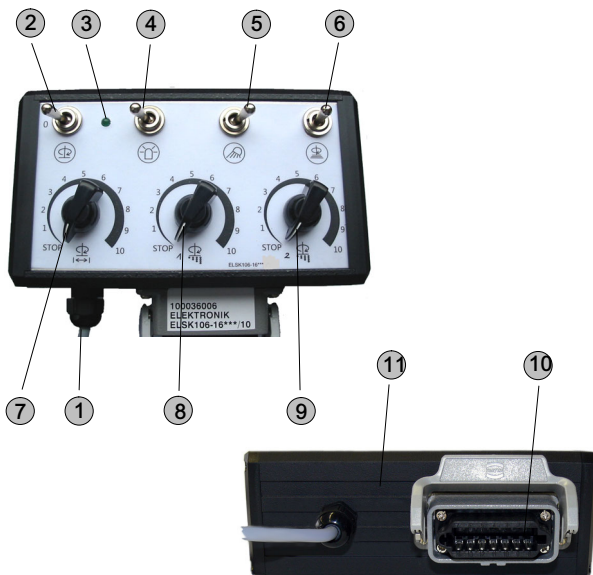

1	Power supply connection cabel 2m, 2x1,5 mm ² , free cable ends
2	ON/OFF-switch
3	Input current control unit LED
4	ON/OFF-switch, for example warning beacons
5	ON/OFF-switch, for example auxiliary lights
6	ON/OFF-switch for control the spreading density
7	Potentiometer for solenoid 1 (for example spreading width) with indicator knob and ON/OFF-switch
8	Potentiometer for solenoid 2 (for example spreading density) with indicator knob and ON/OFF-switch
9	Potentiometer for solenoid 2 (for example spreading density) with indicator knob and ON/OFF-switch
10	14-pin socket STAF 14 (Harting)
11	Robust aluminium housing, dimensions: 184 x 106 x 70 (L x W x H)

10.5 Block diagram

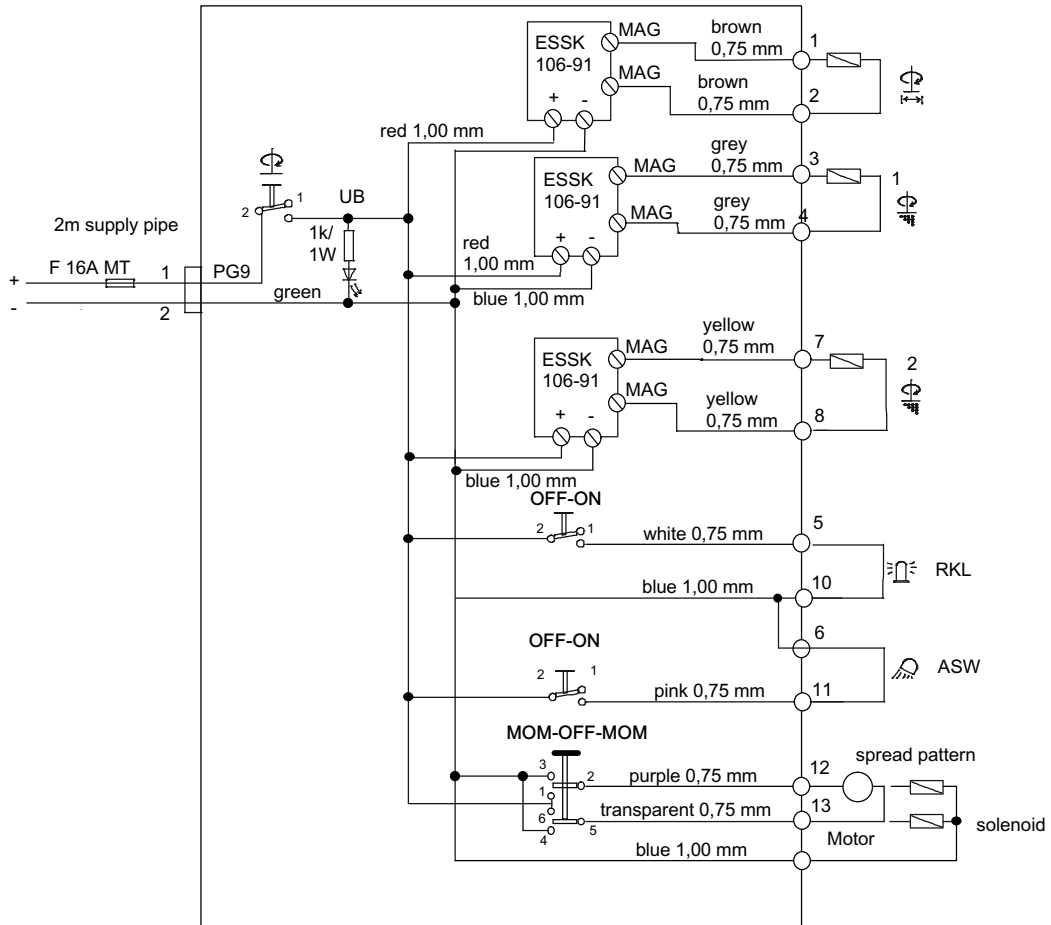

10.6 Ordering code

Description	Type	Ordering code
Controller	ELSK106-16***	100036006
Accessories see chapter 12		

11 Wiring loom

11.1 Wiring loom EKAB100-

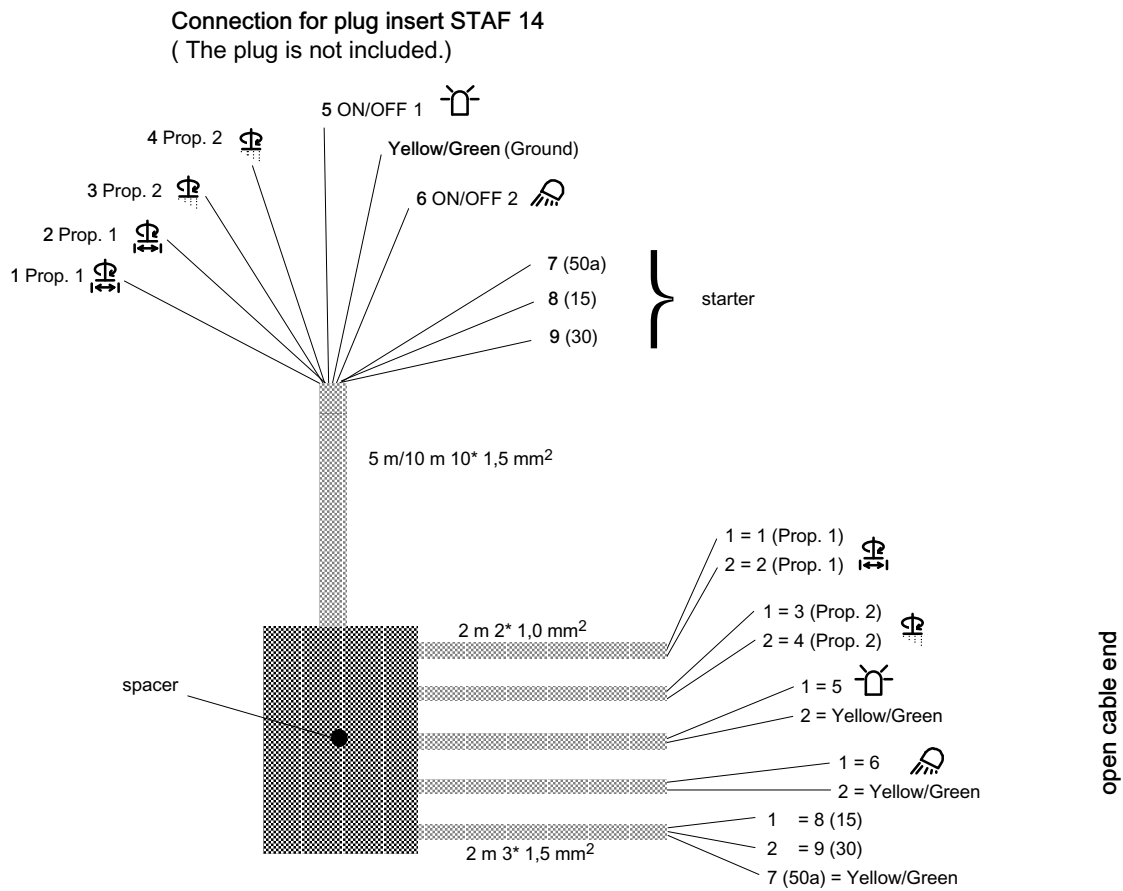

11.1.1 Ordering code

Description	Type	Ordering code
Wiring loom 5 m (5 meter 10x1 mm)	Wiring loom EKAB100-05	100153239
Wiring loom 10 m (10 meter 10x1 mm)	Wiring loom EKAB100-10	100153227
Accessories see chapter 12		

11.2 Wiring loom EKAB101-

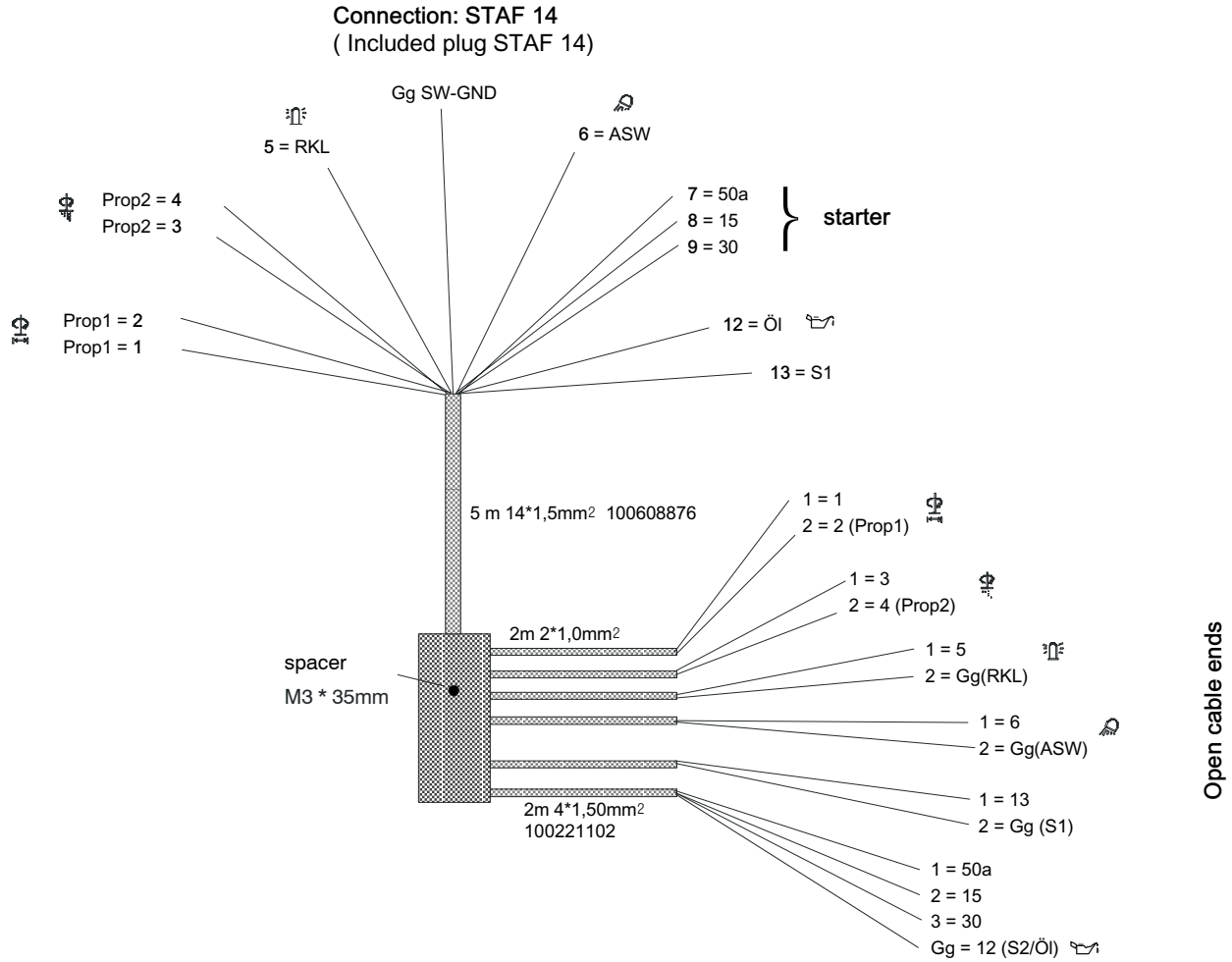

11.2.1 Ordering code

Description	Type	Ordering code
Wiring loom 5 m (5 meter 14x1,5 mm ²)	Wiring loom EKAB101-05	100153969
Accessories see chapter 12		

11.2.2 Spare parts

Description	Ord. code
Plug insert STAF 14 (Harting)	100609977
Line housing STAF 14	100609980
Cable connection PG16	100601546

12 Accessories

To connect the solenoid, a GDM 309 connector plug can be supplied. In the event of proportional valve malfunctions

that are caused by long power leads, use GDM 209D solenoid plug.

Description	ELSK 106-****	ELSK 106-01***/11	ELSK 106-02***/11	ELSK 106-09***	ELSK 106-10***	ELSK 106-14***	ELSK 106-15***	ELSK 106-16***	Part No.
Cable for power supply 2x1mm ² (lengths in meters)		x							100604380
Coil connector plug GDM 309		x							100064970
Coil connector plug GDM 209D		x							100014130
Fuse, 5 A	X	x	x						100606938
Fine fuse, 10 A, fusible link				x	x	x	x	x	100606306
Fuse holder (line mounting)	X	x	x	x	x	x	x	x	100607349
Extension cable 1 m with M12 sleeve and plug		x							100152509
Coil connecting cable 5 m, with M12 plug and GDM plug		x							100153211
Coil connecting cable 8 m, with M12 plug and GDM plug		x							100153213
Plug insert STAF 14 (Harting)				x	x	x	x	x	100609977
Line housing STAF 14				x	x	x	x	x	100609980
Wiring loom 10 m (see chapter 11.1)					x	x			100153227
Wiring loom 5 m (see chapter 11.2)					x	x	x		100153239

info.kl@bucherhydraulics.com

www.bucherhydraulics.com

© 2022 by Bucher Hydraulics GmbH, D-79771 Klettgau

All rights reserved.

Data is provided for the purpose of product description only, and must not be construed as warranted characteristics in the legal sense. The information does not relieve users from the duty of conducting their own evaluations and tests. Because the products are subject to continual improvement, we reserve the right to amend the product specifications contained in this catalogue.

Classification: 470.710..