

Flow Control Valve

Series SRCA..

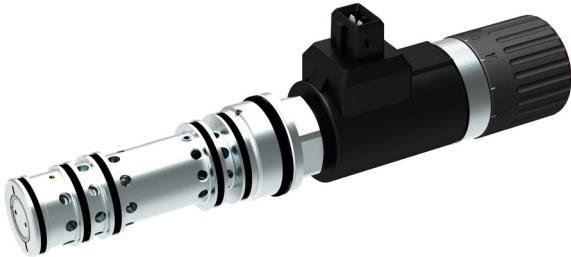

- plug-in coil for easy coil change
- flow rates are unaffected by changes in temperature or load
- compact design
- reduced Δp
- ZnNi coating (>720h DIN EN ISO 9227 NSS)

1 Description

1.1 General

Flow control valves SRCA are used to set the working speed of hydraulic actuators, and the setting is load independent and pressure compensated. When used as a 3-way valve, the higher pressure can be at either the constant flow or surplus flow port. When used as a two-way flow

control, omit the surplus-flow drilling, or plug it. The special orifice design ensures that the flow setting is largely independent of the viscosity of the fluid. The valve's cartridge construction allows to design a hydraulic system that meets the client's precise requirements.

1.2 Application examples

- Belt drives
- Spinner-plate drives
- Auger drives
- Brush drives
- Reel drives
- Pump drives for other liquids
- Fans, blowers
- ...

2 Symbols

2.1 2-way flow control



2.2 3-way flow control

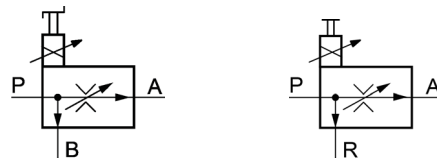

2.3 Schematic representation

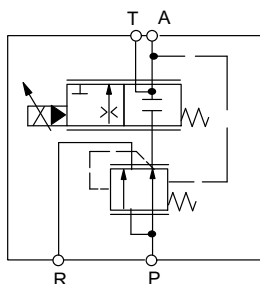

3 Technical data

General characteristics	Unit	Description, value
Design		screw-in cartridge
Flow direction		P → A controlled P → B surplus flow discharge (can be pressurised)
Seals		NBR
De-energised position		orifice closed
Mounting attitude		unrestricted; preferably with coil at bottom end (automatic air bleed)
Commissioning		bleed all air from the system (if possible, operate valve several times without load)
Electrical characteristics	Unit	Description, value
Design		high pressure; wet armature
Supply voltage	VDC	12 or 24 from an electronic controller
Power consumption	Watt	Proportional operation: 16 with 12 V and $I_{max} = 1350$ mA 16 with 24 V and $I_{max} = 675$ mA ON/OFF operation: 27 with 12 V / 24 V
Dither frequency recommended	Hz	100
Relative duty cycle		100 %
Protection class (with a properly-fitted plug)		DIN plug IP65 AMP Junior Timer IP65 Deutsch plug IP67 (DIN EN 60529)
Electrical connection		plug-base with pins to DIN EN 175301-803 AMP Junior Timer plug connector (2-pole) Deutsch plug DT04-2P-EP04
Hydraulic characteristics	Unit	Description, value
Constant flow range	l/min	10, 16, 25, 32, 40, 50 ¹⁾
Inlet flow	l/min	max. 60 ¹⁾
Operating pressure	bar	max. 250
Leakage	cm ³ /min	max. 60 at 100 bar ¹⁾ (or virtually zero if the priority flow discharges to tank)
Min. pressure difference (pressure compensator)	bar	4 ... 7
Control accuracy (as a % of the nominal flow): Load-dependency when under pressure Hysteresis when operated		max. ± 2,5 % ²⁾ max. ± 3,5 % ²⁾
Fluids		mineral oil to DIN 51524 ³⁾
Fluid temperature range	°C	-20 ... +80
Viscosity range	mm ² /s	10 ... 300
Maximum admissible level of contamination of the hydraulic fluid		ISO 4406 class 20/18/15 (see paragraph 10)

1) Values refer to an oil viscosity of 35 mm²/s (cSt).

2) For higher pressures, consult Bucher Hydraulics.

3) Values refer to the selected flow range.

4 Performance graphs

4.1 Q - I characteristic curve

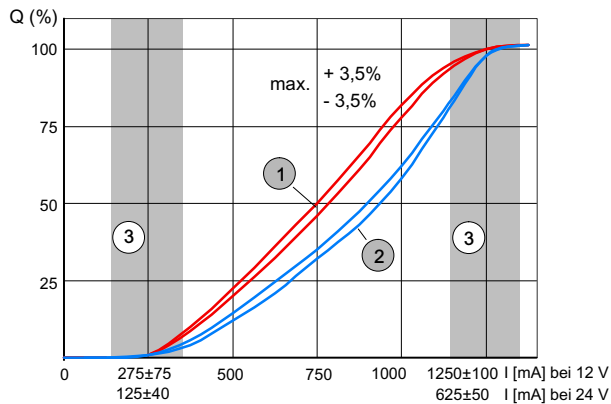

1	Q - I characteristic at 50 L
2	Q - I characteristic at 25 L
3	Fine control range

4.2 Variation in flow

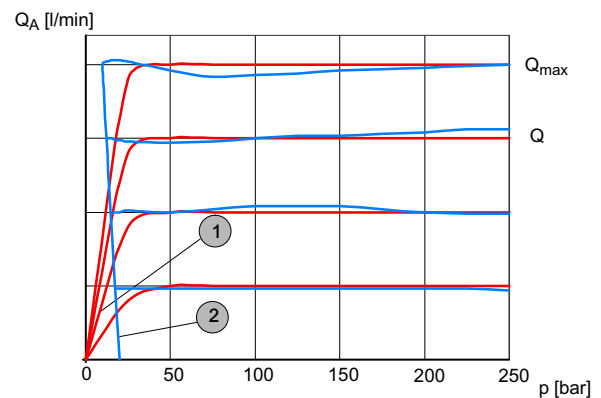

1	Q _A - constant flow pressurised
2	Q _A - surplus flow pressurised

4.3 Pressure drop during vented bypass P → B

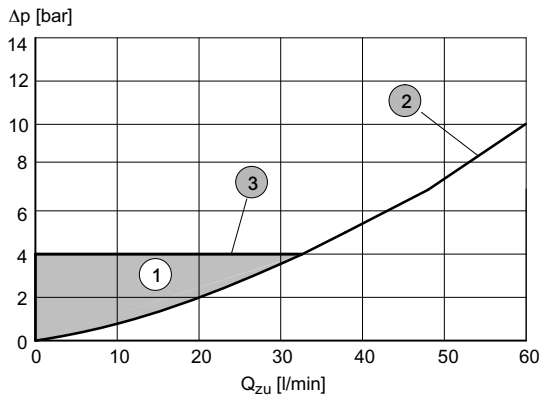

1	Pressure loss area (The actual pressure-loss characteristic is dependent on the tank pressure at port B)
2	Control valve throttling curve (Dependent on body used)
3	Control - Δp - characteristic 4 bar

4.4 Q_{zu} - Q_A characteristic curve

Flow rate at actuator port Q_A as a function of Q_{zu} and constant flow rate.

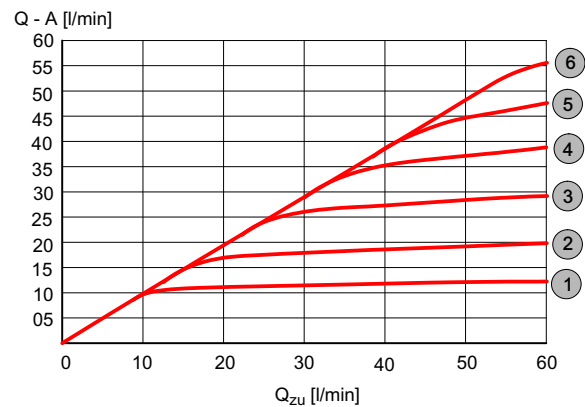

1	Constant flow range 10 l/min
2	Constant flow range 16 l/min
3	Constant flow range 25 l/min
4	Constant flow range 32 l/min
5	Constant flow range 40 l/min
6	Constant flow range 50 l/min

5 Dimensions

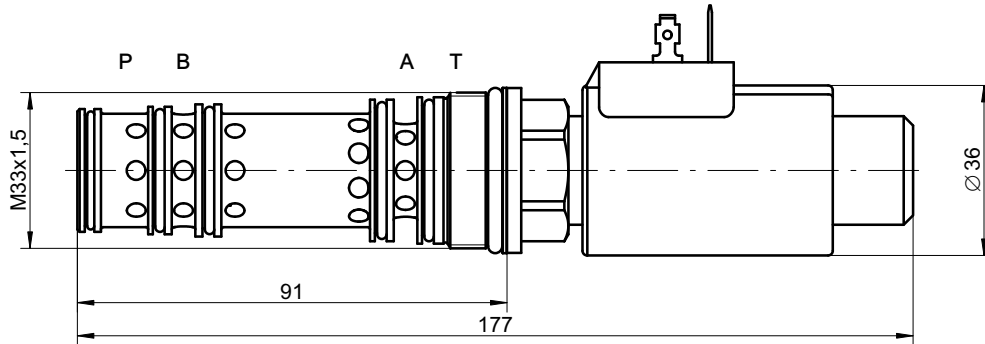

A	Priority flow (controlled)	P	Inlet
B	Surplus flow (3-way)	T	Priority flow discharge with closed orifice

6 Models

6.1 Manual override

6.1.1 Emergency pin, SRCA....S..

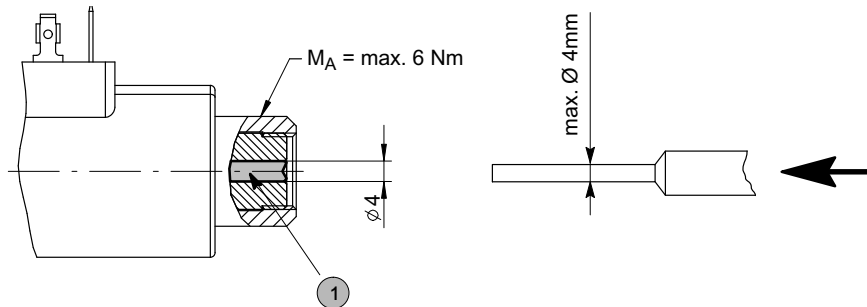

1	Emergency pin
---	---------------

IMPORTANT : By pressing the solenoid pin (1), you operate the valve ON/OFF.

6.1.2 Basic manual override, SRCA....T..

Q_0 to $Q_{max.}$ = about one turn of the handle

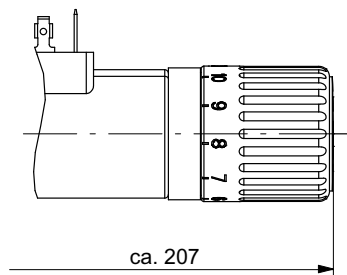

6.2 Sockets

GDM plug to DIN 43650 G	AMP Junior Timer J	Deutsch plug DT04-2P-EP04 T

7 Ordering code

		S	R	C	A	0	5	0	S	3	-	0	G	1	2	/		
Flow control valve SR																		
Cartridge																		
Size																		
Constant flow rate (10, 16, 25, 32, 40, 50 l/min) z.B. 0...50 l/min	= 050																	
Type of operator solenoid + emergency pin solenoid + deluxe manual override	= S = T																	
3-way (can also be used as a 2-way flow control)	= 3																	
Design stage (to be inserted by the factory)																		
Plug connector	GDM plug (DIN) = G AMP Junior Timer = J Deutsch plug = T																	
Proportional solenoid supply voltage	DC 12 Volt = 12 DC 24 Volt = 24																	
Options (to be inserted by the factory)																		

8 Cavity body

8.1 Cavity type GB3WM33 for 3-way flow control valves

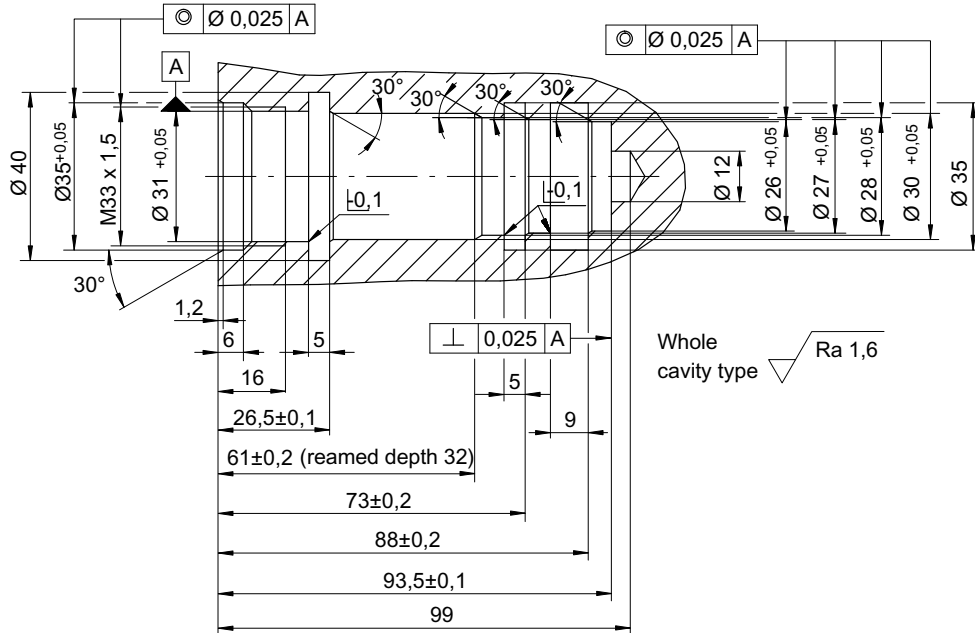

Form tool T2031 (order number: 100608916) to machine own cartridge cavities can be hired on request.

8.2 Housing variants

8.2.1 Example of a complete valve block SRCAVM2-***2-0M22

8.2.1.1 Flow control valve with solenoid and emergency pin

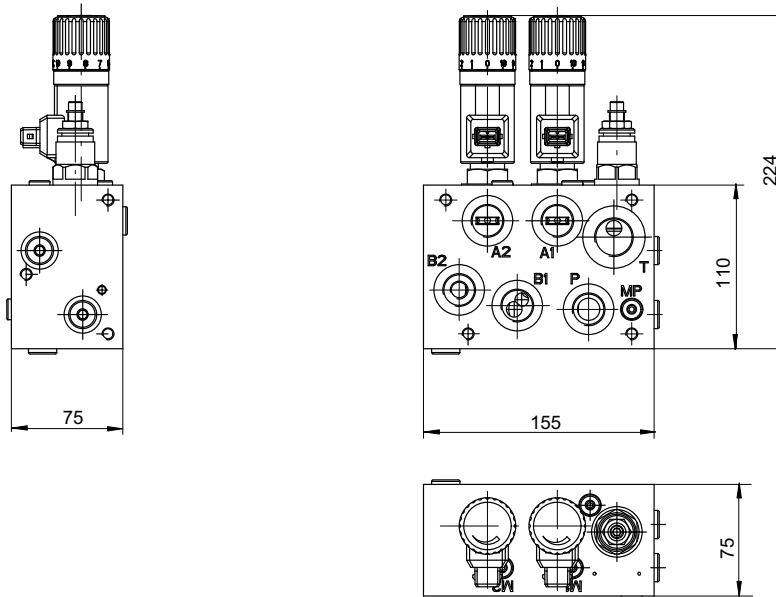

8.2.2 Example of a complete valve block SRCAVM3-***2-0M22

8.2.2.1 Flow control valve with solenoid and emergency pin

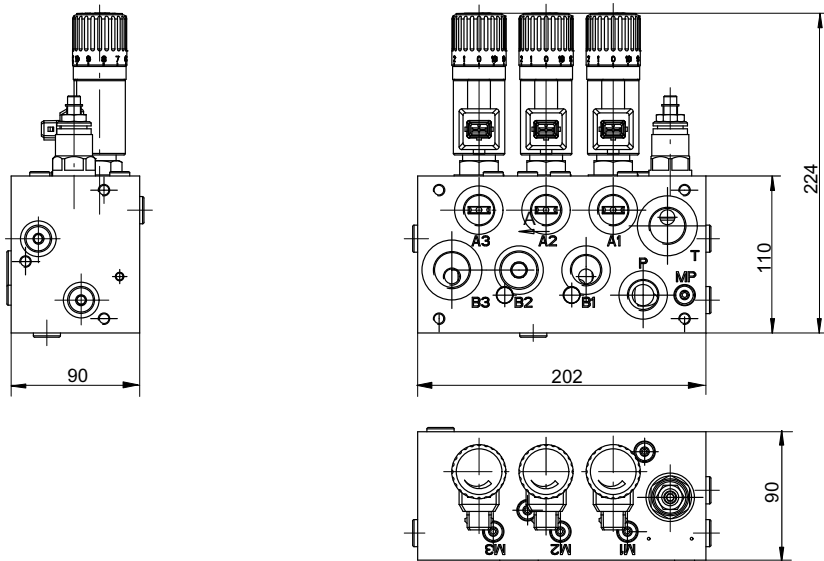

9 Fluid

Flow control valves require fluid with a minimum cleanliness level of ISO 4406 code 20/18/15.

We recommend the use of fluids that contain anti-wear additives for mixed-friction operating conditions. Fluids without appropriate additives can reduce the service life of the valves.

The user is responsible for maintaining, and regularly checking the fluid quality.

10 Fluid cleanliness class

Cleanliness class (RK) onto ISO 4406.

Code ISO 4406	Number of particles / 100 ml		
	≥ 4 μm	≥ 6 μm	≥ 14 μm
23/21/18	8000000	2000000	250000
22/20/18	4000000	1000000	250000
22/20/17	4000000	1000000	130000
22/20/16	4000000	1000000	64000
21/19/16	2000000	500000	64000
20/18/15	1000000	250000	32000
19/17/14	500000	130000	16000
18/16/13	250000	64000	8000
17/15/12	130000	32000	4000
16/14/12	64000	16000	4000
16/14/11	64000	16000	2000
15/13/10	32000	8000	1000
14/12/9	16000	4000	500
13/11/8	8000	2000	250

info.kl@bucherhydraulics.com

www.bucherhydraulics.com

© 2020 by Bucher Hydraulics GmbH, D-79771 Klettgau

All rights reserved.

Data is provided for the purpose of product description only, and must not be construed as warranted characteristics in the legal sense. The information does not relieve users from the duty of conducting their own evaluations and tests. Because the products are subject to continual improvement, we reserve the right to amend the product specifications contained in this catalogue.

Classification: 430.310.330.305.