

CED400W electronic control units



- Programmable according to IEC 61131-3 standard through PHC Studio
- 12/24 VDC applications
- 3 Hardware configurations with "ready-to-use" application software
- Designed for PHC electronic systems

The CED400W is a microprocessor-based PWM driver designed to control 8 proportional solenoid valves (4+4).

In the controllers is always loaded the standard application software that is "ready-to-use" (e.g. for analog joysticks, CAN bus joysticks of fan drive) and the control parameters can be easily adjusted through the WST STUDIO software.

It is possible to develop and download a custom application software with the PHC Studio tool. In this case access to IEC61131-3 programming language is built-in.

Also available is the PHC STUDIO Starter Kit (p/n 182400021), that contains an ECU, sample actuators, a wire harness, tutorial programs and the complete documentation.

Other features:

- Solenoid currents measurement (to compensate changes in coil resistance, temperature and supply voltage)
- Programmable Dither frequency (to reduce spool sticking)
- Protected power supply (against reversed polarity and load dump)
- Protected inputs (against short circuits to GND and to power supply)
- Protected outputs (against short circuits, reversed polarity, over-current and over-temperature)

Technical data

General

Supply voltage VK	da 8 a 32 V
Current consumption	<100 mA
Max. current output	6 A - 12 VDC
Interface	RS232, 19200, 8, n, 1
EMC compatibility	ISO13766, ISO14982
Environmental compatibility	IEC60068-2-6/27/29
Working temperature	from -40°C to +85°C
Protection degree	IP67 with mating connector attached
Weight	0.3 Kg (0.66 lb)

Analog inputs

Number	up to 4
Signal type	0/VK or from 0 to 5 V

Digital inputs

Number	up to 6
Signal type	0/VK, from 0 to 50 KHz

Proportional outputs

Number	12
Type	8HSD* + 4LSD*
Max. load	2 A

NOTE (*): HSD - High Side Driver
LSD - Low Side Driver

Electronic control units

CED400W electronic control units

Dimensions and pin-out

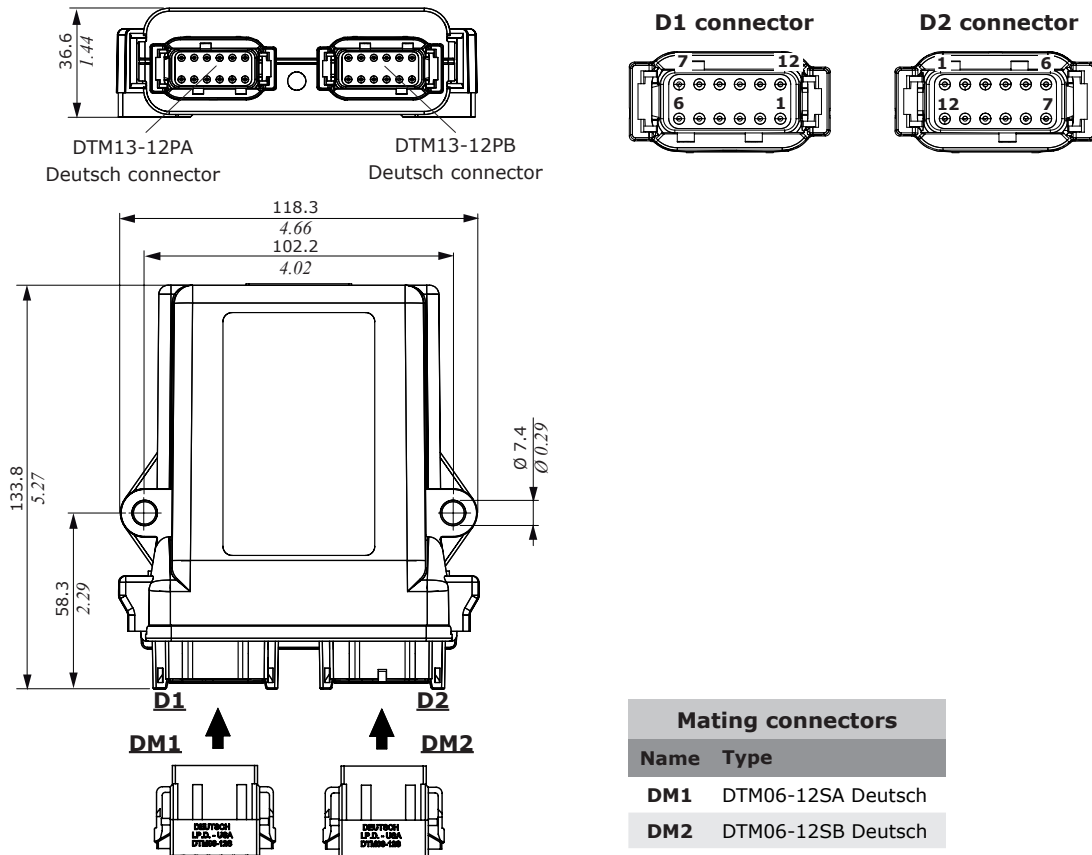

Mating connectors	
Name	Type
DM1	DTM06-12SA Deutsch
DM2	DTM06-12SB Deutsch

Application type	CED Control unit		CAN		Analog input			Digital input	Frequency input	Digital output		Sensor output
	CED pn	WST pn	Port	120R (0.5-4.5V)	0-VK (ratio)	Temp.	0/VK	0/VK	HSD	LSD	5V	
ANALOG	183337025	DCDSW0230005	0	0	4*	4*	0	4**	2**	8	4	0
CANBUS FANDRIVE	183337033	DCDSW0230012	1	0	0	0	4	6**	2**	4	2	1
CANBUS	183337037	DCDSW0230013	1	0	4*	4*	0	2**	2**	8	4	0

NOTE (*): 0-VK analog inputs are multiplexed with the 0.5-4.5V
 (**): The frequency inputs are multiplexed with the digital inputs DI_1 and DI_2

CED400W part numbers	
Description	Code
Programming cable	VCAV600018
PHC studio starter kit	182400021
USB/RS232 adapter USB 2.0 EADA70156	W0420001
USB/CANBUS adapter USB-CAN PEAK - IPEH-002021	W0420003
PHC400F standard harness	183480118
PHC400C standard harness	183480168
Connection cable	YCON140041
	YCON140067
PHC400 load harness	183480203
PHC400 load extension cable (2 m)	183490049
Battery supply cable (4 m Fuse 15A)	W0410005

NOTE : See details in the dedicated chapters

System diagram

Analog circuit configuration for 183337025

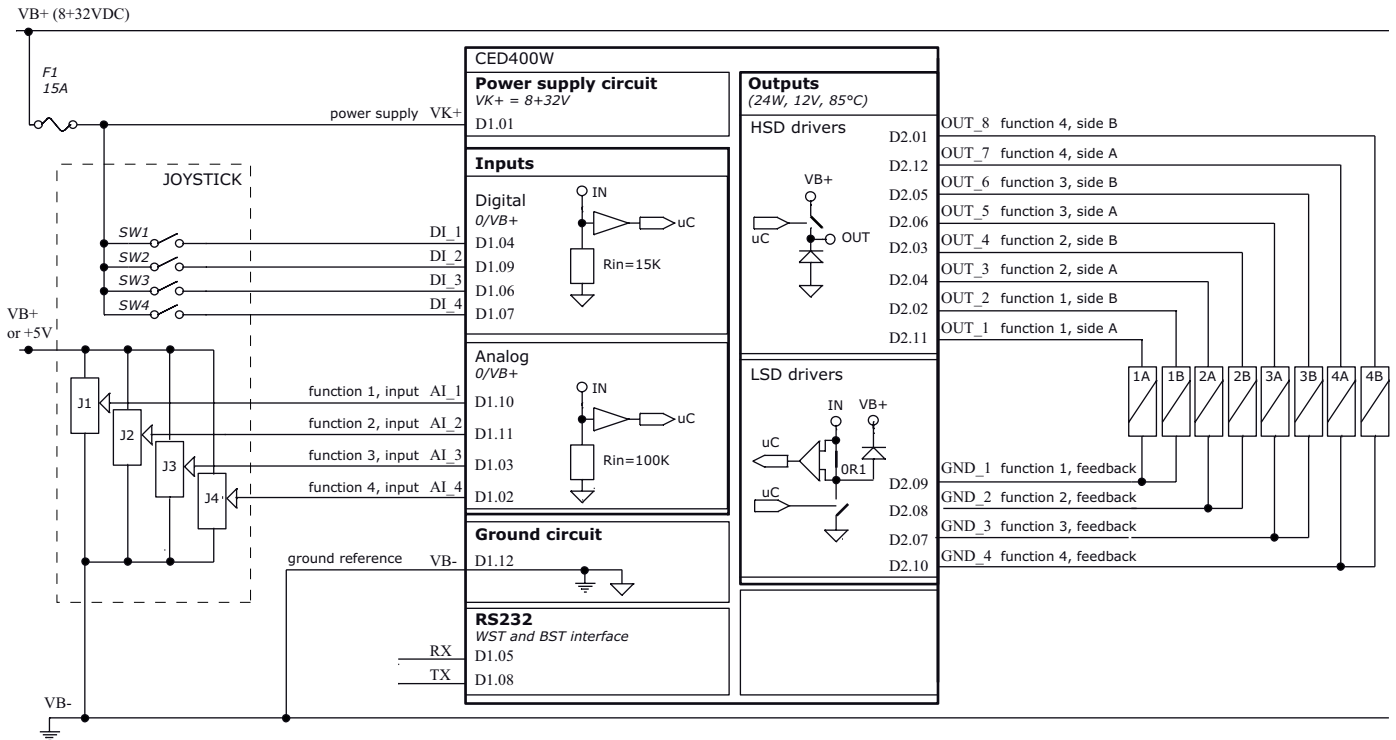

Connector PIN-OUT		
Pin	function	
	D1 connector	D2 connector
1	VK+	OUT_8
2	AI_4	OUT_2
3	AI_3	OUT_4
4	DI_1	OUT_3
5	RX	OUT_6
6	DI_3	OUT_5
7	DI_4	GND_3
8	TX	GND_2
9	DI_2	GND_1
10	AI_1	GND_4
11	AI_2	OUT_1
12	VB-	OUT_7

Electronic control units

CED400W electronic control units

System diagram

CANbus / Fan Drive circuit configuration for 183337033

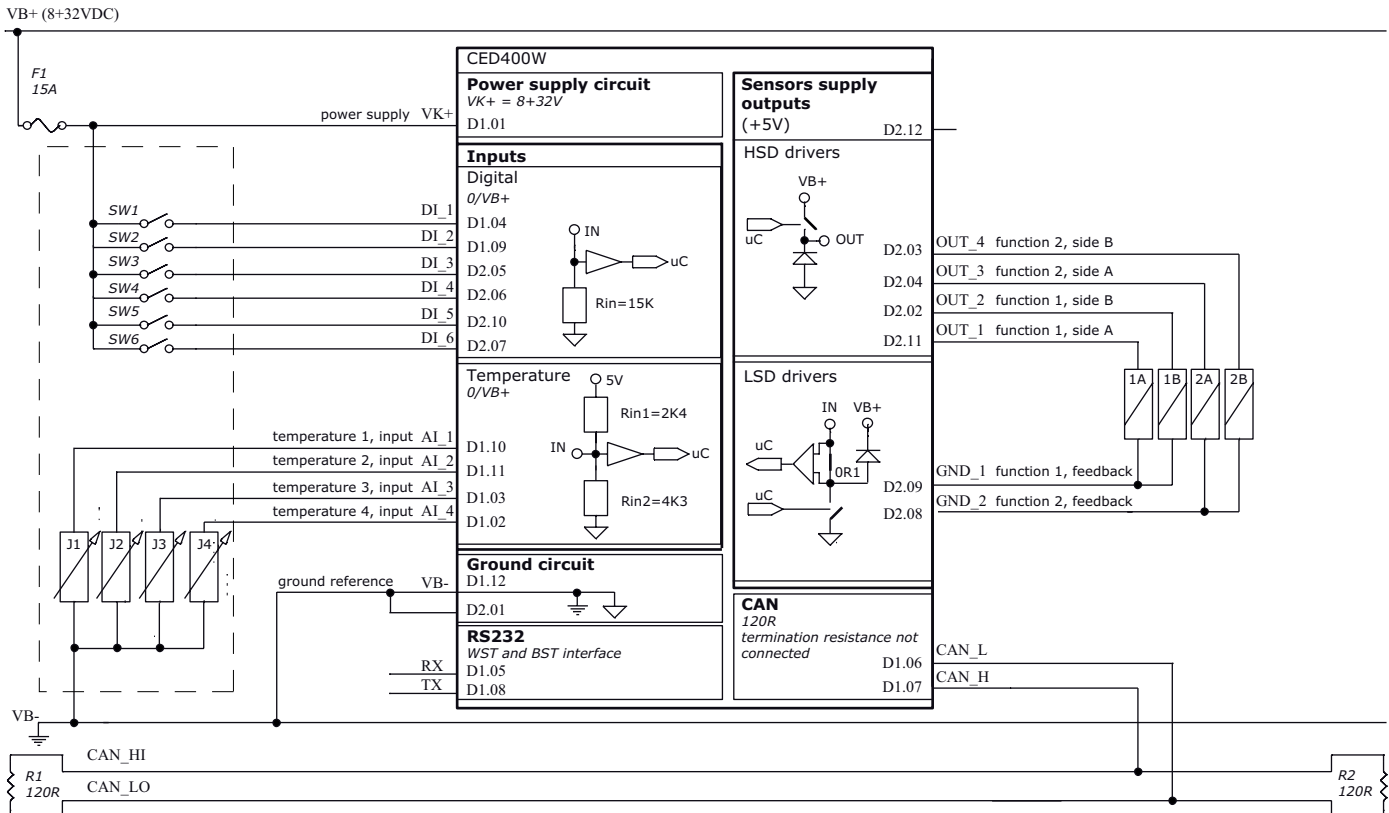

Connector PIN-OUT

Pin	function	
	D1 connector	D2 connector
1	VK+	VB-
2	AI_4	OUT_2
3	AI_3	OUT_4
4	DI_1	OUT_3
5	RX	DI_3
6	CAN_L	DI_4
7	CAN_H	DI_6
8	TX	GND_2
9	DI_2	GND_1
10	AI_1	DI_5
11	AI_2	OUT_1
12	VB-	VJ+

System diagram

CANbus circuit configuration for 183337037

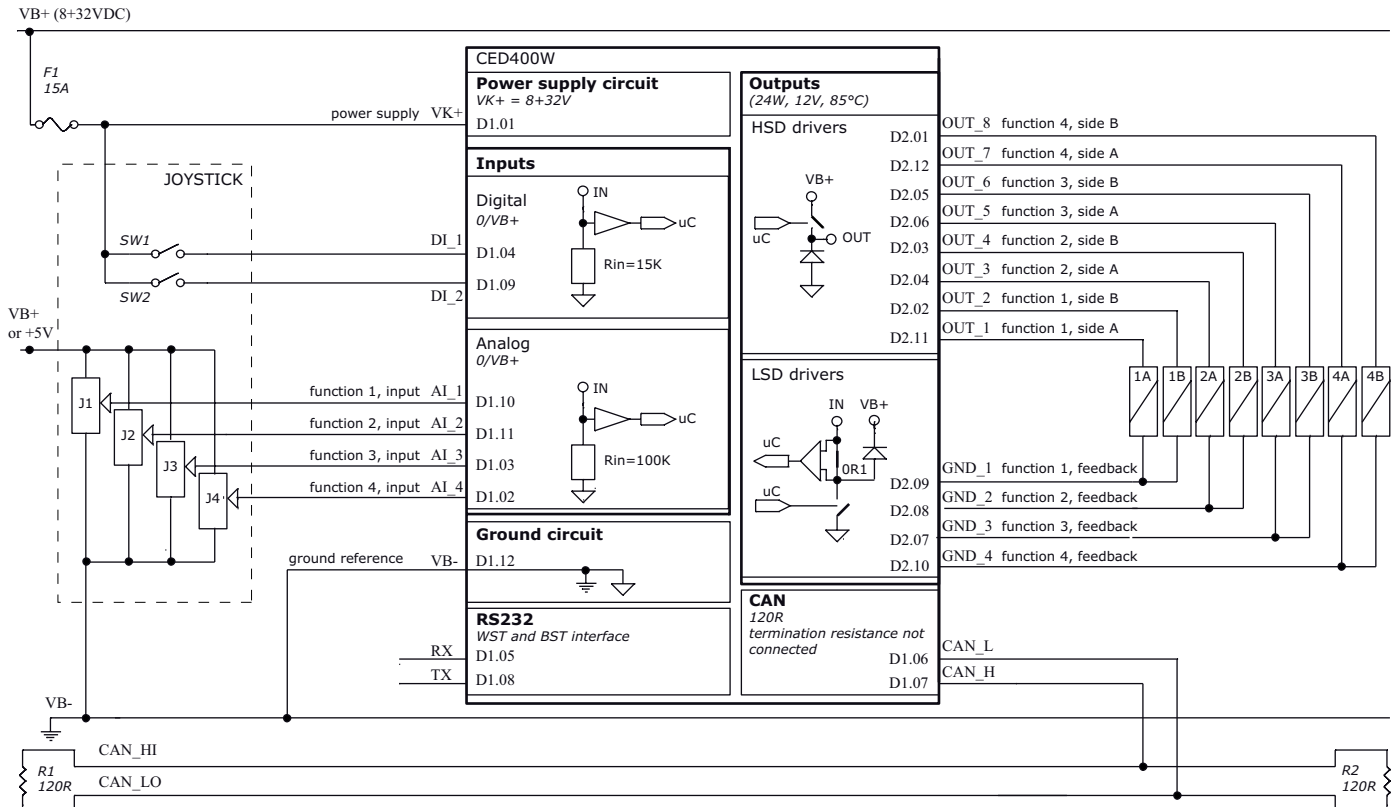

Connector PIN-OUT

Pin	function	
	D1 connector	D2 connector
1	VK+	OUT_8
2	AI_4	OUT_2
3	AI_3	OUT_4
4	DI_1	OUT_3
5	RX	OUT_6
6	CAN_L	OUT_5
7	CAN_H	GND_3
8	TX	GND_2
9	DI_2	GND_1
10	AI_1	GND_4
11	AI_2	OUT_1
12	VB-	OUT_7