



PVD200 Proportional Valve Driver

- For 12/24V applications
- Designed for PHC electronic systems

The PVD200 is a microprocessor-based PWM driver designed to control 4 proportional solenoid valves (2+2). Delivered in a potted enclosure, the PVD200 provides a flexible I/O configuration in a compact package, specifically designed to resist water, temperature, humidity and high vibrations typical of harsh environments.

The PVD200 can manage input signals coming from switches, rollers, potentiometer and PLC's, both analog and CAN bus. The working parameters (minimum and maximum currents, ramp times, dither) can be easily programmed with a PC and the WST interface.

Other features:

- Solenoid currents measurement (to compensate changes in coil resistance, temperature and supply voltage)
- Programmable Dither frequency (to reduce spool sticking)
- Protected power supply (against reversed polarity and load dump)
- Protected inputs (against short circuits to GND and to power supply)
- Protected outputs (against short circuits to GND and power supply)

Technical data	
General features	PVD200
Supply voltage	from 8 to 32 V
Current consumption (without external load)	<50 mA
Max. current output	4 A - 12 VDC
EMC Compatibility	ISO13766, ISO14982
Working temperature	from -40 to +85°C
Protection degree	IP67-IP69K with mating connector fitted
Output connector	Deutsch DT0408PA - Amphenol AT0408PA
Input connector	Deutsch DT0408PB - Amphenol AT0408PB
Analog inputs	
Number	up to 4
Signal type	2 types F: 0.5-4.5 V / 2 types P: 25%-75% Vbb
Communication port	
CAN bus 2.0B port	
Proportional outputs	
Number	4 (2 pairs)
Type	4HSD + 2LSD*
Signal	PWM on HSD*
Dither frequency	From 50Hz to 300Hz
Max. load per channel	2A
Other outputs	
2 led for status indication	
1 output	5V@50mA max.

NOTE (*): HSD - High Side Driver / LSD - Low Side Driver

Electronic control units

PVD200 proportional valve driver

Dimensions and features

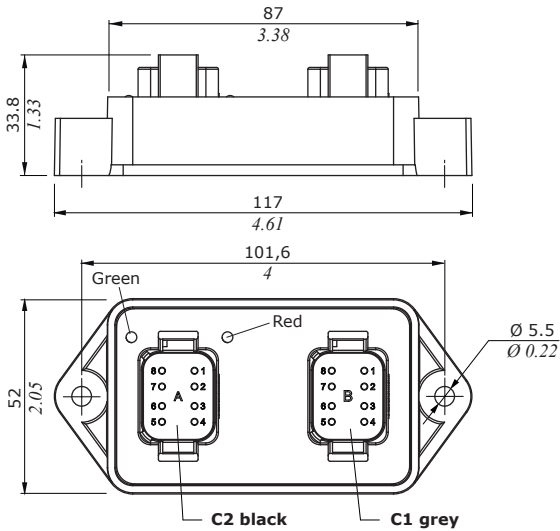

Mating connectors

Name	Type
C1	DT06-08SA Deutsch or AT06-08SA Amphenol
C2	DT06-08SB Deutsch or AT06-08SB Amphenol

LED diagnostic

	ON	OFF	Blink
Green	controller on	controller off	-
Red	-	Normal working	Error state (see WST)

PVD Valve driver			CAN		Analog input			Digital input		Frequency input	Digital output		Sensor output
Application type	Controller pn	WST pn	Port	120R (0.5-4.5V)	0-VK (ratio)	Temp.	0/5V	0/VK	0/VK	HSD	LSD	5V	
ANALOG	183380008	DCDSW0240007	1	0	4*	2**	0	2*	2**	0	4	2	1

NOTES (*): 0.5-4.5V analog inputs with neutral reference and multiplexed with the 0/5V digital inputs.
(**): 0-VK analog inputs are multiplexed with the 0/VK digital inputs.

PVD200 part numbers

Description	Code
Programming cable	VCAV600024
Connection cable	YCON140081 YCON140082
USB/CANBUS adapter USB-CAN PEAK - IPEH-002021	W0420003
Battery supply cable (4 m Fuse 15A)	W0410005

NOTE : See details in the dedicated chapters

System diagram

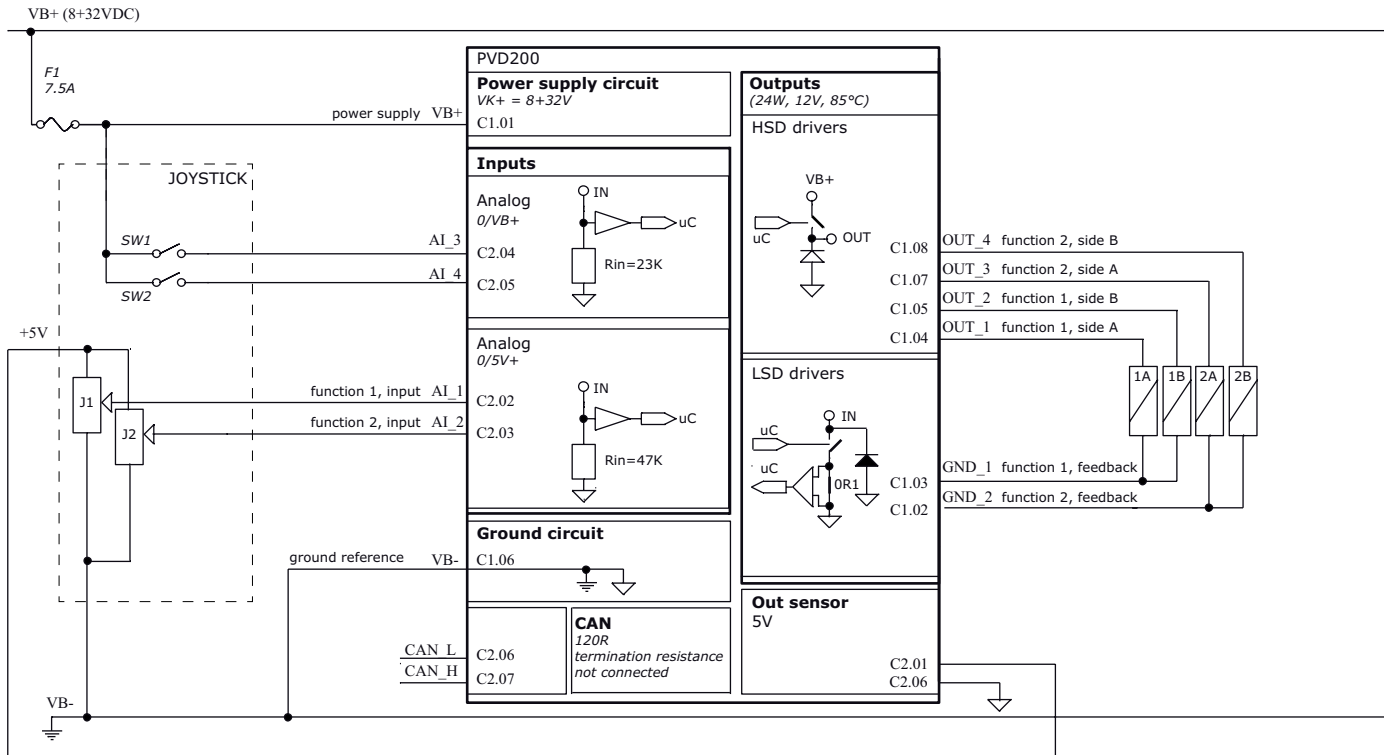

PIN-OUT connector

Pin	function	
	C1 connector	C2 connector
1	VB+	Vcc (+5V) sensor supply
2	GND_2	AI-1 (0-5V analog input/digital input)
3	GND_1	AI-2 (0-5V analog input/digital input)
4	OUT_1	AI-3 (0-Vbb analog input/digital input)
5	OUT_2	AI-4 (0-Vbb analog input/digital input)
6	VB-	CAN_L
7	OUT_3	CAN_H
8	OUT_4	GND sensor supply