

**RE 29 742/02.03**

Replaces 12.87

**Relay modules**  
**Types VT 11027 and VT 11028**

Series 1X



FF 87169

VT 11027

**Features**

VT 11027-1X and VT 11028-1X relay modules are used to cut electrical consumers in and out, e.g. electronic amplifiers, solenoids and resistive loads.

**They basically consist of:**

- Relays with LED lamp
- Capacitors with reverse polarity and overvoltage protection

**Ordering code**

**VT 110\_\_ -1X \***

Relay module 24 V = 27  
Relay module 12 V = 28

Series 10 to 19 = 1X  
(10 to 19: unchanged installation and connection dimensions)

Further details in clear text

**Preferred types**

Material no.	Type
R900010989	VT11027-1X

**Characteristic curves**

**Switching capacity with DC current (limit curve)**

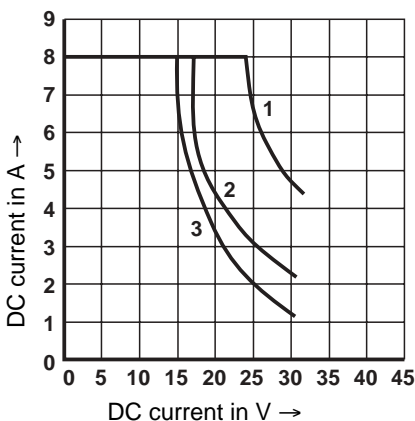

- Curve 1: 1 make-contact, resistive load (relay coil or solenoid with free-wheeling diode)
- Curve 2: 1 make-contact, inductive load L/R = 30 ms
- Curve 3: 1 make-contact, inductive load L/R = 40 ms

**Max. control voltage of coil under nominal contact load**

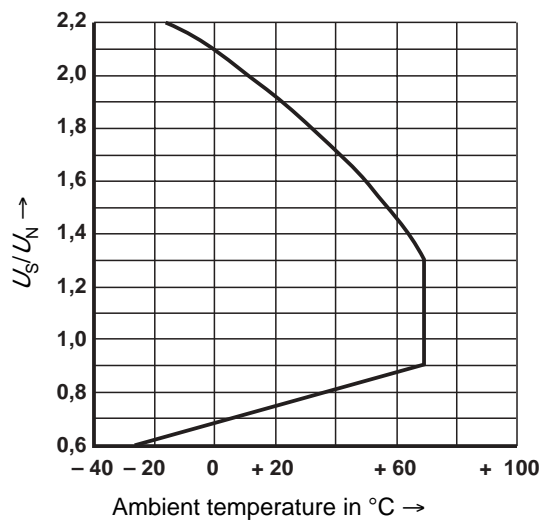

© 2003 by Bosch Rexroth AG, Industrial Hydraulics, D-97813 Lohr am Main

All rights reserved. No part of this document may be reproduced or stored, processed, duplicated or circulated using electronic systems, in any form or by means, without the prior written authorisation of Bosch Rexroth AG. In the event of contravention of the above provisions, the contravening party is obliged to pay compensation.

## Technical data (for applications outside these parameters, please consult us!)

Contacts			
Number of contacts			1 make contact element
Contact version			Single contact
Switching voltage		$U_{\max} \sim$ : $U_{\max} =$ :	24 V + 20 % 36 V (see diagram)
Continuous current/breaking current		$I_{\max}$ :	See diagram
Contact material			AgCdO (this contact material is not suitable for switching small currents!)
– Coil			
Nominal voltage	– VT 11027	$U_N$ :	24 V
		$R_{\text{coil}}$ :	~ 720 $\Omega$
Nominal voltage	– VT 11028	$U_N$ :	12 V
		$R_{\text{coil}}$ :	~ 210 $\Omega$
Nominal power		$P$ :	ca. 500 mW
Voltage range			See diagram
Release voltage at 25 °C		$U_R$ :	$\geq 0.15 \cdot U_N$
– General data	Mechanical service life		$\geq 20 \cdot 10^6$ switching cycles
Maximum switching frequency	– mechanical		72000/h
	– electrical		3000/h
	Response time	$t$ :	ca. 4 ms
	Release time	$t$ :	ca. 6 ms
	Chatter time	$t$ :	ca. 2 ms
Technical data of capacitor:			
	General data		2200 $\mu\text{F}$ / 50 V (switching-resistant)
	Oversvoltage protection		VDR 39 V / 1 mA
Technical data of housing:	Installation position		Optional
Ambient temperature range		$t$ :	– 25 °C to + 70 °C
Weight (total)		$m$ :	ca. 0.1 kg

## Pin assignment and block circuit diagram

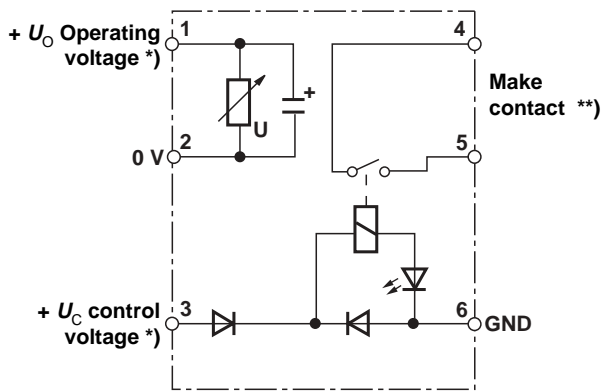

**Caution:** \*) With polarity reversal → short-circuit!  
 \*\*) Switch capacitive loads only with a sufficiently dimensioned series resistance!

## Unit dimensions (dimensions in mm)

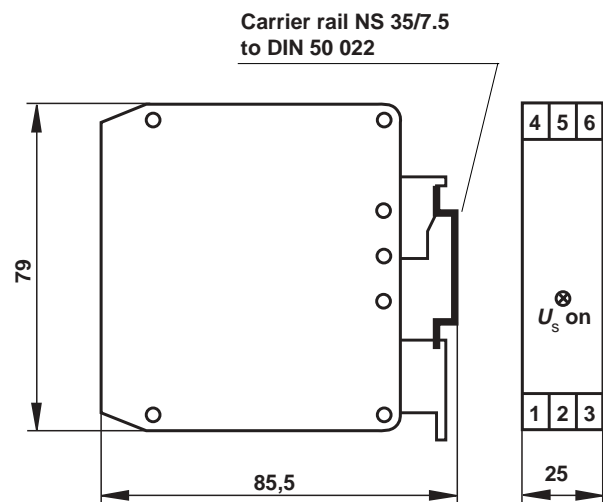

### Bosch Rexroth AG Industrial Hydraulics

D-97813 Lohr am Main  
 Zum Eisengießer 1 • D-97816 Lohr am Main  
 Telefon 0 93 52 / 18-0  
 Telefax 0 93 52 / 18-23 58 • Telex 6 89 418-0  
 eMail documentation@boschrexroth.de  
 Internet www.boschrexroth.de

### Bosch Rexroth Limited

Cromwell Road, St Neots,  
 Cambs, PE19 2ES  
 Tel: 0 14 80/22 32 56  
 Fax: 0 14 80/21 90 52  
 eMail: info@boschrexroth.co.uk

The data specified above only serves to describe the product. No statements concerning a certain condition or suitability for a certain application can be derived from our information. The details stated do not release you from the responsibility for carrying out your own assessment and verification. It must be remembered that our products are subject to a natural process of wear and ageing.