

Complete modular solutions

Electrohydraulic Control Solutions for Slurry Tankers



1800-OILSOL
1800-645765

<https://oilsolutions.com.au/>

sales@oilsolutions.com.au

Indicator

ISOBUS Terminal and Functions

Description of the operating concept

The operating concept is intuitive and easy to handle.

There are four operational levels: • filling • spreading • manual single operation • operator-specific settings

The slurry tanker itself is partially equipped with buttons which can be used to control functions directly.

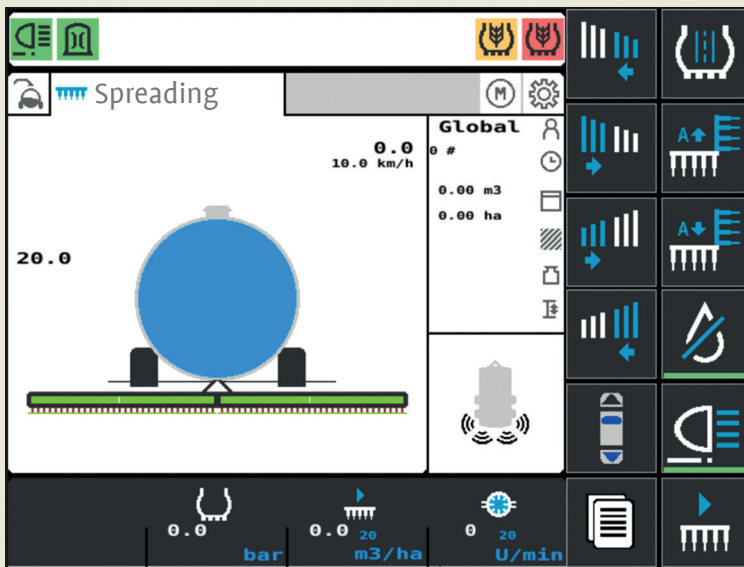

Statusbar

The statusbar at the top of the ISOBUS display shows the operating status of the symbols.



Soft-key row

The softkeys are freely configurable:
The symbols can be placed freely in the designated area.

Infobar

The infobar at the bottom of the ISOBUS display shows various information such as driving speed, tire pressure, position of the hitch control, etc..

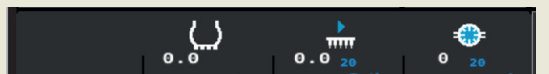

Controller

The Components Used

UT Universal terminal – ISOBUS terminal



It is possible to connect either a standard ISOBUS display or the ISOBUS tractor display to the controller.

JCM-501 ISOBUS Head Unit



CAN-BUS	2 x CAN 2.0: CANopen / ISOBUS...
USB	2 x USB 2.0 ports
RS232	RX & TX data transfer
RTC	Real time clock, battery life up to 10 years
Power supply	8 to 32 V DC

JXM-IO-E30 Slave Modul



Inputs	8 x analog, 4 x digital (input frequency 0,1Hz...10kHz)
Outputs	4 x PWMi (3Amp) + 6 x PWM (7Amp) 4 x digital, separate UB supply for sensors
CAN-BUS	1 x CAN 2.0 A/B (J1939, CANopen)



Topology and functions

Electrohydraulic Control Solution

Job data is transferred from the farm management system via USB stick or telemetry to the task controller for the JCM-501 implement ECU.

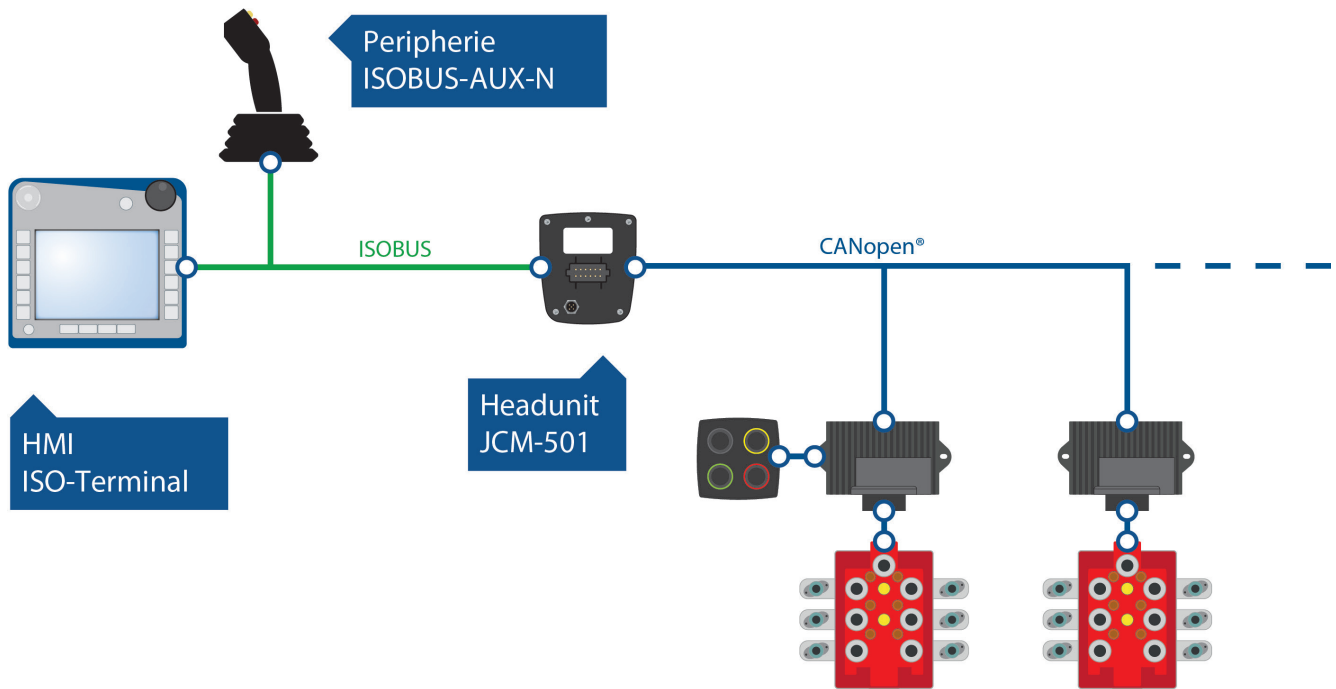

The most important functions

New functions can be easily expanded due to the modular structure of this electrohydraulic solution.

Precision farming functions (ISOBUS-Norm)

- Virtual terminal
- AUX-N
- Freely configurable joystick
- Task controller TC-BAS
- Order management
- Task controller, section control
- Site specific spreading
- Task controller TC-Geo
- GPS connection

Software functions

- Softkeys freely placeable
- Functions are configured via text files
- Various counters
- Input and output test
- Diagnostics of cable breaks and short circuits to ground
- User management
- Log file diagnostics
- Extensible software

Chassis functions

- Articulated drawbar
- Steering axle
- Top cylinder
- Hitch control
- Hydraulic suspension
- Axle lift
- Steering system
- Tire pressure control system

Future-proof

Future-proof: New sensor technologies will be added to the configuration file as an additional option. Software updates can be transferred via USB stick.

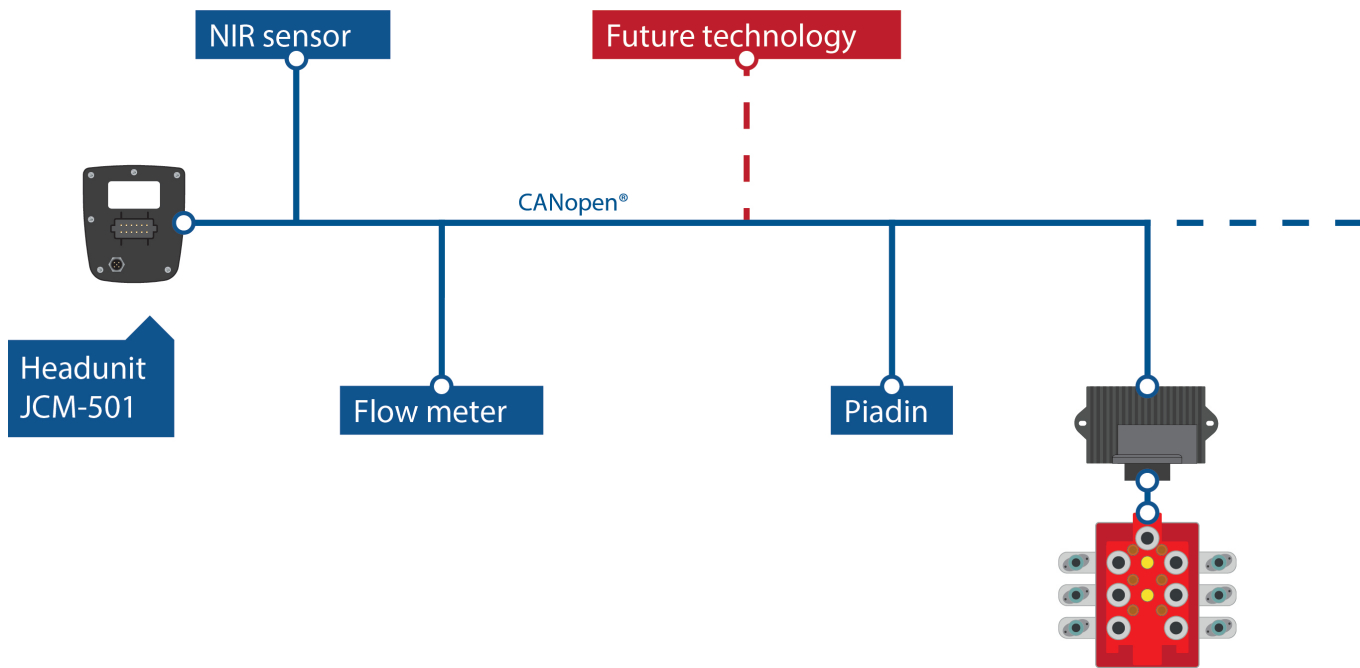

Procedures

Filling
Spreading
Initialization
Manual mode
Settings menu

Suction arm

All hinges on/off and proportional
1 x pivot
3 x hinges to fold and unfold
Telescopic function
Turbo filler

Distribution device

Disc harrow
Baffle plate
Strip tillage
Drag shoe
Drag hose
Exacut (precision distributor)

Sensors

Ready for NIR sensor
Ready for Piadin admixture
Flow measurement

Slurry tank functions

Flow meter
Ready for NIR sensor
Electric three-way-valve
Pump with control
Rotacut (wet cutter)

General functions

Rotating light
Working light
Central lubrication

System solutions for towed machines (EPOM)

Comprehensive Functionality

Bucher Hydraulics is a very capable partner for electrohydraulic systems especially for use with towed machines in agriculture. The components are characterized by their high reliability, they deliver optimum service even with strongly fluctuating temperatures, high mechanical loading and electromagnetic interference.

Valve blocks from the EPOM range feature a sectional design and can consist of up to 10 LVS directional valve sections with flanged SVH04 or D-DS06 segments. The comprehensive functionality of the LVS valve series increases the efficiency and can be extended by simple, cost-optimized directional spool valves of the D-DS06 series or directional seat valves of the SVH04 series.

Features of the modular control block

- 9 bar working- Δp
- Usable with all pump systems
- Tank pressure rating up to 210 bar
- Load sensing pressure booster
- All the necessary hydraulic functions can be integrated into one valve block: e.g. steering, axle-lift, axle-suspension, double-acting hitch-control valve, etc



System solution EPOM with LVS / SVH04

General technical data LVS valves	Unit	Description, value	
Fluid temperature	°C	-30 ... +80	
Viscosity range	mm ² /s	For reliable operation	380 ... 10
		For rated performance	80 ... 20
Pressure	bar	LVS08: pump port max. 250, actuator port max. 280, tank port max. 210 static	
		LVS12: pump port max. 350, actuator port max. 400, tank port max. 210 static	
Flow rate	l/min	Maximum flow at the P inlet = 200	
		Maximum flow at the actuator ports A + B = LVS08 = 45 with control Δp of 9 bar LVS12 = 150 with control Δp of 9 bar	

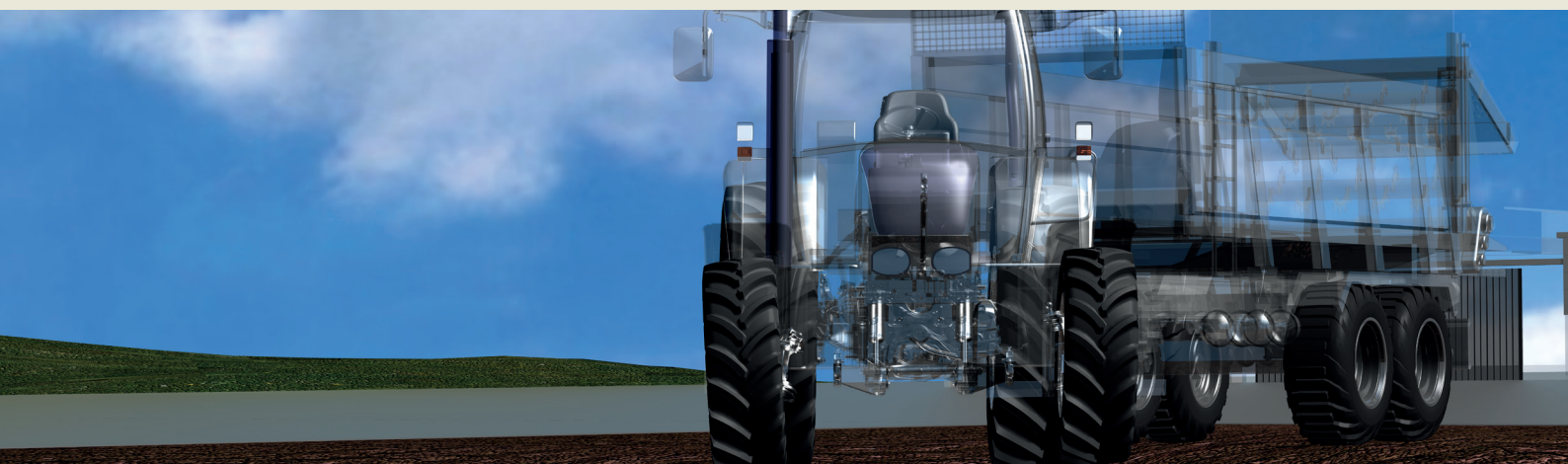

Modular and Flexible

The EPOM range (Externally Propelled Off-Highway Machines) includes comprehensive functionality, which can be easily combined with customized system solutions and offers the ideal solution for every towed machine.

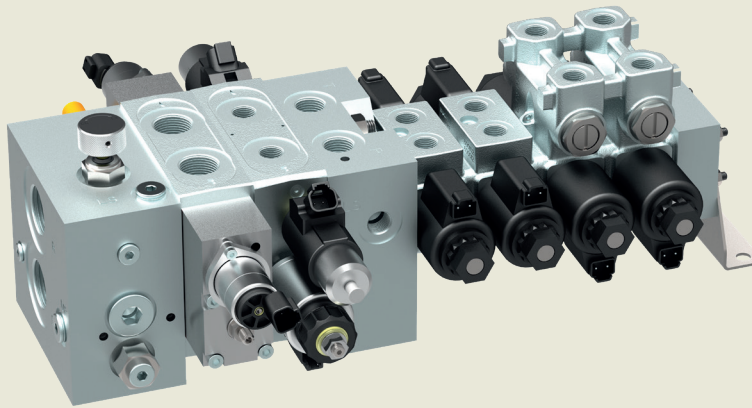

Proportional directional valves, series LVS
Up to 10 directional valve sections can be linked to one valve block.

Directional spool valve, series D-DS06
Up to 11 sections can be flange-mounted.

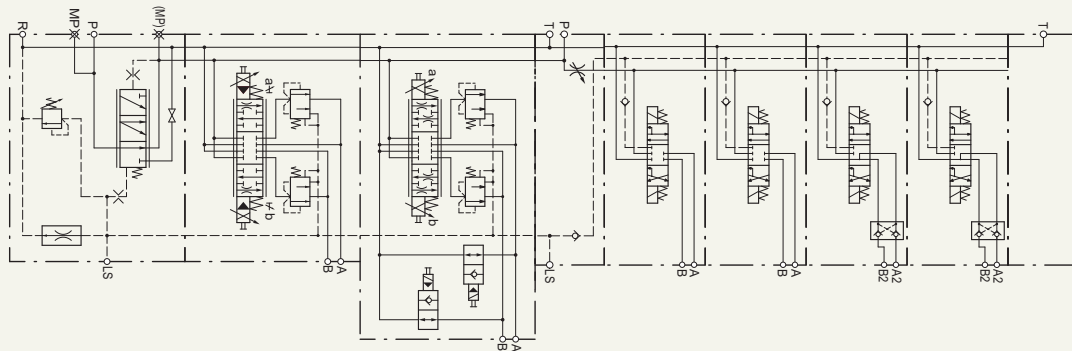

Smart Solutions. Superior Support.

Bucher Hydraulics GmbH

Industriestraße 1
DE-79771 Klettgau

info.de@bucherhydraulics.com
www.bucherhydraulics.com