

NEW

Fan Drive

Electrohydraulic Fan Drive Systems



start



1800-OILSOL
1800-645765

<https://oilsolutions.com.au/>

sales@oilsolutions.com.au

 **walvoil**
FLUID POWER E|MOTION

A member of



Fan Drive

Electrohydraulic Fan Drive Systems



- Long life expectancy
- Optional speed sensor
- Two speed, variable speed or reversible configurations
- Optional outrigger bearing
- Reduced overall dimension
- Electronic control available

Walvoil Fan Drive is a new range of vehicle cooling systems based on external gear motors; these types of motors are widely used in modern hydraulics due to their high performance, long life service and low maintenance costs.

An electrohydraulic Fan Drive offers significant advantages if compared with traditional solutions with electric or belt drives. Maximum performance is achieved by coupling the Fan Drive with the Walvoil CED400W electronic control units, fully programmable.

GENERAL WORKING CONDITIONS

Displacement		from 4 to 31.5 cm ³ /rev from 0.24 to 1.92 in ³ /rev
Max continuous pressure	up to	250 bar - 3600 psi
Fluid		hydraulic mineral oil-based
Fluid temperature range	with NBR (buna N) seals	from -20 to +80 °C from -4 to +176 °F
	with FPM (viton) seals	from -20 to +100 °C from -4 to +212 °F
Viscosity	Recommended	from 15 to 92 mm ² /s (cSt)
	Permitted for starting	2000 mm ² /s (cSt)
Max level of contamination	Recommended for operating pressure > 150 bar (2150 psi)	20/18/15 ISO 4406 class 9 (NAS 1638)
	Recommended for operating pressure < 150 bar (2150 psi)	21/18/15 ISO 4406 class 10 (NAS 1638)

Tecnichal data

GROUP 2SM	Displacement		Max continuous pressure				Max intermittent pressure				Max rotation speed rpm
	cm ³ /giro	in ³ /rev	S - D		R		S - D		R		
			bar	psi	bar	psi	bar	psi	bar	psi	
2SM 040	4.0	0.24	230	3330	230	3330	270	3900	230	3330	4000
2SM 060	6.0	0.37	230	3330	230	3330	270	3900	230	3330	4000
2SM 080	8.5	0.52	230	3330	230	3330	270	3900	230	3330	3500
2SM 110	11.0	0.67	230	3330	230	3330	270	3900	230	3330	3500
2SM 140	14.0	0.85	230	3330	230	3330	270	3900	230	3330	3500
2SM 160	16.5	1.01	230	3330	200	2900	240	3480	200	2900	3500
2SM 190	19.5	1.19	210	3050	185	2680	220	3190	185	2680	3300
2SM 220	22.5	1.37	190	2750	170	2460	200	2900	170	2460	2800
2SM 260	26.0	1.59	170	2470	150	2180	180	3600	150	2180	2500
2SM 310	31.5	1.92	130	1890	120	1740	140	2030	120	1740	2200

NEW

Variable speed Fan Drive system

Motor with a proportional pressure relief valve and an anti-cavitation valve integrated in the rear cover. The max speed of the motor can be controlled independently by the engine speed for optimal performance and lower energy consumption. In case of power failure the max speed is achieved. In case of sudden engine stop, the anticavitation valve prevents any fan damage.

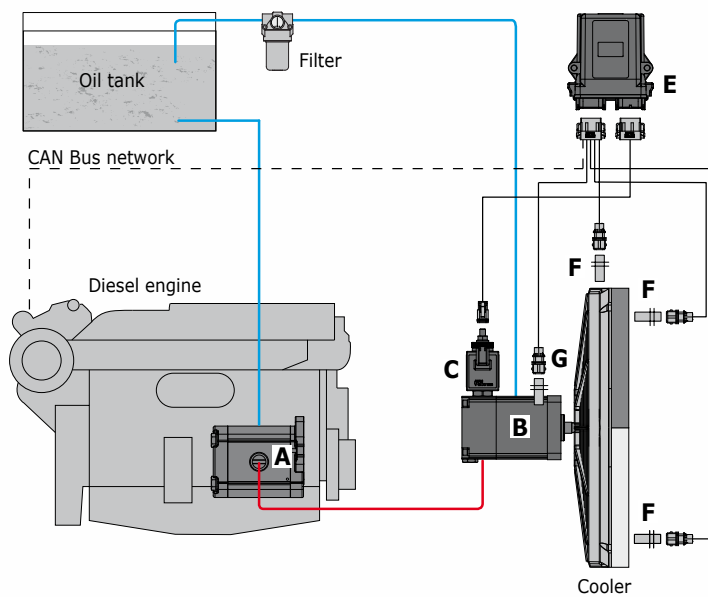

- A** Gear pump
- B** Gear motor
- C** Proportional pressure relief valve
- E** Electronic control unit
- F** Temperature sensor
- G** Speed sensor

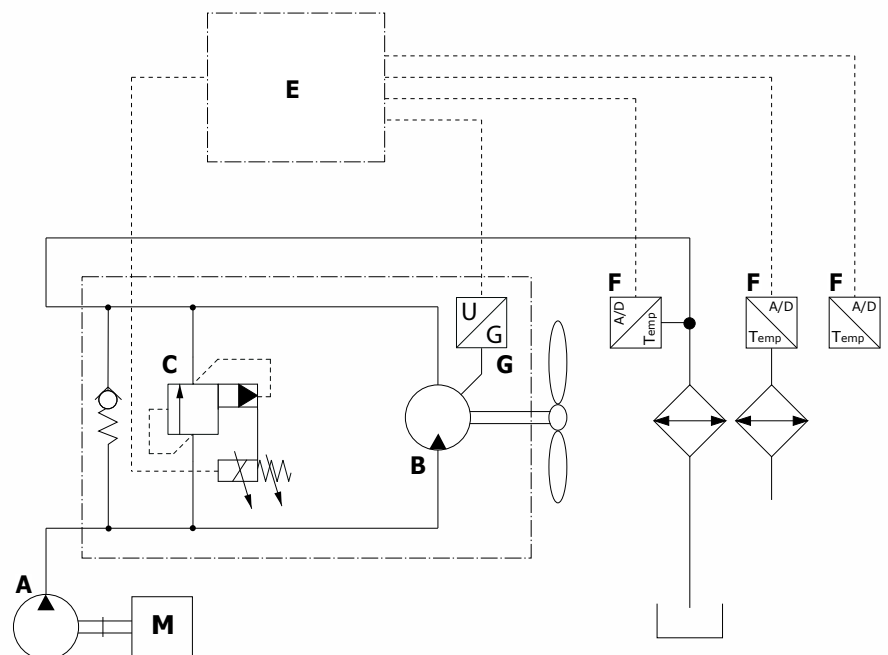
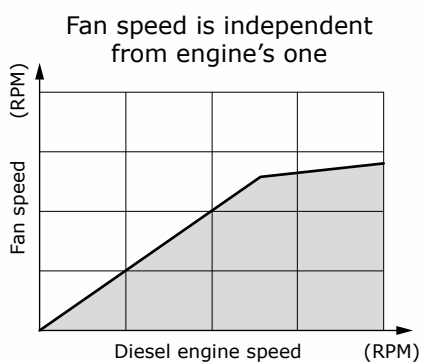

Fan Drive

Electrohydraulic Fan Drive Systems

Variable speed Fan Drive system

Example of standard Fan Drive motor with proportional pressure relief valve.

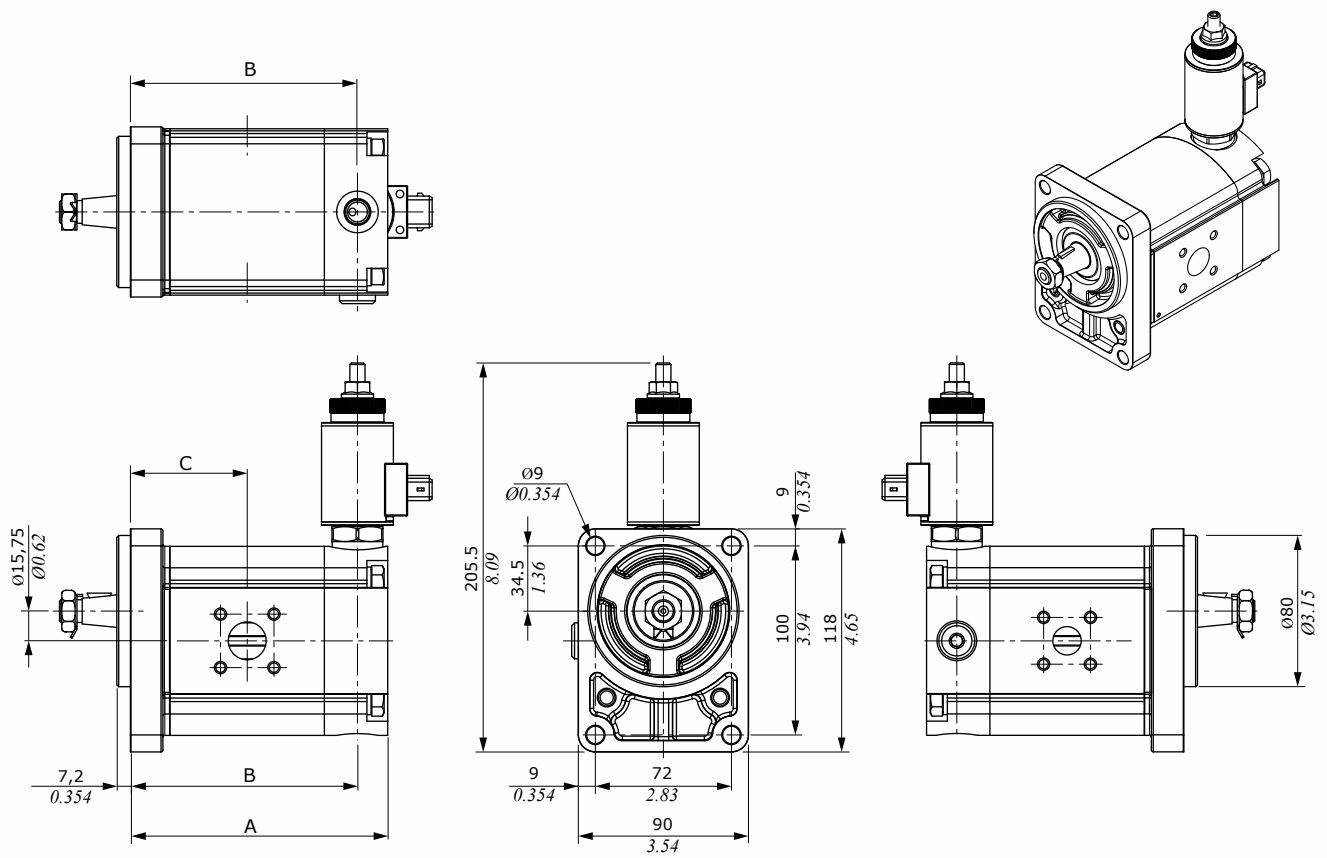

GROUP 2SM	A		B		C	
	mm	in	mm	in	mm	in
2SM 040	105.3	4.145	89.3	3.52	46.4	1.827
2SM 060	108.6	4.276	92.6	3.646	48.05	1.892
2SM 080	112.8	4.441	96.8	3.811	50.15	1.974
2SM 110	116.9	4.602	100.9	3.972	52.2	2.055
2SF 140	121.9	4.799	105.9	4.169	54.7	2.153
2SF 160	126.1	4.965	110.1	4.335	56.8	2.236
2SF 190	131.1	5.161	115.1	4.531	59.3	2.335
2SF 220	136.1	5.358	120.1	4.728	61.8	2.433
2SF 260	141.9	5.587	125.9	4.957	64.7	2.547
2SF 310	150.3	5.917	134.3	5.287	68.9	2.712

NEW

Reversible Fan Drive system

Motor with a proportional pressure relief valve, and on/off four way valve and an anti-cavitation valve integrated in the rear cover. The ON-OFF valve is used to reverse the direction for the automatic cleaning of the radiator from dirt and debris in order to increase the cooling efficiency and to reduce maintenance needs.

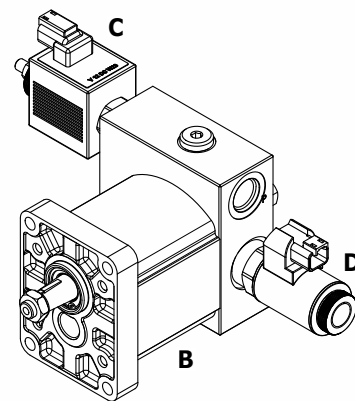
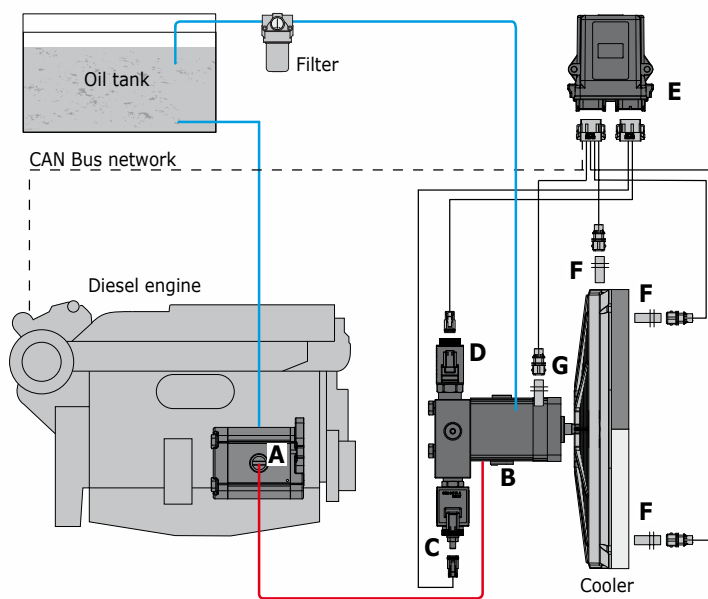

- A** Gear pump
- B** Gear motor
- C** Proportional pressure relief valve
- D** On/off reverse valve
- E** Electronic control unit
- F** Temperature sensor
- G** Speed sensor

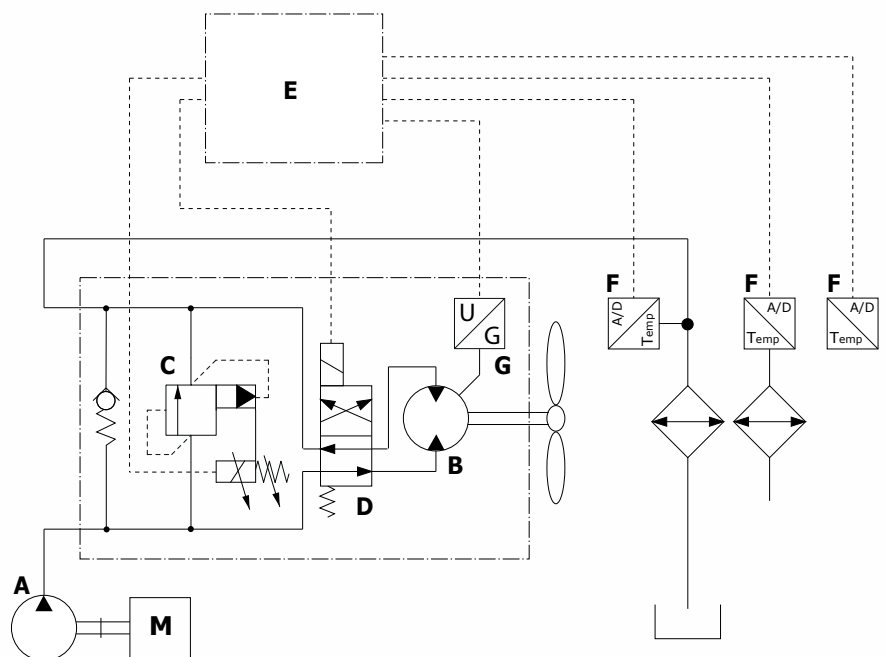
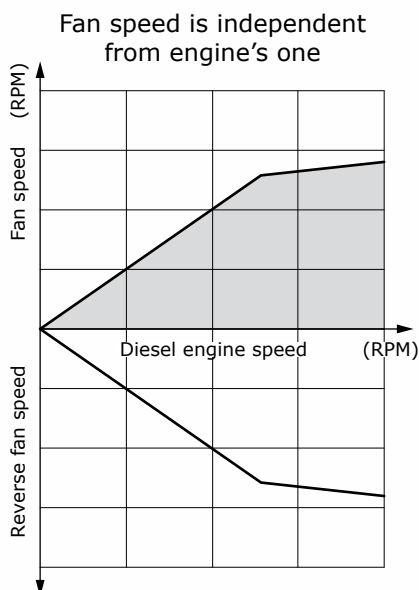

Fan Drive

Electrohydraulic Fan Drive Systems

Example of configurations

Example of 2 speeds Fan Drive configuration

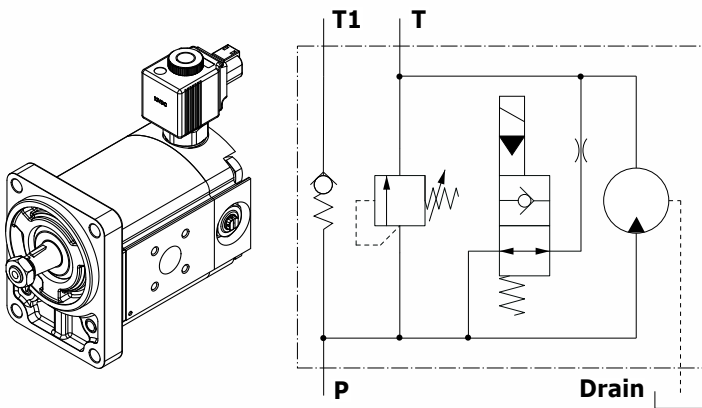

Example of Fan Drive configuration with speed sensor

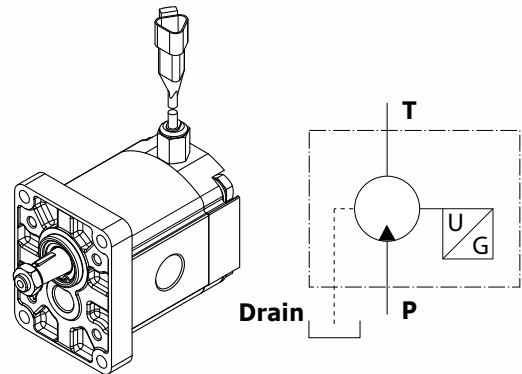

Outrigger bearing

Fan motors are suitable to work when axial loads are below 45 N - 101 lbf and radial loads below 90 N - 20.2 lbf. For higher loads special support flanges with outrigger bearings are available.

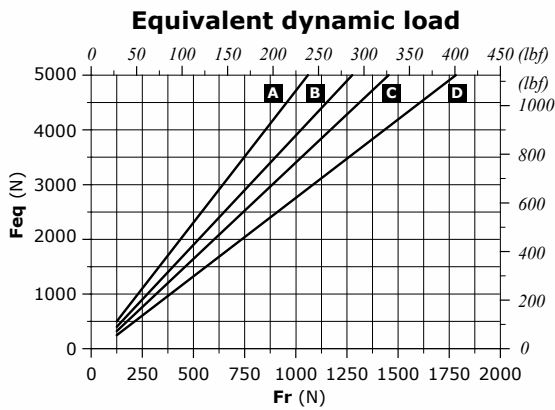

- A:** X = 40 mm - 1.57 in
- B:** X = 30 mm - 1.18 in
- C:** X = 20 mm - 0.79 in
- D:** X = 10 mm - 0.39 in

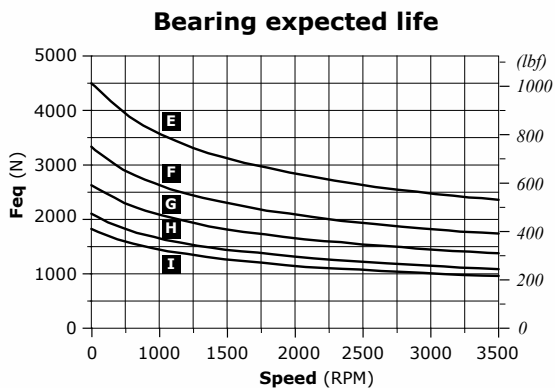
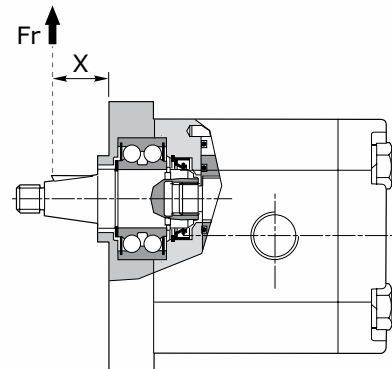

- E:** 1000 h
- F:** 2500 h
- G:** 5000 h
- H:** 10000 h
- I:** 15000 h

NEW

Accessories

W0403023

4AC0111900

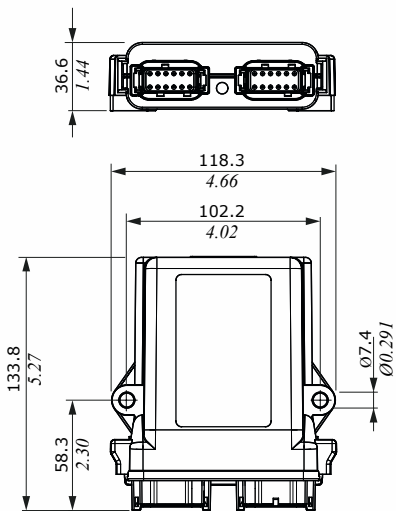
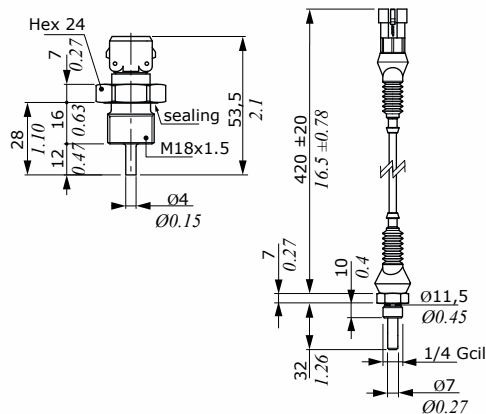

NOTE: The control unit must be ordered separately from the Fan Drive

Temperature sensor

Range of sensors specifically designed for this kind of applications. All the sensors can be used in air, water and oil. Different connector options.

GENERAL WORKING CONDITIONS		
Part number	W0403023	4AC0111900
Sensor type	NTC	NTC
Operating temperature	from -40 to +125 °C from -40 to +257 °F	from -20 to +105 °C from -5 to +221 °F
Resistance @25 °C (77 °F)	5000 Ohm	10000 Ohm
Environmental protection	IP67	IP67
Connector	AMP Junior Power Timer	AMP Superseal 1.5

CED400W Electronic control unit

Versatile electronic controller for Fan Drive applications, with high performance DSP microprocessor and SAE J1939 CAN Bus protocol. Cooling curves can be a combination of CAN data, temperature, pressure, RPM sensors. Retarder and reverse functions can be easily implemented. Standard behaviour can be graphically configured through **WST STUDIO** software. Custom applications can be developed through the **PHC STUDIO** (IDE - Integrated Development Environment) according to IEC 61139 standard.

GENERAL WORKING CONDITIONS		
Supply voltage		from 8 to 32 V
Max. current output	@ 12 VDC	6 A
Working temperature		from -40 to +85 °C from -40 to +185 °F
Environmental compatibility		EC60068-2-6/27/29
EMC compatibility		
Weather protection	with mating connector attached	IP67
Inputs	Analog	up to 4
	Digital	up to 6
Outputs	Proportional	2 (2A max)
	On/Off	2 (2A max)

For further specifications please see D1WWEE01E catalogue



PHC STUDIO

PHC Studio is an Integrated Development Environment (IDE) to develop and download into the CED400W electronic control unit the Custom application logics and Working parameters. PHC Studio allow to have the complete control of the application, either hydraulic that electronic. It is compliant with all the 5 programming languages of the IEC 61131-3 PLC Standard.



Description composition

2SM - G - 140 - D - EUR - H - N - 10 - 0 - G - PROP 4PD(300) - REV 4PD(.....) - SPS 4PD(300) - VA
1 2 3 4 5 6 7 8 9 10 11 13 11 13 12 13 14
- - .. - ... - 12VDC
15 16

Reference	Type	Description
1	Motor type	2SM = Group 2 motor
2	Flange and cover material	A = Aluminium / G = Cast iron
3	Displacement	From 040 (4 cm ³ /rev - 0.40 in ³ /rev) to 310 (31.5 cm ³ /rev - 1.92 in ³ /rev)
4	Rotation direction	D = Clockwise rotation S = Anticlockwise rotation R(D) = Reversible with clockwise rotation control R(S) = Reversible with anticlockwise rotation control
5	Flange type	EUR = European standard flange / SUPEUR = European flange for axial and radial loads SAEA = SAE standard flange B80C = German type standard flange B50C = E52C =
6	Seal ring type	A = without seal ring / H = for pressure up to 8 bar - 116 psi K = for pressure up to 30 bar - 435 psi / W = for pressure up to 100 bar - 1450 psi
7	Seal type	N = NBR type / V = VITON type
8	Shaft type	see Gear pumps & motors catalogue, code D1WGEM01IE
9	Ports position	see Gear pumps & motors catalogue, code D1WGEM01IE
10	Ports type	see Gear pumps & motors catalogue, code D1WGEM01IE
11	Motor configuration	NA = 2 speed, clockwise rotation / NC = 2 speed, anticlockwise rotation PROP = Variable speed, with proportional pressure relief valve PROP - REV = Reversible type; with proportional pressure relief valve and rotation reverse valve
12	Speed sensor	SPS = Speed sensor
13	Connector type	4 PD (.....) where: 4 = connector type 0 = ISO (omitted in descriptions) / 2 = AMP-JPT / 3 = Deutsch DT06 / 4 = Deutsch DT06-2P 5 = Deutsch DT06-4P / 6 = Metri-Pack female / 7 = Metri-Pack male 8 = Weather-Pack female / 9 = Weather-Pack male PD = connector direction (only for integrated type) PD = perpendicular to valve axis PL = parallel to valve axis (.....) : cable length in mm, if present
14	Anticavitation valve	VA = Anticavitation valve
15	Pressure relief valve (not for PROP configuration)	VLPI - N - 120 = With internal drain / VLPE - N - 120 = With external drain where: N = spring type / 120 = setting; see Gear pumps & motors catalogue, code D1WGEM01IE
16	Voltage	12VDC / 24VDC



D1WGCM02E - 2st edition March 2019

