

E-TRAC™ Drive Systems

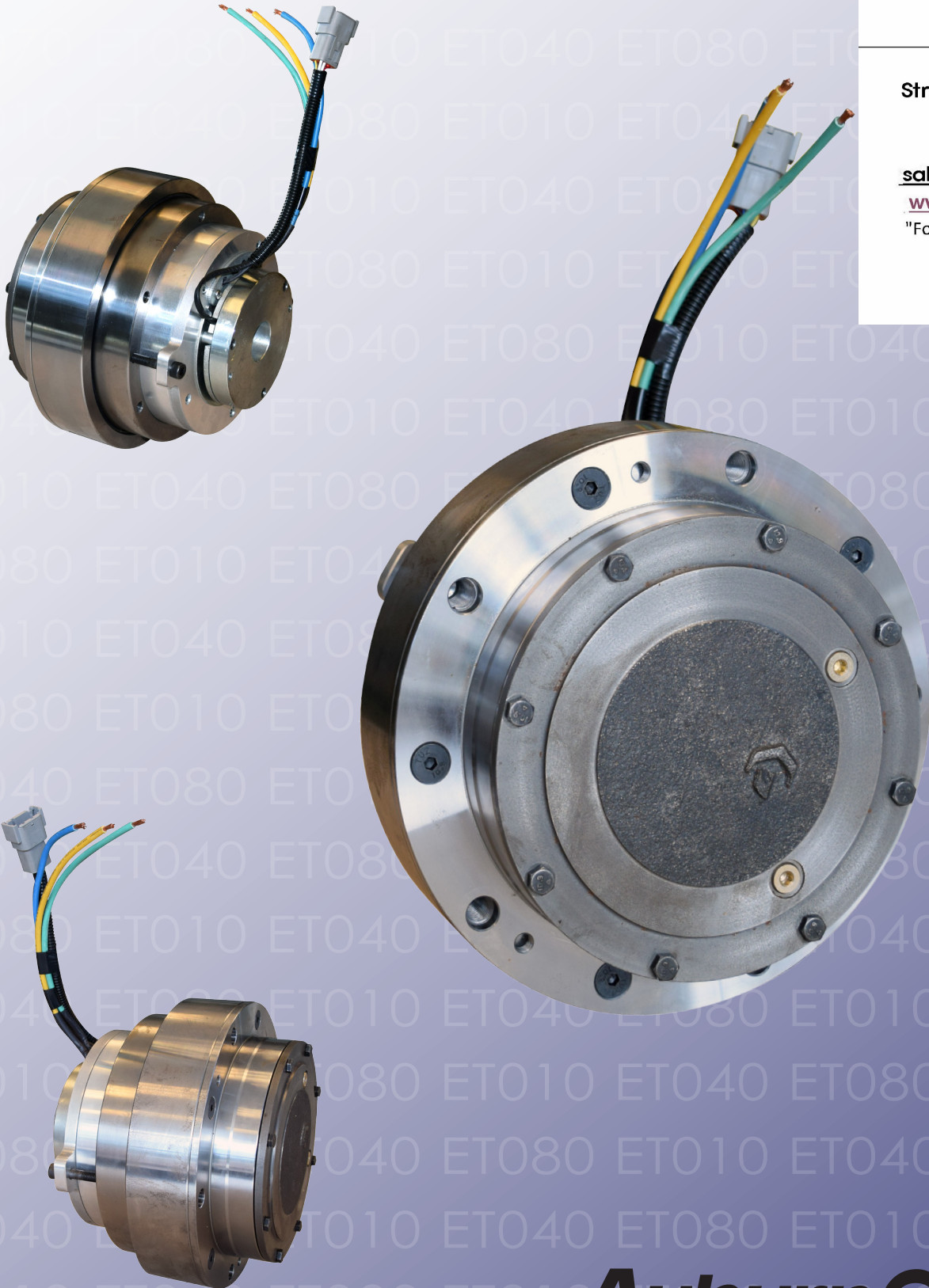

OIL SOLUTIONS

PO Box 38
Strathfieldsaye, VIC, 3551
1800 OIL SOL
1800 645 765
sales@oilsolutions.com.au
www.oilsolutions.com.au
"For All Your Hydraulic Needs"



Auburn Gear

E-TRAC™ ET010 Drive System

GENERAL SPECIFICATIONS

Max. Intermittent Output Torque..... 10,000 lb-in
 Max Input Speed..... 5000 RPM
 Approximate Gearbox Weight..... 58 lbs
 Approximate Oil Capacity..... 10 oz

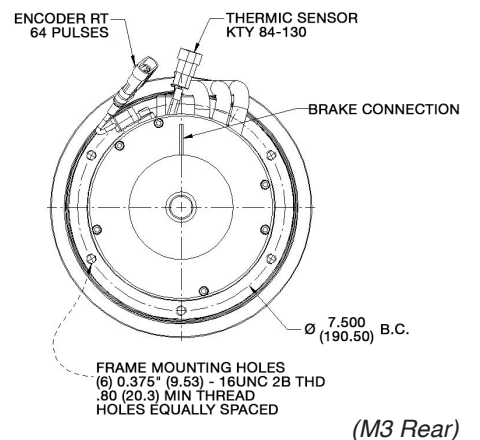
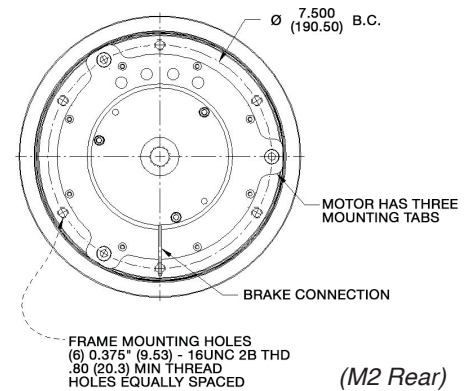
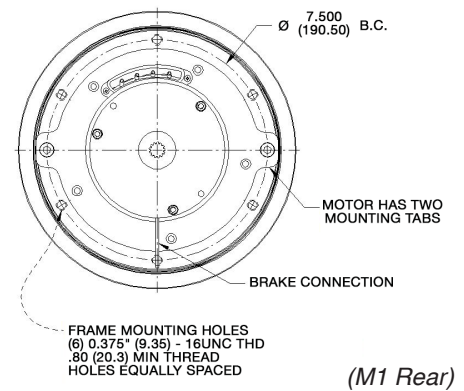
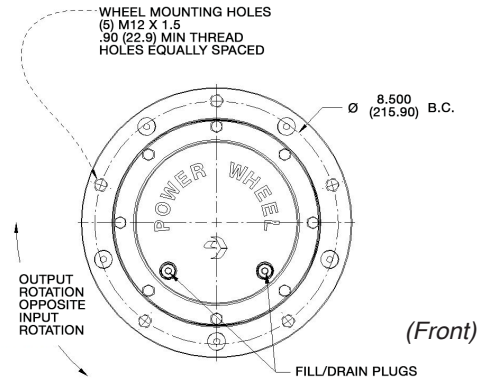
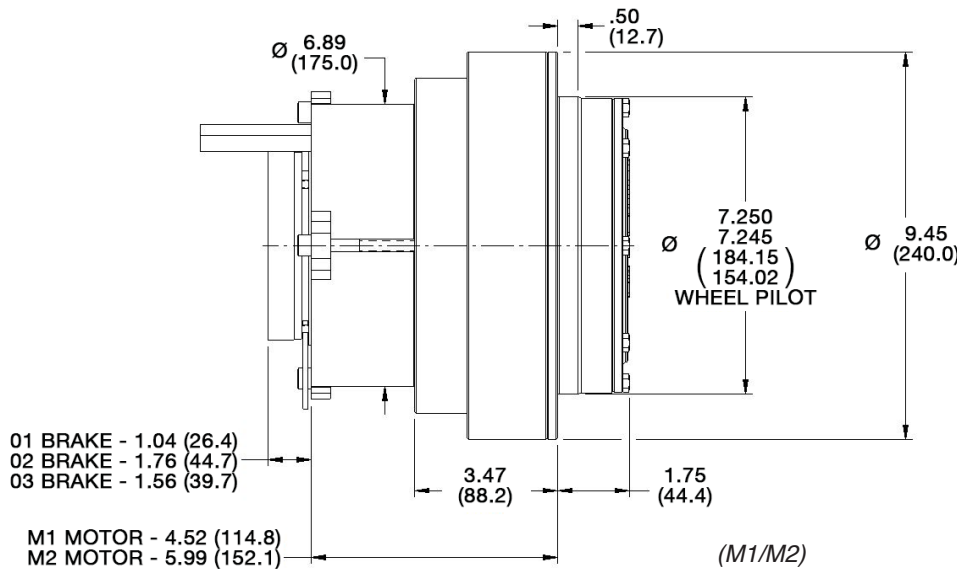

1800-OILSOL <https://oilsolutions.com.au/>
 1800-645765

sales@oilsolutions.com.au

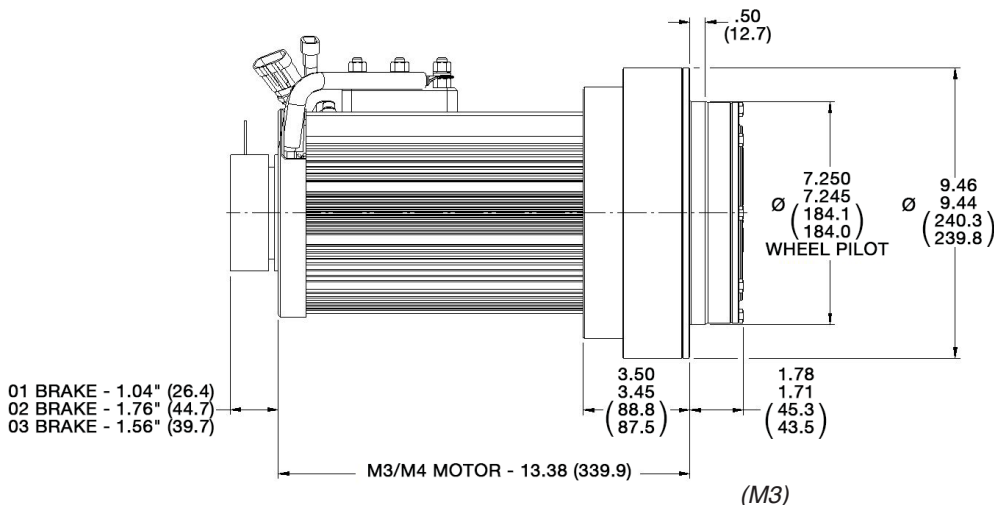

MOTOR	VOLTAGE	TORQUE LB-IN (Nm)	SPEED
M1	24V PMAC	24.8 (2.8)* 99.1 (11.2)^	2850 1200
M2	48V PMAC	83.2 (9.4)* 330.1 (37.3)^	5000 1200
M3	24V AC	147.9 (16.7)* 531.0 (60)^	2000 1000
M4	48V AC	147.9 (16.7)* 531.0 (60)^	2000 1000

*CONTINUOUS RATING; INDICATES S2-60MIN THERMAL RATING
^ PEAK RATING; INDICATES S2-2MIN THERMAL RATING

RATIOS
049 = 49.08:1
030 = 30.89:1
025 = 25.09:1

CONTROLLER
01 = NONE
Open Controller

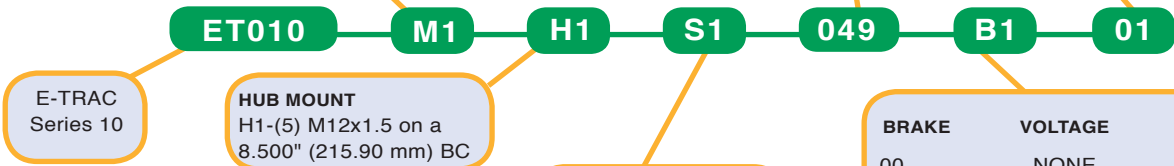

BRAKE	VOLTAGE	STATIC HOLDING TORQUE LB-IN (Nm)
00	NONE	X
B1	24V	88 (10)
B2	24V with Manual Release	88 (10)
B3	24V	185 (21)

ET010 VARIATIONS

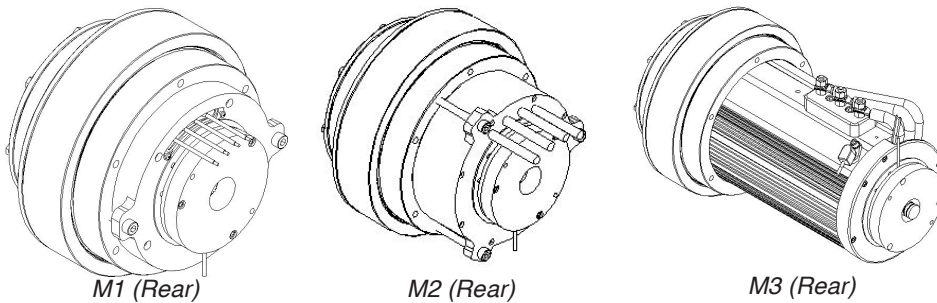

ET010 APPLICATIONS AND TARGET MARKETS

AERIAL WORK PLATFORMS

- Scissor Lifts
- Stock Pickers

COMMERCIAL TURF EQUIPMENT

- Mowers
- Sprayers

GROUND SUPPORT EQUIPMENT

- Tugs
- Helicopter Dollies

LIGHT CONSTRUCTION

- Floor Scrapers
- Floor Scrubbers

INDUSTRIAL EQUIPMENT

- Automated Guided Vehicles

BEARING CURVE

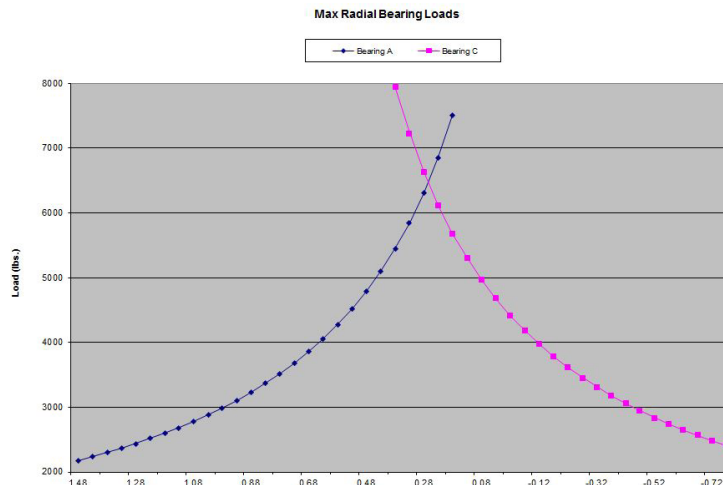

E-TRAC™ ET040 Drive System

GENERAL SPECIFICATIONS

Max. Intermittent Output Torque.....40,000 lb-in
 Max Input Speed..... 5000 RPM
 Approximate Gearbox Weight.....85 lbs
 Approximate Oil Capacity..... 27 oz

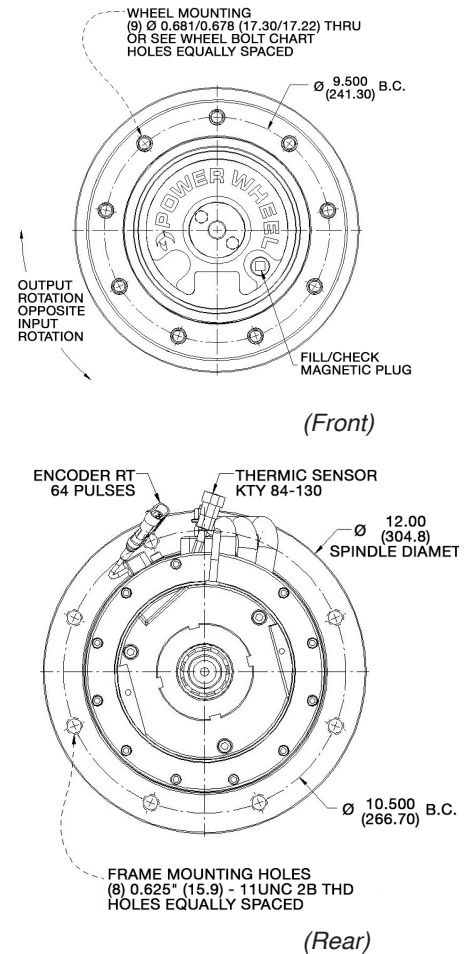
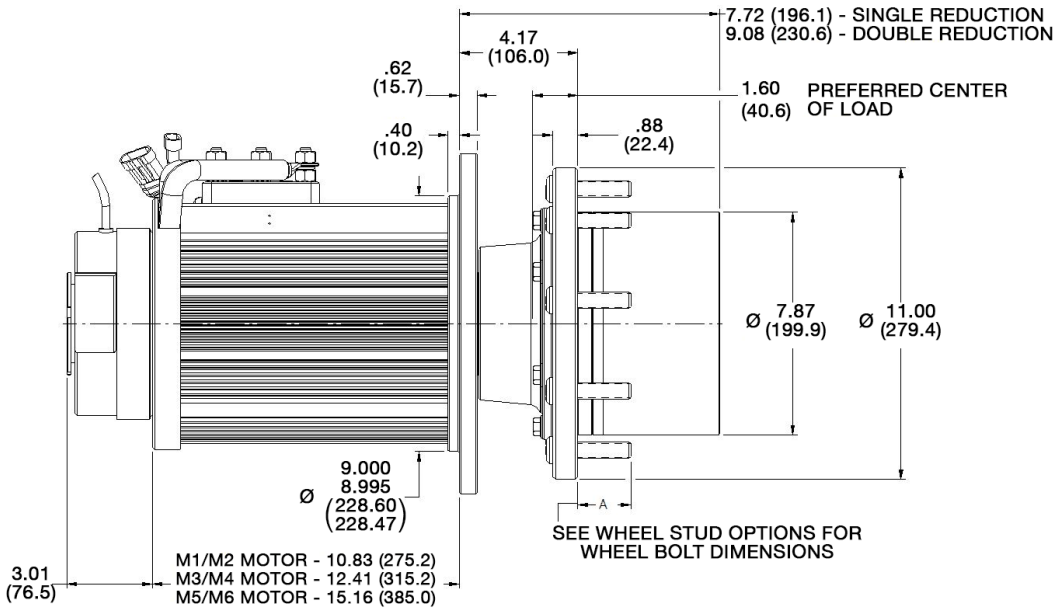

MOTOR	VOLTAGE	TORQUE LB-IN (Nm)	SPEED
M1	48V AC	253.1 (28.6)*	2000
		471.7^	1200
M2	80V AC	253.1 (28.6)*	2000
		471.7^	1000
M3	48V AC	338.1 (38.2)*	2000
		938.2^	1000
M4	80V AC	338.1 (38.2)*	2000
		938.2^	1000
M5	48V AC	422.6*	2000
		1419.6^	1000

*CONTINUOUS RATING; INDICATES S2-60MIN THERMAL RATING
 ^ PEAK RATING; INDICATES S2-2MIN THERMAL RATING

RATIOS

014=14.30:1	032=32.79:1
015=15.88:1	037=37.55:1
017=17.95:1	046=46.74:1
020=20.80:1	051=51.65:1
022=22.72:1	058=58.12:1
025=25.16:1	067=67.01:1
028=28.37:1	

BRAKE	VOLTAGE	STATIC HOLDING TORQUE LB-IN (Nm)
00	NONE	X
B1	24V	531 (60)



E-TRAC Series 40

HUB MOUNT
 H1-(9) Wheel Studs on 9.50" (241.3) BC

FRAME MOUNTING
 S1-(6) 5/8-16UNC on a 10.500" (266.70) BC
 Pilot - 9.00/8.995 (228.60/228.47)

WHEEL STUDS
 00=None, 0.681/0.678 (17.30/17.22)
 01=1/2-20 UNF-2A x 1.62 (41.1)
 02=5/8-18 UNF-2A x 1.48 (37.6)
 03=9/16-18 UNF-2A x 1.87 (47.5)
 04=M16 x 1.5-6g x 2.10 (53.5)
 05=M18 x 1.5-6g x 1.91 (48.5)

CONTROLLER
 01 = NONE
 Open Controller

ET040 VARIATIONS

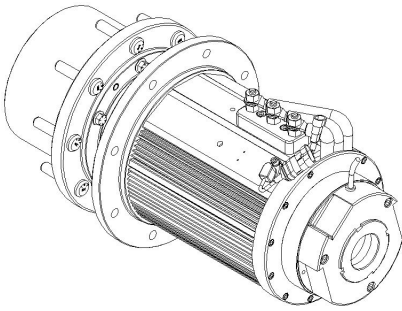

(Rear ISO)

ET040 APPLICATIONS AND TARGET MARKETS

GROUND SUPPORT EQUIPMENT

- Tugs
- Belt Loaders

LIGHT CONSTRUCTION

- Piggyback Forklifts

INDUSTRIAL EQUIPMENT

- Automated Guided Vehicles

SPECIALTY AGRICULTURE

- Augers and Traction Drives



1800-OILSOL
1800-645765

<https://oilsolutions.com.au/>

sales@oilsolutions.com.au

BEARING CURVE

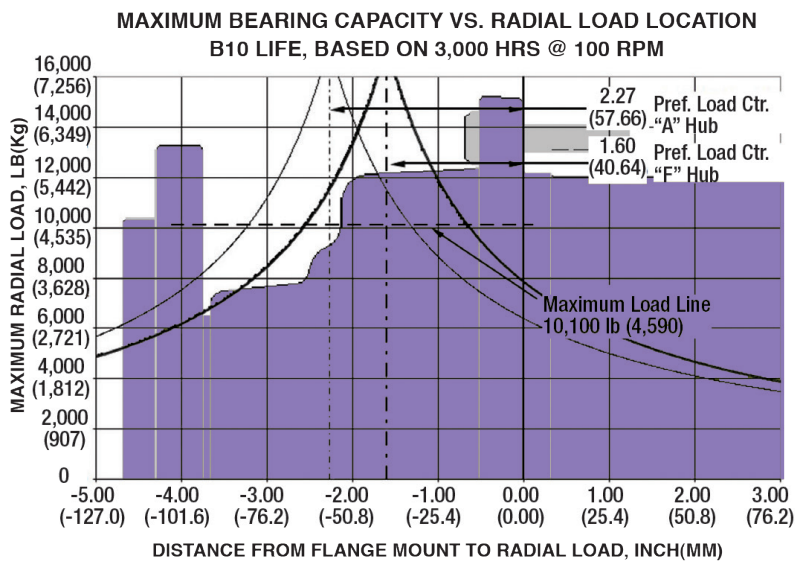

E-TRAC™ ET070 Drive System

GENERAL SPECIFICATIONS

Max. Intermittent Output Torque..... 70,000 lb-in
 Max Input Speed..... 5000 RPM
 Approximate Gearbox Weight..... 125 lbs
 Approximate Oil Capacity..... 35 oz

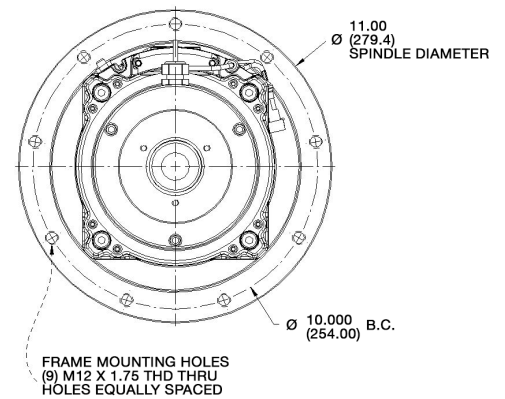
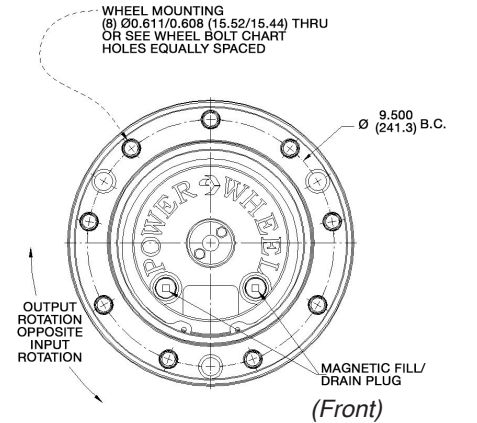
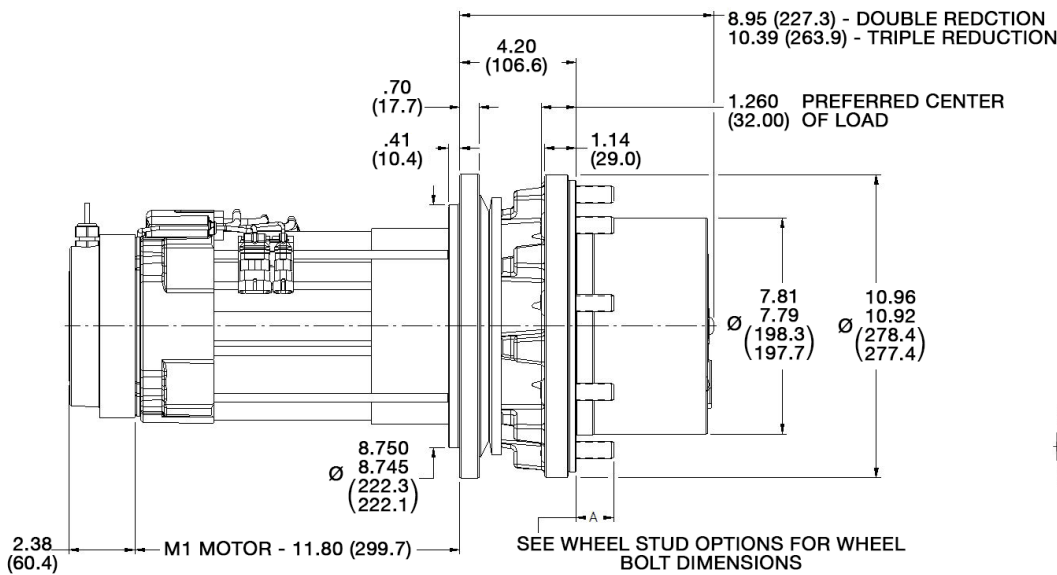

(Rear)



1800-OILSOL
1800-645765

<https://oilsolutions.com.au/>

sales@oilsolutions.com.au

RATIOS		TRIPLE REDUCTIONS		
014=14.30:1		080=80.70:1		
017=17.94:1		081=87.89:1	136=136.72:1	253=253.91:1
022=22.71:1	037=37.52:1	097=97.04:1	150=150.90:1	276=276.35:1
025=25.15:1	046=46.74:1	100=100.00:1	169=169.47:1	304=304.90:1
028=28.27:1	058=50.09:1	109=109.03:1	195=195.12:1	342=342.28:1
032=32.79:1	066=66.98:1	125=125.59:1	220=220.57:1	393=393.35:1

MOTOR	VOLTAGE	TORQUE LB-IN (Nm)	SPEED
M1	24V AC	147.3 (16.6)* 168.2 (19.0)^	2000 1200

*CONTINUOUS RATING; INDICATES S2-60MIN THERMAL RATING
 ^ PEAK RATING; INDICATES S2-2MIN THERMAL RATING

WHEEL STUDS

00=None, 0.681/0.678 (17.30/17.22)
 01=1/2-20 UNF-2A x 1.50 (38.1)
 02=5/8-18 UNF-2A x 1.38 (35.1)
 03=9/16-18 UNF-2A x 1.70 (43.2)
 04=M16 x 1.5-6g x 50
 05=M18 x 1.5-6g x 45

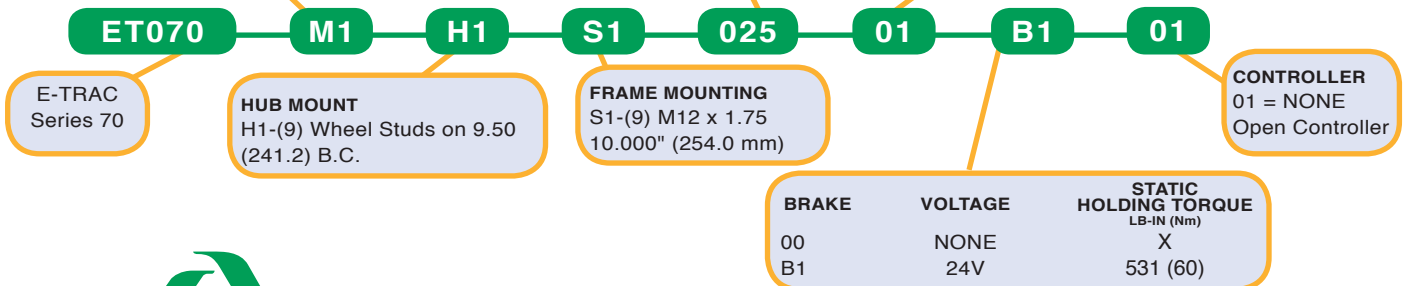

ET070 VARIATIONS

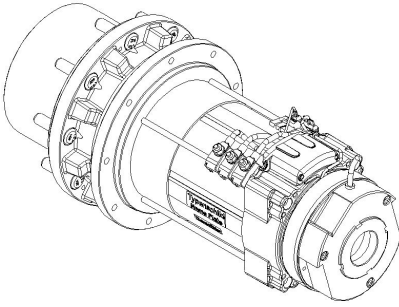

(Rear ISO)

ET070 APPLICATIONS AND TARGET MARKETS

AERIAL WORK PLATFORMS

- Boom Lifts

GROUND SUPPORT EQUIPMENT

- Tugs
- Push-backs

INDUSTRIAL EQUIPMENT

- Automated Guided Vehicles

SPECIALTY AGRICULTURE

- Harvesters



1800-OILSOL
1800-645765

<https://oilsolutions.com.au/>

sales@oilsolutions.com.au

BEARING CURVE AND MOTOR CURVE

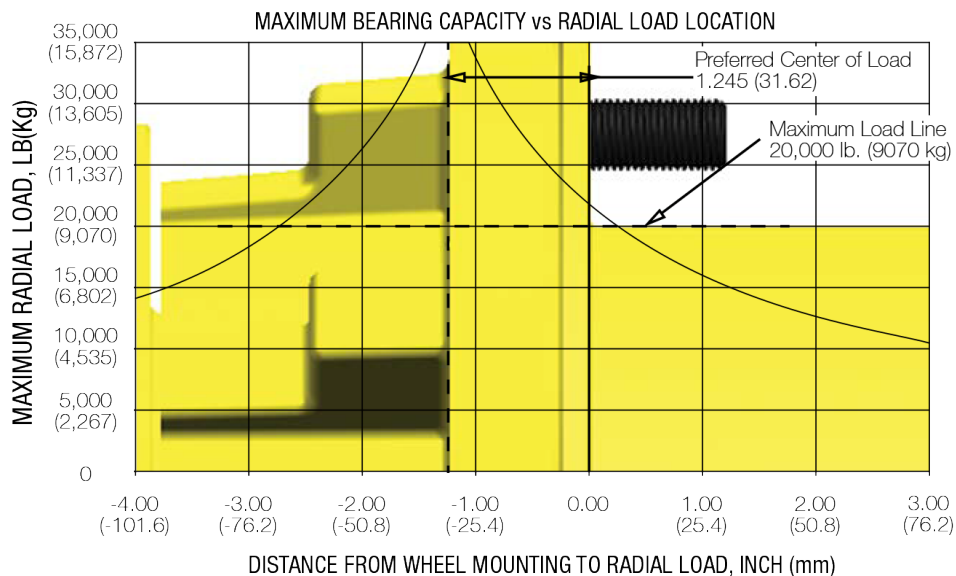

E-TRAC™ ET080 Drive System

GENERAL SPECIFICATIONS

Max. Intermittent Output Torque..... 100,000 lb-in
 Max Input Speed..... 5000 RPM
 Approximate Gearbox Weight..... 208 lbs
 Approximate Oil Capacity..... 57 oz

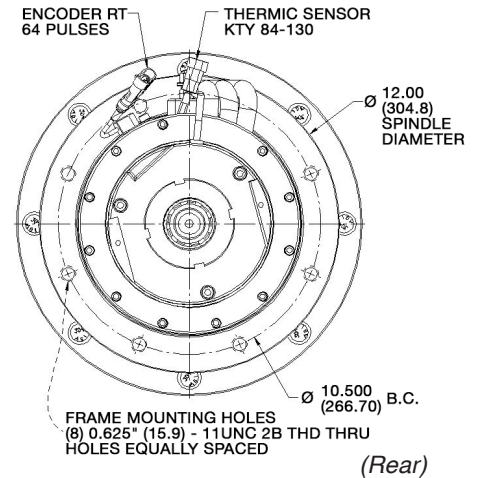
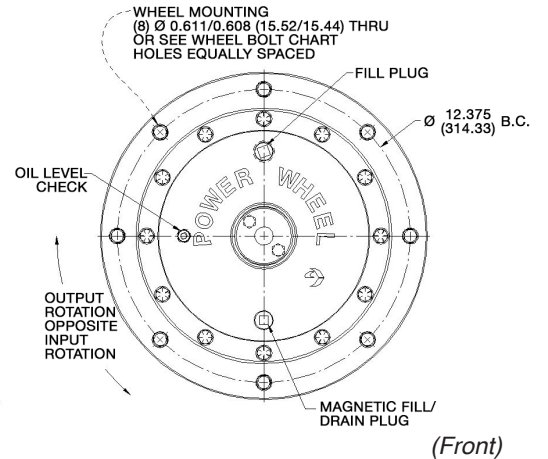
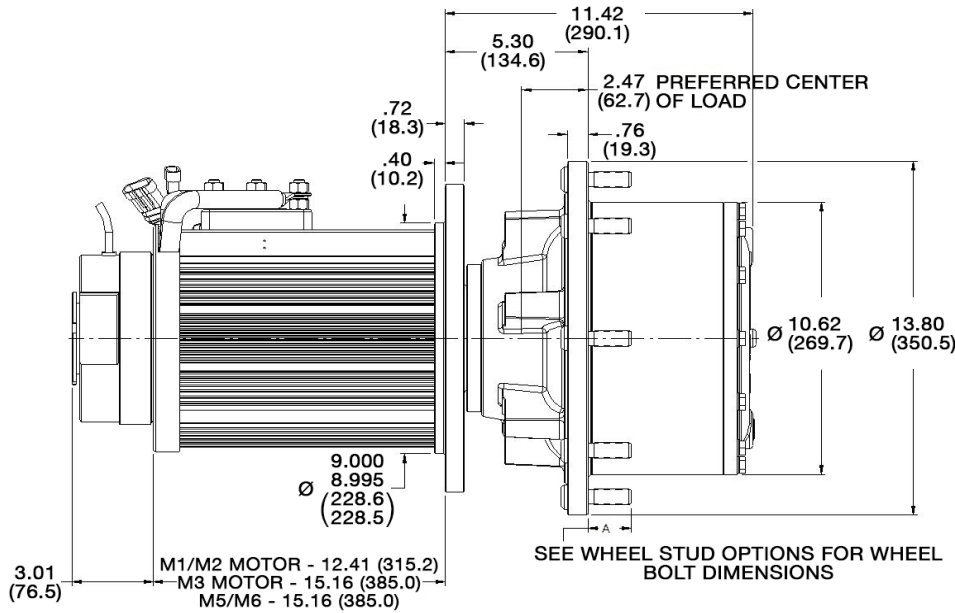

1800-OILSOL <https://oilsolutions.com.au/>
 1800-645765

sales@oilsolutions.com.au

MOTOR	VOLTAGE	TORQUE LB-IN (Nm)	SPEED
M1	48V AC	338.1 (38.2)*	2000
		938.2 (106.0)^	1200
M2	80V AC	338.1 (38.2)*	2000
		938.2 (106.0)^	1000
M3	48V AC	422.6 (47.8)*	2000
		1419.6 (160.4)^	1000
M4	80V AC	507.1 (57.3)*	2000
		1957.8 (221.2)^	1000
M5	96V AC	507.1 (57.3)*	2000
		1957.8 (221.2)^	1000

*CONTINUOUS RATING; INDICATES S2-60MIN THERMAL RATING
 ^ PEAK RATING; INDICATES S2-2MIN THERMAL RATING

RATIOS

014=14.39:1
017=17.83:1
022=22.59:1
025=25.71:1
030=30.50:1
034=34.20:1
041=41.42:1
049=49.00:1

WHEEL STUDS

00=None, 0.611/0.608 (15.52/15.44)
01=1/2-20 UNF-2A x 1.74 (44.2)
02=5/8-18 UNF-2A x 1.99 (50.5)
03=9/16-18 UNF-2A x 1.6 (40.6)
04=M16 x 2.0-6g x 50

CONTROLLER
 01 = NONE
 Open Controller

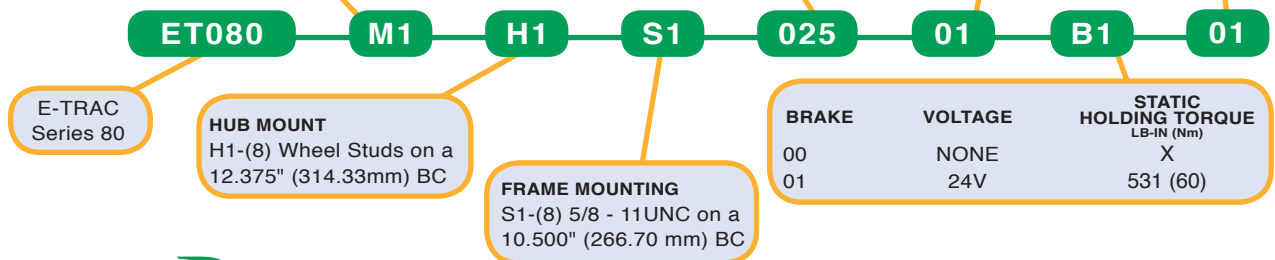

ET080 VARIATIONS

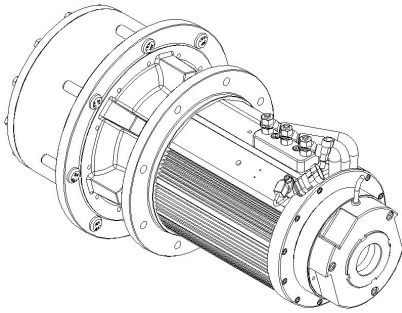

(Rear ISO)

ET080 APPLICATIONS AND TARGET MARKETS

CONSTRUCTION

- Puller/Tensioners

GROUND SUPPORT EQUIPMENT

- Tugs

COMMERCIAL EQUIPMENT

- People Movers



1800-OILSOL <https://oilsolutions.com.au/>
1800-645765

sales@oilsolutions.com.au

BEARING CURVE AND MOTOR CURVE

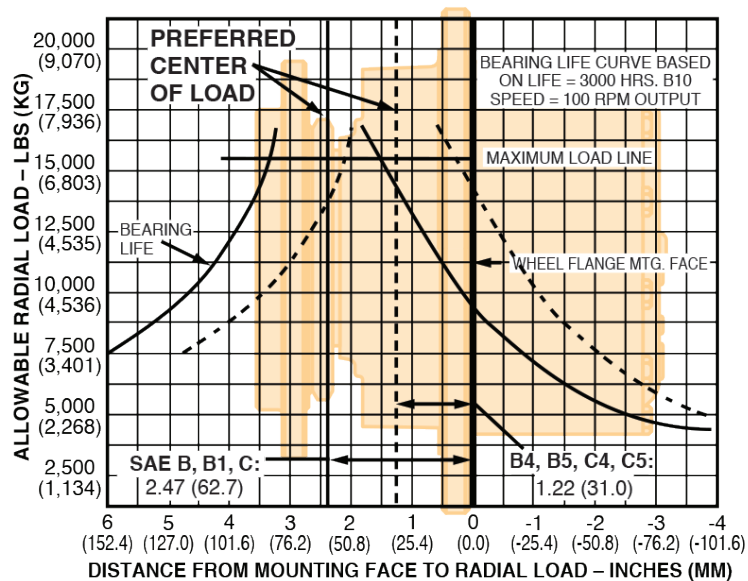

Providing Technology, Quality, & Customer Support Around the Globe



*All specifications and data contained herein are nominal and subject to change without notice.
Specific applications should be referred to Auburn Gear for current information.*



1800-OILSOL
1800-645765

<https://oilsolutions.com.au/>

sales@oilsolutions.com.au



400 E. Auburn Drive | Auburn, IN 46706

260.925.3200

www.AuburnGear.com