

Power Wheel®
Model 8 Series B Planetary Gear Drives



SERIES B WHEEL DRIVES

Model 8 Series B Features & A2 Integral Brake Information.....3
 Double Reduction.....4
 with A2 Series Integral Parking Brake.....6
 with N-Series Fully Integrated Parking Brake.....8

SERIES B – SHAFT & FLANGED OUTPUT DRIVES

Single & Double Reduction.....10
 with A2 Series Integral Parking Brake.....12

SERIES B – SHAFT INPUT/SHAFT & FLANGED OUTPUT DRIVES

Double Reduction.....14

MODEL 8 SERIES B OPTIONS

Model 8 Series B Shaft & Flanged Output Options.....16

OTHER OPTIONS.....17

INFORMATION

Lubrication Data.....18
 Warranty.....19



1800-OILSOL <https://oilsolutions.com.au/>
 1800-645765

sales@oilsolutions.com.au

Power Wheel® Model 8 Series B Features

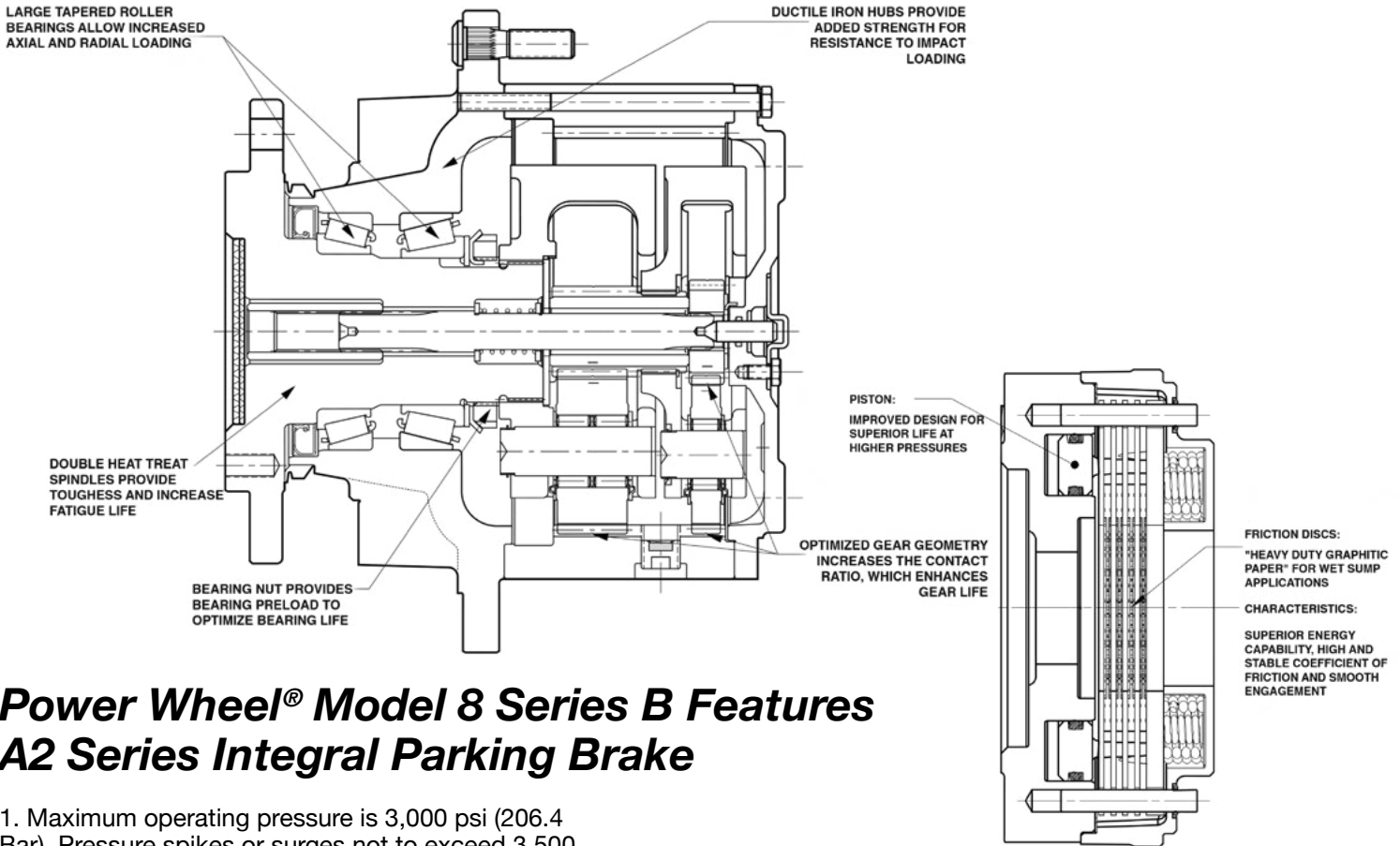

Power Wheel® Model 8 Series B Features A2 Series Integral Parking Brake

1. Maximum operating pressure is 3,000 psi (206.4 Bar). Pressure spikes or surges not to exceed 3,500 psi (240.8 Bar). Surge pressure in excess of 3,500 psi (240.8 Bar) caused by spikes in the hydraulic system could shorten brake life and must be avoided.

2. Use only SAE grade 8 mounting bolts and torque to 80-90 lb. ft (108 - 122 N-m) for motor mounting.

3. **PRECAUTION:** Bench testing may cause distortion of components or bolt failure. Mounting bolts must be used or supplemental clamping.

4. Minimum Release Pressure is defined as the hydraulic pressure required to obtain full running clearance.

5. Cubic Inch Displacement is the volume of oil required to release the brake piston.

1.0 in³ (16.4cc) for a new brake and 2.0 in³ (32.8cc) for a worn brake pack—**SAE A, B**

0.7 in³ (11.5cc) for a new brake and 1.6 in³ (26.2cc) for a worn brake pack—**SAE C**

BRAKE RATINGS

MOUNT	MODEL	TORQUE	MIN. RELEASE PRESSURE	STYLE
SAE A, B	B2	1,800 lb-in (203 N-m)	220 PSI (15.1 Bar)	Short
SAE A, B	B3	2,400 lb-in (271 N-m)	290 PSI (20.0 Bar)	Short
SAE B	B4	2,400 lb-in (271 N-m)	160 PSI (11.0 Bar)	Long
SAE A, B	B5	3,200 lb-in (362 N-m)	220 PSI (15.1 Bar)	Long
SAE B	B6	3,600 lb-in (407 N-m)	230 PSI (15.8 Bar)	Long
SAE A, B	B7	4,200 lb-in (475 N-m)	260 PSI (17.9 Bar)	Long
SAE C	B4	2,400 lb-in (271 N-m)	135 PSI (09.3 Bar)	—
SAE C	B6	3,600 lb-in (407 N-m)	185 PSI (12.4 Bar)	—
SAE C	B7	4,200 lb-in (475 N-m)	210 PSI (14.5 Bar)	—

NOTE:

The data presented in this catalog is for general information and preliminary layout purposes only. Auburn Gear, through its policy of continual improvement, reserves the right to update its products; therefore, the information presented is subject to change. For specific application and/or dimensional information, contact Auburn Gear.

GENERAL SPECIFICATIONS

Max. intermittent output torque^{1,2}.....100,000 lb-in (11,300 Nm)
 Max. input speed².....5,000 RPM

Approximate Weight.....208 lbs (94 kg)
 Oil Capacity.....57 oz (1.685 ml)

For Lubrication Data, See Page 18

¹ Depending on the duty cycle and the nature of the application, a normal continuous output torque of 1/3 to 1/2 of the maximum intermittent should yield satisfactory Power Wheel life. Customer testing and application analysis is strongly recommended.
² If application exceeds published limits, contact Auburn Gear.

Dimensions given in: INCHES (mm)

SAE B, B6, C

(Motor Mounting Holes 22.5° offset from spindle mounting holes as shown)
 (B6 Motor Mounting Holes in-line with spindle mounting holes)

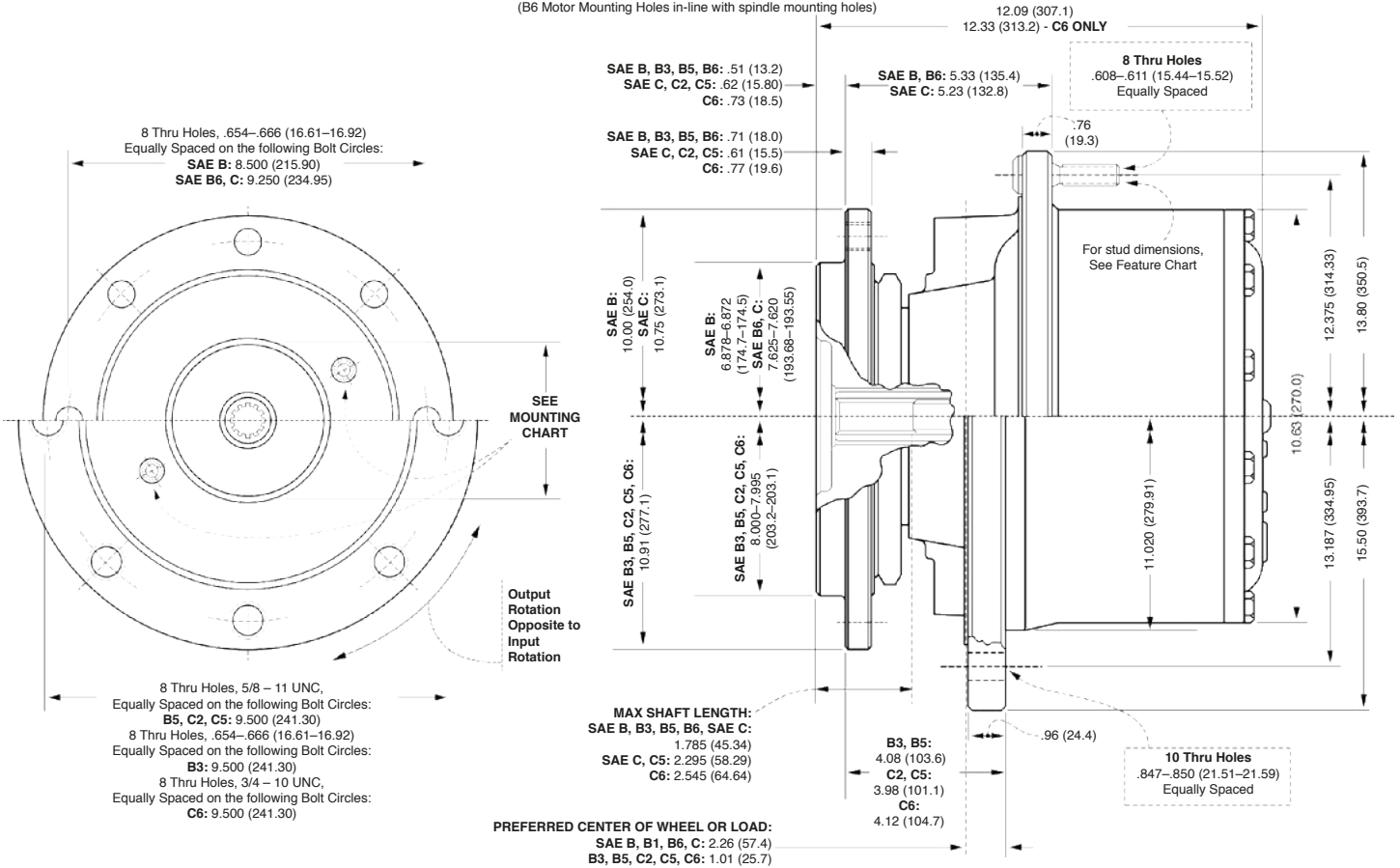

NON-POWERED UNITS ARE ALSO AVAILABLE

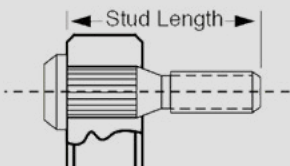

Wheel Stud – Detail

Note that the stud lengths shown in the feature chart represent the total length of the stud under the head.

Model 8 Series B Wheel Drives • Double Reduction

FEATURE CHART: Model 8 Series B Wheel Drives Double Reduction

OPTIONS	DESCRIPTION	MAKE ALL SELECTIONS WITHIN ONE COLUMN		ORDER CODES	USE OPTION ORDER CODES TO BUILD ORDER NUMBER	
MOTOR PILOT/HUB	SAE B	•	•	8W2B	8W2B	
	B3	•	•	8W2B3		
	B5	•		8W2B5		
	B6	•		8W2B6		
	SAE C			8W2C		
	C2			8W2C2		
	C5			8W2C5		
	C6			8W2C6		
INPUT SPLINE	13T - 16/32	•		13	13	
	14T - 12/24	•	•	14		
	15T - 16/32	•		15		
RATIO OPTIONS	14.39:1	•	•	14	34	
	17.83:1	•	•	17		
	22.59:1	•	•	22		
	25.71:1	•	•	25		
	30.50:1	•	•	30		
	34.20:1	•	•	34		
	37.89:1	•	•	37		
	41.42:1	•	•	41		
49.00:1	•	•	49			
WHEEL STUDS	1/2" x 2.50	•	•	5	8	
	9/16" x 2.75	•	•	7		
	5/8" x 2.37	•	•	8		
	3/4" x 3.21*	•	•	11		
	NONE	•	•	0		
SPECIAL FEATURES	Brake Disc**	•	•	D	Z	
	Boot Seal	•	•	Z		
	Brake Disc Holes	•	•	DH		
	Quick Disconnect	•	•	Q		
	Oil Plugs/Spindle Side	•	•	P		
	High Strength Carrier	•	•	Y		
	Cartridge Seal	•	•	T		

Select desired characteristics from chart, note correct order codes, and order using sample format shown at right: **8W2B 13 34 8 Z**

* Available with B5 and C5 mounting only ** Customer supplied, Auburn Gear assembled

MOTOR MOUNTING CHART

MOTOR MOUNTING HOLE DIMENSIONS	DIAMETER
SAE B, B3, B5, B6: (2) - 1/2" -13 UNC 2B Thd Holes on 5.750 (146.0) 5B. C.	Ø 4.001 - 4.006 (101.62 - 101.75)
SAE C, C6: (4) - 1/2" -13 UNC 2B Thd Holes on 6.375 (161.93) B. C.	Ø 5.001 - 5.006 (127.02 - 127.15)
C2: (2) - 5/8" -11 UNC 2B Thd Holes on 7.125 (180.98) B.	Ø 5.001 - 5.006 (127.02 - 127.15)
C5: (4) - 1/2" -13 UNC 2B Thd Holes on 6.375 (161.93) B. C. AND (2) -5/8" -11 UNC 2B Thd Holes on 7.125 (180.98) B. C.	Ø 5.001 - 5.006 (127.02 - 127.15)

+ "O" RING OR GASKET REQUIRED (Not Supplied by Auburn Gear)
"O" RING SIZES: SAE "B" 2-155 (614120), SAE "C" 2-159 (614136)

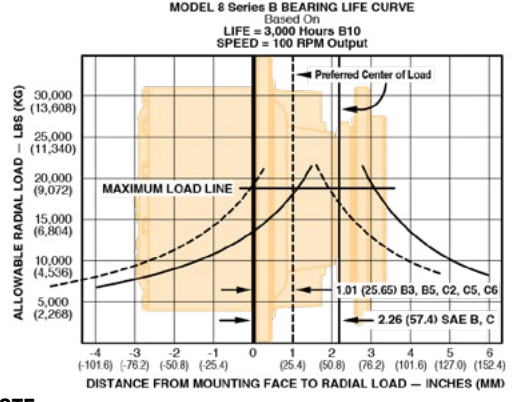

NOTE: These curves are supplied as a design guide and apply to resultant radial load only. They indicate the importance of maintaining wheel position over the bearing center. For actual analysis, applications should be reviewed by Auburn Gear Engineering using data supplied on Application Data Form.

Bearing Load, Life, and Speed Relationships

$$LF = \frac{SF \times R}{R'}$$

R = Allowable resultant load or given location from mounting flange
R' = Anticipated load at location from mounting flange
LF = Life Factor from table (see Below)
SF = Speed Factor from Table (see Below)

OUTPUT SPEED (RPM)	SF	LF	BEARING HOURS B-10 LIFE
5	2.456	0.584	500
10	1.994	0.719	1000
20	1.620	0.812	1500
30	1.435	0.886	2000
40	1.316	0.947	2500
50	1.231	1.000	3000
60	1.165	1.047	3500
70	1.113	1.090	4000
80	1.069	1.130	4500
90	1.032	1.166	5000
100	1.000	1.231	6000
200	0.812	1.289	7000
300	0.719	1.342	8000
400	0.659	1.390	9000
500	0.617	1.435	10000

CAUTION: The same torsional loading constraints used in the driving mode must be used in the braking mode when braking through the Power Wheel drive gear set.

NOTE: The data presented in this catalog is for general information and preliminary layout purposes only. Auburn Gear, through its policy of continual improvement, reserves the right to update its products; therefore, the information presented is subject to change. For specific application and/or dimensional information, contact Auburn Gear.



1800-OILSOL
1800-645765

<https://oilsolutions.com.au/>

sales@oilsolutions.com.au



GENERAL SPECIFICATIONS

Max. intermittent output torque^{1,2}.....100,000 lb-in (11,300 Nm)
Max. input speed³.....4,000 RPM

Approximate Weight.....225 lbs (102 kg)
Oil Capacity.....62 oz (1,835 cc)

For Lubrication Data, See Page 18

¹ Depending on the duty cycle and the nature of the application, a normal continuous output torque of 1/3 to 1/2 of the maximum intermittent should yield satisfactory Power Wheel life. Customer testing and application analysis is strongly recommended.

² If application exceeds published limits, contact Auburn Gear.

³ For input speed above 4,000 RPM contact Auburn Gear for duty cycle analysis.

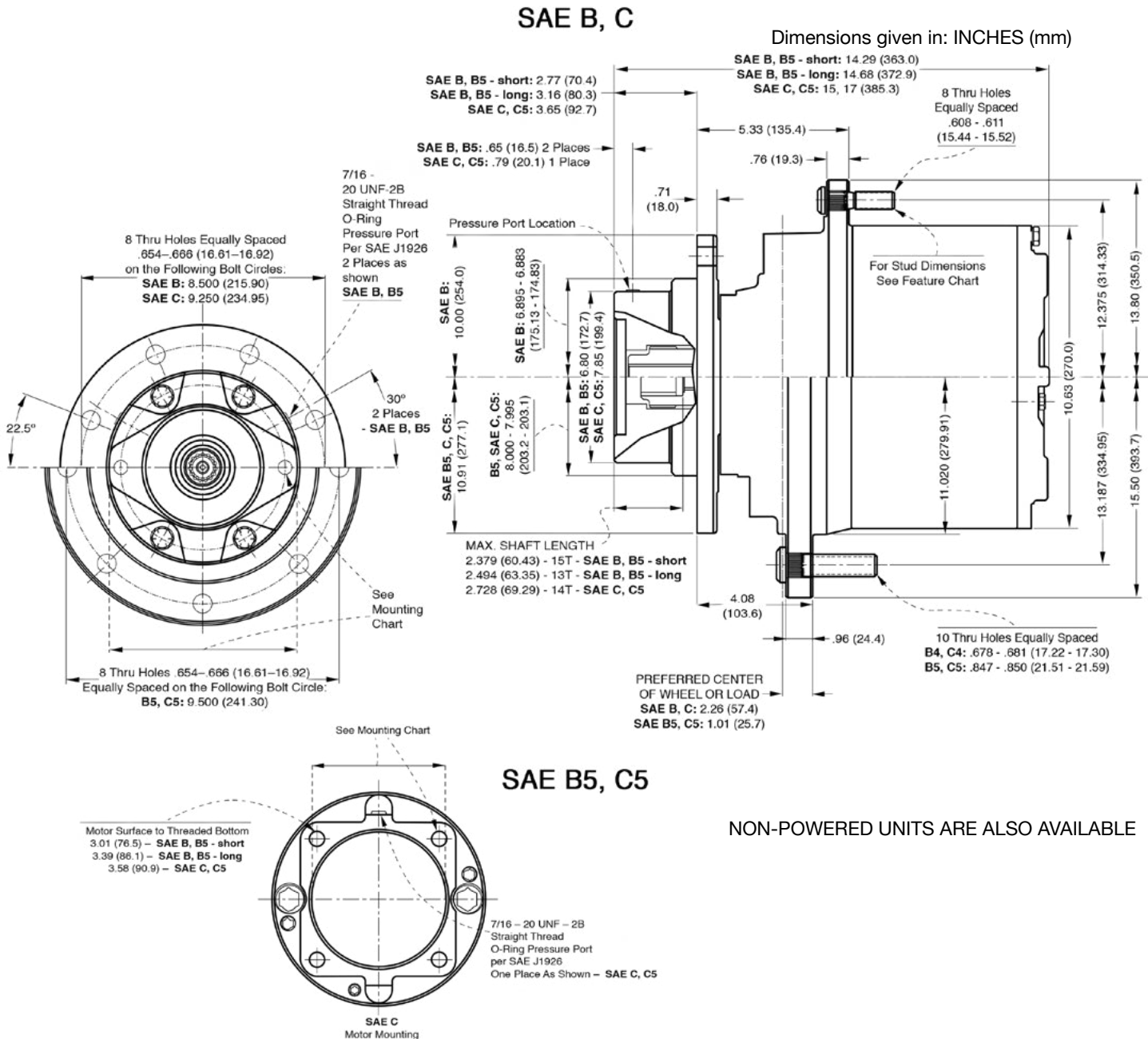

Model 8 Series B Wheel Drives with A2 Series Parking Brake

Model 8 Series B Wheel Drives • Double Reduction with A2 Series Integral Parking Brake

FEATURE CHART: Model 8 Series B Wheel Drives Double Reduction With Brake

OPTIONS	DESCRIPTION	MAKE ALL SELECTIONS WITHIN ONE COLUMN		ORDER CODES	USE OPTION ORDER CODES TO BUILD ORDER NUMBER			
MOTOR PILOT/HUB	SAE B B5 SAE C C5	•	•	8W2B 8W2B5 8W2C 8W2C5	8W2B5			
INPUT SPLINE	13T - ¹⁶ / ₃₂ 14T - ¹² / ₂₄ 15T - ¹⁶ / ₃₂	•	•	13 14 15	13			
RATIO OPTIONS	14.39:1 17.83:1 22.59:1 25.71:1 30.50:1 34.20:1 37.89:1 41.42:1 49.00:1	•	•	14 17 22 25 30 34 37 41 49	34			
WHEEL STUDS	¹ / ₂ " x 2.50 ⁹ / ₁₆ " x 2.75 ⁵ / ₈ " x 2.37 ³ / ₄ " x 3.21* NONE	•	•	5 7 8 11 0	8			
PARKING BRAKE	SHORT VERSION 1,800 lb-in 2,400 lb-in LONG VERSION 2,400 lb-in 3,200 lb-in 3,600 lb-in 4,200 lb-in	•	•	B2 B3 B4 B5 B6 B7	B5			
SPECIAL FEATURES	Brake Disc** Boot Seal Brake Disc Holes Quick Disconnect Oil Plugs/Spindle Side High Strength Carrier Cartridge Seal	•	•	D Z DH Q P Y T	Z			

Select desired characteristics from chart, note correct order codes, and order using sample format shown at right:

8W2B5 13 34 8 B5 Z

* Available with B5 and C5 mounting only

** Customer supplied, Auburn Gear assembled

MOTOR MOUNTING CHART

MOTOR MOUNTING HOLE DIMENSIONS	DIAMETER
SAE B, B5: (2) - ¹ / ₂ " -13 UNC 2B Thd Holes on 5.750 (146.0) 5B. C.	Ø 4.001 - 4.006 (101.62 - 101.75)
SAE C, C5: (4) - ¹ / ₂ " -13 UNC 2B Thd Holes on 6.375 (161.93) B. C.	Ø 5.001 - 5.006 (127.02 - 127.15)

+ "O" RING OR GASKET REQUIRED (Not Supplied by Auburn Gear)
"O" RING SIZES: SAE "B" 2-155 (614120), SAE "C" 2-159 (614136)

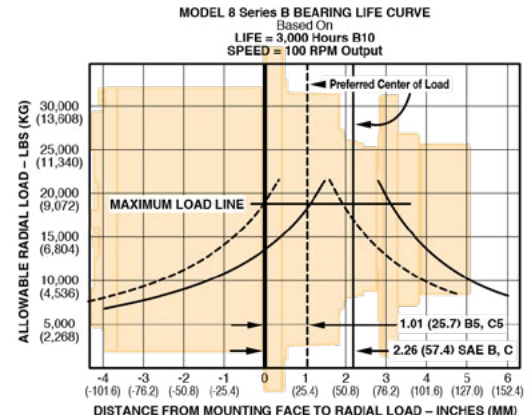

NOTE:

These curves are supplied as a design guide and apply to resultant radial load only. They indicate the importance of maintaining wheel position over the bearing center. For actual analysis, applications should be reviewed by Auburn Gear Engineering using data supplied on Application Data Form.

Bearing Load, Life, and Speed Relationships

$$LF = \frac{SF \times R}{R'}$$

R = Allowable resultant load or given location from mounting flange
R' = Anticipated load at location from mounting flange
LF = Life Factor from table (see Below)
SF = Speed Factor from Table (see Below)

OUTPUT SPEED (RPM)	SF	LF	BEARING HOURS B-10 LIFE
5	2.456	0.584	500
10	1.994	0.719	1000
20	1.620	0.812	1500
30	1.435	0.886	2000
40	1.316	0.947	2500
50	1.231	1.000	3000
60	1.165	1.047	3500
70	1.113	1.090	4000
80	1.069	1.130	4500
90	1.032	1.166	5000
100	1.000	1.231	6000
200	0.812	1.289	7000
300	0.719	1.342	8000
400	0.659	1.390	9000
500	0.617	1.435	10000

CAUTION: The same torsional loading constraints used in the driving mode must be used in the braking mode when braking through the Power Wheel drive gear set.

NOTE:

The data presented in this catalog is for general information and preliminary layout purposes only. Auburn Gear, through its policy of continual improvement, reserves the right to update its products; therefore, the information presented is subject to change. For specific application and/or dimensional information, contact Auburn Gear.

GENERAL SPECIFICATIONS

Max. intermittent output torque^{1,2}.....100,000 lb-in (11,300 Nm)
Max. input speed².....5,000 RPM

Approximate Weight.....222 lbs (100.7 kg)
Oil Capacity.....55 oz (1,625 ml)

For Lubrication Data, See Page 18

¹ Depending on the duty cycle and the nature of the application, a normal continuous output torque of 1/3 to 1/2 of the maximum intermittent should yield satisfactory Power Wheel life. Customer testing and application analysis is strongly recommended.

² If application exceeds published limits, contact Auburn Gear.

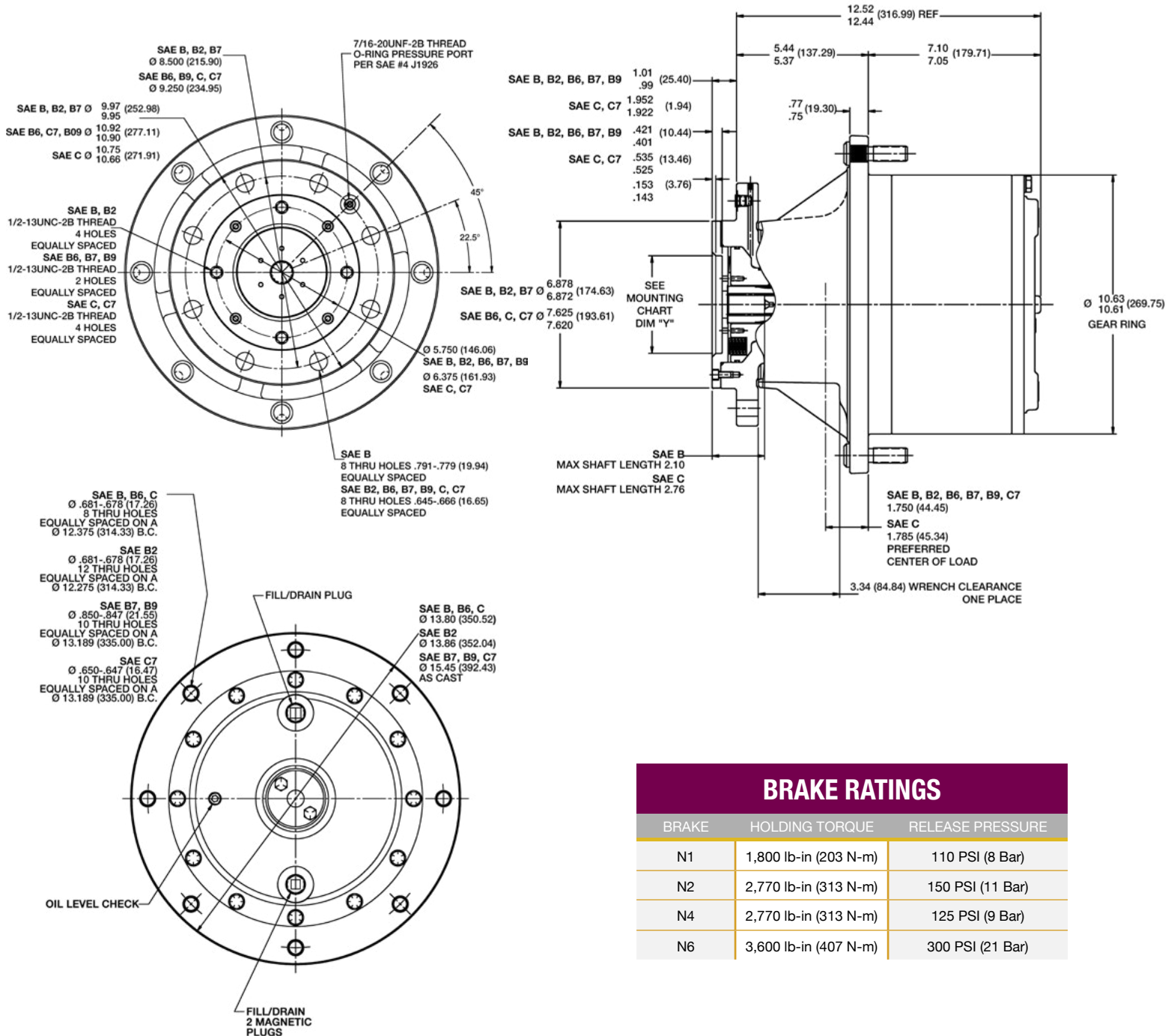

BRAKE RATINGS

BRAKE	HOLDING TORQUE	RELEASE PRESSURE
N1	1,800 lb-in (203 N-m)	110 PSI (8 Bar)
N2	2,770 lb-in (313 N-m)	150 PSI (11 Bar)
N4	2,770 lb-in (313 N-m)	125 PSI (9 Bar)
N6	3,600 lb-in (407 N-m)	300 PSI (21 Bar)

Model 8 Series B Wheel Drives with N-Series Fully Integrated Brake

Model 8 Series B Wheel Drives • Double Reduction with N-Series Fully Integrated Brake

FEATURE CHART: Model 8 Series B Shaft Output Drives Double Reduction With N-Series Fully Integrated Brake					
OPTIONS	DESCRIPTION	MAKE ALL SELECTIONS WITHIN ONE COLUMN		ORDER CODES	USE OPTION ORDER CODES TO BUILD ORDER NUMBER
MOTOR PILOT/HUB	SAE B	•		8W2B	8W2B7
	B2	•		8W2B2	
	B6	•		8W2B6	
	B7	•		8W2B7	
	B9	•		8W2B9	
	SAE C	•	•	8W2C	
	C7	•	•	8W2C7	
INPUT SPLINE	13T - 16/32	•		13	15
	14T - 12/24	•	•	14	
	15T - 16/32	•		15	
RATIO OPTIONS	14.39:1	•	•	14	34
	17.83:1	•	•	17	
	22.59:1	•	•	22	
	25.71:1	•	•	25	
	30.50:1	•	•	30	
	34.20:1	•	•	34	
	37.89:1	•	•	37	
	41.42:1	•	•	41	
49.00:1	•	•	49		
WHEEL STUDS	NONE	•	•	0	18
	5/8" x 2.37	•	•	8	
	3/4" x 2.76*	•	•	9	
	3/4" x 3.21*	•	•	11	
	1/2" x 2.50	•	•	16	
	9/16" x 2.75	•	•	18	
	M20-1.5-6g	•	•	19	
PARKING BRAKE	1,800 lb-in	•	•	N1	N4
	2,770 lb-in	•	•	N2	
	2,770 lb-in	•	•	N4	
	3,600 lb-in	•	•	N6	
SPECIAL FEATURES	Oil Plugs/Spindle Side	•	•	P	P
	High-Strength Secondary Carrier	•	•	Y	
	Boot Seal	•	•	Z	
	H.D. Multi-Lip Seal	•	•	T	T
	Quick Disconnect	•	•	Q	

Bearing Chart currently unavailable. Contact Auburn Gear for more information.

NOTE:
These curves are supplied as a design guide and apply to resultant radial load only. They indicate the importance of maintaining wheel position over the bearing center. For actual analysis, applications should be reviewed by Auburn Gear Engineering using data supplied on Application Data Form.

Bearing Load, Life, and Speed Relationships

$$LF = \frac{SF \times R}{R'}$$

R = Allowable resultant load at given location from mounting flange
R' = Anticipated load at location from mounting flange
LF = Life Factor from table (see Below)
SF = Speed Factor from Table (see Below)

OUTPUT SPEED (RPM)	SF	LF	BEARING HOURS B-10 LIFE
5	2.456	0.584	500
10	1.994	0.719	1000
20	1.620	0.812	1500
30	1.435	0.886	2000
40	1.316	0.947	2500
50	1.231	1.000	3000
60	1.165	1.047	3500
70	1.113	1.090	4000
80	1.069	1.130	4500
90	1.032	1.166	5000
100	1.000	1.231	6000
200	0.812	1.289	7000
300	0.719	1.342	8000
400	0.659	1.390	9000
500	0.617	1.435	10000

CAUTION: The same torsional loading constraints used in the driving mode must be used in the braking mode when braking through the Power Wheel drive gear set.

NOTE:
The data presented in this catalog is for general information and preliminary layout purposes only. Auburn Gear, through its policy of continual improvement, reserves the right to update its products; therefore, the information presented is subject to change. For specific application and/or dimensional information, contact Auburn Gear.

Select desired characteristics from chart, note correct order codes, and order using sample format shown at right: **8W2B7 15 34 18 N4 PT**

* Not available with B, B2, B6 or C mounting.

MOTOR MOUNTING CHART

MOTOR MOUNTING HOLE DIMENSIONS	DIAMETER
SAE B, B2: (4) - 1/2" -13 UNC 2B Thd Holes on 5.750 (146.0) 5B. C.	Ø 4.001 - 4.006 (101.62 - 101.75)
SAE B6, B7, B9: (2) - 1/2" -13 UNC 2B Thd Holes on 5.750 (146.05) B. C.	Ø 4.001 - 4.006 (101.62 - 101.75)
SAE C, C7: (4) - 1/2" -13 UNC 2B Thd Holes on 6.375 B. C.	Ø 5.001 - 5.006 (127.02 - 127.15)

* "O" RING OR GASKET REQUIRED (Not Supplied by Auburn Gear)
"O" RING SIZES: SAE "B" 2-155 (614120), SAE "C" 2-159 (614136)

GENERAL SPECIFICATIONS

Single Reduction Drives

Max. intermittent output torque^{1,2}.....60,000 lb-in (6,780 Nm)
 Max. input speed².....3,500 RPM

Approximate Weight.....158 lbs (72 kg)
 Oil Capacity.....48 oz (1,420 cc)

Double Reduction Drives

Max. intermittent output torque^{1,2}.....100,000 lb-in (11,300 Nm)
 Max. input speed².....5,000 RPM

Approximate Weight.....194 lbs (88 kg)
 Oil Capacity.....52 oz (1,540 cc)

For Lubrication Data, See Page 18

¹ Depending on the duty cycle and the nature of the application, a normal continuous output torque of 1/3 to 1/2 of the maximum intermittent should yield satisfactory Power Wheel life. Customer testing and application analysis is strongly recommended.

² If application exceeds published limits, contact Auburn Gear.

SAE A, B, C, D

Dimensions given in: INCHES (mm)

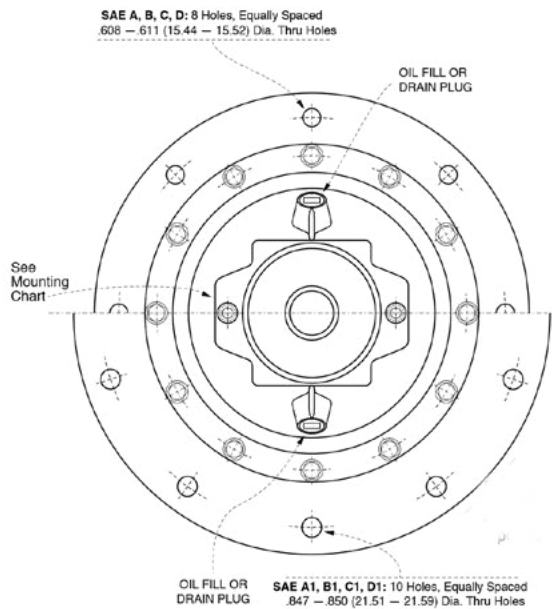

SINGLE REDUCTION
 SAE A, A1: 10.44 (265.2) + Dim. "A"
 SAE B, B1: 10.35 (262.9) + Dim. "A"
 SAE C, C1: 11.10 (281.9) + Dim. "A"
 SAE D, D1: 11.85 (301.0) + Dim. "A"

DOUBLE REDUCTION
 SAE A, A1: 12.42 (315.5) + Dim. "A"
 SAE B, B1: 11.10 (281.9) + Dim. "A"
 SAE C, C1: 12.33 (313.2) + Dim. "A"
 SAE D, D1: 13.08 (332.3) + Dim. "A"

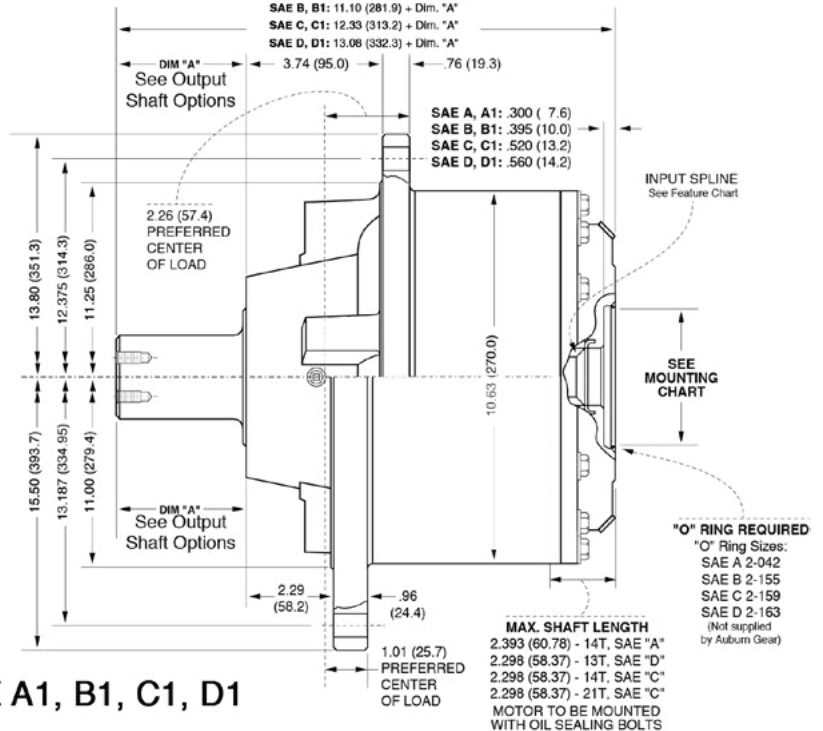

SAE A1, B1, C1, D1

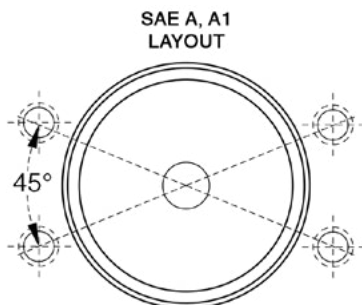

MOTOR MOUNTING CHART

MOTOR MOUNTING HOLE DIMENSIONS	DIAMETER
SAE A, A1: (4) - 1/2" -13 UNC 2B Thd Holes on 4.188 (106.38) B. C.	Ø 3.251 - 3.256 (82.58 - 82.70)
SAE B, B1: (2) - 1/2" -13 UNC 2B Thd Holes on 5.750 (146.05) B. C.	Ø 4.001 - 4.006 (101.62 - 101.75)
SAE C, C1: (4) - 1/2" -13 UNC 2B Thd Holes on 6.375 (161.93) B. C. OR (2) - 5/8" -11 UNC 2B Thd Holes on 7.125 (180.98) B. C.	Ø 5.001 - 5.006 (127.02 - 127.15)
SAE D, D1: (4) - 3/4" -10 UNC 2B Thd Holes on 9.000 (228.60) B. C.	Ø 6.001 - 6.006 (152.43 - 152.55)

*"O" RING OR GASKET REQUIRED (Not Supplied by Auburn Gear)
 "O" RING SIZES: SAE "A" 2-042 (614163), SAE "B" 2-155 (614120), SAE "C" 2-159 (614136), SAE "D" 2-163

Model 8 Series B Shaft & Flanged Output Drives • Single & Double Reductions

FEATURE CHART: Model 8 Series B Shaft & Flanged Output Drives - Single Reduction

OPTIONS	DESCRIPTION	MAKE ALL SELECTIONS WITHIN ONE COLUMN				ORDER CODES	USE OPTION ORDER CODES TO BUILD ORDER NUMBER		
MOTOR PILOT/HUB	SAE A					8T2A	8T2C		
	A1					8T2A1			
	SAE B					8T2B			
	B1					8T2B1			
	SAE C					8T2C			
	C1					8T2C1			
SAE D					8T2D				
D1					8T2D1				
INPUT SPLINE	13T - 8/16					13	14		
	14T - 12/24					14			
	17T - 12/24					17			
RATIO OPTIONS	3.92:1					03			07
	4.86:1					04			
	5.50:1					05			
	6.00:1					06			
	7.07:1					07			
OUTPUT SHAFTS	2.5" Hex					H1			K2
	2.0" Hex					H3			
	3.0" Keyed					K2			
	20T - 8/16					20			
	23T - 8/16					23S			
	23T - 8/16					23L			
	(8) 5/8" - 11 on 9.50" BC					F1			
	(8) Thru Holes on 9.50" BC					F2			
	(8) 3/4" - 10 on 9.50" BC					F5			
	(8) 5/8" - 11 on 6.00" BC					F6			

Select desired characteristics from chart, note correct order codes, and order using sample format shown at right:

8T2C 14 07 K2

FEATURE CHART: Model 8 Series B Shaft & Flanged Output Drives - Double Reduction

OPTIONS	DESCRIPTION	MAKE ALL SELECTIONS WITHIN ONE COLUMN				ORDER CODES	USE OPTION ORDER CODES TO BUILD ORDER NUMBER		
MOTOR PILOT/HUB	SAE A					8S2A	8S2B		
	A1					8S2A1			
	SAE B					8S2B			
	B1					8S2B1			
	SAE C					8S2C			
	C1					8S2C1			
SAE D					8S2D				
D1					8S2D1				
INPUT SPLINE	13T - 16/32					13	13		
	13T - 8/16					13			
	14T - 12/24					14			
RATIO OPTIONS	15.29:1					15			31
	18.83:1					18			
	23.59:1					23			
	26.71:1					26			
	31.50:1					31			
	35.20:1					35			
	42.42:1					42			
	50.00:1					50			
	OUTPUT SHAFTS	2.5" Hex							
2.0" Hex						H3			
3.0" Keyed						K2			
20T - 8/16						20			
23T - 8/16						23S			
23T - 8/16						23L			
(8) 5/8" - 11 on 9.50" BC						F1			
(8) Thru Holes on 9.50" BC						F2			
(8) 3/4" - 10 on 9.50" BC						F5			
(8) 5/8" - 11 on 6.00" BC						F6			

Select desired characteristics from chart, note correct order codes, and order using sample format shown at right:

8S2B 13 31 K2

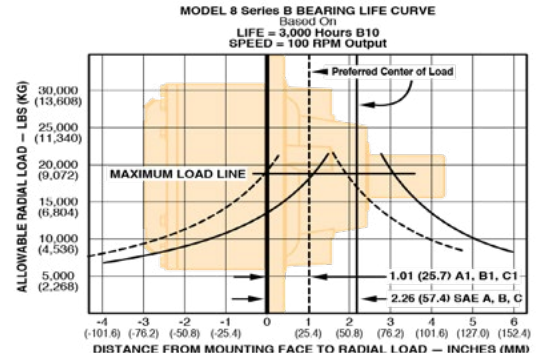

NOTE:

These curves are supplied as a design guide and apply to resultant radial load only. They indicate the importance of maintaining wheel position over the bearing center. For actual analysis, applications should be reviewed by Auburn Gear Engineering using data supplied on Application Data Form.

Bearing Load, Life, and Speed Relationships

$$LF = \frac{SF \times R}{R'}$$

R = Allowable resultant load or given location from mounting flange
 R' = Anticipated load at location from mounting flange
 LF = Life Factor from table (see Below)
 SF = Speed Factor from Table (see Below)

OUTPUT SPEED (RPM)	SF	LF	BEARING HOURS B-10 LIFE
5	2.456	0.584	500
10	1.994	0.719	1000
20	1.620	0.812	1500
30	1.435	0.886	2000
40	1.316	0.947	2500
50	1.231	1.000	3000
60	1.165	1.047	3500
70	1.113	1.090	4000
80	1.069	1.130	4500
90	1.032	1.166	5000
100	1.000	1.231	6000
200	0.812	1.289	7000
300	0.719	1.342	8000
400	0.659	1.390	9000
500	0.617	1.435	10000

CAUTION: The same torsional loading constraints used in the driving mode must be used in the braking mode when braking through the Power Wheel drive gear set.

NOTE:

The data presented in this catalog is for general information and preliminary layout purposes only. Auburn Gear, through its policy of continual improvement, reserves the right to update its products; therefore, the information presented is subject to change. For specific application and/or dimensional information, contact Auburn Gear.

Power Wheel®

Model 8 Series B Shaft & Flanged Output Drives • Double Reduction with A2 Series Integral Parking Brake¹

GENERAL SPECIFICATIONS

Max. intermittent output torque^{2,3}.....100,000 lb-in (11,300 Nm)
 Max. input speed⁴.....4,000 RPM

Approximate Weight.....194 lbs (88 kg)
 Oil Capacity.....50 oz (1,478 cc)

For Lubrication Data, See Page 18

¹For vertical applications, shaft up or down, contact Auburn Gear.

²Depending on the duty cycle and the nature of the application, a normal continuous output torque of 1/3 to 1/2 of the maximum intermittent should yield satisfactory Power Wheel life. Customer testing and application analysis is strongly recommended.

³If application exceeds published limits, contact Auburn Gear.

⁴For input speeds above 4,000 RPM please contact Auburn Gear for duty cycle analysis.

SAE B, C

Dimensions given in: INCHES (mm)

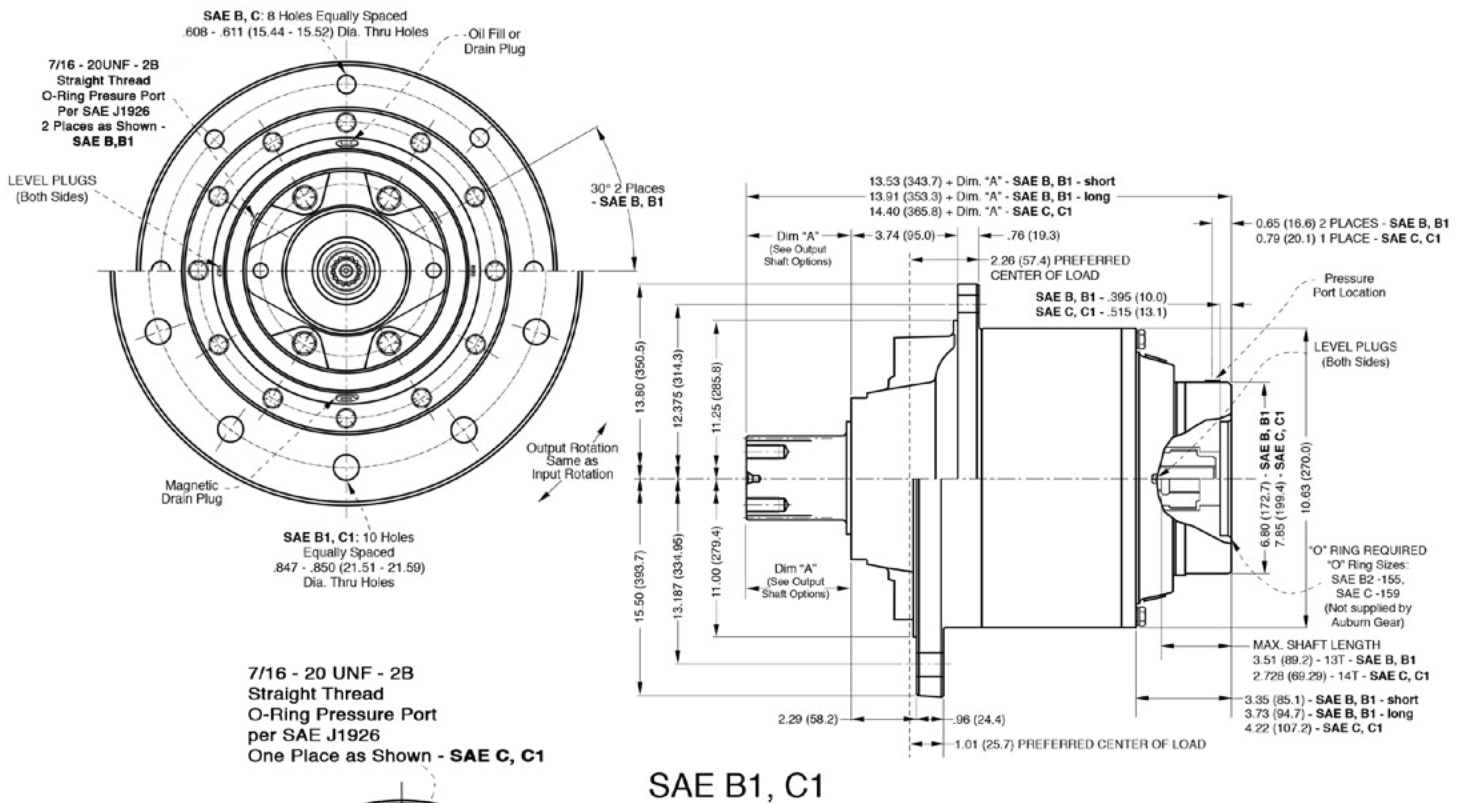

Model 8 Series B Shaft & Flanged Output Drives • Double Reduction with A2 Series Integral Parking Brake

FEATURE CHART: Model 8 Series B Shaft & Flanged Output Drives - Double Reduction With Brake

OPTIONS	DESCRIPTION	MAKE ALL SELECTIONS WITHIN ONE COLUMN		ORDER CODES	USE OPTION ORDER CODES TO BUILD ORDER NUMBER	
MOTOR PILOT/HUB	SAE B B1 SAE C C1	•	•	8S2B 8S2B1 8S2C 8S2C1	8S2B	
INPUT SPLINE	13T - 16/32 14T - 12/24	•	•	13 14	13	
RATIO OPTIONS	15.39:1 18.83:1 23.59:1 26.71:1 31.50:1 35.20:1 42.42:1 50.00:1	•	•	15 18 23 26 31 35 42 50		42
OUTPUT SHAFTS	3.0" Keyed 2.5" Hex 20T - 8/16 23T - 8/16 23T - 8/16 (8) 5/8" - 11 on 9.50 BC (8) Thru on 9.50 BC (8) 3/4" - 10 on 9.50 BC (8) 5/8" - 11 on 6.50 BC	•	•	K2 H1 20 23S 23L F1 F2 F5 F6		20
PARKING BRAKE	SHORT VERSION 1,800 lb-in 2,400 lb-in LONG VERSION 2,400 lb-in 3,200 lb-in 3,600 lb-in 4,200 lb-in	•	•	B2 B3 B4 B5 B6 B7		B6

Select desired characteristics from chart, note correct order codes, and order using sample format shown at right:

8S2B 13 42 20 B6

MOTOR MOUNTING CHART

MOTOR MOUNTING HOLE DIMENSIONS	DIAMETER
SAE B, B1: (2) - 1/2" -13 UNC 2B Thd Holes on 5.750 (146.0) 5B	Ø 4.001 - 4.006 (101.62 - 101.75)
SAE C, C1: (4) - 1/2" -13 UNC 2B Thd Holes on 6.375 (161.93) B. C.	Ø 5.001 - 5.006 (127.02 - 127.15)

*"O" RING OR GASKET REQUIRED (Not Supplied by Auburn Gear)
"O" RING SIZES: SAE "B" 2-155 (614120), SAE "C" 2-159 (614136)

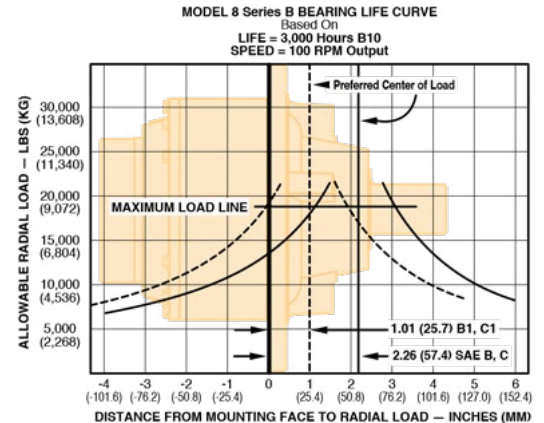

NOTE:

These curves are supplied as a design guide and apply to resultant radial load only. They indicate the importance of maintaining wheel position over the bearing center. For actual analysis, applications should be reviewed by Auburn Gear Engineering using data supplied on Application Data Form.

Bearing Load, Life, and Speed Relationships

$$LF = \frac{SF \times R}{R'}$$

R = Allowable resultant load or given location from mounting flange
R' = Anticipated load at location from mounting flange
LF = Life Factor from table (see Below)
SF = Speed Factor from Table (see Below)

OUTPUT SPEED (RPM)	SF	LF	BEARING HOURS B-10 LIFE
5	2.456	0.584	500
10	1.994	0.719	1000
20	1.620	0.812	1500
30	1.435	0.886	2000
40	1.316	0.947	2500
50	1.231	1.000	3000
60	1.165	1.047	3500
70	1.113	1.090	4000
80	1.069	1.130	4500
90	1.032	1.166	5000
100	1.000	1.231	6000
200	0.812	1.289	7000
300	0.719	1.342	8000
400	0.659	1.390	9000
500	0.617	1.435	10000

CAUTION: The same torsional loading constraints used in the driving mode must be used in the braking mode when braking through the Power Wheel drive gear set.

NOTE:

The data presented in this catalog is for general information and preliminary layout purposes only. Auburn Gear, through its policy of continual improvement, reserves the right to update its products; therefore, the information presented is subject to change. For specific application and/or dimensional information, contact Auburn Gear.

Model 8 Series B Shaft Input/Shaft & Flanged Output Drives

Model 8 Series B Shaft Input/Shaft & Flanged Output Drives

• Double Reduction

FEATURE CHART: Model 8 Series B Shaft Input/Shaft & Flanged Output Drives - Single Reduction

OPTIONS	DESCRIPTION	MAKE ALL SELECTIONS WITHIN ONE COLUMN	ORDER CODES	USE OPTION ORDER CODES TO BUILD ORDER NUMBER		
HUB	Small Flange	•	8T2	8T2		
	Large Flange	•	8T21			
INPUT SHAFT OPTIONS	1 1/2" Keyed	•	K00		K00	
RATIO OPTIONS	3.92:1	•	03			03
OUTPUT SHAFTS	3.0" Keyed	•	K2			20
	20T - 9/16	•	20			
	23T - 9/16	•	23S			
	23T - 9/16	•	23L			
	(8) 5/8" - 11 on 9.50 BC	•	F1			
	(8) Thru on 9.50 BC	•	F2			
(8) 3/4" - 10 on 9.50 BC	•	F5				
(8) 5/8" - 11 on 6.00 BC	•	F6				

Select desired characteristics from chart, note correct order codes, and order using sample format shown at right:

8S2 K00 23 20

FEATURE CHART: Model 8 Series B Shaft Input/Shaft & Flanged Output Drives - Double Reduction

OPTIONS	DESCRIPTION	MAKE ALL SELECTIONS WITHIN ONE COLUMN	ORDER CODES	USE OPTION ORDER CODES TO BUILD ORDER NUMBER		
HUB	Small Flange	•	8S2	8S2		
	Large Flange	•	8S21			
INPUT SHAFT OPTIONS	1 1/2" Keyed	•	K00		K00	
RATIO OPTIONS	15.39:1	•	15			23
	18.83:1	•	18			
	23.59:1	•	23			
	26.71:1	•	26			
	31.50:1	•	31			
	35.20:1	•	35			
	42.42:1	•	42			
	50.00:1	•	50			
	3.0" Keyed	•	K2			
20T - 9/16	•	20				
23T - 9/16	•	23S				
23T - 9/16	•	23L				
(8) 5/8" - 11 on 9.50 BC	•	F1				
(8) Thru on 9.50 BC	•	F2				
(8) 3/4" - 10 on 9.50 BC	•	F5				
(8) 5/8" - 11 on 6.00 BC	•	F6				

Select desired characteristics from chart, note correct order codes, and order using sample format shown at right:

8S2 K00 23 20

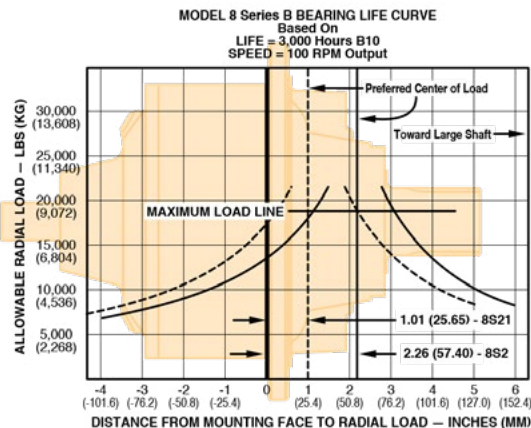

NOTE:

These curves are supplied as a design guide and apply to resultant radial load only. They indicate the importance of maintaining wheel position over the bearing center. For actual analysis, applications should be reviewed by Auburn Gear Engineering using data supplied on Application Data Form.

Bearing Load, Life, and Speed Relationships

$$LF = \frac{SF \times R}{R'}$$

R = Allowable resultant load or given location from mounting flange
 R' = Anticipated load at location from mounting flange
 LF = Life Factor from table (see Below)
 SF = Speed Factor from Table (see Below)

OUTPUT SPEED (RPM)	SF	LF	BEARING HOURS B-10 LIFE
5	2.456	0.584	500
10	1.994	0.719	1000
20	1.620	0.812	1500
30	1.435	0.886	2000
40	1.316	0.947	2500
50	1.231	1.000	3000
60	1.165	1.047	3500
70	1.113	1.090	4000
80	1.069	1.130	4500
90	1.032	1.166	5000
100	1.000	1.231	6000
200	0.812	1.289	7000
300	0.719	1.342	8000
400	0.659	1.390	9000
500	0.617	1.435	10000

CAUTION: The same torsional loading constraints used in the driving mode must be used in the braking mode when braking through the Power Wheel drive gear set.

NOTE:

The data presented in this catalog is for general information and preliminary layout purposes only. Auburn Gear, through its policy of continual improvement, reserves the right to update its products; therefore, the information presented is subject to change. For specific application and/or dimensional information, contact Auburn Gear.

Model 8 Series B Shaft and Spindle Output Options

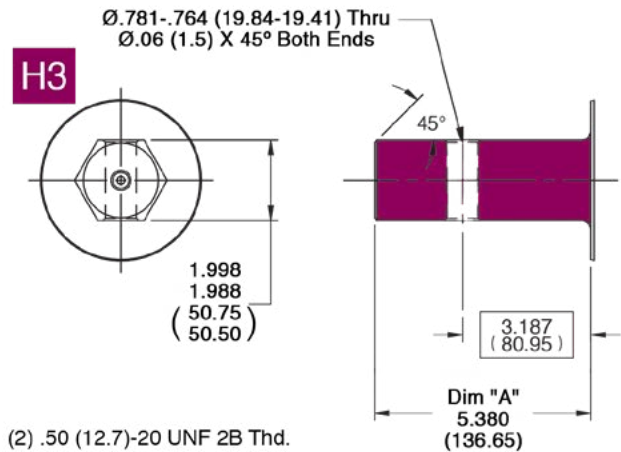
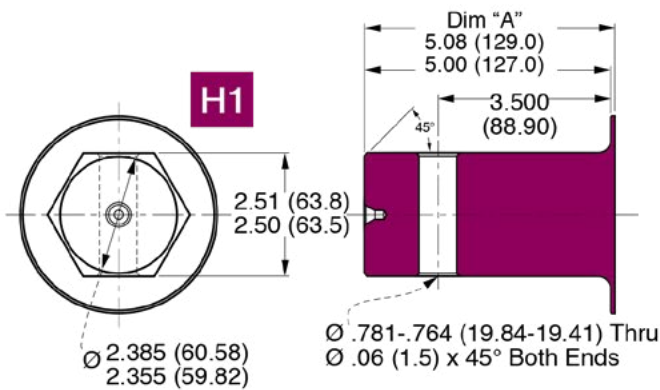
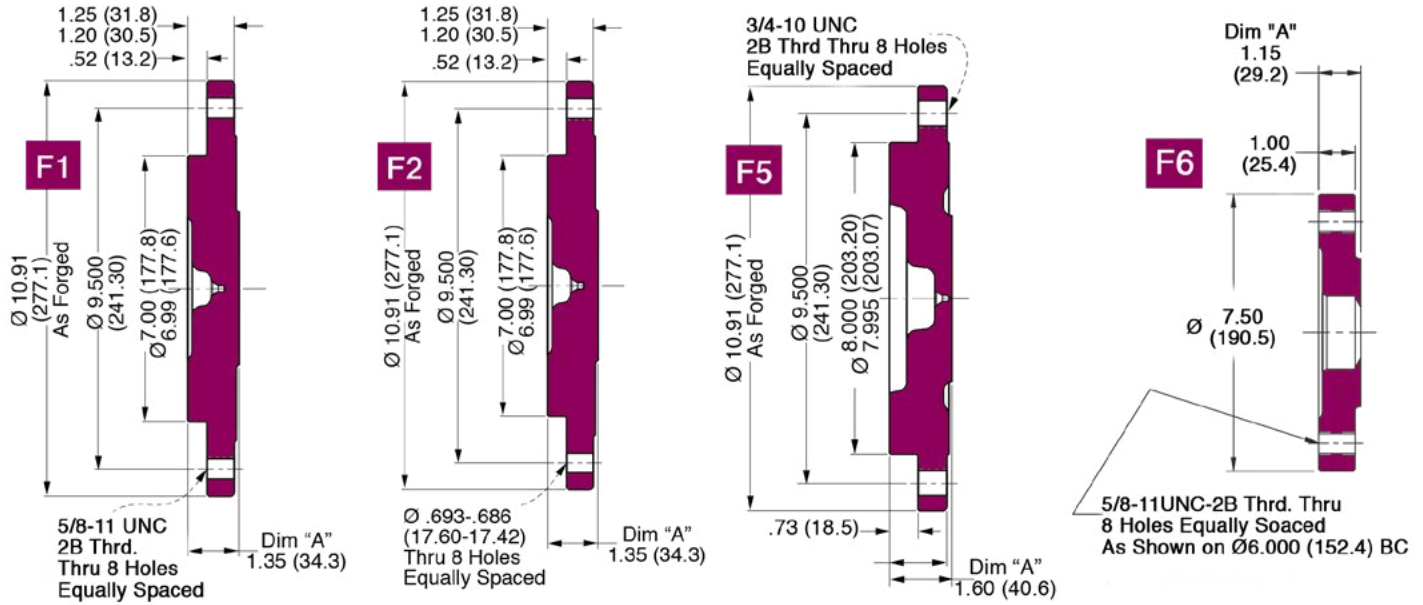

(2) .50 (12.7)-20 UNF 2B Thd. 1.00 (25.4) Min. Deep

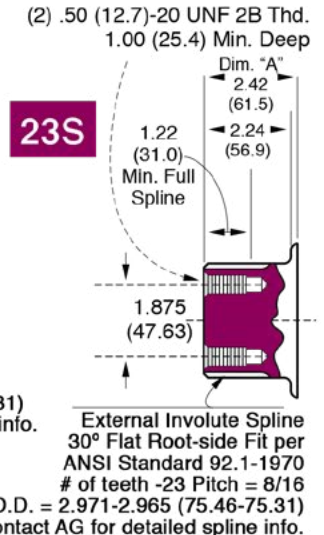
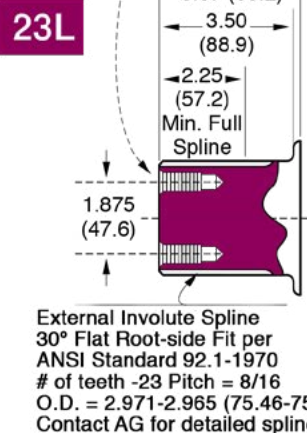
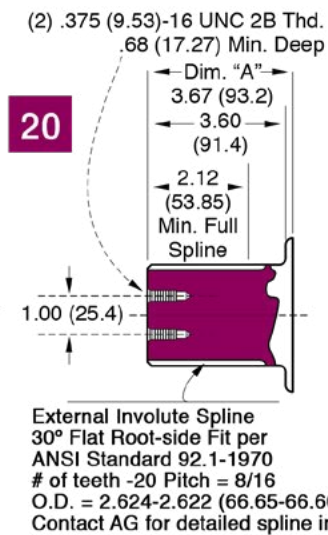
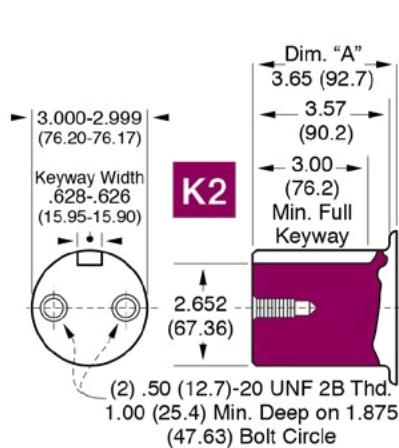

Model 8 Series B Other Options

Weldable Hub

The hubs are 4140H steel and can be turned down and/or welded for mounting sprockets, pulleys, or other devices. A circular keeper plate secures the hub to the splined output shaft with two bolts (keeper plate and bolts included).

KIT NUMBER	SPLINE	FITS MODELS
6420105	23T - $1\frac{1}{2}/24$	5, 6, & 8
6420106	23T - $\frac{8}{16}$	6B, 7, 8B, 9, & 10
6420107	20T - $\frac{8}{16}$	8, 8B, & 9
*618005	20T - $\frac{6}{12}$	10, 200, 250, & 350

*Keeper plate & bolts not included.

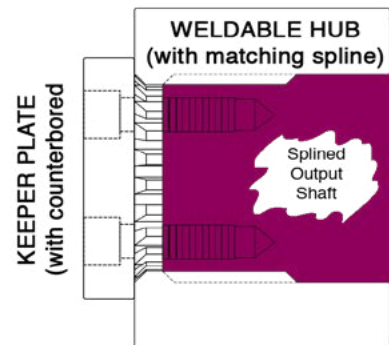

Boot Seal

An optional seal that protects the main oil seal from dirt and other debris. The boot seal will give extended life on applications operating in extremely muddy or dirty conditions. Boot seals are available on a selective model basis.

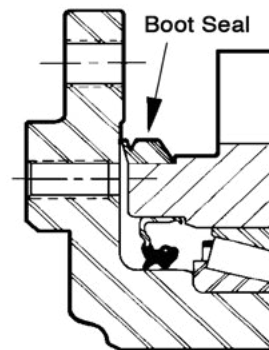

Guard and Boot Seal System

A boot seal and metal guard are available with F5 spindle output units only. These can be ordered separately or together. They function best together. The guard and boot seal system are utilized in extremely high grit applications. The guard protects the boot seal from contaminants which will ultimately wear the boot seal lip.

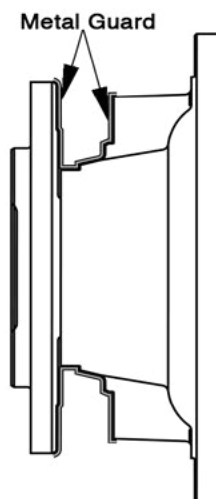

1800-OILSOL
1800-645765

<https://oilsolutions.com.au/>

sales@oilsolutions.com.au

Quick Disconnect

This optional disconnect is available on all wheel drives. No tools are needed to disengage or re-engage the drive. The planetary drive is disengaged with the push of a button. The quick disconnect eliminates removal of the disconnect cover and external contaminants are sealed from the units by internal o-rings and a gasket that is sandwiched between the disconnect and planetary cover. The rugged, compact design ensures dependable service.

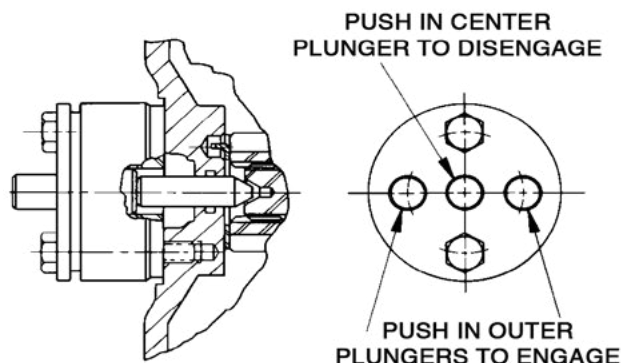

1. Type

In normal applications use an extreme pressure lubricant API-GL-5 approved. Auburn Gear recommends SAE 80W-90 grades of lube under normal climate and operating conditions. See chart below. For severe or abnormal applications with special requirements, consult either Auburn Gear or a lubricant manufacturer for further assistance.

2. Change Interval

Initial lubrications change after 50 hours of operation. Subsequent changes every 1,000 hours or yearly, whichever comes first.

3. Lube Temperature

Continuous operating temperatures of 160°F are allowable. Maximum intermittent temperature recommended is 200°F.

4. Amount of Lube

The unit should be half full when mounted horizontal. Lube levels for other mounts will vary. Consult Auburn Gear for details.

5. Shaft or Spindle Up Mounting

If mounting unit vertically with shaft or spindle up, special provisions apply to ensure adequate lubrication of output bearings. Consult Auburn Gear.

Power Wheel Planetary Drives are shipped without lubricant and must be filled to the proper level prior to start-up.

**AUBURN GEAR POWER WHEEL
LOW TEMPERATURE GEAR LUBE REQUIREMENT**

SAE Viscosity Grade	Auburn Gear Recommended Minimum Temperature
75W-90	-40°F (-40°C)*
80W, 80W-90	-15°F (-26°C)*
85W, 85W-90	10°F (-12°C)*
90	35°F (2°C)

* Maximum temperature for Brookfield Viscosity¹ of 150,000 centipoise (cP)² per SAE J306 MAR85

¹ Brookfield Viscosity—apparent viscosity as determined under ASTM D 2983

² 150,000 cP determined to provide sufficient low temperature lube properties for Auburn Gear Power Wheels



1800-OILSOL
1800-645765

<https://oilsolutions.com.au/>

sales@oilsolutions.com.au

Power Wheel Temperature Gear Lube Requirements

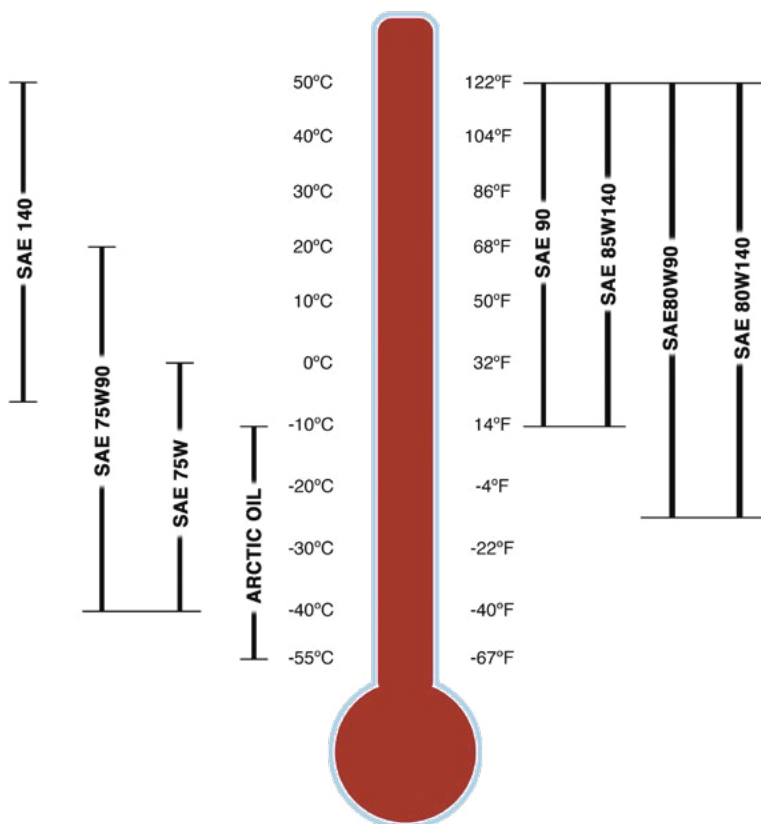

Power Wheel® Warranty

Seller warrants to Purchaser that its Power Wheel® planetary gear products are free from defects in material and workmanship under normal use and service for a period of one year from the date the product is shown to have been placed into operation by original user or for two years from date of shipment from seller's plant, whichever shall first occur.

Seller's obligation under this warranty is expressly limited to the repair or replacement at its option, of the Power Wheel which is returned with a written claim of defect f.o.b. seller's factory, Auburn, Indiana, U.S.A., and which is determined by Seller to be defective.

THIS IS THE SOLE AND ONLY WARRANTY OF SELLER AND NO OTHER WARRANTY IS APPLICABLE, EITHER EXPRESSED OR IMPLIED, IN FACT OR BY LAW, INCLUDING ANY WARRANTY AS TO MERCHANTABILITY OR FITNESS FOR A PARTICULAR USE OR PURPOSE.

The sole and only remedy in regard to any defective Power Wheel shall be the repair or replacement thereof herein provided, and seller shall not be liable for any consequential, special, incidental, or punitive damages, losses or expenses resulting from or cause by any defects.

Auburn Gear, LLC
Auburn, Indiana, U.S.A.





Providing Technology, Quality, & Customer Support Around the Globe



400 E. Auburn Drive • Auburn, IN 46706 USA
260.925.3200
www.AuburnGear.com



1800-OILSOL
1800-645765

<https://oilsolutions.com.au/>

sales@oilsolutions.com.au

*All specifications and data contained herein are nominal and subject to change without notice.
Specific applications should be referred to Auburn Gear for Current information.*