

# FRENI MODULARI / MODULAR BRAKES

I freni in dotazione ai riduttori epicicloidali Planetary Drives sono di tipo idraulico, con dischi a bagno d'olio, adatti esclusivamente alla freno statica, ovvero di parcheggio.

I freni hanno la lubrificazione separata da quella del riduttore epicicloidale. In fase di immissione del lubrificante bisognerà quindi provvedere anche al riempimento del freno, mediante un apposito foro adduzione olio posto sullo stesso.

Il lubrificante consigliato è un ISO VG 32. Normalmente possono andar bene gli oli idraulici.

Planetary Drives planetary reduction units are equipped with hydraulic brakes with oil-bath disks, expressly designed for static or parking braking.

The lubrication for the brakes is separated from the lubrication of the planetary gear units. Thus, during the lubricant inlet phase, it is necessary to pour the fluid also into the brake through the proper hole mounted on its casing.



We suggest to use lubricant ISO VG 32 (however, hydraulic lubricants can be used as well).





1800-OILSOL  
1800-645765

<https://oilsolutions.com.au/>

[sales@oilsolutions.com.au](mailto:sales@oilsolutions.com.au)

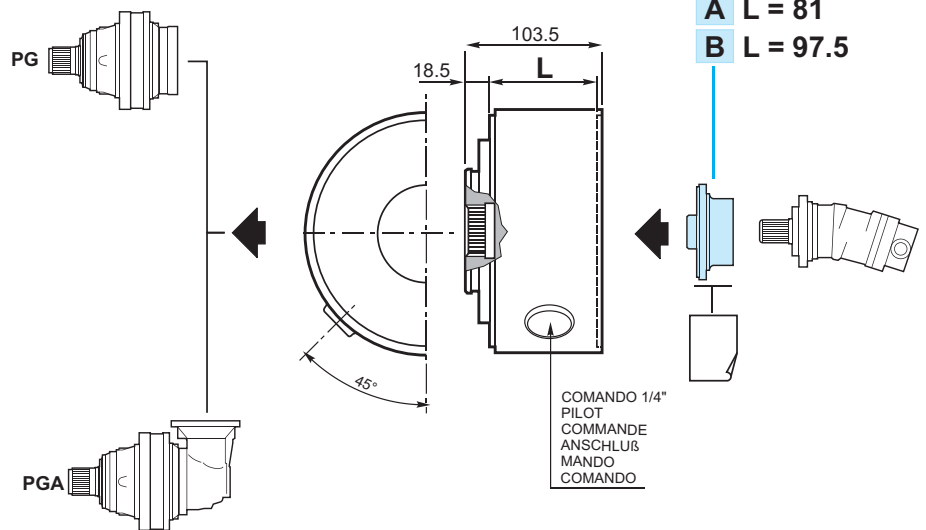
	RA		RA
PG 100	1-2-3-4	PGA 100	2-3-4
PG 160	1-2-3-4	PGA 160	2-3-4
PG 250	1-2-3-4	PGA 250	2-3-4
PG 500	1-2-3-4	PGA 500	2-3-4
PG 700	2-3-4	PGA 700	2-3-4
PG 1000	2-3-4	PGA 1000	2-3-4
PG 1600	2-3-4	PGA 1600	3-4
PG 1800	3-4	PGA 1800	3-4
PG 2500	3-4	PGA 2500	3-4
PG 3000	3-4	PGA 3000	3-4
PG 3500	3-4	PGA 3500	3-4
PG 5000	3-4	PGA 5000	3-4
PG 6500	4	PGA 6500	4
PG 9000	4	PGA 9000	4
PG 12000	4-5	PGA 12000	4-5
PG 16000	4-5	PGA 16000	5
PG 21000	4-5	PGA 21000	5
PG 21000 H	4-5	PGA 21000 H	5
PG 26000	5	PGA 26000	5
PG 31000	5	PGA 31000	5
PG 31000 H	5	PGA 31000 H	—
PG 40000	5	PGA 40000	—
PG 45000	5	PGA 45000	—
PG 53000	5	PGA 53000	—
PG 61000	—	PGA 61000	—



RA							
	Cfs <sub>min</sub> [Nm]	Pa <sub>min</sub> [bar]	Codice / Code Code / Bestell Nr.	P <sub>max</sub> [bar]	OIL [lt]		Kg
					V1	B5	
RA 10	90	17	4706.000.500	300	0.4	0.2	14
RA 16	140	23	4706.001.500				
RA 25	220	19	4706.002.500				
RA 35	330	23	4706.003.500				
RA 45	430	33	4706.004.500				
RA 55	550	39	4706.006.500				

N.B.: i numeri 1-2-3-4-5 indicano il numero di stadi dei riduttori.

N.B.: Les numéros 1-2-3-4-5 indiquent le nombre d'étages des réducteurs.

N.B.: Numbers 1-2-3-4-5 refer to the number of stages of the planetary gear unit.

Nota: los números 1-2-3-4-5 indican el número de etapas de los reductores.

N.B. Die Ziffern 1-2-3-4-5 geben die Anzahl der Getriebestufen an.

OBS.: os números 1-2-3-4-5 indicam o número de estágios do redutor.

# FRENI MODULARI / MODULAR BRAKES

	RB
PG 100	—
PG 160	—
PG 250	1
PG 500	1
PG 700	1-2
PG 1000	1-2
PG 1600	1-2
PG 1800	2-3
PG 2500	2-3
PG 3000	2-3
PG 3500	2-3
PG 5000	2-3
PG 6500	3-4
PG 9000	3-4
PG 12000	3-4
PG 16000	3-4
PG 21000	3-4
PG 21000 H	4-5
PG 26000	4-5
PG 31000	4-5
PG 31000 H	4-5
PG 40000	4-5
PG 45000	4-5
PG 53000	4-5
PG 61000	5

	RB
PGA 100	—
PGA 160	—
PGA 250	—
PGA 500	—
PGA 700	—
PGA 1000	—
PGA 1600	2
PGA 1800	—
PGA 2500	2
PGA 3000	—
PGA 3500	2-3
PGA 5000	2
PGA 6500	3
PGA 9000	3
PGA 12000	3
PGA 16000	3-4
PGA 21000	3-4
PGA 21000 H	3-4
PGA 26000	4
PGA 31000	4
PGA 31000 H	4-5
PGA 40000	4-5
PGA 45000	5
PGA 53000	5
PGA 61000	5

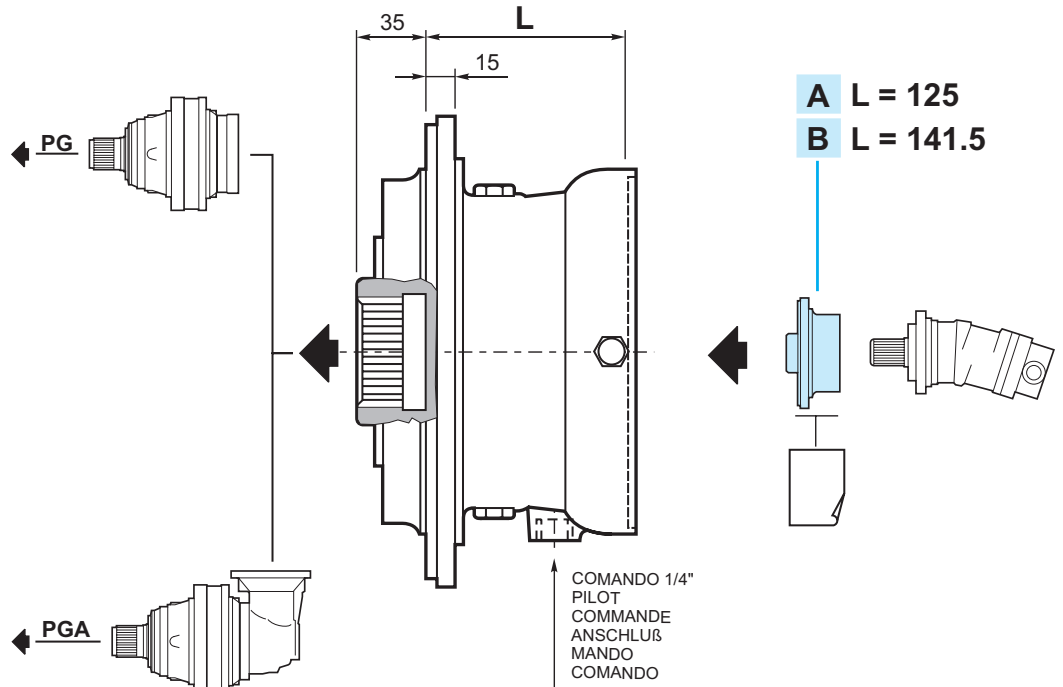

RB							
	Cfs <sub>min</sub> [Nm]	Pa <sub>min</sub> [bar]	Codice / Code Bestell Nr. / Code Código / Código	P <sub>max</sub> [bar]	OIL [lt]		Kg
					V1	B5	
RB 25	250	22	4705.300.500	300	0.6	0.3	21
RB 40	400	35	4705.301.500				
RB 63	650	50	4705.302.500				
RB 80	800	38	4705.303.500				
RB 100	1000	45	4705.304.500				
RB 125	1250	45	4705.305.500				
RB 160	1500	45	4705.306.500				
RB 180	1700	50	4705.307.500				

N.B.: i numeri 1-2-3-4-5 indicano il numero di stadi dei riduttori.

N.B.: Numbers 1-2-3-4-5 refer to the number of stages of the planetary gear unit.

N.B. Die Ziffern 1-2-3-4-5 geben die Anzahl der Getriebestufen an.

N.B.: Les numéros 1-2-3-4-5 indiquent le nombre d'étages des réducteurs.

Nota: los números 1-2-3-4-5 indican el número de etapas de los reductores.

OBS.: os números 1-2-3-4-5 indicam o número de estágios do redutor