

# Individual Winch Drive Systems from a Single Source





# Need Reliable Drive Systems for Your Winch? We Deliver Them.

Conditions on the high seas are harsh. It is therefore essential to use reliable quality and work with robust products. In addition, worldwide service is important – especially when it comes to the availability of spare parts and local service technicians.

In the shipbuilding sector winches are used to move heavy loads that weigh tonnes and are exposed to very large forces. These winches must be durable and able to interact easily with the individual components. Rexroth offers a product portfolio that is perfectly matched to these requirements; and the various components can be combined easily with each other.

A worldwide service network maximises availability and ensures swift help in the event that maintenance or repairs are needed.

---

**05 The Rexroth construction kit system:  
Everything from a single source**

---

**06 Which components make a winch drive system?**

08 Motors: Cores of the system

10 Gears: The addition to the axial piston unit

11 Brakes: Saving space through motor attachments

12 Winch control: One space-saving block, many functions

---

**13 Solutions for the closed circuit**

---

**14 Electronic controls**

---

**15 Rexroth Service:  
Your key to higher productivity**



# The Rexroth Construction Kit System: Everything from a Single Source

Rexroth offers a complete product range that conforms to modern winch systems and their requirements. Thanks to the modular construction kit system, we can find the optimum combination of individual components for every winch.

## Winch system construction kit

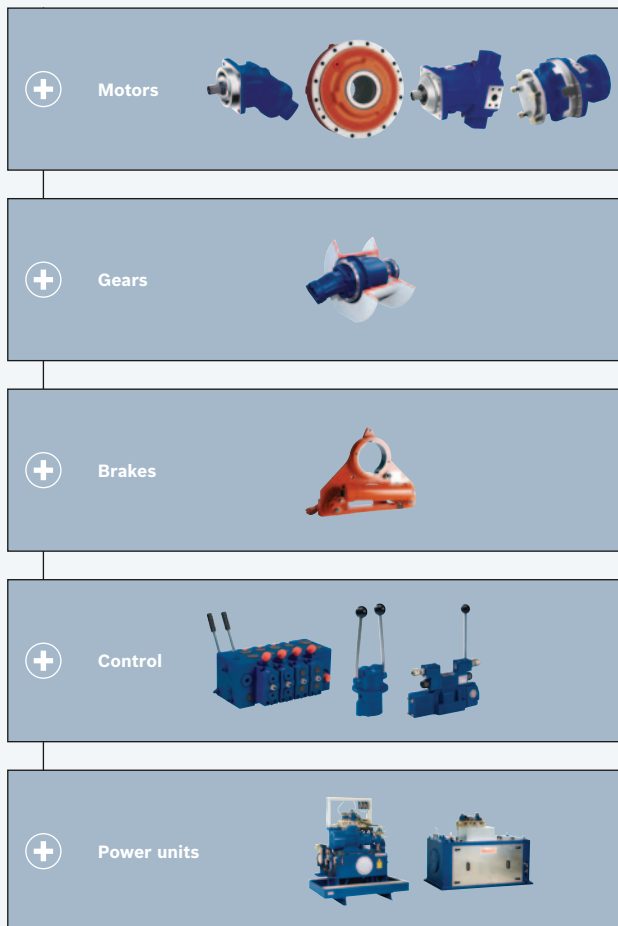

Rexroth offers a complete winch product range with proven components. Our longstanding experience and high standards offer you the safety that is required on the high seas. We will advise you from the first inquiry through to commissioning and beyond.

### Global thinking, local presence

Our services are available worldwide to help you minimise failures and downtimes. Regular maintenance will help you can increase the availability of your winch systems, thus reducing operating costs. We have offices in more than 80 countries and in nearly all important seaports. This virtually guarantees fast service.

# Which Components Make a Winch Drive System?

Rexroth offers various winch controls, which can be adapted to any winch with optional functions. This includes flow rates of up to 1000 l/min. We would be pleased to work out an individual solution with you on request.

## **Motors**

Due to the wide selection of motor types and their specific properties – high start-up efficiency, durability, ATEX certification, classifications and great power at low speed – Rexroth motors meet all the important requirements for winch applications. Just specify your requirement profile and we will find the right motor for you!

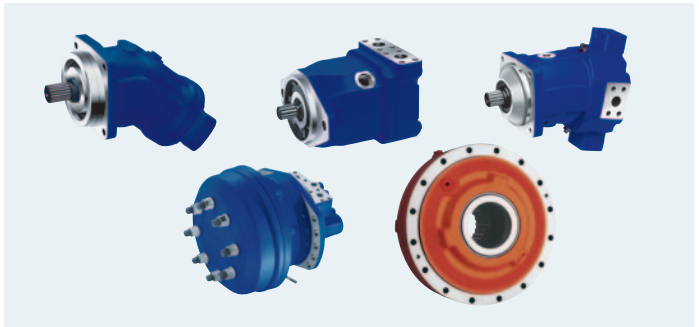

## **Gears**

The planetary gears MOBILEX GFT-W are suitable for the installation into winch drums of any kind of hoisting device. They are notably compact and equipped with an integrated multiple disk parking brake.

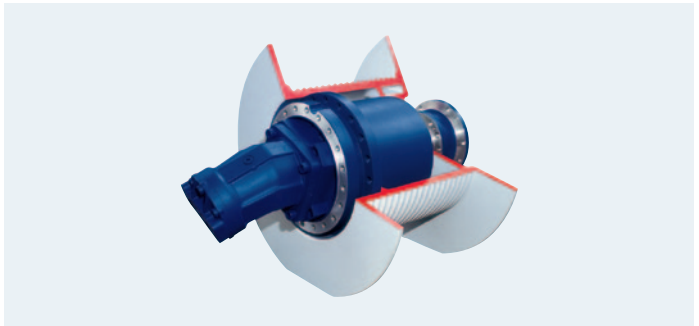

## **Brakes**

We offer different variants for seawater-proof brakes that are integrated into the hydraulic motor; these are also available with acceptance certificates from classification societies. With regard to our brakes, we pay the utmost attention to quality as well as robust and compact design and multifunctionality. Rexroth brakes are easy to mount; for some brakes, a remote control can even be selected as an option.





### Controls

Our valves meet exacting requirements in terms of function, performance and design, and are suitable for operation under harsh conditions. Our TH7 pilot control device has proven itself in many applications on deck for many years. It simplifies work through a progressive, sensitive and precise control without play. For simple winch controls, valves are offered in seawater-protected variants. Control blocks that are designed especially for ship winches can be mounted directly to the motor. Read more about our winch control blocks on the following pages.

### Power units

Rexroth offers matched 'power packs' to meet the requirements of any drive type in marine technology, and, like our components and systems, they are manufactured according to a uniform standard. This ensures low cost, long availability and high reliability. We deliver power units with certificates from all major classification societies. For yachts with special prerequisites, we can offer specific solutions that are tailored to the customer's needs, such as whispering power units or power units made of stainless steel.

# Motors: Cores of the System

Especially when it comes to motors, it is important that you get exactly the model that suits your requirements. With Rexroth, you can select from various alternatives.

## **Axial piston units**

Our axial piston units are the main components of a hydrostatic drive. They are available as pumps and motors, in both swashplate and bent-axis design, for the medium and high pressure range. Rexroth axial piston units offer great power density, high torque and optimum efficiency. High reliability paired with economic efficiency fulfils the most important criteria in favour of the use of hydrostatic drives. All motors are available with certificates from the most conventional classification societies.



◀ **A3FM:**  
Axial piston motor of bent-axis design with fixed swept volume

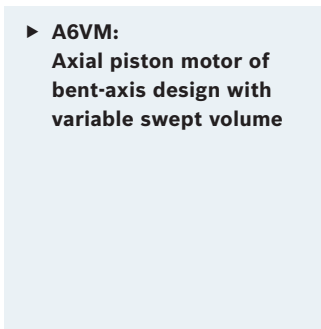

▶ **A6VM:**  
Axial piston motor of bent-axis design with variable swept volume



◀ **A10FM:**  
Axial piston motor of swashplate design with fixed swept volume



▶ **A10VSO:**  
Axial piston motor of swashplate design with variable swept volume

### Radial piston motors

Rexroth offers a wide selection of radial piston motors that are designed especially for heavy loads. They feature automatic overload protection and a high start-up efficiency with a low moment of inertia, which ensures fast response times.

The power density is five times higher than that of a conventional electric motor. The Viking motor was developed in particular for marine applications and winch drives. Torsion protection, free-wheeling function, low moment of inertia as well as low running noise are just a few of the benefits that make this motor so popular. Moreover, it can be mounted directly onto the winch drum, resulting in a very compact system.

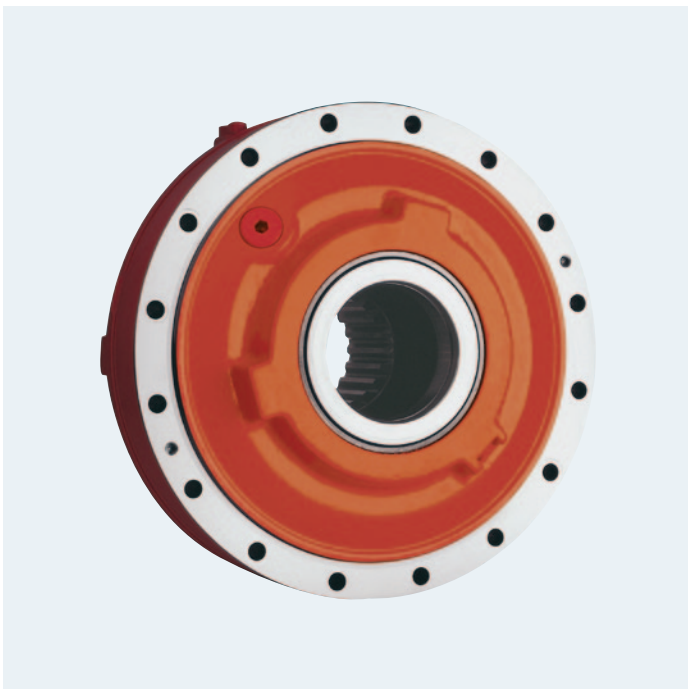

▲ Viking motor with optional free-wheeling function and extremely high start-up efficiency – ideal for constant tensioning

◀ Compact CA motor with low power-to-weight ratio

## Gears: The addition to the axial piston unit

The output torques of Rexroth planetary gears range between 9,5 and 340 kNm. Thus, rope pull forces between 50 and 725 kN can be reached. State of the art technologies, a very calm operation and an easy-to-maintain design are the main features of our winch drives. As an option, Rexroth may also supply the winch gears including the opposite support bearing.

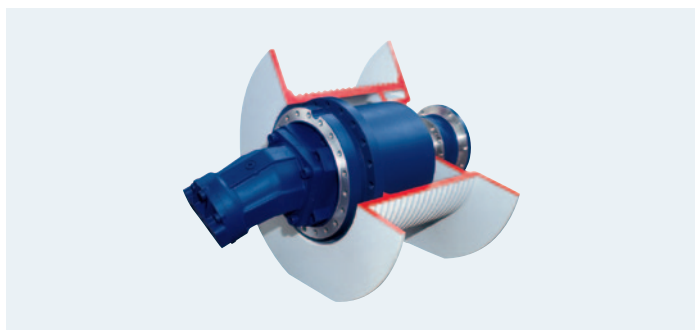

The planetary gear is integrated into the drum and allows for a compact design of the winch gear.

A very comfortable oil change and the simple installation are further advantages of the Rexroth planetary gears. All winch gears are equipped with an integrated multiple disk brake and may be combined / operated with a fixed displacement motor A2FM/E or a variable displacement motor A6VM/E.

# Brakes:

## Saving Space through Motor Attachments

All brakes feature a high power density and provide the drive system with additional safety. Each brake is available in three different versions, depending on the direction of braking, clockwise, counter-clockwise and double acting.



Multi-disc parking brakes (MDA brakes) are available for the two compact motors CA and CB. They are wet-type brakes. Here, the individual chambers are filled with oil. The advantage is that the braking capacity is not affected by external oil leakage. In addition, the brake can also be used as a dynamic emergency brake..



For the Viking motor, we offer a special safety hand brake that is approved by DNV. This brake will continue to hold your load in the event of a fault in the drive system. Moreover, it is resistant to aging, utilised as a parking brake and can be mounted directly to the Viking motor (with the outer surface of the motor being used as a braking surface). This ensures you a very compact and low-priced winch design.

# Winch Control: One Space-saving Block, Many Functions

We have extended our product range of winch control blocks. Our latest winch control block for ship winches is named 'DSE'. As an alternative, we offer two further solutions for winch control: HICWB and YMWCB.

Space on a ship is precious. Therefore, a control block must not take up too much space. For this reason, we offer DSE and HICWB as motor-mounted versions. This saves space and minimises costs by shortening mounting work and eliminating additional pipes. This design variant reduces the number of leakage points and, at the same time, maintenance requirements.

Depending on the selected type, the control block can be fitted with loadlowering valves, pressure relief valves, automatic brake release valves, load-sensing ports and a hydraulic or electric remote control. The modular construction kit system allows individual adjustments of the control blocks to perform the functions desired by the winch manufacturer. Moreover, they guarantee a sensitive and load-independent control of the winches.

The application fields for our winch control blocks are anchor, combined windlass and mooring winches. They are controlled mechanically, either by means of a hand lever, electrically, hydraulically or a combination thereof. The YM-WCB was developed specifically for operations with a variable displacement motor. With only one hand lever the motor can be adjusted for the functions of heaving, pay-out and mooring.

If the HICWB is used in an anchor winch, one specialty is that, with the help of a hand lever valve, the operator can determine a self defined break-away torque for the anchor.

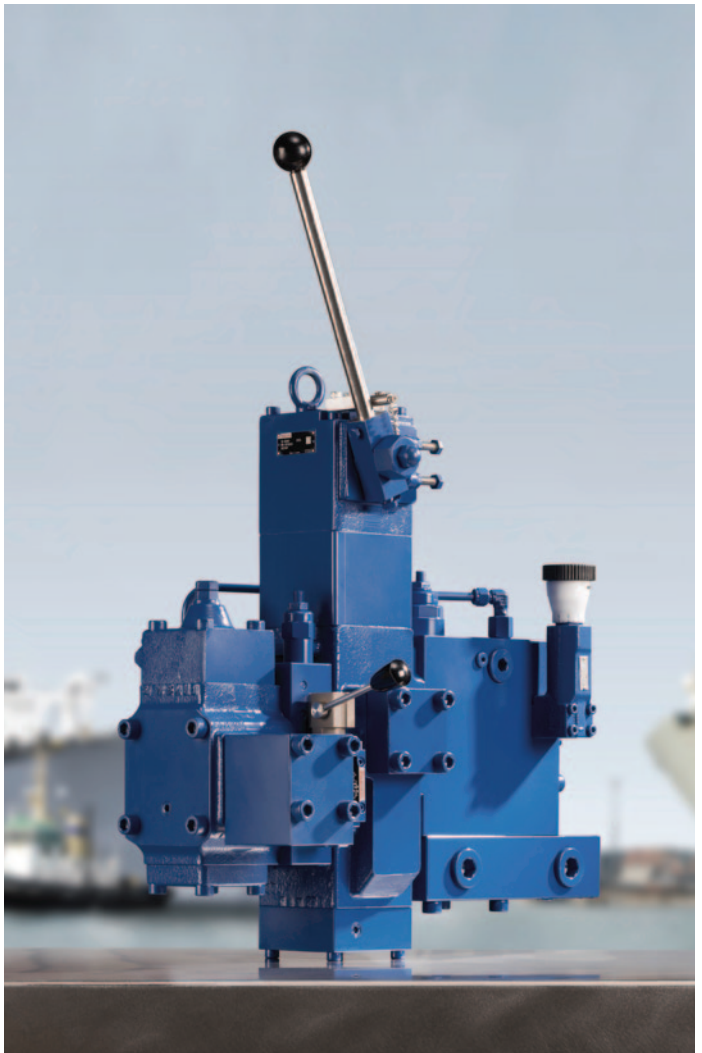

# Solutions for the Closed Circuit

Individual drives are mainly designed for operation in the closed circuit. Rotational speed and direction of the hydraulic motor are controlled by the amount and direction of the pump flow. The output torque of the motor depends on the system pressure.

This offers several advantages:

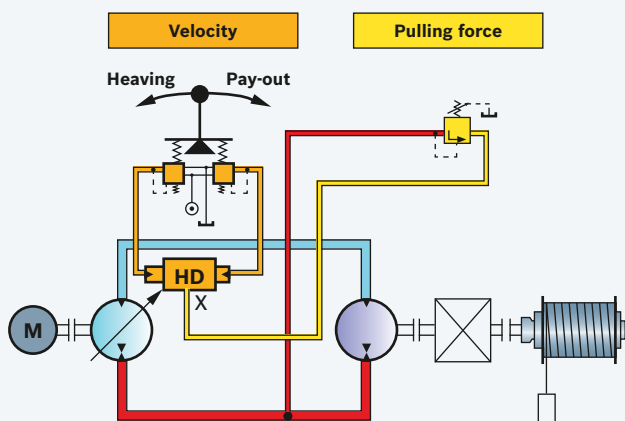

On the one hand, the pressure is only as high as necessary. Higher pressure is required briefly for start-up but can build up very easily. On the other hand, generatory braking is possible with only a small amount of heat being produced. A load-lowering valve is not required.

Mooring can be realised either hydraulically or electronically in the closed circuit. With hydraulic mooring, the pump is pilot operated through a pressure relief valve. In this case a by-pass is connected from the load side directly to the valve, and from there to the pump controller. If this line is too long, significant differences in the pulling force may in some cases occur between heaving and pay-out. If higher accuracy is required, electronic mooring may be the right solution. The load on the winch drum is sensed by means of a force transducer and fed to an electric control. From here, a proportional pressure relief valve is operated, which, in the case of hydraulic mooring, is connected to the load side and the pump controller. Due to the use of a proportional valve, any mooring pressure can be specified.

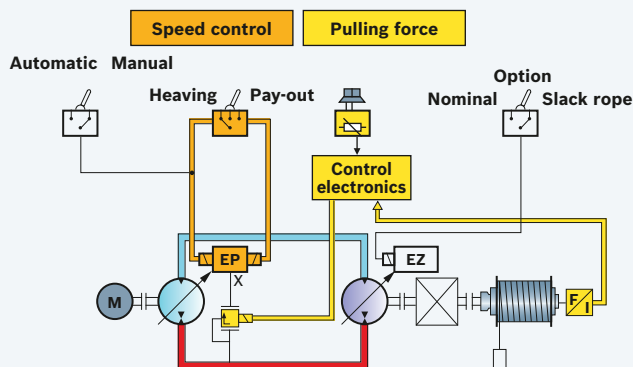

# Electronic Controls

Type RC BODAS control devices provide for both simple open-loop control and complex closed-loop control of winch drives, e.g. for controlling the mooring pressure. These devices were developed according to automotive technology standards, and guarantee top performance.



Necessary protection requirements with regard to ambient temperatures, tightness, shock, and vibration as well as electromagnetic compatibility (EMC) are met.

These controls offer you an extraordinarily high level of flexibility in your engineering work. Analog voltages, resistances, frequencies and switching information can be processed as input signals. Moreover, all graphical and text-based programming languages are specified according to the IEC 61131-3 standard.

The control comprises a safety concept, which offers maximum protection against operating errors and external faults. The standard programs of the device can be extended by application-related program packages, or be adapted specifically to the individual application.

All BODAS control devices are fitted with CAN bus interfaces for exchanging data with further bus nodes or electronics, e.g. RC, hand-held control devices, diesel engine injection, display.

# Rexroth Service: Your Key to Higher Productivity

Maximum system availability and the highest efficiency throughout the entire lifecycle of your machines and systems are the key factors that determine the productivity of your production processes. Rexroth offers comprehensive services that maximise your machine availability. Your advantage: higher productivity.



With our modular service portfolio, we can reduce the complexity and therefore the cost of maintenance and repair of your production equipment. Fast access to our qualified technicians is guaranteed. Due to our know-how in the field of drive and control technology, we meet your requirements quickly and reliably. We provide precise diagnostics and spare parts supplies at short notice. At the same time we cut costs through standardised processes and testing and inspection methods. We can do this because of our highly qualified staff in 80 countries around the world.



**Spare parts**



**Repairs**



**Field service**



**Modernization/retrofit**



**Preventive and predictive services**

On request, we keep your machines fit throughout their entire lifecycle with our preventive and predictive services, such as fitness checks or oil analyses. In cooperation with you we analyse the potential of modernisation/retrofit measures and realise them in a practical manner. Higher productivity, better energy efficiency and optimal safety standards reduce your operating cost significantly.

Take a look at our service portfolio – we offer tailored solutions that suit your individual requirements.

To get more detailed information, please visit  
[www.boschrexroth.com/service](http://www.boschrexroth.com/service)



**Bosch Rexroth AG**

Zum Eisengießer 1  
97816 Lohr, Germany  
Phone +49 9352 18-0  
Fax +49 9352 18-40  
[www.boschrexroth.com/hydraulics](http://www.boschrexroth.com/hydraulics)

**Find your local contact person here:**

[www.boschrexroth.com/addresses](http://www.boschrexroth.com/addresses)

**More information**

<http://www.boschrexroth.com/marine>

