



1800-OILSOL
1800-645765

<https://oilsolutions.com.au/>

sales@oilsolutions.com.au



BREVINI[®]

Motion Systems

Installation and Maintenance Manual

Hoisting and Recovery Winches

IMM-0003EN
September 2019

DISCLAIMER

The official language chosen by the Product manufacturer is English. No liability is assumed as a result of translations in other languages not in compliance with the original meaning. In case of conflicting language versions of this document, the English original prevails. Dana shall not be liable for any misinterpretation of the content here into. Photos and illustrations might not represent the exact product.

© Copyright 2019 Dana Incorporated

All content is subject to copyright by Dana and may not be reproduced in whole or in part by any means, electronic or otherwise, without prior written approval.

THIS INFORMATION IS NOT INTENDED FOR SALE OR RESALE, AND THIS NOTICE MUST REMAIN ON ALL COPIES.

INDEX

1	GENERAL INFORMATION	5
1.1	INTRODUCTION	5
1.2	AIM OF THIS MANUAL	5
1.3	WARRANTY AND TESTING	6
1.4	INFORMATION FOR PERSONNEL	6
1.5	HOW TO USE THIS MANUAL	6
1.6	REPRODUCTION AND COPYRIGHT	7
1.7	VERSIONS OF THIS MANUAL	7
1.8	DATE AND INDEX OF THE VERSION OF THE MANUAL	7
1.8.1	VERSION TRACKING	7
1.8.2	MODELS	7
2	PACKING, SHIPMENT, HANDLING, INCOMING GOODS PROCEDURES	8
2.1	PACKING AND SHIPMENT	8
2.2	INCOMING GOODS PROCEDURES	8
2.3	HANDLING THE WINCH WITHOUT PACKING	9
2.4	HANDLING	9
2.5	STORAGE	10
3	MACHINE DESCRIPTION AND SPECIFICATIONS	11
3.1	OPERATING PRINCIPLE	11
3.2	CONFIGURATION AND CONSTRUCTION TYPE	11
3.3	TECHNICAL REFERENCE STANDARDS	11
3.4	OPERATING ENVIRONMENTAL CONDITIONS	11
3.5	OPERATION IN CONTAMINATED ENVIRONMENTS	11
3.6	VIBRATION	11
3.7	NOISE	11
3.8	ATMOSPHERES WITH EXPLOSION AND/OR FIRE HAZARD	11
3.9	NOISE	11
3.10	REASONABLY FORESEEABLE MISUSE	12
3.11	PROHIBITION	12
4	INSTALLATION	13
4.1	RULES FOR CORRECT INSTALLATION	13
4.1.1	TABLE OF TIGHTENING TORQUES RECOMMENDED ACCORDING TO DOC. NPIO34	14
4.2	LUBRICATION	15
4.2.1	FILLING THE HYDRAULIC MOTOR	15
4.3	HYDRAULIC SYSTEM OIL	16
4.3.1	VISCOSITY CLASSIFICATION TABLE	16
4.4	CONNECTING THE HYDRAULIC SYSTEM TO THE WINCH	17
4.5	STANDARD "01" - "02" HYDRAULIC SYSTEM	18
4.6	ELECTRICAL MOTOR	18
4.6.1	EMERGENCY	18
5	START UP	19
5.1	SECURING THE ROPE	19
5.1.1	ROPE FASTENING	20
5.2	TESTING OF OPERATION	22
6	MAINTENANCE	23
6.1	ROUTINE MAINTENANCE	23
6.2	SPECIAL MAINTENANCE	23
6.3	SPECIAL MAINTENANCE OF THE NEGATIVE BRAKE	23
7	DISPOSAL	24
8	LIST OF RESIDUAL RISKS AND LIST OF RULES REGARDING WINCHES	25
8.1	HOISTING WINCHES	25
8.1.1	RESIDUAL RISKS	25
8.1.2	RULES	26
8.2	RECOVERY WINCHES	27
8.2.1	RESIDUAL RISKS	27
8.2.2	RULES	28

9	LIFTING AND RECOVERY WINCH ACCESSORIES	29
9.1	LIFTING	29
9.2	RECOVERY	29
10	APPENDIX A - ROPES - PULLEYS AND DRUMS	30
10.1	USE AND MAINTENANCE OF ROPES	30
10.1.1	MAIN FEATURES	30
10.1.2	PROCEDURES PRIOR TO USE	30
10.1.3	MEASURING THE ROPE DIAMETER	30
10.1.4	HOW TO HANDLE THE ROPE	31
10.1.5	DIRECTION FOR WINDING THE ROPE	32
10.1.6	ROPE SELECTION	32
10.1.7	ROPE ANCHORING ONTO THE DRUM AND WINDING DIRECTION	33
10.1.8	ROPE FITTING AND MAINTAINING	33
10.1.9	ROPE LUBRICATION	33
10.1.10	BLOCKS STABILITY DURING ROTATION	33
10.1.11	ANGLE OF DEVIATION	34
10.1.12	CRITERIA FOR TARGETED ROPE CONTROL	36
11	APPENDIX B - NOTIONS ON TOWING AND RECOVERY	41
12	CONVERSION TABLES	43
12.1	BASE UNIT	43
12.2	LENGTHS	43
12.3	MOMENT	43
12.4	AREA	43
12.5	VOLUME	44
12.6	TEMPERATURE	44
12.7	DENSITY	44
12.8	FORCE	44
12.9	MASS	44
12.10	SPEED	45
12.11	PRESSURE	45

1 GENERAL INFORMATION

1.1 INTRODUCTION

Dana Motion System would like to thank you for choosing one of its products and is pleased to welcome you as a Customer. We are confident you will find using this winch very satisfactory.

1.2 AIM OF THIS MANUAL

This manual aims at giving the users of our hoisting and recovery winches all the necessary information in order to install, operate and maintain correctly the winches in compliance with the safety limits provided for by the standards in force.

In order to facilitate the understanding of this manual, we are listing the terms and symbols used below:

Danger Area:

area in or close to the machine where the presence of an unprotected person constitutes a risk for the health and safety of the person himself.

Unprotected Person:

any person who is completely or partially within a danger area.

Operator:

a person in charge of installation, start up, adjustment, maintenance and cleaning of the machine as a whole.

Qualified Technician:

a trained person in charge of special maintenance or repairs requiring particular expertise concerning the machine, including its operation, its safety devices and how they operate.

Stating:

a - Serial number of the winch

b - Model code

c - Type of winch / description

d - Construction year - Bar code

e - Weight

This information can be found on the name plate attached to the winch.

NOTE:

One among the designs below can be found on the winch according to the serial number release date.

 CAUTION
Standards for the prevention of accidents for the Operator and the Qualified Technician.

 WARNING
Possibility of machine damage and/or damage to machine parts.

IMPORTANT:

ADDITIONAL INFORMATION RELATING TO THE PROCESS IN QUESTION.

NOTE:

Useful or important information.

Please contact Dana Motion System in case of any doubt, or should this manual be damaged or misplaced.

- TELEPHONE: +39 0522 9281
- FAX: +39 0522 928200

		Via Luciano Brevini 1/A 42124 Reggio nell'Emilia/Italy Tel. +39 0522 9281	
Motion Systems		CE	
SN	a	Bar code	d
Item	b		
Family / Out / i / / / Ir.			
c			
Info	Rope diameter mm	Rope strength N/mm	
Power kW	Volt	Hz	FEM
Max pressure bar	Max oil flow l/min	Weight kg	e
Max line pull first layer kg	Speed rope first layer m/min		
Max line pull top layer kg	Speed rope top layer m/min	layer	layer

		Via Luciano Brevini 1/A 42124 Reggio nell'Emilia/Italy Tel. +39 0522 9281	
Motion Systems		CE	
S.N.	a	Bar code	d
Item	b		
Description			
c			
Info			
Rope diameter (mm)	Min. MBL (kN)	Peak pressure (bar)	Oil flow (l/min)
Power (kW)	Voltage (Volt)	N.poles	
Layer	Max line pull (kg)	Lifting of Personnel (kg)	Rope speed (m/min)
			e

1.3 WARRANTY AND TESTING

Dana Motion System guarantees its products are free from any material or manufacturing defects for the period stated in the supply agreement or order confirmation.

This warranty will be considered null and void should the cause of the fault or anomaly be deemed the result of incorrect or unsuitable application of the product and in case of failure to comply with start up, which must be done within six (6) months of the date of shipment.

1.4 INFORMATION FOR PERSONNEL

All employers must ensure that personnel are informed about the following issues relating to safe operation of the winch:

- Accident risks.
- Devices designed for operator safety.
- General rules for the prevention of accidents or rules provided for by international directives and by the legislation of the country where the winch is to be used.

However, Operators and Qualified Technicians must safeguard full compliance with standards for safety and prevention of accidents in the country where the winch is to be used.

Both Operator and Qualified Technician must be acquainted with the features of the winch before starting on a job and must have read this manual in full.

Modifying or replacing winch parts without due authorisation issued by Dana Motion System in writing, could result in damage to things or injury to people. In such case, the winch manufacturer is no longer liable for any civil or criminal damages.

1.5 HOW TO USE THIS MANUAL

We have made it easier to consult this manual by adding a general index on page 3. This will help you to find the topic you are looking for.

The chapters are arranged in a hierarchy structure to facilitate the search for the information required.

1.6 REPRODUCTION AND COPYRIGHT

All rights reserved by Dana Motion System

The structure and the contents of this manual may not be copied, even partially, without prior authorisation issued by Dana Motion System in writing.

1.7 VERSIONS OF THIS MANUAL

This manual is subject to review further to application and operation changes.

1.8 DATE AND INDEX OF THE VERSION OF THE MANUAL

The indications and the date of this version of the manual are published on the last page of the cover.

1.8.1 VERSION TRACKING

File name	Rev.	Date	Description
IMM-0003 Winches (9006661)	00		Document issued
IMM-0003EN Rev.01 Hoisting and recovery winches	01	24/09/2019	Changed layout

1.8.2 MODELS

Hoisting and recovery winches

2 PACKING, SHIPMENT, HANDLING, INCOMING GOODS PROCEDURES

2.1 PACKING AND SHIPMENT

Winches are packed and shipped in crates or on pallets on a case-by-case basis.

2.2 INCOMING GOODS PROCEDURES

When the winches arrive, check that the items supplied match the items stated in the order and that the packing and contents have not been damaged during transport

⚠ CAUTION

The packing strap is sharp. It may hit the Operator when cut.

The packing materials should be removed as follows:

- cut the packing straps with snips (take care as the ends could hit the Operator).
- cut away, or pull off, the surrounding packing material.
- take the winches off the pallets.

If you notice any damage, faults or missing items, please notify Dana Motion System without delay.

- TELEPHONE: +39 0522 9281
- FAX: +39 0522 928200

Stating:

- a** - Serial number of the winch
- b** - Model code
- c** - Type of winch / description
- d** - Construction year - Bar code
- e** - Weight

This information can be found on the name plate attached to the winch.

NOTE:

One among the designs below can be found on the winch according to the serial number release date.

		Motion Systems		Via Luciano Brevini 1A 42124 Reggio nell'Emilia/Italy Tel. +39 0522 9281	
SN	a	Bar code	d		
Item	b				
Family / Out / i / In	c				
Info	Rope diameter (mm)	Rope strength (N/mm)			
Power (kW)	Volt	Hz	FEM		
Max pressure (bar)	Max oil flow (l/min)	Weight (kg)	e		
Max line pull first layer (kg)	Speed rope first layer (m/min)				
Max line pull top layer (kg)	Speed rope top layer (m/min)				

		Motion Systems		Via Luciano Brevini 1/A 42124 Reggio nell'Emilia/Italy Tel. +39 0522 9281			
S.N.	a	Bar code		d			
Item	b						
Description	c						
Info	Rope diameter (mm)	Min. MBL (kN)	Peak pressure (bar)	Oil flow (l/min)	Power (kW)	Voltage (Volt)	N.poles
Layer	Max line pull (kg)	Lifting of Personnel (kg)	Rope speed (m/min)	FEM	e		

NOTE:

The Customer is responsible for the disposal of the packing materials and must ensure this is done in compliance with the regulations in force in the country where the winch is to be used.

PACKING, SHIPMENT, HANDLING, INCOMING GOODS PROCEDURES

2.3 HANDLING THE WINCH WITHOUT PACKING

⚠ CAUTION

Before taking the winch out of its packing, secure it with suitable lifting accessories (protect any painted surfaces) so that it will not slip or overturn.

Before handling the winch, remove any wooden blocks inserted inside the packing to safeguard stability during handling and transport.

When lifting the winch, take care that the weight is distributed evenly during handling.

⚠ CAUTION

Do not lift the winch up by the motor.

2.4 HANDLING

⚠ CAUTION

When moving pallets, use vehicles suitable for the type of packing and offer sufficient carrying capacity for the job in question.

Weight of winch indicated by the letter “E”.

DANA BREVINI Motion Systems		Via Luciano Brevini 1A 42124 Reggio nell'Emilia/Italy Tel. +39 0522 9281		CE
SN	a	Bar code		
Item	b			d
Family / Out / i / / / Is	c			
Info		Rope diameter mm	Rope strength N/mm	
Power kW	Volt	Hz	FEM	
Max pressure bar	Max oil flow l/min	Max line pull first layer kg	Speed rope first layer m/min	Weight kg e
Max line pull top layer kg	Speed rope top layer m/min	layer	layer	layer

DANA BREVINI Motion Systems		Via Luciano Brevini 1/A 42124 Reggio nell'Emilia/Italy Tel. +39 0522 9281		CE
S.N.	a			
Item	b			d
Description	c			
Info				
Rope diameter (mm)	Min.MBL (kN)	Peak pressure (bar)	Oil flow (l/min)	Power (kW)
				Voltage (Volt)
				N.poles
Layer	Max line pull (kg)	Lifting of Personnel (kg)	Rope speed (m/min)	FEM
				Weight (kg) e

- Do not tip or overturn when lifting or moving.
- If items are moved with a fork lift truck, make sure the weight is distributed evenly on both forks
- If items are moved using a hoist, make sure the weight is distributed evenly and use lifting accessories in the sling, which are approved in compliance with legal standards.
- For items shipped on pallets, make sure that the lifting accessories do not damage the winch.
- If necessary, place suitable wooden blocks under the item to facilitate the use of lifting accessories.

⚠ CAUTION

When lifting the item and putting it into position, avoid impacts and violent knocks.

2.5 STORAGE

If the winch is to be stored for a 'temporary' period, or for a period exceeding six months, follow the instructions below after completing functions testing:

- Completely fill the reduction gear section and the hydraulic motor with oil (for the use of oils, see the section on "4.2 Lubrication, page 15" and "4.3 Hydraulic system oil, page 16").
- Close all the open holes or connections using the appropriate plugs or caps.
- Store in a safe, dry place, without significant variations in temperature and humidity levels.

CAUTION

If the storage period is to be longer than six months, the efficiency of the rotating seals will deteriorate (periodic visual checks are recommended; if leaks are observed, the seals should be replaced. Contact the Dana Motion System technical service as indicated in paragraph "2.2 Incoming goods procedures, page 8").

- Avoid laying the winches on top of one another. Should it be necessary to do so, use appropriate separators able to withstand the load.
- Do not place on top of items material that could damage them.
- Do not store the item in close proximity to areas of transit.
- Do not rest the winch directly on the floor.

3 MACHINE DESCRIPTION AND SPECIFICATIONS

3.1 OPERATING PRINCIPLE

In its various configurations, this winch is designed for lifting or recovery jobs.

3.2 CONFIGURATION AND CONSTRUCTION TYPE

The configuration of the winch is defined by contract.

The winch is basically composed of:

- Drum.
- Supporting structure.
- Epicyclical reduction gear.
- Fail-safe negative brake.
- Valve for blocking and controlling descent or recovery.
- Hydraulic motor.
- Accessories.

3.3 TECHNICAL REFERENCE STANDARDS

The technical documentation file is stored in the Dana Motion Systems Technical Department. It contains the engineering documents, the standards applied, calculations, verifications of gear systems, references of material, test certificates, dimensions, assembly drawings and lists of spare parts.

3.4 OPERATING ENVIRONMENTAL CONDITIONS.

To ensure correct winch operation, it must be used in places where the room temperature is between -10°C and $+40^{\circ}\text{C}$ and relative humidity is maximum 50%. Contact Dana Motion System prior to use in case of other operating temperatures.

3.5 OPERATION IN CONTAMINATED ENVIRONMENTS

Should the winch be used in corrosive situations, with coarse pollutants such as sand, sludge, sawdust or extremely fine dust, clean the winch with water or appropriate liquid for the type of pollutants, in order to prevent deposits, which could damage important parts such as bolts and screws, rings and washer seals.

It is important that maintenance is carried out in line with an appropriate schedule and using appropriate methods in order to prevent excessive wear of the winch, checking beforehand that there is no damage to the varnished surfaces.

3.6 VIBRATION

When operating conditions comply with the instructions for correct use provided in this manual, vibration deriving from normal operation will not result in any hazardous situations. Unusual vibration may indicate malfunctions, the operator should stop the machine immediately and notify Dana Motion System.

3.7 NOISE

This winch is designed and manufactured so as to reduce the noise level at source. Dana Motion System informs operators with regard to the issue of winch noise so that they may take appropriate measures according to the operating environmental conditions (for example: in the presence of reverberating parts or other noise sources in the vicinity).

3.8 ATMOSPHERES WITH EXPLOSION AND/OR FIRE HAZARD

This winch is not designed to be used in an explosive or potentially explosive atmosphere.

Should such operating conditions be envisaged, it is essential you contact Dana Motion System.

3.9 NOISE

This winch is designed and manufactured so as to reduce the noise level at source.

The acoustic pressure level is less than 70 dB (A).

A noise increase can indicate a malfunction of the machine.

3.10 REASONABLY FORESEEABLE MISUSE

- The following may come under the heading of “reasonably foreseeable misuse” of the winches for lifting and recovery:
 - all those operations that go beyond the characteristics defined on the name plate of the winch.
 - the use of the winches for lifting or recovery operations not identified in the rules for correct operation.
 - the use of the winches for lifting or recovery in the presence of obstacles liable to interfere with the normal operations they are designed to carry out.
- Recovery winches may not be used as lifting winches.

3.11 PROHIBITION

- Winches for lifting or recovery may not be used for the direct or indirect transport or lifting of persons.
- Winches for lifting or recovery may not be used in all the situations already mentioned in this usage and maintenance manual.
- Recovery winches may not be used as lifting winches.
- Winches for lifting or recovery may not be used to carry out lifting or recovery operations when the drum is locked.
- It is forbidden to carry out any lifting or recovery operations liable to cause risks to, first and foremost, the safety of workers, and, secondly, to the vehicles and equipment connected with the lifting or recovery operations.
- It is forbidden to tamper the machine.
- Hoisting and recovery winches shall not be used with synthetic rope.

4 INSTALLATION

4.1 RULES FOR CORRECT INSTALLATION



 **CAUTION**

The winch must be installed by Operators and Qualified Technicians.

The winch must be assembled onto the support prepared by the user using its interface. It must be installed onto a rigid structure with an even surface, secured using good quality bolts and screws for final application. Screws should be used with resistance class 8.8 or 10.9 and with torque according to standards in force, as indicated in the table below, and the use of washers under the head of the screws is recommended.

INSTALLATION

4.1.1 TABLE OF TIGHTENING TORQUES RECOMMENDED ACCORDING TO DOC. NPIO34

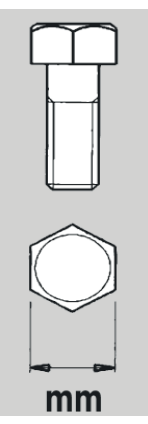
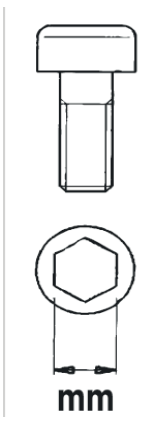
				SCREWS CLASS ¹					
				8.8			10.9		
				Recommended tightening torques [N·m]					
				TARGET	MIN	MAX	TARGET	MIN	MAX
M6	1	10	5	10.4	9.8	10.6	15.3	14.4	15.6
M8	1.25	13	6	25	23.5	25.5	37	34.8	37.7
M10	1.5	16	8	50	47	51	73	69	74
M12	1.75	18	10	86	81	88	127	119	130
M14	2	21	12	137	129	140	201	189	205
M16	2	24	14	214	201	218	314	295	320
M18	2.5	27	14	306	288	312	435	409	444
M20	2.5	30	17	432	406	441	615	578	627
M22	2.5	34	17	592	556	604	843	792	860
M24	3	36	19	744	699	759	1060	996	1081
M27	3	41	19	1100	1034	1122	1570	1476	1601
M30	3.5	46	22	1500	1410	1530	2130	2002	2173
M33	3.5	50	24	1980	1861	2020	2800	2632	2856
M36	4	55	27	2540	2388	2591	3600	3384	3672

¹ Class according ISO898-1:2009.

NOTICE

The screws should be long enough to properly connect the structure of the winch itself and the structure it is laid on or in.

CAUTION

The final manufacturer is charged with installing a maximum pull or torque control for winches with SWL \geq 1000kg or 40000N·m.

CAUTION

The final manufacturer is charged with installing protection covers or guard, in case the machine is easily reachable/accessible.

NOTE:

For correct assembly, use the holes provided on the winch/application interface.

4.2 LUBRICATION

When the winch is supplied with oil, the correct amount of lubricant, as stated in the winch's specifications sheet is used. The oil is ISO VG150 according to ISO 3448.

In case the winch is supplied without oil, the user must carry out correct filling before starting the machine.

The first oil change must be done prior to completion of 50 hours of winch operation: initial running in period. After this, every 500 hours of winch operation.

For controlling, topping up and changing the oil, use the plugs provided for this purpose, as shown in the specifications sheet. The washer seals under the plugs should be changed every time they are unscrewed for such work. Lubricant should be changed when the oil is hot in order to prevent sludge formation. When changing the oil, you should also clean inside the reduction gear using cleaning liquid suitable for this purpose, and recommended by lubricant manufacturers. You should control the lubricant level every 20 days, regardless of the number of hours of operation.

NOTE:

Prior to any use of the winch, check that the oil is present and with the correct amount.

4.2.1 FILLING THE HYDRAULIC MOTOR

All installation orientations (and also for intermediate orientations not shown) are to be mounted after the optimum filling orientation. The housing is to be filled from S1 or S2 drain port with pre-filtered oil. At this point in time, all other ports must be plugged. Ports which will be required later must be closed by means of pipe bends or non return valve. This prevents air entering the unit when turning it into its installation orientation. When installing the unit below the minimum oil tank, it should be noted, that the ports are then only opened after the tank has been filled and when the unit is below oil level. The sequence of operations to be done are shown in the below drawing. If the motor is already installed into position, it is possible to fill the casing following the directions shown below. While doing this, it is important to avoid any contamination of the casing with dirt or other contaminants. First oil change to be made after approximately 500 hours of operation, filtering elements must be replaced first time after 50 hours for preliminary circuit cleaning and the every 500 hours; subsequently change oil ever 2000 hours. Such intervals should be reduced when the filter clogging indicator shows that the cartridge is clogged or when the system works in a heavily polluted environment.

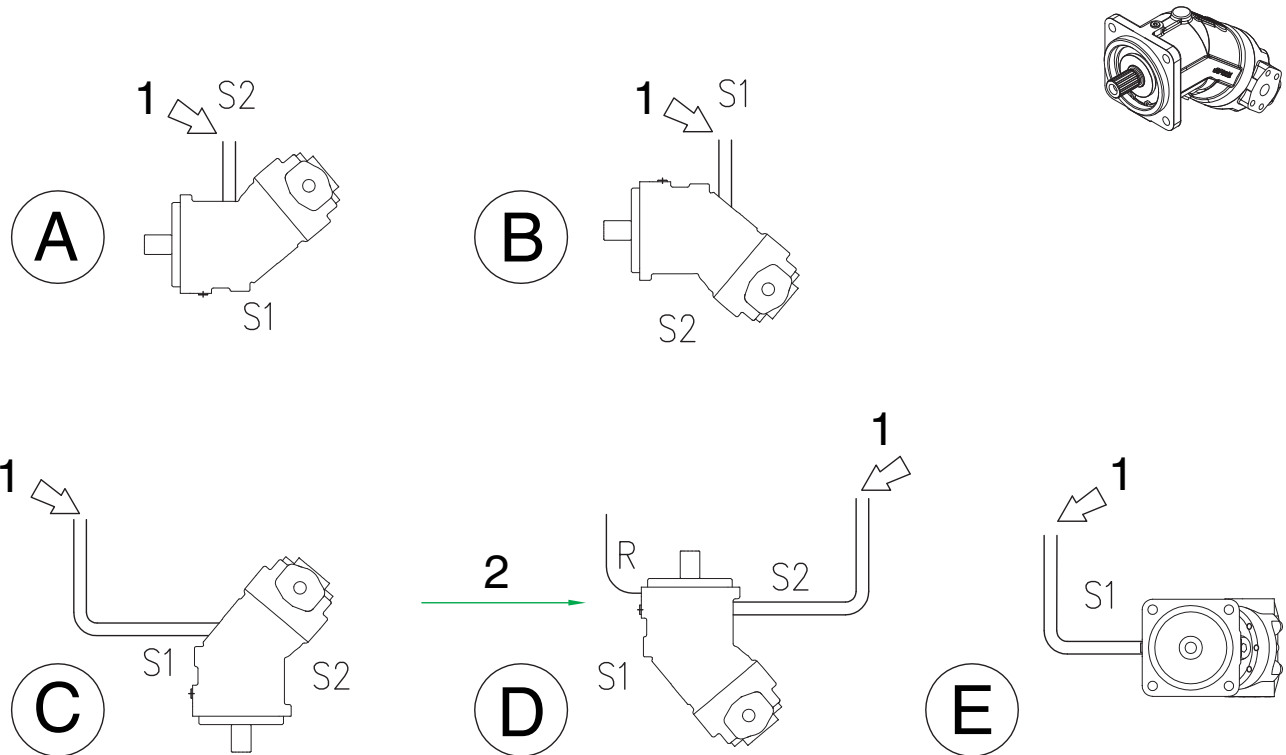

- 1 - Oil
- 2 - Air Bleed

INSTALLATION

4.3 HYDRAULIC SYSTEM OIL

For the supply of the winch's hydraulic motor, use mineral oil with wearproof additives and VG 46 index of viscosity. It is essential that you use 10 micron hydraulic oil filters on the motor inlet in order to safeguard correct operation and satisfactory duration of the hydraulic motor, the fail-safe negative brake, the selector valve for release of the brake and of the valve for control of the load descent.

4.3.1 VISCOSITY CLASSIFICATION TABLE

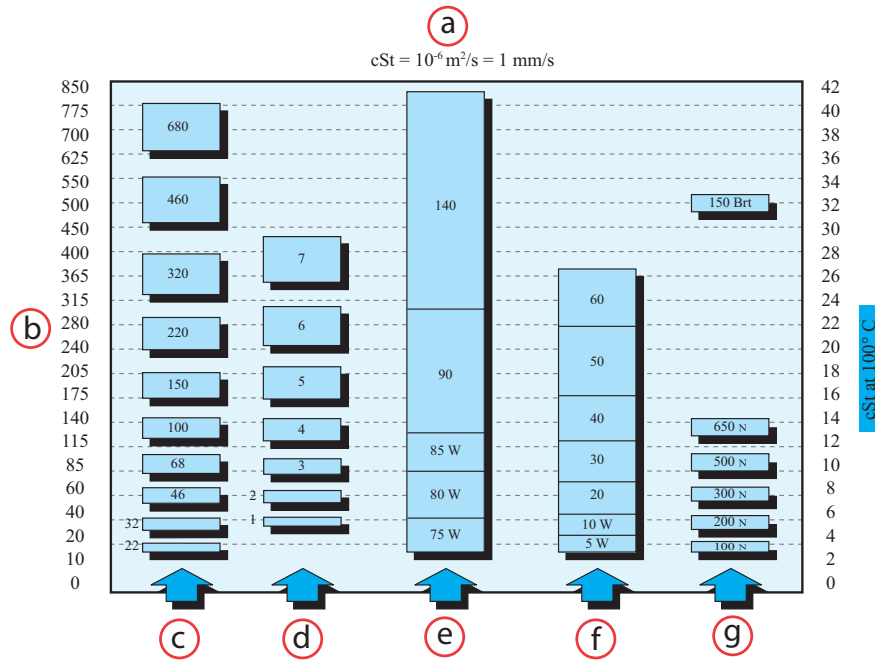

- a** - Viscosity Classification
- b** - cSt at 40° C
- c** - ISO VG
- d** - AGMA No.
- e** - SAE number transmission
- f** - SAE Number motors
- g** - SUS (basic oils)

4.4 CONNECTING THE HYDRAULIC SYSTEM TO THE WINCH

The winch must be connected to the hydraulic system by means of three pipes: two of these handle its supply and the third one is connected directly to the hydraulic system's tank for draining the motor, when necessary (the dimensions and the specifications of the couplings for connecting the pipes to the hydraulic motor are stated in the specifications sheet for each winch). The internal diameter of the pipes must be adequate so as to prevent the loss of load and unsatisfactory counter pressure leading to an increase in pressure throughout the whole system.

NOTE:

Viewing the machine from the motor side, 01 means that the lifting is in clockwise direction, 02 means that the lifting is in counter clockwise direction.

Recommended hydraulic layout with direct motor drain into the tank

Lifting code= 01

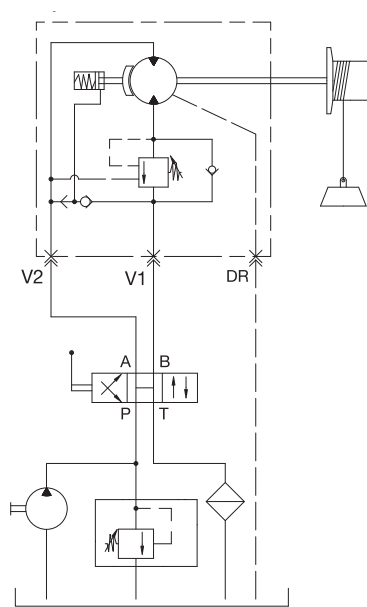

Lifting code= 02

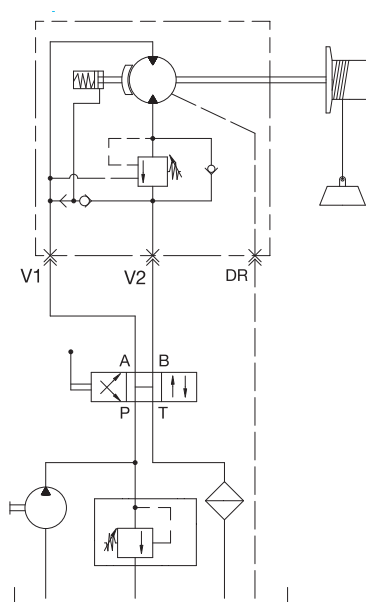

INSTALLATION

4.5 STANDARD “01” - “02” HYDRAULIC SYSTEM

See "4.4 Connecting the hydraulic system to the winch, page 17"

CAUTION

When the system is stationary, the pressure needed for the flow of oil through the pipes, must not exceed three (3) bar. (Place quick-couplers on the pipes for the application of control gauges).

WARNING

Use oil-pressure winch control distributors, which have V1-V2 drainage lines in neutral position (configuration H), in order to prevent the negative brake from being accidentally released by any hydraulic pressure remaining in the pipes when the winch is stationary.

WARNING

During normal winch operation, the negative brake will be automatically released by means of the valve or the motor itself when the motor is started up and must lock again when the motor stops running.
To release the brake, pressure is taken from the supply line to the motor. When the winch stops, in order to allow the negative brake to lock again, the remaining pressure must not be above three (3) bar in the two supply lines when the distributor lever is placed in the centre.

DANGER

The lifting of a load applied to the winch rope must never make use of the hydraulic jib of the crane where the winch is installed. In this case, the pressure relief valve is not able to protect the winch from very dangerous overloads.
Tampering with the pressure relief valve for loads in excess of those allowed is PROHIBITED.

4.6 ELECTRICAL MOTOR

This usage and maintenance manual is devoted mainly to lifting and recovery winches whose main motor is composed of hydraulic rotary actuators; for other types of motor, consult the Dana Motion System technical service.

4.6.1 EMERGENCY

The machine is not equipped with emergency device. The installer must provide an emergency device covering the entire machine according to its total risks assessment and the type of power supply used. The emergency device must stop the machine safely.

5 START UP

CAUTION

Before starting up the winch for the first time, check the following:

- The level of the lubricant is correct.
- All bolts and screws are securely tightened.
- The hydraulic system complies with the specifications listed in the relative section.
- The direction of drum rotation is correct.
- In order to check the direction of drum rotation, operate the winch without load and make sure the lifting motion is the same as the direction of rope winding on the drum.

5.1 SECURING THE ROPE

NOTE:

The winch is normally supplied without rope wound on the drum.

The assembly of the rope must be carried out by an Operator or Qualified Technician according to the instructions provided by the rope manufacturer.

IMPORTANT:

READ CAREFULLY THE RECOMMENDATIONS IN APPENDIX "A".

The winch equipped with rope can have different types of rope fasteners depending on the application. They can be outside or inside the drum with screw, wedge and clamp systems. Make sure that the rope together with its fasteners is firmly anchored and correctly pretensioned.

IMPORTANT:

DO NOT DAMAGE THE ROPE END, PLEASE FOLLOW "10 APPENDIX A - ROPES - PULLEYS AND DRUMS, PAGE 30". ALL THE OPERATION MUST BE DONE WHILE THE WINCH IS NOT WORKING.

START UP

5.1.1 ROPE FASTENING

IMPORTANT:

HANDLE THE FREE END OF THE ROPE WITH ADEQUATE PROTECTIONS AND EQUIPMENT. BE CAREFUL NOT TO DAMAGE THE ROPE BY FOLLOWING THE ADVICE GIVEN IN APPENDIX "A". ALL OPERATIONS MUST BE CARRIED OUT WHILE THE WINCH IS NOT WORKING AND PROCEED WITH CAUTION DURING THE DRUM ROTATION FOR POSITIONING.

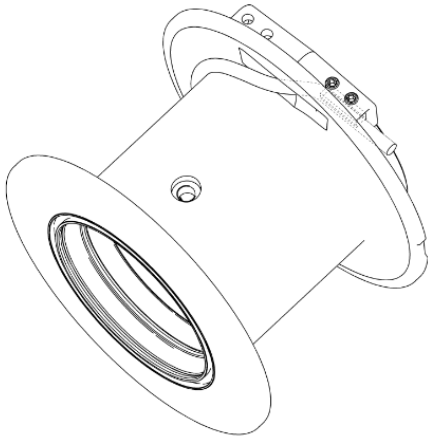

FIGURE 1: Insert the rope into the slot on the drum flange and check the direction of the winch rotation, tighten the screw to defined torque.

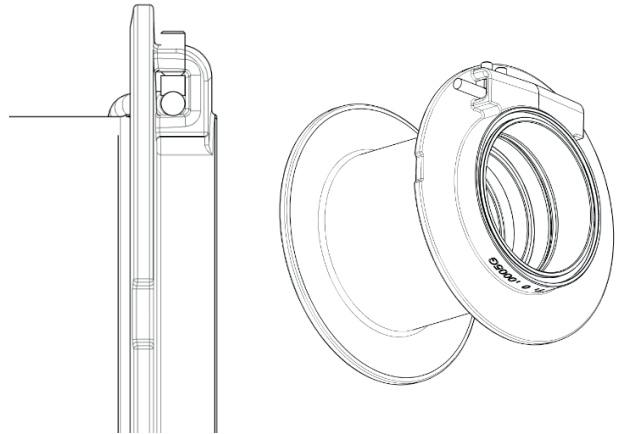

FIGURE 3: Check the free passage of the rope in the drum pocket, place the plate in the upper area between the rope and the pocket, tighten the screws ensuring the fixed torque, the length of the rope that can go out is 2 times the diameter.

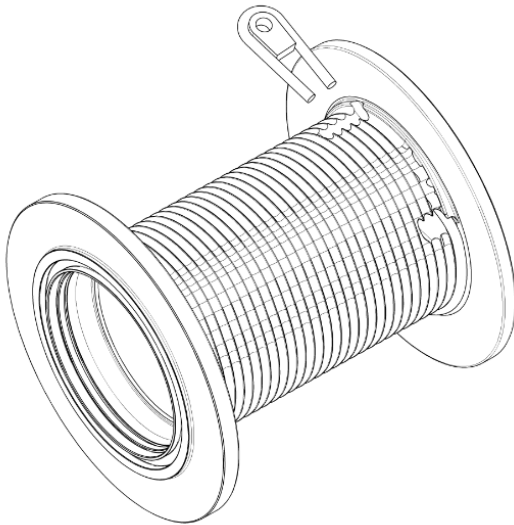

FIGURE 2: Insert the rope into the slot inside the drum and check the direction of the winch rotation.

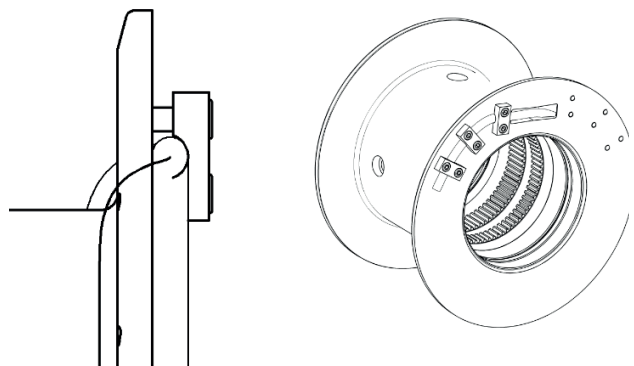

FIGURE 4: Check that the rope goes through the centre of clamps and tighten the screws ensuring the fixed torque; check that the rope is housed in its groove and is placed on the drum flange, the length of the rope that can go out is 2 times the diameter of the last clamp.

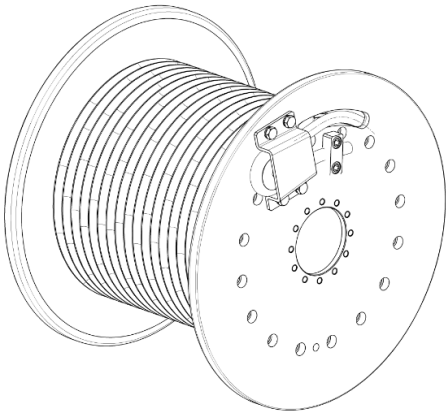

FIGURE 5: Fold the rope around the wedge, block the wedge in the pocket and pull the section of rope housed on the drum by always ensuring a free portion equal to 2 times the diameter of rope in the opposite side or after the rope clamp.

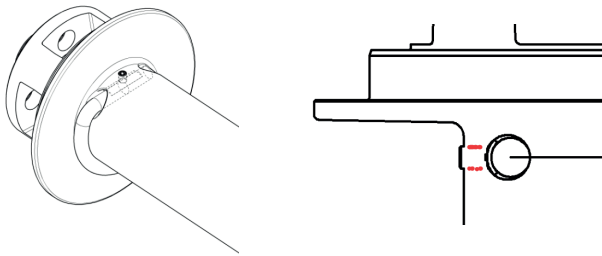

FIGURE 6: Check the free passage of the rope in its slot, place the plate in the upper area between the rope and the slot, tighten the screw ensuring the fixed torque, the rope must not go out on the opposite side.

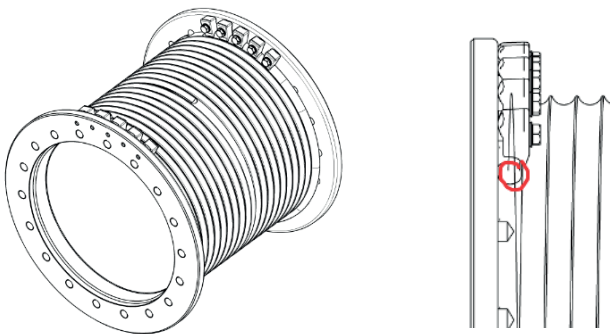

FIGURE 7: Place the rope inside the drum flange, ensure the correct position of clamps and tighten the screws at the fixed torque.

START UP

5.2 TESTING OF OPERATION

NOTE:

All data relating to pressure, hydraulic oil flow and speed are listed in the table of winches technical specifications and on the name plate of the winch

When starting up, you must run the winch without a load in both directions of rotation for about ten minutes.
For the first time, only lift a small load to a height of about one meter and check that the brake is working correctly.
Make sure you are able to control the descent and that the pressure in the return line does not exceed 3 bar when the winch is stationary.
If provided, control that all the limiting devices both electrical and hydraulic function correctly.

NOTE:

The winch recovery / hoisting is designed for lifting or recovery loads. Any use with loads exceeding the specifications listed in the specifications sheet is considered IMPROPER. Using the winch for lifting or transporting people is strictly prohibited.

IMPORTANT:

THE PERSON IN CHARGE OF THE FINAL APPLICATION OF THE WINCHES IS RESPONSIBLE FOR THEIR SAFE EMPLOYMENT, INCLUDING ISSUING THE LIST OF FURTHER RISKS AND THE APPLICATION OF THE SAFETY DEVICES REQUIRED BY STANDARDS IN FORCE.

CAUTION

It is important to bear in mind that starting up any type of appliance inevitably entails a certain amount of risk. Therefore, every single action should be awarded maximum attention and concentration.

6 MAINTENANCE

NOTE:

Maintenance may be classed as “routine” or “special” maintenance.

CAUTION

All maintenance work, whether routine or special, must be carried out in the safest conditions, in places equipped for the purpose, offering perfect ventilation and lighting.

6.1 ROUTINE MAINTENANCE

The Operator is in charge of routine maintenance, including the following tasks:

- Changing the reduction gear oil as instructed in section "4.2 Lubrication, page 15" after no more than 50 hours of operation (running in), or after this, every 500 hours of winch operation.
- Every time the machine is subjected to a normal maintenance (oil change, rope change, ...), control the functionality of all the limiting devices if provided.

Regardless of the type of work the winch is used for, check the status and the level of lubricant on a regular basis and top up when necessary. Top up the amount of grease in the drum support transmission bearing when necessary, every month.

NOTE:

We recommend keeping a file for each winch; this should be duly filled in and updated every time maintenance work is carried out.

6.2 SPECIAL MAINTENANCE

WARNING

Dana Motion System does not allow the opening of the hydraulic motor or any work on the negative brake (residual risk). Dana Motion System does not allow the opening of the reduction gear for any reason except for routine maintenance.

Contact Dana Motion System if necessary.

- TELEPHONE: +39 0522 9281
- FAX: +39 0522 928200

6.3 SPECIAL MAINTENANCE OF THE NEGATIVE BRAKE

After 1000 hours of winch operation (with average operating cycles at 60% nominal load) a full service of the negative brake is mandatory. This work must be done by Dana Motion System or by an authorised service centre.

7 DISPOSAL

CAUTION

Disposal must be carried out by a Qualified Technician.

NOTE:

As different methods of disposal are required in different countries, you must comply with the requirements provided for by the laws and regulations provided for by the Institutions in charge in each country.

The winch must be transported to a suitable place for the dismantling of its various parts. Before starting work, make sure the reduction gear and hydraulic motor areas have been emptied of the relative liquids (oils) they contain. Store these in suitable containers separated by type.

Dismantle all the various parts of the unit, taking extreme care with the negative brake inside which there are a series of pre-loaded elastic springs.

Separate and store the different types of materials so they can be sent for waste recycling or disposal.

8 LIST OF RESIDUAL RISKS AND LIST OF RULES REGARDING WINCHES

8.1 HOISTING WINCHES

8.1.1 RESIDUAL RISKS

Risk	Description of the dangerous situation	Solutions adopted
Exceeding the maximum load, breakage and overturning.	Usually the machine is not equipped with a maximum load limit because said limit very much depends on the type of application used. When installing the maximum load device, the installer must take account of the conditions in which the winch is expected to be used. In addition, a safety system must be set in place in order to ensure the vehicle the winch is installed on cannot be overturned, in other words the overloading of the machine. All the tests requested (maximum load, overturning) must also be carried out.	Information in the manual
Loss of stability.	The machine must be properly fixed by the installer.	Information in the manual.
Danger of crushing during transport operations.	During transport, lifting and handling, the machine may fall. In addition, check that the packaging is in good condition and provided with a strap.	Instruction manual; training to be provided to operators in charge of transport, lifting and handling. The operations must be carried out at low speed, ensuring loads are balanced. Also check that the strap is present.
Wrong choice of rope. Rope blocked incorrectly.	The rope must be chosen in accordance with the loads and class of the winch, and must be fixed correctly, otherwise the load will be lost.	Information in the manual.
Risk due to moving parts. Guards not installed or installed incorrectly.	The operator may come into contact with moving parts.	Information in the manual regarding the compulsory installation of protective casing by the installer (where necessary).
Moving parts of the drive.	Incorrect assembly of moving parts, causing the risk of breakage or malfunctioning of the machine.	Information in the maintenance instruction manual. Internal assembly diagrams.
Wrong choice of hydraulic oil.	Use of non-compliant hydraulic oil. Danger of ejection of fluids, overheating.	Information in the manual. Table of oils.
Incorrect assembly/fitting of the hydraulic circuit.	Incorrect assembly or fitting of the hydraulic circuit may damage the hydraulic motor and therefore the motor.	Instruction manual: hydraulic system provided for and warnings.
Extreme temperatures.	Use of the winch at temperatures other than those it was designed for, with the risk of breakage of the mechanical parts and ejection of fluids.	Instruction manual: limits within which the winch is designed for use.
Emission of dangerous materials and substances.	During maintenance, topping up, etc. of the lubricating oil, operators may come into contact with the dangerous substance.	Instruction manual: use of gloves (IPD) provided for.
Failure to comply with maintenance and cleaning procedures.	Failure to switch off the machine before carrying out any operations on it; disassembly of the springs of the negative break -> projection of objects.	Instruction manual: the installer must ensure that the procedures are carried out, making the necessary additions to the instruction manual of the final machine. The negative brake must not be disassembled.

DANGER

Risk of breakage due to lifting of constrained loads or damaging.

Lifting constrained objects on the ground can cause to leave suddenly the load or to reach high stresses with breaking hazard of winch and damage to things or people. It is forbidden to lift or hook blocked or constrained loads.

LIST OF RESIDUAL RISKS AND LIST OF RULES REGARDING WINCHES

8.1.2 RULES

Below are the rules and the information that must be reported in the instruction manual and supplied to the various operators.

Description of rule	Person involved
The controls must comply with the provisions set out at point 1.2 of annex I of the Machine Directive 2006/42/CE	Installer
The safety devices (maximum load exceeded, minimum number of windings, maximum number of windings) must be correctly installed by the installer and must be of the right category for the type of application. The manufacturer cannot define what the winch is to be used for; therefore, the choice and class of safety devices is up to the installer. Refer to the EN 954/1 or EN ISO 13849/1 standards.	Installer
When choosing control devices, pay particular attention to interference with electromagnetic fields (radio controls, etc.)	Installer
If there is an electric motor instead of a hydraulic motor (replacement of hydraulic motor with electric motor), the installer must provide for a load blocking system using a negative brake.	Installer
The installer must provide for a movement control system, especially for controlling drift.	Installer
The installer must provide additional information regarding potential incorrect use.	Installer
Use of IPDs	Installer

LIST OF RESIDUAL RISKS AND LIST OF RULES REGARDING WINCHES

8.2 RECOVERY WINCHES

8.2.1 RESIDUAL RISKS

Risk	Description of the dangerous situation	Solutions adopted
Exceeding the maximum load, breakage and overturning	The machine is not equipped with a maximum load limit because said limit very much depends on the type of application used. When installing the maximum load device, the installer must take account of the conditions in which the winch is expected to be used. In addition, a safety system must be set in place in order to ensure the vehicle the winch is installed on cannot be overturned. All the tests requested (maximum load, overturning) must also be carried out.	Information in the manual.
Loss of stability.	The machine must be properly fixed by the installer.	Information in the manual.
Danger of crushing during transport operations.	During transport, lifting and handling, the machine may fall. In addition, check that the packaging is in good condition and provided with a strap.	Instruction manual; training to be provided to operators in charge of transport, lifting and handling. The operations must be carried out at low speed, ensuring loads are balanced. Also check that the strap is present.
Wrong choice of rope. Rope blocked incorrectly.	The rope must be chosen in accordance with the loads and class of the winch, and must be fixed correctly, otherwise the load will be lost.	Information in the manual.
Risk due to moving parts. Guards not installed or installed incorrectly	The operator may come into contact with moving parts.	Information in the manual regarding the compulsory installation of protective casing by the installer (where necessary).
Moving parts of the drive.	Incorrect assembly of moving parts, causing the risk of breakage or malfunctioning of the machine.	Information in the maintenance instruction manual. Internal assembly diagrams.
Wrong choice of hydraulic oil.	Use of non-compliant hydraulic oil. Danger of ejection of fluids, overheating.	Information in the instruction manual. Table of oils.
Incorrect assembly/fitting of the hydraulic circuit.	Incorrect assembly or fitting of the hydraulic circuit may damage the hydraulic motor and therefore the motor.	Instruction manual: hydraulic system provided for and warnings.
Extreme temperatures.	Use of the winch at temperatures other than those it was designed for, with the risk of breakage of the mechanical parts and ejection of fluids.	Instruction manual: limits within which the winch is designed for use.
Emission of dangerous materials and substances.	During maintenance, topping up, etc. of the lubricating oil, operators may come into contact with the dangerous substance.	Instruction manual: use of gloves (IPD) provided for.
Failure to comply with maintenance and cleaning procedures	Failure to switch off the machine before carrying out any operations on it; Disassembly of the springs of the negative brake -> projection of objects.	Instruction manual: the installer must see to it that the procedures are carried out, making the necessary additions to the instruction manual of the final machine. The negative brake must not be disassembled.
Wrong choice of point of attachment of the load pulled.	The operator must choose a point that is able to withstand the load and that will not cave in suddenly. The hooks positioned on the vehicles are generally used. If such hooks are not available (for example because they are damaged), a different point able to cope with the load must be chosen.	Instruction manual. Usage instructions.

LIST OF RESIDUAL RISKS AND LIST OF RULES REGARDING WINCHES

8.2.2 RULES

Below are the rules and the information that must be reported in the instruction manual and supplied to the various operators.

Description of rule	Person involved
The controls must comply with the provisions set out at point 1.2 of annex I of the Machine Directive 2006/42/CE	Installer
The safety devices (maximum load exceeded, minimum number of threads, maximum number of threads) must be correctly chosen by the installer and must be of the right category for the type of application. The manufacturer cannot define what the winch is to be used for; therefore, the choice and class of safety devices is up to the installer. Refer to the EN 954/1 or EN ISO 13849/1 standards.	Installer
When choosing control devices, pay particular attention to interference with electromagnetic fields (radio controls, etc.)	Installer
If there is an electric motor instead of a hydraulic motor (replacement of hydraulic motor with electric motor), the installer must provide for a load blocking system using a negative brake. N.B.: the FTC refers to hydraulic winches.	Installer
The installer must provide for a movement control system, especially for controlling drift.	Installer
The installer must provide additional information regarding potential incorrect use.	Installer
The installer must provide users with information regarding the safety distances, and must prevent persons from remaining in the immediate surroundings of the rope and behind the load pulled.	Installer
The installer must place the sticker provided with the winch on the release of the drum.	Installer
Use of IPDs	Installer

9 LIFTING AND RECOVERY WINCH ACCESSORIES

9.1 LIFTING

The following accessories are available for correct winch operation:

- Ropes and Hooks
- Special Paints, on request
- Pressure roller systems
- Pressure roller systems with control of minimum and maximum capacity of the rope wound onto the drum, with electric or oil pressure signal reading
- Direct or indirect reading systems for the number of drum revs
- Only with installer support: the option of systems for the reading of winch overload
- Installation of motor-driven systems other than hydraulic liquid systems, where possible

WARNING

The adjustment and calibration of systems for controlling the minimum and maximum capacity of the rope wound onto the drum must be carried out by the installer before the winch start up. The above also applies to any other systems aiming to control winch overload and produced in co-operation with the final installer.

9.2 RECOVERY

The following accessories are available for correct operation of the recovery winch:

- Pneumatic disengage
- Pressure roller systems
- Ropes and Hooks
- Pulley Blocks
- Different systems for drum blocking or releasing
- Special Paints, on request
- Special Rope Guiding System, where possible
- Installation of motor-driven systems other than hydraulic systems, where possible
- Hydraulically-controlled valves for controlling the load and release of the negative lamellar brake

NOTE:

Winches for recovery are supplied with manual drum release, unless specified otherwise.

10 APPENDIX A - ROPES - PULLEYS AND DRUMS

10.1 USE AND MAINTENANCE OF ROPES

10.1.1 MAIN FEATURES

Rope is a complex piece of equipment and deciding which format to use is the result of a compromise between various factors that could affect its life. Steel rope is a composite material and can include a number of different materials, depending on its type:

- a** - its core can be made in the same quality of carbon steel used for the outer strands or in natural or synthetic fibre.
- b** - the lubricant
- c** - coatings or fillings for improving protection against external agents when applicable.

NOTE:

On hoisting and recovery winches the use of synthetic rope is not allowed.

10.1.2 PROCEDURES PRIOR TO USE

It is always good practice to inspect the rope and the documents relating to it before use because its description and/or designation will enable you to identify the parts it is made of. This is also important for storage purposes, which must be in a well-ventilated, dry and enclosed area, which is off the ground, so that routine inspection and handling are possible in order to improve the effect of the lubricant.

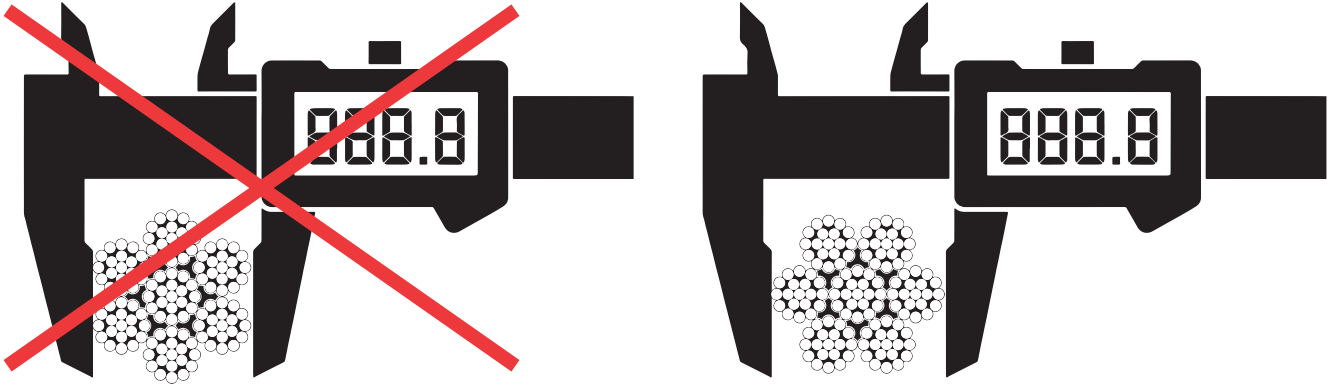

NOTE:

Use PFEIFER caliper.

10.1.3 MEASURING THE ROPE DIAMETER

Rope diameter is the diameter of the circle circumscribing the rope section. You should consider the rope's diameter to be the same as the circle circumscribed around the section, taking care to measure the distance between the outer edge of a strand and the one diametrically opposite when taking the measurement.

10.1.4 HOW TO HANDLE THE ROPE

Before fitting new rope you should control the conditions and dimensions of the machine parts connected to the rope, such as drums, pulleys and rope guides, etc. in order to verify that they are still within the operating limits provided for by the manufacturer of the machine, if they have been used previously. It is always good practice to verify that all pulley blocks and rope guide pulleys are not blocked.

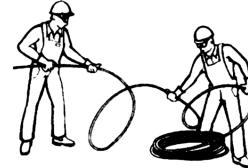

CORRECT

INCORRECT

For handling and fitting the rope, we should distinguish between two different types of supply formats:

- 1 - Coiled rope: the coil of rope should be placed on the ground and uncoiled in a straight line, so that it does not become twisted or knotted, taking steps to prevent it from getting dirty due to dust, sand, damp material or other harmful substances (the appropriate revolving supports can be used for large coils).
- 2 - Rope wound onto a reel: insert a suitably strong shaft inside the reel and then place it on a stand which allows it to turn and be stopped at the same, in order to prevent it from gaining too much speed due to momentum during installation so that the coils can be wound onto the drum or winch correctly, especially with multi-layer coils. It is particularly important that the coils in the lower layers of the rope are wound tightly onto the drum surface (apply a pre-load to keep the rope taut during winding). It is important to place the reel of rope so that the angle of deviation is reduced as much as possible during installation (see "10.1.11 Angle of deviation, page 34"). Should a loop (kink) accidentally occur along the rope, it must not be pulled order to prevent permanent distortion and that it does not come across unwelcome obstacles or contact.

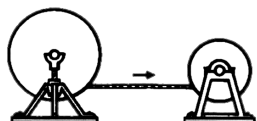
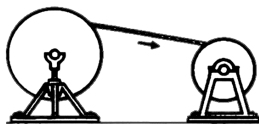
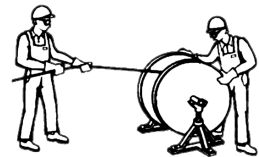





CORRECT

INCORRECT

APPENDIX A - ROPES - PULLEYS AND DRUMS

10.1.5 DIRECTION FOR WINDING THE ROPE

Looking at the direction used for twisting the rope itself, we call it a Z winding when we can see the letter Z when looking at the direction of the threads in the mid section and holding the rope vertically. We call it an S winding when we can see the letter S, again holding the rope vertically and looking at the direction of the threads in the mid section. This defines the direction of the strand twist in the ropes; we must now define the direction of the outer strand wires.



Regular		Lang	
Right	Left	Right	Left
Z/s	S/z	Z/z	S/s
			



There are four possible cases:

- Z/s right regular lay rope (strands Z and wires s)
- S/z left regular lay rope (strands S and wires z)
- Z/z right lang lay rope (strands Z and wires z)
- S/s left lang lay rope (strands S and wires s)

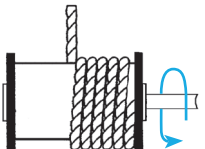
10.1.6 ROPE SELECTION

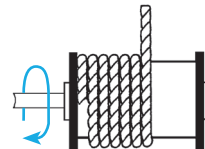
Once you verify that the primary factor determining deterioration is abrasion (wear caused by repeated and ongoing contact with another element, such as drum, pulleys, etc.), your choice should be directed towards a rope whose outer wires are as large as possible. We recommend lang lay rope (with both heads blocked so as to be impossible to turn) and ropes with compacted strands for high levels of abrasion. Flattening is another problem/malfunction which may occur for various reasons but most frequently when the rope is subject to multilayer winding on the drum. Additionally, greater pressure is found between the rope and a smooth or flat surface compared to a grooved drum. When winding with several layers, ropes and strands with textile core should not be used for lifting. Ropes with steel core and compacted strands offer greater resistance against crushing and deformation. To prevent corrosion, in addition to the use of lubricant, you can also use galvanized wires, outer protection and different materials, such as stainless steel, in special circumstances.

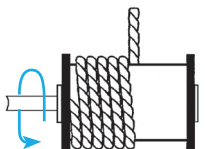
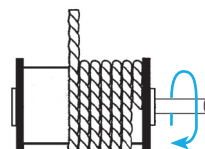
USE RIGHT HAND FOR RIGHT TORQUE ROPE			
Bottom winding		Top winding	
			

Use left hand for left torque rope			
Bottom winding		Top winding	
			

10.1.7 ROPE ANCHORING ONTO THE DRUM AND WINDING DIRECTION

Unless specified otherwise in the instructions provided by the manufacturer of the machine, the position for connecting the rope onto the drum and the winding direction must comply with the illustration above. (see "10.1.6 Rope selection, page 32")

NOTE:

The hand rule can be explained as follows:

- the “thumb” indicates the point and the side for anchoring the rope onto the drum
- the “index finger” indicates the type of rope outlet (top or bottom)
- The right hand indicates the use of right winding rope
- The left hand indicates the use of left winding rope
- The direction of rope winding onto the drum is indicated by a curve starting from the tip of the index finger and has the tip of the thumb as the arrow
- The direction of rope winding onto the drum is always considered as starting at the rope's anchor point. This is also the observation point for drum rotation during winding

This system applies both to smooth drums and grooved drums.

10.1.8 ROPE FITTING AND MAINTAINING

It is essential to check that the rope is wound onto the drum correctly and that there is no looseness in the rope coils or crossing over of layers on the drum, so it is able to gradually adapt to working conditions as the load increases. Ropes must also be inspected thoroughly by trained personnel during the routine and special maintenance of the machinery. In conditions of heavy and continuous use of the machinery, ropes should be checked much more frequently than the scheduled intervals for normal maintenance.

In any case, ISO 4309 shall be taken as a guidance.

With cranes, a check should be carried out at the start of each shift or working day when the crane is in operation, in order to ensure the ropes are placed correctly on their pulleys and on the drums and have not been tampered with. When the crane is working normally, the ropes should be inspected at least once a week to check for any broken wires, kinking or flattening, and any other damage, excess wear and surface corrosion. All rope heads, swivels, safety accessories, pins and pulleys should be checked for damage and worn or seized bushings. Hooks and other couplings for lifting, safety devices and swivels should be checked for damage and that they can move freely and checked for wear. Every bolt hook and the stop nut should be checked for prohibited movement, which could indicate wear and corrosion.

10.1.9 ROPE LUBRICATION

The protection guaranteed by the lubricant used by the rope manufacturer is usually sufficient to prevent deterioration due to corrosion during shipment and storage and for the initial period of rope use. However, for optimum performance, the majority of ropes will benefit from the application of a service lubricant.

The recommended type depends on the application of the rope and the conditions the rope is exposed to.

The service lubricant must be compatible with the original one used by the manufacturer and the methods of application vary from brush lubricators to drip-feed lubricators, high- or low-pressure sprays. It is always advisable to use lubricants suitable for neutral rope as well as for the type and place of use.

10.1.10 BLOCKS STABILITY DURING ROTATION

In order to limit the risks associated with load rotation during lifting and to safeguard the safety of personnel in the relative area, you should always use anti – swivel rope which will, however, give a minimum amount of turning when subjected to a load. If rotation resistant ropes are used, whose ring of outer strands is twisted in the opposite direction to that of the strands layer underneath, the amount of twist produced when loaded, either with both heads blocked (twisting moment) or when one head is free to rotate, is considerably less than with rope with a single layer of threads.

10.1.11 ANGLE OF DEVIATION

The angle of deviation is the angle formed by the axis of the rope and the surface passing through the race of the pulley. The pulley must be directed so as to minimize the entry angle as far as possible, ranging from zero when the rope is midway on the drum to maximum when it is close to one of the two flanges.

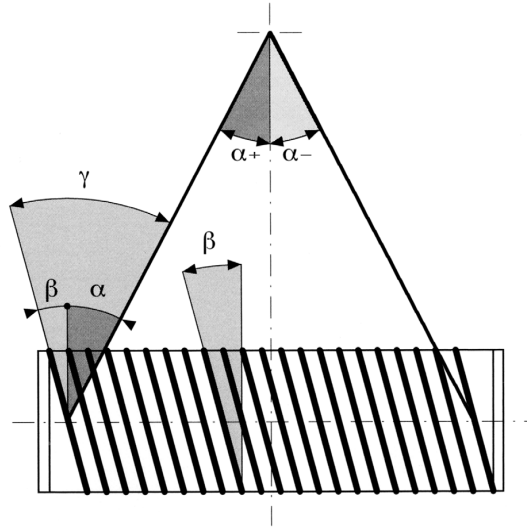

The figure shows a large helical grooved drum whose pitch has angle β and race (pulley) bending. When the rope unwinds starting from the drum towards the pulley, it forms the angle of deviation α . On the drum, the rope will be subject to bending equal to angle γ .

$$\gamma = \alpha + \beta$$

α = maximum angle of deviation on the first pulley

β = groove angle

γ = worst case total angle

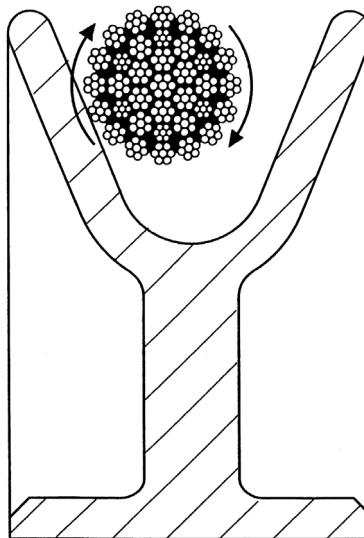

Every time there is an angle of deviation, as the rope enters the pulley, it will initially come into contact with the pulley's flanges. As the rope continues to move from the pulley, it moves away from the flange until it reaches the pulley's race bottom. During this movement, the rope rolls and slips at the same time. As a result of the roll, the rope will turn on its own axis causing a twist which can be generated on the rope or outside of it, both by shortening and lengthening the winding pitch, resulting in inferior fatigue performance and, in the worst case, in a structural damage to the rope which takes on a bird cage shape. As the angle of deviation increases, so does the induced rotation.

APPENDIX A - ROPES - PULLEYS AND DRUMS

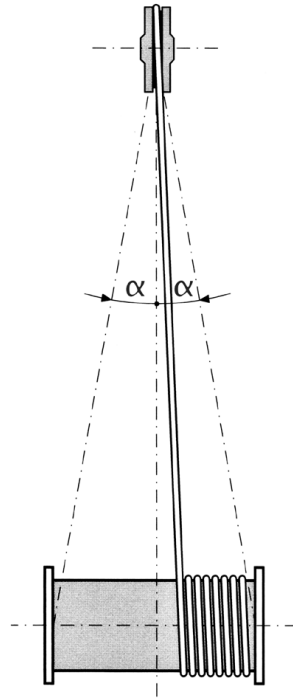

When the rope is wound onto drums without grooves or in several layers, the angle of deviation " α " must not exceed $1^{\circ}30'$ in order to prevent irregular winding of the rope onto the drum. If the angle exceeds this, a rope guide should be used. When the rope is wound onto a grooved drum, the angle of deviation γ should never exceed 4° .

NOTE:

For practical reasons, the construction drawings of some cranes and hoists may not be able to comply with these instructions (recommended values). In this case, the life of the rope will be affected.

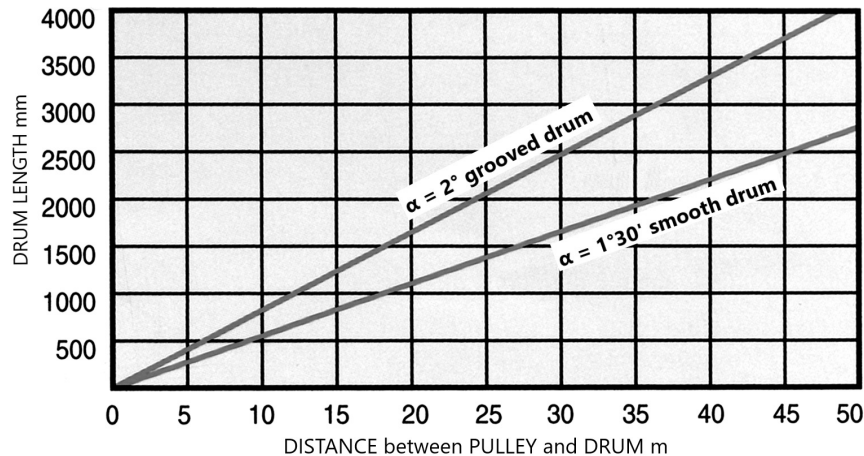

The angles of deviation may be reduced as follows:

- by reducing drum width
- by increasing the distance between the pulley and the drum

Excessive angles of deviation force the rope to be wound onto the drum prematurely, creating vacant spaces between the various coils of rope placed close to the drum flange and therefore increasing the pressure on the rope in crossover positions. Even when the drum has helical grooves, large angles of deviation will inevitably result in local areas of mechanical damage as the wires break (catch) on one another. This phenomenon is usually referred to as "interference" but its extent can be reduced by choosing a "lang lay" rope, if the winding system allows it, or a compacted rope.

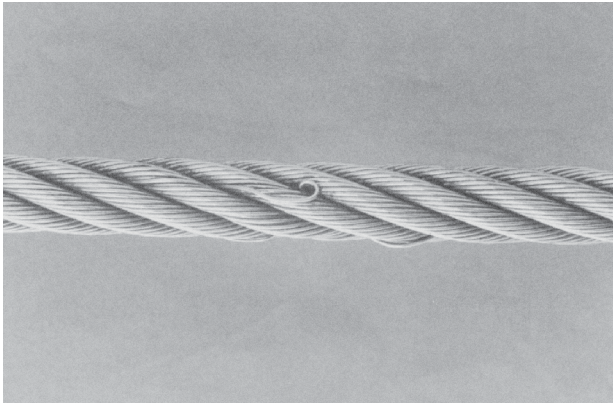

FIGURE 1: Wire protrusion

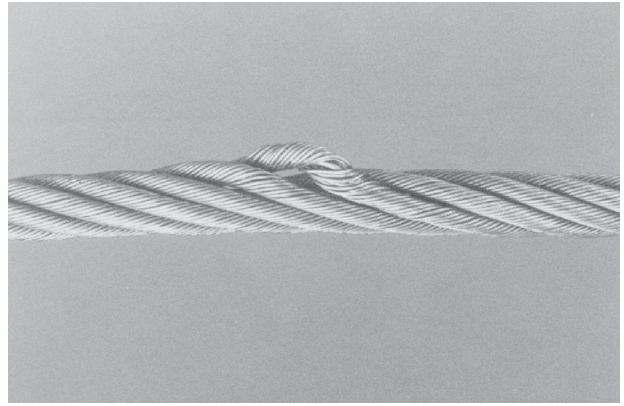

FIGURE 4: Strand protrusion

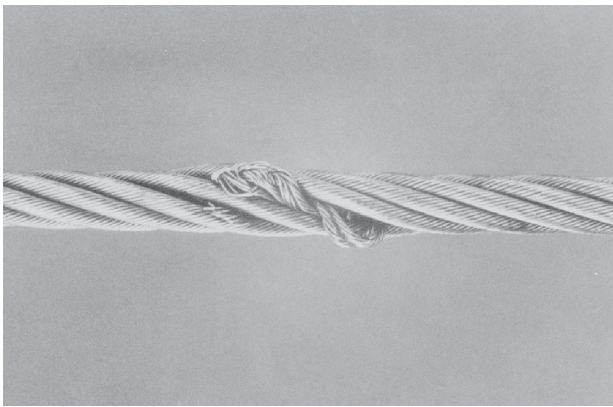

FIGURE 2: Strand protrusion

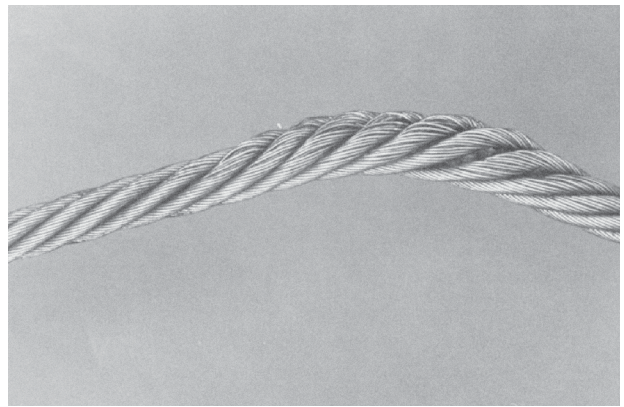

FIGURE 5: Flattened portion

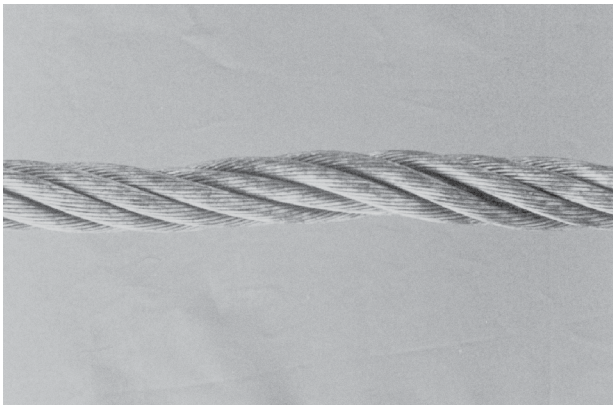

FIGURE 3: Local reduction of rope diameter

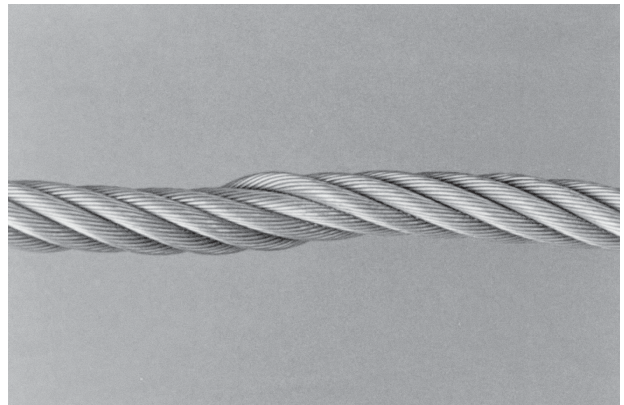

FIGURE 6: Kink

APPENDIX A - ROPES - PULLEYS AND DRUMS

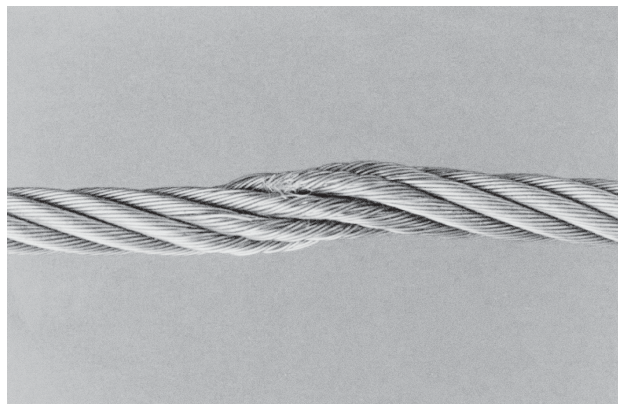

FIGURE 7: Kink

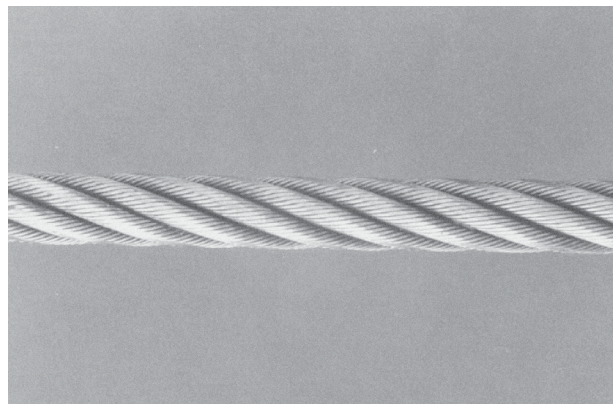

FIGURE 10: External wear

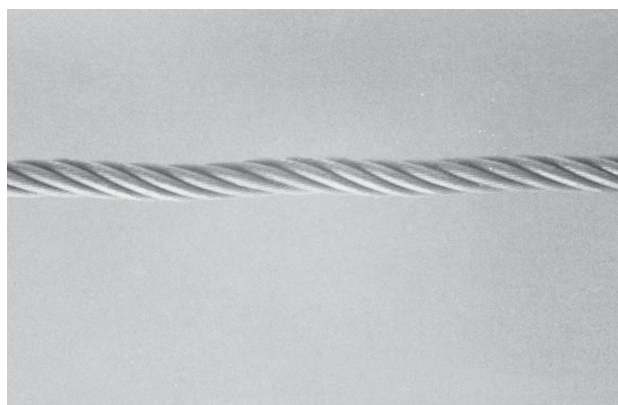

FIGURE 8: Waviness

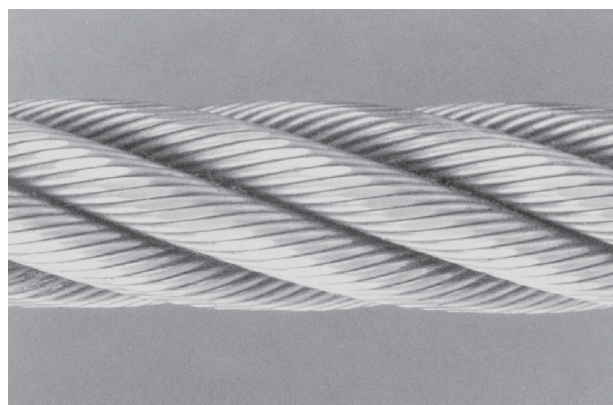

FIGURE 11: Enlargement of Fig. 10

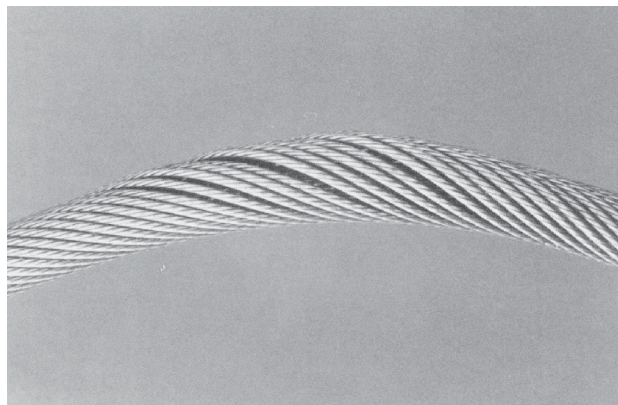

FIGURE 9: Basket deformation

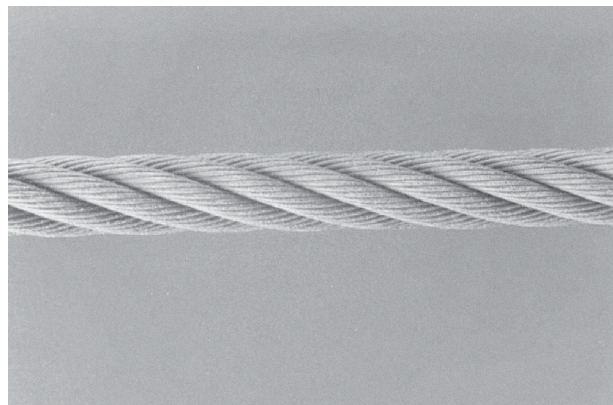

FIGURE 12: External corrosion

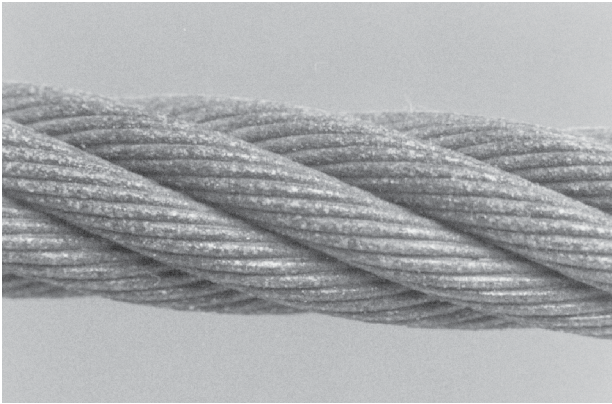

FIGURE 13: Enlargement of fig. 12

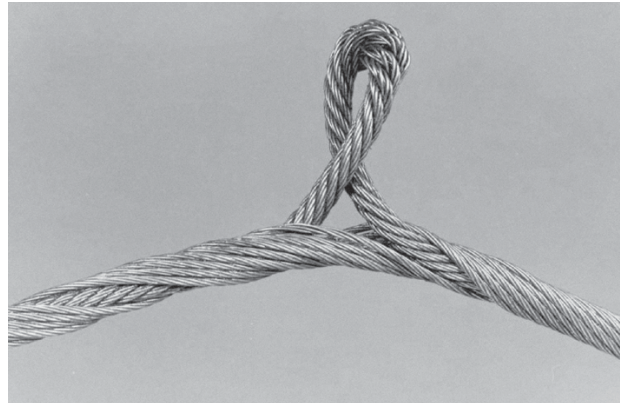

FIGURE 16: Core protrusion

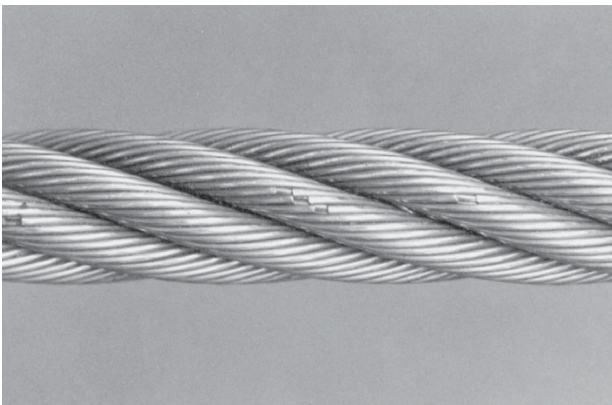

FIGURE 14: Broken wires on the 'crowns' of the strands of the rope

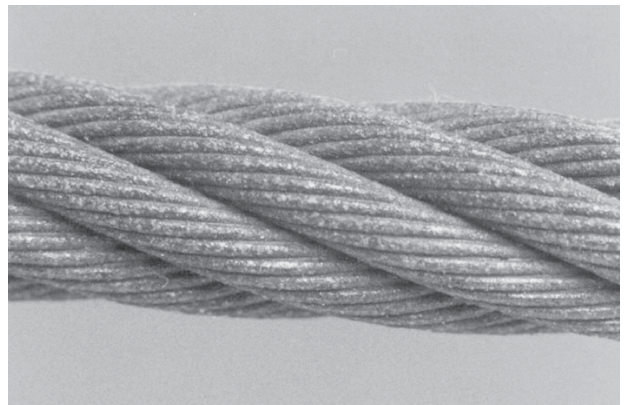

FIGURE 17: Local increase in rope diameter due to core protrusion

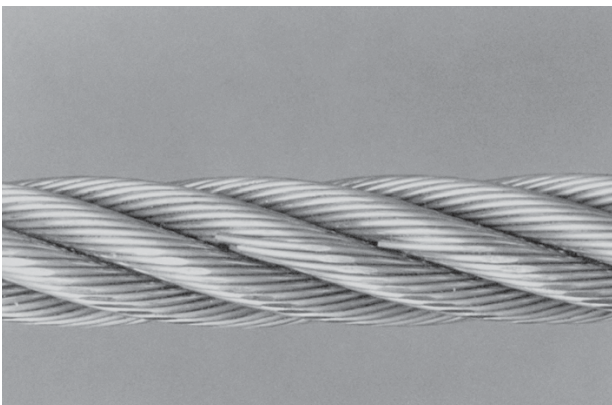

FIGURE 15: Broken wires in the 'valleys' (sometimes called gullets or interstices) between the outer strands of the rope



FIGURE 18: Kink

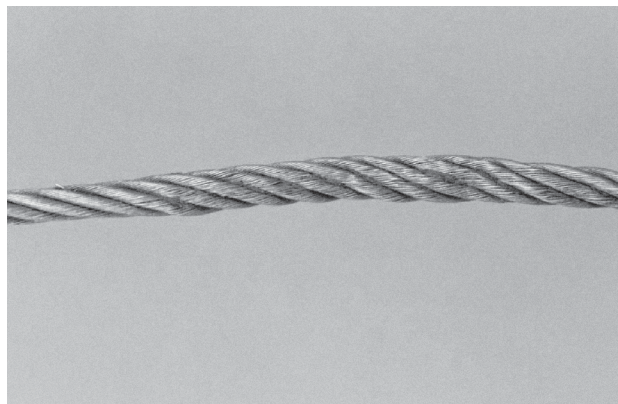

FIGURE 19: Flattened portion

11 APPENDIX B - NOTIONS ON TOWING AND RECOVERY

You can achieve the best results in using winches for recovery if you know a little about the mechanics involved and the difference between the lifting and pulling of a vehicle. Resistance to lifting is very different to resistance to pulling and can be deduced from 4 main factors affecting the recovery of a vehicle:

- 1 - The inherent resistance to movement of the vehicle
- 2 - The total weight of the vehicle
- 3 - The type of surface where the vehicle is to be pulled across
- 4 - The gradient of the surface where the vehicle is to be recovered.
- 5 - The inherent resistance of a vehicle depends on the state of its tyres, surface friction, the weight of the vehicle and its mechanical conditions.

Assuming the vehicle is in good working order, that is to say its tyres are not blocked and are satisfactory (a flat tyre would demand more pulling power), check its status before starting recovery and change any worn parts, if necessary, and then inspect the surrounding area.

- The vehicle weight must include all its fittings and equipment including luggage, fuel, passengers on board, etc.
- The type of surface where the vehicle is to be pulled across is the biggest variable in the recovery equation. The pulling power needed to start moving a vehicle in good condition on a tarmac road will be about 4% of its overall weight, whilst a vehicle that has to be pulled out of deep mud will need the equivalent of 50% of its overall weight in pulling power.

The table below shows different surfaces with their relative proportions of power needed to start moving the vehicle. (type of surface and power required to move the vehicle in proportion to its weight)

TARMAC	best TARMAC road or surface 0.04 of total vehicle weight
GRASS	0.143 of total vehicle weight
DAMP HARD SAND	0.166 of total vehicle weight
GRAVEL	0.2 of total vehicle weight
DAMP SOFT SAND	0.2 of total vehicle weight
DRY SOFT SAND	0.25 of total vehicle weight
SHALLOW MUD	0.33 of total vehicle weight
DEEP MUD	0.5 of total vehicle weight
STICKY CLAY	0.5 of total vehicle weight

NOTE:

Follow the indications provided in the technical documentation for any other coefficients of friction.

A simple formula is shown below for a rough calculation of the power of resistance of a vehicle to be towed on any type of non-sloping surface in the list:

W x S = Power of resistance

W = overall weight

S = coefficient of resistance according to the table

- However, if the surface is not flat, the calculation must take into account the resistance of the slope depending on its gradient. The coefficient for determining resistance based on the slope's gradient, when the distances are short or if the distance is longer but has no bumps or obstacles of any type, is simple.

Usually, each degree of gradient can be said to correspond to a coefficient of 0.017 of the vehicle's weight, up to a maximum of 45° (gradient of 100%); above this, it is considered lifting.

When slopes are involved, this handy formula is added to the previous one, indicating the degrees with G and resulting in:

(W x S) + (G x W x 0.017) = Power of resistance

G= degree of gradient

Should maximum winch recovery capacity be exceeded with direct pulling (considered maximum at the first layer of rope on the drum), you can solve the problem using a pulley block. See " Figure A, page 42".

The same pulley can be used for self-recovery. See " Figure B, page 42". Otherwise it can also be used for direct recovery but with the load creating an angle with the winch axis. See " Figure C, page 42"

WARNING

All the information in this section is purely theoretical and is provided as a users guide for a correct and rational use of winching equipment.

APPENDIX B - NOTIONS ON TOWING AND RECOVERY

Figure A

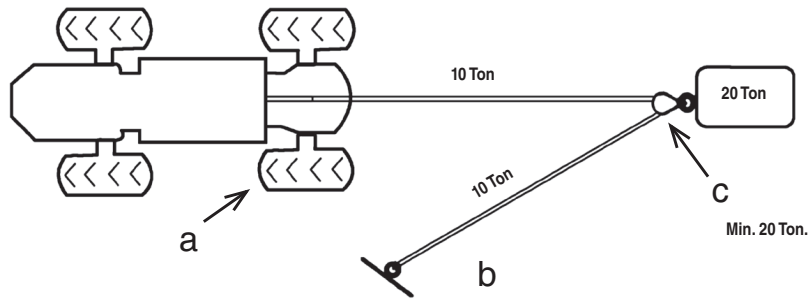

Figure B

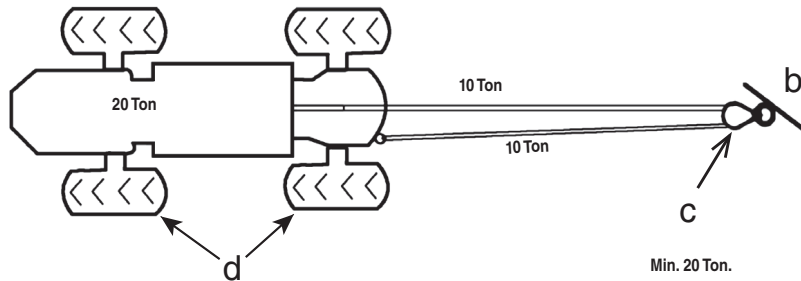
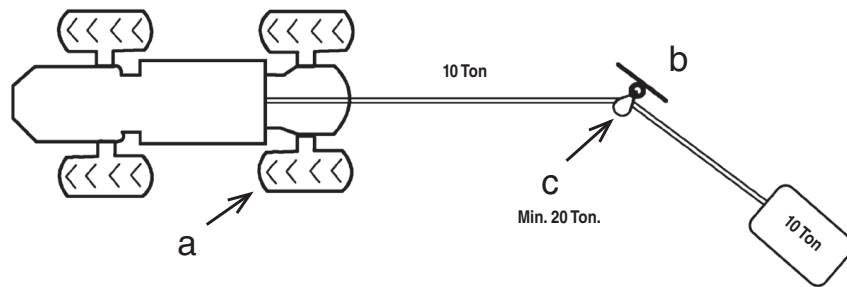

Figure C



- a** - Wheels blocked
- b** - Anchor point
- c** - Pulley block
- d** - Wheels moving

12 CONVERSION TABLES

12.1 BASE UNIT

MEASUREMENT	UNIT	SYMBOLS
Length	Meter	m
Mass	Kilogram	kg
Time	Second	s
Electric Current	Ampere	A
Temperature	Kelvin	K
Luminous Intensity	Candela	cd
Quantity	Mole	mol

12.2 LENGTHS

	INCH	FOOT	YARD	MILLIMETER	METER
1 inch =		0.0833	0.0278	25.4	0.0254
1 foot =	12		0.333	304.8	0.3048
1 yard =	36	3		914.4	0.9144
1 millimetre =	0.03937	0.0033	0.00109		0.001
1 meter =	39.37	3.2808	1.0936	1,000	

12.3 MOMENT

	OUNCE	POUND	POUND	KILOGRAM-METER	METER
1 inch ounce =		0.0625	0.0052	7.2×10^{-4}	7.06×10^{-3}
1 inch pound =	16		0.0833	1.152×10^{-2}	0.1130
1 foot pound =	192	12		0.1383	1.356
1 Kilogram-meter =	1,388.7	86.796	7.233		9.80665
1 Newtonmeter =	141.6	8.850	0.7375	0.1020	

12.4 AREA

	INCH ²	FOOT ²	YARD ²	MM ²	M ²
1 inch ² =		0.0069	0.00077	645.16	6.45×10^{-4}
1 foot ² =	144		0.111	92,903	0.0929
1 yard ² =	1,296	9		836,1	0.8361
1 mm ² =	0.0016	1.0764×10^{-5}	1.196×10^{-6}		43261
1 m ² =	1,55	10764	1196	106	

CONVERSION TABLES

12.5 VOLUME

	INCH ³	US QUART	IMP. GALLON	FOOT ³	US GALLON	LITRE
1 inch ³ =		0,0173	0,0036	0,00058	0,0043	0,0164
1 US quart =	57,75		0,2082	0,0334	0,25	0,9464
1 Imp. gallon =	277	4,8		0,1604	1,2	4,546
1 foot ³ =	1728	29,922	6,23		7,48	28,317
1 US gallon =	231	4	0,8327	0,1337		3,785
1 litro = dm ³	61,024	1,0567	0,22	0,0353	0,264	

12.6 TEMPERATURE

	KELVIN	°C	°F
1 Kelvin =		K - 273.15	K 9/5 - 459.67
1 °C =	°C + 273.15		°C 9/5 + 32
1 °F =	5/9 (°F - 32) + 273.15	(°F - 32) x 5/9	

12.7 DENSITY

	ONCE/INCH ³	POUND/FOOT ³	G/CM ³
1 ounce/inch ³ =		108	1.73
1 pound/foot ³ =	0.0092		0.016
1 g/cm ³ =	0.578	62.43	

12.8 FORCE

	NEWTON (N)	KILOPOUND (KP)	POUNDFORCE
1 newton (N) =		0.10197	0.22481
1 Kilopound (kp) =	9.80665		2.20463
1 poundforce =	4.4482	0.45359	

12.9 MASS

	ONCE	POUND	KG
1 ounce =		0.0625	0.0283
1 pound =	16		0.4536
1 kg =	35.274	2.2046	

12.10 SPEED

	FOOT/S	FOOT/MIN	MILE/HOUR	METER/S.	KM/HOUR
1 foot/s =		60	0.6818	0.3048	1.097
1 foot/min =	0.017		0.0114	0.00508	0.01829
1 mile/hour =	1.4667	88		0.447	1.609
1 meter/s. =	3.280	196.848	2.237		3.6
1 Km/hour =	0.9133	54.68	0.6214	0.278	

12.11 PRESSURE

	INCH HG	PSI	ATMOSPHERE	TORR	MM HG	BAR	MPA	KG/CM ²
1 inch Hg =		0,491	0,0334	25,4	25,4	0,0339	0,00339	0,0345
1 psi =	2,036		0,068	51,715	51,715	0,0689	0,00689	0,0703
1 Atmosphere =	29,921	14,696		760	760	1,0133	0,10133	1,0332
1 torr =	0,0394	0,0193	0,0013		1	0,0013	0,00013	0,00136
1 mm Hg =	0,0394	0,0193	0,0013	1		0,0013	0,00013	0,00136
1 bar =	29,53	14,504	0,987	749,87	749,87		0,1	1,02
1 MPa =	295,3	145,04	9,869	7498,7	7498,7	10		10,2
1 kg/cm ² =	28,95	14,22	0,968	735,35	735,35	0,98	0,098	

© Copyright 2019 Dana Incorporated
All content is subject to copyright by Dana and may not be reproduced in whole or in part by any means, electronic or otherwise, without prior written approval.
THIS INFORMATION IS NOT INTENDED FOR SALE OR RESALE, AND THIS NOTICE MUST REMAIN ON ALL COPIES.

For product inquiries or support,
visit www.dana.com.
For other service publications, visit
www.danaaftermarket.com/literature-library
For online service parts ordering,
visit www.danaaftermarket.com



BREVINI[®]

Motion Systems



1800-OILSOL <https://oilsolutions.com.au/>
1800-645765

sales@oilsolutions.com.au