

Worm Gear 58... for Mounting to AC Motors

Project Planning Manual

DOK-GEAR**-58*WORMGEAR-PRJ1-EN-P

Title	Worm Gear 58... for mounting to AC motors
Type of documentation	Project Planning Manual
Document code	DOK-GEAR**-58*WORMGEAR-PRJ1-EN-P
Internal file reference	<ul style="list-style-type: none"> 9.564.025.4-01
The purpose of this document	<p>This document ...</p> <ul style="list-style-type: none"> assists in the selection of a worm gear 58 ... helps clarify technical data assists in the mechanical integration of the gear into the machine helps specify the order information

Editing sequence

Document designation of previous editions	Status	Comments
9.564.025.4-00	March 91	1st edition
DOK-GEAR**-58*WORMGEAR-PRJ1-EN-P	June 97	MKD, MDD, MHD motors included and layout changed

Copyright © INDRAMAT GmbH, 1991

Copying this document and giving it to others and the use or communication of the contents hereof without express authority, are forbidden. Offenders are liable for the payment of damages. All rights reserved in the event of a patent or the registration of a utility model or design. (DIN 34-1)

Validity All rights are reserved with respect to the content of this documentation and the availability of the product.

Published by INDRAMAT GmbH • Bgm.-Dr.-Nebel-Str. 2 • D-97816 Lohr a. Main
 Telefon 09352/40-0 • Tx 689421 • Fax 09352/40-4885
 Dept. ENA (JL/UW)

Contents

1 Introducing the Product	1-1
2 Dimensioning and Selection	2-1
2.1 Dimensioning	2-1
2.2 Selection	2-2
3 Technical Information	3-1
3.1 Ambient Conditions.....	3-1
3.2 Mechanical Features	3-2
3.3 Power efficiency via speed	3-4
3.4 Possible combinations of worm gear 58... with AC motors	3-4
4 Worm gear 58*3 (Axis Distance 50mm)	4-1
4.1 Technical Data.....	4-1
4.2 Dimensional data 58*3 (Axis distance 50 mm).....	4-2
4.3 Permissible shaft load 58*3 (Axis distance 50 mm)	4-3
4.4 Available Versions	4-4
5 Worm Gear 58*4 (Axis Distance 63mm)	5-1
5.1 Technical Data.....	5-1
5.2 Dimensional data 58*4 (Axis Distance 63 mm)	5-2
5.3 Permissible shaft load 58*4 (Axis Distance 63 mm).....	5-3
5.4 Available Versions	5-4
6 Worm Gear 58*5 (Axis Distance 80mm)	6-1
6.1 Technical Data.....	6-1
6.2 Dimensional data 58*5 (Axis Distance 80 mm)	6-2
6.3 Permissible shaft load 58*5 (Axis Distance 80 mm).....	6-3
6.4 Available Versions	6-4
7 Worm Gear 58*6 (Axis Distance 100mm)	7-1
7.1 Technical Data.....	7-1
7.2 Dimensional data 58*6 (Axis Distance 100 mm)	7-2
7.3 Permissible shaft load 58*6 (Axis Distance 100 mm).....	7-3
7.4 Available Versions	7-4
8 Order Information	8-1
9 Service Notes	9-1

9.1 Contacting Customer Service 9-1
9.2 Fault Report 9-2

1 Introducing the Product

Range of applications Worm gear 58... for mounting to AC motors together with INDRAMAT drive controllers create cost-effective automatization systems for numerous industrial applications.

They are particularly well-suited for use in gear racks or toothed belt drives in handling systems characterized by high speeds and accelerations (e.g., loaders and robotics).

Ratings

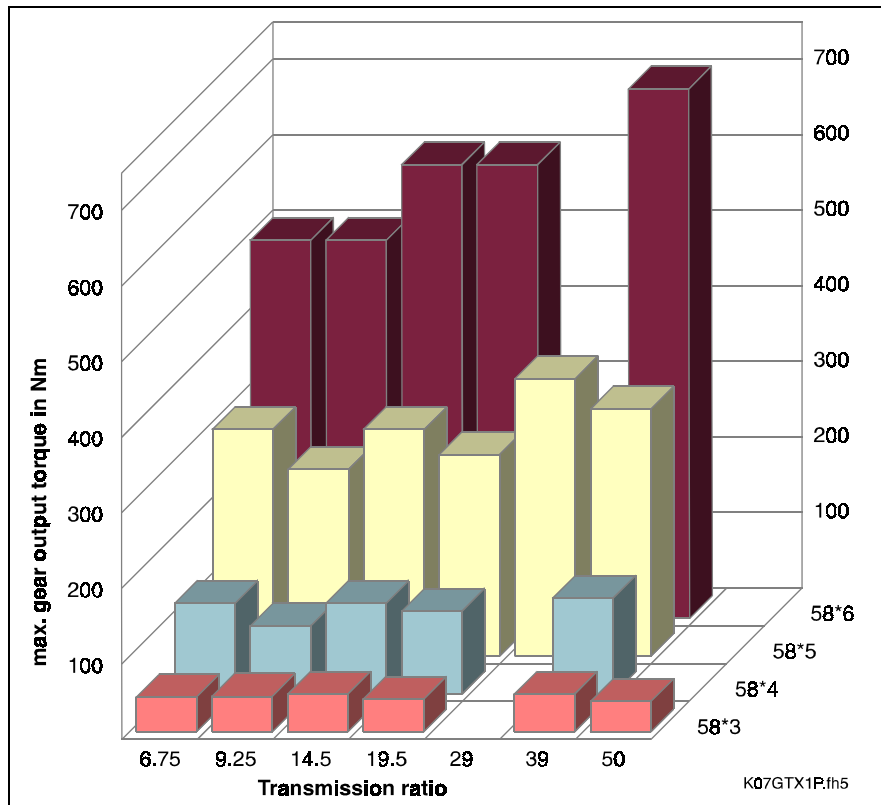

Fig. 1-1: Maximum torque ratings - worm gear 58... for mounting to AC motors

Functional principle Worm gear 58... creates a 90° angle between drive and output shafts. This makes a space-saving and design-friendly construction of handling systems possible. The output shaft of the AC motor is connected by means of a coupling element with the drive pinion of the worm gear. This drive pinion drives the worm wheel, which is made of a special bronze. This makes a high transmission ratio in a gear wheel stage possible.

High operating reliability

- maintenance-free operation resulting from oil lubrication
- can be used even under adverse environmental conditions by means of a completely closed housing with protection category IP 65

High power data

- Low-play gear teeth, which can be adjusted during operations, achieved with the use of ground gear wheel pairs
- low-level noise resulting from worm gear principle
- high dynamics due to low mass to weight ratio
- light weight due to aluminum housing components

- Easy mounting**
- Pinions and belt pulleys directly mounted on the fly because the bearings have been constructed to accommodate high radial loads
 - Mounting of output elements of two different types possible:
 - non-positive shaft-hub connection by means of plain output hollow shaft
 - form-fitting shaft-hub connection through output hollow shaft with keyway
 - The housing design of the gearbox permits mounting to the machine in numerous ways.

2 Dimensioning and Selection

2.1 Dimensioning

Applications which advantageously implement worm gears 58 ... are broken down into the following characteristic velocity-time diagrams:

- triangular velocity paths with pause intervals
- operation at constant speeds and pause intervals
- operation with trapezoidal velocity paths and pause intervals

These characteristic velocity-time diagrams determine layout criteria.

Triangular operation with pause interval

This mode is typical of all highly dynamic infeed motions as common in roll feed mechanisms in the tin, paper, plastic or packaging industries.

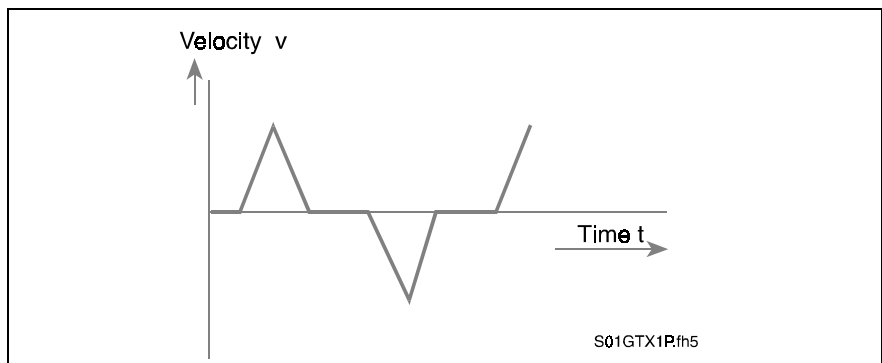

Fig. 2-1: Velocity-time diagram for triangular operations

The layout of this mode is mainly fixed by the required maximum torque M_{max} and the effective torque M_{eff} .

Constant velocity with pause intervals

This mode is typical of all infeed motions as common in winding devices, roll drives, dosing devices in machines for the tin, paper, plastic or packaging industries.

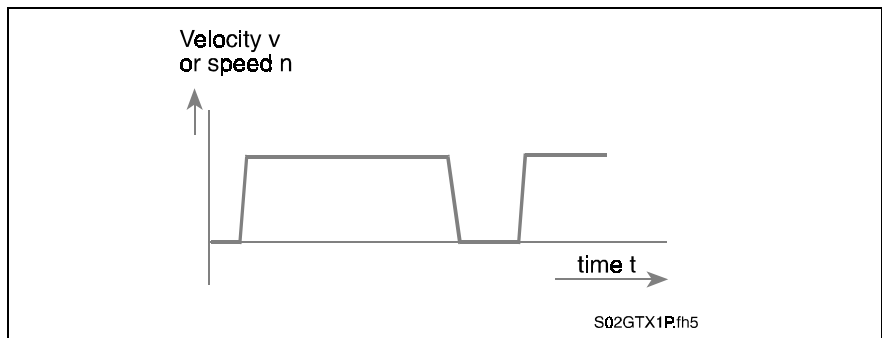

Fig. 2-2: Velocity-time diagram for operation at constant speeds

The layout of this mode is mainly fixed by the required constant torque M_{dN} and the average velocity v_{mittel} or average speed n_{mittel} .

Trapezoidal mode with pause intervals

This mode is typical for most infeed motions but especially for loaders and handling systems as seen in almost all industrial applications.

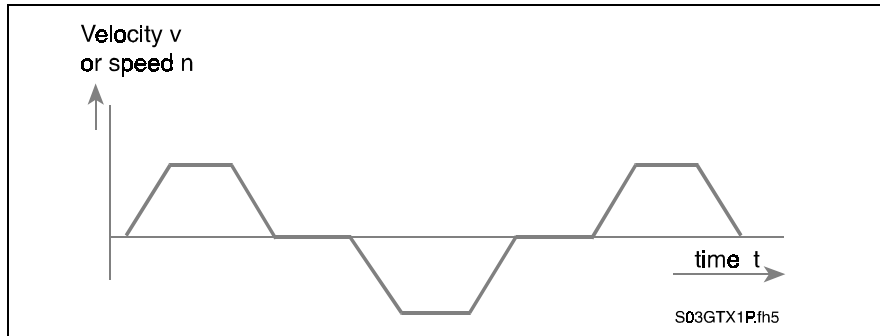

Fig. 2-3: Velocity-time diagram for trapezoidal operations

The layout of this mode is determined primarily by the required maximum torque M_{\max} in the accel phases, the effective torque M_{eff} over the entire cycle time and the average velocity v_{mittel} or average speed n_{mittel} .

2.2 Selection

Drive-determining variables

Selecting the drive, i.e., the suitable motor-gearbox combination, operation with one drive controller means that relevant, drive-determining variables must be determined, namely,

- frictional torque
- weight torque
- processing torque
- acceleration torque
- effective torque
- required speed

Layout criteria

The motor-gearbox combination operated with one drive controller must satisfy the following:

- it must be possible to reach the desired speed
- the continuous torque must exceed effective torque
- intermittent operating torque must exceed the sum of frictional, weight and processing torques
- maximum torque must exceed the sum of frictional, weight and acceleration torques
- the needed runup time must be less than 400 ms

Additionally, note the following about the gearbox:

- **maximum required motor torque must be smaller than the maximum gear input torque**
- **and maximum required motor speed must be smaller than maximum allowable gear-input speed.**

3 Technical Information

3.1 Ambient Conditions

Maximum ambient temperature, maximum installation elevation

The data specified in the selection lists are achieved as follows:

ambient temperature: 0..+45°

installation elevation: 0..1000 meters above sea level

Deviating conditions mean that the data are derated in terms of the diagrams in Fig. 3-1. If both ambient temperature and higher elevations occur simultaneously, then multiply the power data with both factors.

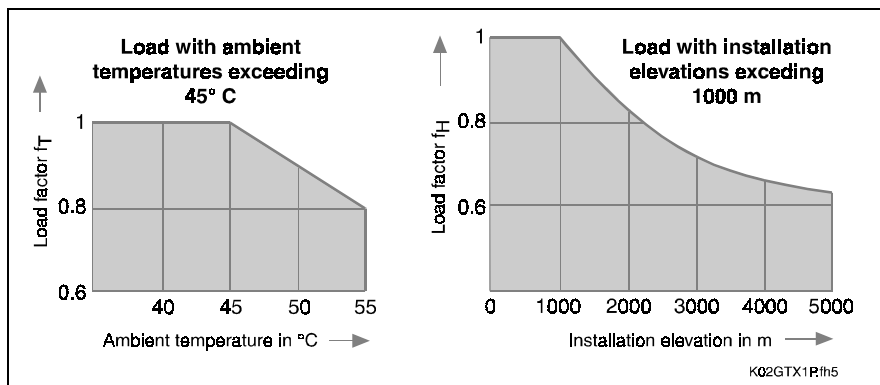

Fig. 3-1: Load capacities for higher ambient temperature and installation elevations

Protection category

As per DIN VDE 0470, section 1 (edition dated 11/92), the AC motor with mounted worm gear 58... is protected by the housing against

- contact with voltage conductive parts or moving parts
- the penetration of extrinsic objects and water.

The protection category is defined in terms of two letters IP (International Protection) and two numbers. The code is IP 65 for AC motors with mounted worm gear 58... .

- for the housing of motor and gear box which are screwed together
- for the output shaft of the gearbox
- for the power and feedback connections of the motor assuming proper mounting.

The first number is protection against contact and penetration of objects. The 6 thus means

- protection against penetration of dust
- complete penetration protection.

The second number is the protection against water. Number 5 means

- protection against a jet of water from a nozzle, coming from all directions against the machine (housing).

Housing coat

The coat is a primary coat. An additional coat with 40µm may be applied.

The primary coat is resistant to

- weathering, yellowing and chalking
- diluted acids and caustic solutions

The primary coat can peel off, however, if frequently steam cleaned.

Operating mode

Worm gears 58...are suited for operating mode S5 (intermittent mode) as per DIN VDE 0530. ON time in this case may not exceed 60%.

$$ED = \frac{T_A + T_B + T_{Br}}{T_s} \cdot 100\%$$

ED: ON time in %
 T_A: warm up time in s
 T_B: processing time in s
 T_{Br}: decel time in s
 T_s: duty cycle time in s

Fig. 3-2: Calculating ON time

The number of cycles may also not exceed 1000 cycles per hour. One cycle is defined as a duration of the traversing process made up of one accel and one decel procedure.

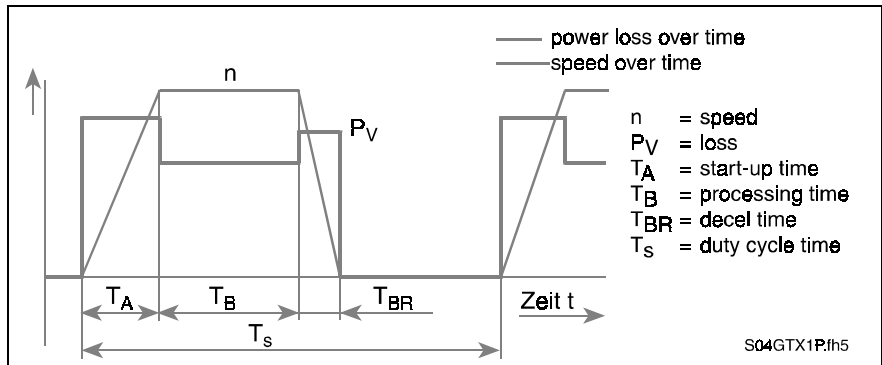

Fig. 3-3: S5 mode (intermittent mode with electronic deceleration)

3.2 Mechanical Features

Construction, orientation

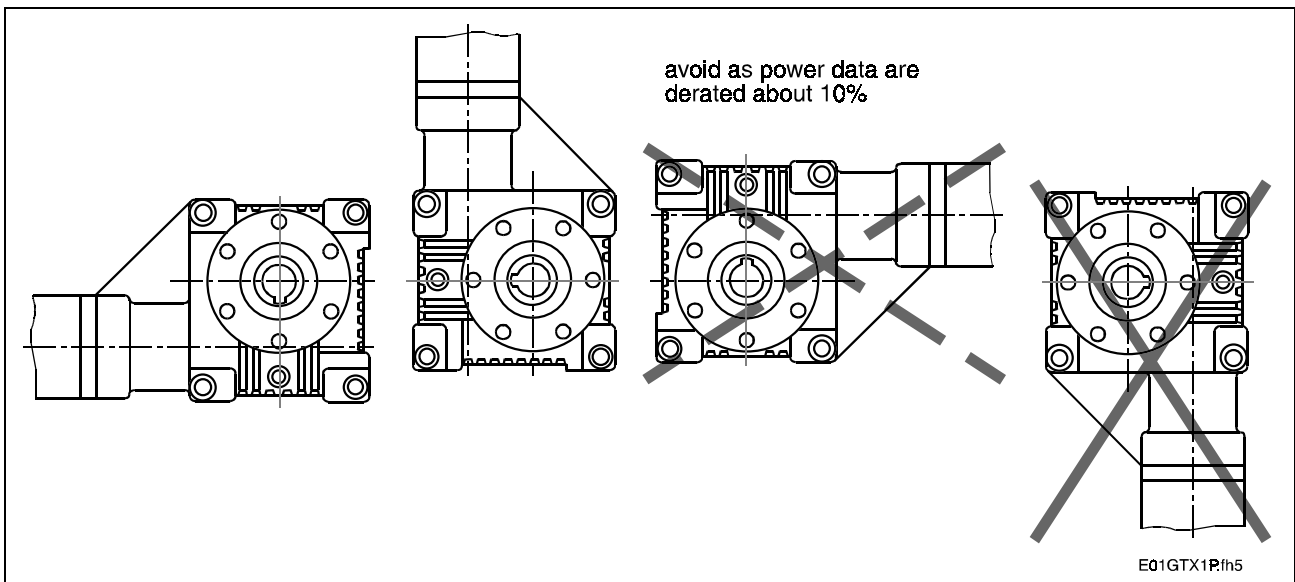

Fig. 3-4: Permissible mounting orientations

Output hollow shaft The output hollow shaft of worm gears 58... is obtainable in the following variations.

- **Plain output hollow shaft (standard)**

For nonpositive shaft-hub connections.

This means higher quiet running and a backlash free connection between shaft and hub.

Note: We recommend the use of an output hollow shaft with non-positive shaft-hub connections.

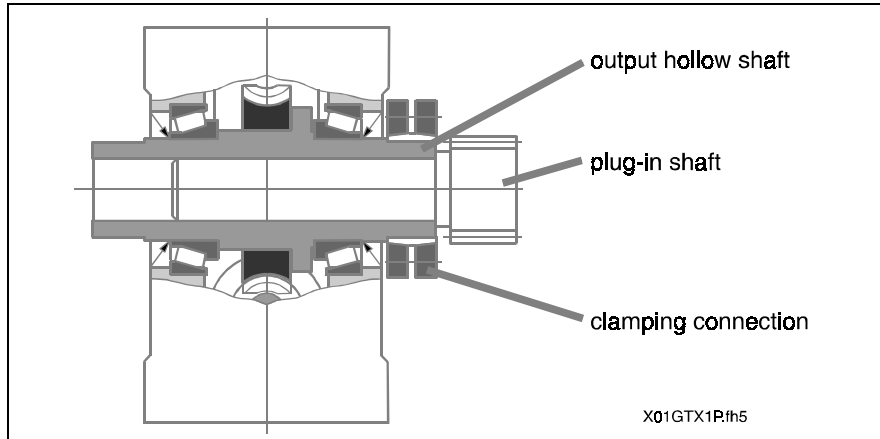

Fig. 3-5: Worm gears with plain output hollow shaft

- **Output hollow shaft with keyway per DIN 6885, sh.1 (ed. 8/68)**

For form-fitting shaft-hub connections.

This type of connection is suited for torques with a constant direction and low requirements. The hub must be additionally axially secured. There is a groove for a retaining ring on the gear output hollow shaft.

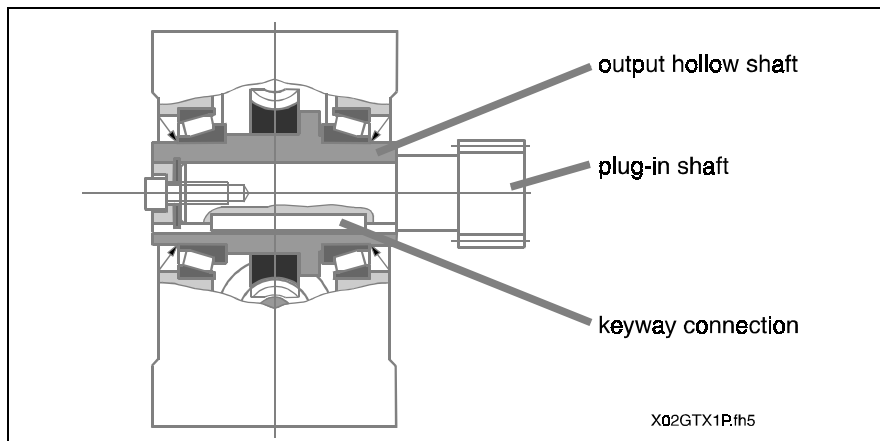

Fig. 3-6: Worm gear with output hollow shaft with keyway

Note: Plug-in shaft with accessories can be obtained from
 ATLANTA Zahnrad- und Werkzeugfabrik
 Eugen Seidenspinner GmbH & Co
 Postfach 11 61
 D-74321 Bietigheim-Bissingen
 Tel. +49/7142/7001-0

These cannot be purchased from INDRAMAT.

Shaft load The axial and radial loads must be individually checked when checking general shaft load. The allowable values are specified in the section „Technical Data“.

3.3 Power efficiency via speed

The power efficiency of worm gears depends on the transmission ratio and gear input speed.

Use the following diagram to estimate relevant power efficiency.

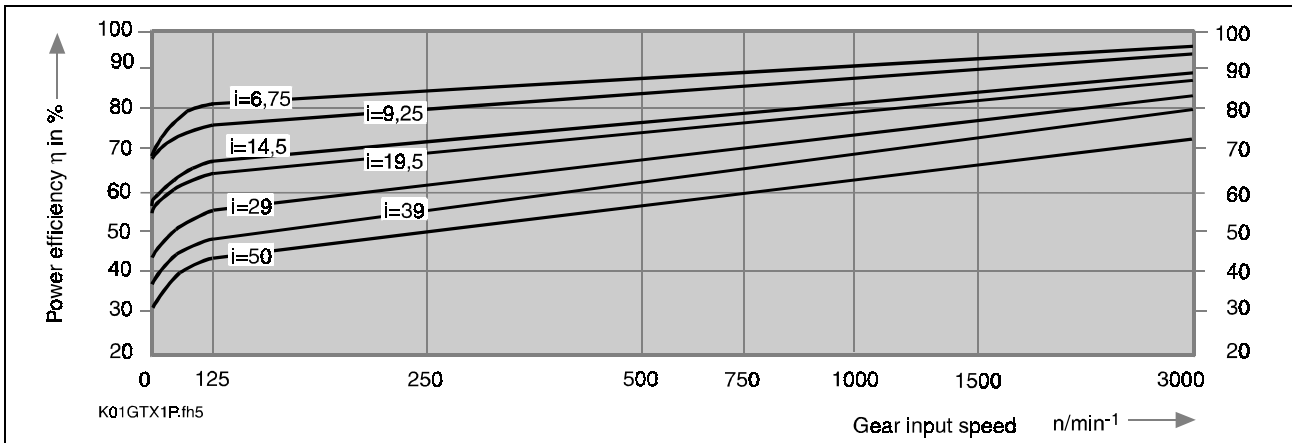

Fig. 3-7: Power efficiency of worm gears via speed

3.4 Possible combinations of worm gear 58... with AC motors

The following table specifies possible combinations.

Gear types	Axis distance mm	Motor type
58*3	50	MAC041, MAC063, MAC071, MDD041, MDD065, MDD071 MKD041, MKD071, MHD041, MHD071
58*4	63	MAC063, MAC071, MAC090 ²⁾ , MAC092, MAC095, MAC114 MDD065, MDD071, MDD 090 ¹⁾²⁾ , MKD071, MKD090, MHD071
58*5	80	MAC090 ²⁾ , MAC093 ²⁾ , MAC095, MAC112, MAC114, MAC117 MDD090 ¹⁾²⁾ , MDD093 ¹⁾²⁾ , MDD112 ¹⁾³⁾ , MKD090, MKD112, MHD112
58*6	100	MAC090 ²⁾ , MAC093 ²⁾ , MAC095, MAC112 ³⁾ , MAC114, MAC115 ³⁾ , MAC117, MDD090 ¹⁾²⁾ , MDD093 ¹⁾²⁾ , MDD112 ¹⁾³⁾ , MDD115 ¹⁾³⁾ MKD090, MKD112, MHD112
¹⁾ Liquid-cooled motors may not be combined. ²⁾ Only with center diameter Ø 110 mm ³⁾ Only with center diameter Ø 130 mm		

Fig. 3-8: Possible combinations of worm gear 58... with AC motors

Note: In order to be able to mount the worm gears to the motors, it is necessary that they have plain output shafts.

4 Worm gear 58*3 (Axis Distance 50mm)

4.1 Technical Data

Transmission-dependent data

Designation	Symbol	Unit	58*3					
Transmission ratio	i	-	6.75	9.25	14.5	19.5	39.0	50.0
Maximum input speed ¹⁾	n _{in}	min ⁻¹	3000	3000	3000	3000	3000	3000
Maximum input torque ²⁾	M _{in,max}	Nm	7.5	5.7	4.2	2.7	1.8	1.8
Maximum output speed	n _{out}	min ⁻¹	444	324	207	154	77	60
Maximum output torque ²⁾	M _{out,max}	Nm	46	47	50	43	50	40
Power efficiency at standstill	η _o	%	69	68	59	57	38	30
Power efficiency n _{in} = 1500 min ⁻¹	η	%	91	89	83	81	70	64
Moment of inertia ³⁾	J	kgcm ²	1.26	1.20	1.13	1.05	1.08	1.06
Torsional stiffness ⁴⁾	D	Nm/rad	52000	52000	52000	52000	52000	52000
¹⁾ Theoretically possible gear-input speed ²⁾ Available for a maximum of 400ms ³⁾ Mass moment of inertia of gear including the coupling unit to the motor as relates to the gear input side ⁴⁾ Torsional stiffness of the gear in terms of the gear output side with fixed gear input side								

Fig. 4-1: Transmission-dependent data

General data

Designation	Symbol	Unit	58*3
torsional play ¹⁾	Δφ	arcmin	≤ 3
service life	L _{10h}	h	30000
lubricant	-		oil
allowable ambient temperature	T _{Um}	°C	0...45
noise level	L _p	dB(A)	<70
protection category	-		IP 65
weight	m	kg	8
mounting to			see section 3.4
¹⁾ relates to gear output side with 2% gear nominal output torque and fixed gear input side			

Fig. 4-2: General data

4.2 Dimensional data 58*3 (Axis distance 50 mm)

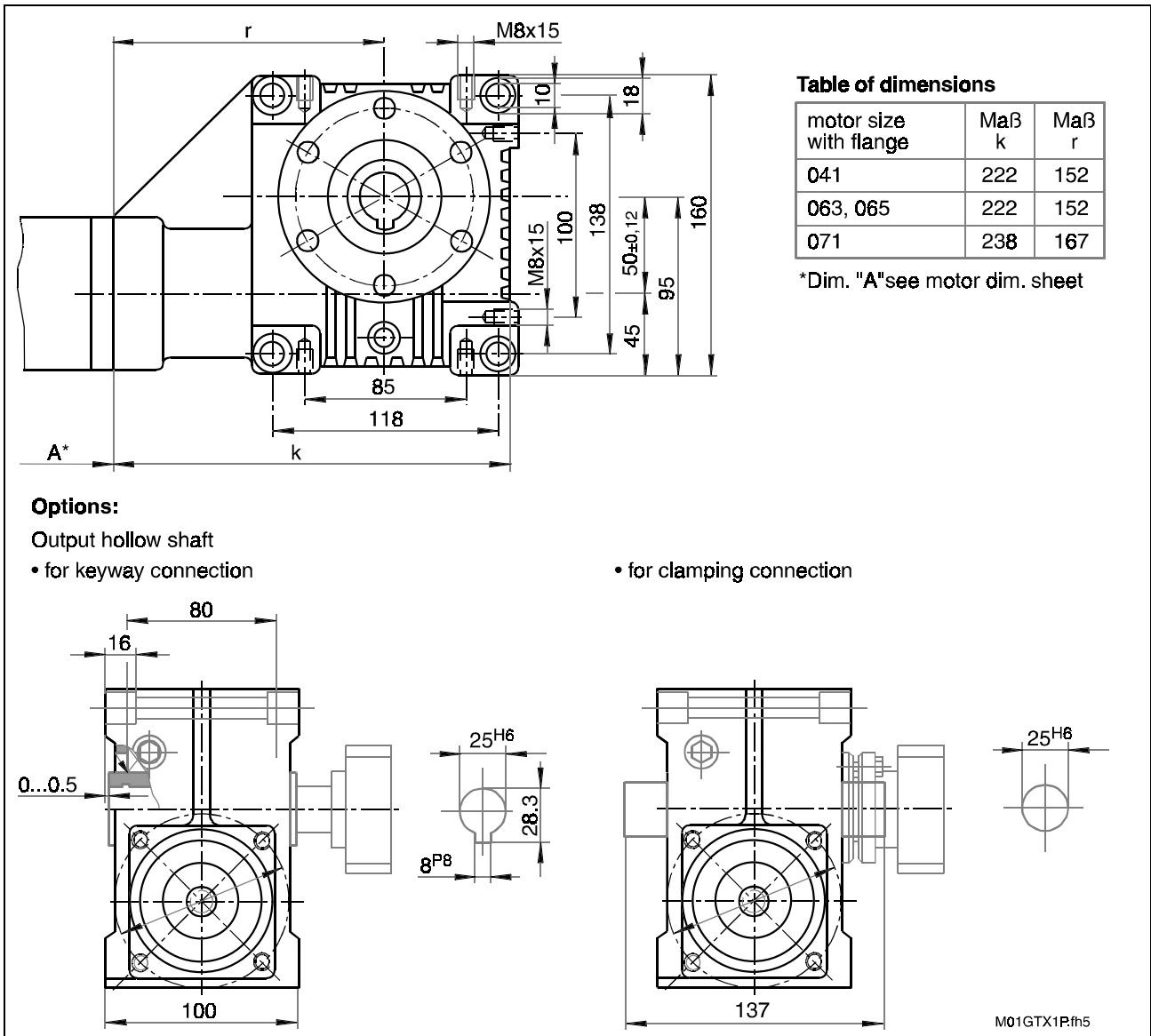

Fig. 4-3: Dimensional data 58*3 (axis distance 50 mm)

4.3 Permissible shaft load 58*3 (Axis distance 50 mm)

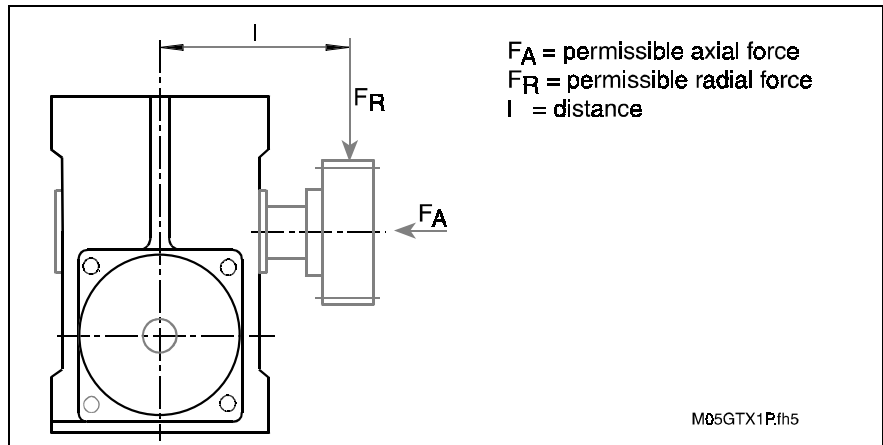

Fig. 4-4: Explanation of the variables influencing permissible shaft load

Permissible radial force

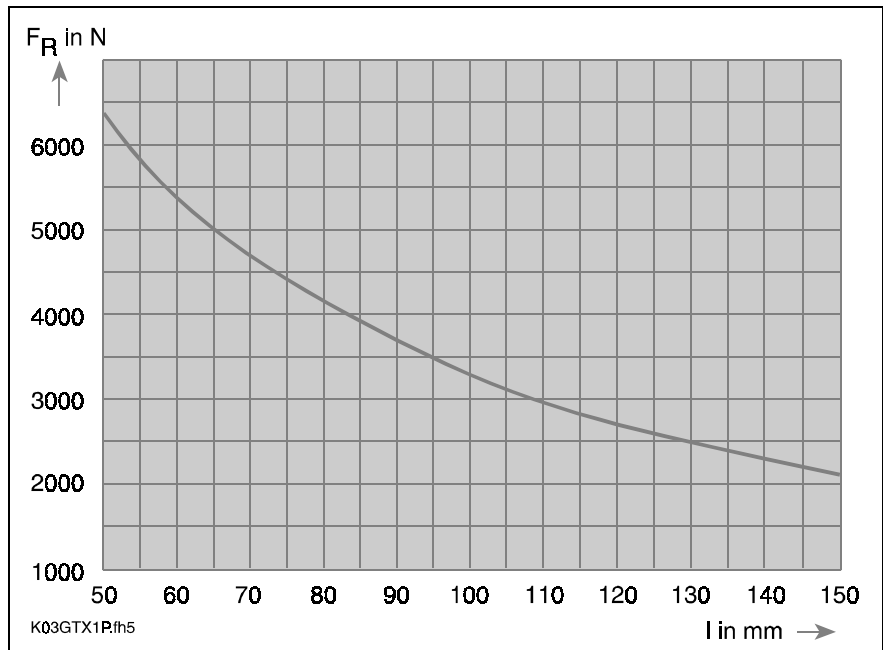

Fig. 4-5: Permissible radial force

Permissible axis force

$F_A = 1800 \text{ N}$

Fig. 4-6: Permissible axis force

4.4 Available Versions

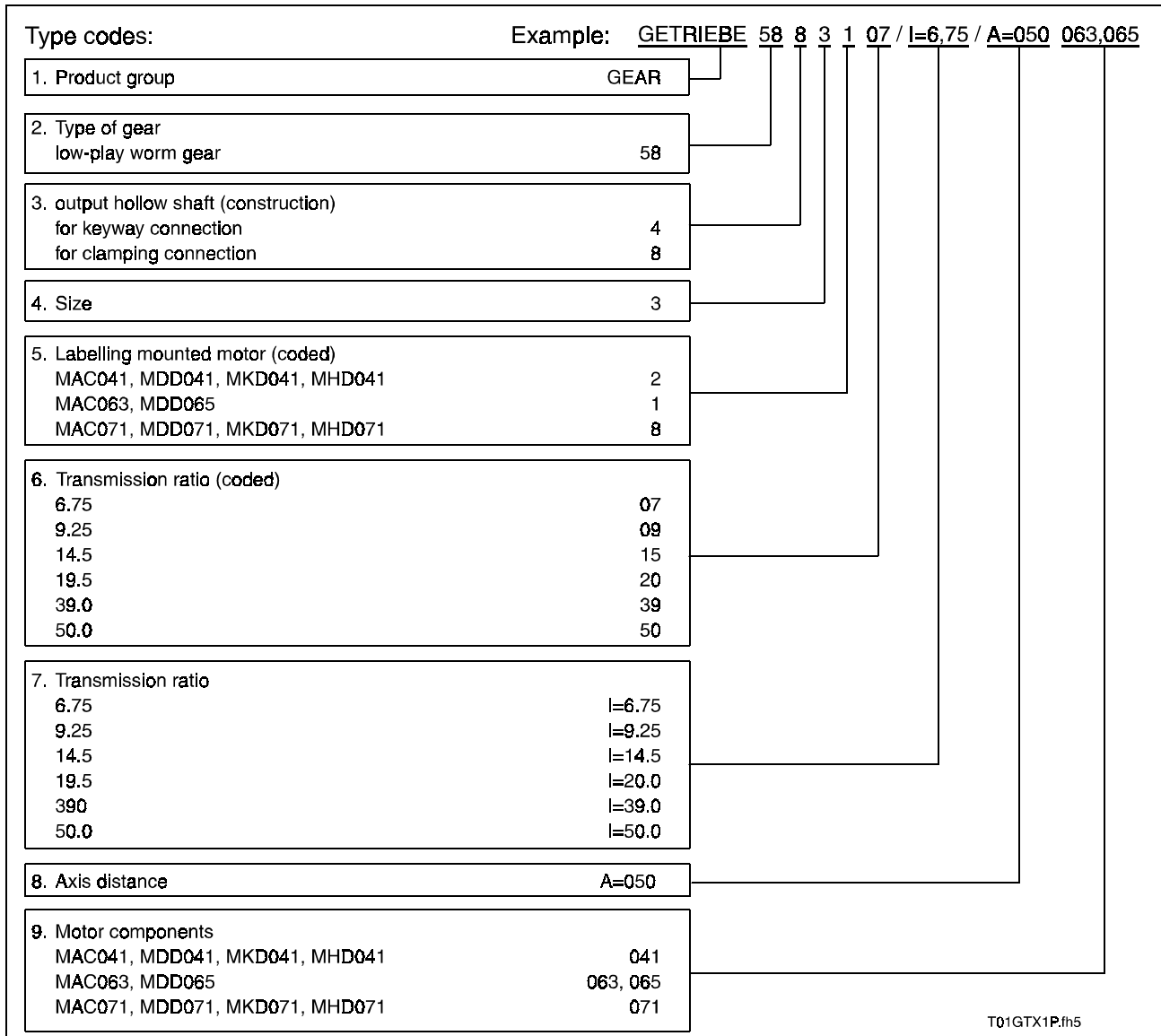

Fig. 4-7: Available versions of 58*3 depicted in terms of type codes

5 Worm Gear 58*4 (Axis Distance 63mm)

5.1 Technical Data

Transmission-Dependent Data

Designation	Symbol	Unit	58*4				
			6.75	9.25	14.5	19.5	39.0
Transmission ratio	i	-	6.75	9.25	14.5	19.5	39.0
Maximum input speed ¹⁾	n _{in}	min ⁻¹	3000	3000	3000	3000	3000
Maximum input torque ²⁾	M _{in,max}	Nm	19.5	10.8	9.9	6.8	4.5
Maximum output speed	n _{out}	min ⁻¹	444	324	207	154	77
Maximum output torque ²⁾	M _{out,max}	Nm	120	90	120	110	127
Power efficiency at standstill	η _o	%	69	68	59	57	38
Power efficiency at n _{in} = 1500 min ⁻¹	η	%	91	90	84	83	73
Moment of inertia ³⁾	J	kgcm ²	4.0	3.61	3.59	3.32	3.64
Torsional stiffness ⁴⁾	D	Nm/rad	115000	115000	115000	115000	115000

¹⁾ Theoretically possible gear input speed
²⁾ Available for a maximum of 400 ms
³⁾ Mass moment of inertia of gear including coupling unit to motor in terms of gear input side
⁴⁾ Torsional stiffness of the gear in terms of gear output side with fixed gear input side

Fig. 5-1: Transmission-Dependent Data

General data

Designation	Symbol	Unit	58*4
Torsional play ¹⁾	Δφ	arcmin	≤ 3
Service life	L _{10h}	h	30000
Lubricant	-		Oil
permissible ambient temperature	T _{Um}	°C	0...45
Noise level	L _p	dB(A)	<70
Protection category	-		IP 65
Weight	m	kg	13
Mounting for			See section 3.4

¹⁾ in terms of gear output side with 2% gear nominal output torque and fixed gear input side

Fig. 5-2: General data

5.2 Dimensional Data 58*4 (Axis Distance 63 mm)

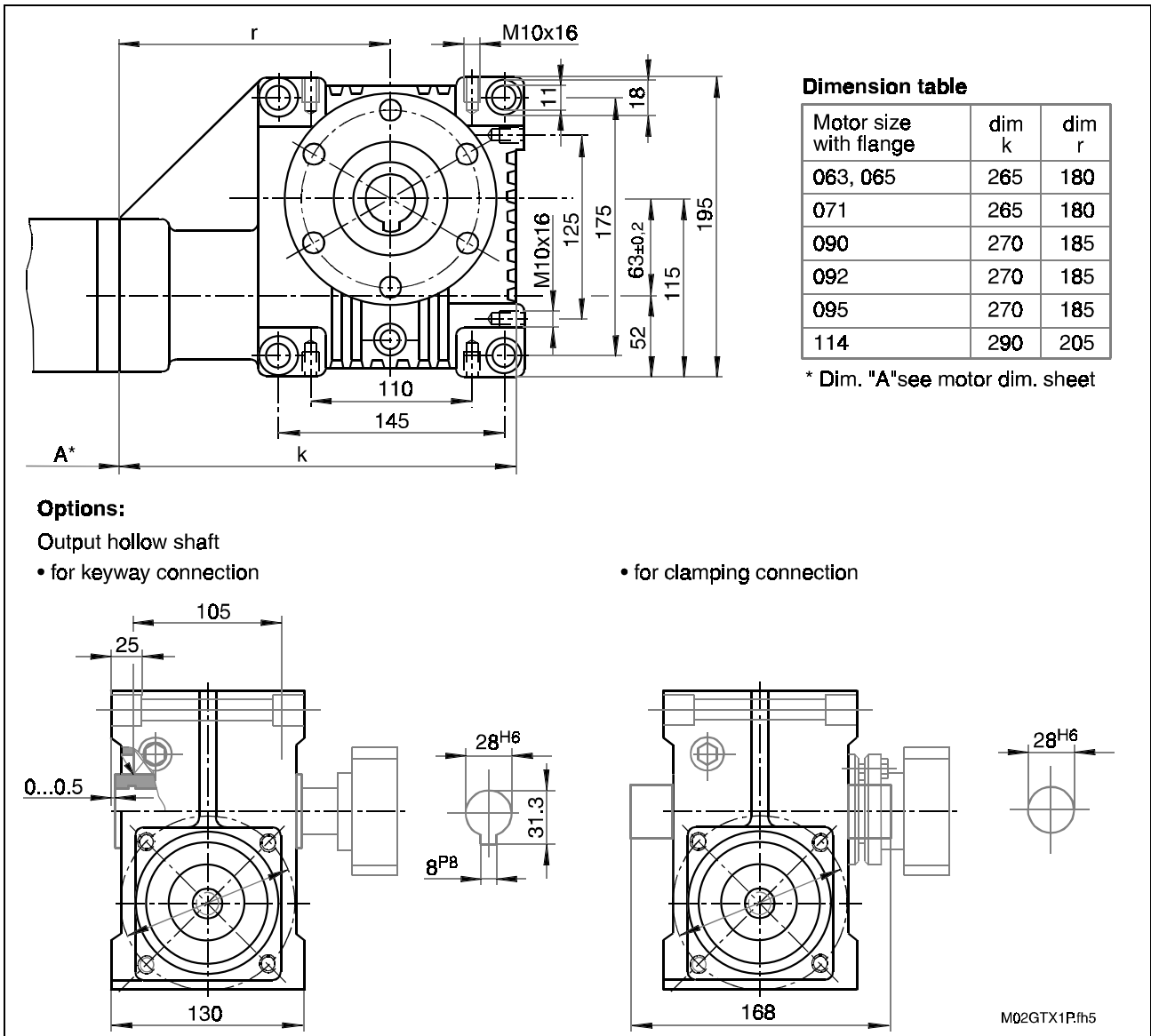

Fig. 5-3: Dimensional data 58*4 (Axis distance 63 mm)

5.3 Permissible shaft load 58*4 (Axis Distance 63 mm)

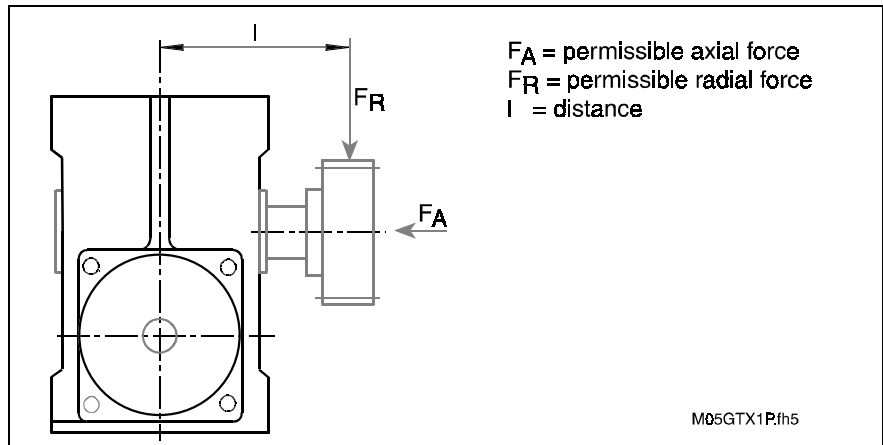

Fig. 5-4: Explanation of the variables influencing permissible shaft load

Permissible radial force

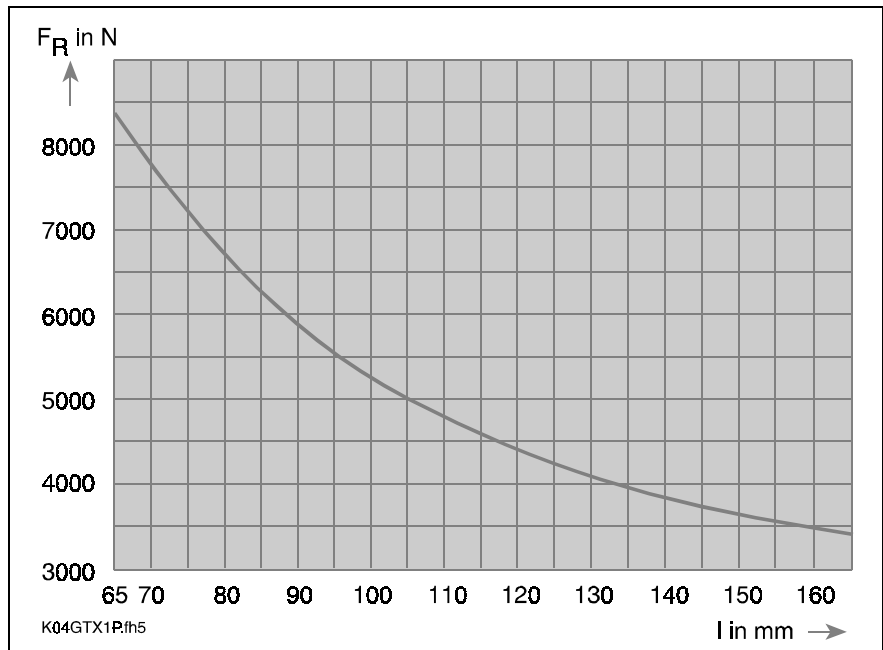

Fig. 5-5: Permissible radial force

Permissible axial force

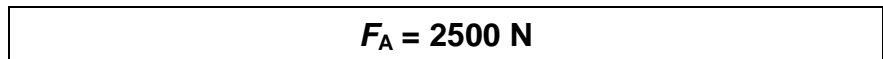

Fig. 5-6: Permissible axial force

5.4 Available Versions

Type codes:	Example: <u>GETRIEBE</u> <u>58</u> <u>8</u> <u>4</u> <u>1</u> <u>07</u> / <u>I=6,75</u> / <u>A=063</u> <u>063,065</u>
1. Product group GEAR	
2. Type of gear low-play worm gear	58
3. Output hollow shaft (constr.) for keyway connection	4
for clamping connection	8
4. Size	4
5. Designating the mounted motor (coded)	
MAC063, MDD065	1
MAC071, MDD071, MKD071, MHD071	3
MAC090 ²⁾ , MAC095, MDD090 ¹⁾²⁾ , MKD090	0
MAC092	4
MAC114	9
6. Transmission ratio (coded)	
6.75	07
9.25	09
14.5	15
19.5	20
39.0	39
7. Transmission ratio	
6.75	I=6.75
9.25	I=9.25
14.5	I=14.5
19.5	I=20.0
39.0	I=39.0
8. Axis distance	A=063
9. Designation the motor	
MAC063, MDD065	063, 065
MAC071, MDD071, MKD071, MHD071	071
MAC090 ²⁾ , MAC095, MDD090 ¹⁾²⁾ , MKD090	090
MAC092	092
MAC114	114

¹⁾ Motors with liquid-cooling cannot be combined.
²⁾ only with centering diameters \varnothing 110 mm

T02GTX1P.fh5

Fig. 5-7: Available versions 58*4 depicted using type codes

6 Worm Gear 58*5 (Axis Distance 80mm)

6.1 Technical Data

Transmission-dependent data

Designation	Symbol	Unit	58*5					
Transmission ratio	i	-	6.75	9.25	14.5	19.5	29.0	39.0
Maximum input speed ¹⁾	n _{in}	min ⁻¹	3000	3000	3000	3000	3000	3000
Maximum input torque ²⁾	M _{in,max}	Nm	48.8	29.7	23.8	15.9	15.8	10.9
Maximum output speed	n _{out}	min ⁻¹	444	324	207	154	103	77
Maximum output torque ²⁾	M _{out,max}	Nm	300	247	300	267	367	327
Power efficiency at standstill	η _o	%	69	68	59	57	43	38
Power efficiency at n _{in} = 1500 min ⁻¹	η	%	91	90	87	86	80	77
Moment of inertia ³⁾	J	kgcm ²	12.0	10.6	11.2	9.8	9.9	10.1
Torsional stiffness ⁴⁾	D	Nm/rad	200000	200000	200000	200000	200000	200000
¹⁾ Theoretically possible gear input speed ²⁾ Available for a maximum of 400 ms ³⁾ Mass moment of inertia of gear including coupling unit to motor in terms of gear input side ⁴⁾ Torsional stiffness of the gear in terms of gear output side with fixed gear input side								

Fig. 6-1: Transmission-Dependent Data

General data

Designation	Symbol	Unit	58*5
Torsional play ¹⁾	Δφ	arcmin	≤ 3
Service life	L _{10h}	h	30000
Lubricant	-		Oil
permissible ambient temperature	T _{Um}	°C	0...45
Noise level	L _p	dB(A)	<70
Protection category	-		IP 65
Weight	m	kg	22
Mounting for			See section 3.4
¹⁾ in terms of gear output side with 2% gear nominal output torque and fixed gear input side			

Fig. 6-2: General data

6.2 Dimensional Data 58*5 (Axis Distance 80 mm)

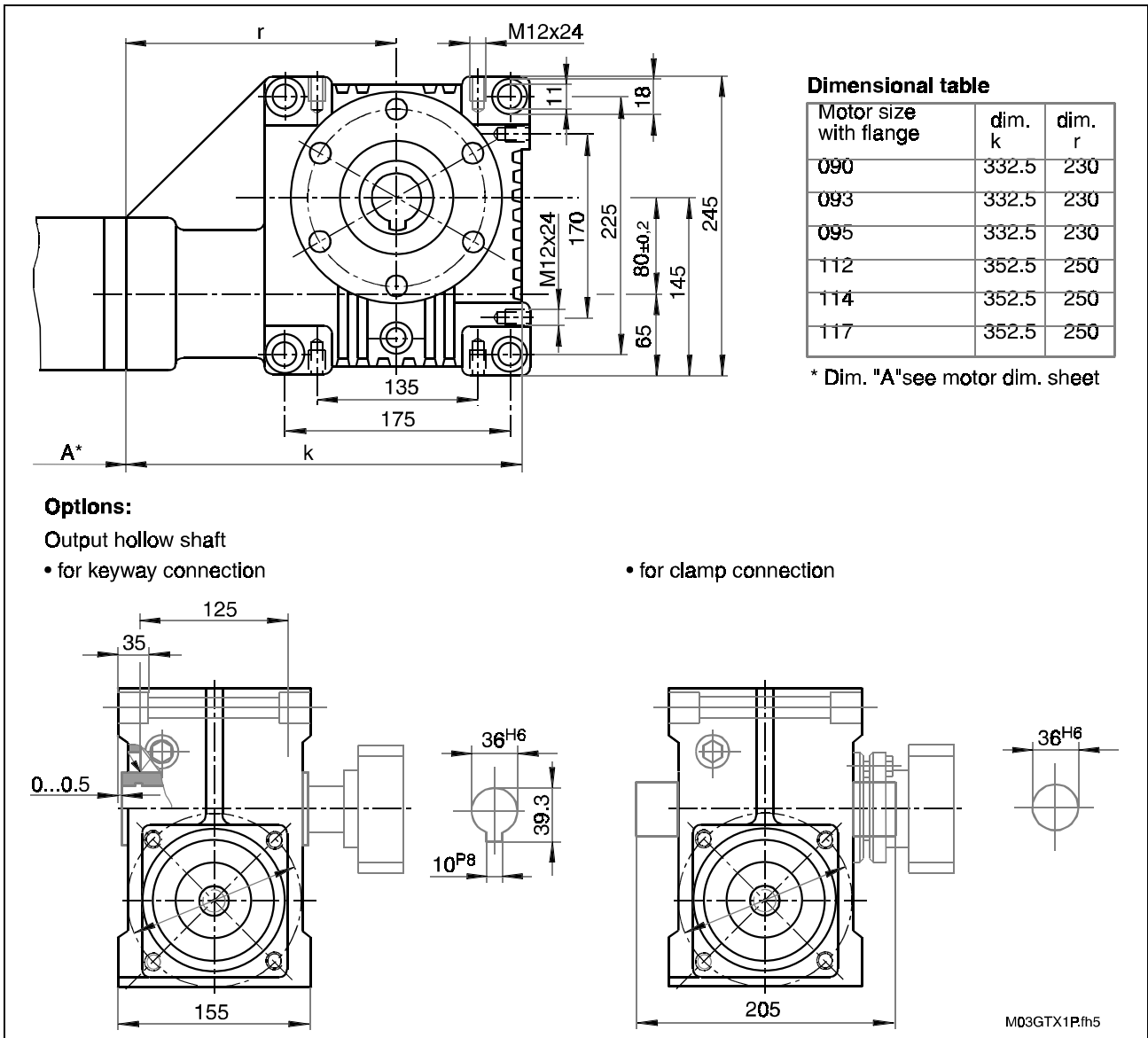

Fig. 6-3: Dimensional data 58*5 (Axis Distance 80 mm)

6.3 Permissible shaft load 58*5 (Axis Distance 80 mm)

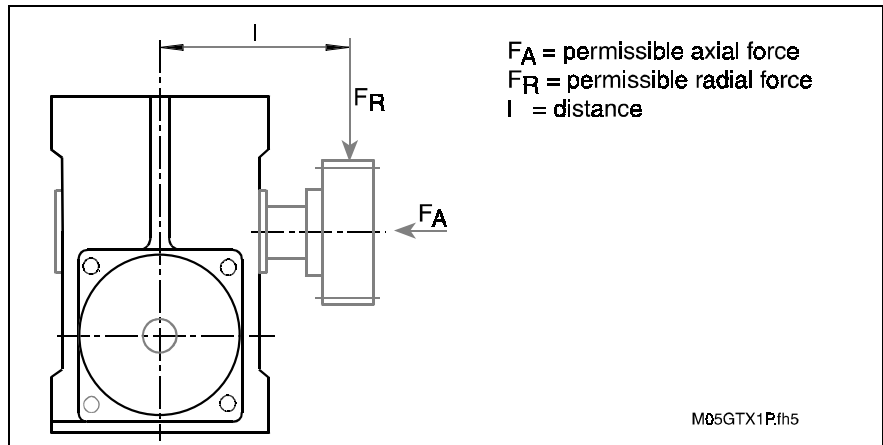

Fig. 6-4: Explanation of the variables influencing permissible shaft load

Permissible radial force

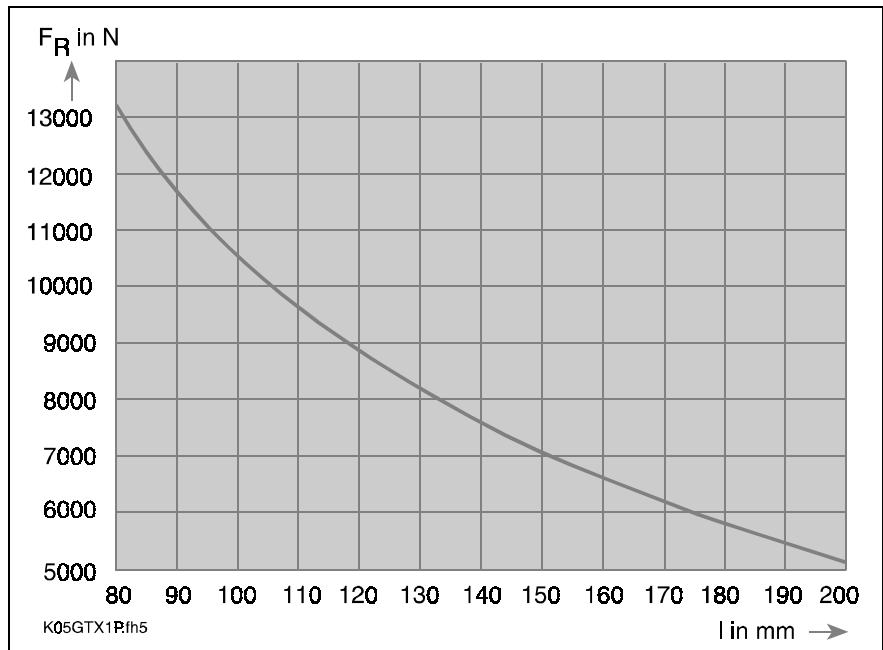

Fig. 6-5: Permissible radial force

Permissible axial force

$F_A = 4000 \text{ N}$

Fig. 6-6: Permissible axial force

6.4 Available Versions

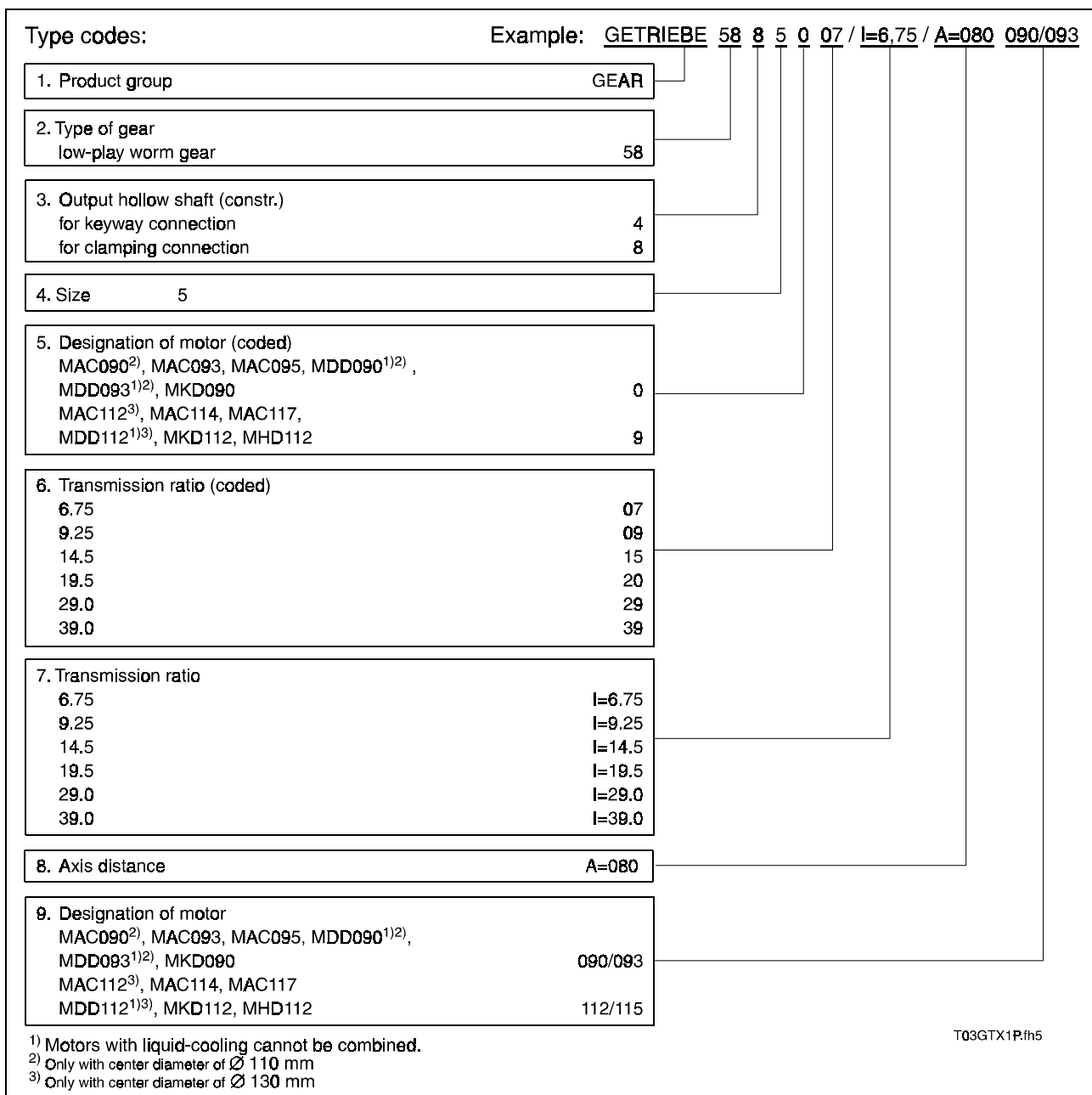

Fig. 6-7: Available versions 58*5 depicted using type codes

7 Worm Gear 58*6 (Axis Distance 100mm)

7.1 Technical Data

Transmission-dependent data

Designation	Symbol	Unit	58*5						
			6.75	9.25	14.5	19.5	39.0		
Transmission ratio	i	-	6.75	9.25	14.5	19.5	39.0		
Maximum input speed ¹⁾	n _{in}	min ⁻¹	3000	3000	3000	3000	3000		
Maximum input torque ²⁾	M _{in,max}	Nm	80.5	59.4	47.6	35.4	22.4		
Maximum output speed	n _{out}	min ⁻¹	444	324	207	154	77		
Maximum output torque ²⁾	M _{out,max}	Nm	500	500	600	600	700		
Power efficiency at standstill	η _o	%	69	68	59	57	38		
Power efficiency at n _{in} = 1500 min ⁻¹	η	%	92	91	87	87	80		
Moment of inertia ³⁾	J	kgcm ²	18.8	14.0	13.1	11.3	14.3		
Torsional stiffness ⁴⁾	D	Nm/rad	340000	340000	340000	340000	340000		
¹⁾ Theoretically possible gear input speed ²⁾ Available for a maximum of 400 ms ³⁾ Mass moment of inertia of gear including coupling unit to motor in terms of gear input side ⁴⁾ Torsional stiffness of the gear in terms of gear output side with fixed gear input side									

Fig. 7-1: Transmission-Dependent Data

General data

Designation	Symbol	Unit	58*6
Torsional play ¹⁾	Δφ	arcmin	≤ 3
Service life	L _{10h}	h	30000
Lubricant	-		Oil
Permissible ambient temperature	T _{Um}	°C	0...45
Noise level	L _p	dB(A)	<70
Protection category	-		IP 65
Weight	m	kg	33
Mounting for			See section 3.4
¹⁾ in terms of gear output side with 2% gear nominal output torque and fixed gear input side			

Fig. 7-2: General data

7.2 Dimensional Data 58*6 (Axis Distance 100 mm)

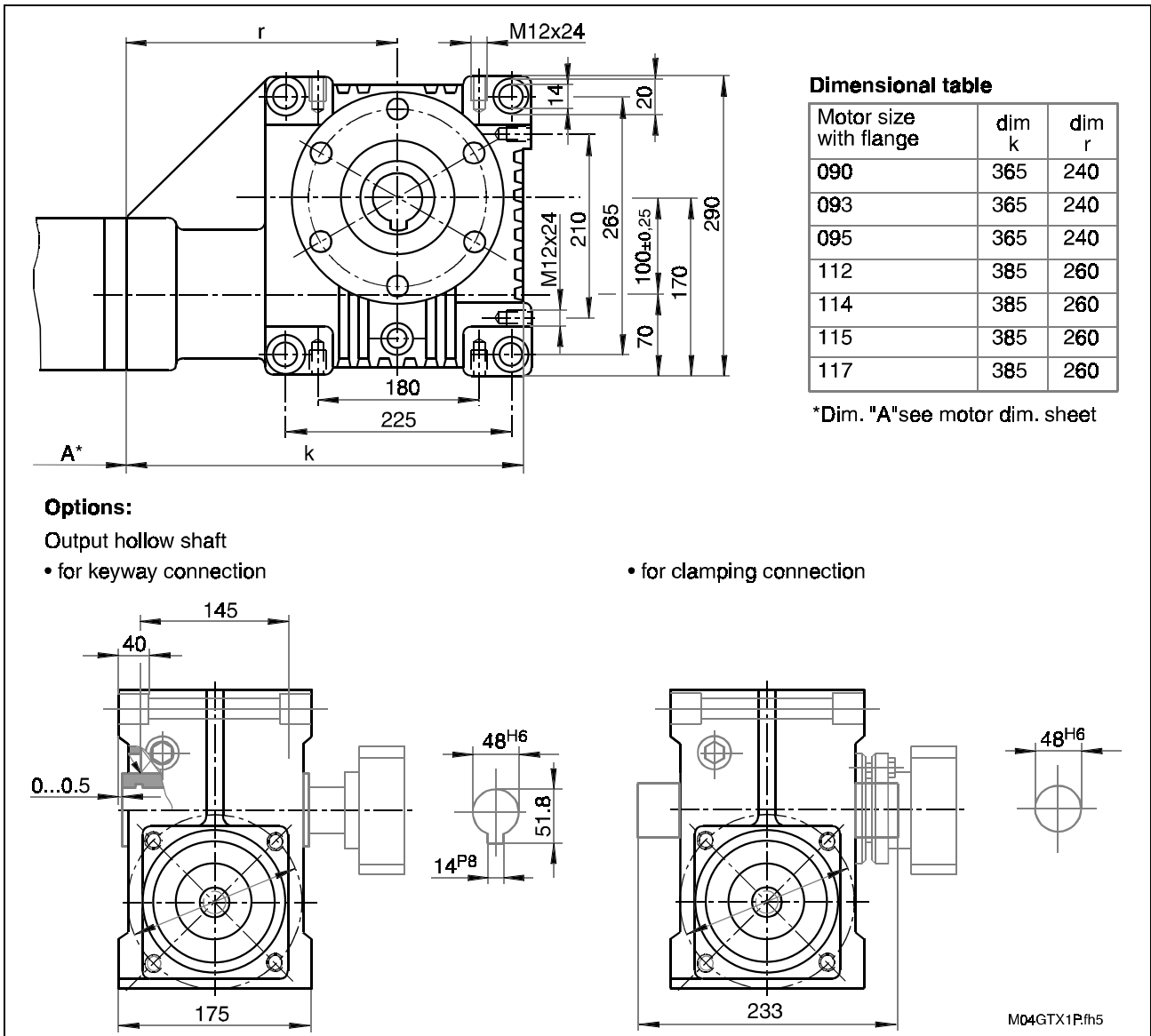

Fig. 7-3: Dimensional data 58*6 (Axis distance 100 mm)

7.3 Permissible Shaft Load 58*6 (Axis Distance 100 mm)

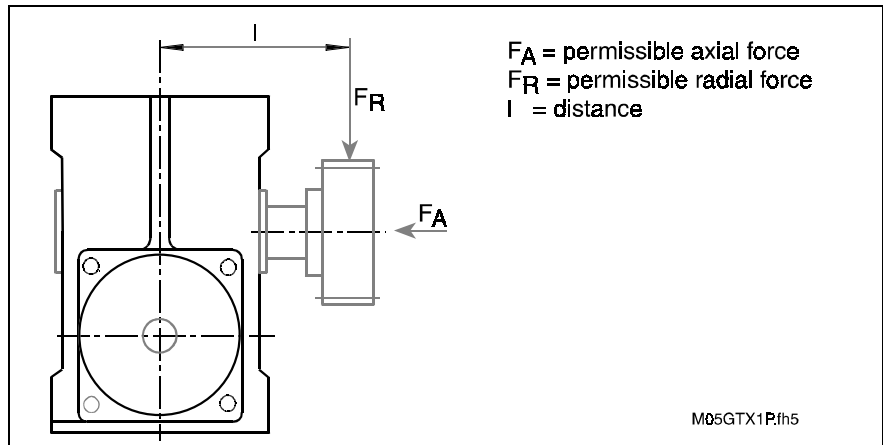

Fig. 7-4: Explanation of the variables influencing permissible shaft load

Permissible radial force

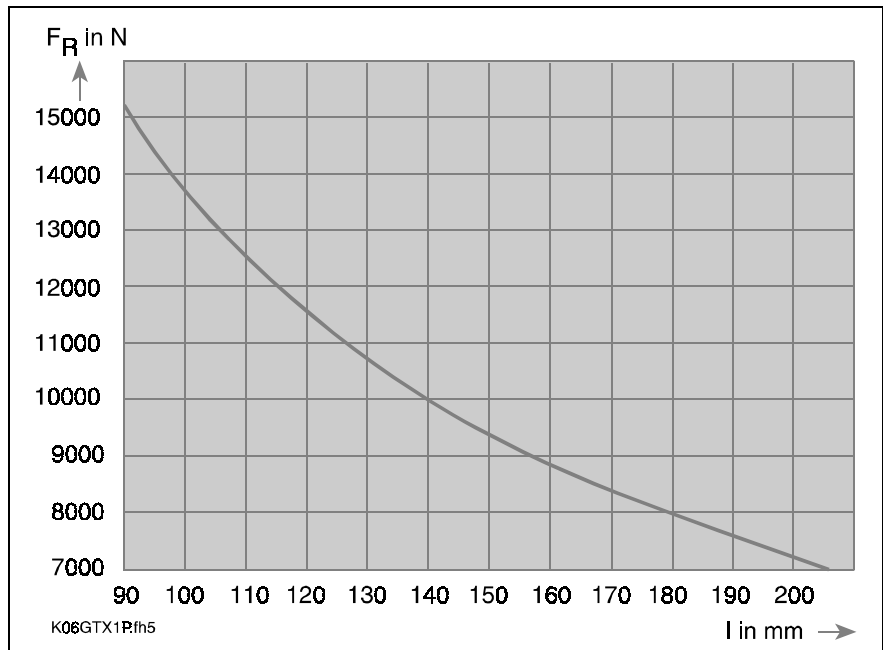

Fig. 7-5: Permissible radial force

Permissible axial force

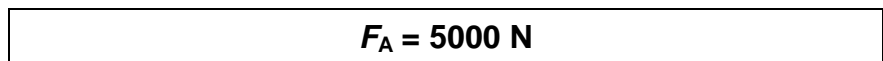

Fig. 7-6: Permissible axial force

7.4 Available Versions

Type codes:	Example: <u>GETRIEBE</u> <u>58</u> <u>8</u> <u>6</u> <u>0</u> <u>07</u> / <u>I=6.75</u> / <u>A=100</u> <u>090/093</u>
1. Product group GEAR	
2. Type of gear low-play worm gear 58	
3. Output hollow shaft (constr.) for keyway connection 4 for clamping connection 8	
4. Size 6	
5. Designation of motor (coded) MAC090 ²⁾ , MAC093, MAC095, MDD090 ¹⁾²⁾ , MDD093 ¹⁾²⁾ , MKD090 0 MAC112 ³⁾ , MAC114, MAC115 ³⁾ , MAC117, MDD112 ¹⁾³⁾ , MDD115 ¹⁾³⁾ , MKD112, MHD112 9	
6. Transmission ratio (coded) 6.75 07 9.25 09 14.5 15 19.5 20 39.0 39	
7. Transmission ratio 6.75 I=6.75 9.25 I=9.25 14.5 I=14.5 19.5 I=19.5 39.0 I=39.0	
8. Axis distance A=100	
9. Designating the motor MAC090 ²⁾ , MAC093, MAC095, MDD090 ¹⁾²⁾ , MDD093 ¹⁾²⁾ , MKD090 090/093 MAC112 ³⁾ , MAC114, MAC115 ³⁾ , MAC117 MDD112 ¹⁾³⁾ , MDD115 ¹⁾³⁾ , MKD112, MHD112 112/115	

¹⁾ Motors with liquid-cooling may not be combined.
²⁾ Only with center diameter of \varnothing 110 mm
³⁾ Only with center diameter of \varnothing 130 mm

T04GTX1P.fh5

Fig. 7-7: Available versions 58*6 depicted using type codes

8 Order Information

The worm gear must be specified as a **sub-item of the AC motor**. A complete unit is always delivered made up of a worm gear 58... and an AC motor.

When ordering the motor, also note that the motor output shaft must be a plain shaft and the center diameter must equal

MAC/MDD 090/093, Ø 110 mm,

MAC/MDD 112/115, Ø 130 mm.

Order example:

1	1	AC Motor
		type: MKD 090B-047-GG0
1.1	1	Worm Gear
		type: GETRIEBE 58 8 5 0 07/l=6.75/A=080 090/093
		mounted to item 1

Notes

9 Service Notes

9.1 Contacting Customer Service

During usual European office hours INDRAMAT customer service can be reached through your nearest Indramat Customer Service Office. Outside of usual office hours, help can be obtained via the following Service Hotline numbers at the hours specified below:

Service Hotline

Tel. **0172 - 660 040 6** or **0171 - 333 882 6**

Monday - Friday 17⁰⁰ - 23⁰⁰ CET

Saturday 8⁰⁰ - 20⁰⁰ CET

Sunday and holidays 9⁰⁰ - 19⁰⁰ CET

To ensure a quick elimination of the problems and faults, please make a note of the following information before contacting INDRAMAT customer service, namely,

- the type designations of controller, motor and gearbox
- the fault state
- any fault and diagnostic displays.

When returning the gears, please include the Fault Report included in this document. It can be found in section 9.2 and can be copied. It will help locate the problems.

9.2 Fault Report

Completed by:		Co.	/	Loc.	Date
Gear type:			Serial no.:		
Motor type:			Serial no.:		
Machine type	Machine no.		Mach. manif.		
Startup date	Down date		Oper. time		
State <input type="checkbox"/> increased noise <input type="checkbox"/> gear untight <input type="checkbox"/> gear blocked <input type="checkbox"/> break in output shaft <input type="checkbox"/> other			Cause <input type="checkbox"/> unknown <input type="checkbox"/> incorrect use <input type="checkbox"/> collision <input type="checkbox"/> other		
Description of the problem:					
Operating conditions: average on time/day: <input type="text"/> hours Oper. mode: S <input type="checkbox"/> cycles/hours <input type="text"/> <input type="checkbox"/> Reverse operation Orientation: Ambient temperature: <input type="text"/> °C <input type="checkbox"/> horizontal Output situation: <input type="checkbox"/> vertical, output shaft down <input type="checkbox"/> pinion for rack-and-pinion drive <input type="checkbox"/> vertical, output shaft up <input type="checkbox"/> belt pulley <input type="checkbox"/> other <input type="checkbox"/> customer output element <input type="checkbox"/> other					
U01GTX1B.th5					

Fig. 9-1: Fault Report

Directory of Customer Service Locations

Germany

Sales region central INDRAMAT GmbH D-97816 Lohr am Main Bgm.-Dr.-Nebel-Str. 2 Telefon: 09352/40-0 Telefax: 09352/40-4885	Sales region east INDRAMAT GmbH D-09120 Chemnitz Beckerstraße 31 Telefon: 0371/3555-0 Telefax: 0371/3555-230	Sales region West INDRAMAT GmbH D-40849 Ratingen Hansastraße 25 Telefon: 02102/4318-0 Telefax: 02102/41315	Sales region north INDRAMAT GmbH D-22085 Hamburg Fährhausstraße 11 Telefon: 040/227126-16 Telefax: 040/227126-15
Sales region south INDRAMAT GmbH D-80339 München Ridlerstraße 75 Telefon: 089/540138-30 Telefax: 089/540138-10	Sales region southwest INDRAMAT GmbH D-71229 Leonberg Böblinger Straße 25 Telefon: 07152/972-6 Telefax: 07152/972-727		INDRAMAT Service-Hotline INDRAMAT GmbH Telefon: D-0172/660 040 6 -or- Telefon: D-0171/333 882 6

Customer Service locations in Germany

Europe

Austria G.L.Rexroth Ges.m.b.H. Geschäftsbereich INDRAMAT A-1140 Wien Hägelingasse 3 Telefon: 1/9852540-400 Telefax: 1/9852540-993	Austria G.L.Rexroth Ges.m.b.H. Geschäftsbereich INDRAMAT A-4061 Pasching Randlstraße 14 Telefon: 07229/4401-36 Telefax: 07229/4401-80	Belgium Mannesmann Rexroth N.V.-S.A. Geschäftsbereich INDRAMAT B-1740 Ternat Industrielaan 8 Telefon: 02/5823180 Telefax: 02/5824310	Denmark BEC Elektronik AS DK-8900 Randers Zinkvej 6 Telefon: 086/447866 Telefax: 086/447160
England Mannesmann Rexroth Ltd. INDRAMAT Division Cirencester, Glos GL7 1YG 4 Esland Place, Love Lane Telefon: 01285/658671 Telefax: 01285/654991	Finnland Rexroth Mecman OY SF-01720 Vantaa Riihimiehentie 3 Telefon: 0/848511 Telefax: 0/846387	France Rexroth - Sigma S.A. Division INDRAMAT F-92632 Gennevilliers Cedex Parc des Barbanniers 4, Place du Village Telefon: 1/41475430 Telefax: 1/47946941	France Rexroth - Sigma S.A. Division INDRAMAT F-69634 Venissieux - Cx 91, Bd 1 Joliot Curie Telefon: 78785256 Telefax: 78785231
France Rexroth - Sigma S.A. Division INDRAMAT F-31100 Toulouse 270, Avenue de l'ardenne Telefon: 61499519 Telefax: 61310041	Italy Rexroth S.p.A. Divisione INDRAMAT I-20063 Cernusco S/N.MI Via G. Di Vittoria, 1 Telefon: 02/92365-270 Telefax: 02/92108069	Italy Rexroth S.p.A. Divisione INDRAMAT Via Borgomanero, 11 I-10145 Torino Telefon: 011/7712230 Telefax: 011/7710190	Netherlands Hydraudyne Hydrauliek B.V. Kruisbroeksestraat 1a P.O. Box 32 NL-5280 AA Boxtel Telefon: 04116/51951 Telefax: 04116/51483
Spain Rexroth S.A. Centro Industrial Santiago Obradors s/n E-08130 Santa Perpetua de Mogoda (Barcelona) Telefon: 03/718 68 51 Telex: 591 81 Telefax: 03/718 98 62	Spain Goimendi S.A. División Indramat Jolastokieta (Herrera) Apartado 11 37 San Sebastian, 20017 Telefon: 043/40 01 63 Telex: 361 72 Telefax: 043/39 93 95	Sweden AB Rexroth Mecman INDRAMAT Division Varuvägen 7 S-125 81 Stockholm Telefon: 08/727 92 00 Telefax: 08/64 73 277	Switzerland Rexroth SA Département INDRAMAT Chemin de l'Ecole 6 CH-1036 Sullens Telefon: 021/731 43 77 Telefax: 021/731 46 78
Switzerland Rexroth AG Geschäftsbereich INDRAMAT Gewerbestraße 3 CH-8500 Frauenfeld Telefon: 052/720 21 00 Telefax: 052/720 21 11	Russia Tschudnenko E.B. Arsenia 22 153000 Ivanovo Rußland Telefon: 093/22 39 633		

European customer service locations without Germany

Outside of Europe

<p>Argentina</p> <p>Mannesmann Rexroth S.A.I.C. Division INDRAMAT Acassusso 48 41/7 1605 Munro (Buenos Aires) Argentina Telefon: 01/756 01 40 01/756 02 40 Telex: 262 66 rexro ar Telefax: 01/756 01 36</p>	<p>Argentina</p> <p>Nakase Asesoramiento Tecnico Diaz Velez 2929 1636 Olivos (Provincia de Buenos Aires) Argentina Argentina Telefon 01/790 52 30</p>	<p>Australia</p> <p>Australian Industrial Machinery Services Pty. Ltd. Unit 3/45 Horne ST Campbellfield VIC 2061 Australia Telefon: 03/93 59 0228 Telefax: 03/93 59 02886</p>	<p>Brazil</p> <p>Mannesmann Rexroth Automação Ltda. Divisão INDRAMAT Rua Georg Rexroth, 609 Vila Padre Anchieta BR-09.951-250 Diadema-SP Caixa Postal 377 BR-09.901-970 Diadema-SP Telefon: 011/745 90 65 011/745 90 70 Telefax: 011/745 90 50</p>
<p>Canada</p> <p>Basic Technologies Corporation Burlington Division 3426 Mainway Drive Burlington, Ontario Canada L7M 1A8 Telefon: 905/335-55 11 Telefax: 905/335-41 84</p>	<p>China</p> <p>Rexroth (China) Ltd. Shanghai Office Room 206 Shanghai Intern. Trade Centre 2200 Yanan Xi Lu Shanghai 200335 P.R. China Telefon: 021/627 55 333 Telefax: 021/627 55 666</p>	<p>China</p> <p>Rexroth (China) Ltd. Shanghai Parts & Service Centre 199 Wu Cao Road, Hua Cao Minhang District Shanghai 201 103 P.R. China Telefon: 021/622 00 058 Telefax: 021/622 00 068</p>	<p>China</p> <p>Rexroth (China) Ltd. 1430 China World Trade Centre 1, Jianguomenwai Avenue Beijing 100004 P.R. China Telefon: 010/50 50 380 Telefax: 010/50 50 379</p>
<p>China</p> <p>Rexroth (China) Ltd. A-5F., 123 Lian Shan Street Sha He Kou District Dalian 116 023 P.R. China Telefon: 0411/46 78 930 Telefax: 0411/46 78 932</p>	<p>Honkong</p> <p>Rexroth (China) Ltd. 19 Cheung Shun Street 1st Floor, Cheung Sha Wan, Kowloon, Honkong Telefon: 741 13 51/-54 und 741 14 30 Telex: 3346 17 GL REX HX Telefax: 786 40 19 786 07 33</p>	<p>India</p> <p>Mannesmann Rexroth (India) Ltd. INDRAMAT Division Plot. 96, Phase III Peenya Industrial Area Bangalore - 560058 Telefon: 80/839 21 01 80/839 73 74 Telex: 845 5028 RexB Telefax: 80/839 43 45</p>	<p>Japan</p> <p>Rexroth Co., Ltd. INDRAMAT Division I.R. Building Nakamachidai 4-26-44 Tsuzuki-ku, Yokohama 226 Japan Telefon: 045/942-72 10 Telefax: 045/942-03 41</p>
<p>Korea</p> <p>Rexroth-Seki Co Ltd. 1500-12 Da-Dae-Dong Saha-Gu, Pusan, 604-050 Telefon: 051/264 90 01 Telefax: 051/264 90 10</p>	<p>Korea</p> <p>Seo Chang Corporation Ltd. Room 903, Jeail Building 44-35 Yoido-Dong Youngdeungpo-Ku Seoul, Korea Telefon: 02/780-82 07 -9 Telefax: 02/784-54 08</p>	<p>Mexico</p> <p>Motorización y Diseño de Controles, S.A. de C.V. Av. Dr. Gustavo Baz No. 288 Col. Parque Industrial la loma Apartado Postal No. 318 54060 Tlalnepanla Estado de Mexico Telefon: 5/397 86 44 Telefax: 5/398 98 88</p>	
<p>USA</p> <p>Rexroth Corporation INDRAMAT Division 5150 Prairie Stone Parkway Hoffman Estates, Illinois 60192 Telefon: 847/645-36 00 Telefax: 857/645-62 01</p>	<p>USA</p> <p>Rexroth Corporation INDRAMAT Division 2110 Austin Avenue Rochester Hills, Michigan 48309 Telefon: 810/853-82 90 Telefax: 810/853-82 90</p>		

Customer Service locations outside of Europe

Notes

