

APM212 Gear Motors, including Fan Drive Gear Motors

Standard and Low Noise series

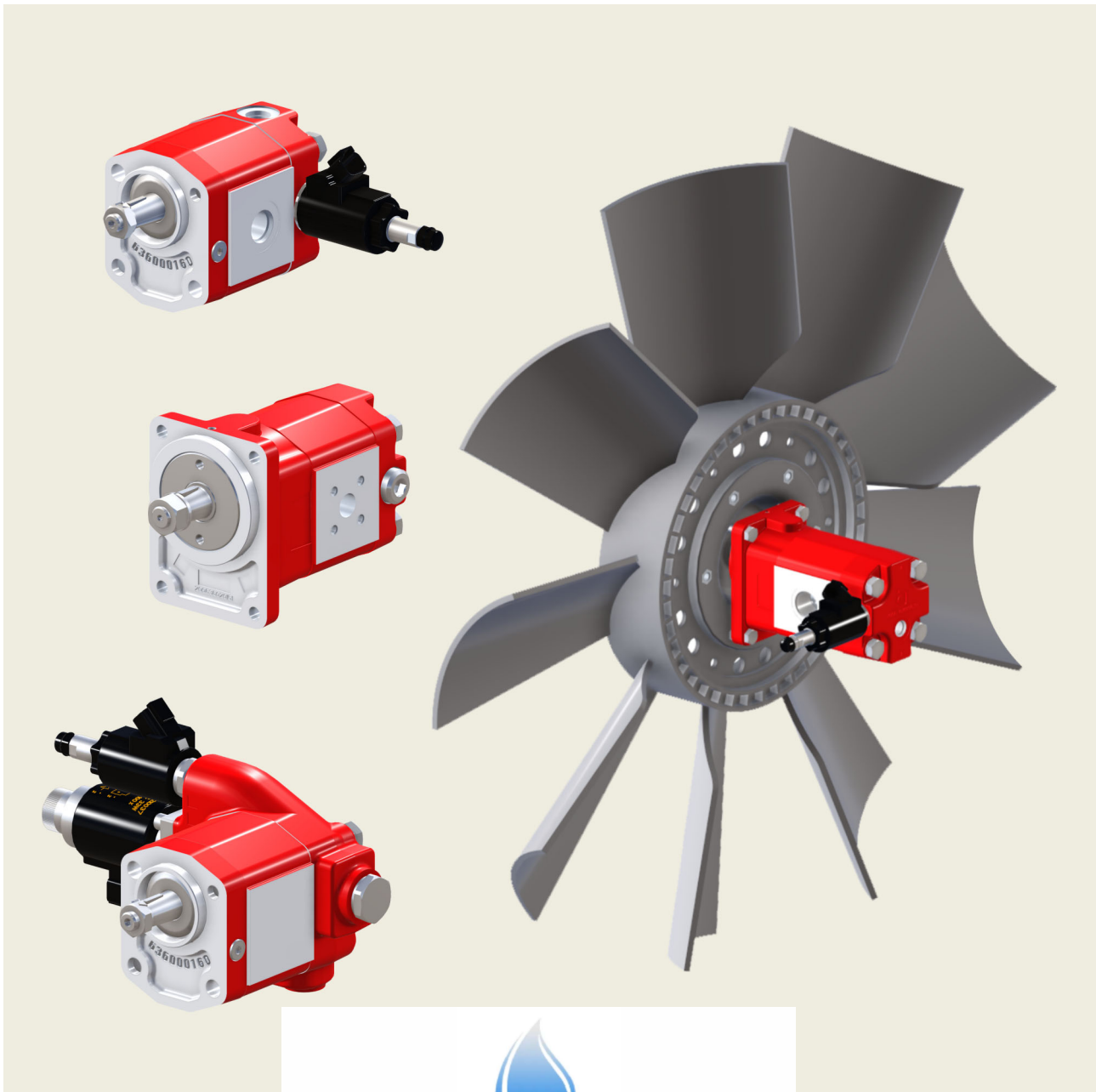

OIL SOLUTIONS

PO Box 38
Strathfieldsaye, VIC, 3551
1800 OIL SOL
1800 645 765

sales@oilsolutions.com.au

www.oilsolutions.com.au

"For All Your Hydraulic Needs"

1	General information	3
1.1	External gear motors for general use	3
1.2	Fan Drive Gear Motors for cooling systems	4
1.3	External gear motors components	5
1.4	Example of typical sound pressure level recorded in a semi-anechoic testing room	6
1.5	Technical data	7
1.6	High inlet pressure	7
1.7	Identifying the rotation direction	8
1.8	Outlet	8
1.9	Radial and axial load	9
1.10	Application check	9
1.11	General installation precaution	11
1.12	Directives and standards	12
1.13	Non-standard symbols used in the text	12
1.14	Gear motor formulas	12
1.15	Diagrams APM212	13
<hr/>		
2	Overview standard types (General use)	15
2.1	Standard configuration	15
<hr/>		
3	APM212 customised versions (Cooling systems or other applications)	31
3.1	Customised versions order example	32
3.2	Single motor dimensions	33
3.3	Shaft end code	34
3.4	Front cover	35
3.5	Body	38
3.6	Back covers	41
3.7	Valves and circuits	42
<hr/>		
4	Accessories	50
4.1	Electronic module, ESLF series	50
4.2	External manifold for reversing control, STB series	52
<hr/>		
5	Product identification plate	55
<hr/>		
6	Application form	56

1 General information

External gear motors are widely used in modern hydraulic systems due to their high performance, long service life and low maintenance costs.

With the new APM212 family, high operating pressures, excellent volumetric and mechanical efficiencies were achieved; moreover, for LN-series (Low Noise versions), definitely better acoustic performances were obtained.

Different features of the new APM design were deeply analyzed and studied in order to get to the above mentioned results; primarily, engineering attention was focused on the design of the gear teeth and balancing areas but also

materials, heat treatments and coupling tolerances were carefully considered during the development process; these project variables linked to a continuous tight test schedule (even performed in our semi-anechoic room) were the tools adopted by Bucher to achieve the excellent performance of these gear motors.

Bucher Hydraulics philosophy is based on continuous improving; this concept is enforced by high-end control and manufacturing techniques in Production and by a Quality Control System which guarantees that every single product can offer the same high standard level.

1.1 External gear motors for general use

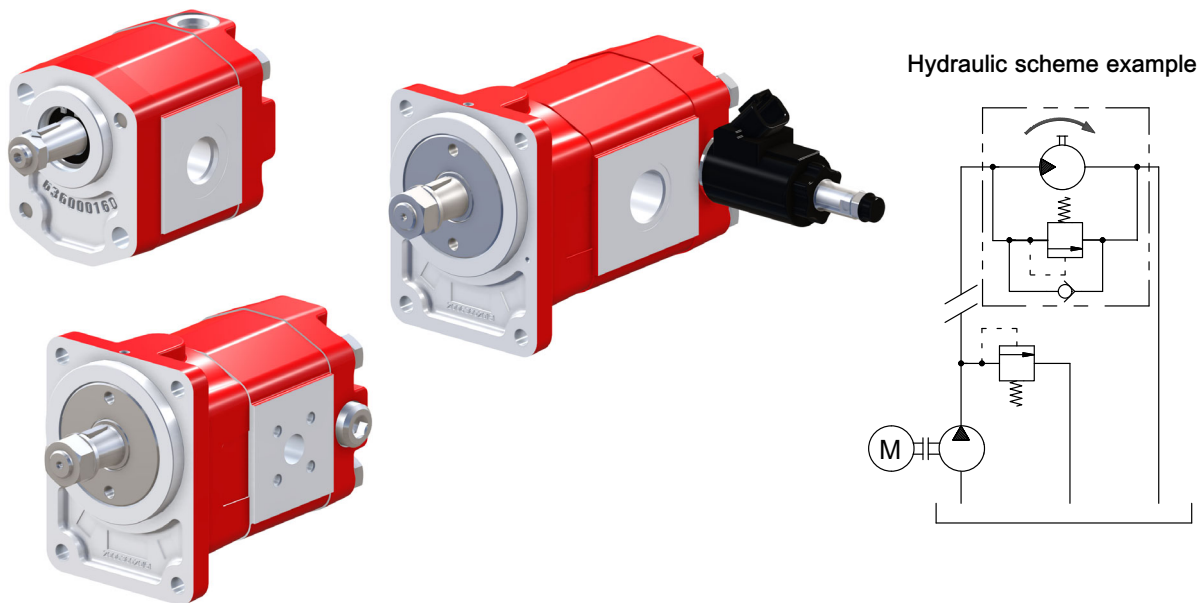

New APM212 motors benefits

- High hydraulic and mechanical efficiencies
- Able to withstand high pressure
- Long life due to optimised materials used
- Low Noise and vibration features available also in "standard" version
- Low Noise motors with new gears profile available
- outrigger bearing available

Examples of typical applications



1.2 Fan Drive Gear Motors for cooling systems

In the Fan Drive Gear Motors for cooling systems we implemented the shaft seal protection adding a dedicated sealing. Consequently, dedicated cast iron front covers have been designed. See section 3.4.2



New APM212 motors benefits

- Improve machine operating efficiency
- Reduce the costs of maintenance
- Reduce noise and vibrations
- Allow to integrate hydraulic values circuit
- Electronic control available

Examples of typical applications

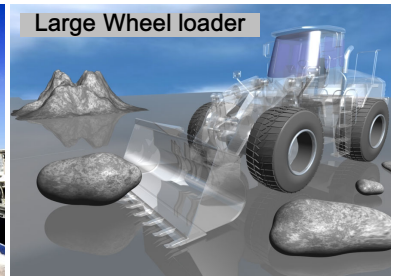

Hydraulic scheme examples

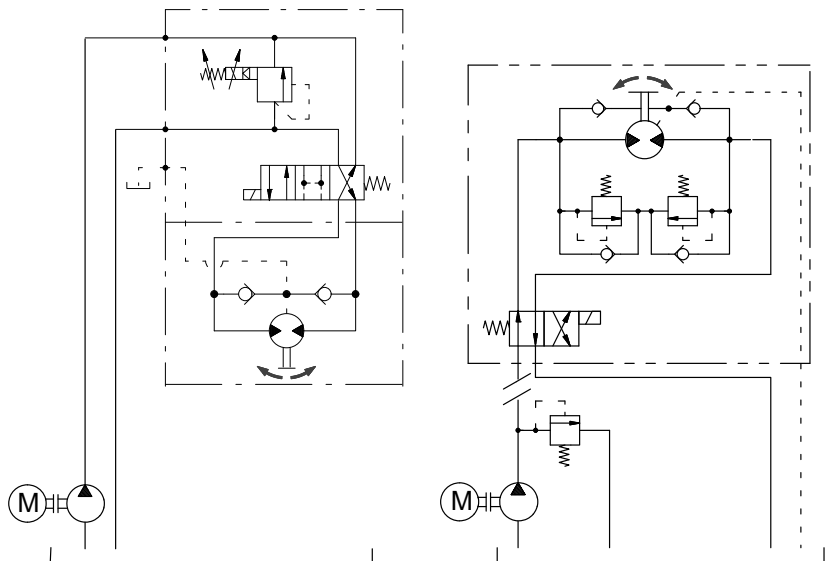

1.3 External gear motors components

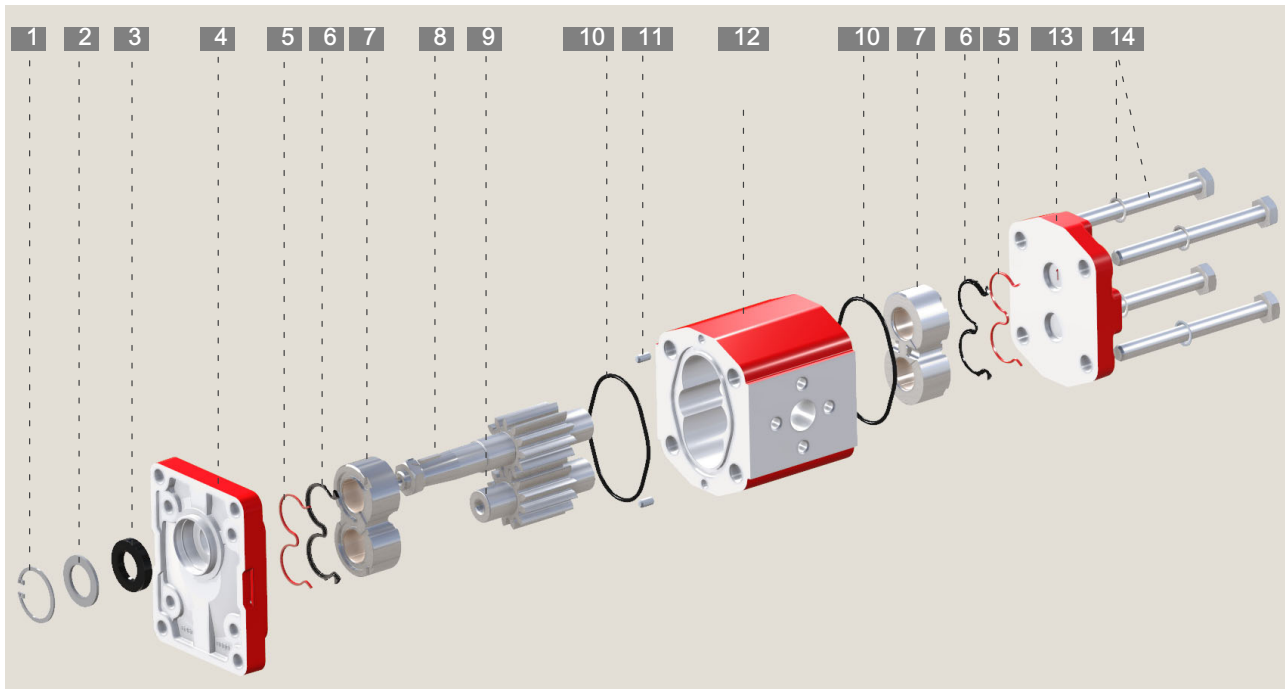

1. Retaining ring
2. Shaft seal ring support
3. Shaft seal
4. Front cover
5. Back up seal
6. Balancing seal
7. Balancing block

8. Take off power gear
9. Gear
10. Oil seal
11. Centering pin
12. Motor body
13. Back cover
14. Fixing screw and washer

1.3.1 Improvements (New APM212 vs APM200)

Front covers :

In addition to aluminium versions, complete new range of cast iron front covers

Balancing blocks :

New generation optimised and standardised balancing blocks

Gears :

New gears profile (12 teeth) and increased transmissible torque

Bodies:

New design pump bodies

Back covers :

Wide range of aluminium and cast iron back covers with/without integrated cartridge valves

Seals :

As general rule, shaft seal (Pos.3), balancing seals (Pos.6) and body oil seals (Pos.10) are in HNBR material.

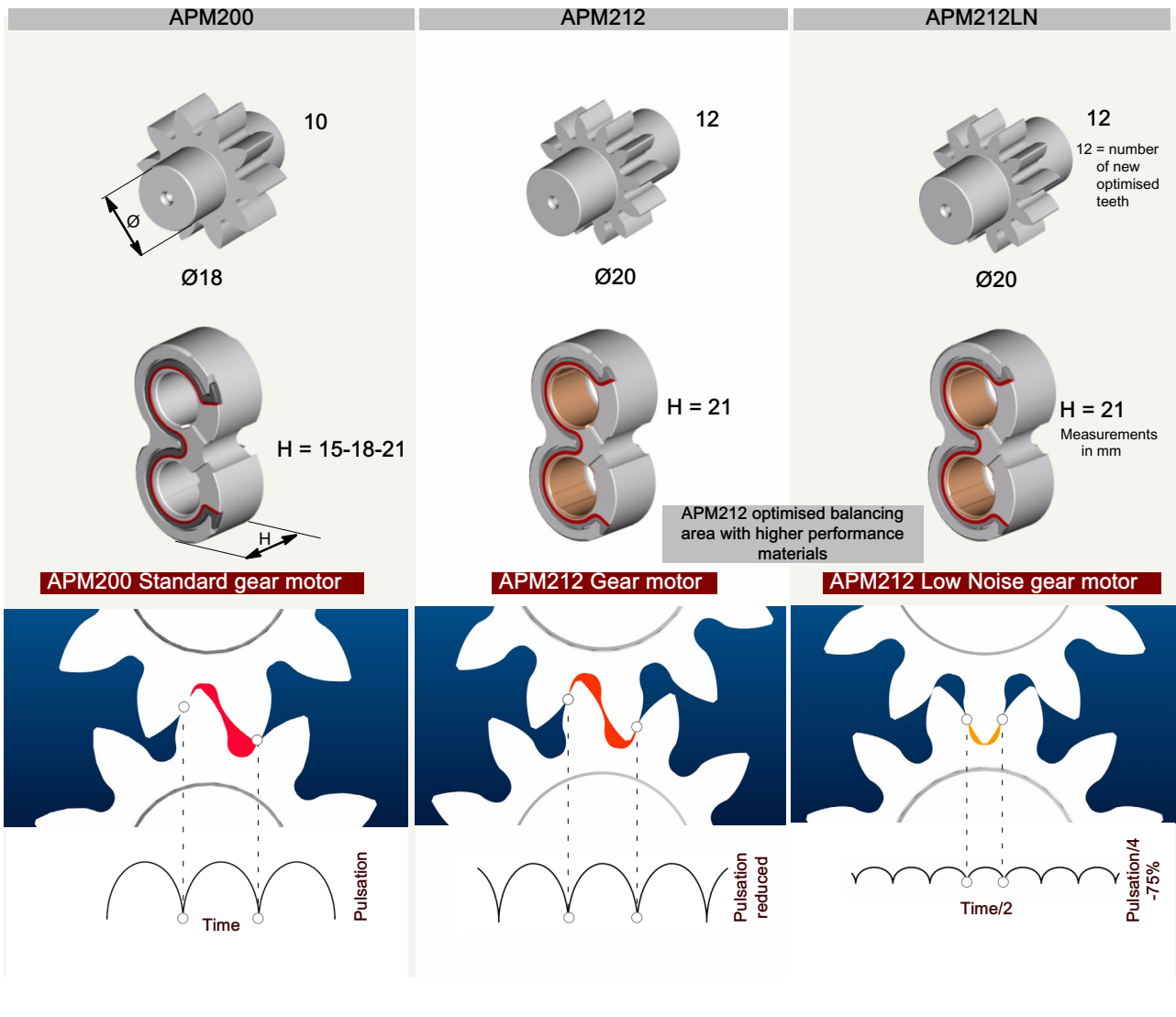

1.4 Example of typical sound pressure level recorded in a semi-anechoic testing room

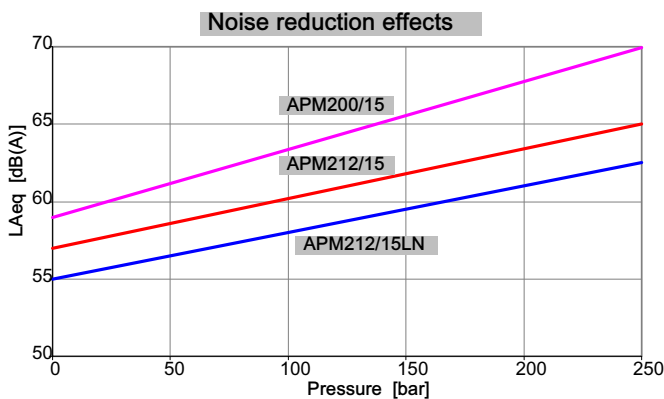

Oil temperature: 40°C - Oil viscosity: 32 mm²/s
 Distance between motor and sensor: 1 m
 Speed: 1500 rpm

1.7 Identifying the rotation direction

The rotation direction of a gear motor is identified by looking at the motor from the front and with the drive gear turned upwards (see figures below).

Motors with clockwise rotation (D) have a drive gear which turns clockwise, with the inlet port on the left and the outlet port on the right.

Motors with counterclockwise rotation (S) have a drive gear which turns counterclockwise, with the inlet port on the right and the outlet port on the left.

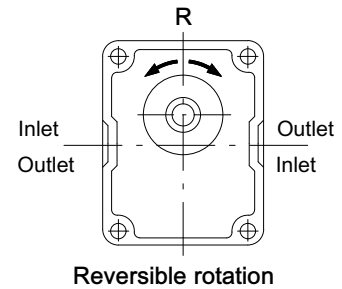
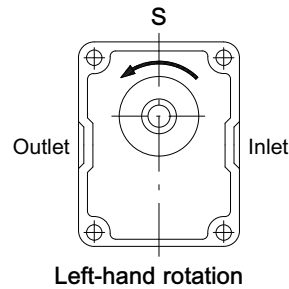
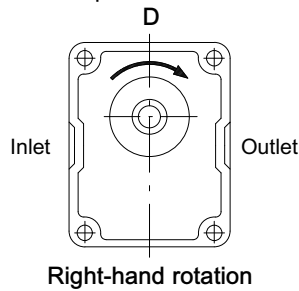

The figure also shows the pressure flow inside the motors as the oil is transferred from the inlet port to the outlet port. As regards reversible motors (R), the ports are alternatively for inlet and outlet.

Motors with a unidirectional rotation (D or S) have the denomination APM. Motors with reversible rotation have the denomination APMR.

Motors with "Low Noise" components have the denomination LN.

1.8 Outlet

1.8.1 Unidirectional motors

As a matter of principle, unidirectional motors correspond to counter rotating pumps.

The balancing seals are not symmetric and, consequently, two different pressure sides: inlet High-pressure and outlet Low-pressure side, which must not be exchanged each other, are defined.

The outlet Low-pressure side loads the back side of the oil retaining shaft seal, a dedicated steel ring for supporting it, is adopted.

The maximum outlet Low-pressure value is limited by the shaft seal and its support, see limit indications, page 10/56

To keep P_{out} below the suggested value, the following must be avoided:

- long distance between motor and tank
- long stretches of piping
- special features such as: bends; reductions in diameter;

quick couplings; etc.

Having filtration on the return it is also advisable to choose a filter of a suitable size to minimise any pressure drop and to take measures to prevent gradual clogging over time.

1.8.2 Reversible motors

Reversible rotating motors have symmetric balancing seals and both port, inlet and outlet, can be, alternatively, operate as inlet High-pressure and outlet Low-pressure port.

A sealed area is connected to the back side of the oil retaining shaft seal and its pressure must be limited connecting it to the tank, through a drain threaded port, which is generally, placed on the motor rear cover.

The drain hose must be chosen in order to avoid that the pressure at the drain port does not exceed the maximum admitted pressure, see limit indications, page 10/56.

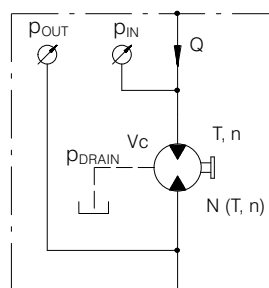
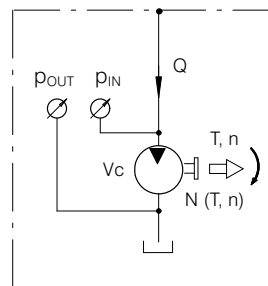

1.9 Radial and axial load

1.9.1 Standard version

Bucher APM212 gear motors are suitable to work also when radial and axial loads are applied to it.

In order to guarantee the correct life of the hydraulic motor, it is necessary to let the component work within the limits indicated in the table below:

Radial load	100 N
Axial load	500 N

1.9.2 Bearing front cover support

High values of radial and axial loads can cause the wear of the motor internal components; as a consequence, motor performance and life can be dramatically reduced.

Bucher Hydraulics studied special front covers having a bearing on-board which allow the motor to tolerate loads higher than the previous ones shown in 1.9.1

When the hydraulic motor is assembled in an application using a coupling, the joint must be able to absorb any discrepancies in the coaxial alignment of the gear motor-driven shaft without applying any loads on the motor shaft.

In the coupling between splined shafts, the connection sleeve must be free to move along its axis; the length of

What shown must be considered the worst load conditions which our motors have to submit to.

Radial load: the maximum admissible radial loads must be calculated considering both the fan weight and the unbalanced mass.

Axial load: the limits of axial loads apply to both directions (in inwards and in outwards).

When radial and/or axial loads exceed the above stated values, a front bearing support must be adopted.

this sleeve must be sufficient to fully cover the splined sections of the motor-driven shaft in any of its positions. A clearance between shaft ends is necessary.

It's important to check that the spline coupling is reasonably lubricated allowing its protection against a rapid deterioration.

Should any radial and/or axial loads be applied to the take-off-shaft (e.g. when it is coupled to a V-belt and pulley or to a pair of gear wheels), a front cover with supporting bearings.

Depending on the motor model, these supports can replace the front cover of the motor or can be fitted in addition to it (assembling it on the front cover itself).

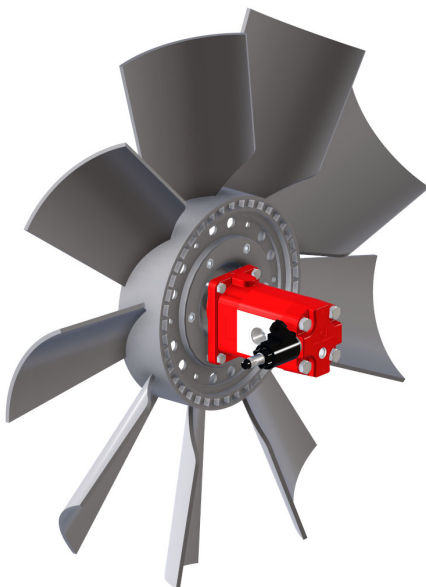

1.10 Application check

In order to extend the life of the gear motor (which depends on motor speed, system pressure, and other system parameters), Bucher Hydraulics strongly recommends the following actions:

- **Perform a prototype testing programme** in order to check its functionality and its behaviour with the machine which will be equipped with this component.
- **Avoid cavitation;** every action which reduces the quantity of air trapped in the system is worth to extend all system components life.

- **A maintenance of the fluid and of the filtering system** has to be regularly accomplished. A clean fluid can extend the life of the system reducing its consequent failures.

Before to introduce the motor into the machine it is necessary to check if the application match the motor specifications. In particular:

1. Pressure limits

It is important to remain inside the catalogue limits as P1 (continuous) and P3 (peak) see section 1.5.

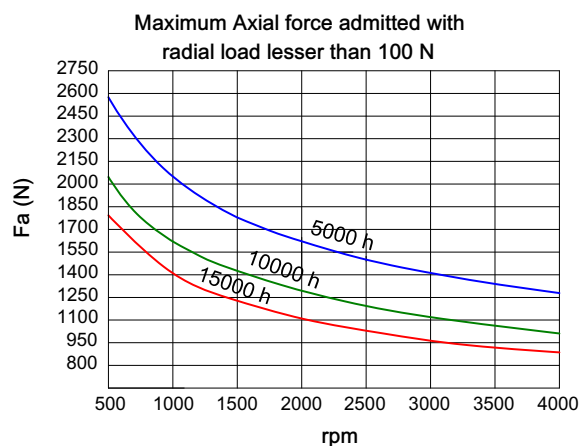

2. Return line and/or case drain line

The case drain line must be connected directly to tank if possible using a dedicated connection. The connection size should be dimensioned with appropriated internal passage

in order to maintain as low as possible the pressure inside. The max allowed pressure depending on the speed and the viscosity. See limits indications.

Limit indications:

Shaft seal: Maximum pressure admitted

 **IMPORTANT!** The pressure on the outlet line has to be checked in order to choose the right motor configuration. Different solutions are available depending on pressure value recorded. See examples from 1 to 4

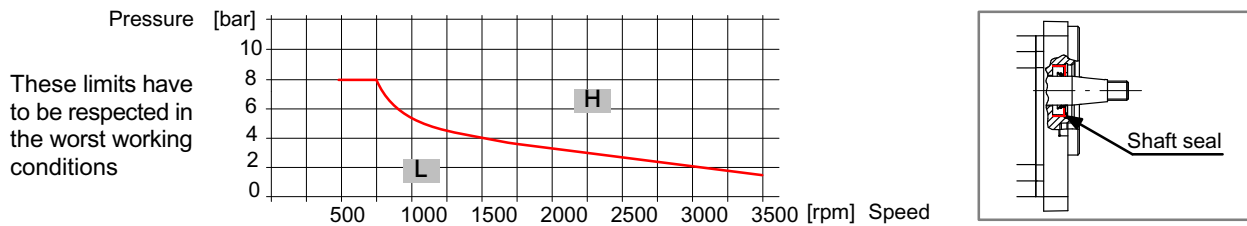

1 Unidirectional motor APM

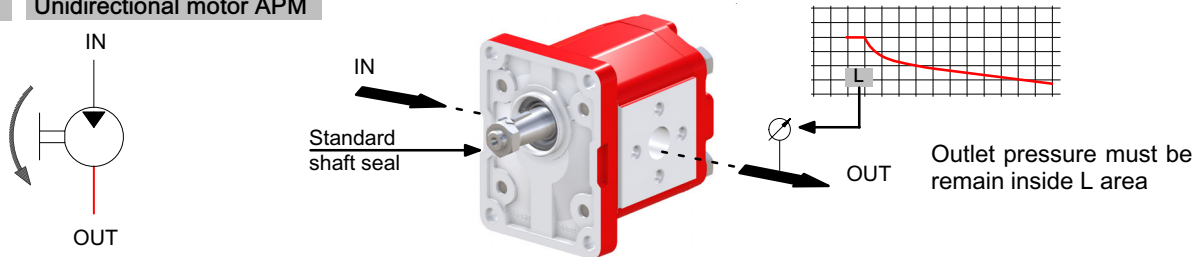

2 Bidirectional motor used in only one direction

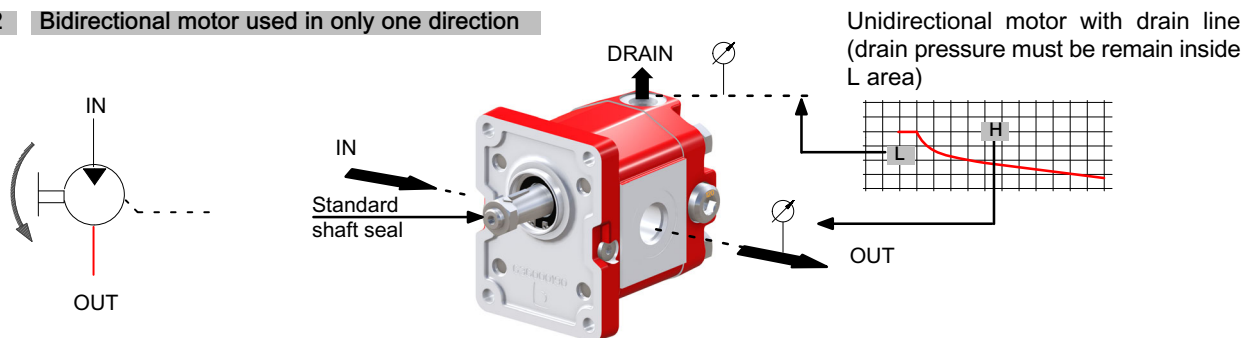

3 Unidirectional motor APM

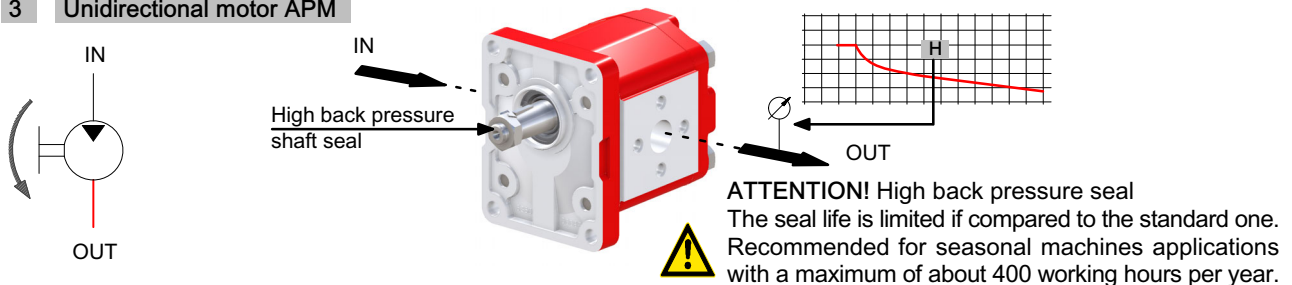

4 Bidirectional motor APMR

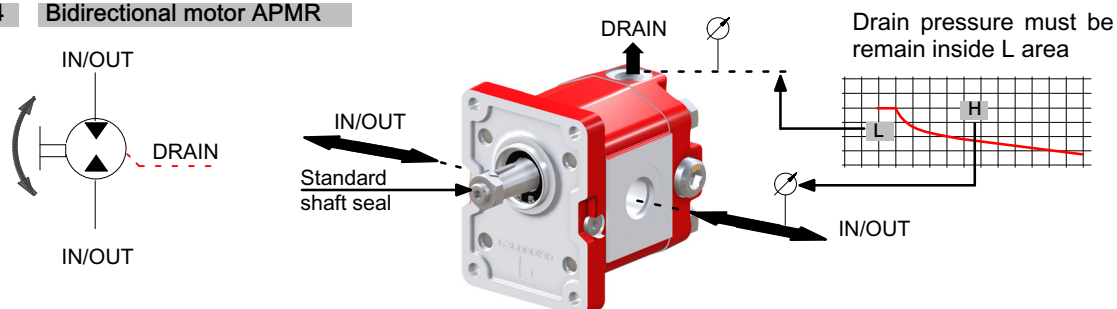

1.11 General installation precaution

In addition to the recommendations regarding fluids, filtration, coupling, etc., we suggest the following:

- For unidirectional motors check always the rotation direction of the motor's take off shaft; it must be compatible with the rotation direction of the motor itself.
- Be particularly careful in cleaning and make sure, when connecting the high and low pressure piping, that no chips, rag threads, teflon tape, etc. get into the motor circulation system.
- Check the tightness of the high and low pressure fittings, the correct positioning of the O-Ring, and make sure there is no dirt between the flange and the motor body.
- To ensure the best heat distribution inside the tank,

make sure the return pipe is not too close to the pump's suction piping.

The pipes themselves should be below oil tank level to prevent the formation of foam.

- Do not subject the motors to operating conditions different from those indicated on section 1.5 ; for extreme operations, always contact our Technical Department.
- Never use fluids different from those indicated in section 1.5.
- Ambient temperature range: $-20 / +50\text{ }^{\circ}\text{C}$
- In the event of motor painting, do not use solvents or paints that are incompatible with the material of the seals. Do not bake paint with excessively high temperatures.

Example of several hydraulic circuits available:

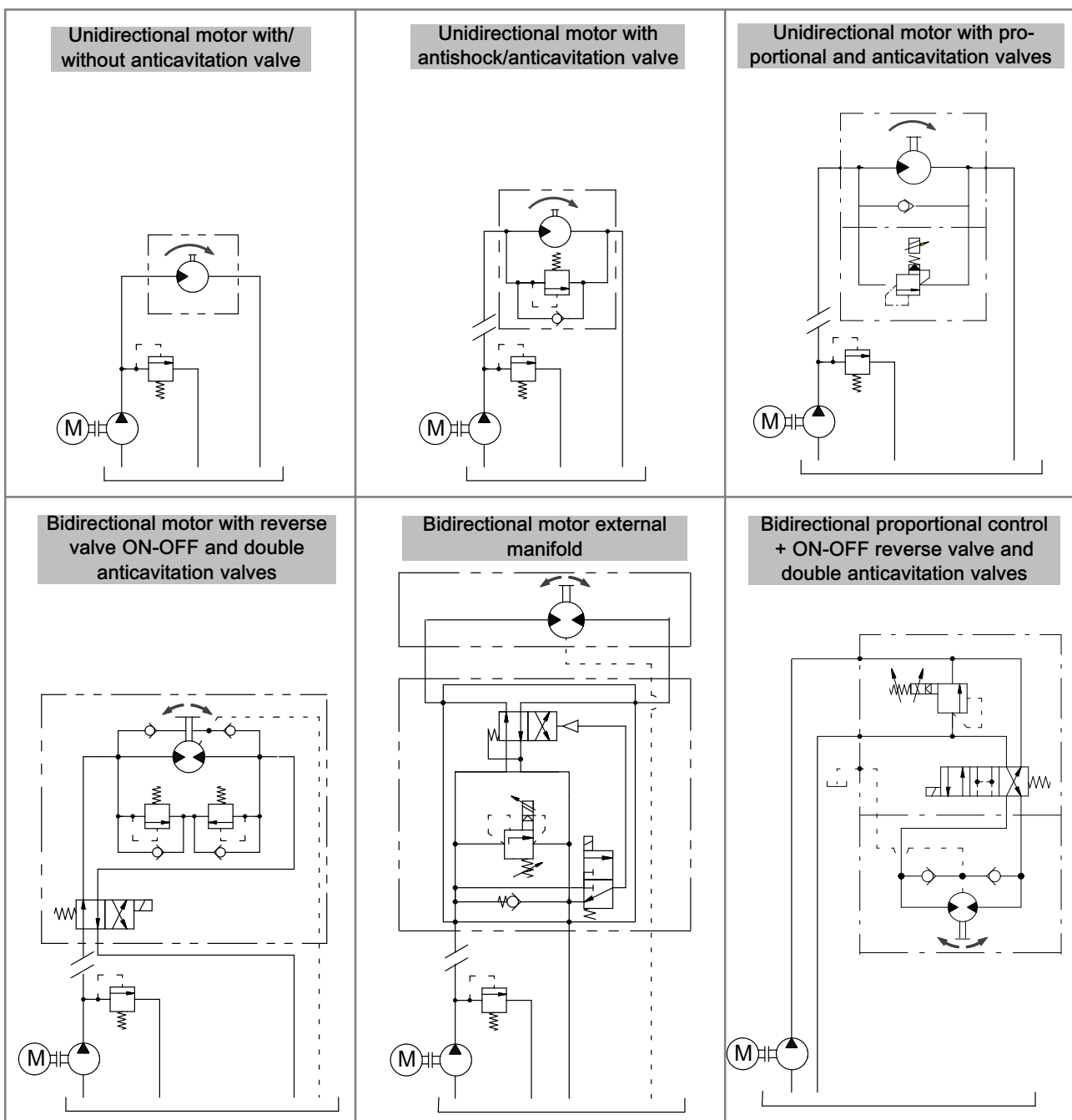

1.12 Directives and standards

- Atex:



Attention: The equipment and protective systems of this catalogue ARE NOT intended for use in potentially explosive atmospheres. Ref: Directive 99/92/EC and Directive 2014/34/EU

- ISO 9001:2015 / ISO 14001:2015

Bucher Hydraulics S.p.A. is certified for research, development and production of directional control valves, power units, gear pumps and motors, electro pumps, cartridge valves and integrated manifolds for hydraulic applications.

1.13 Non-standard symbols used in the text

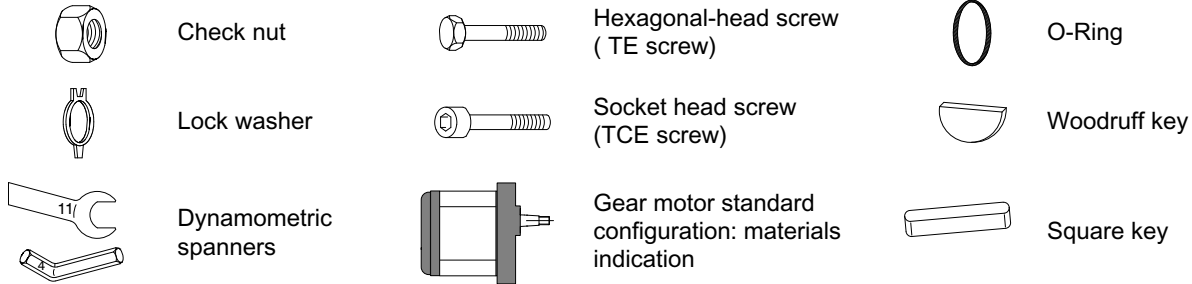

1.14 Gear motor formulas

The following parameters are defined:

V_c = (cm³/r) motor displacement;
n = (r/min) no. of rpm of the outlet shaft;
Q = (l/min) flow rate;
Δp = (bar) P_{IN}-P_{OUT}, operating Δp pressure;
T = (Nm) outlet torque;
N = (kW) outlet power;
η_v = (%) volumetric efficiency;
η_m = (%) mechanical efficiency;
η_t = (%) total efficiency (η_t = η_v · η_m)

1.14.1 Parameter relationships

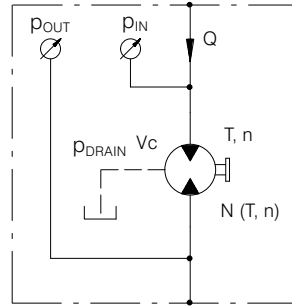
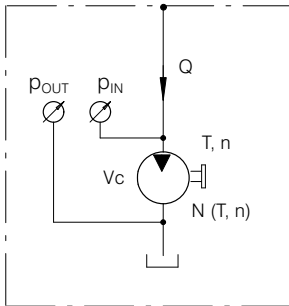
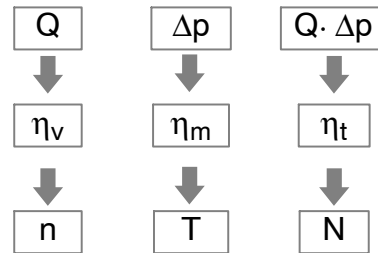

$$Q = \frac{V_c \cdot n}{10 \cdot \eta_v}$$

$$V_c = \frac{10 \cdot Q}{n} \cdot \eta_v$$

$$n = \frac{10 \cdot Q}{V_c} \cdot \eta_v$$

$$\Delta p = \frac{T}{1.592 \cdot V_c \cdot \eta_m} \cdot 10^4$$

$$V_c = \frac{T}{1.592 \cdot \Delta p \cdot \eta_m} \cdot 10^4$$

$$T = 1.592 \cdot V_c \cdot \Delta p \cdot \eta_m \cdot 10^{-4} \quad N = \frac{Q \cdot \Delta p}{6 \cdot 10^4} \cdot \eta_t$$

Example

APM212/11 V_c = 11.1 cm³/r Q_{IN} = 18.5 l/min Δp = 200 bar η_v = 90% η_m = 90%

$$n = \frac{10 \cdot 18.5}{11.1} \cdot 0.90 = 1500 \text{ r/min.}$$

$$\eta_t = 0.90 \cdot 0.90 = 0.81 = 81\%$$

$$N = \frac{18.5 \cdot 200 \cdot 0.81}{6 \cdot 10^4} = 5.0 \text{ kW}$$

$$T = 1.592 \cdot 11.1 \cdot 200 \cdot 0.90 \cdot 10^{-4} = 31.8 \text{ Nm}$$

1.15 Diagrams APM212

Oil viscosity: 37 mm²/s

Oil temperature: 40°C

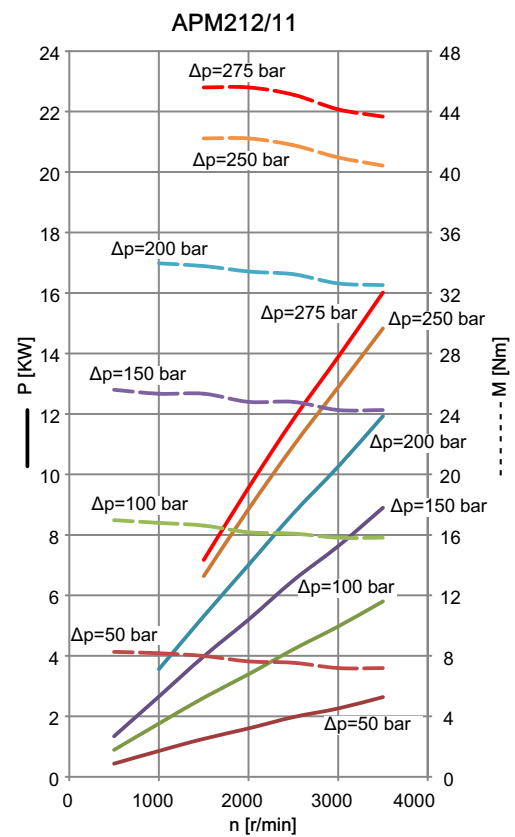
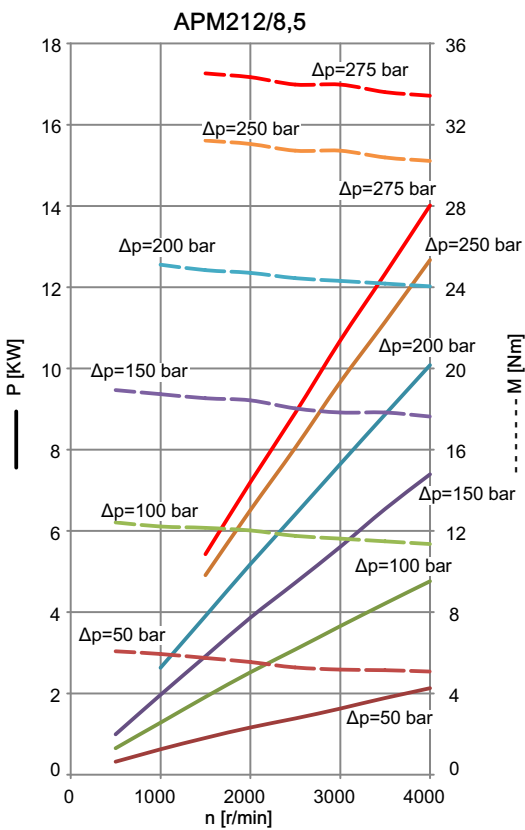
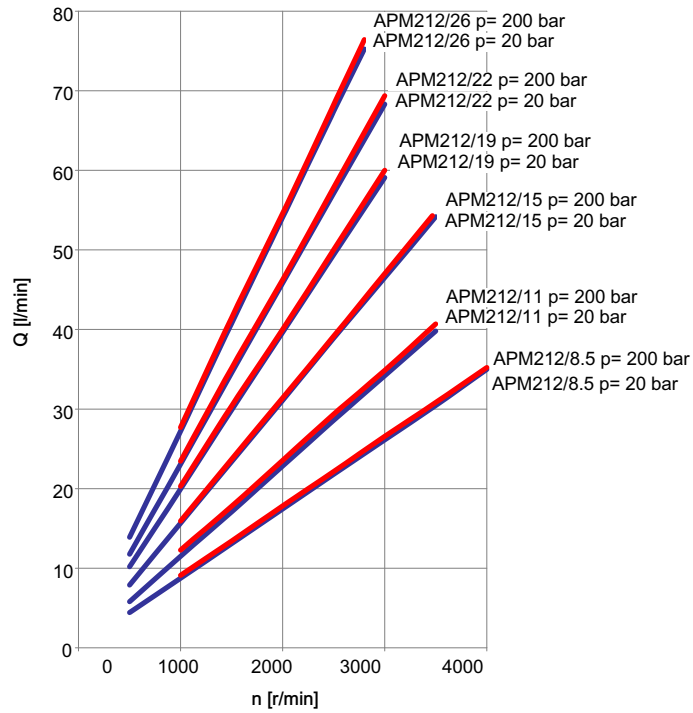

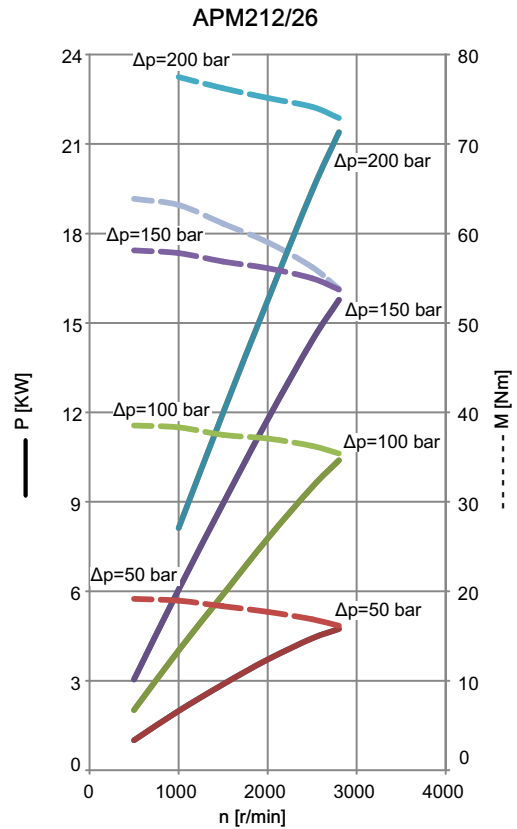
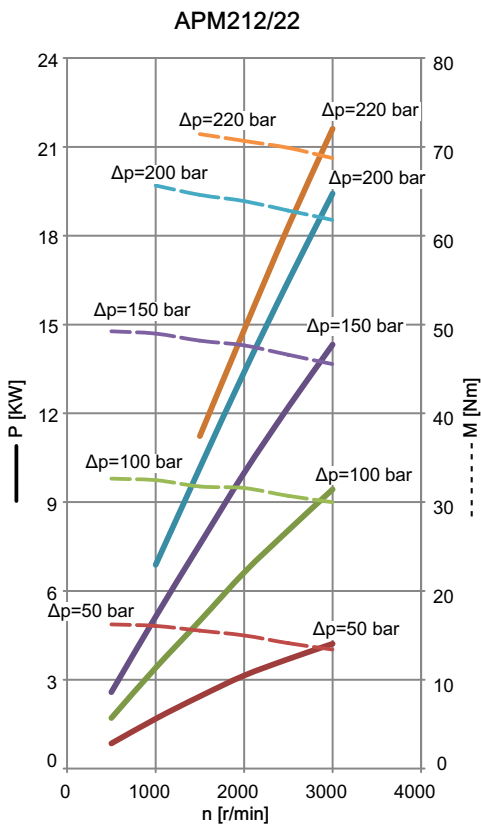
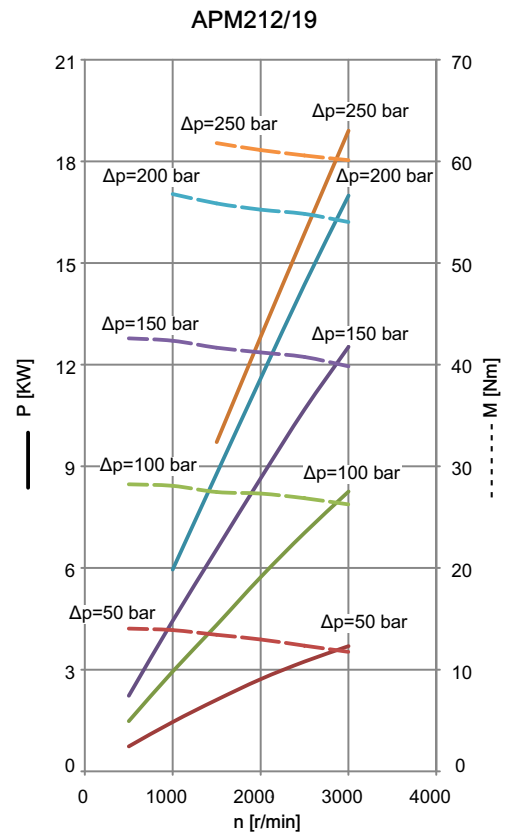
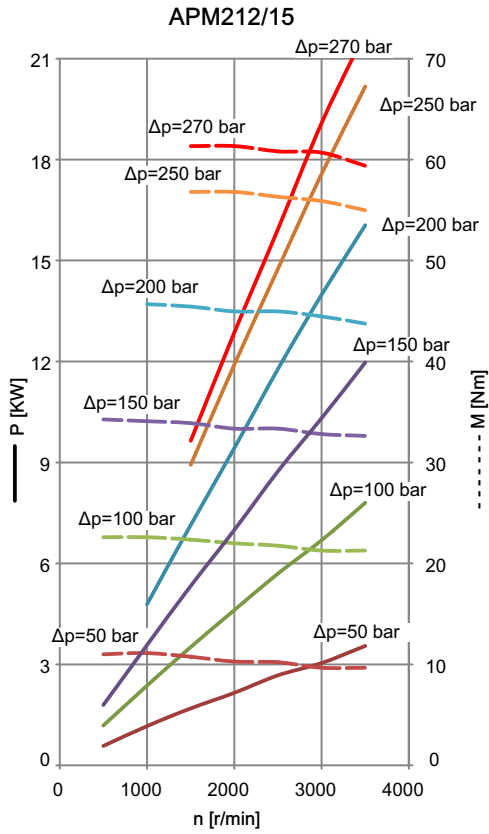

2 Overview standard types (General use)

This motors configuration are considered as "standard".

218	818	225	227	235	245	237
247	887S	880	887S-NPTF	880-NPTF	287S-B	280-B

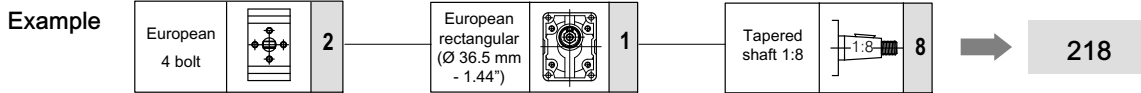

For each series in the next pages are indicated front, rear cover, and seals materials. Ordering these series motors it is enough to indicate motor description, in example APM212/8.5 D 218. For different (other) configurations, or

combination of different features, example port threads, front flange materials etc, it is possible to utilise the description configurator shown at section 3.1

2.1 Standard configuration

Port type			Aluminium front cover type			Drive shaft		
European 4 bolt flanged		2	European rectangular (Ø 36.5 mm - 1.44")		1	Tapered shaft 1:8		8
German 4 bolt flanged		2	German rectangular (Ø 80 mm - 3.15 inches)		2	Tapered shaft 1:5		5
BSPP Threaded ports		8	Through 2 bolts (Ø 50 mm - 1.97")		3	9 teeth external spline B17X14 DIN5482		7
SAE		8	Through 2 bolts (Ø 50 mm - 1.97")		4	9 teeth external spline SAE J 498-9T 16/32 DP		7S
NPTF Threaded ports		8	SAE-A 2 bolts (Ø 82.55 mm - 3.25 inches)		8	Straight keyed Ø 15,85 mm - 0.62 inches		0

Serie	page	Serie	page	Serie	page
218	17	818	18	225	19
227	20	235 - 245	21 22	237 - 247	23 24
887S	25	880	26	887S-NPTF	27
880-NPTF	28	287S-B	29	280-B	30

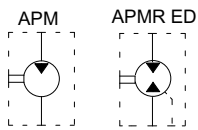

Serie
218

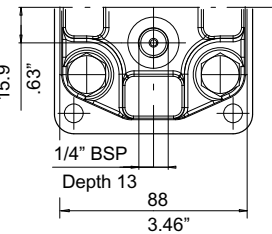
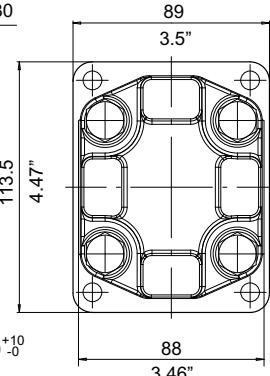
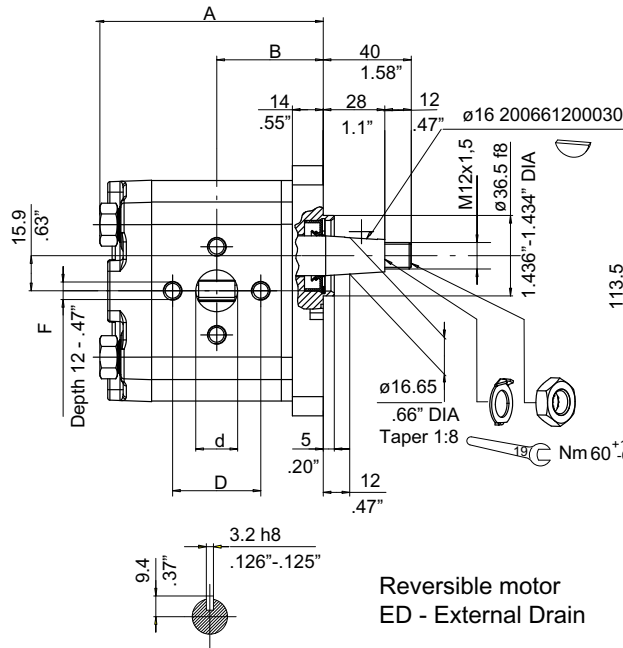
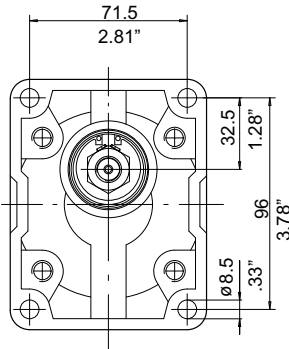
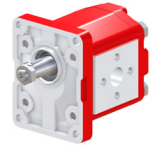

Gear motor material	
Front cover: aluminium	
Body: aluminium	
Back cover: cast iron	
Seals: NBR + HNBR	

Shaft max torque: see section 3.3
Tightening torque: see section 3.5 - 3.6

Reversible motor
ED - External Drain

Type	Displacement cm ³ /rev		Dimensions				Outlet					Inlet					
	APM212	APM212LN	mm	inch	mm	inch	d	inch	D	inch	F	mm	inch	mm	inch	F	mm
8.5	8.4	8.7	95	3.74	46.3	1.82	13.5	.53	30	1.18	M6X1						
11	11.1	11.5	99	3.90	48.3	1.90						13.5	.53	30	1.18	M6X1	
15	15.1	15.7	105	4.13	51.3	2.02											
19	19.2	19.8	111	4.37	54.3	2.14	19	.75	40	1.58	M8X1.25						
22	22.2	23	116	4.57	56.5	2.22						19	.75	40	1.58	M8X1.25	
26	26.2	27.1	122	4.80	59.5	2.34											

Clockwise rotation: D		Counter-clockwise rotation: S		Reversible motor External Drain	
Standard	Low Noise	Standard	Low Noise	Standard	Low Noise
APM212/8.5 D 218	APM212/8.5LN D 218	APM212/8.5 S 218	APM212/8.5LN S 218	APMR212/8.5 ED 218	APMR212/8.5LN ED 218
APM212/11 D 218	APM212/11LN D 218	APM212/11 S 218	APM212/11LN S 218	APMR212/11 ED 218	APMR212/11LN ED 218
APM212/15 D 218	APM212/15LN D 218	APM212/15 S 218	APM212/15LN S 218	APMR212/15 ED 218	APMR212/15LN ED 218
APM212/19 D 218	APM212/19LN D 218	APM212/19 S 218	APM212/19LN S 218	APMR212/19 ED 218	APMR212/19LN ED 218
APM212/22 D 218	APM212/22LN D 218	APM212/22 S 218	APM212/22LN S 218	APMR212/22 ED 218	APMR212/22LN ED 218
APM212/26 D 218	APM212/26LN D 218	APM212/26 S 218	APM212/26LN S 218	APMR212/26 ED 218	APMR212/26LN ED 218

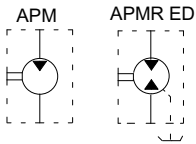

Serie 818

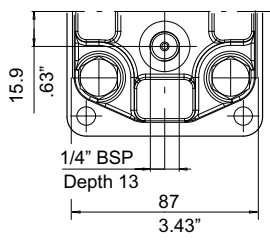
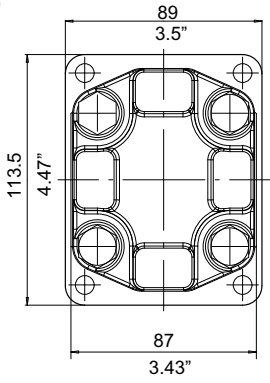
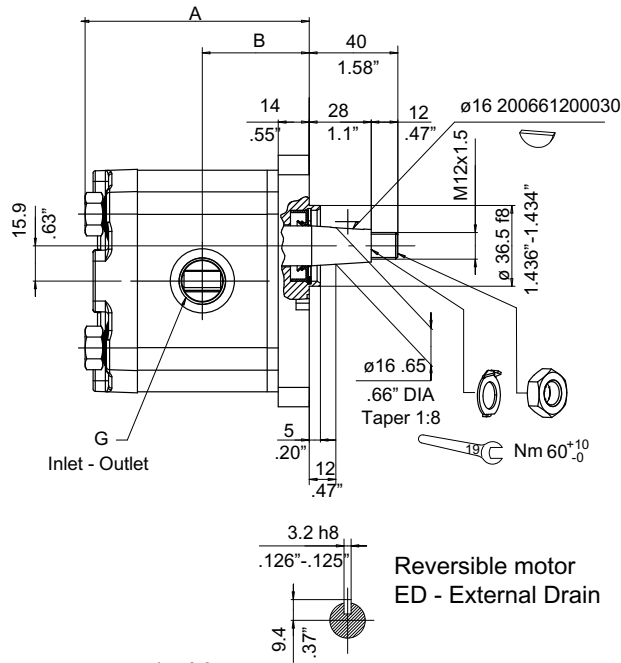
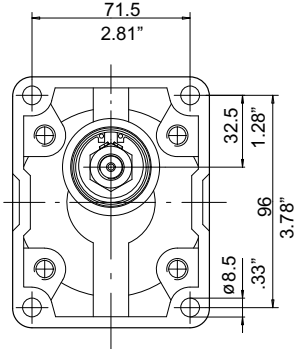

Gear motor material	
Front cover:	aluminium
Body:	aluminium
Back cover:	cast iron
Seals:	NBR + HNBR

Shaft max torque: see section 3.3
Tightening torque: see section 3.5 - 3.6

Type	Displacement cm ³ /rev		Dimensions				Outlet	Inlet
	APM212	APM212LN	A		B		G	G
	mm	inch	mm	inch	mm	inch	BSP	BSP
8.5	8.4	8.7	95	3.74	46.3	1.82	3/8"	3/8"
11	11.1	11.5	99	3.90	48.3	1.90	1/2"	
15	15.1	15.7	105	4.13	51.3	2.02	3/4"	
19	19.2	19.8	111	4.37	54.3	2.14	3/4"	1/2"
22	22.2	23	116	4.57	56.5	2.22		
26	26.2	27.1	122	4.80	59.5	2.34		

Clockwise rotation: D		Counter-clockwise rotation: S		Reversible motor External Drain	
Standard	Low Noise	Standard	Low Noise	Standard	Low Noise
APM212/8.5 D 818	APM212/8.5LN D 818	APM212/8.5 S 818	APM212/8.5LN S 818	APMR212/8.5 ED 818	APMR212/8.5LN ED 818
APM212/11 D 818	APM212/11LN D 818	APM212/11 S 818	APM212/11LN S 818	APMR212/11 ED 818	APMR212/11LN ED 818
APM212/15 D 818	APM212/15LN D 818	APM212/15 S 818	APM212/15LN S 818	APMR212/15 ED 818	APMR212/15LN ED 818
APM212/19 D 818	APM212/19LN D 818	APM212/19 S 818	APM212/19LN S 818	APMR212/19 ED 818	APMR212/19LN ED 818
APM212/22 D 818	APM212/22LN D 818	APM212/22 S 818	APM212/22LN S 818	APMR212/22 ED 818	APMR212/22LN ED 818
APM212/26 D 818	APM212/26LN D 818	APM212/26 S 818	APM212/26LN S 818	APMR212/26 ED 818	APMR212/26LN ED 818

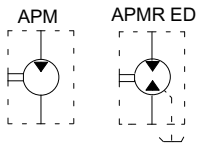

Serie
225

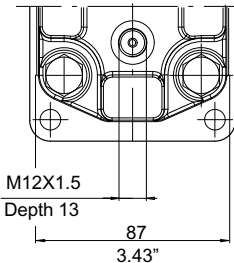
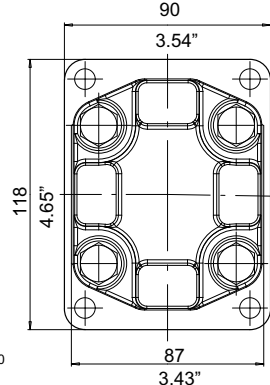
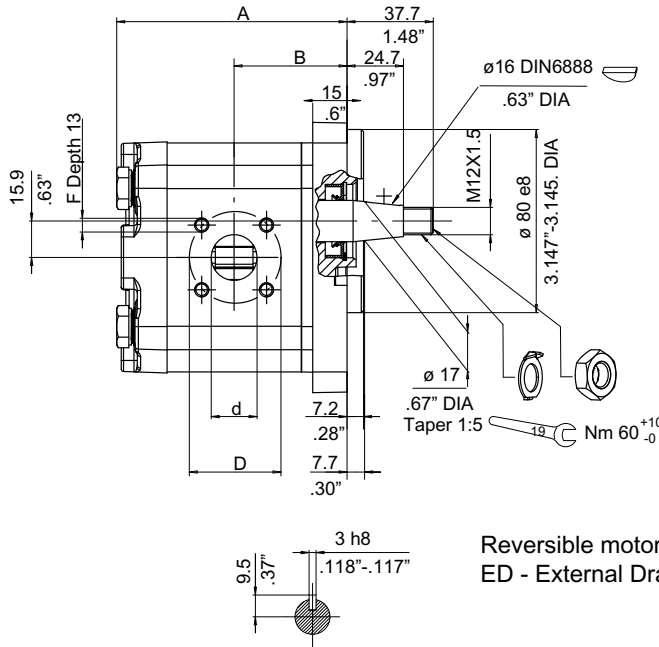
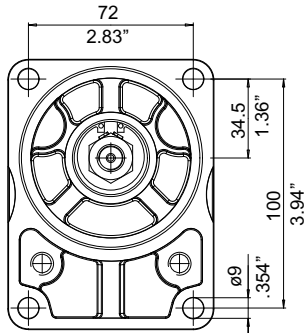

Gear motor material	
Front cover: aluminium	
Body: aluminium	
Back cover: cast iron	
Seals: NBR + HNBR	

Shaft max torque: see section 3.3

Tightening torque: see section 3.5 - 3.6

Type	Displacement cm ³ /rev		Dimensions				Outlet				Inlet					
	APM212	APM212LN	A	B	d	D	F	d	D	F	d	D	F			
	mm	inch	mm	inch	mm	inch	mm	inch	mm	inch	mm	inch	mm	inch		
8.5	8.4	8.7	97	3.82	47.3	1.86	15	.59								
11	11.1	11.5	101	3.98	49.3	1.94	20	.79	40	1.58	M6X1	15	.59	35	1.38	M6X1
15	15.1	15.7	107	4.21	52.3	2.06										
19	19.2	19.8	113	4.45	55.3	2.18										
22	22.2	23	117	4.61	57.5	2.26										
26	26.2	27.1	123	4.84	60.5	2.38										

Clockwise rotation: D		Counter-clockwise rotation: S		Reversible motor External Drain	
Standard	Low Noise	Standard	Low Noise	Standard	Low Noise
APM212/8.5 D 225	APM212/8.5LN D 225	APM212/8.5 S 225	APM212/8.5LN S 225	APMR212/8.5 ED 225	APMR212/8.5LN ED 225
APM212/11 D 225	APM212/11LN D 225	APM212/11 S 225	APM212/11LN S 225	APMR212/11 ED 225	APMR212/11LN ED 225
APM212/15 D 225	APM212/15LN D 225	APM212/15 S 225	APM212/15LN S 225	APMR212/15 ED 225	APMR212/15LN ED 225
APM212/19 D 225	APM212/19LN D 225	APM212/19 S 225	APM212/19LN S 225	APMR212/19 ED 225	APMR212/19LN ED 225
APM212/22 D 225	APM212/22LN D 225	APM212/22 S 225	APM212/22LN S 225	APMR212/22 ED 225	APMR212/22LN ED 225
APM212/26 D 225	APM212/26LN D 225	APM212/26 S 225	APM212/26LN S 225	APMR212/26 ED 225	APMR212/26LN ED 225

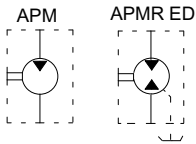

Serie 227

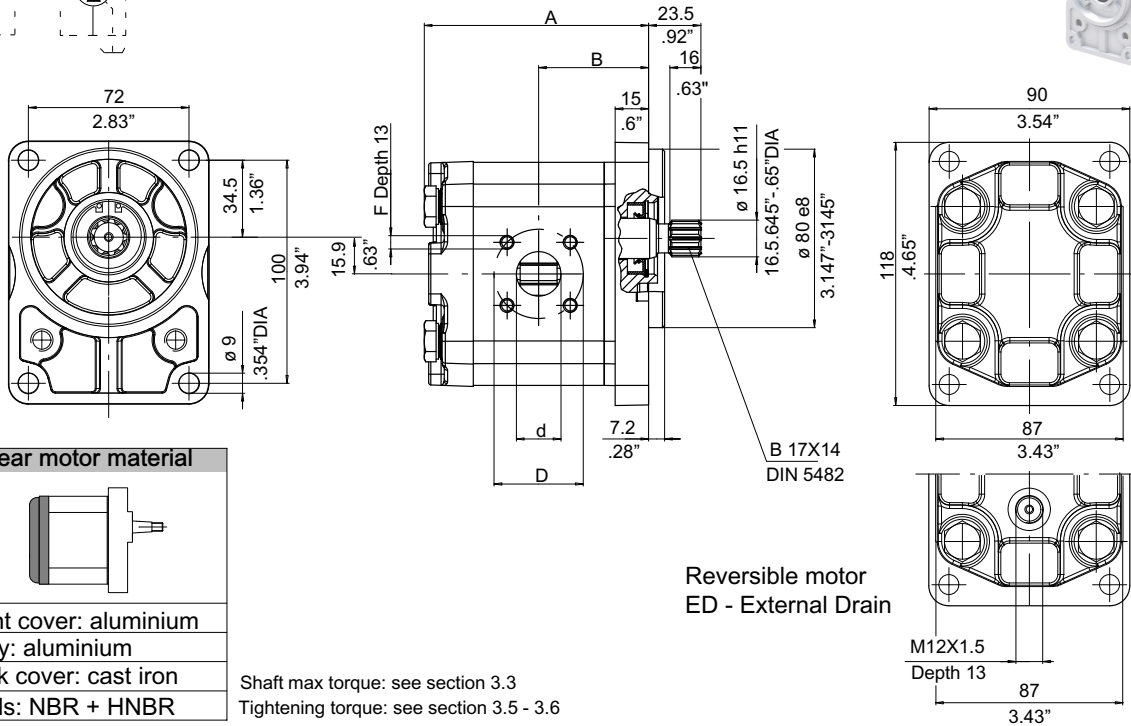

Gear motor material	
Front cover: aluminium	
Body: aluminium	
Back cover: cast iron	
Seals: NBR + HNBR	

Shaft max torque: see section 3.3
Tightening torque: see section 3.5 - 3.6

Reversible motor
ED - External Drain

Type	Displacement cm ³ /rev		Dimensions				Outlet			Inlet							
	APM212	APM212LN	A		B		d		D		F	d		D		F	
			mm	inch	mm	inch	mm	inch	mm	inch	mm	mm	inch	mm	inch	mm	
8.5	8.4	8.7	97	3.82	47.3	1.86	15	.59									
11	11.1	11.5	101	3.98	49.3	1.94	20	.79	40	1.58	M6X1	15	.59	35	1.38	M6X1	
15	15.1	15.7	107	4.21	52.3	2.06											
19	19.2	19.8	113	4.45	55.3	2.18											
22	22.2	23	117	4.61	57.5	2.26											
26	26.2	27.1	123	4.84	60.5	2.38											

Clockwise rotation: D		Counter-clockwise rotation: S		Reversible motor External Drain	
Standard	Low Noise	Standard	Low Noise	Standard	Low Noise
APM212/8.5 D 227	APM212/8.5LN D 227	APM212/8.5 S 227	APM212/8.5LN S 227	APMR212/8.5 ED 227	APMR212/8.5LN ED 227
APM212/11 D 227	APM212/11LN D 227	APM212/11 S 227	APM212/11LN S 227	APMR212/11 ED 227	APMR212/11LN ED 227
APM212/15 D 227	APM212/15LN D 227	APM212/15 S 227	APM212/15LN S 227	APMR212/15 ED 227	APMR212/15LN ED 227
APM212/19 D 227	APM212/19LN D 227	APM212/19 S 227	APM212/19LN S 227	APMR212/19 ED 227	APMR212/19LN ED 227
APM212/22 D 227	APM212/22LN D 227	APM212/22 S 227	APM212/22LN S 227	APMR212/22 ED 227	APMR212/22LN ED 227
APM212/26 D 227	APM212/26LN D 227	APM212/26 S 227	APM212/26LN S 227	APMR212/26 ED 227	APMR212/26LN ED 227

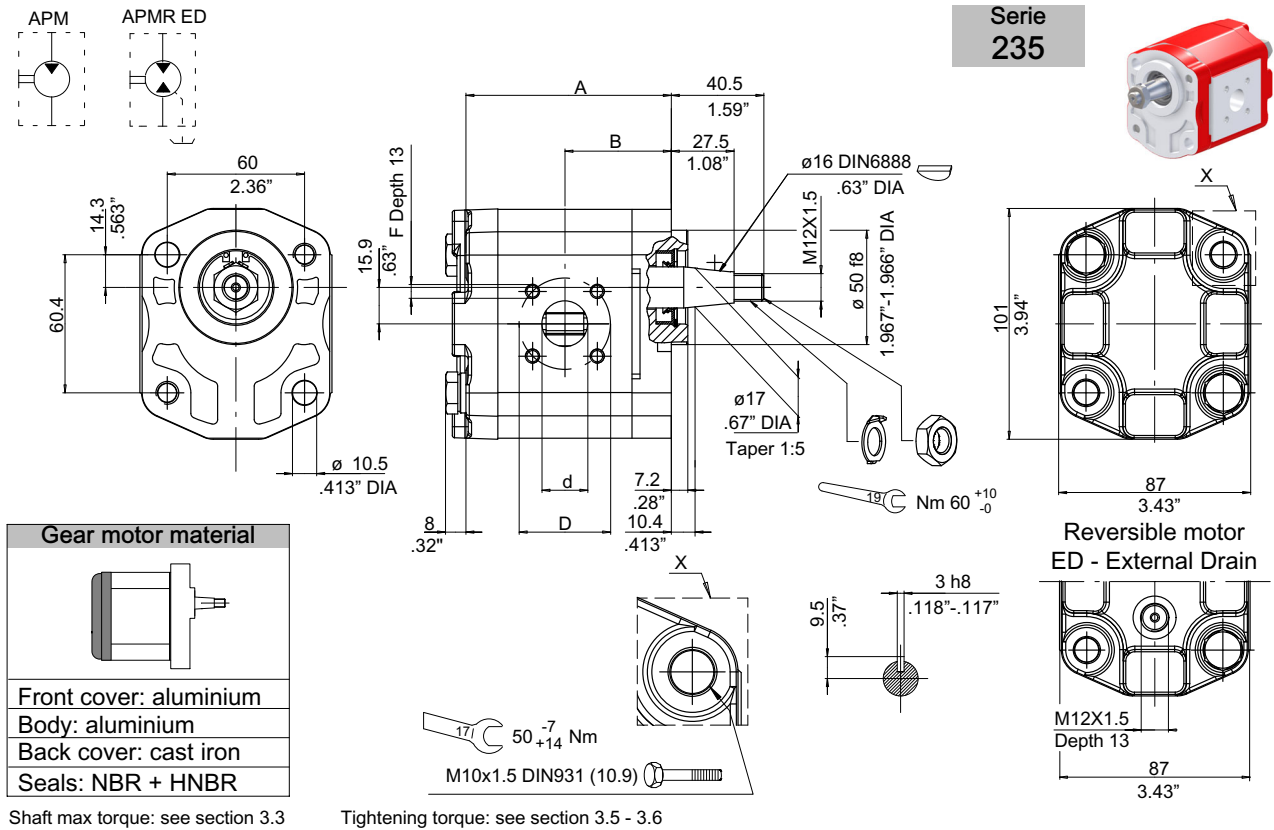

Type	Displacement cm ³ /rev		Dimensions				Outlet				Inlet					
	APM212	APM212LN	A		B		d		D		F	d		D		F
	mm	mm	mm	inch	mm	inch	mm	inch	mm	inch	mm	mm	inch	mm	inch	mm
8.5	8.4	8.7	86	3.39	44.5	1.75	15	.59	40	1.58	M6X1	15	.59	35	1.38	M6X1
11	11.1	11.5	90	3.54	46.5	1.83	20	.79								
15	15.1	15.7	96	3.78	49.5	1.95										
19	19.2	19.8	102	4.02	52.5	2.07										
22	22.2	23	106	4.17	54.8	2.16										
26	26.2	27.1	112	4.41	57.8	2.28										

Clockwise rotation: D		Counter-clockwise rotation: S		Reversible motor External Drain	
Standard	Low Noise	Standard	Low Noise	Standard	Low Noise
APM212/8.5 D 235	APM212/8.5LN D 235	APM212/8.5 S 235	APM212/8.5LN S 235	APMR212/8.5 ED 235	APMR212/8.5LN ED 235
APM212/11 D 235	APM212/11LN D 235	APM212/11 S 235	APM212/11LN S 235	APMR212/11 ED 235	APMR212/11LN ED 235
APM212/15 D 235	APM212/15LN D 235	APM212/15 S 235	APM212/15LN S 235	APMR212/15 ED 235	APMR212/15LN ED 235
APM212/19 D 235	APM212/19LN D 235	APM212/19 S 235	APM212/19LN S 235	APMR212/19 ED 235	APMR212/19LN ED 235
APM212/22 D 235	APM212/22LN D 235	APM212/22 S 235	APM212/22LN S 235	APMR212/22 ED 235	APMR212/22LN ED 235
APM212/26 D 235	APM212/26LN D 235	APM212/26 S 235	APM212/26LN S 235	APMR212/26 ED 235	APMR212/26LN ED 235

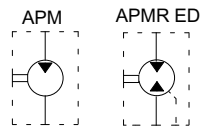

Serie 245

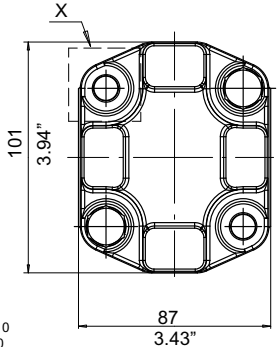
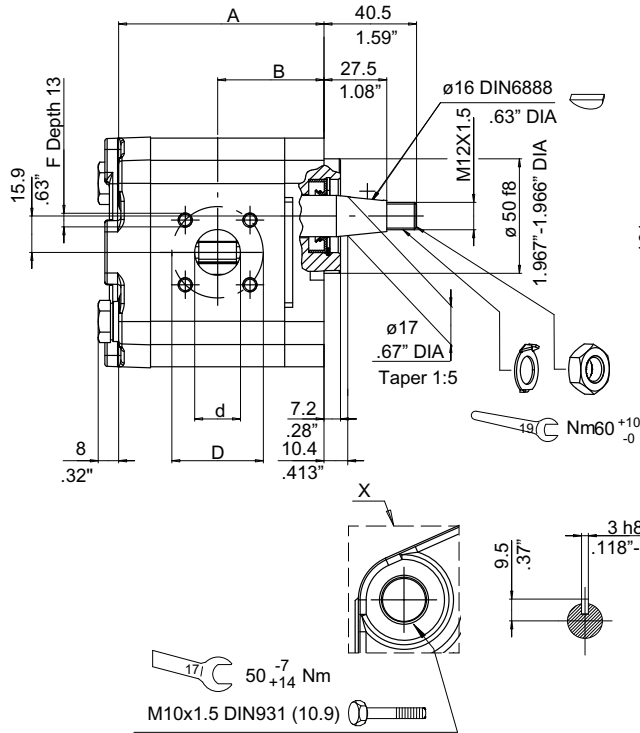
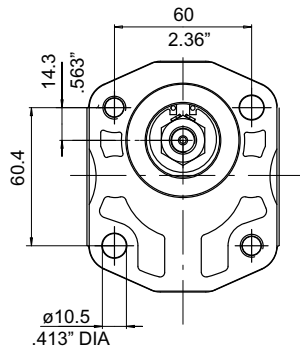
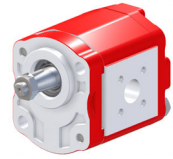

Reversible motor ED - External Drain

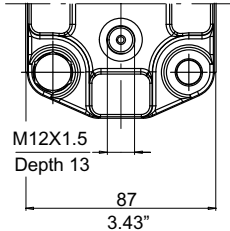

Gear motor material	
Front cover: aluminium	
Body: aluminium	
Back cover: cast iron	
Seals: NBR + HNBR	

Shaft max torque: see section 3.3

Tightening torque: see section 3.5 - 3.6

Type	Displacement cm ³ /rev		Dimensions				Outlet			Inlet						
	APM212	APM212LN	A	B	d	D	F	d	D	F						
	mm	inch	mm	inch	mm	inch	mm	inch	mm	inch	mm					
8.5	8.4	8.7	86	3.39	44.5	1.75	15	.59	40	1.58	M6X1	15	.59	35	1.38	M6X1
11	11.1	11.5	90	3.54	46.5	1.83	20	.79								
15	15.1	15.7	96	3.78	49.5	1.95										
19	19.2	19.8	102	4.02	52.5	2.07										
22	22.2	23	106	4.17	54.8	2.16										
26	26.2	27.1	112	4.41	57.8	2.28										

Clockwise rotation: D		Counter-clockwise rotation: S		Reversible motor External Drain	
Standard	Low Noise	Standard	Low Noise	Standard	Low Noise
APM212/8.5 D 245	APM212/8.5LN D 245	APM212/8.5 S 245	APM212/8.5LN S 245	APMR212/8.5 ED 245	APMR212/8.5LN ED 245
APM212/11 D 245	APM212/11LN D 245	APM212/11 S 245	APM212/11LN S 245	APMR212/11 ED 245	APMR212/11LN ED 245
APM212/15 D 245	APM212/15LN D 245	APM212/15 S 245	APM212/15LN S 245	APMR212/15 ED 245	APMR212/15LN ED 245
APM212/19 D 245	APM212/19LN D 245	APM212/19 S 245	APM212/19LN S 245	APMR212/19 ED 245	APMR212/19LN ED 245
APM212/22 D 245	APM212/22LN D 245	APM212/22 S 245	APM212/22LN S 245	APMR212/22 ED 245	APMR212/22LN ED 245
APM212/26 D 245	APM212/26LN D 245	APM212/26 S 245	APM212/26LN S 245	APMR212/26 ED 245	APMR212/26LN ED 245

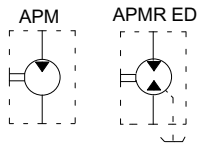

Serie
237

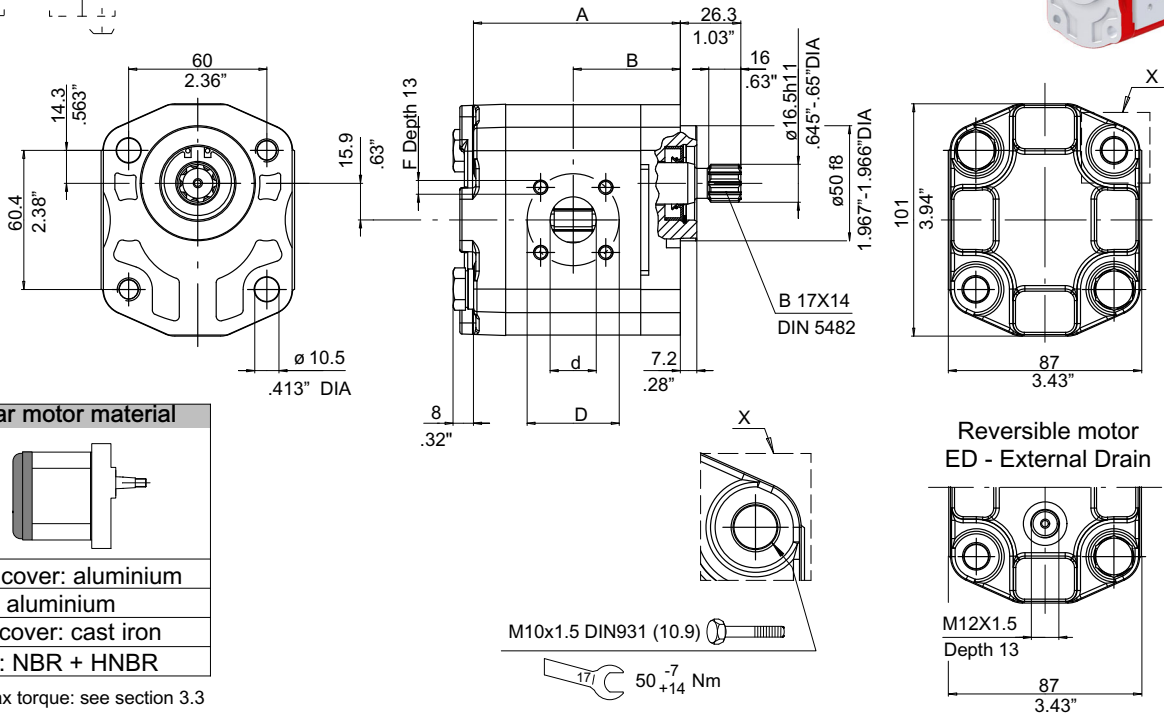

Gear motor material	
Front cover: aluminium	
Body: aluminium	
Back cover: cast iron	
Seals: NBR + HNBR	

Shaft max torque: see section 3.3

Tightening torque: see section 3.5 - 3.6

Type	Displacement cm ³ /rev		Dimensions				Outlet			Inlet						
	APM212	APM212LN	A		B		d		D		F	d		D		F
			mm	inch	mm	inch	mm	inch	mm	inch		mm	inch	mm	inch	
8.5	8.4	8.7	86	3.39	44.5	1.75	20	.79	40	1.58	M6X1	15	.59	35	1.38	M6X1
11	11.1	11.5	90	3.54	46.5	1.83										
15	15.1	15.7	96	3.78	49.5	1.95										
19	19.2	19.8	102	4.02	52.5	2.07										
22	22.2	23	106	4.17	54.8	2.16										
26	26.2	27.1	112	4.41	57.8	2.28										

Clockwise rotation: D		Counter-clockwise rotation: S		Reversible motor External Drain	
Standard	Low Noise	Standard	Low Noise	Standard	Low Noise
APM212/8.5 D 237	APM212/8.5LN D 237	APM212/8.5 S 237	APM212/8.5LN S 237	APMR212/8.5 ED 237	APMR212/8.5LN ED 237
APM212/11 D 237	APM212/11LN D 237	APM212/11 S 237	APM212/11LN S 237	APMR212/11 ED 237	APMR212/11LN ED 237
APM212/15 D 237	APM212/15LN D 237	APM212/15 S 237	APM212/15LN S 237	APMR212/15 ED 237	APMR212/15LN ED 237
APM212/19 D 237	APM212/19LN D 237	APM212/19 S 237	APM212/19LN S 237	APMR212/19 ED 237	APMR212/19LN ED 237
APM212/22 D 237	APM212/22LN D 237	APM212/22 S 237	APM212/22LN S 237	APMR212/22 ED 237	APMR212/22LN ED 237
APM212/26 D 237	APM212/26LN D 237	APM212/26 S 237	APM212/26LN S 237	APMR212/26 ED 237	APMR212/26LN ED 237

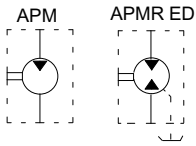

Serie 247

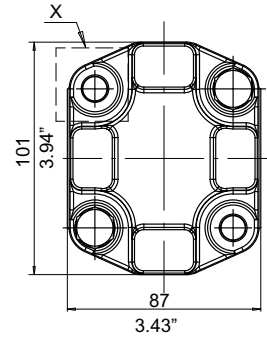
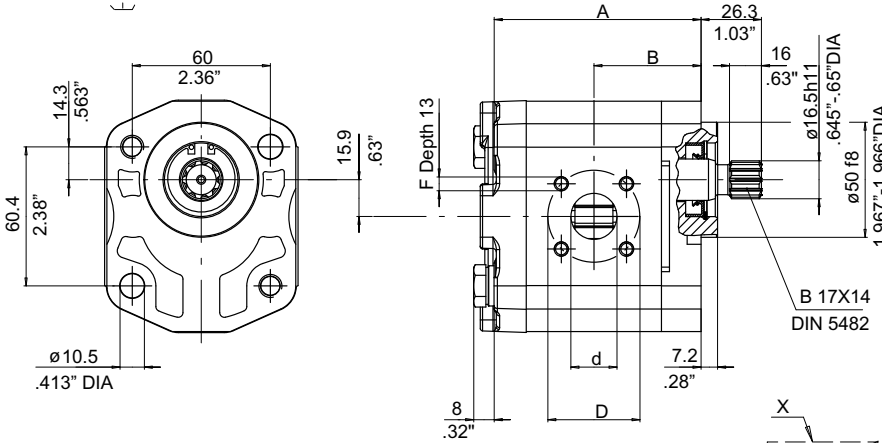
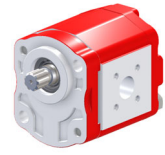

Reversible motor ED - External Drain

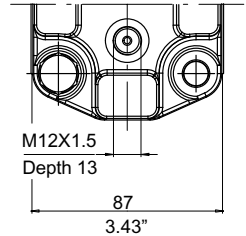

Gear motor material	
	Front cover: aluminium
	Body: aluminium
	Back cover: cast iron
	Seals: NBR + HNBR

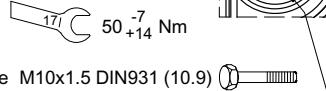

To utilize M10x1.5 DIN931 (10.9)

Shaft max torque: see section 3.3
Tightening torque: see section 3.5 - 3.6

Type	Displacement cm ³ /rev		Dimensions				Outlet			Inlet						
	APM212	APM212LN	A mm	A inch	B mm	B inch	d mm	d inch	D mm	D inch	F mm	d mm	d inch	D mm	D inch	F mm
8.5	8.4	8.7	86	3.39	44.5	1.75	15	.59	40	1.58	M6X1	15	.59	35	1.38	M6X1
11	11.1	11.5	90	3.54	46.5	1.83	20	.79								
15	15.1	15.7	96	3.78	49.5	1.95										
19	19.2	19.8	102	4.02	52.5	2.07										
22	22.2	23	106	4.17	54.8	2.16										
26	26.2	27.1	112	4.41	57.8	2.28										

Clockwise rotation: D		Counter-clockwise rotation: S		Reversible motor External Drain	
Standard	Low Noise	Standard	Low Noise	Standard	Low Noise
APM212/8.5 D 247	APM212/8.5LN D 247	APM212/8.5 S 247	APM212/8.5LN S 247	APMR212/8.5 ED 247	APMR212/8.5LN ED 247
APM212/11 D 247	APM212/11LN D 247	APM212/11 S 247	APM212/11LN S 247	APMR212/11 ED 247	APMR212/11LN ED 247
APM212/15 D 247	APM212/15LN D 247	APM212/15 S 247	APM212/15LN S 247	APMR212/15 ED 247	APMR212/15LN ED 247
APM212/19 D 247	APM212/19LN D 247	APM212/19 S 247	APM212/19LN S 247	APMR212/19 ED 247	APMR212/19LN ED 247
APM212/22 D 247	APM212/22LN D 247	APM212/22 S 247	APM212/22LN S 247	APMR212/22 ED 247	APMR212/22LN ED 247
APM212/26 D 247	APM212/26LN D 247	APM212/26 S 247	APM212/26LN S 247	APMR212/26 ED 247	APMR212/26LN ED 247

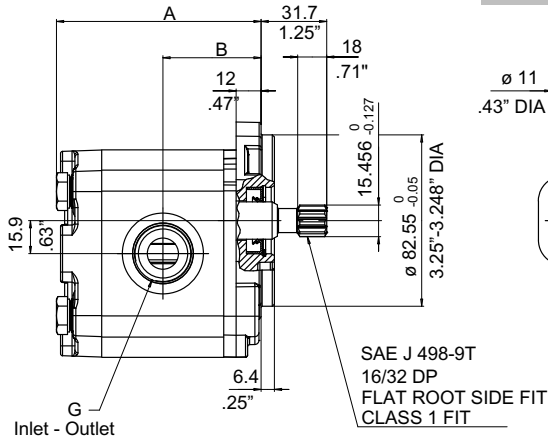
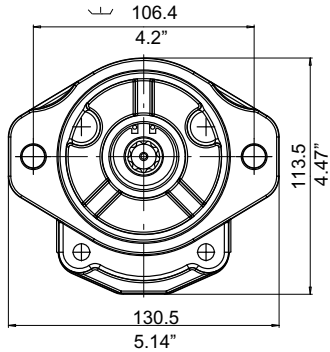
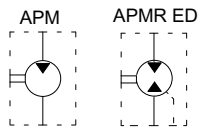

Serie
887S

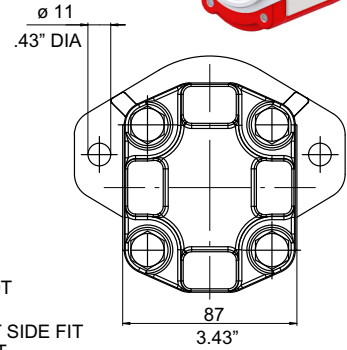

Reversible motor
ED - External Drain

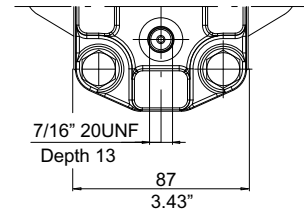

Gear motor material	
Front cover: aluminium	
Body: aluminium	
Back cover: cast iron	
Seals: NBR + HNBR	

Shaft max torque: see section 3.3
Tightening torque: see section 3.5 - 3.6

Type	Displacement cm ³ /rev		Dimensions				Outlet G UNF	Inlet G UNF
	APM212	APM212LN	A		B			
			mm	inch	mm	inch		
8.5	8.4	8.7	94.5	3.72	45.5	1.79	1-1/16" 12 (SAE12)	7/8" 14 (SAE10)
11	11.1	11.5	98.5	3.88	47.5	1.87		
15	15.1	15.7	104.5	4.11	50.5	1.99		
19	19.2	19.8	110.5	4.35	53.5	2.11		
22	22.2	23	115	4.52	55.5	2.18		
26	26.2	27.1	121	4.76	58.5	2.30		

Clockwise rotation: D		Counter-clockwise rotation: S		Reversible motor External Drain	
Standard	Low Noise	Standard	Low Noise	Standard	Low Noise
APM212/8.5 D 887S	APM212/8.5LN D 887S	APM212/8.5 S 887S	APM212/8.5LN S 887S	APMR212/8.5 ED 887S	APMR212/8.5LN ED 887S
APM212/11 D 887S	APM212/11LN D 887S	APM212/11 S 887S	APM212/11LN S 887S	APMR212/11 ED 887S	APMR212/11LN ED 887S
APM212/15 D 887S	APM212/15LN D 887S	APM212/15 S 887S	APM212/15LN S 887S	APMR212/15 ED 887S	APMR212/15LN ED 887S
APM212/19 D 887S	APM212/19LN D 887S	APM212/19 S 887S	APM212/19LN S 887S	APMR212/19 ED 887S	APMR212/19LN ED 887S
APM212/22 D 887S	APM212/22LN D 887S	APM212/22 S 887S	APM212/22LN S 887S	APMR212/22 ED 887S	APMR212/22LN ED 887S
APM212/26 D 887S	APM212/26LN D 887S	APM212/26 S 887S	APM212/26LN S 887S	APMR212/26 ED 887S	APMR212/26LN ED 887S

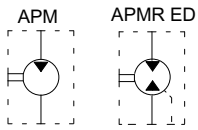

Serie 880

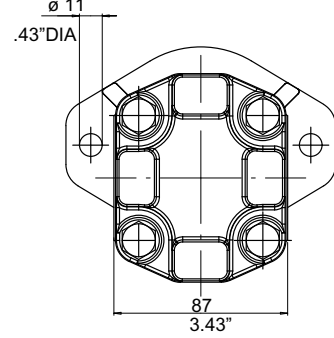
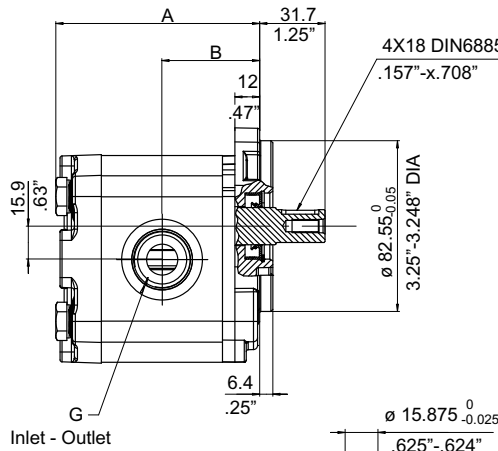
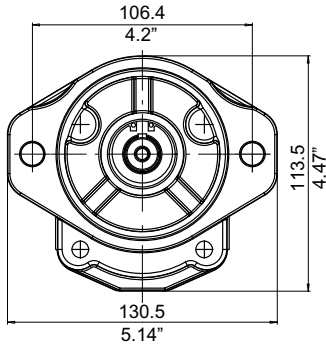

Gear motor material	
Front cover: aluminium	
Body: aluminium	
Back cover: cast iron	
Seals: NBR + HNBR	

Shaft max torque: see section 3.3
Tightening torque: see section 3.5 - 3.6

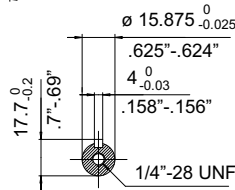

Reversible motor ED - External Drain

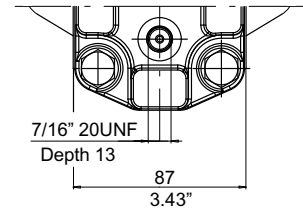

Type	Displacement cm ³ /rev		Dimensions				Outlet G UNF	Inlet G UNF
	APM212	APM212LN	A		B			
			mm	inch	mm	inch		
8.5	8.4	8.7	94.5	3.72	45.5	1.79	1-1/16" 12 SAE12	7/8" 14 SAE10
11	11.1	11.5	98.5	3.88	47.5	1.87		
15	15.1	15.7	104.5	4.11	50.5	1.99		
19	19.2	19.8	110.5	4.35	53.5	2.11		
22	22.2	23	115	4.52	55.5	2.18		
26	26.2	27.1	121	4.76	58.5	2.30		

Clockwise rotation: D		Counter-clockwise rotation: S		Reversible motor External Drain	
Standard	Low Noise	Standard	Low Noise	Standard	Low Noise
APM212/8.5 D 880	APM212/8.5LN D 880	APM212/8.5 S 880	APM212/8.5LN S 880	APMR212/8.5 ED 880	APMR212/8.5LN ED 880
APM212/11 D 880	APM212/11LN D 880	APM212/11 S 880	APM212/11LN S 880	APMR212/11 ED 880	APMR212/11LN ED 880
APM212/15 D 880	APM212/15LN D 880	APM212/15 S 880	APM212/15LN S 880	APMR212/15 ED 880	APMR212/15LN ED 880
APM212/19 D 880	APM212/19LN D 880	APM212/19 S 880	APM212/19LN S 880	APMR212/19 ED 880	APMR212/19LN ED 880
APM212/22 D 880	APM212/22LN D 880	APM212/22 S 880	APM212/22LN S 880	APMR212/22 ED 880	APMR212/22LN ED 880
APM212/26 D 880	APM212/26LN D 880	APM212/26 S 880	APM212/26LN S 880	APMR212/26 ED 880	APMR212/26LN ED 880

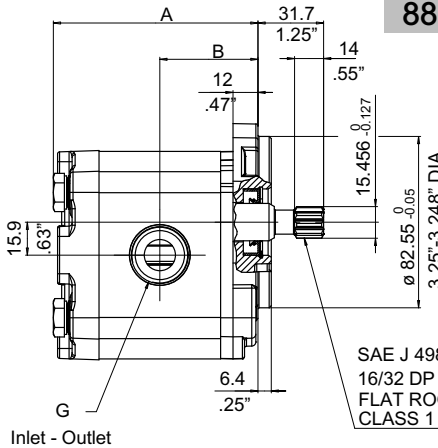
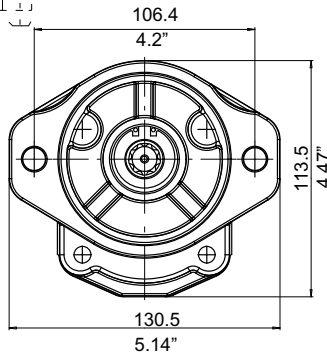
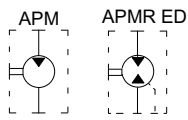

Serie
887S-NPTF

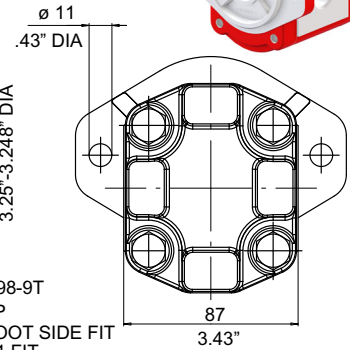

Gear motor material

Front cover: aluminium
Body: aluminium
Back cover: cast iron
Seals: NBR + HNBR

Shaft max torque: see section 3.3
Tightening torque: see section 3.5 - 3.6

Reversible motor
ED - External Drain

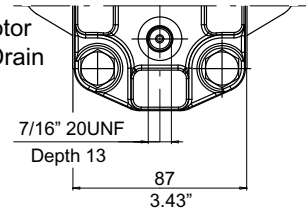

Type	Displacement cm ³ /rev		Dimensions				Outlet G NPTF	Inlet G NPTF
	APM212	APM212LN	A		B			
			mm	inch	mm	inch		
8.5	8.4	8.7	94.5	3.72	45.5	1.79	3/4"	1/2"
11	11.1	11.5	98.5	3.88	47.5	1.87		
15	15.1	15.7	104.5	4.11	50.5	1.99		
19	19.2	19.8	110.5	4.35	53.5	2.11		
22	22.2	23	115	4.52	55.5	2.18		
26	26.2	27.1	121	4.76	58.5	2.30		

Clockwise rotation: D		Counter-clockwise rotation: S		Reversible motor External Drain	
Standard	Low Noise	Standard	Low Noise	Standard	Low Noise
APM212/8.5 D 887S-NPTF	APM212/8.5LN D 887S-NPTF	APM212/8.5 S 887S-NPTF	APM212/8.5LN S 887S-NPTF	APMR212/8.5 ED 887S-NPTF	APMR212/8.5LN ED 887S-NPTF
APM212/11 D 887S-NPTF	APM212/11LN D 887S-NPTF	APM212/11 S 887S-NPTF	APM212/11LN S 887S-NPTF	APMR212/11 ED 887S-NPTF	APMR212/11LN ED 887S-NPTF
APM212/15 D 887S-NPTF	APM212/15LN D 887S-NPTF	APM212/15 S 887S-NPTF	APM212/15LN S 887S-NPTF	APMR212/15 ED 887S-NPTF	APMR212/15LN ED 887S-NPTF
APM212/19 D 887S-NPTF	APM212/19LN D 887S-NPTF	APM212/19 S 887S-NPTF	APM212/19LN S 887S-NPTF	APMR212/19 ED 887S-NPTF	APMR212/19LN ED 887S-NPTF
APM212/22 D 887S-NPTF	APM212/22LN D 887S-NPTF	APM212/22 S 887S-NPTF	APM212/22LN S 887S-NPTF	APMR212/22 ED 887S-NPTF	APMR212/22LN ED 887S-NPTF
APM212/26 D 887S-NPTF	APM212/26LN D 887S-NPTF	APM212/26 S 887S-NPTF	APM212/26LN S 887S-NPTF	APMR212/26 ED 887S-NPTF	APMR212/26LN ED 887S-NPTF

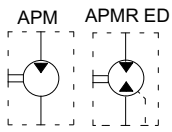

Serie 880-NPTF

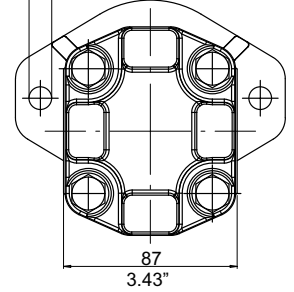
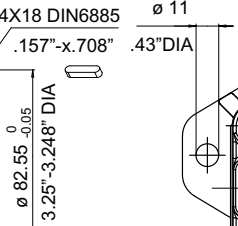
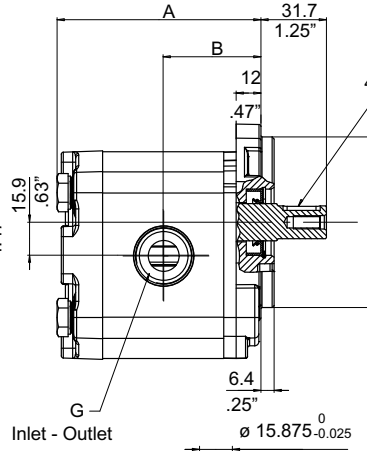
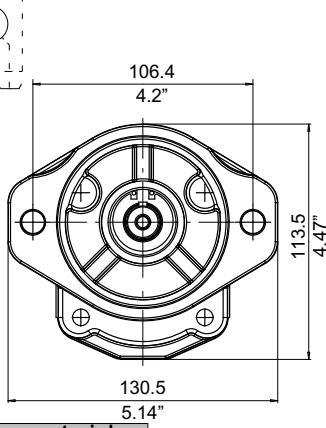
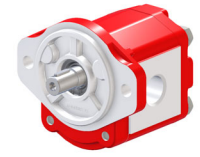

Gear motor material

Front cover: aluminium
 Body: aluminium
 Back cover: cast iron
 Seals: NBR + HNBR

Shaft max torque: see section 3.3

Tightening torque: see section 3.5 - 3.6

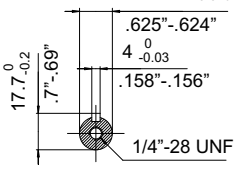

Reversible motor ED - External Drain

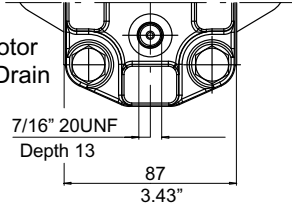

Type	Displacement cm ³ /rev		Dimensions				Outlet G NPTF	Inlet G NPTF
	APM212	APM212LN	mm	inch	mm	inch		
8.5	8.4	8.7	94.5	3.72	45.5	1.79	1/2"	1/2"
11	11.1	11.5	98.5	3.88	47.5	1.87	3/4"	1/2"
15	15.1	15.7	104.5	4.11	50.5	1.99		
19	19.2	19.8	110.5	4.35	53.5	2.11		
22	22.2	23	115	4.52	55.5	2.18		
26	26.2	27.1	121	4.76	58.5	2.30		

Clockwise rotation: D		Counter-clockwise rotation: S		Reversible motor External Drain	
Standard	Low Noise	Standard	Low Noise	Standard	Low Noise
APM212/8.5 D 880-NPTF	APM212/8.5LN D 880-NPTF	APM212/8.5 S 880-NPTF	APM212/8.5LN S 880-NPTF	APMR212/8.5 ED 880-NPTF	APMR212/8.5LN ED 880-NPTF
APM212/11 D 880-NPTF	APM212/11LN D 880-NPTF	APM212/11 S 880-NPTF	APM212/11LN S 880-NPTF	APMR212/11 ED 880-NPTF	APMR212/11LN ED 880-NPTF
APM212/15 D 880-NPTF	APM212/15LN D 880-NPTF	APM212/15 S 880-NPTF	APM212/15LN S 880-NPTF	APMR212/15 ED 880-NPTF	APMR212/15LN ED 880-NPTF
APM212/19 D 880-NPTF	APM212/19LN D 880-NPTF	APM212/19 S 880-NPTF	APM212/19LN S 880-NPTF	APMR212/19 ED 880-NPTF	APMR212/19LN ED 880-NPTF
APM212/22 D 880-NPTF	APM212/22LN D 880-NPTF	APM212/22 S 880-NPTF	APM212/22LN S 880-NPTF	APMR212/22 ED 880-NPTF	APMR212/22LN ED 880-NPTF
APM212/26 D 880-NPTF	APM212/26LN D 880-NPTF	APM212/26 S 880-NPTF	APM212/26LN S 880-NPTF	APMR212/26 ED 880-NPTF	APMR212/26LN ED 880-NPTF

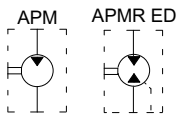

**Serie
287S-B**

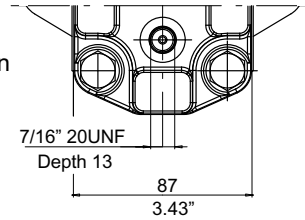
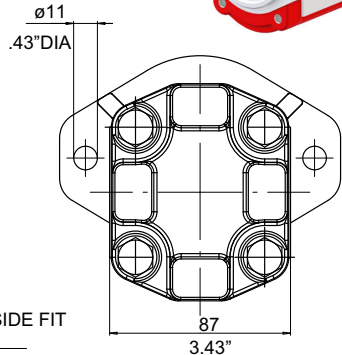
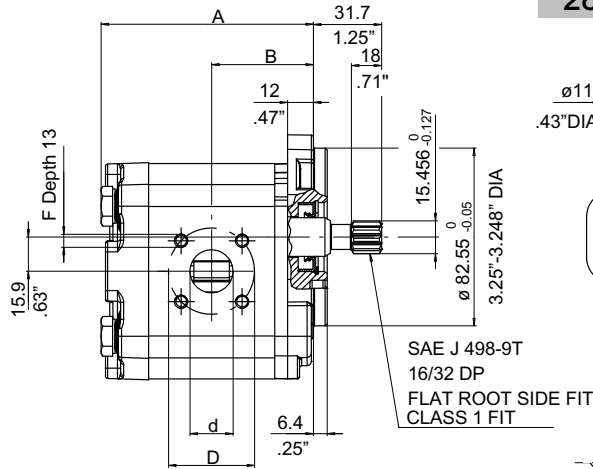
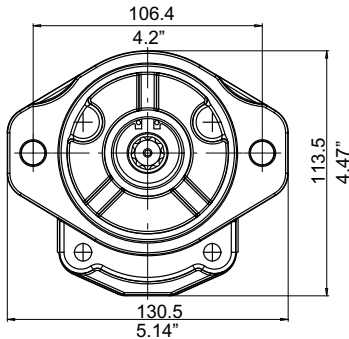
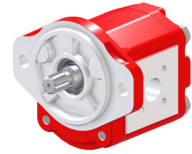

Gear motor material

Front cover: aluminium
Body: aluminium
Back cover: cast iron
Seals: NBR + HNBR

Reversible motor
ED - External Drain

Shaft max torque: see section 3.3
Tightening torque: see section 3.5 - 3.6

Type	Displacement cm ³ /rev		Dimensions				Outlet			Inlet						
	APM212	APM212LN	A	B	d	D	F	d	D	F						
	mm	inch	mm	inch	mm	inch	mm	inch	mm	inch	mm	inch	mm			
8.5	8.4	8.7	94.5	3.72	45.5	1.79	15	.59								
11	11.1	11.5	98.5	3.88	47.5	1.87										
15	15.1	15.7	104.5	4.11	50.5	1.99										
19	19.2	19.8	110.5	4.35	53.5	2.11	20	.79	40	1.58	M6X1	15	.59	35	1.38	M6X1
22	22.2	23	115	4.52	55.5	2.18										
26	26.2	27.1	121	4.76	58.5	2.30										

Clockwise rotation: D		Counter-clockwise rotation: S		Reversible motor External Drain	
Standard	Low Noise	Standard	Low Noise	Standard	Low Noise
APM212/8.5 D 287S-B	APM212/8.5LN D 287S-B	APM212/8.5 S 287S-B	APM212/8.5LN S 287S-B	APMR212/8.5 ED 287S-B	APMR212/8.5LN ED 287S-B
APM212/11 D 287S-B	APM212/11LN D 287S-B	APM212/11 S 287S-B	APM212/11LN S 287S-B	APMR212/11 ED 287S-B	APMR212/11LN ED 287S-B
APM212/15 D287S-B	APM212/15LN D 287S-B	APM212/15 S 287S-B	APM212/15LN S 287S-B	APMR212/15 ED 287S-B	APMR212/15LN ED 287S-B
APM212/19 D 287S-B	APM212/19LN D 287S-B	APM212/19 S 287S-B	APM212/19LN S 287S-B	APMR212/19 ED 287S-B	APMR212/19LN ED 287S-B
APM212/22 D 287S-B	APM212/22LN D 287S-B	APM212/22 S 287S-B	APM212/22LN S 287S-B	APMR212/22 ED 287S-B	APMR212/22LN ED 287S-B
APM212/26 D 287S-B	APM212/26LN D 287S-B	APM212/26 S 287S-B	APM212/26LN S 287S-B	APMR212/26 ED 287S-B	APMR212/26LN ED 287S-B

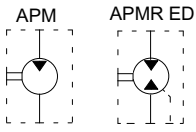

Serie 280-B

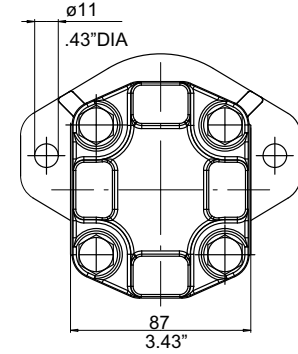
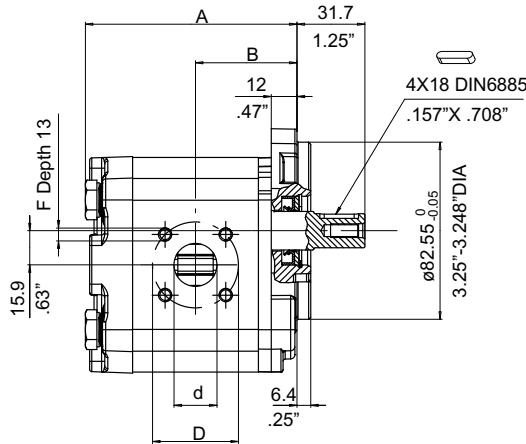
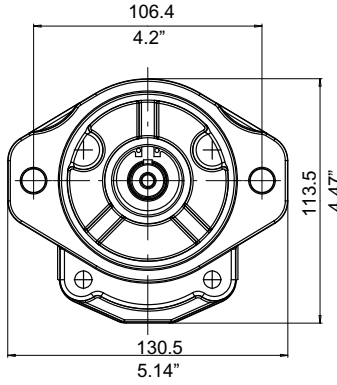

Gear motor material

Front cover: aluminium
 Body: aluminium
 Back cover: cast iron
 Seals: NBR + HNBR

Shaft max torque: see section 3.3
 Tightening torque: see section 3.5 - 3.6

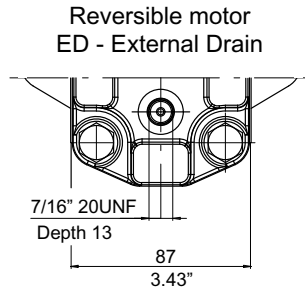
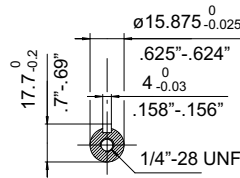

Type	Displacement cm ³ /rev		Dimensions				Outlet			Inlet						
	APM212	APM212LN	A mm	A inch	B mm	B inch	d mm	d inch	D mm	D inch	F mm	d mm	d inch	D mm	D inch	F mm
8.5	8.4	8.7	94.5	3.72	45.5	1.79	15	.59	40	1.58	M6X1	15	.59	35	1.38	M6X1
11	11.1	11.5	98.5	3.88	47.5	1.87	20	.79								
15	15.1	15.7	104.5	4.11	50.5	1.99										
19	19.2	19.8	110.5	4.35	53.5	2.11										
22	22.2	23	115	4.52	55.5	2.18										
26	26.2	27.1	121	4.76	58.5	2.30										

Clockwise rotation: D		Counter-clockwise rotation: S		Reversible motor External Drain	
Standard	Low Noise	Standard	Low Noise	Standard	Low Noise
APM212/8.5 D 280-B	APM212/8.5LN D 280-B	APM212/8.5 S 280-B	APM212/8.5LN S 280-B	APMR212/8.5 ED 280-B	APMR212/8.5LN ED 280-B
APM212/11 D 280-B	APM212/11LN D 280-B	APM212/11 S 280-B	APM212/11LN S 280-B	APMR212/11 ED 280-B	APMR212/11LN ED 280-B
APM212/15 D 280-B	APM212/15LN D 280-B	APM212/15 S 280-B	APM212/15LN S 280-B	APMR212/15 ED 280-B	APMR212/15LN ED 280-B
APM212/19 D 280-B	APM212/19LN D 280-B	APM212/19 S 280-B	APM212/19LN S 280-B	APMR212/19 ED 280-B	APMR212/19LN ED 280-B
APM212/22 D 280-B	APM212/22LN D 280-B	APM212/22 S 280-B	APM212/22LN S 280-B	APMR212/22 ED 280-B	APMR212/22LN ED 280-B
APM212/26 D 280-B	APM212/26LN D 280-B	APM212/26 S 280-B	APM212/26LN S 280-B	APMR212/26 ED 280-B	APMR212/26LN ED 280-B

3 APM212 customised versions (Cooling systems or other applications)

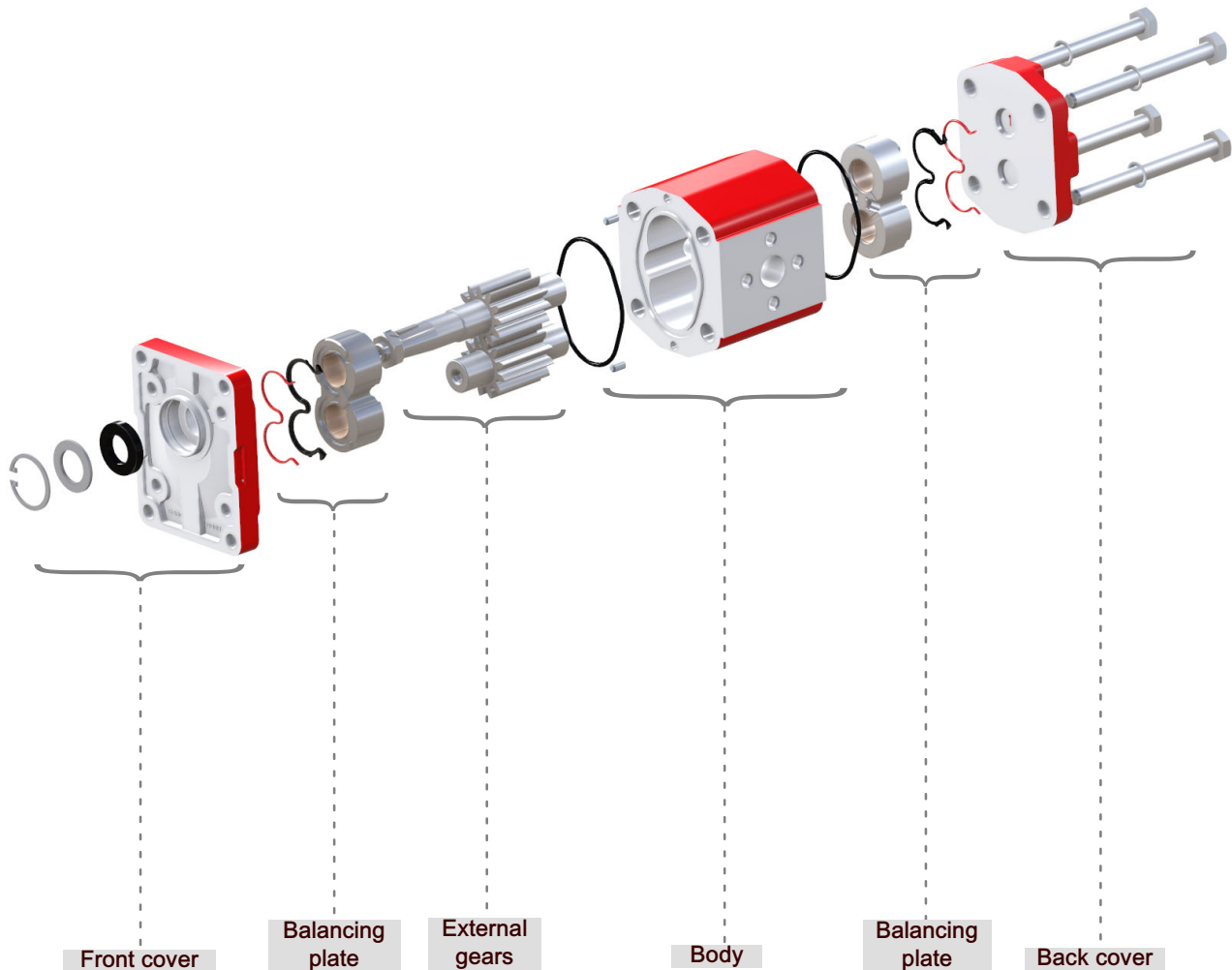







In this section, a single APM212 motor can be configured and customized .

APM212 wide availability of covers, bodies, gears and seals sets provides great flexibility to APM212 motor range and allows several different motor configurations.

In order to simplify the selection of the desired motor combination, a 'configurator form' is available and, by filling it out, it will guide you in the motor creation process.

3.1 Customised versions order example

A	P	M	R	2	1	2	/	8	,	5	L	N	-	S	-	A	6	S	-	1	C	-	G	H	1	-	*	*			
Function APM= single gear motor - unidirectional APMR = single gear motor - reversible																															
Series 212																															
Displacement 8.5= 8.4 cm ³ /rev 11= 11.1 cm ³ /rev 15= 15.1 cm ³ /rev 19= 19.2 cm ³ /rev 22= 22.2 cm ³ /rev 26= 26.2 cm ³ /rev																															
Version Omitted if 12 teeth standard LN= 12 teeth Low Noise version																															
Rotation S = left-hand rotation D = Right-hand rotation Omitted if reversible version																															
Shaft end code see section 3.3																															
Shaft seal material type code see section 3.4.1																															
Front cover series/material with/without bearing code see section 3.4.2																															
Type of ports code see section 3.5																															
Inlet/outlet port size code combination see section 3.5																															
Back cover type see section 3.6																															
BHRE section : Version - Progressive number (omitted)																															

3.2 Single motor dimensions

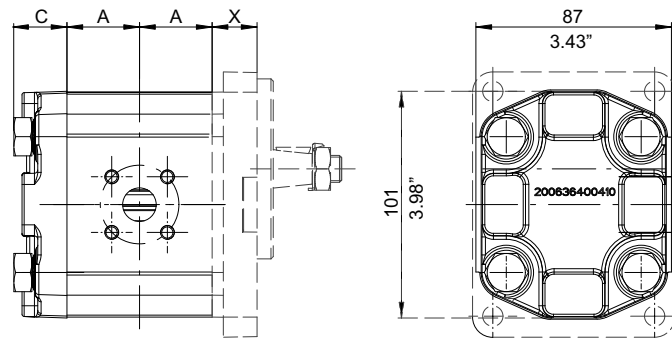

motor size	A		C*	
	mm	inches	mm	inches
APM212/8.5	27.3	1.08	28	1.10
APM212/11	29.3	1.54		
APM212/15	32.3	1.27		
APM212/19	35.3	1.39		
APM212/22	37.6	1.48		
APM212/26	40.6	1.60		

C*: dimensions with standard cast iron back cover with tie rod + nut.
For other back covers dimension see section 3.6.

3.2.1 Front cover dimensions

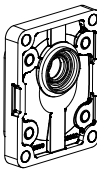
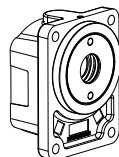
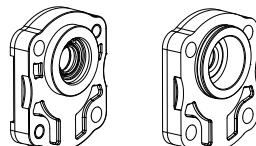
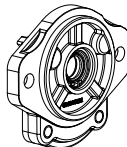
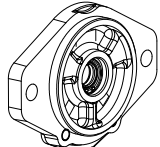
Front cover type	x		Front cover type	x	
	mm	inches		mm	inches
German rectangular 	20	0.79	European rectangular 	19	0.75
Bearing support German version 	48.5	1.91	Through 2 bolts 	17.2	0.68
SAE-A 2 bolts 	18	0.71	SAE-B 2 bolts 	18.2	0.72

3.3 Shaft end code

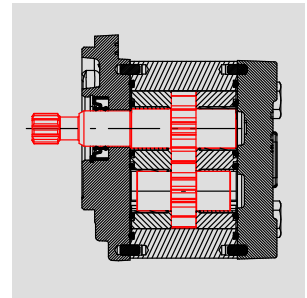
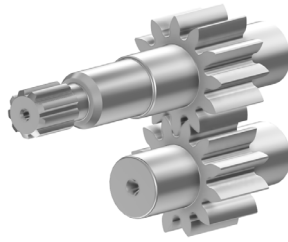

A P M 2 1 2 / 8 , 5 - S - A 6 S - 1 C - G H

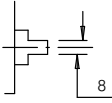
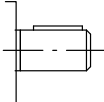
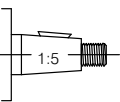
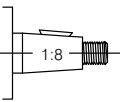
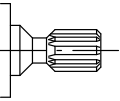
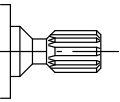
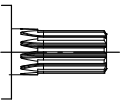
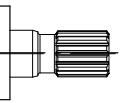
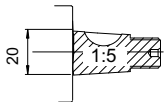
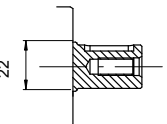
Shaft end shape	Shaft end ordering code	Max torque
	Tang drive 8 mm - 0.32 inches M	T max = 65 Nm
	Straight keyed Ø 15,85 mm - 0.62 inches S	T max = 65 Nm
	Tapered shaft 1:5 G	T max = 135 Nm
	Tapered shaft 1:8 E	T max = 135 Nm
	9 Teeth external spline B17X14 DIN5482 D	T max = 110 Nm
	9 teeth external spline SAE J 498-9T 16/32 DP A	T max = 90 Nm
	11 teeth external spline SAE J 498-11T 16/32 DP T	T max = 140 Nm
	13 teeth external spline SAE J 498-13T 16/32 DP B	T max = 270 Nm
	Bearing application 1:5 see section 3.4.3	T max = 100 Nm
	Straight 22 mm - 0.87 inches see section 3.4.3	T max = 100 Nm

3.4 Front cover

3.4.1 Shaft seal material



A P M 2 1 2 / 8 , 5 - S - A 6 S - 1 C - G H



Shaft seal Type/material	Ordering code
Shaft seal motor NBR	5
Shaft seal motor HNBR (standard)	6
FPM (VITON)	7
High back pressure shaft seal (reduced life see note 1.10)	8

3.4.2 Front cover type

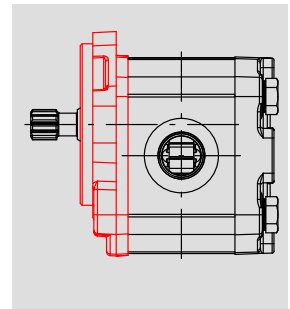

A P M 2 1 2 / 8 , 5 - S - A 6 S - 1 C - G H

Type	General use						Cooling system	
	Alluminium		Cast iron		Cast iron + bearing		Cast iron + dust protection	
	Shape	Ordering code	Shape	Ordering code	Shape	Ordering code	Shape	Ordering code
German rectangular (Ø 80 mm - 3.15 inches)		A		B		C		F
European rectangular (Ø 36.5 mm - 1.44")		D		E		*		K
Through 2 bolts (Ø 50 mm - 1.97")		G		H		*		I
Through 2 bolts (Ø 50 mm - 1.97")		L		M		*		N
Through 2 bolts (Ø 52 mm - 2.05")		O		P		*		
SAE-A 2 bolts (Ø 82.55 mm - 3.25 inches)		R		S		*		Q
SAE-B 2 bolts (Ø 101,6 mm - 4 inches)				V		*		*

Aluminium and cast iron front cover dimensions: see from page 16 to 30 and 33.

* Please consult Bucher Hydraulics

3.4.3 Front bearing application

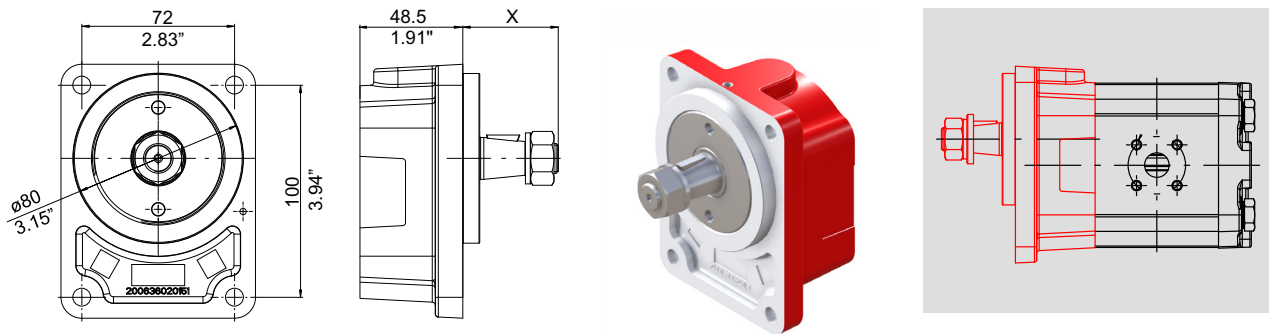

A P M 2 1 2 / 8 , 5 - S - P 1 - 1 C - G H

	+		+	Shaft seal material: HNBR (Standard)	=	P1 T max = 100 Nm
	+	X = 45 mm (1.77 inches)	+	High pressure seal (Reduced life component: see note on section 1.10)	=	P2 T max = 80 Nm
	+		+	Shaft seal material: HNBR (Standard)	=	C1 T max = 100 Nm
	+	Straight 22 mm - 0.87 inches X = 48.5 mm (1.91 inches)	+	High pressure seal (Reduced life component: see note on section 1.10)	=	C2 T max = 80 Nm

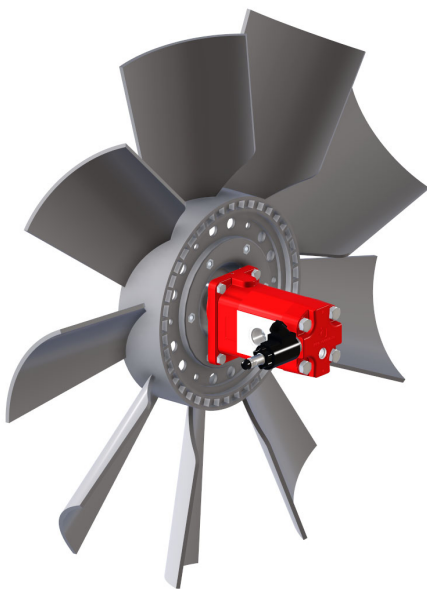

Maximum Axial force admitted with radial load lesser than 100 N

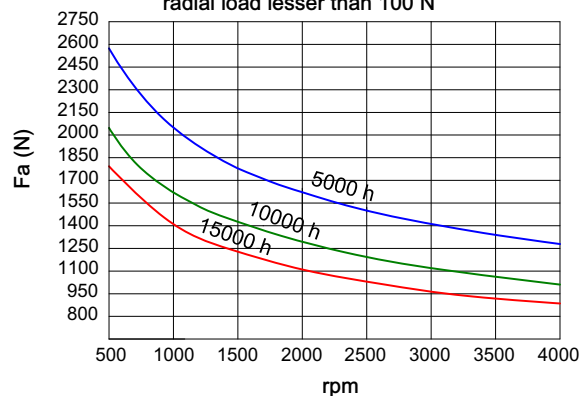

See section 1.9.2

3.5 Body

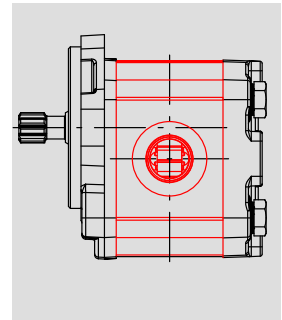
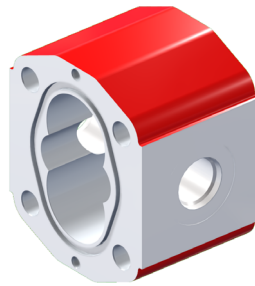

A P M 2 1 2 / 8 , 5 - S - A 6 S - 1 C - G H

Port type	Ordering code	Displacement	Dimension (mm - inch)		Ordering code	
			Outlet	Inlet		
	without	0	All			
	metric	1	8.5	On demand	A	
			11-15		B	
			19-22-26		C	
	BSPP threaded ports	4	8.5	3/8"	3/8"	A
			11-15	1/2"	3/8"	B
			19-22-26	3/4"	1/2"	C

At pressure P1 > 210 bar limited service life

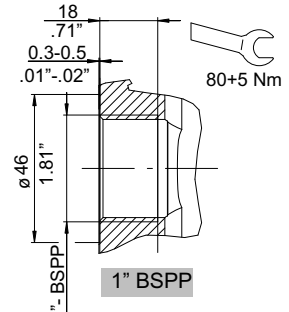
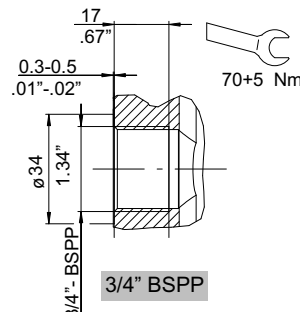
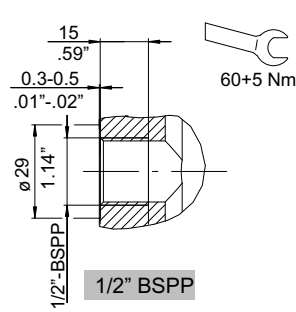
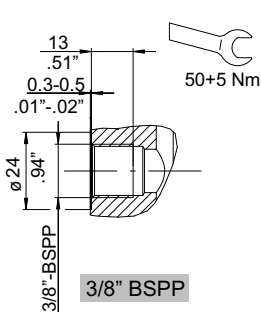

Port type	Ordering code	Displacement	Dimension (mm - inch)		Ordering code
			Outlet	Inlet	
 SAE threaded ports	8	all	1-1/16 12UNF (SAE12)	7/8" 14UNF (SAE10)	A
		8.5	3/4" 16UNF (SAE8)	3/4" 16UNF (SAE8)	B

At pressure P1 > 210 bar limited service life

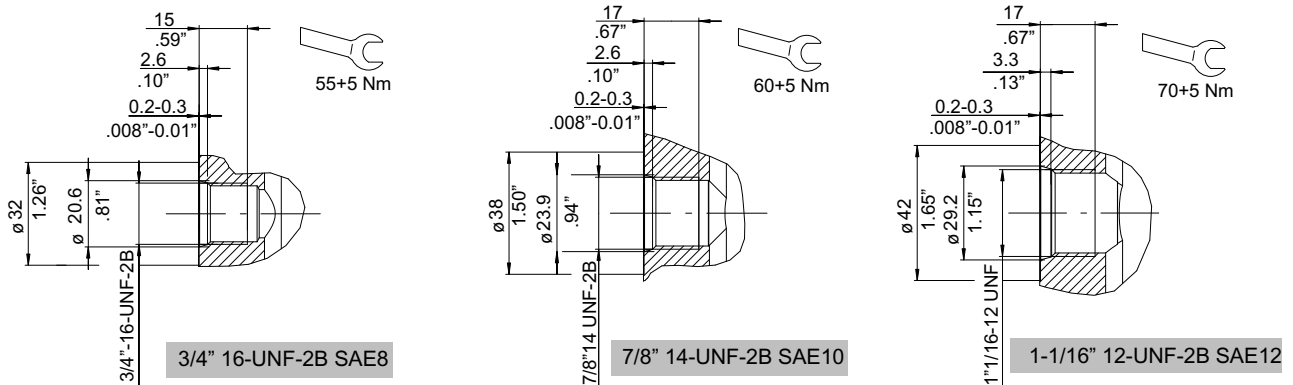

 NFTP	6	8.5	1/2"	1/2"	A
		11-15-19-22-26	3/4"	1/2"	B

At pressure P1 > 210 bar limited service life

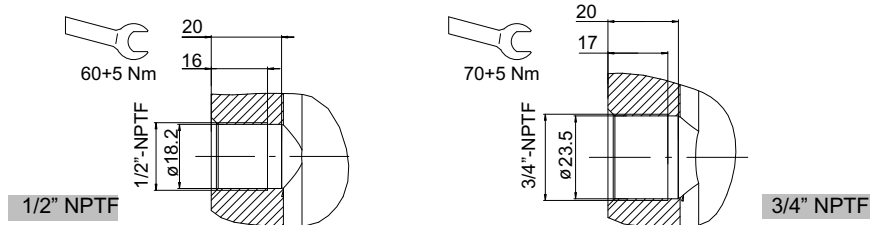

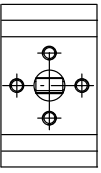
 European 4 bolt	3	8.5	13.5 - .53 (d) 30 - 1.18 (D) M6 (F)	13.5 - .53 (d) 30 - 1.18 (D) M6 (F)	A
		11-15	19 - .75 (d) 40 - 1.58 (D) M8 (F)	13.5 - .53 (d) 30 - 1.18 (D) M6 (F)	B
		19-22-26	19 - .75 (d) 40 - 1.58 (D) M8 (F)	19 - .75 (d) 40 - 1.58 (D) M8 (F)	C

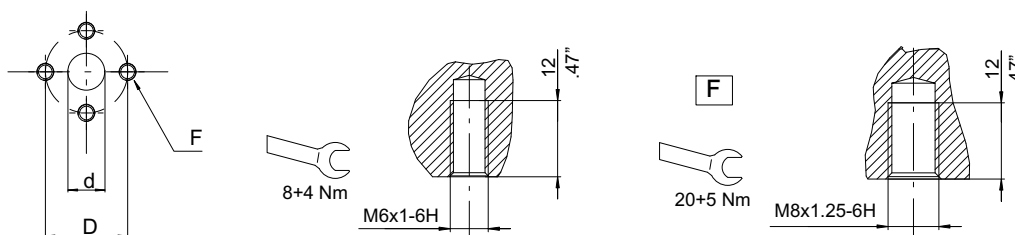

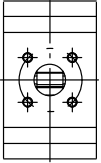
Type	Ordering code	Displacement	Dimension (mm - inch)		Ordering code
			Outlet	Inlet	
 German 4 bolt flanged	2	8.5	15 - .59 (d) 40 - 1.58 (D) M6 (F)	15 - .59 (d) 35 - 1.38 (D) M6 (F) 287-S SAEB: M6 (F)	A
		11-15-19-22-26	20 - .79 (d) 40 - 1.58 (D) M6 (F)		B
		19-22-26 (287-S SAEB)	24 - .95 (d) 55 - 2.17 (D) M8 (F) (287-S SAEB)		C

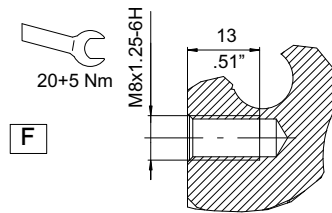
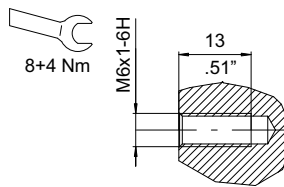
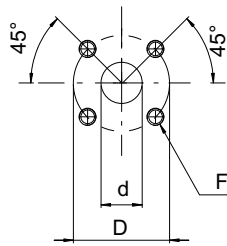

Other ports	9	If the requested port type is not included, please indicate number "9" and specify the details in the request	
-------------	---	---	--

3.5.1 Body seals material: HNBR (standard)

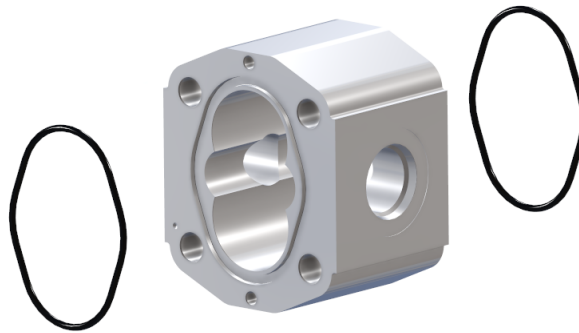

3.6 Back covers

3.6.1 Standard back covers

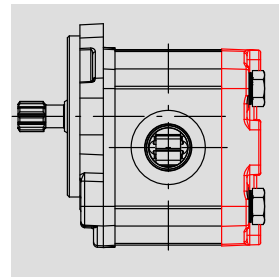
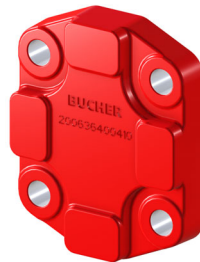

3.6.1.1 Cast iron back cover - Unidirectional motor

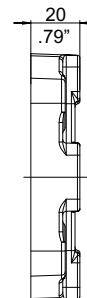
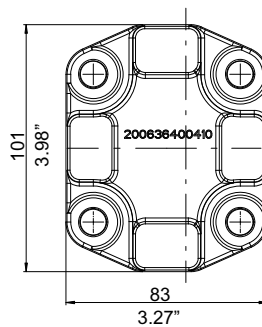
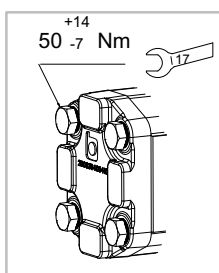

A	P	M	2	1	2	/	8	,	5	-	S	-	A	6	S	-	1	C	-	G	H				
---	---	---	---	---	---	---	---	---	---	---	---	---	---	---	---	---	---	---	---	---	---	--	--	--	--

Type	Ordering code
Back cover, standard version, cast iron material	GH

3.6.1.2 Cast iron back cover with drain port - Standard version for bidirectional motor

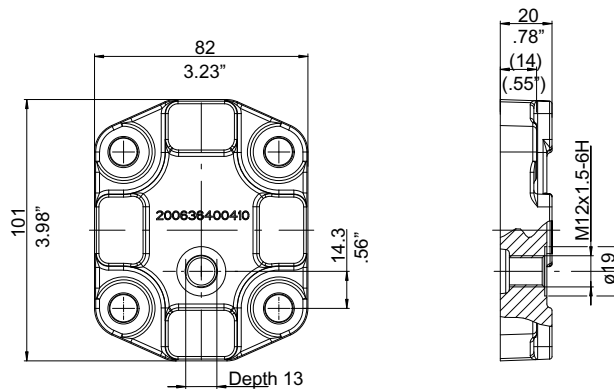

A	P	M	R	2	1	2	/	8	,	5	-	A	6	S	-	1	C	-	G	1				
---	---	---	---	---	---	---	---	---	---	---	---	---	---	---	---	---	---	---	---	---	--	--	--	--

Type	Thread	Tightening torque	Ordering code
Back cover with external drain line, cast iron material for reversible motor	1/4" BSP	30 ⁻⁶ ₊₇ Nm	G1 (standard)
	SAE4	20 ⁻⁵ ₊₅ Nm	G2
	M12x1.5	30 ⁻⁶ ₊₇ Nm	G3

3.7 Valves and circuits

3.7.1 Anticavitation valves DN 3,5 mm integrated inside unidirectional motor

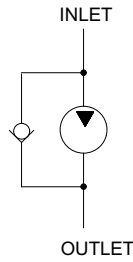

A	P	M	2	1	2	/	8	,	5	-	D	-	A	6	S	-	1	C	-	G	H	+	C				
---	---	---	---	---	---	---	---	---	---	---	---	---	---	---	---	---	---	---	---	---	---	---	---	--	--	--	--

3.7.2 Anticavitation valves DN 3,5 mm integrated inside bidirectional motor used in only one direction

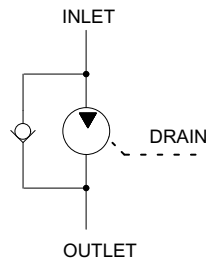

A	P	M	R	2	1	2	/	8	,	5	-	D	-	A	6	S	-	1	C	-	G	1	+	C			
---	---	---	---	---	---	---	---	---	---	---	---	---	---	---	---	---	---	---	---	---	---	---	---	---	--	--	--

3.7.3 Anticavitation valve assembled inside cast iron back cover

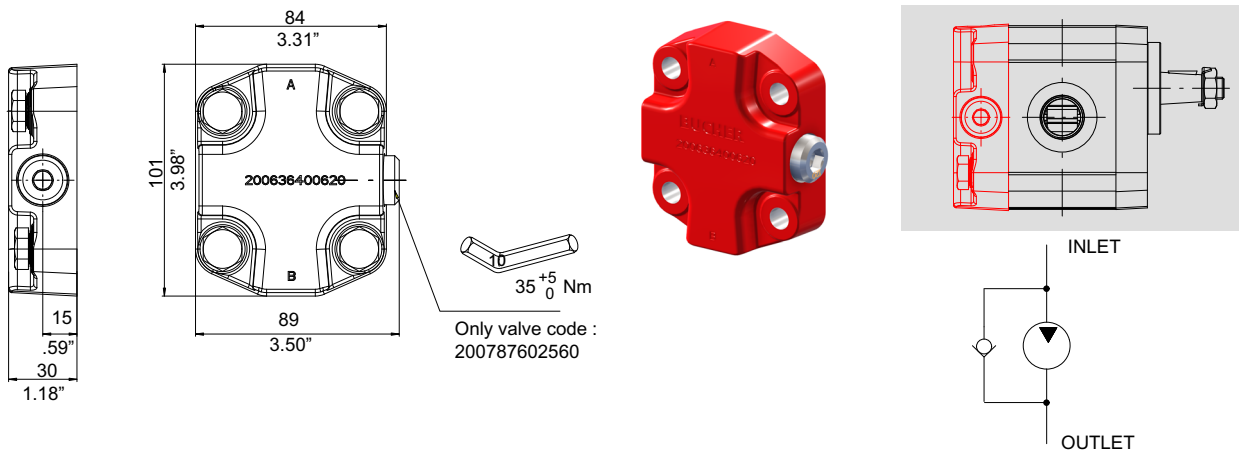

A	P	M	2	1	2	/	8	,	5	-	D	-	A	6	S	-	1	C	-	+	C	A	V				
---	---	---	---	---	---	---	---	---	---	---	---	---	---	---	---	---	---	---	---	---	---	---	---	--	--	--	--

3.7.4 Double anticavitation valves assembled directly inside front cover (cast iron only)

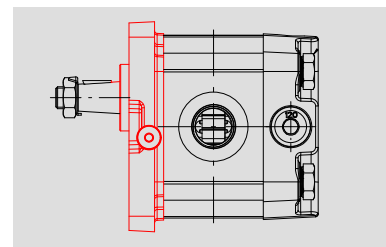
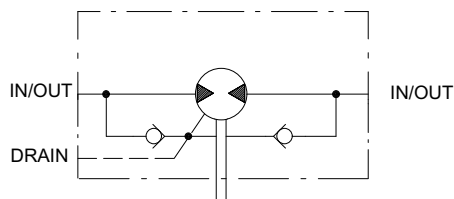

A	P	M	R	2	1	2	/	8	,	5	-		-	A	6	S	-	1	C	-	G	1	+	C	F		
---	---	---	---	---	---	---	---	---	---	---	---	--	---	---	---	---	---	---	---	---	---	---	---	---	---	--	--

3.7.5 Cast iron back cover with integrated valve: antishock-anticavitation valve, fixed setting

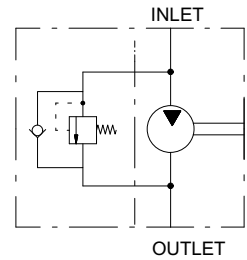
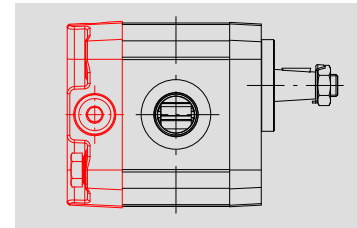
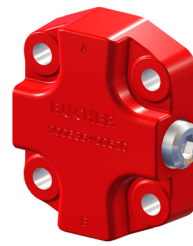
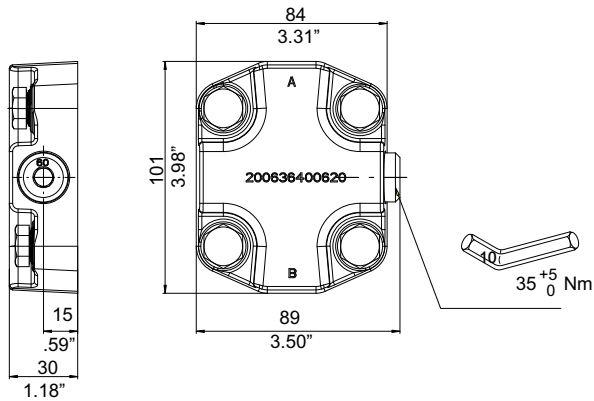

A P M 2 1 2 / 8 , 5 - D - A 6 S - 1 C - U C 1 6

Antishock-anticavitation valve

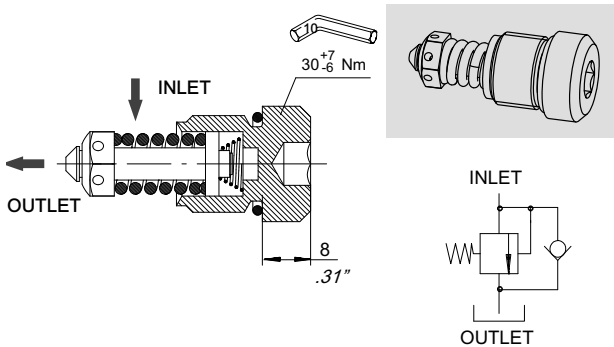

Pressure setting bar (PSI)	Valve code only	Ordering code
40 (580)	200533930068	UC04
60 (870)	200533930077	UC06
80 (1160)	200533930050	UC08
130 (1880)	200533930057	UC13
140 (2030)	200533930059	UC14
150 (2170)	200533930051	UC15
160 (2320)	200533930067	UC16
170 (2460)	200533930071	UC17
180 (2610)	200533930056	UC18
200 (2900)	200533930060	UC20
210 (3040)	200533930080	UC21
220 (3190)	200533930064	UC22
230 (3330)	200533930058	UC23
VC (plug)	200778400310	VC00

Antishock

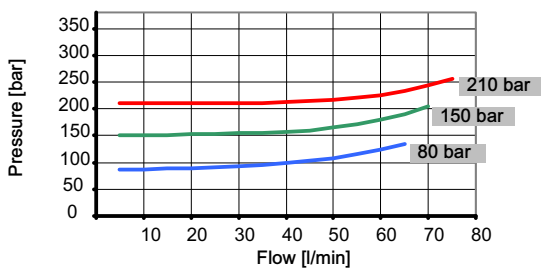

Anticavitation

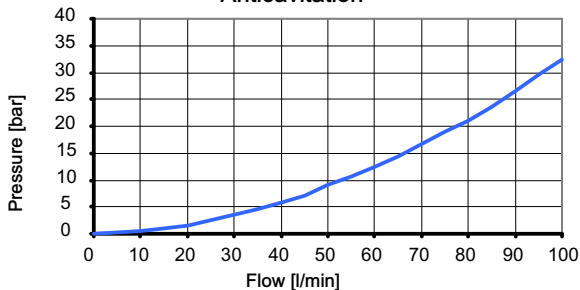

For different pressure settings, please consult Bucher Hydraulics.

3.7.6 Cast iron back cover with drain port and integrated valve: antishock-anticavitation valve, fixed setting

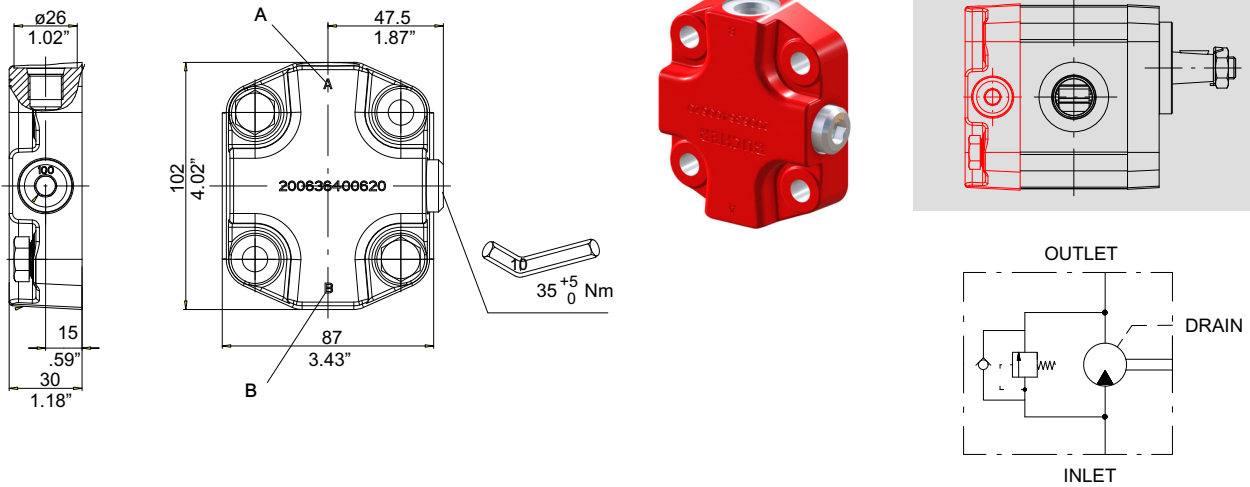

Valve characteristics see section 3.7.5

A	P	M	R	2	1	2	/	8	,	5	-	D	-	A	6	S	-	1	C	-	U	C	1	6	-	G	4
---	---	---	---	---	---	---	---	---	---	---	---	---	---	---	---	---	---	---	---	---	---	---	---	---	---	---	---

UC16 = Antishock-anticavitation valve ordering code
(see section 3.7.5)

G Cast iron back cover

4 = Drain line port type

Drain line port:

Thread	Tightening torque	Ordering code
1/4" BSP	30_{+7}^{-6} Nm	1 (on request)
M12x1.5	30_{+7}^{-6} Nm	3 (on request)
SAE6	20_{+5}^0 Nm	4 (standard)

3.7.7 Cast iron back cover with drain port with integrated valve: Double antishock-anticavitation valves, fixed setting

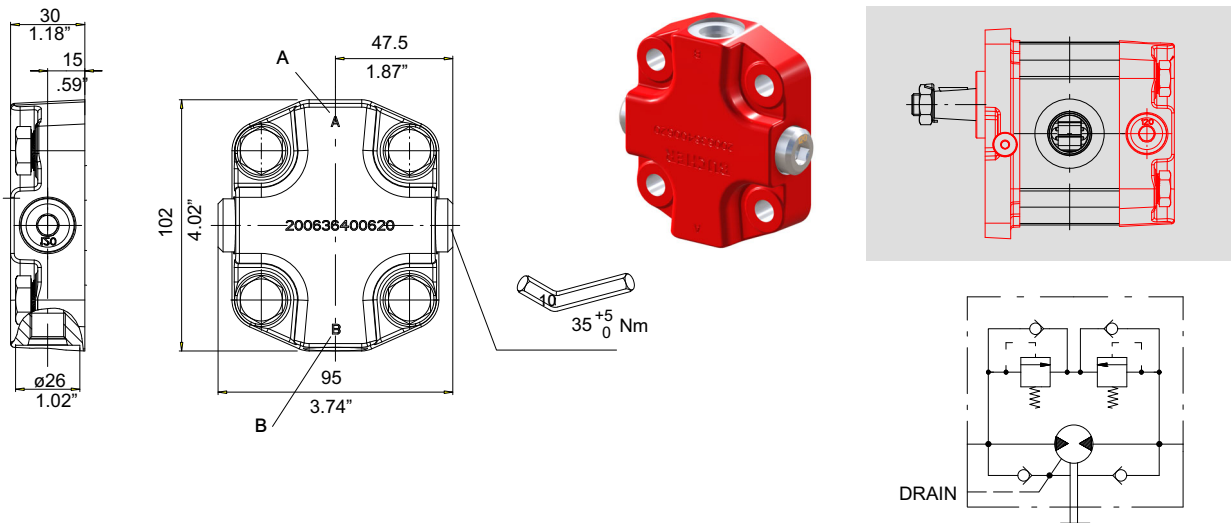

A P M R 2 1 2 / 8 , 5 - A 6 S - 1 C - U C 1 6 - G 4 A + C F

UC16 = Antishock-anticavitation valve ordering code
(see section 3.7.5)

G Cast iron back cover

4 = Drain line port type

Drain line port:

Thread	Tightening torque	Ordering code
1/4" BSP	30 ⁻⁶ / ₊₇ Nm	1 (on request)
M12x1.5	30 ⁻⁶ / ₊₇ Nm	3 (on request)
SAE6	30 ⁻⁶ / ₊₇ Nm	4 (standard)

A = Drain line port position

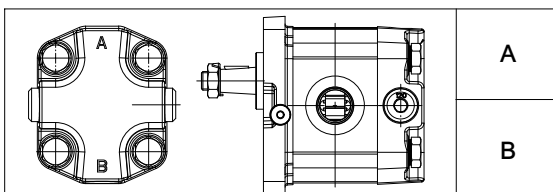

Anticavitation valve integrated inside the front cover is requested, please specify +CF

IMPORTANT! This circuit must be combined with front cover in cast iron, anticavitation valves included (see section 3.7.4)

3.7.8 Cast iron back cover with integrated valves: proportional relief valve ($Q_{max} = 60 \text{ l/min}$)

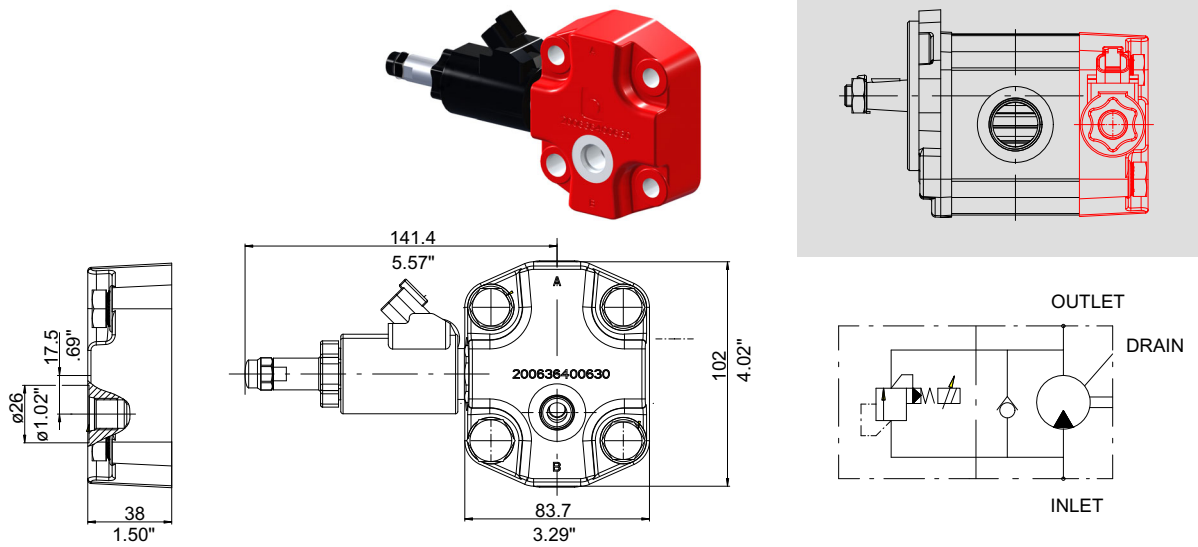

A	P	M	R	2	1	2	/	8	,	5	-	D	-	A	6	S	-	1	C	-	L	2	3	A	4	+	C
---	---	---	---	---	---	---	---	---	---	---	---	---	---	---	---	---	---	---	---	---	---	---	---	---	---	---	---

L = Type of cast iron back cover/valve combination

Back cover with "AL" cavity and proportional pressure-relief cartridge valve type $Q_{max} = 60 \text{ l/min}$

Inverse proportional pressure-relief cartridge, size 5, DBVSA-1LG (NBR seals)

23 = Pressure settings

Pressure range : 10 = 100 bar
16 = 160 bar
23 = 230 bar

For further settings value available please consult Bucher Hydraulics



ATTENTION!

To prevent any pressure surges, outlet port must be routed to tank with the least possible back-pressure. Any tank pressure acting at outlet port is additive to the pressure setting at the main inlet port.



IMPORTANT!

Further note and characteristics available in the dedicated catalogue 400-P-586101-E

$p = f(I)$ Pressure adjustment characteristic ($Q = 5 \text{ l/min}$)

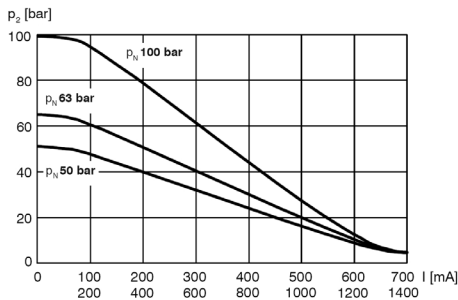

$p = f(I)$ Pressure adjustment characteristic ($Q = 5 \text{ l/min}$)

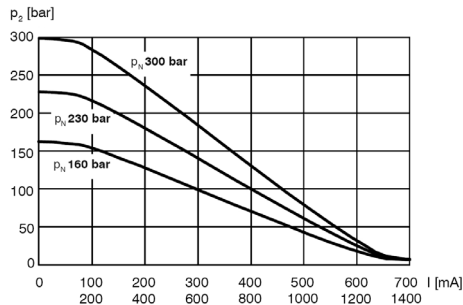

A = Solenoid connection type and nominal voltage

Connection type: DT AJ
A = 12 V DC C = 12 V DC
B = 24 V DC D = 24 V DC



IMPORTANT!

To achieve the proportional pressure-relief cartridge's maximum performance rating, fit the solenoid coil with the plug pins at the top. When fitting the cartridges, note the mounting attitude (preferably vertical, with coil down automatic air bleed) and use the specified tightening torque. No adjustments are necessary, since the cartridges are set in the factory.

4 = Drain line port type

Drain line port:

Thread	Tightening torque	Ordering code
1/4" BSP	30_{-7}^{-6} Nm	1 (on request)
M12x1.5	30_{-7}^{-6} Nm	3 (on request)
SAE6	30_{-7}^{-6} Nm	4 (standard)

If the anticavitation valve integrated inside the motor is requested, please specify +C

3.7.9 Cast iron back cover with integrated valves: proportional relief valve ($Q_{max} = 120 \text{ l/min}$)

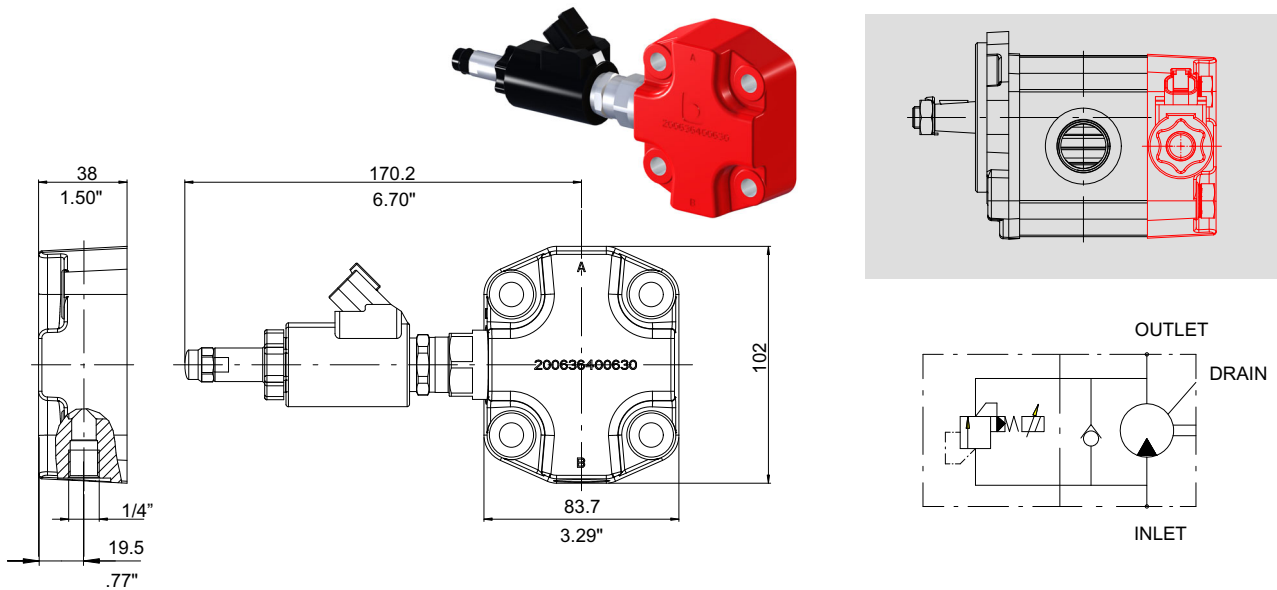

A	P	M	R	2	1	2	/	8	,	5	-	D	-	A	6	S	-	1	C	-	D	2	3	A	1	+	C
---	---	---	---	---	---	---	---	---	---	---	---	---	---	---	---	---	---	---	---	---	---	---	---	---	---	---	---

D = Type of cast iron back cover/valve combination
 Back cover with "DC" cavity and proportional pressure-relief cartridge valve type ($Q_{max} = 120 \text{ l/min}$)

Inverse proportional pressure-relief cartridge, size 10, DBVSA-1CG (NBR seals)

23 = Pressure settings
 Pressure range : 10 = 100 bar
 16 = 160 bar
 23 = 230 bar



ATTENTION!
 To prevent any pressure surges, outlet port must be routed to tank with the least possible back-pressure. Any tank pressure acting at outlet port is additive to the pressure setting at the main inlet port.



IMPORTANT!
 Further note and characteristics available in the dedicated catalogue 400-P-587101-E

For further settings value available please consult Bucher Hydraulics.

$p = f(I)$ Pressure adjustment characteristic ($Q = 5 \text{ l/min}$)

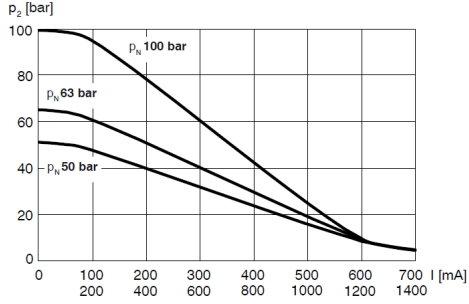

$p = f(I)$ Pressure adjustment characteristic ($Q = 5 \text{ l/min}$)

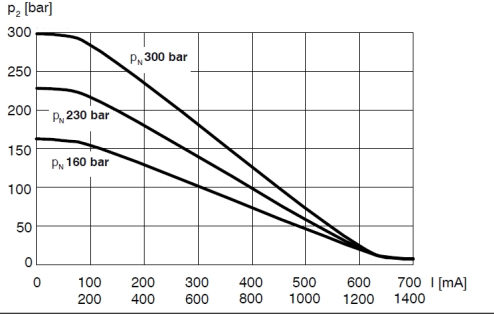

A = Solenoid connection type and nominal voltage



IMPORTANT!
 To achieve the proportional pressure-relief cartridge's maximum performance rating, fit the solenoid coil as shown (with the plug pins at the top). When fitting the cartridges, note the mounting attitude (preferably vertical, with coil down automatic air bleed) and use the specified tightening torque. No adjustments are necessary, since the cartridges are set in the factory.

Connection type: DT AJ
 A = 12 V DC C = 12 V DC
 B = 24 V DC D = 24 V DC

4 = Drain line port type Drain line port:

Thread	Tightening torque	Ordering code
1/4" BSP	30_{+7}^{-6} Nm	1 (standard)
M12x1.5	30_{+7}^{-6} Nm	3 (on request)
SAE6	30_{+7}^{-6} Nm	4 (on request)

If the anticavitation valve integrated inside the motor is requested, please specify +C

3.7.10 Cast iron back cover with integrated valves: Proportional relief valve with ON-OFF reversible valve ($Q_{max} = 60 \text{ l/min}$)



IMPORTANT!

The inverse proportional pressure relief cartridge valve has to be completely open before to switch the Directional Control valve.

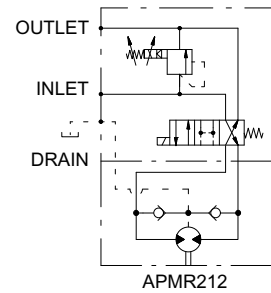
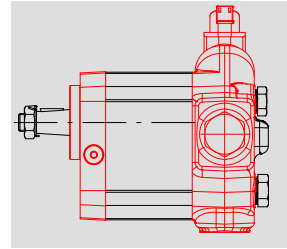
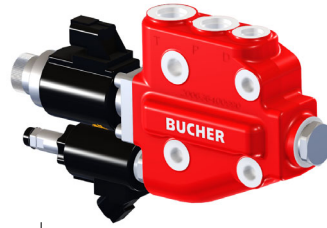
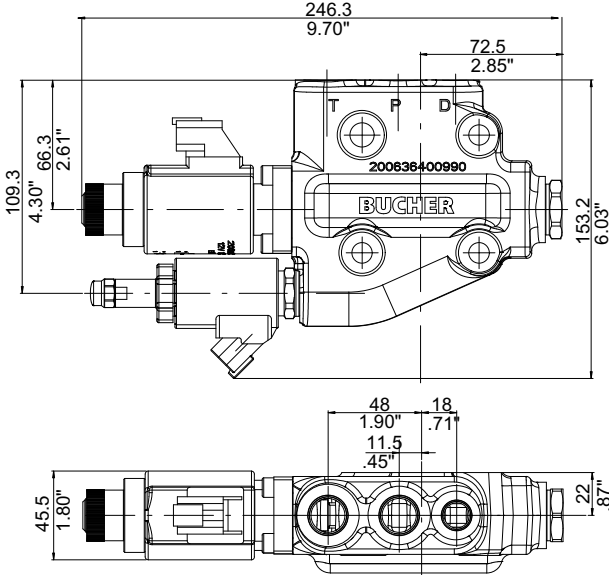

A	P	M	R	2	1	2	/	8	,	5	-	A	6	S	-	0	-	C	2	3	A	3	R	+	C	F	-	D
---	---	---	---	---	---	---	---	---	---	---	---	---	---	---	---	---	---	---	---	---	---	---	---	---	---	---	---	---

C = Type of cast iron back cover/valve

Back cover with "AL" cavity and proportional pressure-relief cartridge valve type $Q_{max} = 60 \text{ l/min}$

Inverse proportional pressure-relief cartridge, size 5, DBVSA-1LG (NBR seals)

23 = Pressure settings

Pressure range: 10 = 100 bar
16 = 160 bar
23 = 230 bar



ATTENTION!

To prevent any pressure surges, outlet port must be routed to tank with the least possible back-pressure. Any tank pressure acting at outlet port is additive to the pressure setting at the main inlet port.



IMPORTANT!

Further note available in the dedicated catalogue: 400-P-586101-E

For further settings value available please consult Bucher Hydraulics.

$p = f(I)$ Pressure adjustment characteristic ($Q = 5 \text{ l/min}$)

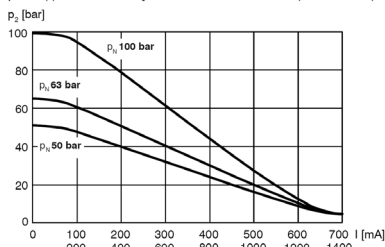

$p = f(I)$ Pressure adjustment characteristic ($Q = 5 \text{ l/min}$)

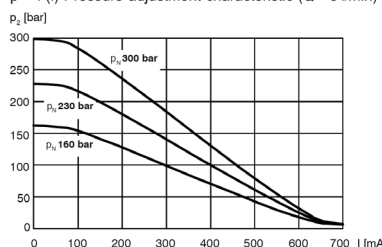

For further characteristics see catalogue: 400-P-586101-E

A = Solenoid connection type and nominal voltage

DT AJ

A = 12 V DC C = 12 V DC

B = 24 V DC D = 24 V DC



IMPORTANT!

To achieve the proportional pressure-relief cartridge's maximum performance rating, fit the solenoid coil with the plug pins at the top. When fitting the cartridges, note the mounting attitude (preferably vertical, with coil down automatic air bleed) and use the specified tightening torque. No adjustments are necessary, since the cartridges are set in the factory.

Anticavitation valve integrated inside the front cover is requested, please specify +CF

Primary rotation with solenoid OFF
D = Right-hand rotation (CW) - S = left-hand rotation (CCW)

Port type	Ordering code	Inlet/outlet threads	Tightening torque	Drain thread	Tightening torque
3	1 (Metric)	M18x1.5	60_0^{+5} Nm	M12x1.5	30_0^{+5} Nm
	3 (SAE)	SAE8	60_0^{+5} Nm	SAE6	30_0^{+5} Nm
	4 (BSPP)	1/2" BSPP	60_0^{+5} Nm	1/4" BSPP	30_0^{+5} Nm

Directional control valve
33 Watt- 12V
Connector type:
DT04-2P ED 100%



IMPORTANT! This circuit must be combined with front cover in cast iron, anticavitation valves included (see section 3.7.4)

3.7.11 Cast iron back cover with drain port with integrated valve: Double antishock-anticavitation valves (fixed setting) with ON-OFF reversible valve ($Q_{max} = 60$ l/min)

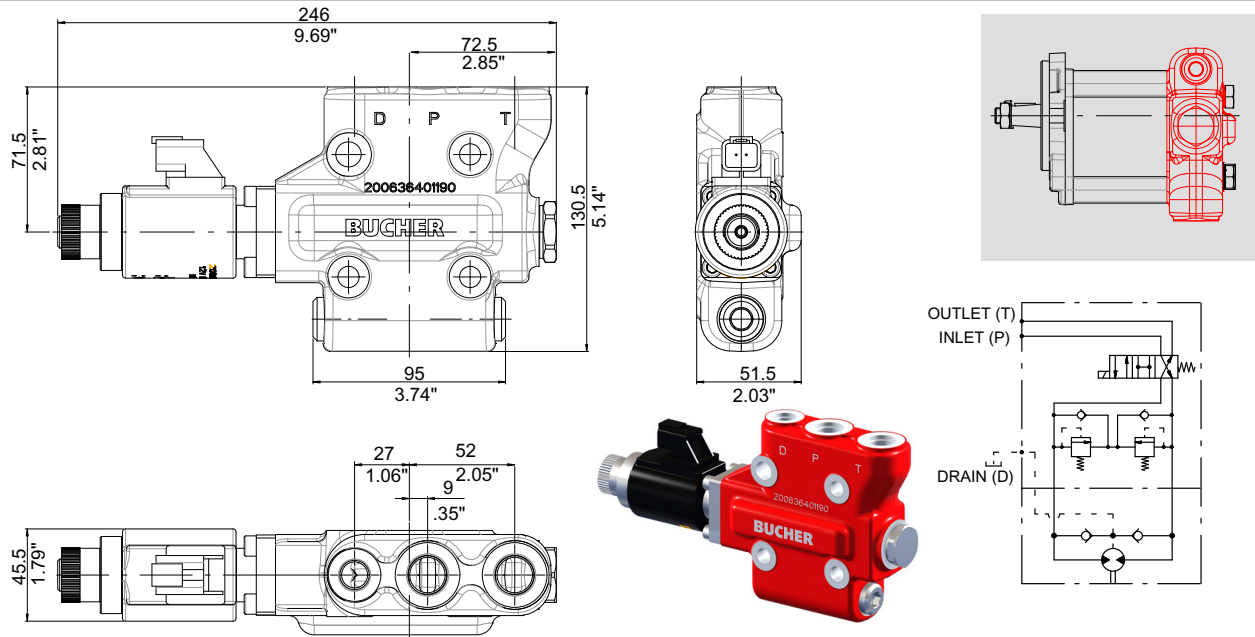

A P M R 2 1 2 / 8 , 5 - A 6 S - 0 - V 2 1 - 3 R + C F - D

V = Type of cast iron back cover/valve

21 = two antishock-anticavitation valves with the same setting

Pressure setting bar (PSI)	Valve code only	Ordering code
40 (580)	200533930068	04
60 (870)	200533930077	06
80 (1160)	200533930050	08
130 (1880)	200533930057	13
140 (2030)	200533930059	14
150 (2170)	200533930051	15
160 (2320)	200533930067	16
170 (2460)	200533930071	17
180 (2610)	200533930056	18
200 (2900)	200533930060	20
210 (3040)	200533930080	21
220 (3190)	200533930064	22
230 (3330)	200533930058	23

For different pressure settings please consult Bucher Hydraulics.

3 = Port type

Ordering code	Inlet/outlet threads	Tightening torque	Drain thread	Tightening torque
1 (Metric)	M18x1.5	60 ₀ ⁺⁵ Nm	M12x1.5	30 ₀ ⁺⁵ Nm
3 (SAE)	SAE8	60 ₀ ⁺⁵ Nm	SAE6	30 ₀ ⁺⁵ Nm
4 (BSPP)	1/2" BSPP	60 ₀ ⁺⁵ Nm	1/4" BSPP	30 ₀ ⁺⁵ Nm

Anticavitation valve integrated inside the front cover is requested, please specify +CF

Primary rotation with solenoid OFF
D = Right-hand rotation (CW) - S = left-hand rotation (CCW)

Directional control valve
33 Watt - 12V
Connector type:
DT04-2P ED 100%

IMPORTANT! This circuit must be combined with front cover in cast iron, anticavitation valves included (see section 3.7.4)

4 Accessories

4.1 Electronic module, ESLF series

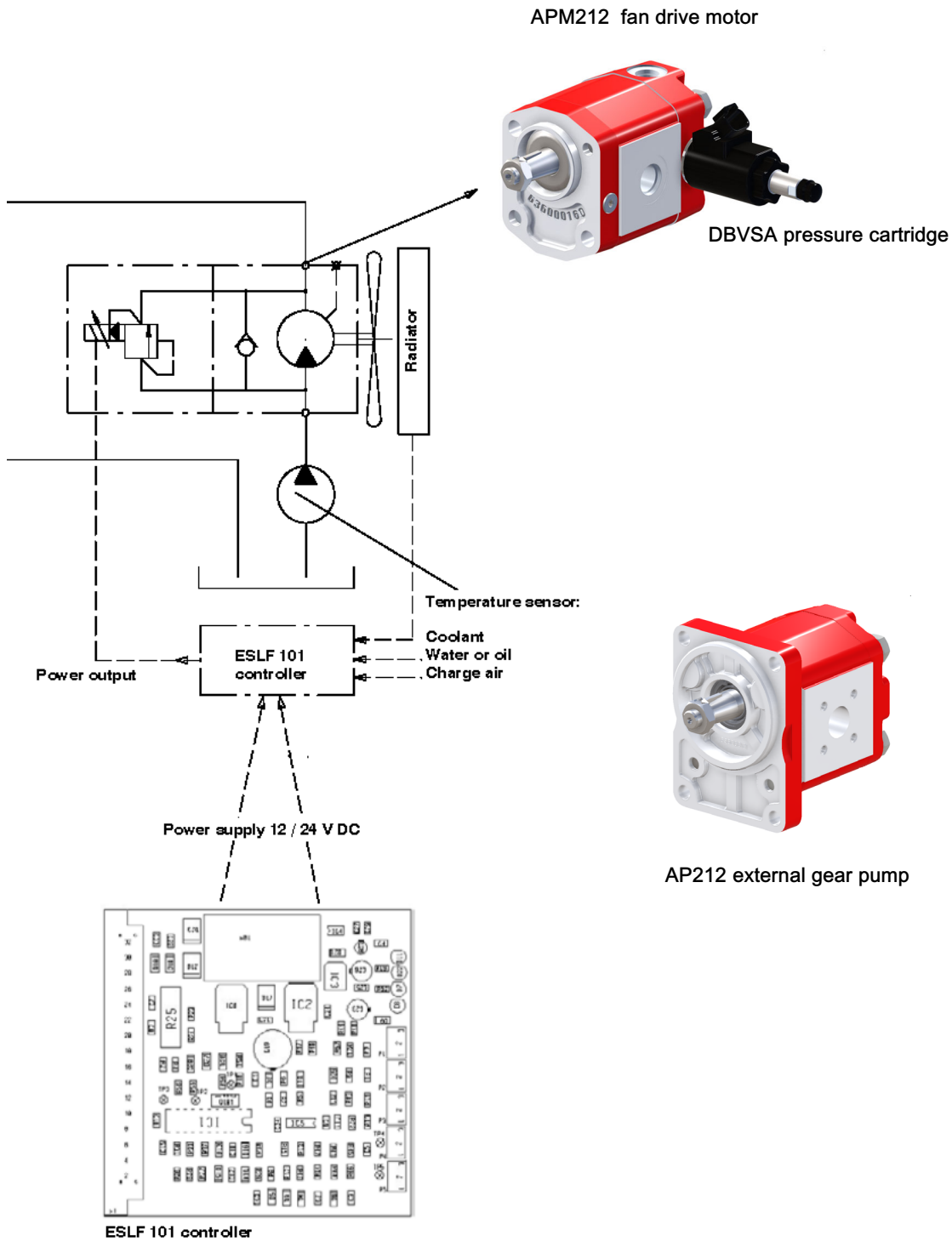

- Up to 3 temperature sensor can be used
- PTC and NTC sensor can both be used

- Same electronic system for reversible and non-reversible motors
- Can be supplied with or without housing

Control system features	
Power supply	12 V - 30 V DC
Reference voltage	8 V DC max. 20 mA
Temperature inputs	3 (T1, T2, T3)
Temperature sensor processing (U sensor)	Either PTC or NTC per card, using two-wire method
Temperature control range	0°C - 100°C
Setting type of sensor; adjustment	Diagnostics input online; calibration potentiometer for each sensor
Prop. solenoid output for fan motor -max. fan motor speed -min. fan motor speed	max. Output current $I_{max}= 2,1$ A minimum current $I_{max}= 0,2$ A maximum current (adjustable) $I_{max}= 2,1 - 1,4$ A via potentiometer
ON/OFF solenoid output	Max. output current 2.5 A
Diagnostics	LED for each solenoid output LEDs for control mode
Electrical connection	DIN 41612 Type D edge connector, or screw terminals
Type of protection	non-encapsulated and encapsulated models
Dimensions	100 mm x 100 mm x 25 mm (W x H x D)
Temperature range	-20°C to +50°C

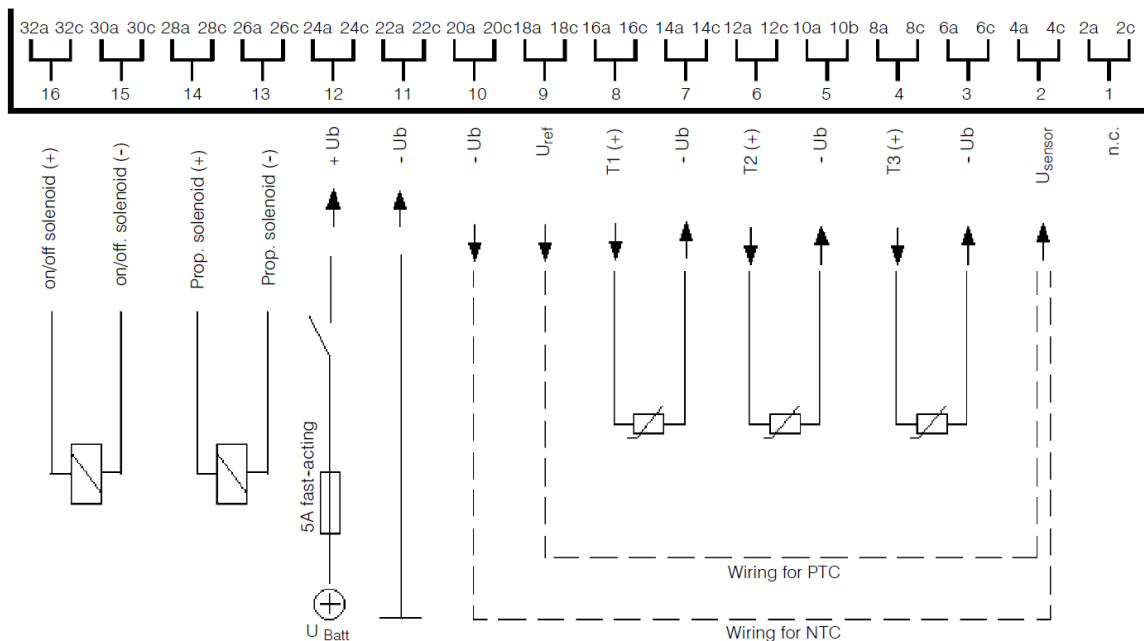

E S L F 1 0 1 - 8 1 * * *

Electronic fan drive controller, series ESLF

Encapsulated = 8

Non-encapsulated = 9

Screw terminals = 1

Edge connector = 0

Suitable for 12 V and 24 V DC

IMPORTANT! For detailed informations, see www.bucherhydraulics.com

4.2 External manifold for reversing control, STB series

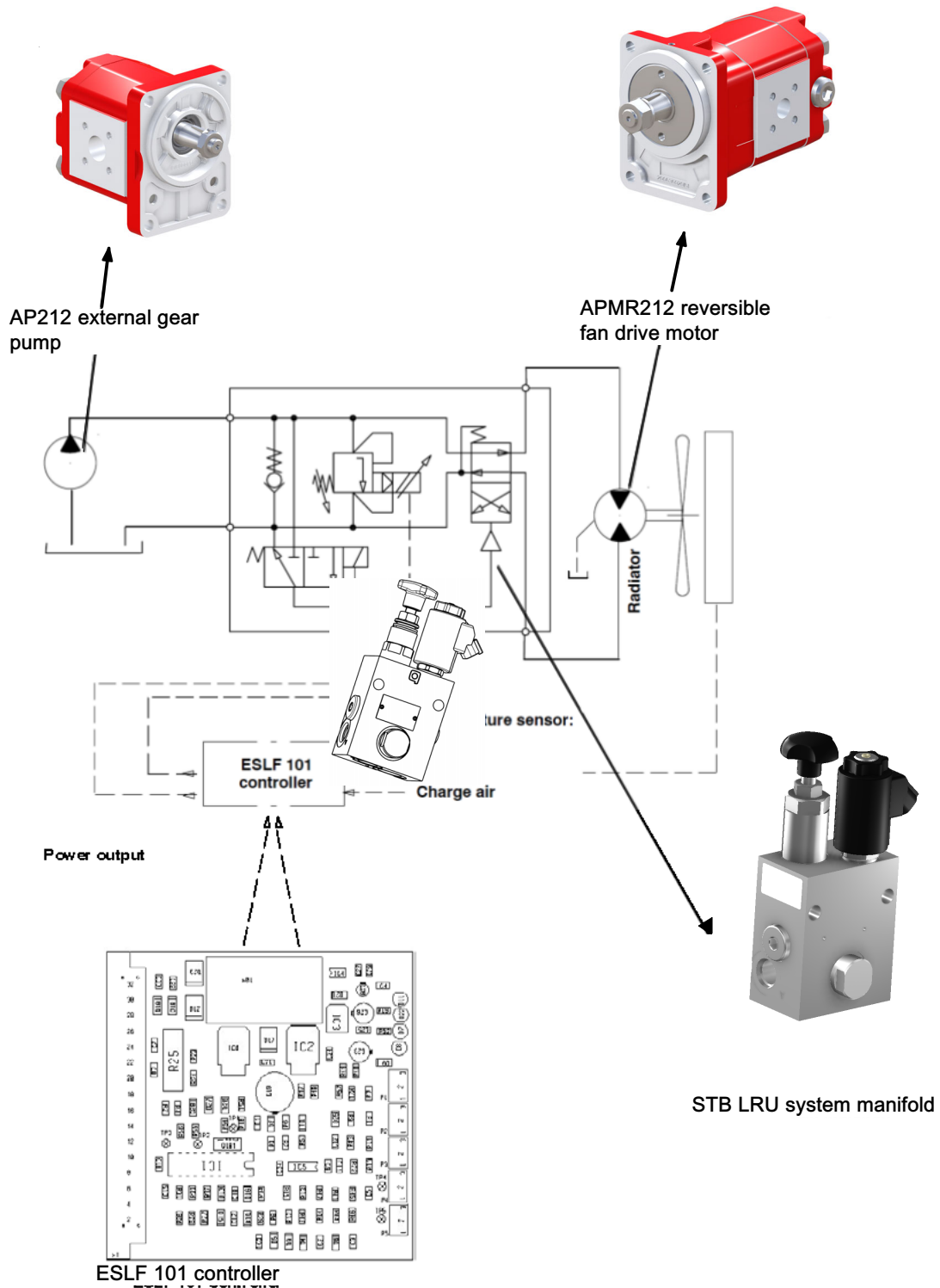

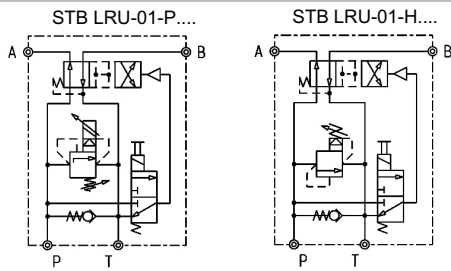

P_{max} = 250 bar
 Q_{max} = 50 l/min

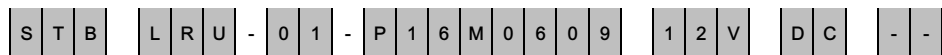
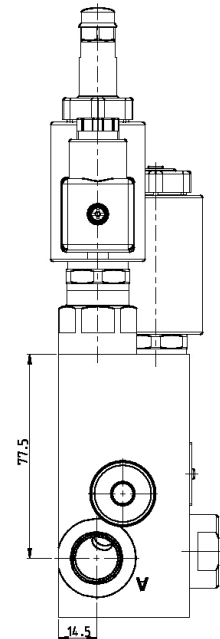
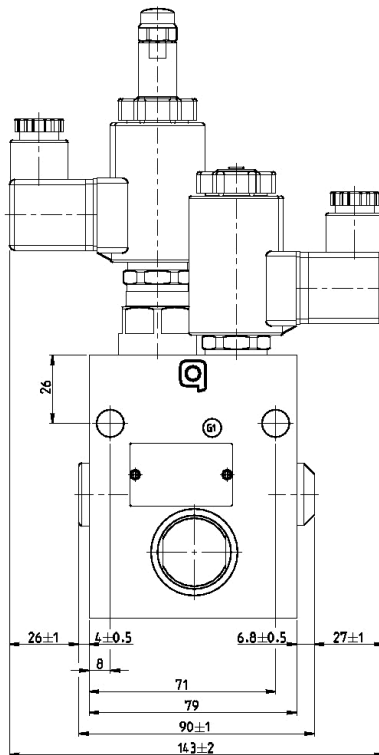
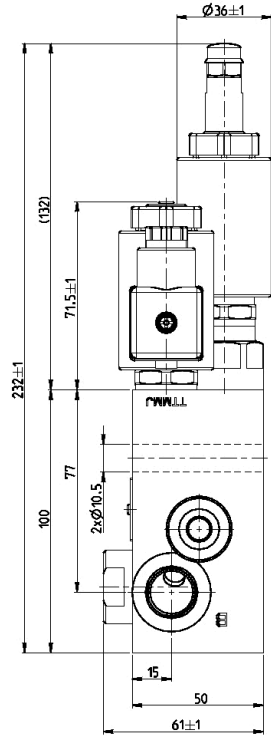
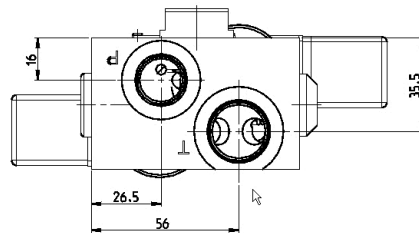

System manifold series STB

With reversal of fan rotation, LRU

Design no.: 01

Pressure control valves:

P = Proportional, model DBVSA-1CG-...-10

H = manual adjustment, model DVPA-1-10....

W = electric model W UVPZ-1-10...

Pressure setting: 10 = 100 bar 16 = 160 bar 23 = 230 bar

Port thread:	M	G	U
P / A / B	M18x1,5	3/8"	3/4-16UNF
T	M22x1,5	1/2"	7/8-14UNF

Nominal size 06= 6 mm

Minimum flow for reversal switching 09= 9 l/min

Voltage and current plainly specified: 12 V DC

24 V DC For others, contact Bucher Hydraulics

Solenoid coil connectors: Blank = with DIN 43650 / ISO 4400 (standard) J = Junior-Timer radial
M100 = without DIN Mating plug F = free cable ends / flying leads (length: 500 mm)
C = Kostal M27x1 I = Junior-Timer axial
D = Deutsch DT-2

T = with quenching diode P6KE33CA

IMPORTANT! For detailed informations, see www.bucherhydraulics.com

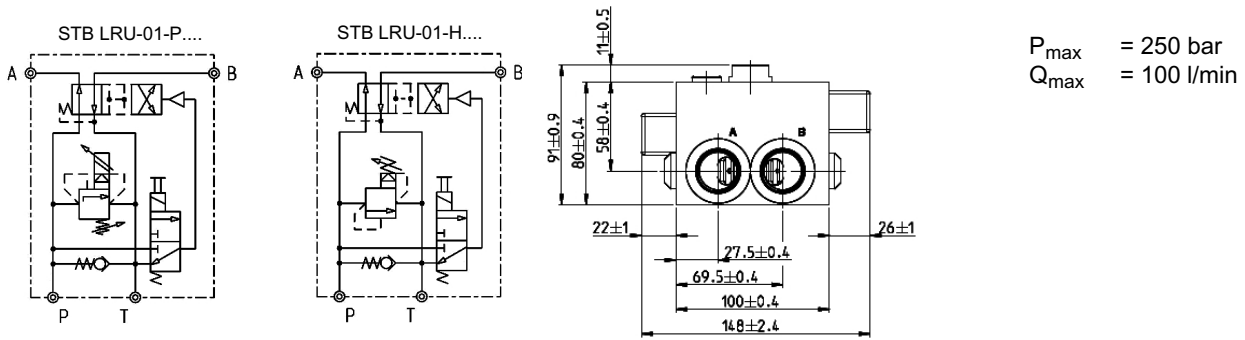

$P_{max} = 250 \text{ bar}$
 $Q_{max} = 100 \text{ l/min}$

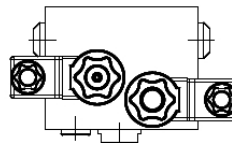
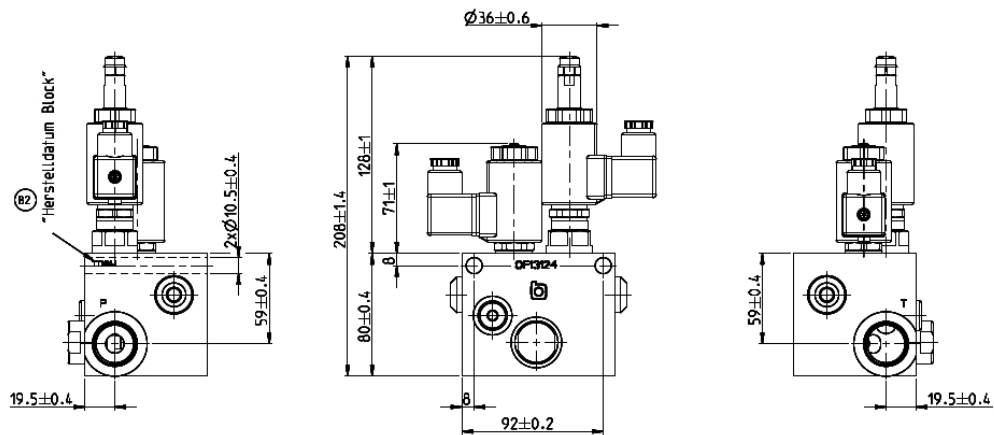

System manifold series STB

With reversal of fan rotation, LRU

Design no.: 01

Pressure control valves:

P = Proportional, model DBVSA-1CG-...-10

H = manual adjustment, model DVPA-1-10....

Pressure setting: 10 = 100 bar 16 = 160 bar 23 = 230 bar

Port thread: P / A / B = M26x1,5 3/4" 1 1/16-12UNF
 T = M26x1,5 3/4" 1 1/16-12UNF

Nominal size 10= 10 mm

Minimum flow for reversal switching 30= 30 l/min

Voltage and current plainly specified: 12 V DC

24 V DC For others, contact Bucher Hydraulics

Solenoid coil connectors: Blank = with DIN 43650 / ISO 4400 (standard) J = with plug connectore Junior-Timer radial
 M100 = without DIN Mating plug F = free cable ends / flying leads (length: 500 mm)
 C = with plug connector Kostal

Quenching diode (specify if requested)

IMPORTANT! For detailed informations, see www.bucherhydraulics.com

5 Product identification plate

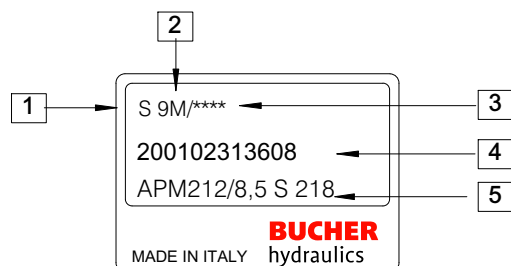

- 1 : Rotation (D= Clockwise rotation -
S= Counterclockwise rotation)
- 2 : Manufacturing year and month
- 3 : Progressive identification no. (optional)
- 4 : Bucher Hydraulics S.p.A. product code
- 5 : Description

Single motor weight

Motor	Weight Kg**
APM-APMR212/8.5	2.7
APM-APMR212/11	2.8
APM-APMR212/15	3.0
APM-APMR212/19	3.2
APM-APMR212/22	3.3
APM-APMR212/26	3.4

N.B.: The weight refers to motors with aluminium front cover and standard cast iron back cover.

Manufacturing month	Manufacturing year						
	2017	2018	2019	2020	2021	2022	2023
January	7A	8M	9M	0M	1M	2M	3M
February	7B	8N	9N	0N	1N	2N	3N
March	7C	8P	9P	0P	1P	2P	3P
April	7D	8Q	9Q	0Q	1Q	2Q	3Q
May	7E	8R	9R	0R	1R	2R	3R
June	7F	8S	9S	0S	1S	2S	3S
July	7G	8T	9T	0T	1T	2T	3T
August	7H	8U	9U	0U	1U	2U	3U
September	7I	8V	9V	0V	1V	2V	3V
October	7J	8Z	9Z	0Z	1Z	2Z	3Z
November	7K	8X	9X	0X	1X	2X	3X
December	7L	8Y	9Y	0Y	1Y	2Y	3Y

6 Application form

Date:			
Contact:			
Customer:			
Location:			
Overall quantity per year:			
Minimum batch size:			
Delivery time requested:	Feasibility:	Prototypes:	Series:
Target price:			
Type of application:	(Cooling systems requires F, I, N or Q front cover)		

External gear motor general data					
Rotation	S	D	R	Peak work pressure (bar)	
Displacement: Single motor (cm ³ /rev)				Continuous work pressure (bar)	
Drive shaft				Oil type	
Port type				Oil temperature (°C)	min max
Front cover type				Oil viscosity (cSt)	min max
Bearing support				Outlet line pressure	
Front cover material				Voltage	
Back cover type/circuit				Drain case pressure	
Back cover material	aluminium	cast iron		Radial load (N)	
Valves				Axial load (N)	
Speed range				Working hours per year	
				Cycles per year	

Additional notes:

info.it@bucherhydraulics.com

www.bucherhydraulics.com

© 2020 by Bucher Hydraulics S.p.A, I-42124 Reggio Emilia

All rights reserved.

Data is provided for the purpose of product description only, and must not be construed as warranted characteristics in the legal sense. The information does not relieve users from the duty of conducting their own evaluations and tests. Because the products are subject to continual improvement, we reserve the right to amend the product specifications contained in this catalogue.

Classification: 410.110.000