



OIL SOLUTIONS

PO Box 38
Strathfieldsaye, VIC, 3551
1800 OIL SOL
1800 645 765

sales@oilsolutions.com.au

www.oilsolutions.com.au

"For All Your Hydraulic Needs"

BUCHER
hydraulics

APM212HP Cast Iron Gear Motors, including Fan Drive

Standard and Low Noise series

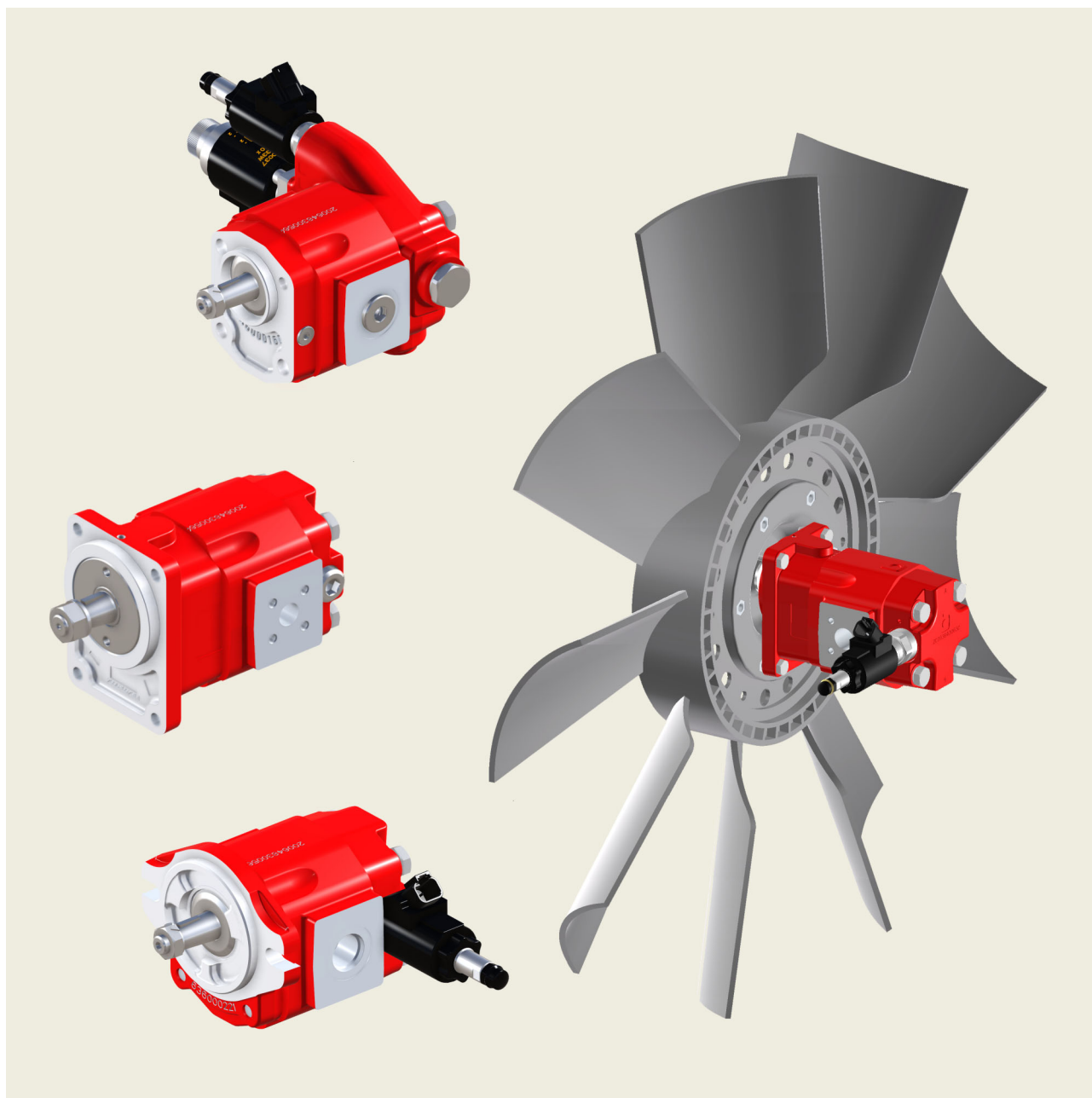

Reference: 200-P-991244-E-03

Contents

Page

| | | |
|----------|---|-----------|
| 1 | General information | 3 |
| 1.1 | External gear motors for general use | 3 |
| 1.2 | Fan Drive Gear Motors for cooling systems | 4 |
| 1.3 | External gear motors components | 5 |
| 1.4 | Technical data | 6 |
| 1.5 | High inlet pressure | 6 |
| 1.6 | Identifying the rotation direction | 7 |
| 1.7 | Outlet | 7 |
| 1.8 | Radial and axial load | 8 |
| 1.9 | Application check | 8 |
| 1.10 | General installation precaution | 10 |
| 1.11 | Directives and standards | 11 |
| 1.12 | Non-standard symbols used in the text | 11 |
| 1.13 | Gear motor formulas | 11 |
| 1.14 | Diagrams APM212HP | 12 |
| 2 | Overview standard types | 14 |
| 2.1 | Standard configuration | 14 |
| 3 | APM212HP Single motor customised versions | 31 |
| 3.1 | Single motor customised versions order example | 32 |
| 3.2 | Single motor dimensions | 33 |
| 3.3 | Shaft end code | 34 |
| 3.4 | Front cover | 35 |
| 3.5 | Cast iron body | 38 |
| 3.6 | Back covers | 41 |
| 3.7 | Valves and circuits | 42 |
| 4 | Accessories | 50 |
| 4.1 | Electronic module, ESLF series | 50 |
| 4.2 | External manifold for reversing control, STB series | 52 |
| 5 | Motors seal kit NBR + HNBR standard type | 55 |
| 6 | Product identification plate | 55 |
| 7 | Application form | 56 |

1 General information

External gear motors are widely used in modern hydraulic systems due to their high performance, long service life and low maintenance costs.

With the new APM212HP family, high operating pressures, excellent volumetric and mechanical efficiencies were achieved; moreover, for LN-series (Low Noise versions), definitely better acoustic performances were obtained.

Different features of the new APM design were deeply analyzed and studied in order to get to the above mentioned results; primarily, engineering attention was focused on the design of the gear teeth and balancing areas but also

materials, heat treatments and coupling tolerances were carefully considered during the development process; these project variables linked to a continuous tight test schedule (even performed in our semi-anechoic room) were the tools adopted by Bucher to achieve the excellent performance of these gear motors.

Bucher Hydraulics philosophy is based on continuous improving; this concept is enforced by high-end control and manufacturing techniques in Production and by a Quality Control System which guarantees that every single product can offer the same high standard level.

1.1 External gear motors for general use

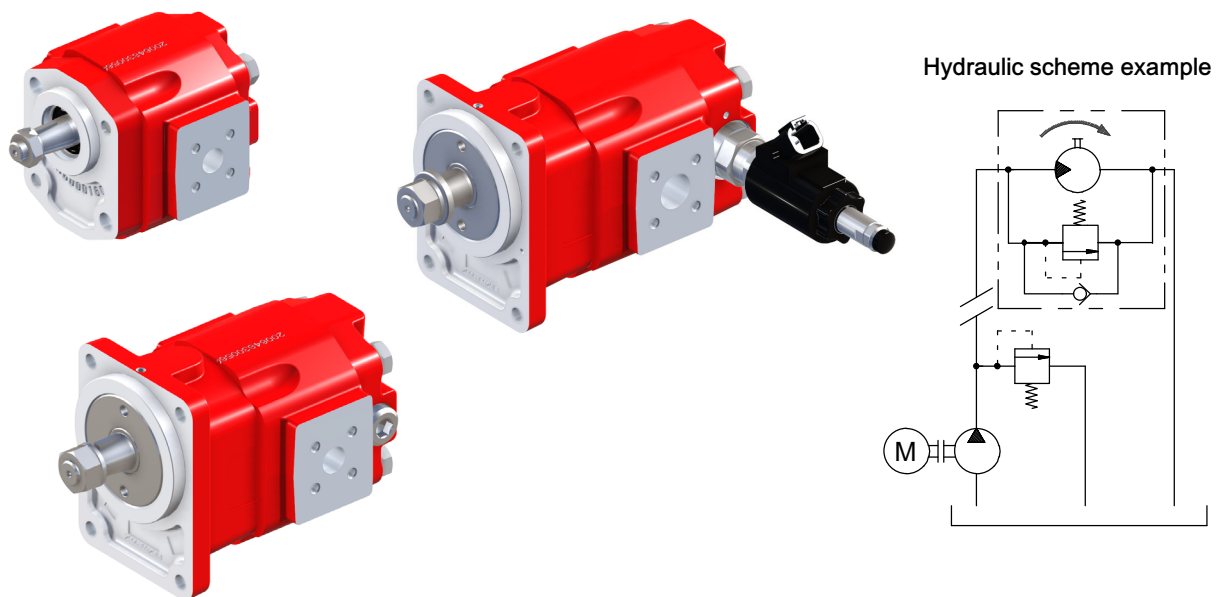

New APM212HP motors benefits

- High hydraulic and mechanical efficiencies
- Able to withstand high pressure
- Long life due to optimised materials used
- Low Noise and vibration features available also in "standard" version
- Low Noise motors with new gears profile available out-rigger bearing available

Examples of typical applications



1.2 Fan Drive Gear Motors for cooling systems

In the Fan Drive Gear Motors for cooling systems we implemented the shaft seal protection adding a dedicated sealing. Consequently, dedicated cast iron front covers have been designed. See section 3.4.2

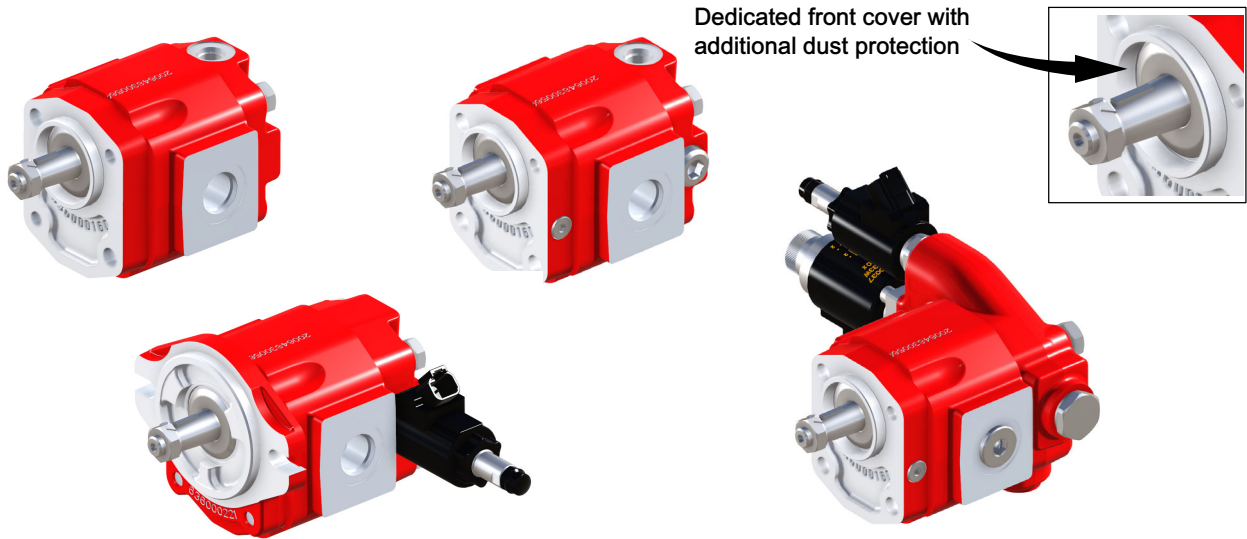

New APM212HP motors benefits

- Improve machine operating efficiency
- Reduce the costs of maintenance
- Reduce noise and vibrations
- Allow to integrate hydraulic values circuit
- Electronic control available

Examples of typical applications

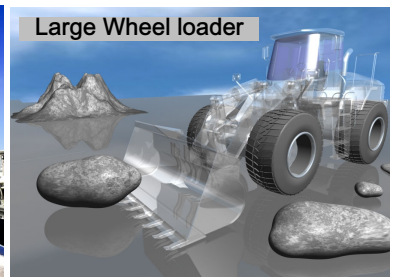

Hydraulic scheme examples

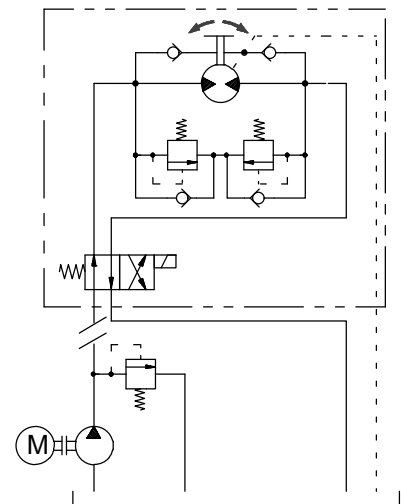
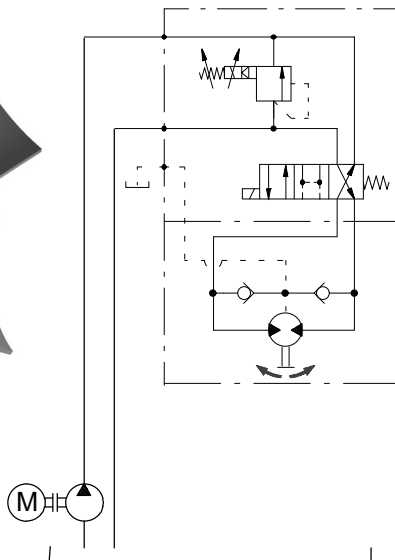
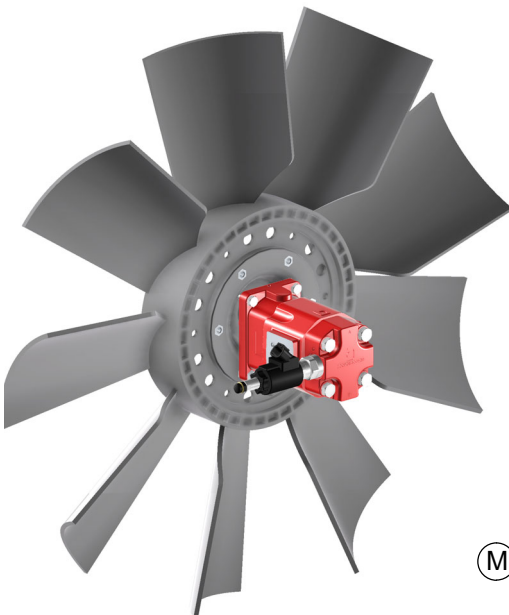

1.3 External gear motors components

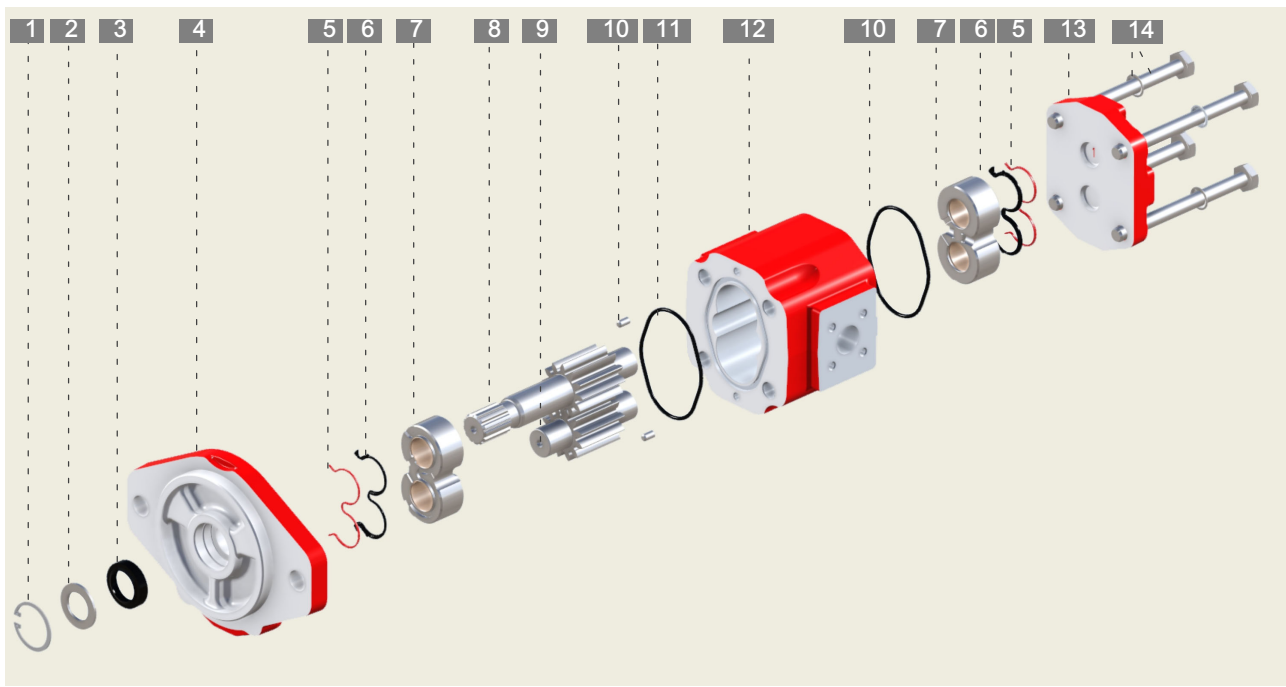

- | | |
|----------------------------|-----------------------------|
| 1. Retaining ring | 8. Take off power gear |
| 2. Shaft seal ring support | 9. Gear |
| 3. Shaft seal | 10. Oil seal |
| 4. Cast iron front cover | 11. Centering pin |
| 5. Back up seal | 12. Cast iron motor body |
| 6. Balancing seal | 13. Cast iron back cover |
| 7. Balancing block | 14. Fixing screw and washer |

1.4 Technical data

| Features | | |
|--|--|--|
| Operating fluid temperature range (mineral oil): | NBR HNBR | -15 / +80 °C (peak: -20 / +90 °C) -20 / +90 °C (peak: -30 / +110 °C) |
| Recommended fluids | | hydraulic mineral oil-based |
| Viscosity range: | Recommended Permitted Permitted for starting | 20-120 mm ² /s (cSt) up to 700 mm ² /s (cSt) 2000 mm ² /s (cSt) |
| Cleanliness: | recommended up to 140 bar (2000 PSI) recommended up to 210 bar (3000 PSI) recommended up to 275 bar (4000 PSI) | 20/18/15 ISO 4406 19/17/14 ISO 4406 17/15/12 ISO 4406 |
| Minimum storage temperature: | NBR HNBR | -25 °C -35 °C |
| Standard seals material (valves not included) | | NBR + HNBR standard (ISO1629) |

| Type | APM/ APMR212HP Displacement | | APM/ APMR212HPLN Displacement | | Max. pressure** | | | | n min. P2 < 100 bar rpm | n min. 100<n< 180 bar rpm | n min. 180<n< P2 rpm | n max. rpm |
|--------|-----------------------------------|----------------|-------------------------------------|----------------|--------------------|------|--------------|------|----------------------------------|------------------------------------|-------------------------------|---------------|
| | cm ³ /rev | Cu.In. P.R. | cm ³ /rev | Cu.In. P.R. | P1 (continuous) | | P3 (peak) | | | | | |
| | | | | | bar | psi | bar | psi | | | | |
| 15 | 15.1 | .921 | 15.7 | .958 | 250 | 3630 | 300 | 4350 | 500 | 750 | 1000 | 3500 |
| 19 | 19.2 | 1.172 | 19.8 | 1.208 | 250 | 3630 | 300 | 4350 | 500 | 750 | 1000 | 3500 |
| 22 | 22.2 | 1.355 | 23 | 1.404 | 250 | 3630 | 300 | 4350 | 500 | 750 | 1000 | 3000 |
| 26 | 26.2 | 1.599 | 27.1 | 1.654 | 250 | 3630 | 280 | 4060 | 500 | 750 | 1000 | 2800 |
| 29 (*) | 28.9 | 1.764 | 29.9 | 1.825 | 220 | 3190 | 250 | 3630 | 500 | 750 | 1000 | 2500 |
| 33 (*) | 33 | 2.014 | 34.1 | 2.081 | 200 | 2900 | 240 | 3480 | 500 | 750 | 1000 | 2400 |

(*) Displacements on request: please contact our Sales Department.

(**) Referred to motors with flanged ports. Utilising threaded ports, please to consider a significantly de-rated performances.

The mechanical stress localised on threaded ports cause a re-duced motor life performances



IMPORTANT! Please consult Bucher Hydraulics if even one of the operating limits indicated in the table (temperature, pressure, rpm) is exceeded, as well as in the case of two or more maximum values at the same time, or for applications with particularly heavy-duty cycles

1.5 High inlet pressure

Pressure levels:

P1 = continuous pressure

P3 = max peak pressure

Application of motor operating at a high number of load cycles has to be submitted to our approval.

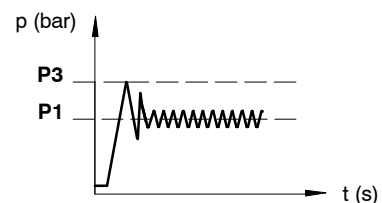

1.6 Identifying the rotation direction

The rotation direction of a gear motor is identified by looking at the motor from the front and with the drive gear turned upwards (see figures below).

Motors with clockwise rotation (D) have a drive gear which turns clockwise, with the inlet port on the left and the outlet port on the right.

Motors with counterclockwise rotation (S) have a drive gear which turns counterclockwise, with the inlet port on the right and the outlet port on the left.

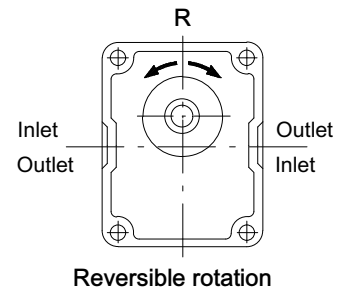
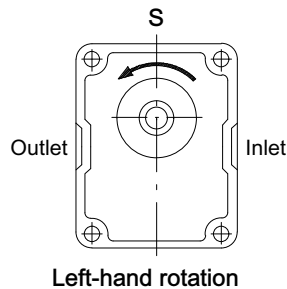
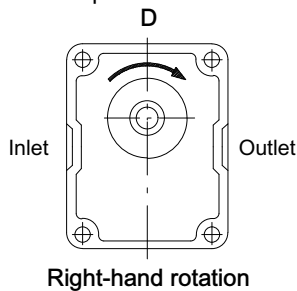

The figure also shows the pressure flow inside the motors as the oil is transferred from the inlet port to the outlet port.

As regards reversible motors (R), the ports are alternatively for inlet and outlet.

Motors with a unidirectional rotation (D or S) have the denomination APM. Motors with reversible rotation have the denomination APMR. Motors with "Low Noise" components have the denomination LN.

1.7 Outlet

1.7.1 Unidirectional motors

As a matter of principle, unidirectional motors correspond to counter rotating motors.

The balancing seals are not symmetric and, consequently, two different pressure sides: inlet High-pressure and outlet Low-pressure side, which must not be exchanged each other, are defined.

The outlet Low-pressure side loads the back side of the oil retaining shaft seal, a dedicated steel ring for supporting it, is adopted.

The maximum outlet Low-pressure value is limited by the shaft seal and its support, see limit indications, page 9/56

To keep P out below the suggested value, the following must be avoided:

- long distance between motor and tank
- long stretches of piping
- special features such as: bends; reductions in diameter;

quick couplings; etc.

Having filtration on the return it is also advisable to choose a filter of a suitable size to minimise any pressure drop and to take measures to prevent gradual clogging over time.

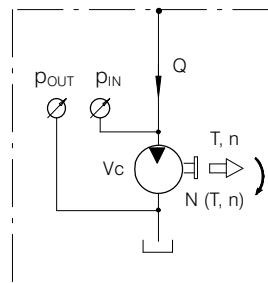

1.7.2 Reversible motors

Reversible rotating motors have symmetric balancing seals and both port, inlet and outlet, can be, alternatively, operate as inlet High-pressure and outlet Low-pressure port.

A sealed area is connected to the back side of the oil retaining shaft seal and its pressure must be limited connecting it to the tank, through a drain threaded port, which is generally, placed on the motor rear cover.

The drain hose must be chosen in order to avoid that the pressure at the drain port does not exceed the maximum admitted pressure, see limit indications, page 9/56.

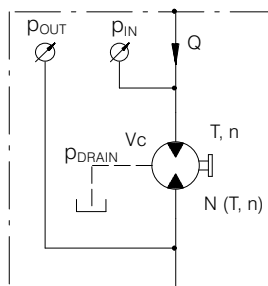

1.8 Radial and axial load

1.8.1 Standard version

Bucher APM212 gear motors are suitable to work also when radial and axial loads are applied to it.

In order to guarantee the correct life of the hydraulic motor, it is necessary to let the component work within the limits indicated in the table below:

| | |
|-------------|-------|
| Radial load | 100 N |
| Axial load | 500 N |

1.8.2 Bearing front cover support

High values of radial and axial loads can cause the wear of the motor internal components; as a consequence, motor performance and life can be dramatically reduced.

Bucher Hydraulics studied special front covers having a bearing on-board which allow the motor to tolerate loads higher than the previous ones shown in 1.8.1

When the hydraulic motor is assembled in an application using a coupling, the joint must be able to absorb any discrepancies in the coaxial alignment of the gear motor-driven shaft without applying any loads on the motor shaft.

In the coupling between splined shafts, the connection sleeve must be free to move along its axis; the length of this

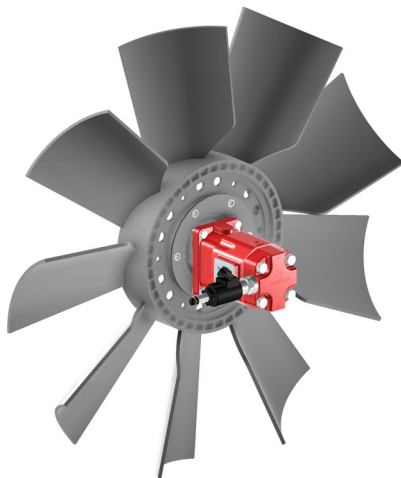

1.9 Application check

In order to extend the life of the gear motor (which depends on motor speed, system pressure, and other system parameters), Bucher Hydraulics strongly recommends the following actions:

- **Perform a prototype testing programme** in order to check its functionality and its behaviour with the machine which will be equipped with this component.
- **Avoid cavitation**; every action which reduces the quantity of air trapped in the system is worth to extend all system components life.
- **A maintenance of the fluid and of the filtering system** has to be regularly accomplished. A clean fluid can extend the life of the system reducing its consequent failures.

What shown must be considered the worst load conditions which our motors have to submit to.

Radial load: the maximum admissible radial loads must be calculated considering both the fan weight and the unbalanced mass.

Axial load: the limits of axial loads apply to both directions (in inwards and in outwards).

When radial and/or axial loads exceed the above stated values, a front bearing support must be adopted.

sleeve must be sufficient to fully cover the splined sections of the motor-driven shaft in any of its positions. A clearance between shaft ends is necessary.

It's important to check that the spline coupling is reasonably lubricated allowing its protection against a rapid deterioration.

Should any radial and/or axial loads be applied to the take-off-shaft (e.g. when it is coupled to a V-belt and pulley or to a pair of gear wheels), a front cover with supporting bearings.

Depending on the motor model, these supports can replace the front cover of the motor or can be fitted in addition to it (assembling it on the front cover itself).

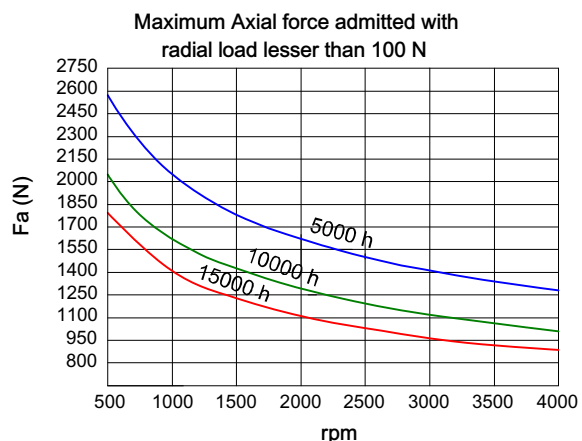

Before to introduce the motor into the machine it is necessary to check if the application match the motor specifications. In particular:

1. Pressure limits

It is important to remain inside the catalogue limits as P1 (continuous) and P3 (peak) see section 1.2.

2. Return line and/or case drain line

The case drain line must be connected directly to tank if possible using a dedicated connection. The connection size should be dimensioned with appropriated internal passage in order to maintain as low as possible the pressure inside. The max allowed pressure depending on the speed and the viscosity. See limit indications, page 9/56

Limit indications:

Shaft seal: Maximum pressure admitted

IMPORTANT! The pressure on the outlet line has to be checked in order to choose the right motor configuration. Different solutions are available depending on pressure value recorded. See examples from 1 to 4

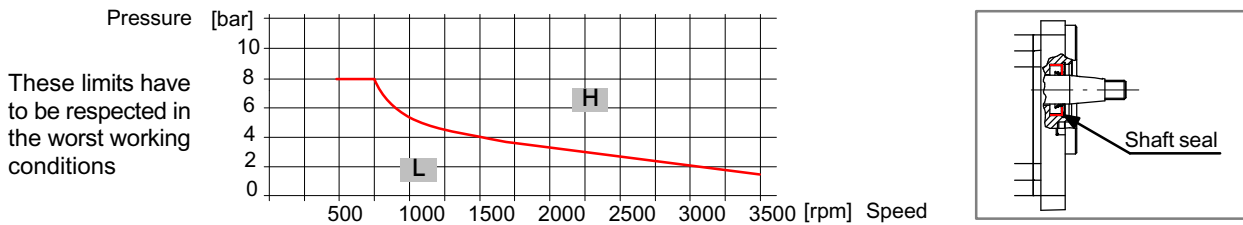

1 Unidirectional motor APM

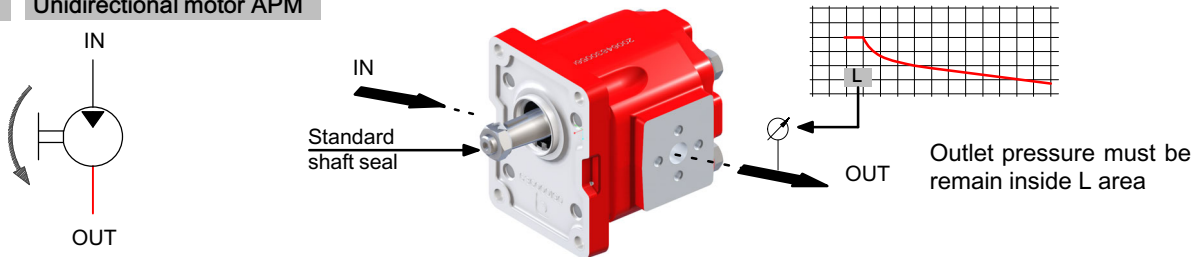

2 Bidirectional motor used in only one direction

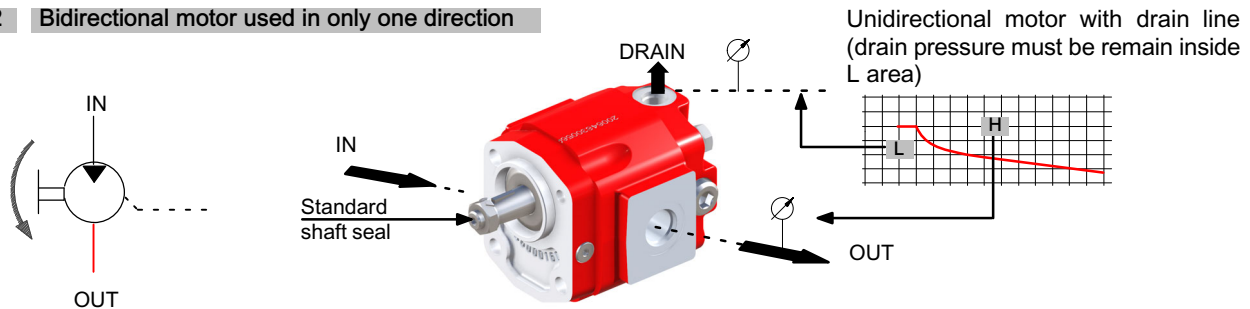

3 Unidirectional motor APM

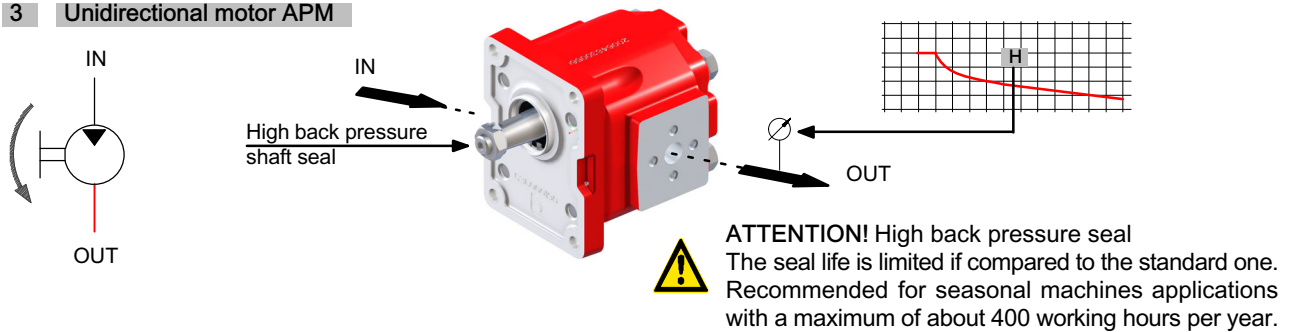

4 Bidirectional motor APMR

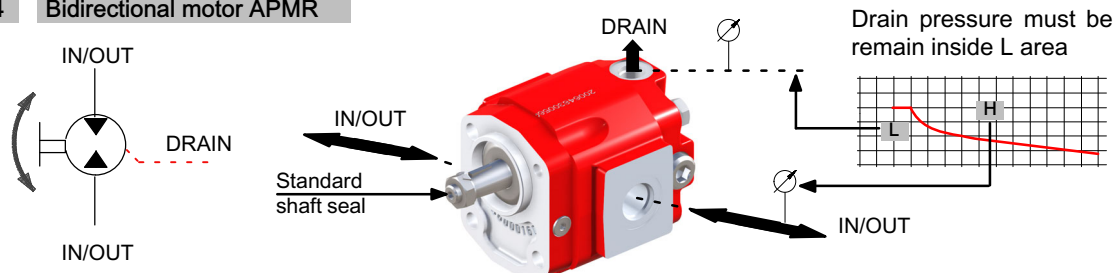

1.10 General installation precaution

In addition to the recommendations regarding fluids, filtration, coupling, etc., we suggest the following:

- For unidirectional motors check always the rotation direction of the motor's take off shaft; it must be compatible with the rotation direction of the motor itself.
- Be particularly careful in cleaning and make sure, when connecting the high and low pressure piping, that no chips, rag threads, teflon tape, etc. get into the motor circulation system.
- Check the tightness of the high and low pressure fittings, the correct positioning of the O-Ring, and make sure there is no dirt between the flange and the motor body.
- To ensure the best heat distribution inside the tank,

make sure the return pipe is not too close to the motor's Outlet piping.

The pipes themselves should be below oil tank level to prevent the formation of foam.

- Do not subject the motors to operating conditions different from those indicated on section 1.2 ; for extreme operations, always contact our Technical Department.
- Never use fluids different from those indicated in section 1.2.
- Ambient temperature range: -20 / +50 °C
- In the event of motor painting, do not use solvents or paints that are incompatible with the material of the seals. Do not bake paint with excessively high temperatures.

Example of several hydraulic circuits available:

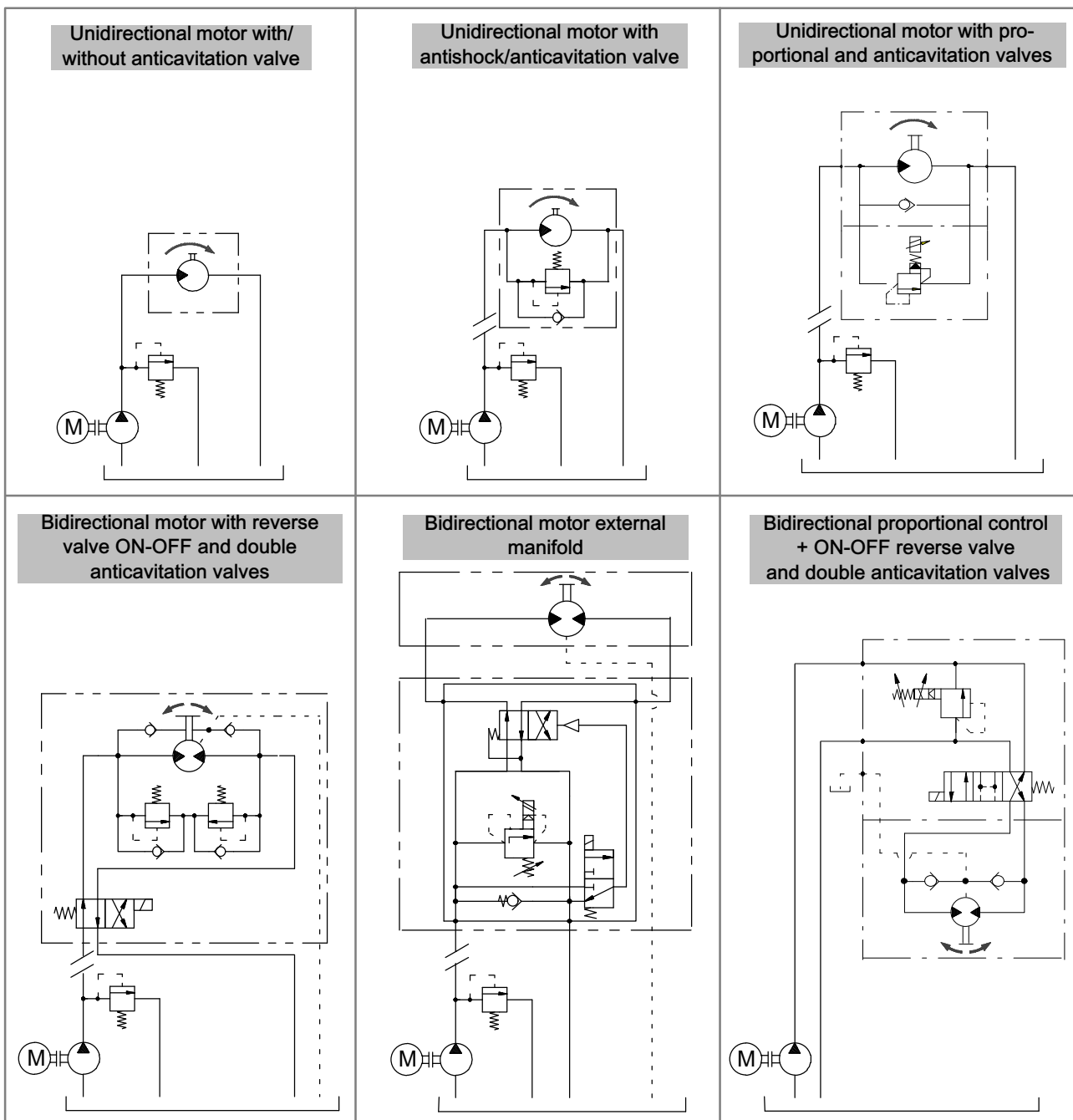

1.11 Directives and standards

- Atex:



Attention: The equipment and protective systems of this catalogue ARE NOT intended for use in potentially explosive atmospheres. Ref: Directive 99/92/EC and Directive 2014/34/EU

- ISO 9001:2015 / ISO 14001:2015

Bucher Hydraulics S.p.A. is certified for research, development and production of directional control valves, power units, gear pumps and motors, electro pumps, cartridge valves and integrated manifolds for hydraulic applications.

1.12 Non-standard symbols used in the text

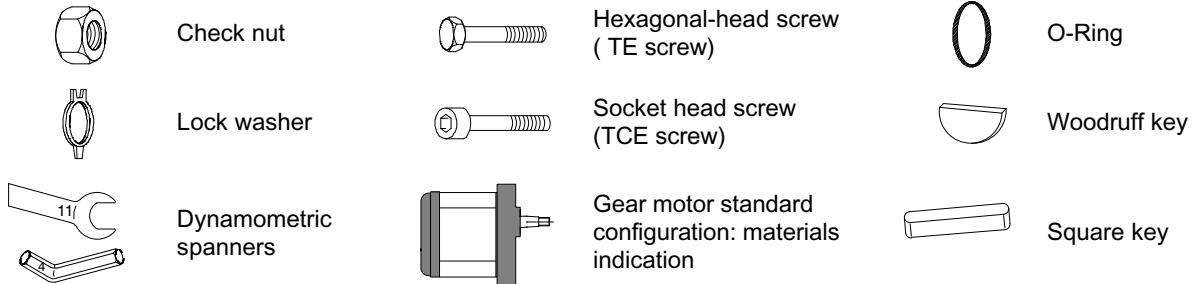

1.13 Gear motor formulas

The following parameters are defined:

V_c = (cm³/r) motor displacement;
n = (r/min) no. of rpm of the outlet shaft;
Q = (l/min) flow rate;
Δp = (bar) P_{IN}-P_{OUT}, operating Δp pressure;
T = (Nm) outlet torque;
N = (kW) outlet power;
η_v = (%) volumetric efficiency;
η_m = (%) mechanical efficiency;
η_t = (%) total efficiency (η_t = η_v · η_m)

1.13.1 Parameter relationships

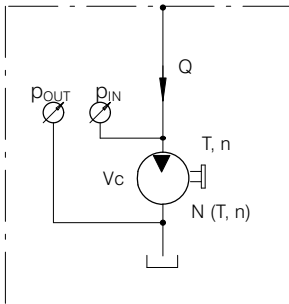
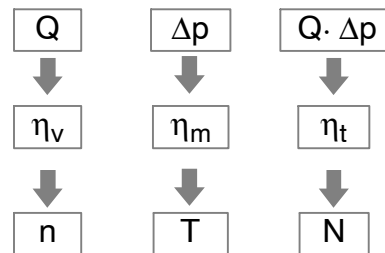

$$Q = \frac{V_c \cdot n}{10 \cdot \eta_v}$$

$$V_c = \frac{10 \cdot Q}{n} \cdot \eta_v$$

$$n = \frac{10 \cdot Q}{V_c} \cdot \eta_v$$

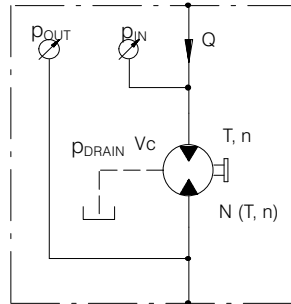

$$\Delta p = \frac{T}{1.592 \cdot V_c \cdot \eta_m} \cdot 10^4$$

$$V_c = \frac{T}{1.592 \cdot \Delta p \cdot \eta_m} \cdot 10^4$$

$$T = 1.592 \cdot V_c \cdot \Delta p \cdot \eta_m \cdot 10^{-4} \quad N = \frac{Q \cdot \Delta p}{6 \cdot 10^4} \cdot \eta_t$$

Example

APM212HP/11 V_c = 11.1 cm³/r Q_{IN} = 18.5 l/min Δp = 200 bar η_v = 90% η_m = 90%

$$n = \frac{10 \cdot 18.5}{11.1} \cdot 90 = 1500 \text{ r/min.}$$

$$\eta_t = 0.90 \cdot 0.90 = 0.81 = 81\%$$

$$N = \frac{18.5 \cdot 200 \cdot 81}{6 \cdot 10^4} = 5.0 \text{ kW}$$

$$T = 1.592 \cdot 11.1 \cdot 200 \cdot 90 \cdot 10^{-4} = 31.8 \text{ Nm}$$

1.14 Diagrams APM212HP

Oil viscosity: 37 mm²/s

Oil temperature: 40°C

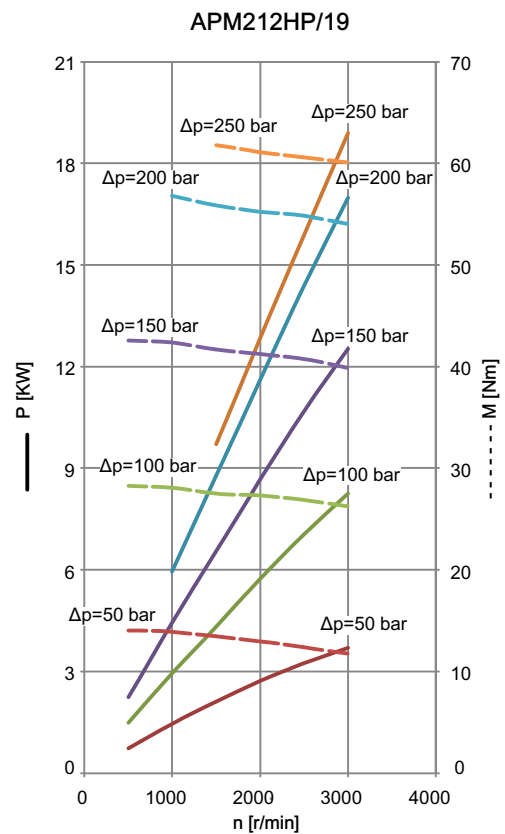
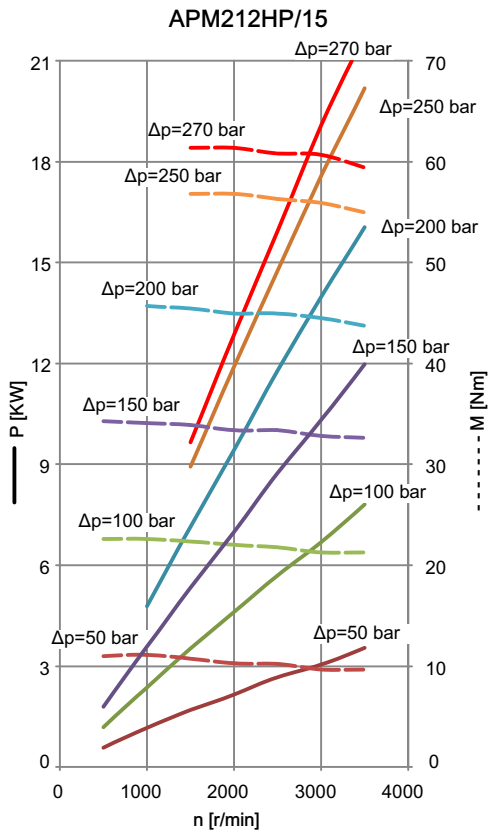
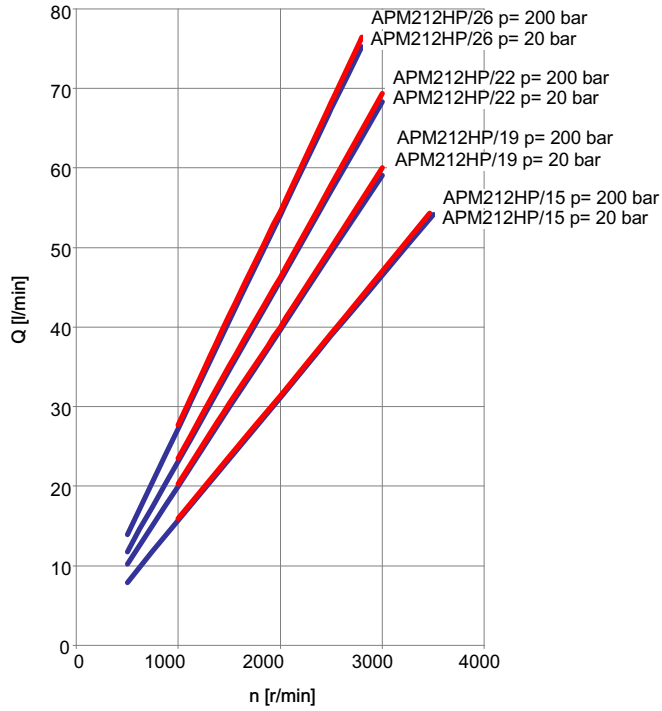

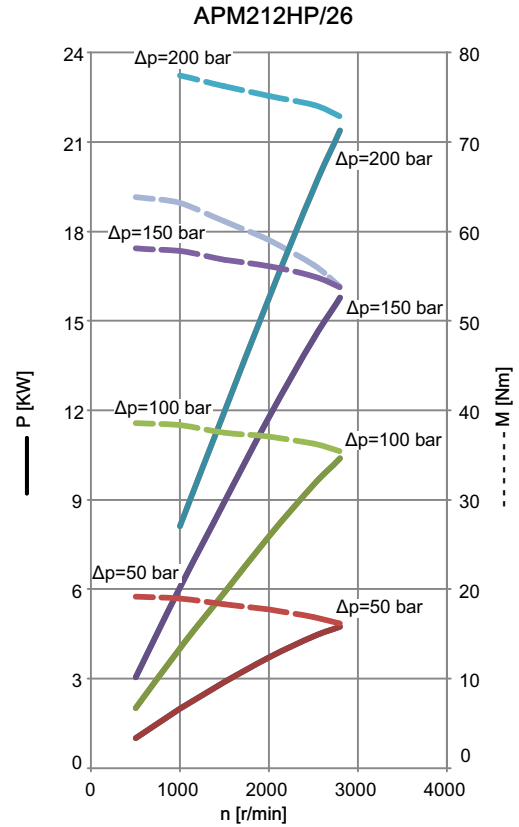
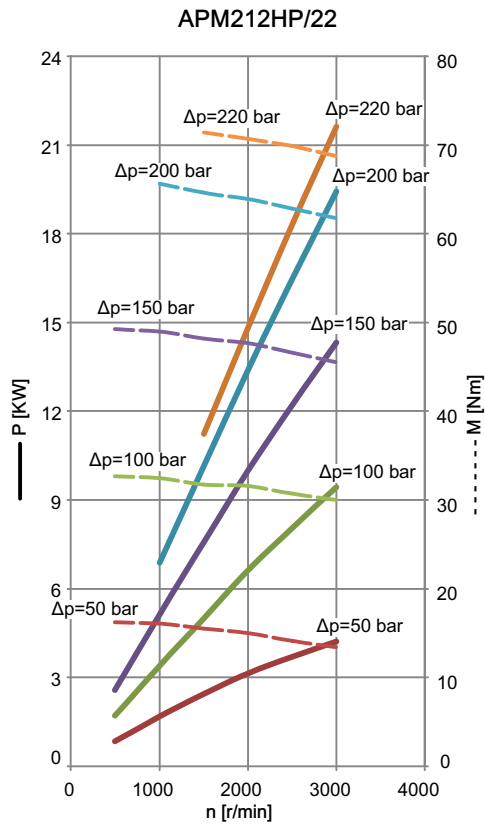

2 Overview standard types

This motors configuration are considered as "standard".

| | | | | | | | |
|------|-----|-----------|----------|--------|-------|-----------|-----|
| 218 | 818 | 225 | 227 | 235 | 245 | 237 | 247 |
| 887S | 880 | 887S-NPTF | 880-NPTF | 287S-B | 280-B | 287S-SAEB | |

Example

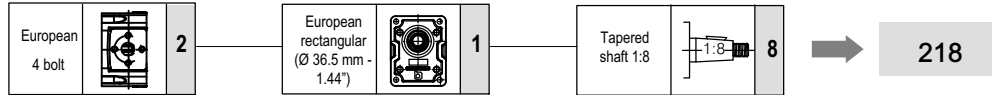

In the next pages, front, rear cover, and seals materials are listed for each motor series.

For ordering purposes, it is enough to outline the complete motor description (for example: APM212HP/15 D 218).

In case of a different configuration request (or a combination of different features, such as port threads, front flange materials, etc.), the description configurator shown in section 3.1 can be easily used.

2.1 Standard configuration

| Port type | | | Front cover type (cast iron made) | | | Drive shaft | | |
|-----------------------------|--|---|--|--|---|---|--|----|
| European 4 bolts flanged | | 2 | European rectangular (Ø 36.5 mm - 1.44") | | 1 | Tapered shaft 1:8 | | 8 |
| German 4 bolts flanged | | 2 | German rectangular (Ø 80 mm - 3.15 inches) | | 2 | Tapered shaft 1:5 | | 5 |
| BSPP Threaded ports | | 8 | Through 2 bolts (Ø 50 mm - 1.97") | | 3 | 9 Teeth external spline B17X14 DIN5482 | | 7 |
| SAE Threaded ports | | 8 | Through 2 bolts (Ø 50 mm - 1.97") | | 4 | 9 teeth external spline SAE J 498-9T 16/32 DP | | 7S |
| NPTF Threaded ports | | 8 | SAE-A 2 bolts (Ø 82.55 mm - 3.25 inches) | | 8 | Straight keyed Ø 15.85 mm - 0.62 inches | | 0 |
| | | | SAE-B 2 bolts (Ø 101,6 mm - 4 inches) | | 8 | | | |

| Serie | page | Serie | page | Serie | page |
|---|------|---|----------|---|----------|
| 218 | 16 | 818 | 17 | 225 | 18 |
|  | |  | |  | |
| 227 | 19 | 235 - 245 | 20 21 | 237 - 247 | 22 23 |
|  | |  | |  | |
| 887S | 24 | 880 | 25 | 887S-NPTF | 26 |
|  | |  | |  | |
| 880-NPTF | 27 | 287S-B | 28 | 280-B | 29 |
|  | |  | |  | |
| 287S-SAEB | 30 | | | | |
|  | | | | | |

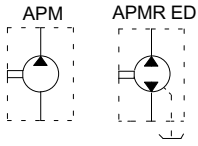

Serie 218

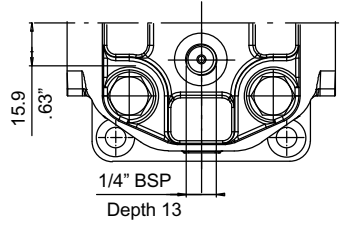
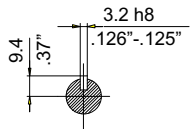
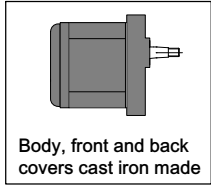
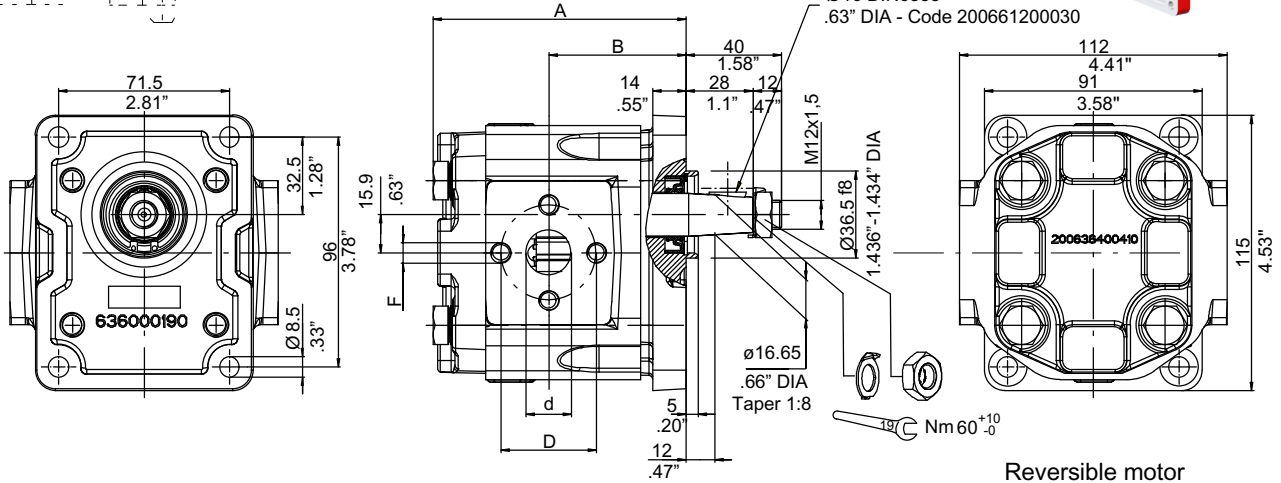
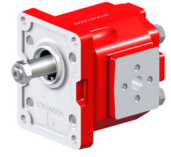

Shaft max torque: see section 3.3
Tightening torque: see section 3.5 - 3.6

| Type | Displacement cm ³ /rev | | Dimensions | | | | Outlet | | | | | Inlet | | | | |
|------|--------------------------------------|------------|---|-----------|---------|-----------|---------|-----------|---------|---------|-------------|---------|-----|----|------|-------------|
| | APM212HP | APM212HPLN | A mm | B inch | B mm | B inch | d mm | D inch | F mm | d mm | D inch | F mm | | | | |
| 15 | 15.1 | 15.7 | 105.6 | 4.16 | 57.3 | 2.26 | 19 | .75 | 40 | 1.58 | M8X 1.25 | 13.5 | .53 | 30 | 1.18 | M6X1 |
| 19 | 19.2 | 19.8 | 111.6 | 4.39 | 60.3 | 2.37 | | | | | | 19 | .75 | 40 | 1.58 | M8X 1.25 |
| 22 | 22.2 | 23 | 116.6 | 4.59 | 62.55 | 2.46 | | | | | | 19 | .75 | 40 | 1.58 | M8X 1.25 |
| 26 | 26.2 | 27.1 | 122.1 | 4.81 | 65.55 | 2.58 | | | | | | 19 | .75 | 40 | 1.58 | M8X 1.25 |
| 29 | 28.9 | 1.764 | Displacements on request: please contact our Sales Department | | | | | | | | | | | | | |
| 33 | 33 | 2.014 | | | | | | | | | | | | | | |

| Clockwise rotation: D | | Counter-clockwise rotation: S | | Reversible motor External Drain | |
|-----------------------|------------------------|-------------------------------|------------------------|---------------------------------|--------------------------|
| Standard | Low Noise | Standard | Low Noise | Standard | Low Noise |
| APM212HP/15 D 218 | APM212HP/15LN D 218 | APM212HP/15 S 218 | APM212HP/15LN S 218 | APMR212HP/15 ED 218 | APMR212HP/15LN ED 218 |
| APM212HP/19 D 218 | APM212HP/19LN D 218 | APM212HP/19 S 218 | APM212HP/19LN S 218 | APMR212HP/19 ED 218 | APMR212HP/19LN ED 218 |
| APM212HP/22 D 218 | APM212HP/22LN D 218 | APM212HP/22 S 218 | APM212HP/22LN S 218 | APMR212HP/22 ED 218 | APMR212HP/22LN ED 218 |
| APM212HP/26 D 218 | APM212HP/26LN D 218 | APM212HP/26 S 218 | APM212HP/26LN S 218 | APMR212HP/26 ED 218 | APMR212HP/26LN ED 218 |

For reversible motors alternative inlet and outlet ports have the same sizes as per inlet unidirectional rotation.

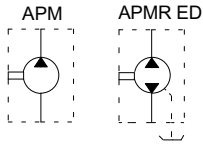

Serie
818

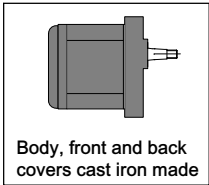
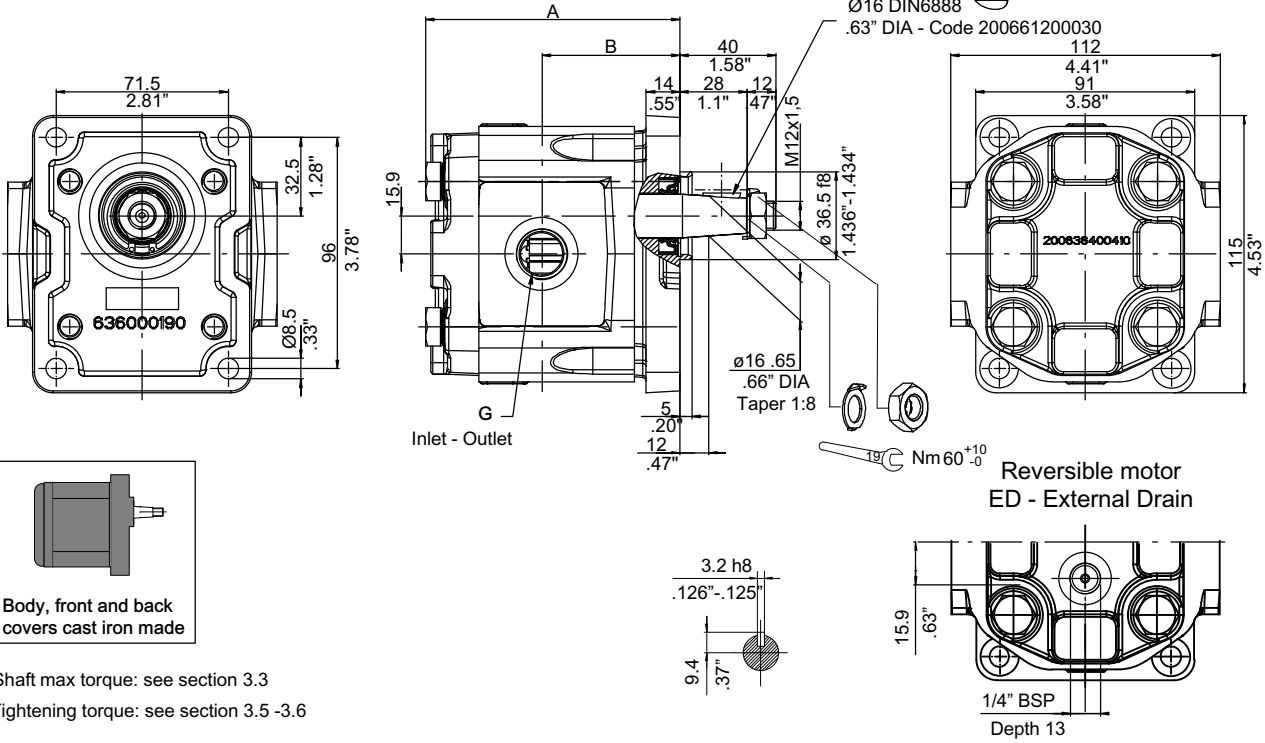

Shaft max torque: see section 3.3
Tightening torque: see section 3.5 - 3.6

| Type | Displacement cm ³ /rev | | Dimensions | | | | Outlet G | Inlet G |
|------|--------------------------------------|------------|---|------|-------|------|-------------|------------|
| | APM212HP | APM212HPLN | A | | B | | | |
| | | | mm | inch | mm | inch | BSP | BSP |
| 15 | 15.1 | 15.7 | 105.6 | 4.16 | 57.3 | 2.26 | 1/2" | 3/8" |
| 19 | 19.2 | 19.8 | 111.6 | 4.39 | 60.3 | 2.37 | 3/4" | 1/2" |
| 22 | 22.2 | 23 | 116.6 | 4.59 | 62.55 | 2.46 | | |
| 26 | 26.2 | 27.1 | 122.1 | 4.81 | 65.55 | 2.58 | | |
| 29 | 28.9 | 1.764 | Displacements on request: please contact our Sales Department | | | | | |
| 33 | 33 | 2.014 | | | | | | |

| Clockwise rotation: D | | Counter-clockwise rotation: S | | Reversible motor External Drain | |
|-----------------------|------------------------|-------------------------------|------------------------|---------------------------------|--------------------------|
| Standard | Low Noise | Standard | Low Noise | Standard | Low Noise |
| APM212HP/15 D 818 | APM212HP/15LN D 818 | APM212HP/15 S 818 | APM212HP/15LN S 818 | APMR212HP/15 ED 818 | APMR212HP/15LN ED 818 |
| APM212HP/19 D 818 | APM212HP/19LN D 818 | APM212HP/19 S 818 | APM212HP/19LN S 818 | APMR212HP/19 ED 818 | APMR212HP/19LN ED 818 |
| APM212HP/22 D 818 | APM212HP/22LN D 818 | APM212HP/22 S 818 | APM212HP/22LN S 818 | APMR212HP/22 ED 818 | APMR212HP/22LN ED 818 |
| APM212HP/26 D 818 | APM212HP/26LN D 818 | APM212HP/26 S 818 | APM212HP/26LN S 818 | APMR212HP/26 ED 818 | APMR212HP/26LN ED 818 |

For reversible motors alternative inlet and outlet ports have the same sizes as per inlet unidirectional rotation.

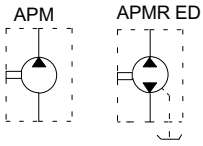

Serie
225

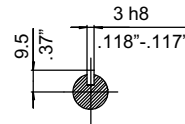
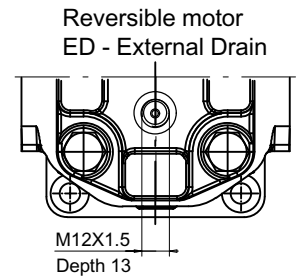
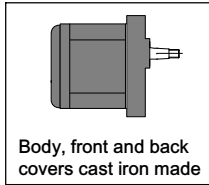
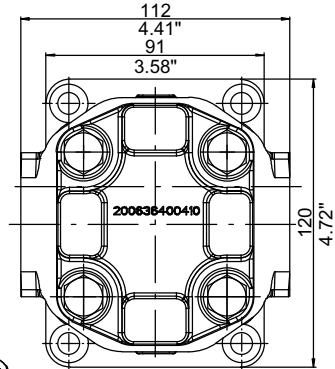
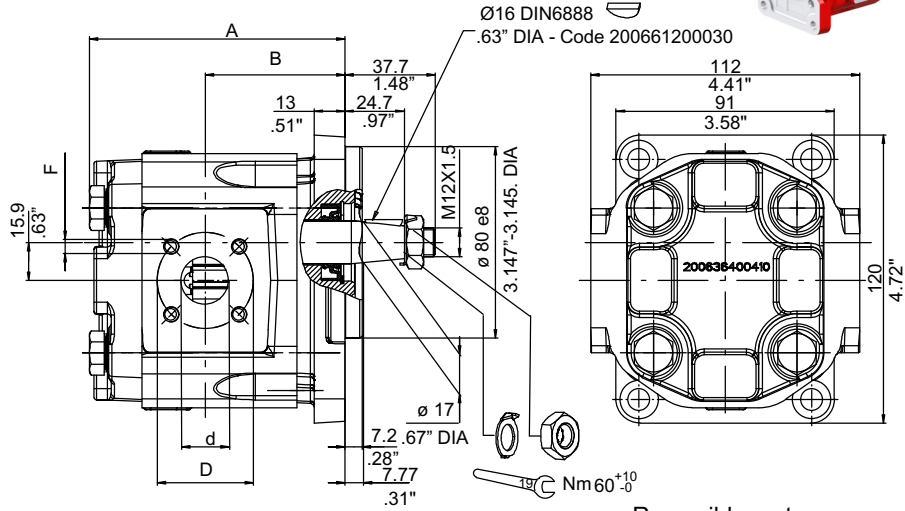
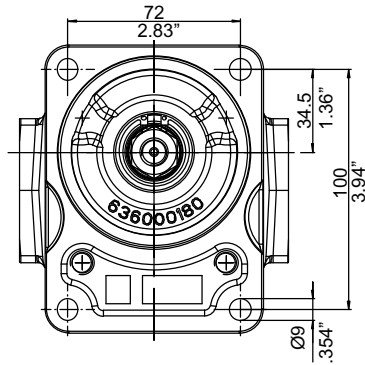

Shaft max torque: see section 3.3
Tightening torque: see section 3.5 - 3.6

| Type | Displacement cm ³ /rev | | Dimensions | | | | Outlet | | | Inlet | | | | | | |
|------|--------------------------------------|------------|---|------|-------|------|--------|------|----|-------|----------|------|-----|----|------|----------|
| | APM212HP | APM212HPLN | A | B | d | D | F | d | D | F | | | | | | |
| | | | mm | inch | mm | inch | mm | inch | mm | inch | mm | inch | mm | | | |
| 15 | 15.1 | 15.7 | 106.6 | 4.20 | 58.3 | 2.30 | | | | | | | | | | |
| 19 | 19.2 | 19.8 | 112.6 | 4.43 | 61.3 | 2.41 | 20 | .79 | 40 | 1.58 | M6 x1 | 15 | .59 | 35 | 1.38 | M6 x1 |
| 22 | 22.2 | 23 | 117.1 | 4.61 | 63.55 | 2.50 | | | | | | | | | | |
| 26 | 26.2 | 27.1 | 123.1 | 4.85 | 66.55 | 2.62 | | | | | | | | | | |
| 29 | 28.9 | 1.764 | Displacements on request: please contact our Sales Department | | | | | | | | | | | | | |
| 33 | 33 | 2.014 | | | | | | | | | | | | | | |

| Clockwise rotation: D | | Counter-clockwise rotation: S | | Reversible motor External Drain | |
|-----------------------|------------------------|-------------------------------|------------------------|---------------------------------|--------------------------|
| Standard | Low Noise | Standard | Low Noise | Standard | Low Noise |
| APM212HP/15 D 225 | APM212HP/15LN D 225 | APM212HP/15 S 225 | APM212HP/15LN S 225 | APMR212HP/15 ED 225 | APMR212HP/15LN ED 225 |
| APM212HP/19 D 225 | APM212HP/19LN D 225 | APM212HP/19 S 225 | APM212HP/19LN S 225 | APMR212HP/19 ED 225 | APMR212HP/19LN ED 225 |
| APM212HP/22 D 225 | APM212HP/22LN D 225 | APM212HP/22 S 225 | APM212HP/22LN S 225 | APMR212HP/22 ED 225 | APMR212HP/22LN ED 225 |
| APM212HP/26 D 225 | APM212HP/26LN D 225 | APM212HP/26 S 225 | APM212HP/26LN S 225 | APMR212HP/26 ED 225 | APMR212HP/26LN ED 225 |

For reversible motors alternative inlet and outlet ports have the same sizes as per inlet unidirectional rotation.

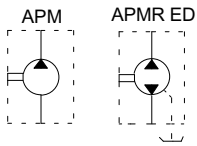

Serie
227

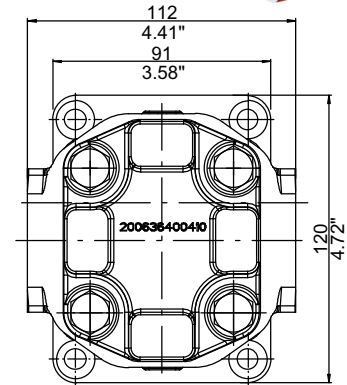
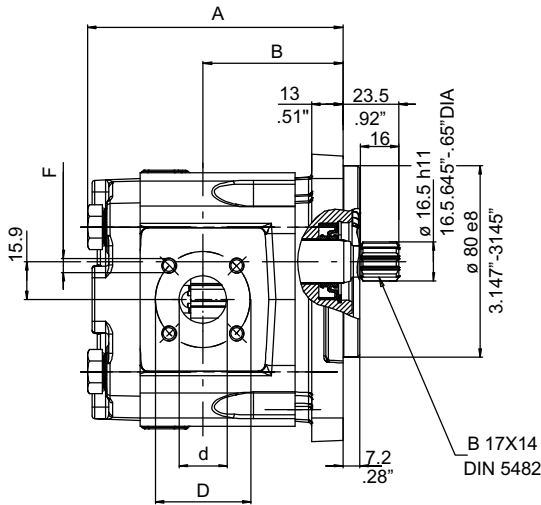
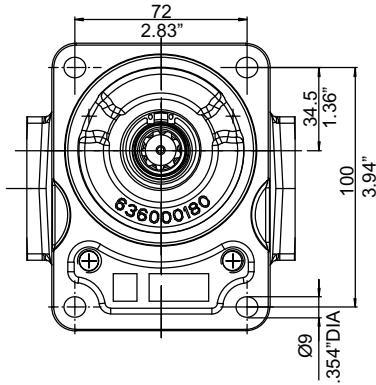

Reversible motor
ED - External Drain

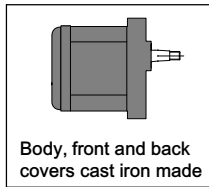
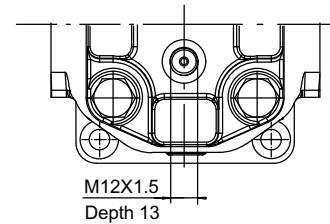

Shaft max torque: see section 3.3

Tightening torque: see section 3.5 - 3.6

| Type | Displacement cm ³ /rev | | Dimensions | | | | Outlet | | | | | Inlet | | | | |
|------|--------------------------------------|------------|---|------|-------|------|--------|------|----|------|----------|-------|-----|------|------|----------|
| | APM212HP | APM212HPLN | A | B | d | D | F | d | D | F | d | D | F | | | |
| | | | mm | inch | mm | inch | mm | inch | mm | inch | mm | inch | mm | inch | mm | |
| 15 | 15.1 | 15.7 | 106.6 | 4.20 | 58.3 | 2.30 | | | | | | | | | | |
| 19 | 19.2 | 19.8 | 112.6 | 4.43 | 61.3 | 2.41 | 20 | .79 | 40 | 1.58 | M6 x1 | 15 | .59 | 35 | 1.38 | M6 x1 |
| 22 | 22.2 | 23 | 117.1 | 4.61 | 63.55 | 2.50 | | | | | | | | | | |
| 26 | 26.2 | 27.1 | 123.1 | 4.85 | 66.55 | 2.62 | | | | | | | | | | |
| 29 | 28.9 | 1.764 | Displacements on request: please contact our Sales Department | | | | | | | | | | | | | |
| 33 | 33 | 2.014 | | | | | | | | | | | | | | |

| Clockwise rotation: D | | Counter-clockwise rotation: S | | Reversible motor External Drain | |
|-----------------------|------------------------|-------------------------------|------------------------|---------------------------------|--------------------------|
| Standard | Low Noise | Standard | Low Noise | Standard | Low Noise |
| APM212HP/15 D 227 | APM212HP/15LN D 227 | APM212HP/15 S 227 | APM212HP/15LN S 227 | APMR212HP/15 ED 227 | APMR212HP/15LN ED 227 |
| APM212HP/19 D 227 | APM212HP/19LN D 227 | APM212HP/19 S 227 | APM212HP/19LN S 227 | APMR212HP/19 ED 227 | APMR212HP/19LN ED 227 |
| APM212HP/22 D 227 | APM212HP/22LN D 227 | APM212HP/22 S 227 | APM212HP/22LN S 227 | APMR212HP/22 ED 227 | APMR212HP/22LN ED 227 |
| APM212HP/26 D 227 | APM212HP/26LN D 227 | APM212HP/26 S 227 | APM212HP/26LN S 227 | APMR212HP/26 ED 227 | APMR212HP/26LN ED 227 |

For reversible motors alternative inlet and outlet ports have the same sizes as per inlet unidirectional rotation.

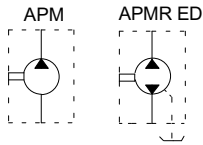

Serie
235

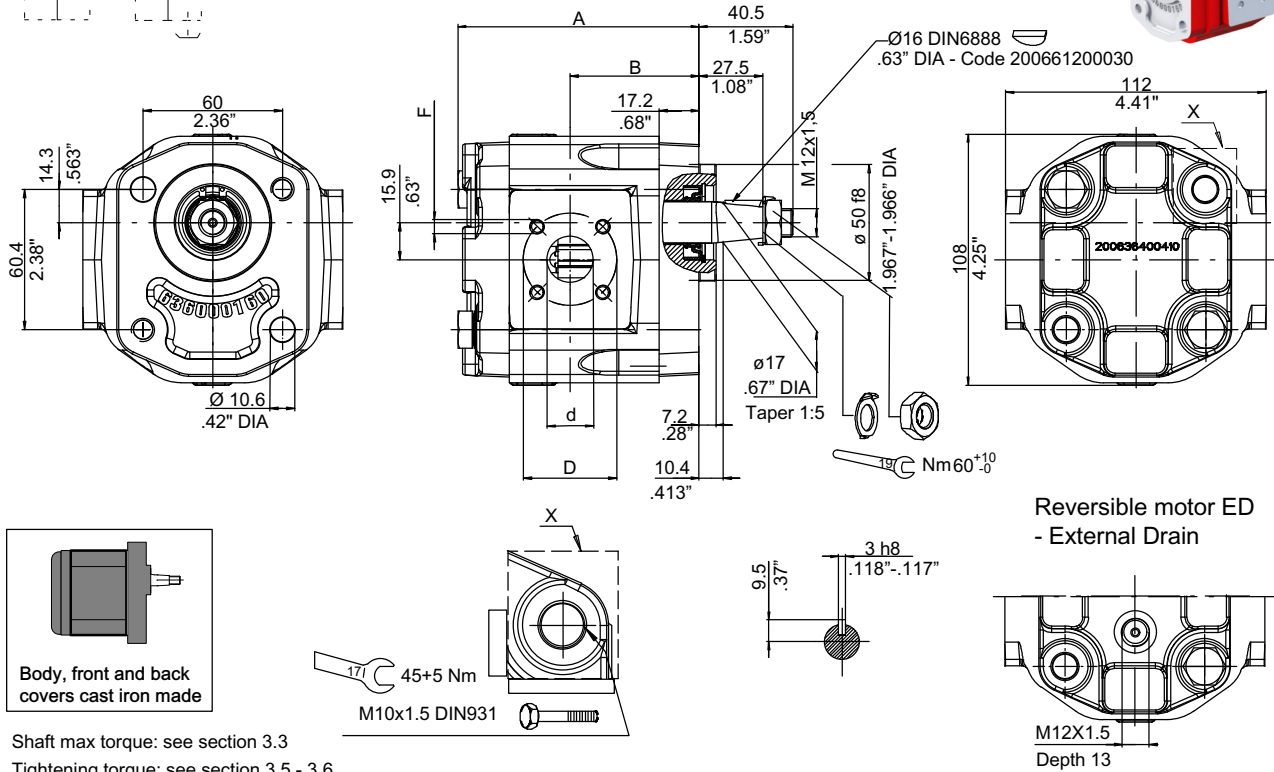

Reversible motor ED
- External Drain

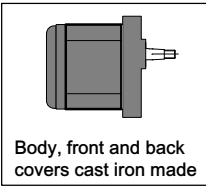

Shaft max torque: see section 3.3
Tightening torque: see section 3.5 - 3.6

| Type | Displacement cm ³ /rev | | Dimensions | | | | Outlet | | | | | Inlet | | | | |
|------|--------------------------------------|------------|---|------|-------|------|--------|-----|----|------|----------|-------|-----|----|------|----------|
| | APM212HP | APM212HPLN | A | B | d | D | F | d | D | F | d | D | F | | | |
| 15 | 15.1 | 15.7 | 103.8 | 4.09 | 55.5 | 2.19 | 20 | .79 | 40 | 1.58 | M6 x1 | 15 | .59 | 35 | 1.38 | M6 x1 |
| 19 | 19.2 | 19.8 | 109.8 | 4.32 | 58.5 | 2.30 | | | | | | | | | | |
| 22 | 22.2 | 23 | 114.3 | 4.5 | 60.75 | 2.39 | | | | | | | | | | |
| 26 | 26.2 | 27.1 | 120.3 | 4.74 | 63.75 | 2.51 | | | | | | | | | | |
| 29 | 28.9 | 1.764 | Displacements on request: please contact our Sales Department | | | | | | | | | | | | | |
| 33 | 33 | 2.014 | | | | | | | | | | | | | | |

| Clockwise rotation: D | | Counter-clockwise rotation: S | | Reversible motor External Drain | |
|-----------------------|------------------------|-------------------------------|------------------------|---------------------------------|--------------------------|
| Standard | Low Noise | Standard | Low Noise | Standard | Low Noise |
| APM212HP/15 D 235 | APM212HP/15LN D 235 | APM212HP/15 S 235 | APM212HP/15LN S 235 | APMR212HP/15 ED 235 | APMR212HP/15LN ED 235 |
| APM212HP/19 D 235 | APM212HP/19LN D 235 | APM212HP/19 S 235 | APM212HP/19LN S 235 | APMR212HP/19 ED 235 | APMR212HP/19LN ED 235 |
| APM212HP/22 D 235 | APM212HP/22LN D 235 | APM212HP/22 S 235 | APM212HP/22LN S 235 | APMR212HP/22 ED 235 | APMR212HP/22LN ED 235 |
| APM212HP/26 D 235 | APM212HP/26LN D 235 | APM212HP/26 S 235 | APM212HP/26LN S 235 | APMR212HP/26 ED 235 | APMR212HP/26LN ED 235 |

For reversible motors alternative inlet and outlet ports have the same sizes as per inlet unidirectional rotation.

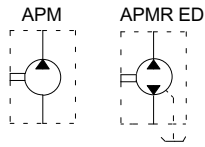

Serie
245

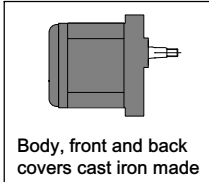
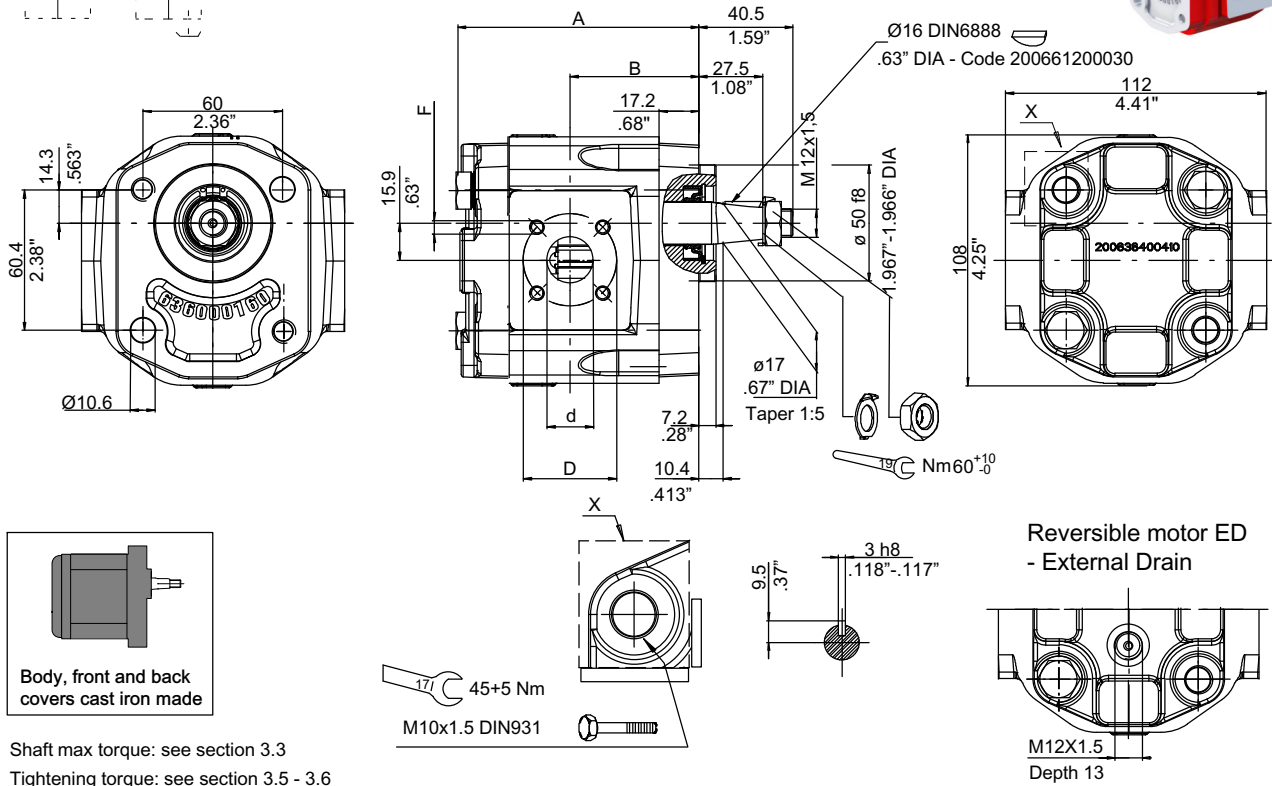

Shaft max torque: see section 3.3
Tightening torque: see section 3.5 - 3.6

| Type | Displacement cm ³ /rev | | Dimensions | | | | Outlet | | | Inlet | | | | | | |
|------|--------------------------------------|------------|---|------|-------|------|--------|------|----|-------|------|------|-----|----|------|------|
| | APM212HP | APM212HPLN | A | B | d | D | F | d | D | F | | | | | | |
| | | | mm | inch | mm | inch | mm | inch | mm | inch | mm | inch | mm | | | |
| 15 | 15.1 | 15.7 | 103.8 | 4.09 | 55.5 | 2.19 | 20 | .79 | 40 | 1.58 | M6X1 | 15 | .59 | 35 | 1.38 | M6X1 |
| 19 | 19.2 | 19.8 | 109.8 | 4.32 | 58.5 | 2.30 | | | | | | | | | | |
| 22 | 22.2 | 23 | 114.3 | 4.5 | 60.75 | 2.39 | | | | | | | | | | |
| 26 | 26.2 | 27.1 | 120.3 | 4.74 | 63.75 | 2.51 | | | | | | | | | | |
| 29 | 28.9 | 1.764 | Displacements on request: please contact our Sales Department | | | | | | | | | | | | | |
| 33 | 33 | 2.014 | | | | | | | | | | | | | | |

| Clockwise rotation: D | | Counter-clockwise rotation: S | | Reversible motor External Drain | |
|-----------------------|------------------------|-------------------------------|------------------------|---------------------------------|--------------------------|
| Standard | Low Noise | Standard | Low Noise | Standard | Low Noise |
| APM212HP/15 D 245 | APM212HP/15LN D 245 | APM212HP/15 S 245 | APM212HP/15LN S 245 | APMR212HP/15 ED 245 | APMR212HP/15LN ED 245 |
| APM212HP/19 D 245 | APM212HP/19LN D 245 | APM212HP/19 S 245 | APM212HP/19LN S 245 | APMR212HP/19 ED 245 | APMR212HP/19LN ED 245 |
| APM212HP/22 D 245 | APM212HP/22LN D 245 | APM212HP/22 S 245 | APM212HP/22LN S 245 | APMR212HP/22 ED 245 | APMR212HP/22LN ED 245 |
| APM212HP/26 D 245 | APM212HP/26LN D 245 | APM212HP/26 S 245 | APM212HP/26LN S 245 | APMR212HP/26 ED 245 | APMR212HP/26LN ED 245 |

For reversible motors alternative inlet and outlet ports have the same sizes as per inlet unidirectional rotation.

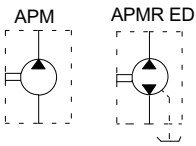

Serie
237

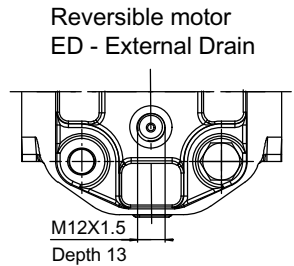
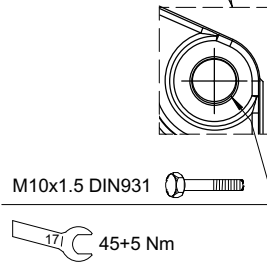
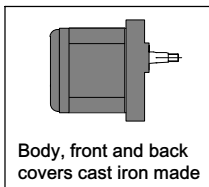
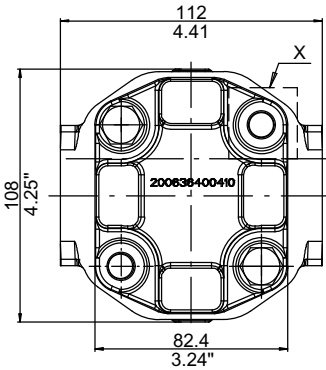
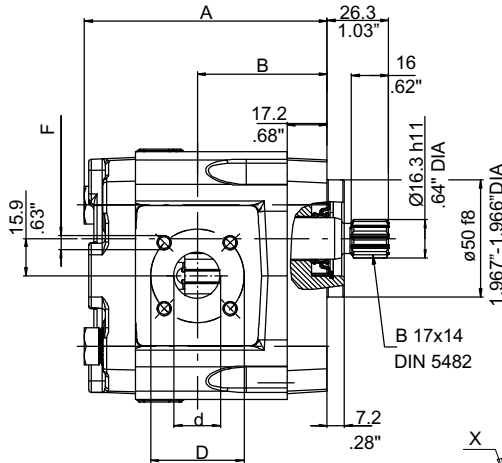
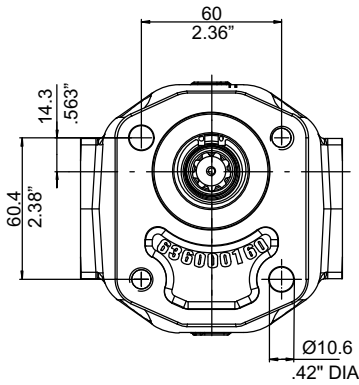

Shaft max torque: see section 3.3
Tightening torque: see section 3.5 - 3.6

| Type | Displacement cm ³ /rev | | Dimensions | | | | Outlet | | | Inlet | | | | | | |
|------|--------------------------------------|------------|---|------|-------|------|--------|------|----|-------|------|------|-----|------|------|------|
| | APM212HP | APM212HPLN | A | | B | | d | | D | F | d | | D | | F | |
| | | | mm | inch | mm | inch | mm | inch | mm | inch | mm | inch | mm | inch | mm | |
| 15 | 15.1 | 15.7 | 103.8 | 4.09 | 55.5 | 2.19 | 20 | .79 | 40 | 1.58 | M6X1 | 15 | .59 | 35 | 1.38 | M6X1 |
| 19 | 19.2 | 19.8 | 109.8 | 4.32 | 58.5 | 2.30 | | | | | | | | | | |
| 22 | 22.2 | 23 | 114.3 | 4.5 | 60.75 | 2.39 | | | | | | | | | | |
| 26 | 26.2 | 27.1 | 120.3 | 4.74 | 63.75 | 2.51 | | | | | | | | | | |
| 29 | 28.9 | 1.764 | Displacements on request: please contact our Sales Department | | | | | | | | | | | | | |
| 33 | 33 | 2.014 | | | | | | | | | | | | | | |

| Clockwise rotation: D | | Counter-clockwise rotation: S | | Reversible motor External Drain | |
|-----------------------|------------------------|-------------------------------|------------------------|---------------------------------|--------------------------|
| Standard | Low Noise | Standard | Low Noise | Standard | Low Noise |
| APM212HP/15 D 237 | APM212HP/15LN D 237 | APM212HP/15 S 237 | APM212HP/15LN S 237 | APMR212HP/15 ED 237 | APMR212HP/15LN ED 237 |
| APM212HP/19 D 237 | APM212HP/19LN D 237 | APM212HP/19 S 237 | APM212HP/19LN S 237 | APMR212HP/19 ED 237 | APMR212HP/19LN ED 237 |
| APM212HP/22 D 237 | APM212HP/22LN D 237 | APM212HP/22 S 237 | APM212HP/22LN S 237 | APMR212HP/22 ED 237 | APMR212HP/22LN ED 237 |
| APM212HP/26 D 237 | APM212HP/26LN D 237 | APM212HP/26 S 237 | APM212HP/26LN S 237 | APMR212HP/26 ED 237 | APMR212HP/26LN ED 237 |

For reversible motors alternative inlet and outlet ports have the same sizes as per inlet unidirectional rotation.

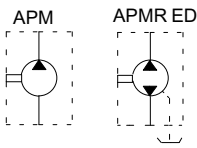

Serie
247

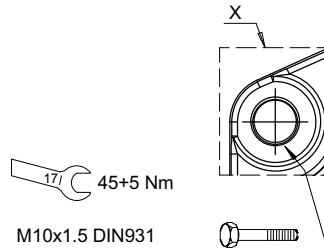
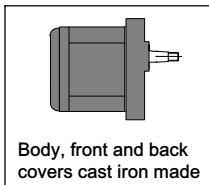
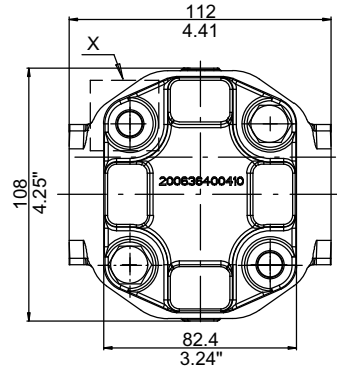
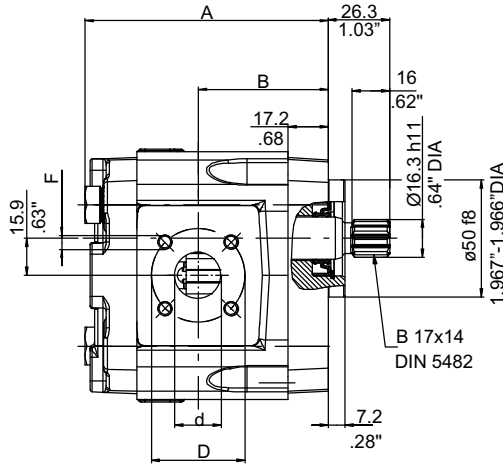
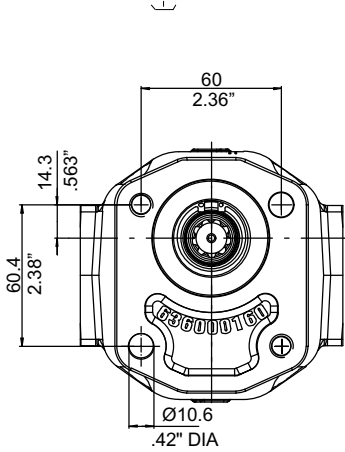

Reversible motor
ED - External Drain

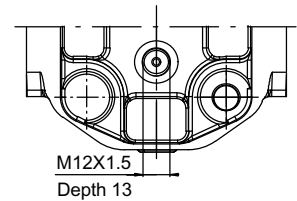

Shaft max torque: see section 3.3
Tightening torque: see section 3.5 - 3.6

| Type | Displacement cm ³ /rev | | Dimensions | | | | Outlet | | | Inlet | | | | | | |
|------|--------------------------------------|------------|---|------|-------|------|--------|------|----|-------|------|------|-----|----|------|------|
| | APM212HP | APM212HPLN | A | B | d | D | F | d | D | F | | | | | | |
| | | | mm | inch | mm | inch | mm | inch | mm | inch | mm | inch | mm | | | |
| 15 | 15.1 | 15.7 | 103.8 | 4.09 | 55.5 | 2.19 | 20 | .79 | 40 | 1.58 | M6X1 | 15 | .59 | 35 | 1.38 | M6X1 |
| 19 | 19.2 | 19.8 | 109.8 | 4.32 | 58.5 | 2.30 | | | | | | | | | | |
| 22 | 22.2 | 23 | 114.3 | 4.5 | 60.75 | 2.39 | | | | | | | | | | |
| 26 | 26.2 | 27.1 | 120.3 | 4.74 | 63.75 | 2.51 | | | | | | | | | | |
| 29 | 28.9 | 1.764 | Displacements on request: please contact our Sales Department | | | | | | | | | | | | | |
| 33 | 33 | 2.014 | | | | | | | | | | | | | | |

| Clockwise rotation: D | | Counter-clockwise rotation: S | | Reversible motor External Drain | |
|-----------------------|------------------------|-------------------------------|------------------------|---------------------------------|--------------------------|
| Standard | Low Noise | Standard | Low Noise | Standard | Low Noise |
| APM212HP/15 D 247 | APM212HP/15LN D 247 | APM212HP/15 S 247 | APM212HP/15LN S 247 | APMR212HP/15 ED 247 | APMR212HP/15LN ED 247 |
| APM212HP/19 D 247 | APM212HP/19LN D 247 | APM212HP/19 S 247 | APM212HP/19LN S 247 | APMR212HP/19 ED 247 | APMR212HP/19LN ED 247 |
| APM212HP/22 D 247 | APM212HP/22LN D 247 | APM212HP/22 S 247 | APM212HP/22LN S 247 | APMR212HP/22 ED 247 | APMR212HP/22LN ED 247 |
| APM212HP/26 D 247 | APM212HP/26LN D 247 | APM212HP/26 S 247 | APM212HP/26LN S 247 | APMR212HP/26 ED 247 | APMR212HP/26LN ED 247 |

For reversible motors alternative inlet and outlet ports have the same sizes as per inlet unidirectional rotation.

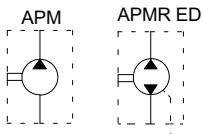

Serie
887S

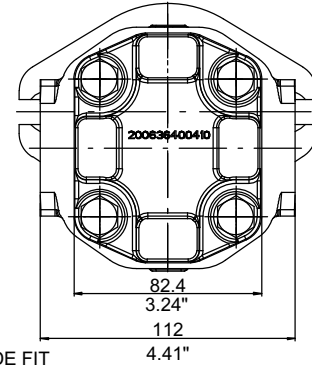
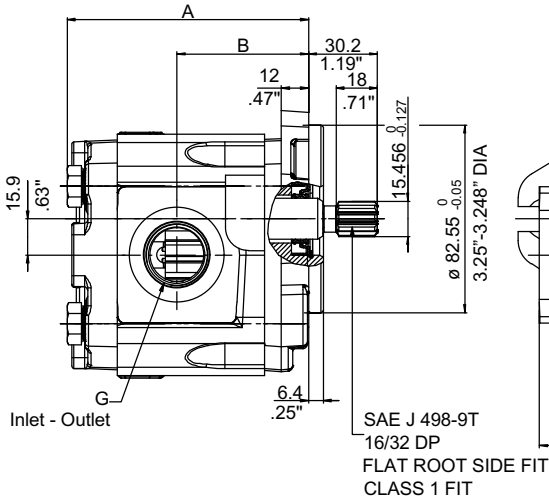
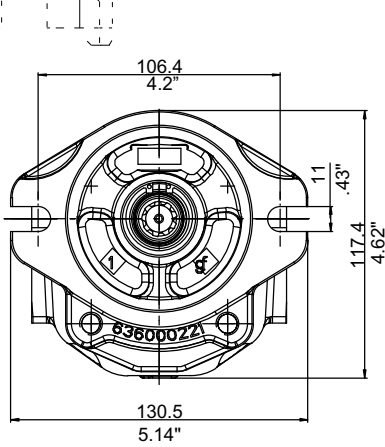

Reversible motor
ED - External Drain

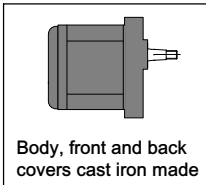
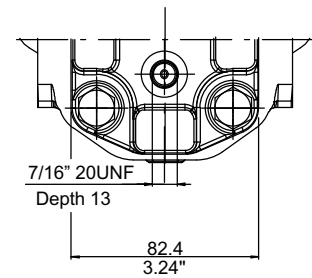

Shaft max torque: see section 3.3
Tightening torque: see section 3.5 - 3.6

| Type | Displacement cm ³ /rev | | Dimensions | | | | Outlet G UNF-2B | Inlet G UNF-2B |
|------|--------------------------------------|------------|---|------|-------|------|-----------------------|----------------------|
| | APM212HP | APM212HPLN | A | | B | | | |
| | | | mm | inch | mm | inch | | |
| 15 | 15.1 | 15.7 | 104.5 | 4.11 | 56.3 | 2.21 | 1-1/16" 12 (SAE12) | 7/8" 14 (SAE10) |
| 19 | 19.2 | 19.8 | 110.5 | 4.35 | 59.3 | 2.33 | | |
| 22 | 22.2 | 23 | 115 | 4.52 | 61.55 | 2.42 | | |
| 26 | 26.2 | 27.1 | 121 | 4.76 | 64.55 | 2.54 | | |
| 29 | 28.9 | 1.764 | Displacements on request: please contact our Sales Department | | | | | |
| 33 | 33 | 2.014 | | | | | | |

| Clockwise rotation: D | | Counter-clockwise rotation: S | | Reversible motor External Drain | |
|------------------------|--------------------------|-------------------------------|--------------------------|---------------------------------|----------------------------|
| Standard | Low Noise | Standard | Low Noise | Standard | Low Noise |
| APM212HP/4.5 D 887S | APM212HP/4.5LN D 887S | APM212HP/4.5 S 887S | APM212HP/4.5LN S 887S | APMR212HP/4.5 ED 887S | APMR212HP/4.5LN ED 887S |
| APM212HP/19 D 887S | APM212HP/19LN D 887S | APM212HP/19 S 887S | APM212HP/19LN S 887S | APMR212HP/19 ED 887S | APMR212HP/19LN ED 887S |
| APM212HP/22 D 887S | APM212HP/22LN D 887S | APM212HP/22 S 887S | APM212HP/22LN S 887S | APMR212HP/22 ED 887S | APMR212HP/22LN ED 887S |
| APM212HP/26 D 887S | APM212HP/26LN D 887S | APM212HP/26 S 887S | APM212HP/26LN S 887S | APMR212HP/26 ED 887S | APMR212HP/26LN ED 887S |

For reversible motors alternative inlet and outlet ports have the same sizes as per inlet unidirectional rotation.

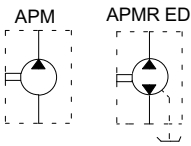

Serie
880

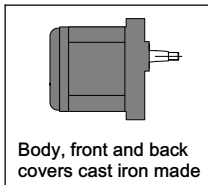
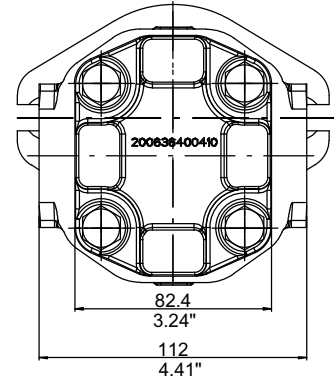
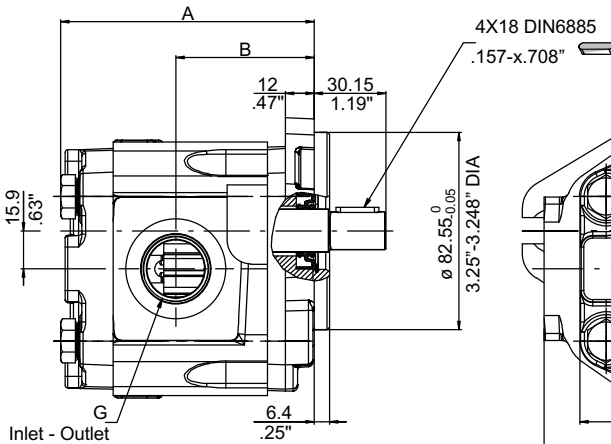
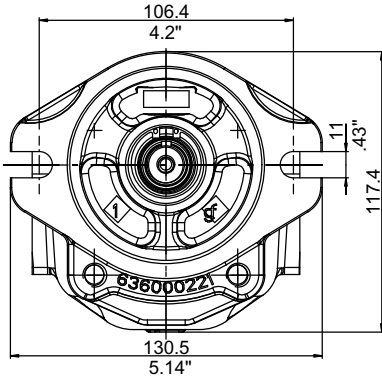

Reversible motor
ED - External Drain

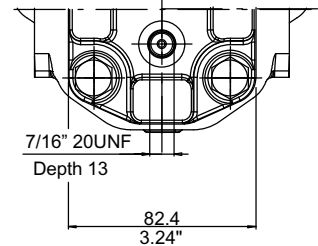
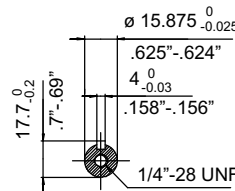

Shaft max torque: see section 3.3

Tightening torque: see section 3.5 - 3.6

| Type | Displacement cm ³ /rev | | Dimensions | | | | Outlet | Inlet |
|------|--------------------------------------|------------|---|------|-------|------|-----------------------|--------------------|
| | APM212HP | APM212HPLN | A | | B | | G | G |
| | | | mm | inch | mm | inch | UNF-2B | UNF-2B |
| 15 | 15.1 | 15.7 | 104.5 | 4.11 | 56.3 | 2.21 | 1-1/16" 12 (SAE12) | 7/8" 14 (SAE10) |
| 19 | 19.2 | 19.8 | 110.5 | 4.35 | 59.3 | 2.33 | | |
| 22 | 22.2 | 23 | 115 | 4.52 | 61.55 | 2.42 | | |
| 26 | 26.2 | 27.1 | 121 | 4.76 | 64.55 | 2.54 | | |
| 29 | 28.9 | 1.764 | Displacements on request: please contact our Sales Department | | | | | |
| 33 | 33 | 2.014 | | | | | | |

| Clockwise rotation: D | | Counter-clockwise rotation: S | | Reversible motor External Drain | |
|-----------------------|------------------------|-------------------------------|------------------------|---------------------------------|--------------------------|
| Standard | Low Noise | Standard | Low Noise | Standard | Low Noise |
| APM212HP/15 D 880 | APM212HP/15LN D 880 | APM212HP/15 S 880 | APM212HP/15LN S 880 | APMR212HP/15 ED 880 | APMR212HP/15LN ED 880 |
| APM212HP/19 D 880 | APM212HP/19LN D 880 | APM212HP/19 S 880 | APM212HP/19LN S 880 | APMR212HP/19 ED 880 | APMR212HP/19LN ED 880 |
| APM212HP/22 D 880 | APM212HP/22LN D 880 | APM212HP/22 S 880 | APM212HP/22LN S 880 | APMR212HP/22 ED 880 | APMR212HP/22LN ED 880 |
| APM212HP/26 D 880 | APM212HP/26LN D 880 | APM212HP/26 S 880 | APM212HP/26LN S 880 | APMR212HP/26 ED 880 | APMR212HP/26LN ED 880 |

For reversible motors alternative inlet and outlet ports have the same sizes as per inlet unidirectional rotation.

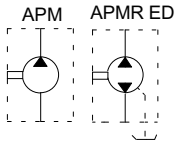

Serie 887S-NPTF

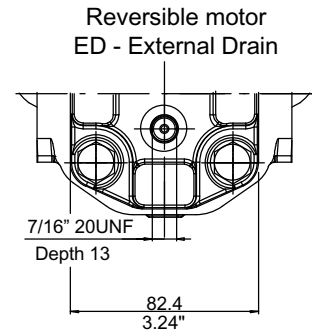
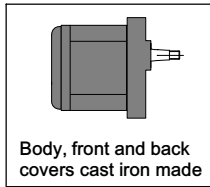
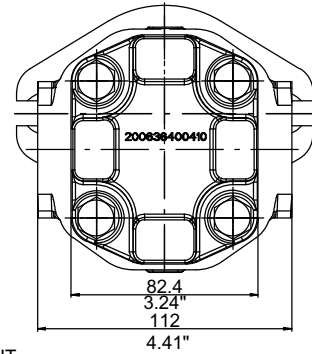
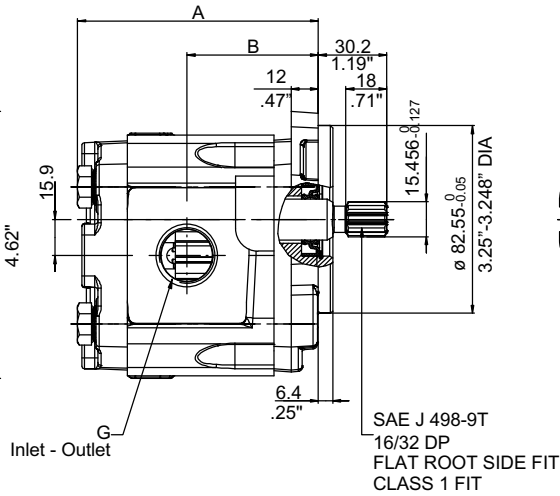
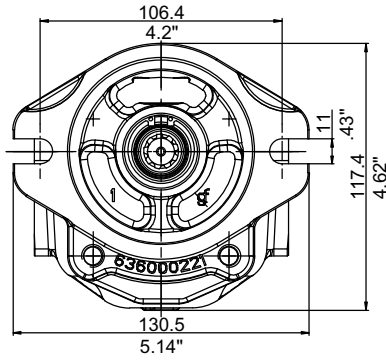
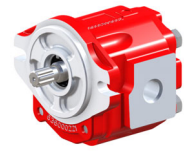

Shaft max torque: see section 3.3
Tightening torque: see section 3.5 - 3.6

| Type | Displacement cm ³ /rev | | Dimensions | | | | Outlet G UNF-2B | Inlet G UNF-2B |
|------|--------------------------------------|------------|------------|------|-------|------|---|----------------------|
| | APM212HP | APM212HPLN | A | | B | | | |
| | | | mm | inch | mm | inch | | |
| 15 | 15.1 | 15.7 | 104.5 | 4.11 | 56.3 | 2.21 | 1-1/16" 12 (SAE12) | 7/8" 14 (SAE10) |
| 19 | 19.2 | 19.8 | 110.5 | 4.35 | 59.3 | 2.33 | | |
| 22 | 22.2 | 23 | 115 | 4.52 | 61.55 | 2.42 | | |
| 26 | 26.2 | 27.1 | 121 | 4.76 | 64.55 | 2.54 | Displacements on request: please contact our Sales Department | |
| 29 | 28.9 | 1.764 | | | | | | |
| 33 | 33 | 2.014 | | | | | | |

| Clockwise rotation: D | | Counter-clockwise rotation: S | | Reversible motor External Drain | |
|----------------------------|------------------------------|-------------------------------|------------------------------|---------------------------------|--------------------------------|
| Standard | Low Noise | Standard | Low Noise | Standard | Low Noise |
| APM212HP/15 D 887S-NPTF | APM212HP/15LN D 887S-NPTF | APM212HP/15 S 887S-NPTF | APM212HP/15LN S 887S-NPTF | APMR212HP/15 ED 887S-NPTF | APMR212HP/15LN ED 887S-NPTF |
| APM212HP/19 D 887S-NPTF | APM212HP/19LN D 887S-NPTF | APM212HP/19 S 887S-NPTF | APM212HP/19LN S 887S-NPTF | APMR212HP/19 ED 887S-NPTF | APMR212HP/19LN ED 887S-NPTF |
| APM212HP/22 D 887S-NPTF | APM212HP/22LN D 887S-NPTF | APM212HP/22 S 887S-NPTF | APM212HP/22LN S 887S-NPTF | APMR212HP/22 ED 887S-NPTF | APMR212HP/22LN ED 887S-NPTF |
| APM212HP/26 D 887S-NPTF | APM212HP/26LN D 887S-NPTF | APM212HP/26 S 887S-NPTF | APM212HP/26LN S 887S-NPTF | APMR212HP/26 ED 887S-NPTF | APMR212HP/26LN ED 887S-NPTF |

For reversible motors alternative inlet and outlet ports have the same sizes as per inlet unidirectional rotation.

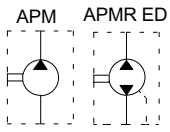

Serie
880-NPTF

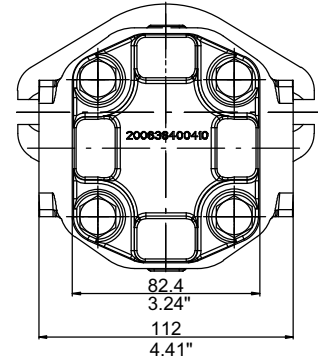
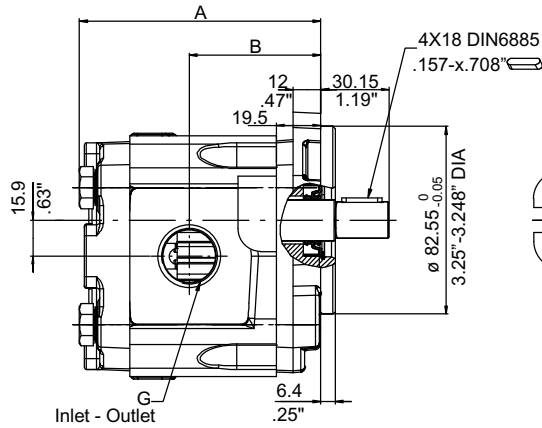
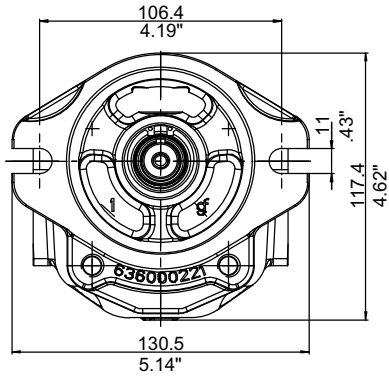
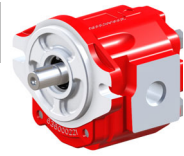

Reversible motor
ED - External Drain

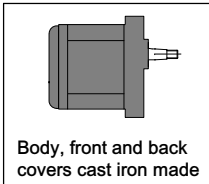
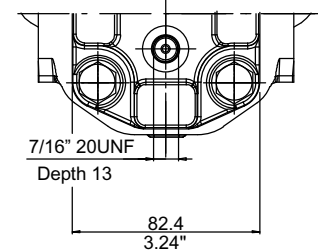

Shaft max torque: see section 3.3

Tightening torque: see section 3.5 - 3.6

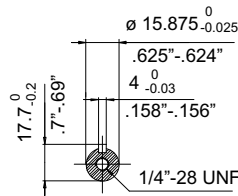

| Type | Displacement cm ³ /rev | | Dimensions | | | | Outlet G UNF-2B | Inlet G UNF-2B |
|------|--------------------------------------|------------|---|------|-------|------|-----------------------|----------------------|
| | APM212HP | APM212HPLN | A | | B | | | |
| | | | mm | inch | mm | inch | | |
| 15 | 15.1 | 15.7 | 104.5 | 4.11 | 56.3 | 2.21 | 1-1/16" 12 (SAE12) | 7/8" 14 (SAE10) |
| 19 | 19.2 | 19.8 | 110.5 | 4.35 | 59.3 | 2.33 | | |
| 22 | 22.2 | 23 | 115 | 4.52 | 61.55 | 2.42 | | |
| 26 | 26.2 | 27.1 | 121 | 4.76 | 64.55 | 2.54 | | |
| 29 | 28.9 | 1.764 | Displacements on request: please contact our Sales Department | | | | | |
| 33 | 33 | 2.014 | | | | | | |

| Clockwise rotation: D | | Counter-clockwise rotation: S | | Reversible motor External Drain | |
|---------------------------|-----------------------------|-------------------------------|-----------------------------|---------------------------------|-------------------------------|
| Standard | Low Noise | Standard | Low Noise | Standard | Low Noise |
| APM212HP/15 D 880-NPTF | APM212HP/15LN D 880-NPTF | APM212HP/15 S 880-NPTF | APM212HP/15LN S 880-NPTF | APMR212HP/15 ED 880-NPTF | APMR212HP/15LN ED 880-NPTF |
| APM212HP/19 D 880-NPTF | APM212HP/19LN D 880-NPTF | APM212HP/19 S 880-NPTF | APM212HP/19LN S 880-NPTF | APMR212HP/19 ED 880-NPTF | APMR212HP/19LN ED 880-NPTF |
| APM212HP/22 D 880-NPTF | APM212HP/22LN D 880-NPTF | APM212HP/22 S 880-NPTF | APM212HP/22LN S 880-NPTF | APMR212HP/22 ED 880-NPTF | APMR212HP/22LN ED 880-NPTF |
| APM212HP/26 D 880-NPTF | APM212HP/26LN D 880-NPTF | APM212HP/26 S 880-NPTF | APM212HP/26LN S 880-NPTF | APMR212HP/26 ED 880-NPTF | APMR212HP/26LN ED 880-NPTF |

For reversible motors alternative inlet and outlet ports have the same sizes as per inlet unidirectional rotation.

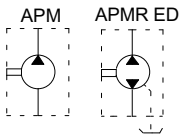

Serie
287S-B

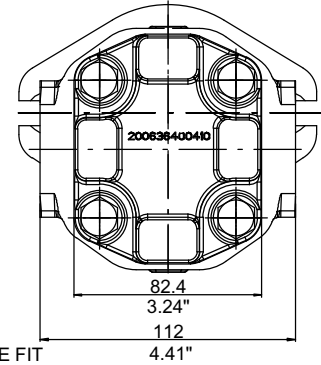
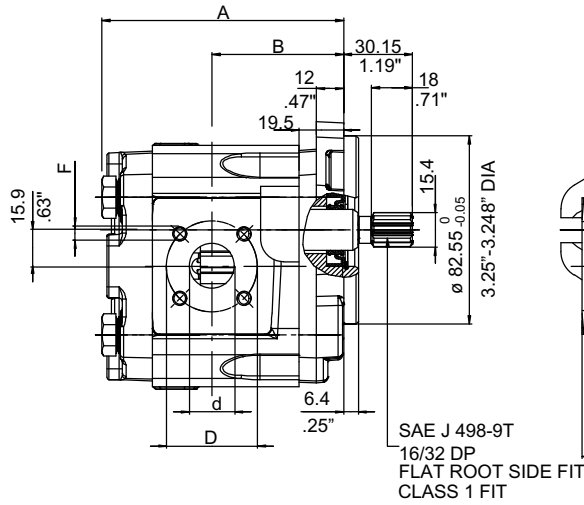
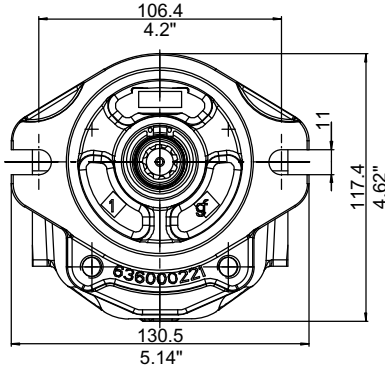

Reversible motor
ED - External Drain

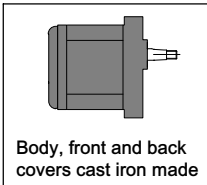
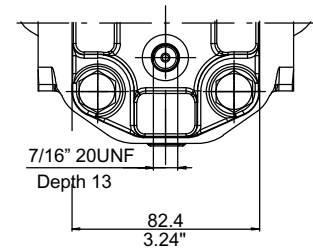

Shaft max torque: see section 3.3
Tightening torque: see section 3.5 - 3.6

| Type | Displacement cm ³ /rev | | Dimensions | | | | Outlet | | | Inlet | | | | | | |
|------|--------------------------------------|------------|---|------|---------|------|---------|------|---------|-------|----------|---------|------|---------|------|----------|
| | APM212HP | APM212HPLN | A mm | inch | B mm | inch | d mm | inch | D mm | inch | F mm | d mm | inch | D mm | inch | F mm |
| 15 | 15.1 | 15.7 | 104.5 | 4.11 | 55.3 | 2.18 | 20 | .79 | 40 | 1.58 | M6 x1 | 15 | .59 | 35 | 1.38 | M6 x1 |
| 19 | 19.2 | 19.8 | 110.5 | 4.35 | 59.3 | 2.33 | | | | | | | | | | |
| 22 | 22.2 | 23 | 115 | 4.52 | 61.55 | 2.42 | | | | | | | | | | |
| 26 | 26.2 | 27.1 | 121 | 4.76 | 64.55 | 2.54 | | | | | | | | | | |
| 29 | 28.9 | 1.764 | Displacements on request: please contact our Sales Department | | | | | | | | | | | | | |
| 33 | 33 | 2.014 | | | | | | | | | | | | | | |

| Clockwise rotation: D | | Counter-clockwise rotation: S | | Reversible motor External Drain | |
|-----------------------|-----------------------|-------------------------------|-----------------------|---------------------------------|-------------------------|
| Standard | Low Noise | Standard | Low Noise | Standard | Low Noise |
| APM212HP/15 D287S-B | APM212HP/15LN D287S-B | APM212HP/15 S287S-B | APM212HP/15LN S287S-B | APMR212HP/15 ED287S-B | APMR212HP/15LN ED287S-B |
| APM212HP/19 D287S-B | APM212HP/19LN D287S-B | APM212HP/19 S287S-B | APM212HP/19LN S287S-B | APMR212HP/19 ED287S-B | APMR212HP/19LN ED287S-B |
| APM212HP/22 D287S-B | APM212HP/22LN D287S-B | APM212HP/22 S287S-B | APM212HP/22LN S287S-B | APMR212HP/22 ED287S-B | APMR212HP/22LN ED287S-B |
| APM212HP/26 D287S-B | APM212HP/26LN D287S-B | APM212HP/26 S287S-B | APM212HP/26LN S287S-B | APMR212HP/26 ED287S-B | APMR212HP/26LN ED287S-B |

For reversible motors alternative inlet and outlet ports have the same sizes as per inlet unidirectional rotation.

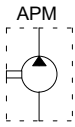

Serie
287S-SAEB

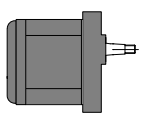
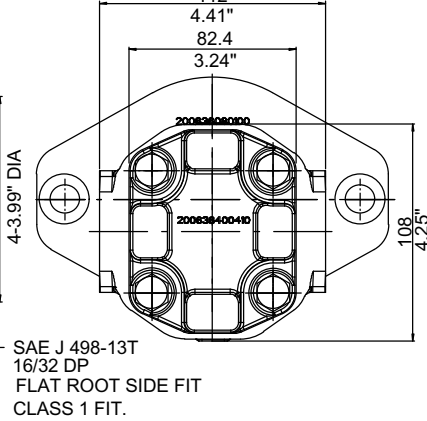
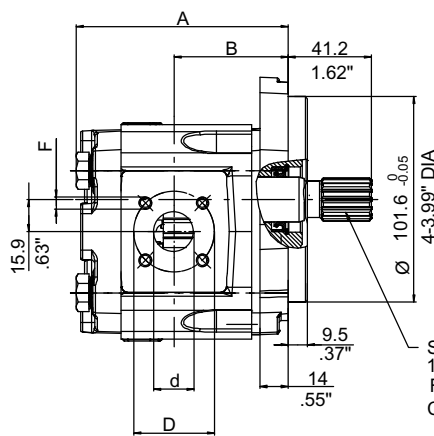
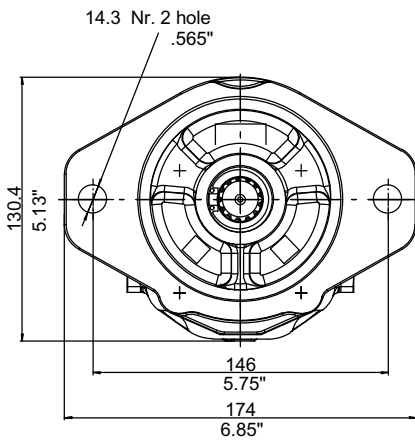

Body, front and back covers cast iron made



Attention! It is not possible to change the rotation direction. Please order always with the right code

Shaft max torque: see section 3.3

Tightening torque: see section 3.5 - 3.6

| Type | Displacement cm ³ /rev | | Dimensions | | | | Outlet | | | | | Inlet | | | | |
|------|--------------------------------------|------------|------------|------|-------|------|--------|------|----|------|-------------|-------|-----|------|------|----------|
| | APM212HP | APM212HPLN | A | B | d | D | F | d | D | F | d | D | F | | | |
| | | | mm | inch | mm | inch | mm | inch | mm | inch | mm | inch | mm | inch | mm | |
| 15 | 15.1 | 15.7 | 104.8 | 4.13 | 56.5 | 2.22 | 20 | .79 | 40 | 1.58 | M6 x1 | 15 | .59 | 35 | 1.38 | M6 x1 |
| 19 | 19.2 | 19.8 | 110.8 | 4.36 | 59.5 | 2.34 | | | | | | | | | | |
| 22 | 22.2 | 23 | 115.3 | 4.54 | 61.75 | 2.43 | | | | | | | | | | |
| 26 | 26.2 | 27.1 | 121.3 | 4.78 | 64.75 | 2.55 | | | | | | | | | | |
| 29 | 28.9 | 29.9 | 125.3 | 4.93 | 66.75 | 2.63 | 24 | .94 | 55 | 2.16 | M8x 1.25 | | | | | |
| 33 | 33 | 34.1 | 131.3 | 5.17 | 69.75 | 2.75 | | | | | | | | | | |

| Clockwise rotation: D | | | | Counter-clockwise rotation: S | | | |
|-------------------------|---------------------------|-------------------------|---------------------------|-------------------------------|---------------------------|-------------------------|---------------------------|
| Standard | | Low Noise | | Standard | | Low Noise | |
| APM212HP/15 D 287S-SAEB | APM212HP/15LN D 287S-SAEB | APM212HP/15 S 287S-SAEB | APM212HP/15LN S 287S-SAEB | APM212HP/19 D 287S-SAEB | APM212HP/19LN D 287S-SAEB | APM212HP/19 S 287S-SAEB | APM212HP/19LN S 287S-SAEB |
| APM212HP/22 D 287S-SAEB | APM212HP/22LN D 287S-SAEB | APM212HP/22 S 287S-SAEB | APM212HP/22LN S 287S-SAEB | APM212HP/26 D 287S-SAEB | APM212HP/26LN D 287S-SAEB | APM212HP/26 S 287S-SAEB | APM212HP/26LN S 287S-SAEB |

For reversible motors alternative inlet and outlet ports have the same sizes as per inlet unidirectional rotation.

3 APM212HP Single motor customised versions

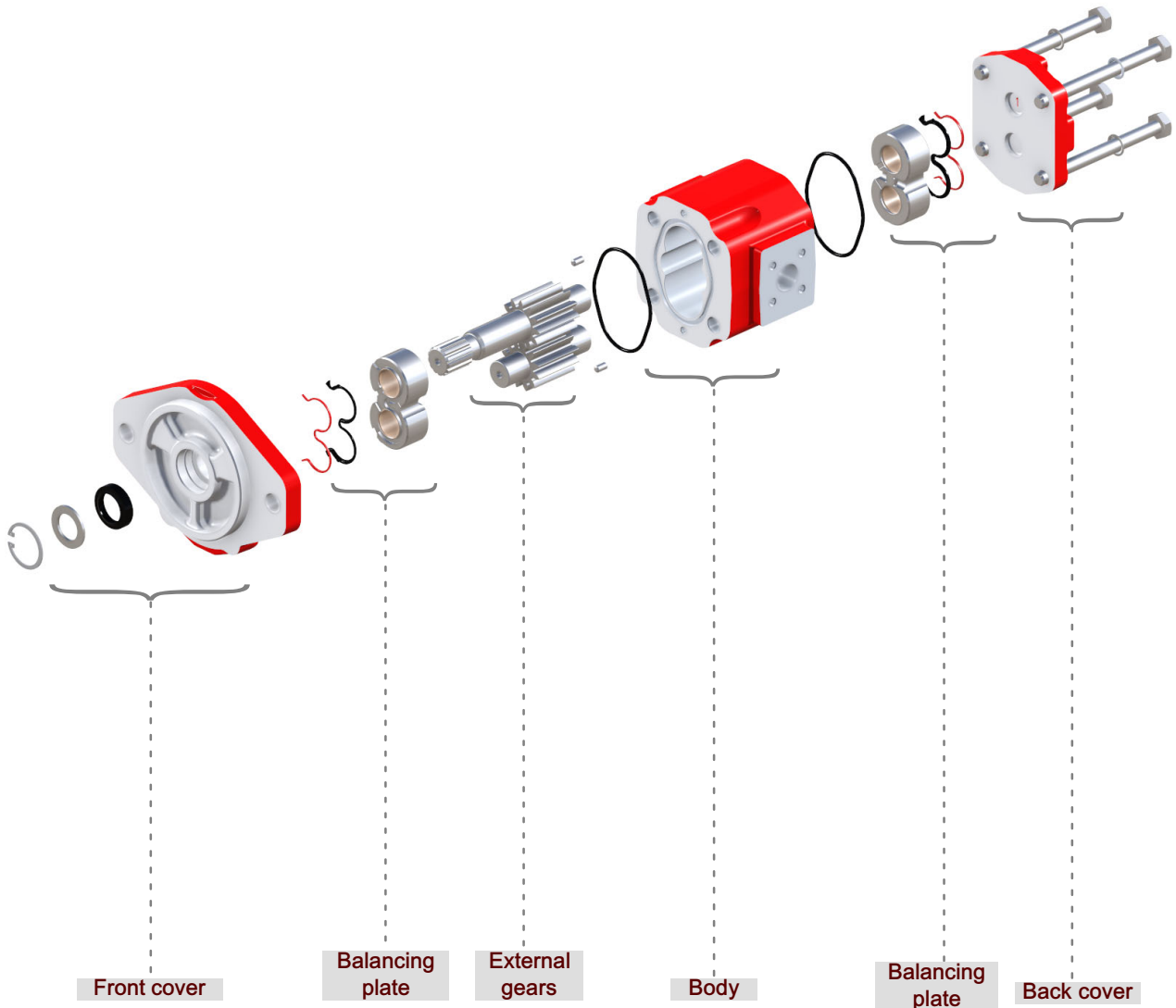

In this section, a single APM212HP motor can be configured and customized.

APM212HP wide availability of covers, bodies, gears and seals sets provides great flexibility to APM212HP motor range and allows several different motor configurations.

In order to simplify the selection of the desired motor combination, a 'configurator form' is available and, by filling it out, it will guide you in the motor creation process.

3.1 Single motor customised versions order example

| | | | | | | | | | | | | | | | | | | | | | | | | | | | | |
|---|---|------------------------|---|---|---|--|---|---|---|--|---|---|---|---|---|--|---|---|---|---|---|---|---|---|---|---|---|---|
| A | P | M | 2 | 1 | 2 | H | P | / | 1 | 5 | L | N | - | S | - | A | 0 | S | - | 8 | A | - | G | H | 1 | - | * | * |
| Function APM= single gear motor - unidirectional APMR = single gear motor - reversible | | Series 212HP | | Displacement 15= 15.1 cm ³ /rev 19= 19.2 cm ³ /rev 22= 22.2 cm ³ /rev 26= 26.2 cm ³ /rev 29= 28.9 cm ³ /rev 33= 33 cm ³ /rev | | Version Omitted if 12 teeth standard LN= 12 teeth Low Noise version | | Rotation S = left-hand rotation D = Right-hand rotation Omitted if reversible version | | Shaft end code see section 3.3 | | Shaft seal material type code see section 3.4.1 | | Front cover series/material with/without bearing code see section 3.4.2 and 3.4.3 | | Type of ports code see section 3.5 | | Inlet/outlet port size code combination see section 3.5 | | Back cover type see section 3.6 | | BHRE section : Version - Progressive number (omitted) | | | | | | |
| | | | | | | | | | | | | | | | | | | | | | | | | | | | | |

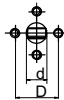



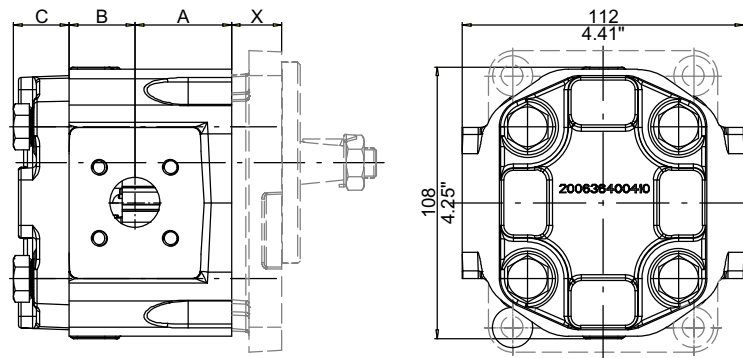

3.2 Single motor dimensions



| motor size | A | | B | | C* | |
|-------------|-------|--------|-------|--------|--|--|
| | mm | inches | mm | inches | mm | inches |
| APM212HP/15 | 38.3 | 1.51 | 26.3 | 1.04 | 22 (28 with tie rod + nut for tandem) | 0.87" (1.10" with tie rod + nut for tandem) |
| APM212HP/19 | 41.3 | 1.63 | 29.3 | 1.15 | | |
| APM212HP/22 | 43.55 | 1.71 | 31.55 | 1.24 | | |
| APM212HP/26 | 46.55 | 1.83 | 34.55 | 1.36 | | |
| APM212HP/29 | 48.55 | 1.91 | 36.55 | 1.44 | | |
| APM212HP/33 | 51.55 | 2.03 | 39.55 | 1.56 | | |

C*: dimensions with standard cast iron back cover and screws.
For other back covers dimension see section 3.6

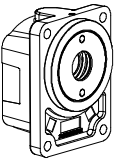
3.2.1 Cast iron front cover dimensions

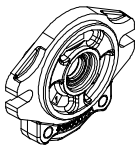
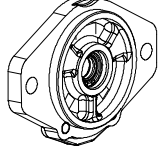
| Front cover type | x | | Front cover type | x | |
|--|------|--------|---|------|--------|
| | mm | inches | | mm | inches |
| German rectangular  | 20 | 0.79 | European rectangular  | 19 | 0.75 |
| Bearing support German version  | 48.5 | 1.91 | Through 2 bolts  | 17.2 | 0.68 |
| SAE-A 2 bolts  | 19.5 | 0.77 | SAE-B 2 bolts  | 18.2 | 0.72 |

3.3 Shaft end code

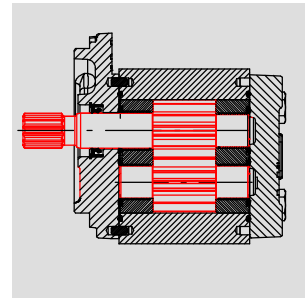
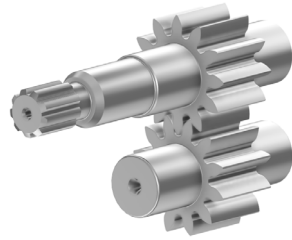

A P M 2 1 2 H P / 1 5 - S - A 0 S - 8 A - V E 1 6 - A

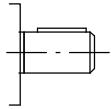
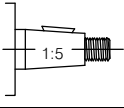
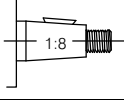
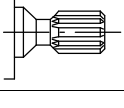
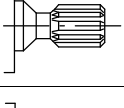
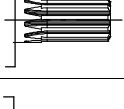
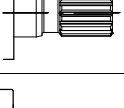
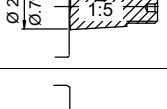
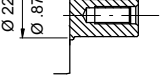
| Shaft end shape | Shaft end ordering code | Max torque | |
|---|--|-------------------|----------------|
|  | Straight keyed Ø 15,85 mm - 0.62 inches | S | T max = 65 Nm |
|  | Tapered shaft 1:5 | G | T max = 135 Nm |
|  | Tapered shaft 1:8 | E | T max = 135 Nm |
|  | 9 Teeth external spline B17X14 DIN5482 | D | T max = 110 Nm |
|  | 9 teeth external spline SAE J 498-9T 16/32 DP | A | T max = 90 Nm |
|  | 11 teeth external spline SAE J 498-11T 16/32 DP | T | T max = 140 Nm |
|  | 13 teeth external spline SAE J 498-13T 16/32 DP | B | T max = 270 Nm |
|  | Bearing application 1:5 | See section 3.4.3 | T max = 100 Nm |
|  | Bearing application Straight 22 mm - 0.87 inches | See section 3.4.3 | T max = 100 Nm |

3.4 Front cover

3.4.1 Shaft seal material

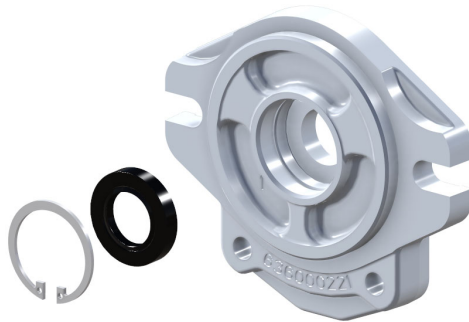

A P M 2 1 2 H P / 1 5 - S - A 0 S - 8 A - V E 1 6 - A



| Shaft seal Type/material | Ordering code |
|---|---------------|
| Shaft seal motor NBR | 5 |
| Shaft seal motor HNBR (standard) | 6 |
| FPM (VITON) | 7 |
| High back pressure shaft seal (reduced life see note 1.9) | 8 |

3.4.2 Cast iron front cover type

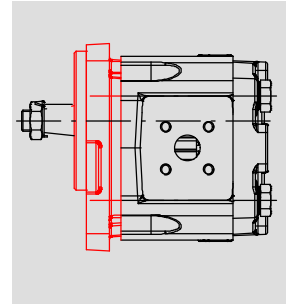

A P M 2 1 2 H P / 1 5 - S - A 0 S - 8 A - V E 1 6 - A

| Type | Cast iron | | Cast iron + bearing | | Cooling system | |
|--|-----------|---------------|---------------------|-------------------|-----------------------------|---------------|
| | Shape | Ordering code | Shape | Ordering code | Cast iron + dust protection | Ordering code |
| German rectangular (Ø 80 mm - 3.15 inches) | | B | | see section 3.4.3 | | F |
| European rectangular (Ø 36.5 mm - 1.44") | | E | | * | | K |
| Through 2 bolts (Ø 50 mm - 1.97") | | H | | * | | I |
| Through 2 bolts (Ø 50 mm - 1.97") | | M | | * | | N |
| SAE-A 2 bolts (Ø 82.55 mm - 3.25 inches) | | S | | * | | Q |
| SAE-B 2 bolts (Ø 101,6 mm - 4 inches) | | V | | | | * |

Cast iron front cover dimensions: see standard motors data sheet

* Please contact our Sales Department

3.4.3 Front bearing application

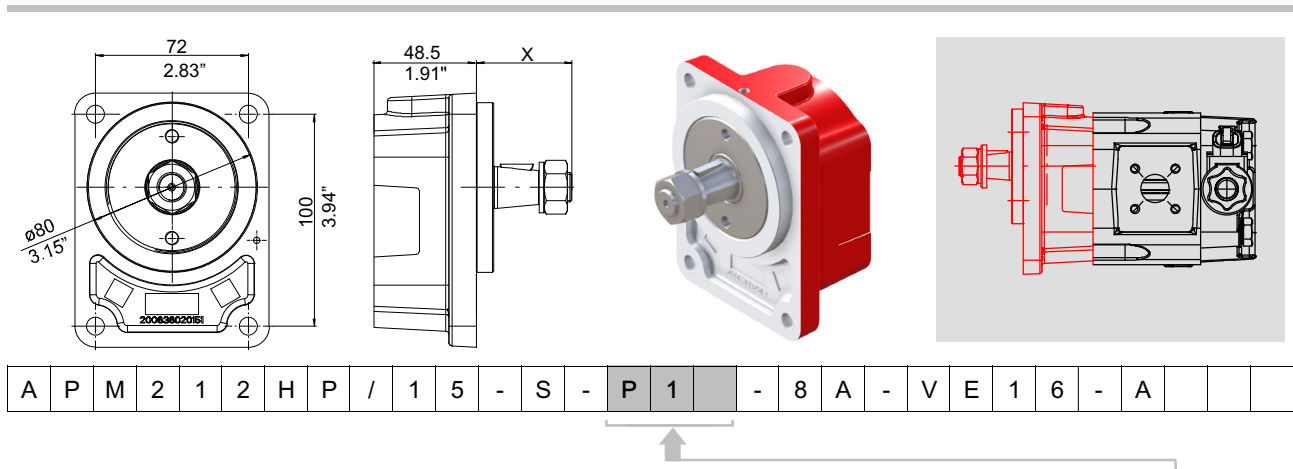

A P M 2 1 2 H P / 1 5 - S - P 1 - 8 A - V E 1 6 - A

| | | | | | | |
|--|---|---|---|--|---|-----------------------------|
| | + | | + | Shaft seal material: HNBR (Standard) | = | P1 T max = 100 Nm |
| | + | X = 45 mm (1.77 inches) | + | High pressure seal (Reduced life component: see note on section 1.9) | = | P2 T max = 80 Nm |
| | + | | + | Shaft seal material: HNBR (Standard) | = | C1 T max = 100 Nm |
| | + | Straight 22 mm - 0.87 inches X = 48.5 mm (1.91 inches) | + | High pressure seal (Reduced life component: see note on section 1.9) | = | C2 T max = 80 Nm |

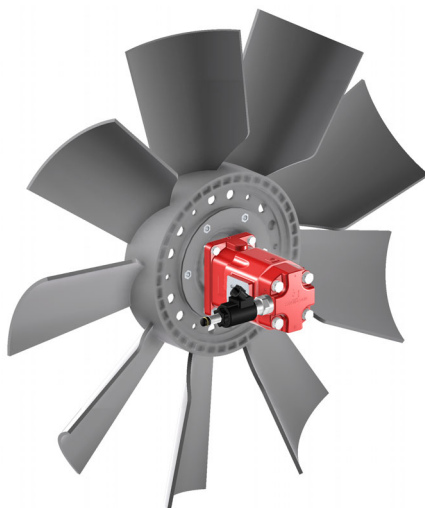

Maximum Axial force admitted with radial load lesser than 100 N

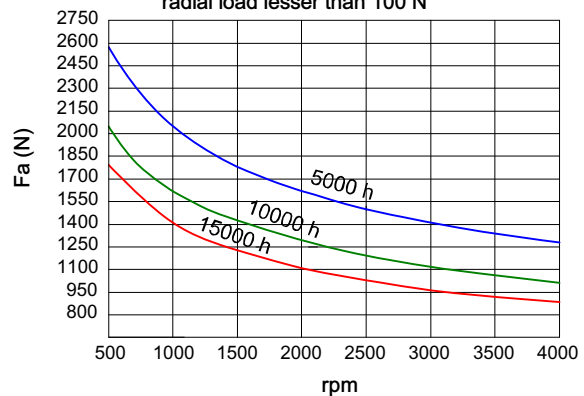

See section 1.8.2

3.5 Cast iron body

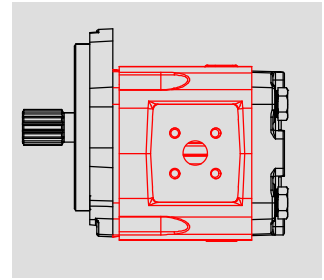
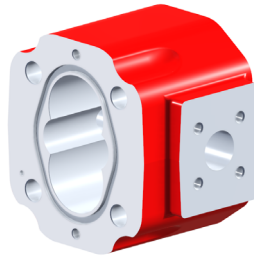

For reversible motors inlet and outlet ports have the same sizes as per inlet unidirectional rotation.

| | | | | | | | | | | | | | | | | | | | | | | | | | | | | |
|---|---|---|---|---|---|---|---|---|---|---|---|---|---|---|---|---|---|---|---|---|---|---|---|---|---|---|--|--|
| A | P | M | 2 | 1 | 2 | H | P | / | 1 | 5 | - | S | - | A | 0 | S | - | 8 | A | - | V | E | 1 | 6 | - | A | | |
|---|---|---|---|---|---|---|---|---|---|---|---|---|---|---|---|---|---|---|---|---|---|---|---|---|---|---|--|--|

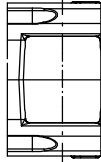
| Port type | Ordering code | Displacement | Dimension (mm - inch) | | Ordering code |
|--|---------------|--------------|-----------------------|-------|---------------|
| | | | Outlet | Inlet | |
|  | without | 0 | All | | 0 |
| | | | 19-22-26 29-33 | | D |

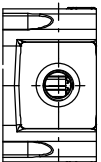
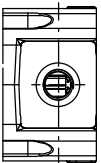
| Port type | Ordering code | Displacement | Dimension (mm - inch) | | Ordering code | |
|---|---------------------|--------------|-----------------------|-----------|---------------|---|
| | | | Outlet | Inlet | | |
|  | metric | 1 | 15 | On demand | B | |
| | | | 19-22-26 | | C | |
| | | | 29-33 | | D | |
|  | BSPP threaded ports | 4 | 15 | 1/2" | 3/8" | B |
| | | | 19-22-26 | 3/4" | 1/2" | C |
| | | | 29-33 | 1" | 1/2" | D |

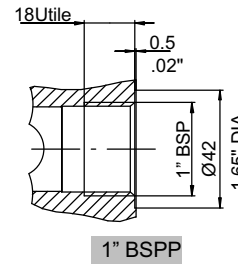
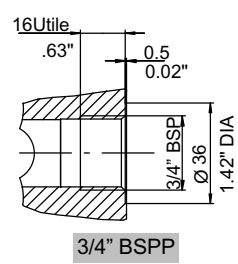
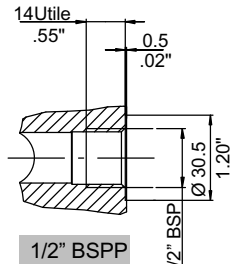
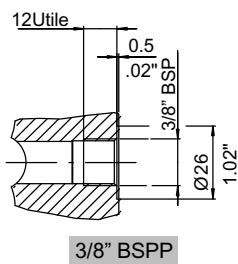

| Recommended tightening torque for work port fittings - Nm / lbf | | | | |
|---|------------------|------------------|------------------|-------------------|
| BSP - ISO 228-1 | 3/8" BSP | 1/2" BSP | 3/4" BSP | 1" BSP |
| With copper washer (ISO 1179-1) | 40 / 29.5 (±10%) | 60 / 44.3 (±10%) | 90 / 66.4 (±10%) | 100 / 73.8 (±10%) |
| With rubber washer or steel (ISO 1179-1) | 35 / 25.8 (±10%) | 60 / 44.3 (±10%) | 70 / 51.7 (±10%) | 90 / 66.4 (±10%) |

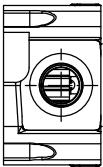
| Port type | Ordering code | Displacement | Dimension (mm - inch) | | Ordering code | |
|---|--------------------|--------------|-----------------------|---------------------------|------------------------|---|
| | | | Outlet | Inlet | | |
|  | SAE threaded ports | 8 | all | 1-1/16" 12 UNF-2B (SAE12) | 7/8" 14 UNF-2B (SAE10) | A |

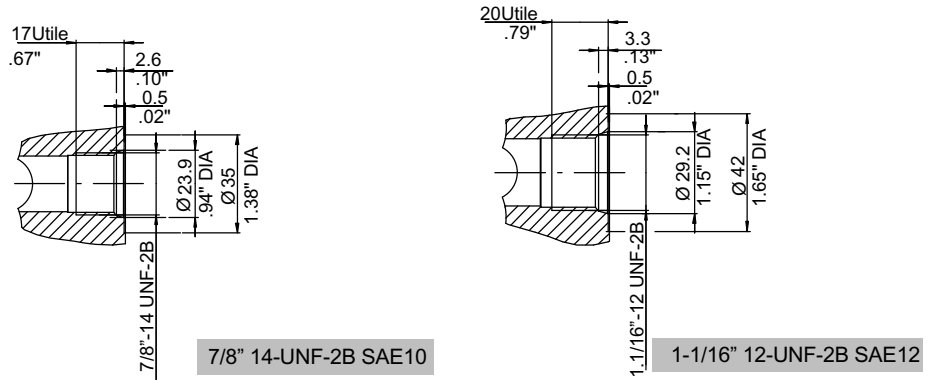

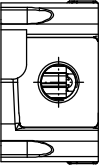
| | | | | | | |
|--|---------------------|---|-------------|------|------|---|
|  | NPTF threaded ports | 6 | 15-19-22-26 | 3/4" | 1/2" | B |
| | | | 29-33 | 1" | 1/2" | E |

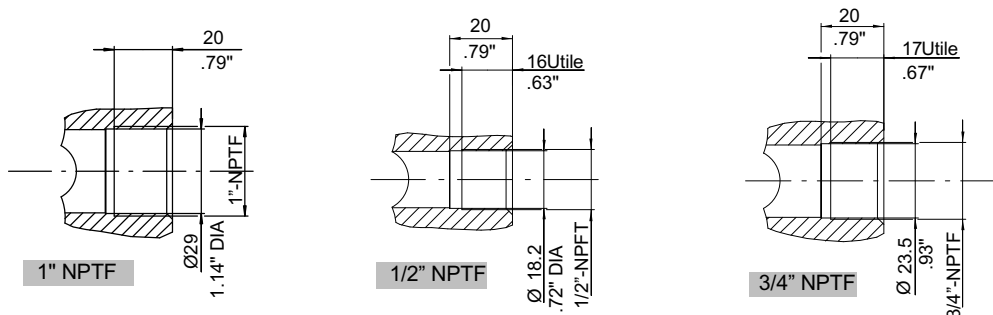

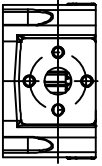
| | | | | | | |
|---|-----------------|---|----------------|---|---|---|
|  | European 4 bolt | 3 | 15 | 19 - .75 (d) 40 - 1.58 (D) M8 (F) | 13.5 - .53 (d) 30 - 1.18 (D) M6 (F) | B |
| | | | 19-22-26-29-33 | 19 - .75 (d) 40 - 1.58 (D) M8 (F) | 19 - .75 (d) 40 - 1.58 (D) M8 (F) | C |

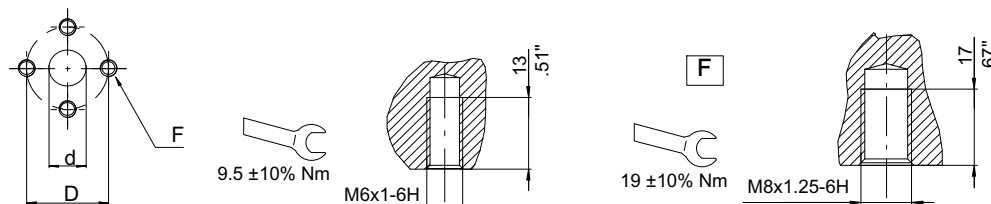

Recommended tightening torque for work port fittings - Nm / lbf

| UN-UNF - ISO 263 | SAE10 - 7/8-14UNF | SAE12 - 1-1/16-12UNF |
|--------------------------------|-------------------|----------------------|
| With O-Ring seal (ISO 11926-1) | 60 / 44.3 (±10%) | 90 / 66.4 (±10%) |

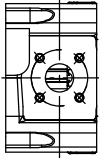
| Type | Ordering code | Displacement | Dimension (mm - inch) | | Ordering code |
|--|---------------|-----------------------|---|--|---------------|
| | | | Outlet | Inlet | |
|  German 4 bolt flanged | 2 | 15-19-22-26 | 20 - .79 (d) 40 - 1.58 (D) M6 (F) | 15 - .59 (d) 35 - 1.38 (D) M6 (F) <u>287-S SAEB: M6 (F)</u> | B |
| | | 29-33 (287-S SAEB) | 24 - .95 (d) 55 - 2.17 (D) M8 (F) (287-S SAEB) | | |

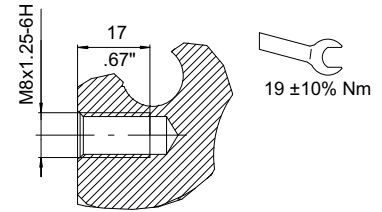
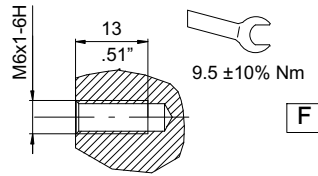
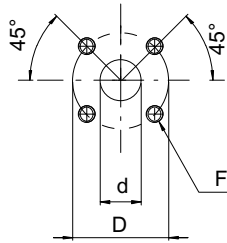

| | | |
|-------------|---|---|
| Other ports | 9 | If the requested port type is not included in the previous versions, please indicate number "9" and specify the details in the request note |
|-------------|---|---|

3.5.1 Body seals material: HNBR (standard)

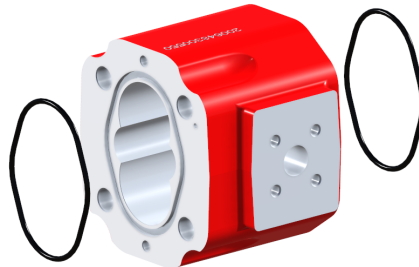

3.6 Back covers

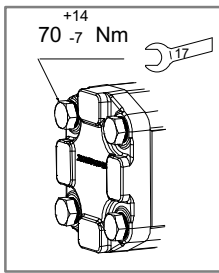

Dedicated 212HP torque value, higher than 212 standard aluminium version

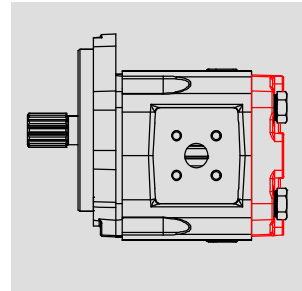
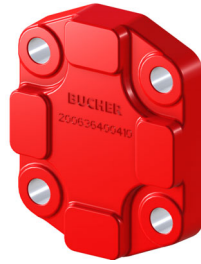

3.6.1 Cast iron back cover - Standard version for unidirectional motor

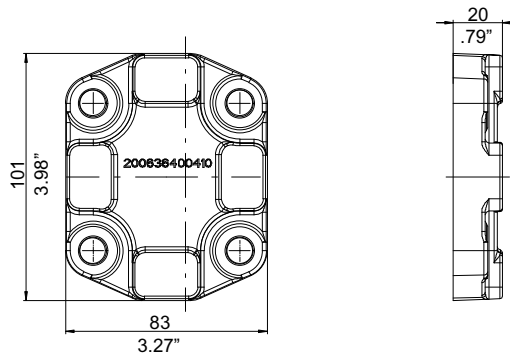

| | | | | | | | | | | | | | | | | | | | | | | | | | | | | | |
|---|---|---|---|---|---|---|---|---|---|---|---|---|---|---|---|---|---|---|---|---|---|---|---|---|---|--|--|--|--|
| A | P | 2 | 1 | 2 | H | P | / | 1 | 5 | - | S | - | A | 0 | S | - | 8 | A | - | G | H | - | - | - | A | | | | |
|---|---|---|---|---|---|---|---|---|---|---|---|---|---|---|---|---|---|---|---|---|---|---|---|---|---|--|--|--|--|

| Type | Ordering code |
|--|---------------|
| Back cover, standard version, cast iron material | GH |

3.6.2 Cast iron back cover with drain port - Standard version for bidirectional motor

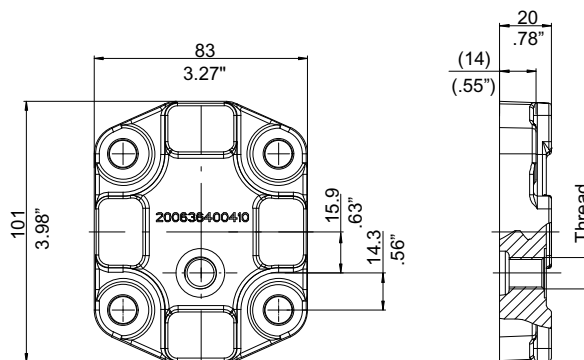
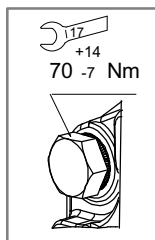

| | | | | | | | | | | | | | | | | | | | | | | | | | | | | |
|---|---|---|---|---|---|---|---|---|---|---|---|---|---|---|---|---|---|---|---|---|---|---|---|---|--|--|--|--|
| A | P | R | 2 | 1 | 2 | H | P | / | 1 | 5 | - | A | 0 | S | - | 8 | A | - | G | 1 | - | - | - | A | | | | |
|---|---|---|---|---|---|---|---|---|---|---|---|---|---|---|---|---|---|---|---|---|---|---|---|---|--|--|--|--|

| Type | Thread | Tightening torque | Ordering code |
|--|----------|-----------------------------------|---------------|
| Back cover with external drain line, cast iron material for reversible motor | 1/4" BSP | 30 ⁻⁶ ₊₇ Nm | G1 (Standard) |
| | SAE4 | 20 ⁻⁵ ₊₅ Nm | G2 |
| | M12x1.5 | 30 ⁻⁶ ₊₇ Nm | G3 |

3.7 Valves and circuits

3.7.1 Anticavitation valves DN 3,5 mm integrated inside unidirectional motor

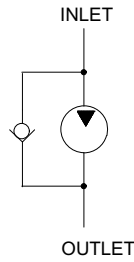

| | | | | | | | | | | | | | | | | | | | | | | | | | | | |
|---|---|---|---|---|---|---|---|---|---|---|---|---|---|---|---|---|---|---|---|---|---|---|---|---|---|--|--|
| A | P | M | 2 | 1 | 2 | H | P | / | 8 | , | 5 | - | D | - | A | 6 | S | - | 1 | C | - | G | H | + | C | | |
|---|---|---|---|---|---|---|---|---|---|---|---|---|---|---|---|---|---|---|---|---|---|---|---|---|---|--|--|

3.7.2 Anticavitation valves DN 3,5 mm integrated inside bidirectional motor used in only one direction

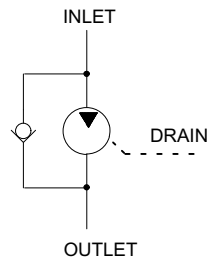

| | | | | | | | | | | | | | | | | | | | | | | | | | | | | |
|---|---|---|---|---|---|---|---|---|---|---|---|---|---|---|---|---|---|---|---|---|---|---|---|---|---|---|--|--|
| A | P | M | R | 2 | 1 | 2 | H | P | / | 8 | , | 5 | - | D | - | A | 6 | S | - | 1 | C | - | G | 1 | + | C | | |
|---|---|---|---|---|---|---|---|---|---|---|---|---|---|---|---|---|---|---|---|---|---|---|---|---|---|---|--|--|

3.7.3 Anticavitation valve assembled inside cast iron back cover

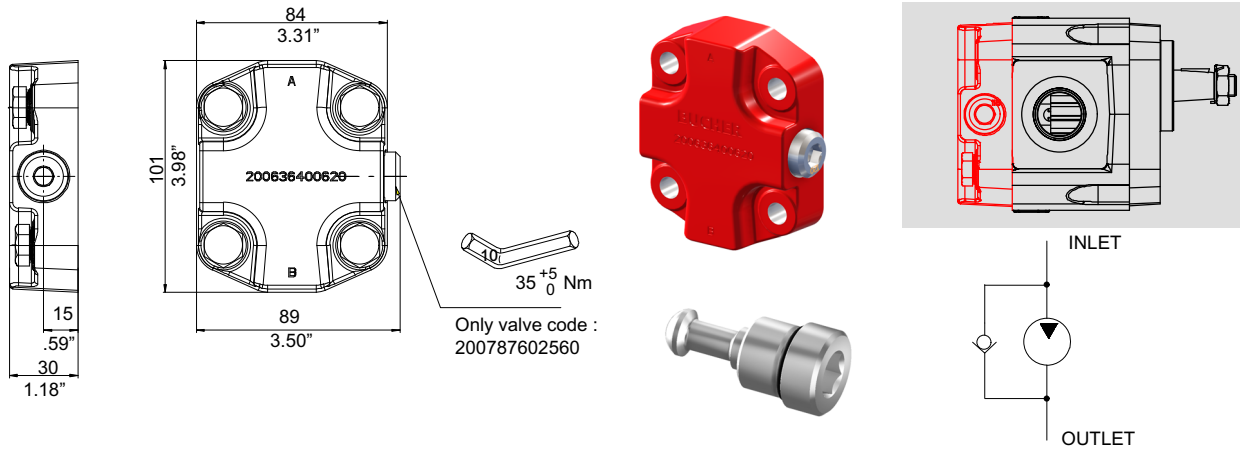

| | | | | | | | | | | | | | | | | | | | | | | | | | | | |
|---|---|---|---|---|---|---|---|---|---|---|---|---|---|---|---|---|---|---|---|---|---|---|---|---|---|--|--|
| A | P | M | 2 | 1 | 2 | H | P | / | 8 | , | 5 | - | D | - | A | 6 | S | - | 1 | C | - | + | C | A | V | | |
|---|---|---|---|---|---|---|---|---|---|---|---|---|---|---|---|---|---|---|---|---|---|---|---|---|---|--|--|

3.7.4 Double anticavitation valves assembled directly inside front cover (cast iron only)

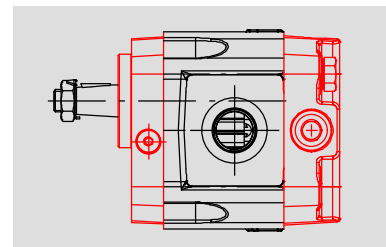
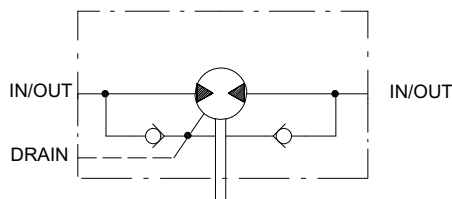

| | | | | | | | | | | | | | | | | | | | | | | | | | | | | |
|---|---|---|---|---|---|---|---|---|---|---|---|---|---|--|---|---|---|---|---|---|---|---|---|---|---|---|---|--|
| A | P | M | R | 2 | 1 | 2 | H | P | / | 8 | , | 5 | - | | - | A | 6 | S | - | 1 | C | - | G | 1 | + | C | F | |
|---|---|---|---|---|---|---|---|---|---|---|---|---|---|--|---|---|---|---|---|---|---|---|---|---|---|---|---|--|

3.7.5 Cast iron back cover with integrated valve: antishock-anticavitation valve, fixed setting

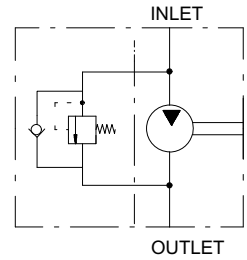
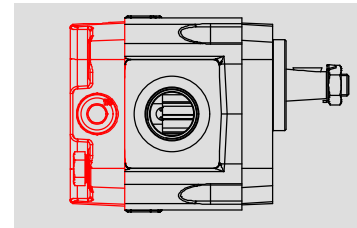
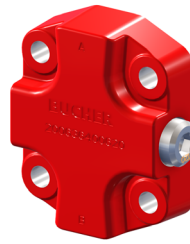
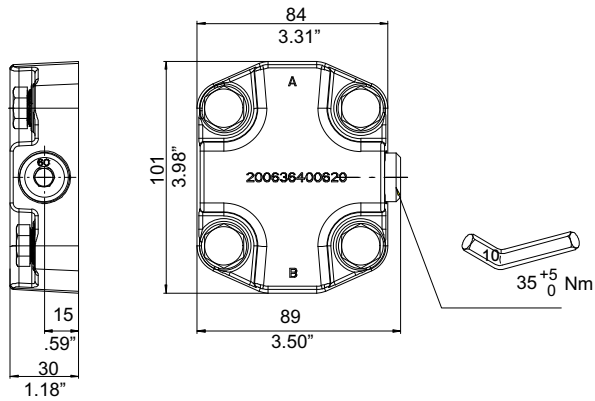

A P M 2 1 2 H P / 8 , 5 - D - A 6 S - 1 C - U C 1 6

Anti-shock and anti-cavitation valves UC

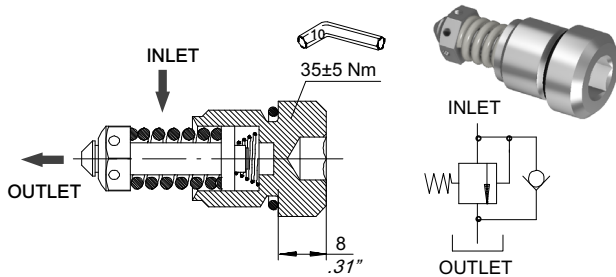

Antishock

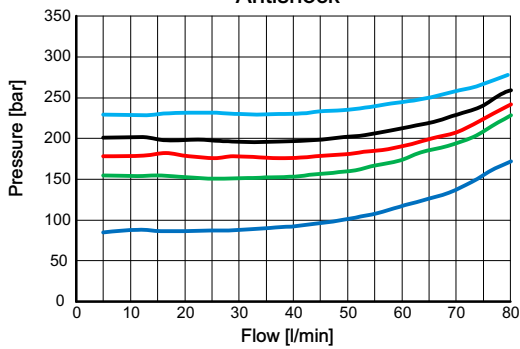

Anticavitation

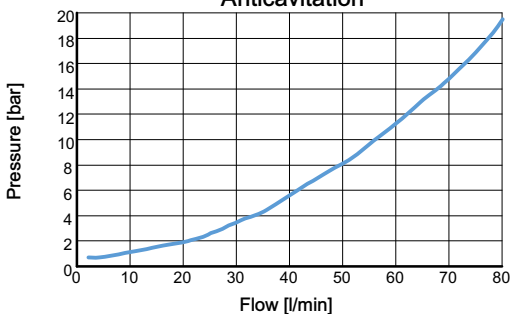

| Pressure setting at 10 l/min (*) bar (PSI) | Code |
|---|--------------|
| 40 (580) | 200533930068 |
| 60 (870) | 200533930077 |
| 70 (1010) | 200533930050 |
| 80 (1160) | 200533930050 |
| 90 (1300) | 200533930084 |
| 100 (1450) | 200533930100 |
| 110 (1590) | 200533930110 |
| 120 (1740) | 200533930085 |
| 130 (1880) | 200533930057 |
| 140 (2030) | 200533930059 |
| 150 (2170) | 200533930051 |
| 160 (2320) | 200533930067 |
| 170 (2460) | 200533930071 |
| 180 (2610) | 200533930056 |
| 190 (2750) | 200533930113 |
| 200 (2900) | 200533930060 |
| 210 (3040) | 200533930080 |
| 220 (3190) | 200533930064 |
| 230 (3330) | 200533930058 |
| 240 (3480) | 200533930081 |
| 250 (3620) | 200533930052 |
| VC (plug) | 200778400310 |

3.7.6 Back cover in cast iron with drain port and integrated valve: antishock-anticavitation valve, fixed setting

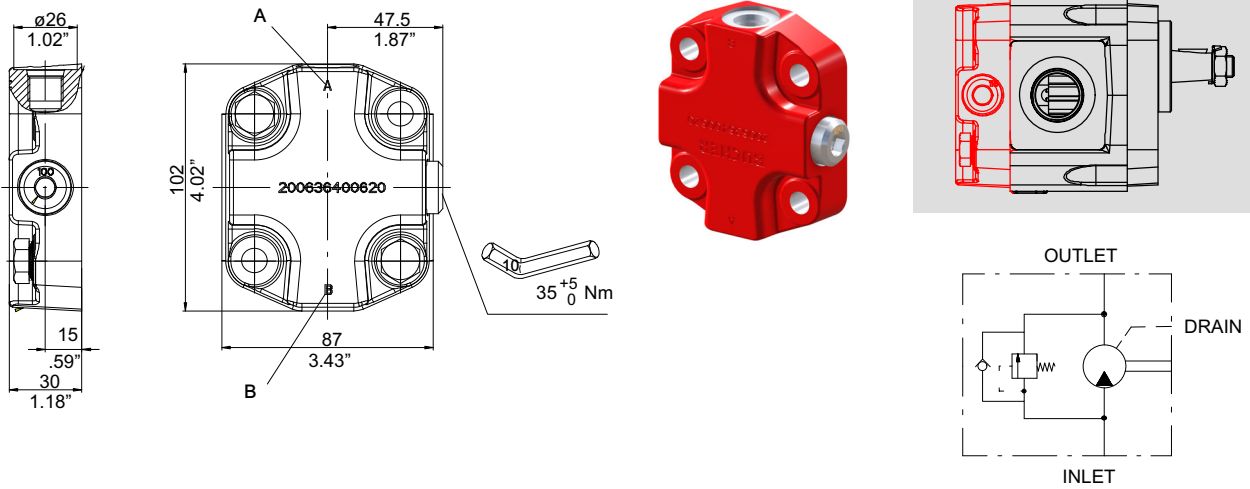

Valve characteristics see section 3.7.5

| | | | | | | | | | | | | | | | | | | | | | | | | | | | | | |
|---|---|---|---|---|---|---|---|---|---|---|---|---|---|---|---|---|---|---|---|---|---|---|---|---|---|---|---|---|---|
| A | P | M | R | 2 | 1 | 2 | H | P | / | 8 | , | 5 | - | D | - | A | 6 | S | - | 1 | C | - | U | C | 1 | 6 | - | G | 4 |
|---|---|---|---|---|---|---|---|---|---|---|---|---|---|---|---|---|---|---|---|---|---|---|---|---|---|---|---|---|---|

UC16 = Antishock-anticavitation valve ordering code
(see section 3.7.5)

G Cast iron back cover

4 = Drain line port type

Drain line port:

| Thread | Tightening torque | Ordering code |
|----------|-------------------|----------------|
| 1/4" BSP | 30_{+7}^{-6} Nm | 1 (on request) |
| M12x1.5 | 30_{+7}^{-6} Nm | 3 (on request) |
| SAE6 | 20_{+5}^0 Nm | 4 (standard) |

3.7.7 Back cover in cast iron with drain port with integrated valve: Double antishock-anticavitation valves, fixed setting

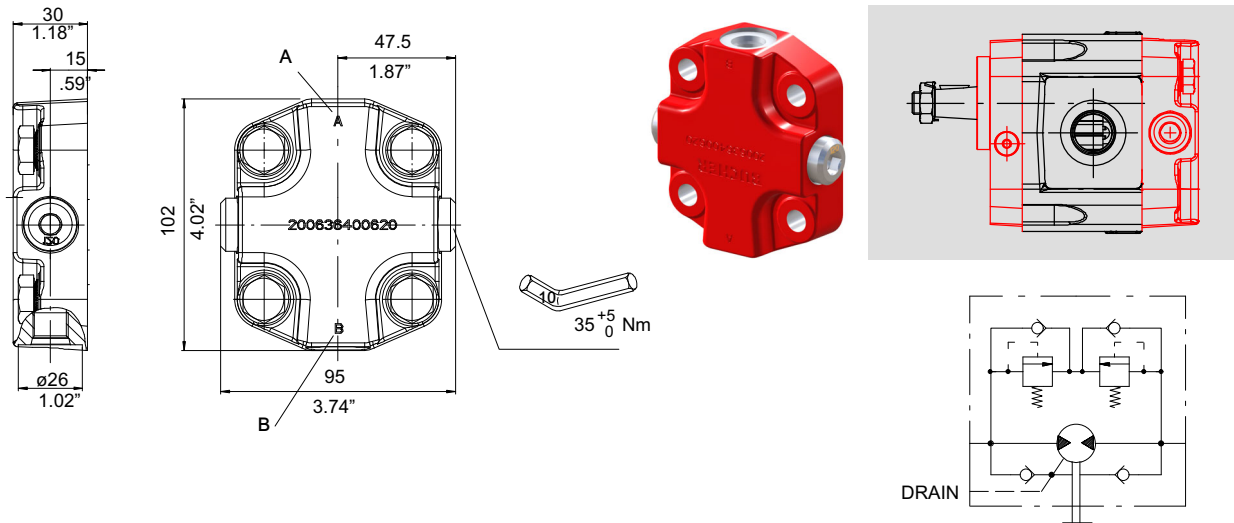

A P M R 2 1 2 H P / 8 , 5 - A 6 S - 1 C - U C 1 6 - G 4 A + C F

UC16 = Antishock-anticavitation valve ordering code
(see section 3.7.5)

G Cast iron back cover

4 = Drain line port type

Drain line port:

| Thread | Tightening torque | Ordering code |
|----------|-------------------------------------|----------------|
| 1/4" BSP | 30 ⁻⁶ / ₊₇ Nm | 1 (on request) |
| M12x1.5 | 30 ⁻⁶ / ₊₇ Nm | 3 (on request) |
| SAE6 | 20 ⁰ / ₊₅ Nm | 4 (standard) |

A = Drain line port position

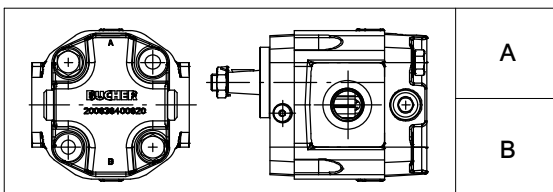

Anticavitation valve integrated inside the front cover is requested, please specify +CF

IMPORTANT! This circuit must be combined with front cover in cast iron, anticavitation valves included (see section 3.7.4)

3.7.8 Cast iron back cover with integrated valves: proportional relief valve ($Q_{max} = 60 \text{ l/min}$)

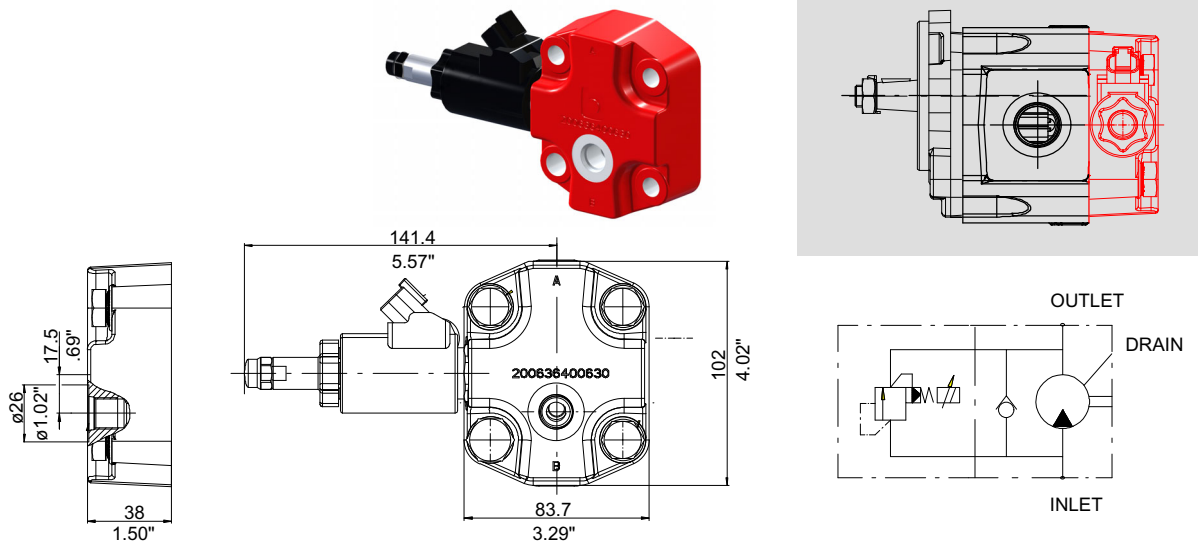

| | | | | | | | | | | | | | | | | | | | | | | | | | | | | | |
|---|---|---|---|---|---|---|---|---|---|---|---|---|---|---|---|---|---|---|---|---|---|---|---|---|---|---|---|---|---|
| A | P | M | R | 2 | 1 | 2 | H | P | / | 8 | , | 5 | - | D | - | A | 6 | S | - | 1 | C | - | L | 2 | 3 | A | 4 | + | C |
|---|---|---|---|---|---|---|---|---|---|---|---|---|---|---|---|---|---|---|---|---|---|---|---|---|---|---|---|---|---|

L = Type of cast iron back cover/valve combination

Back cover with "AL" cavity and proportional pressure-relief cartridge valve type $Q_{max} = 60 \text{ l/min}$

Inverse proportional pressure-relief cartridge, size 5, DBVSA-1LG (NBR seals)

23 = Pressure settings

Pressure range :
 10 = 100 bar
 16 = 160 bar
 23 = 230 bar

For further settings value available please consult Bucher Hydraulics



ATTENTION!

To prevent any pressure surges, outlet port must be routed to tank with the least possible back-pressure. Any tank pressure acting at outlet port is additive to the pressure setting at the main inlet port.



IMPORTANT!

Further note and characteristics available in the dedicated catalogue 400-P-586101-E

$p = f(I)$ Pressure adjustment characteristic ($Q = 5 \text{ l/min}$)

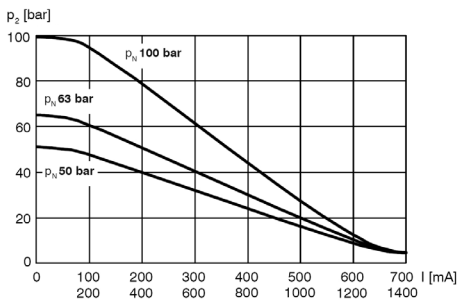

$p = f(I)$ Pressure adjustment characteristic ($Q = 5 \text{ l/min}$)

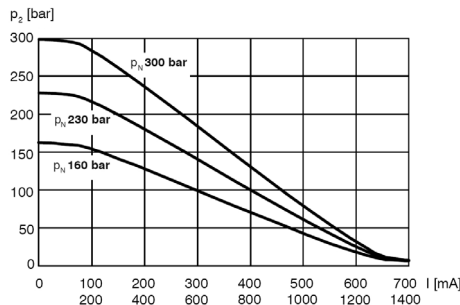

A = Solenoid connection type and nominal voltage

Connection type: DT AJ
 A = 12 V DC C = 12 V DC
 B = 24 V DC D = 24 V DC



IMPORTANT!

To achieve the proportional pressure-relief cartridge's maximum performance rating, fit the solenoid coil with the plug pins at the top. When fitting the cartridges, note the mounting attitude (preferably vertical, with coil down automatic air bleed) and use the specified tightening torque. No adjustments are necessary, since the cartridges are set in the factory.

4 = Drain line port type

Drain line port:

| Thread | Tightening torque | Ordering code |
|----------|---------------------------|----------------|
| 1/4" BSP | 30_{-6}^{+7} Nm | 1 (on request) |
| M12x1.5 | 30_{-6}^{+7} Nm | 3 (on request) |
| SAE6 | 30_{-6}^{+7} Nm | 4 (standard) |

If the anticavitation valve integrated inside the motor is requested, please specify +C

3.7.9 Cast iron back cover with integrated valves: proportional relief valve ($Q_{max} = 120 \text{ l/min}$)

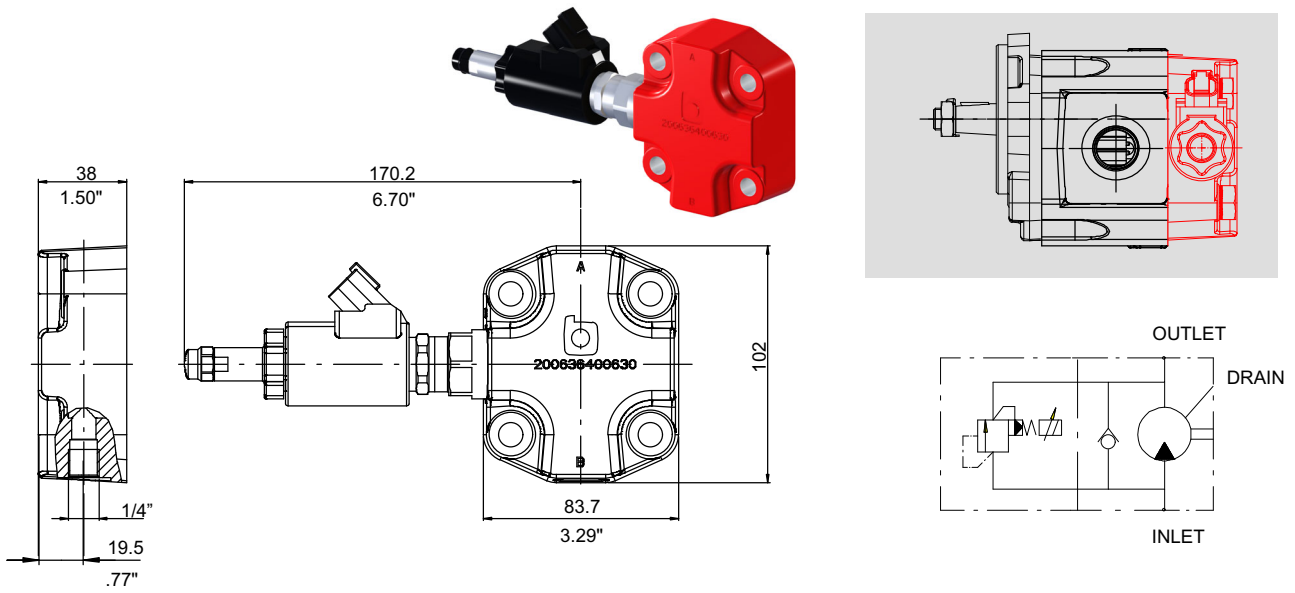

| | | | | | | | | | | | | | | | | | | | | | | | | | | | | | |
|---|---|---|---|---|---|---|---|---|---|---|---|---|---|---|---|---|---|---|---|---|---|---|---|---|---|---|---|---|---|
| A | P | M | R | 2 | 1 | 2 | H | P | / | 8 | , | 5 | - | D | - | A | 6 | S | - | 1 | C | - | D | 2 | 3 | A | 1 | + | C |
|---|---|---|---|---|---|---|---|---|---|---|---|---|---|---|---|---|---|---|---|---|---|---|---|---|---|---|---|---|---|

D = Type of cast iron back cover/valve combination
 Back cover with "DC" cavity and proportional pressure-relief cartridge valve type ($Q_{max} = 120 \text{ l/min}$)

Inverse proportional pressure-relief cartridge, size 10, DBVSA-1CG (NBR seals)

23 = Pressure settings

Pressure range : 10 = 100 bar
 16 = 160 bar
 23 = 230 bar

For further settings value available please consult Bucher Hydraulics.



ATTENTION!
 To prevent any pressure surges, outlet port must be routed to tank with the least possible back-pressure. Any tank pressure acting at outlet port is additive to the pressure setting at the main inlet port.



IMPORTANT!
 Further note and characteristics available in the dedicated catalogue 400-P-587101-E

$p = f(I)$ Pressure adjustment characteristic ($Q = 5 \text{ l/min}$)

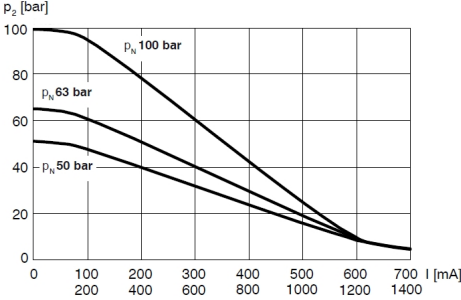

$p = f(I)$ Pressure adjustment characteristic ($Q = 5 \text{ l/min}$)

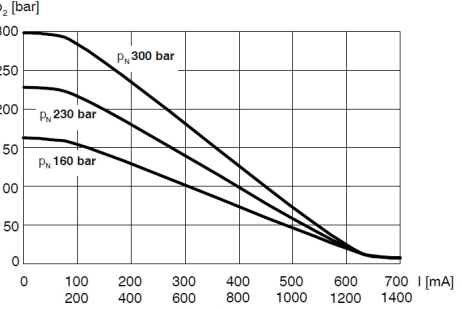

A = Solenoid connection type and nominal voltage

Connection type: DT AJ
 A = 12 V DC C = 12 V DC
 B = 24 V DC D = 24 V DC



IMPORTANT!
 To achieve the proportional pressure-relief cartridge's maximum performance rating, fit the solenoid coil as shown (with the plug pins at the top). When fitting the cartridges, note the mounting attitude (preferably vertical, with coil down automatic air bleed) and use the specified tightening torque. No adjustments are necessary, since the cartridges are set in the factory.

4 = Drain line port type

Drain line port:

| Thread | Tightening torque | Ordering code |
|----------|---------------------------|----------------|
| 1/4" BSP | 30_{+7}^{-6} Nm | 1 (standard) |
| M12x1.5 | 30_{+7}^{-6} Nm | 3 (on request) |
| SAE6 | 30_{+7}^{-6} Nm | 4 (on request) |

If the anticavitation valve integrated inside the motor is requested, please specify +C

3.7.10 Cast iron back cover with integrated valves: Proportional relief valve with ON-OFF reversible valve ($Q_{max} = 60 \text{ l/min}$)



IMPORTANT!

The inverse proportional pressure relief cartridge valve has to be completely open before to switch the Directional Control valve.

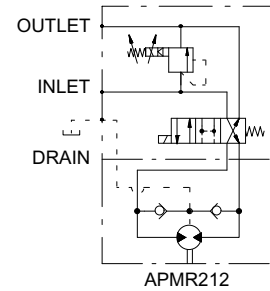
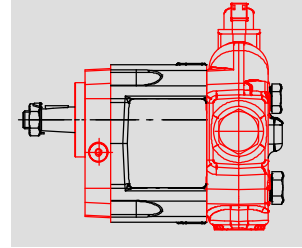
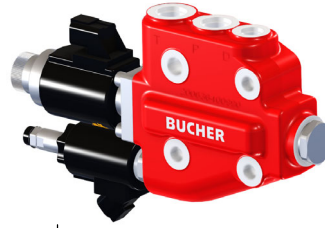
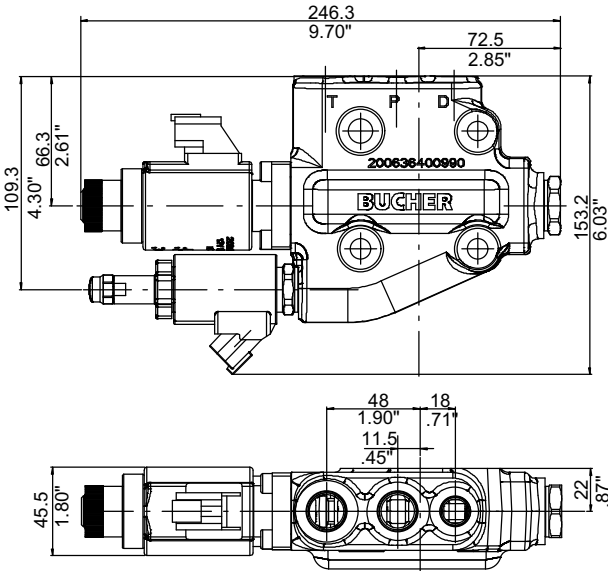

| | | | | | | | | | | | | | | | | | | | | | | | | | | | | | |
|---|---|---|---|---|---|---|---|---|---|---|---|---|---|---|---|---|---|---|---|---|---|---|---|---|---|---|---|---|---|
| A | P | M | R | 2 | 1 | 2 | H | P | / | 1 | 5 | - | A | 6 | S | - | 0 | - | C | 2 | 3 | A | 3 | R | + | C | F | - | D |
|---|---|---|---|---|---|---|---|---|---|---|---|---|---|---|---|---|---|---|---|---|---|---|---|---|---|---|---|---|---|

C = Type of cast iron back cover/valve

Back cover with "AL" cavity and proportional pressure-relief cartridge valve type $Q_{max} = 60 \text{ l/min}$

Inverse proportional pressure-relief cartridge, size 5, DBVSA-1LG (NBR seals)

23 = Pressure settings



ATTENTION!

To prevent any pressure surges, outlet port must be routed to tank with the least possible back-pressure. Any tank pressure acting at outlet port is additive to the pressure setting at the main inlet port.

Pressure range: 10 = 100 bar

16 = 160 bar

23 = 230 bar

For further settings value available please consult Bucher Hydraulics.

$p = f(I)$ Pressure adjustment characteristic ($Q = 5 \text{ l/min}$)

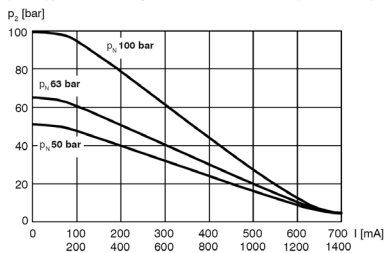

For further characteristics see catalogue: 400-P-586101-E



IMPORTANT!

Further note available in the dedicated catalogue: 400-P-586101-E

$p = f(I)$ Pressure adjustment characteristic ($Q = 5 \text{ l/min}$)

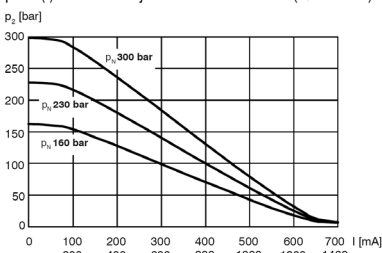

A = Solenoid connection type and nominal voltage

DT AJ

A = 12 V DC C = 12 V DC

B = 24 V DC D = 24 V DC



IMPORTANT!

To achieve the proportional pressure-relief cartridge's maximum performance rating, fit the solenoid coil with the plug pins at the top. When fitting the cartridges, note the mounting attitude (preferably vertical, with coil down automatic air bleed) and use the specified tightening torque. No adjustments are necessary, since the cartridges are set in the factory.

| Port type | Ordering code | Inlet/outlet threads | Tightening torque | Drain thread | Tightening torque |
|------------|---------------|----------------------|------------------------|--------------|------------------------|
| 3 = | 1 (Metric) | M18x1.5 | 60_0^{+5} Nm | M12x1.5 | 30_0^{+5} Nm |
| | 3 (SAE) | SAE8 | 60_0^{+5} Nm | SAE6 | 30_0^{+5} Nm |
| | 4 (BSPP) | 1/2" BSPP | 60_0^{+5} Nm | 1/4" BSPP | 30_0^{+5} Nm |

Directional control valve
33 Watt - 12V
Connector type:
DT04-2P ED 100%

Anticavitation valve integrated inside the front cover is requested, please specify +CF

Primary rotation with solenoid OFF
D = Right-hand rotation (CW) - S = left-hand rotation (CCW)



IMPORTANT! This circuit must be combined with front cover in cast iron, anticavitation valves included (see section 3.7.4)

3.7.11 Cast iron back cover with drain port with integrated valve: Double antishock-anticavitation valves (fixed setting) with ON-OFF reversible valve ($Q_{max} = 60$ l/min)

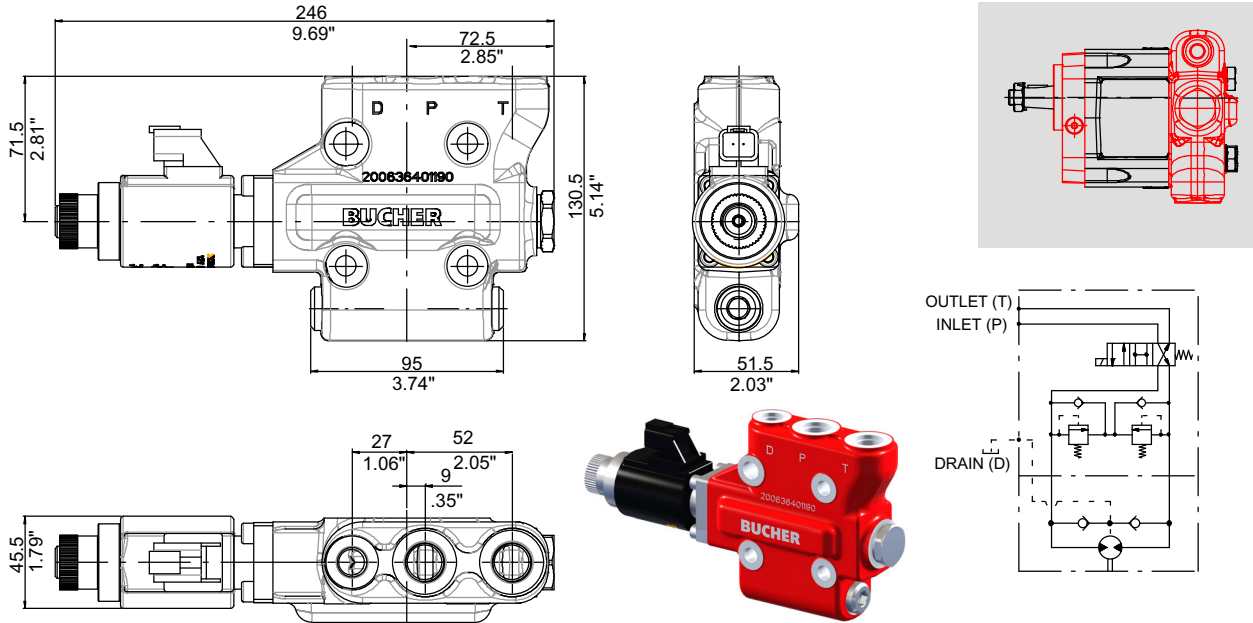

A P M R 2 1 2 H P / 1 5 - A 6 S - 0 - V 2 1 - 3 R + C F - D

V = Type of cast iron back cover/valve

| Pressure setting bar (PSI) | Valve code only | Ordering code |
|----------------------------|-----------------|---------------|
| 110 (1590) | 200533930110 | 11 |
| 120 (1740) | 200533930085 | 12 |
| 130 (1880) | 200533930057 | 13 |
| 140 (2030) | 200533930059 | 14 |
| 150 (2170) | 200533930051 | 15 |
| 160 (2320) | 200533930067 | 16 |
| 170 (2460) | 200533930071 | 17 |
| 180 (2610) | 200533930056 | 18 |
| 190 (2750) | 200533930113 | 19 |
| 200 (2900) | 200533930060 | 20 |
| 210 (3040) | 200533930080 | 21 |
| 220 (3190) | 200533930064 | 22 |
| 230 (3330) | 200533930058 | 23 |
| 240 (3480) | 200533930081 | 24 |
| 250 (3620) | 20053393052 | 25 |

21 = two antishock-anticavitation valves with the same setting

Anticavitation valve integrated inside the front cover is requested, please specify +CF

Primary rotation with solenoid OFF
D= Right-hand rotation (CW) - S = left-hand rotation (CCW)

For different pressure settings please consult Bucher Hydraulics.

| Ordering code | Inlet/outlet threads | Tightening torque | Drain thread | Tightening torque |
|-------------------|----------------------|----------------------------------|--------------|----------------------------------|
| 1 (Metric) | M18x1.5 | 60 ⁺⁵ ₀ Nm | M12x1.5 | 30 ⁺⁵ ₀ Nm |
| 3 (SAE) | SAE8 | 60 ⁺⁵ ₀ Nm | SAE6 | 30 ⁺⁵ ₀ Nm |
| 4 (BSPP) | 1/2" BSPP | 60 ⁺⁵ ₀ Nm | 1/4" BSPP | 30 ⁺⁵ ₀ Nm |

3 = Port type

Directional control valve
33 Watt - 12V
Connector type:
DT04-2P ED 100%

IMPORTANT! This circuit must be combined with front cover in cast iron, anticavitation valves included (see section 3.7.4)

4 Accessories

4.1 Electronic module, ESLF series

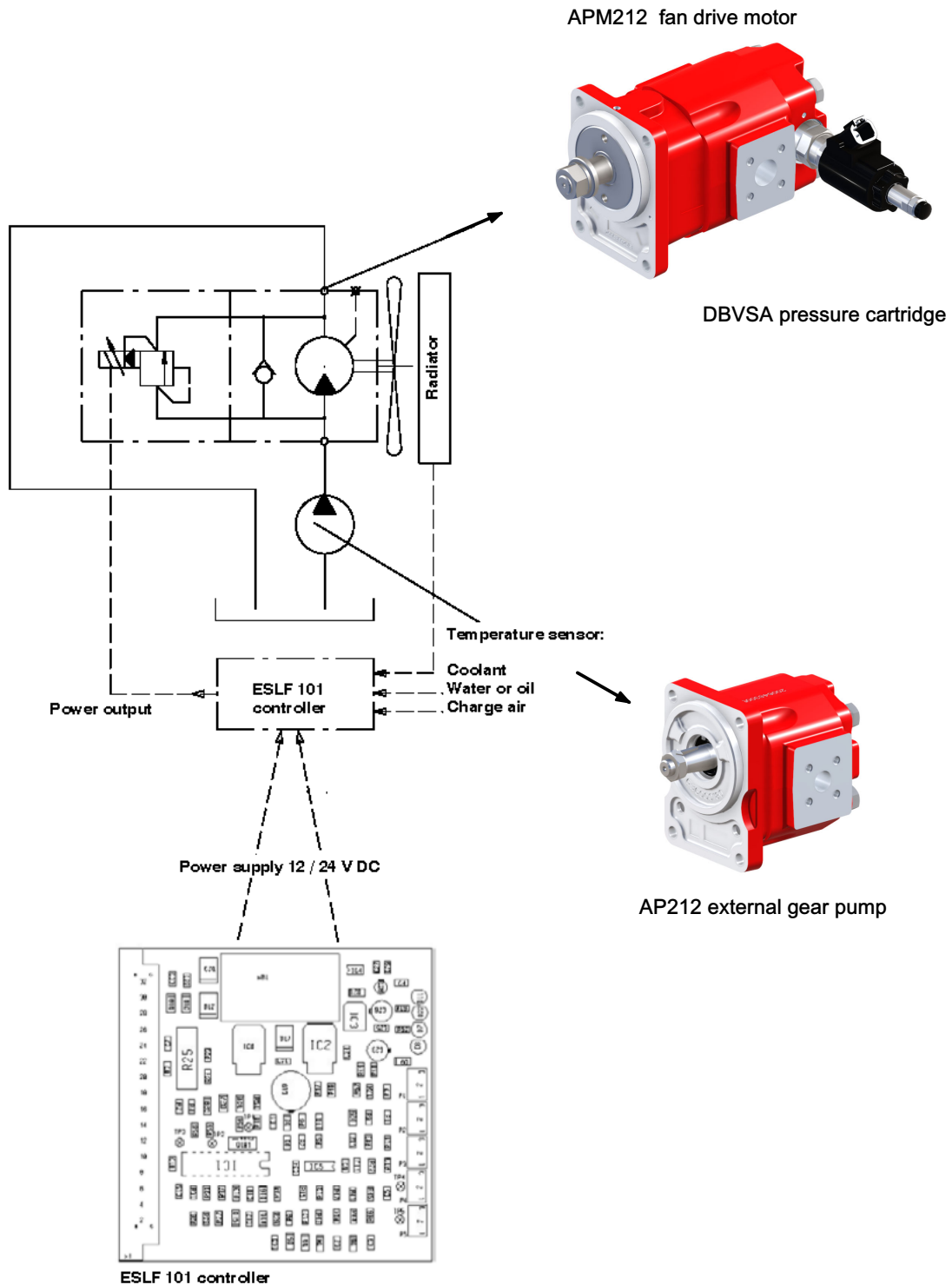

- Up to 3 temperature sensor can be used
- PTC and NTC sensor can both be used

- Same electronic system for reversible and non-reversible motors
- Can be supplied with or without housing

| Control system features | |
|---|---|
| Power supply | 12 V - 30 V DC |
| Reference voltage | 8 V DC max. 20 mA |
| Temperature inputs | 3 (T1, T2, T3) |
| Temperature sensor processing (U sensor) | Either PTC or NTC per card, using two-wire method |
| Temperature control range | 0°C - 100°C |
| Setting type of sensor; adjustment | Diagnostics input online; calibration potentiometer for each sensor |
| Prop. solenoid output for fan motor -max. fan motor speed -min. fan motor speed | max. Output current $I_{max}= 2,1$ A minimum current $I_{max}= 0,2$ A maximum current (adjustable) $I_{max}= 2,1 - 1,4$ A via potentiometer |
| ON/OFF solenoid output | Max. output current 2.5 A |
| Diagnostics | LED for each solenoid output LEDs for control mode |
| Electrical connection | DIN 41612 Type D edge connector, or screw terminals |
| Type of protection | non-encapsulated and encapsulated models |
| Dimensions | 100 mm x 100 mm x 25 mm (W x H x D) |
| Temperature range | -20°C to +50°C |

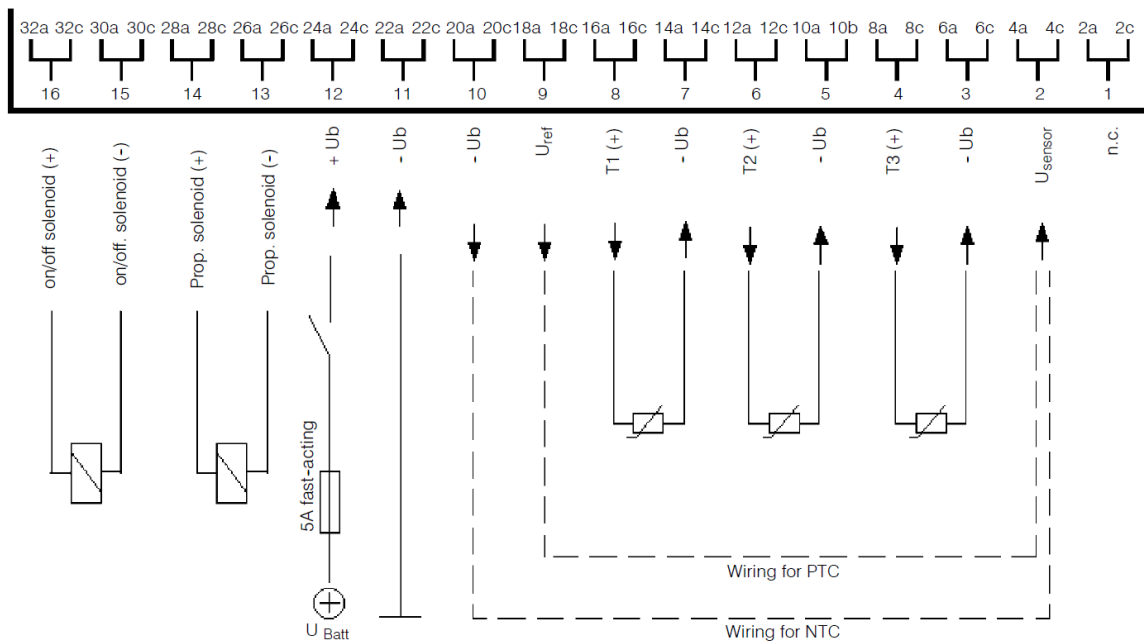

E S L F 1 0 1 - 8 1 * * *

Electronic fan drive controller, series ESLF

Encapsulated = 8

Non-encapsulated = 9

Screw terminals = 1

Edge connector = 0

Suitable for 12 V and 24 V DC

IMPORTANT! For detailed informations, see www.bucherhydraulics.com

4.2 External manifold for reversing control, STB series

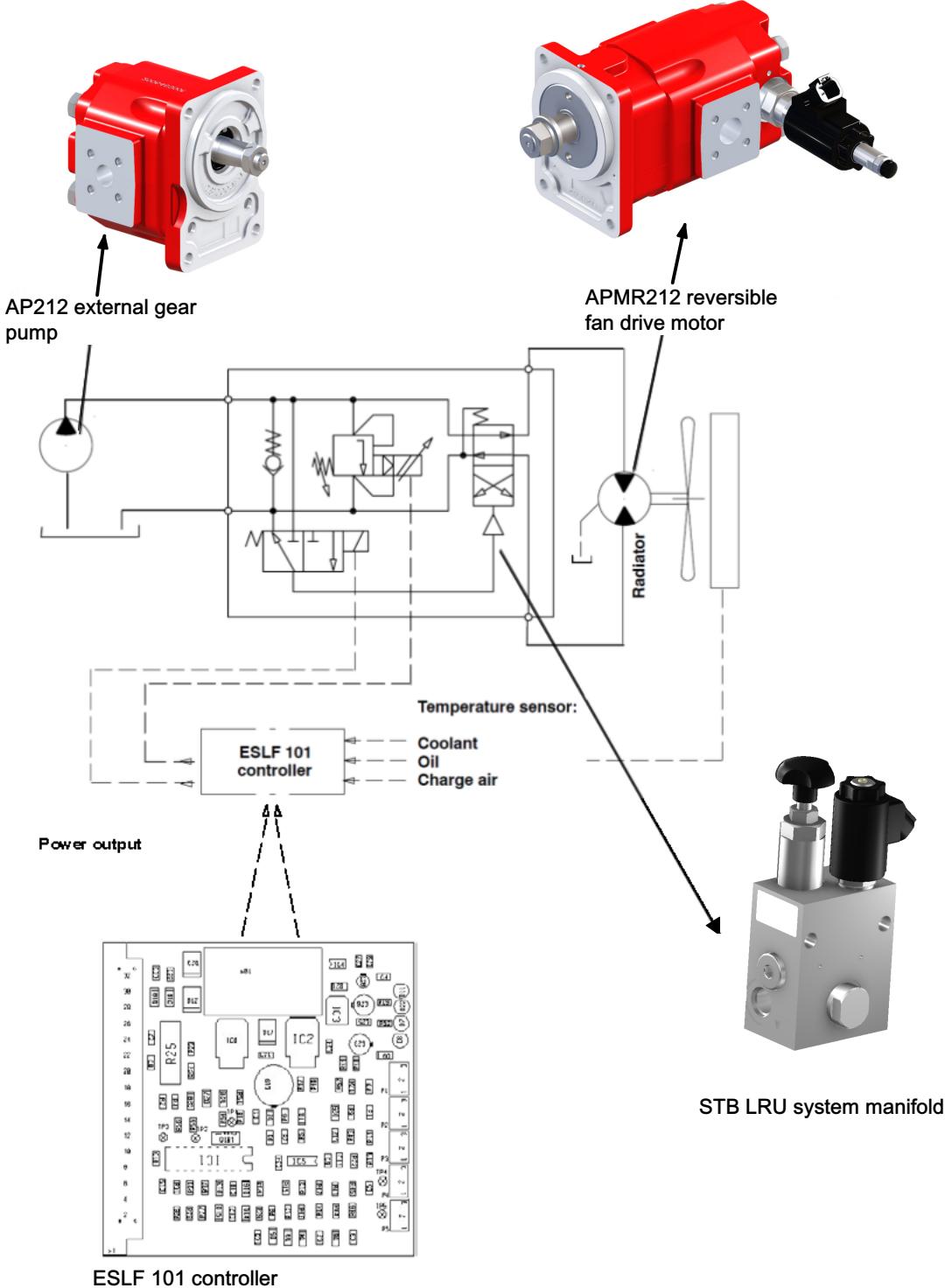

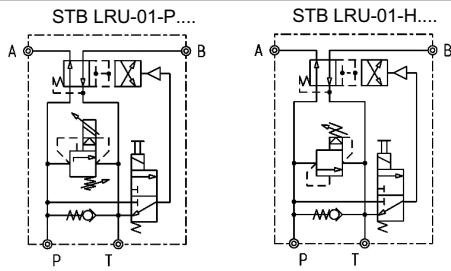

P_{max} = 250 bar
 Q_{max} = 50 l/min

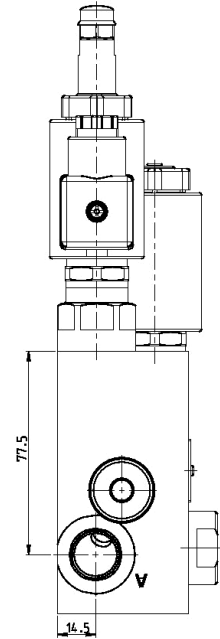
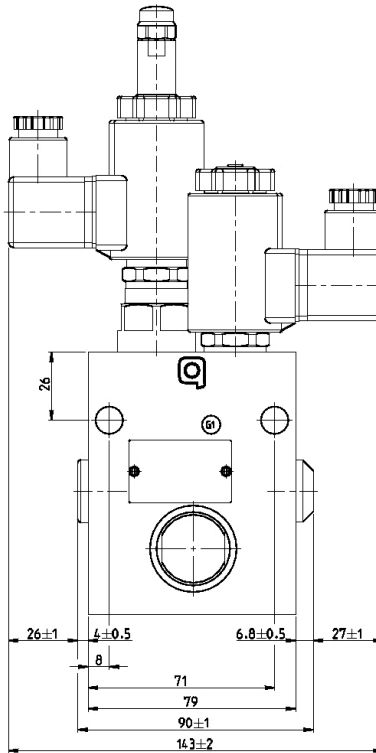
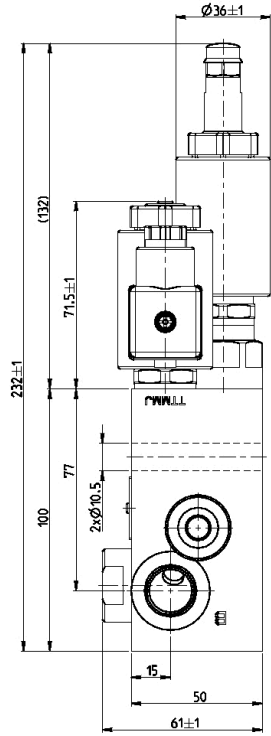
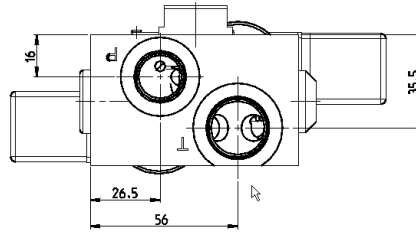

S T B L R U - 0 1 - P 1 6 M 0 6 0 9 1 2 V D C - -

System manifold series STB

With reversal of fan rotation, LRU

Design no.: 01

Pressure control valves:

P = Proportional, model DBVSA-1CG-...-10

H = manual adjustment, model DVPA-1-10...

W = electric model W UVPZ-1-10...

Pressure setting: 10 = 100 bar 16 = 160 bar 23 = 230 bar

| | | | |
|--------------|---------------------|------|-----------|
| | M | G | U |
| Port thread: | P / A / B = M18x1,5 | 3/8" | 3/4-16UNF |
| | T = M22x1,5 | 1/2" | 7/8-14UNF |

Nominal size 06 = 6 mm

Minimum flow for reversal switching 09 = 9 l/min

Voltage and current plainly specified: 12 V DC

24 V DC For others, contact Bucher Hydraulics

Solenoid coil connectors: Blank = with DIN 43650 / ISO 4400 (standard) J = Junior-Timer radial
M100 = without DIN Mating plug F = free cable ends / flying leads (length: 500 mm)
C = Kostal M27x1 I = Junior-Timer axial
D = Deutsch DT-2

T = with quenching diode P6KE33CA

IMPORTANT! For detailed informations, see www.bucherhydraulics.com

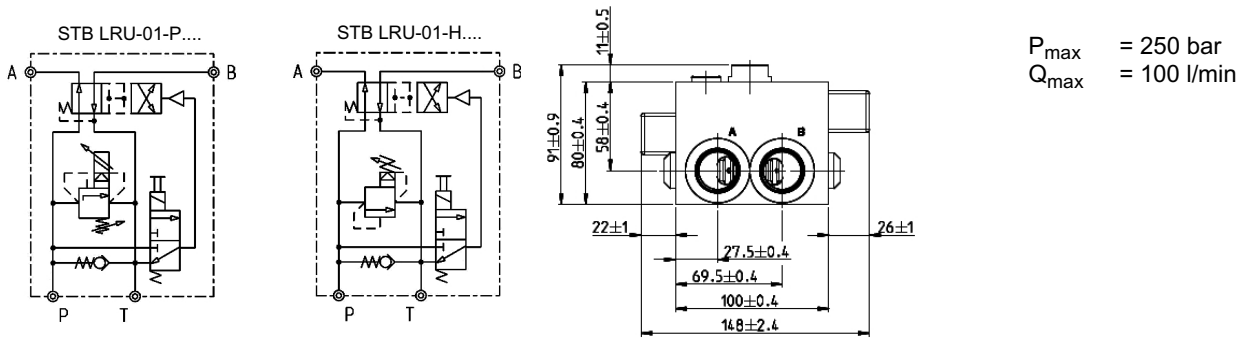

$P_{max} = 250 \text{ bar}$
 $Q_{max} = 100 \text{ l/min}$

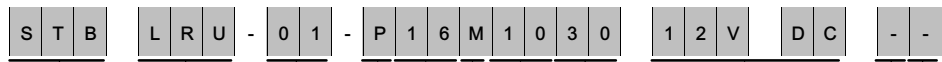
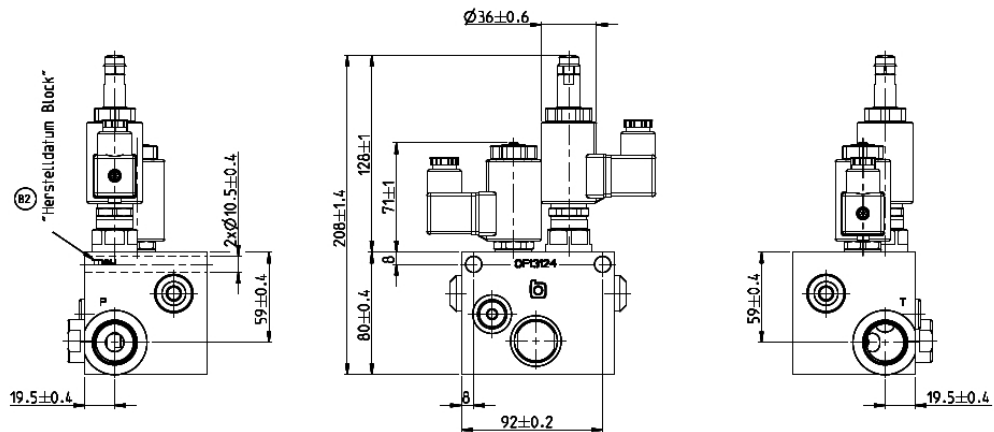

System manifold series STB

With reversal of fan rotation, LRU

Design no.: 01

Pressure control valves:

P = Proportional, model DBVSA-1CG-...-10

H = manual adjustment, model DVPA-1-10....

Pressure setting: 10 = 100 bar 16 = 160 bar 23 = 230 bar

Port thread: P / A / B = M26x1,5 3/4" 1 1/16-12UNF
 T = M26x1,5 3/4" 1 1/16-12UNF

Nominal size 10= 10 mm

Minimum flow for reversal switching 30= 30 l/min

Voltage and current plainly specified: 12 V DC
 24 V DC For others, contact Bucher Hydraulics

Solenoid coil connectors: Blank = with DIN 43650 / ISO 4400 (standard) J = with plug connectore Junior-Timer radial
 M100 = without DIN Mating plug F = free cable ends / flying leads (length: 500 mm)
 C = with plug connector Kostal

Quenching diode (specify if requested)

IMPORTANT! For detailed informations, see www.bucherhydraulics.com

5 Motors seal kit NBR + HNBR standard type

The seal Kit code includes:
OR and shaft seal

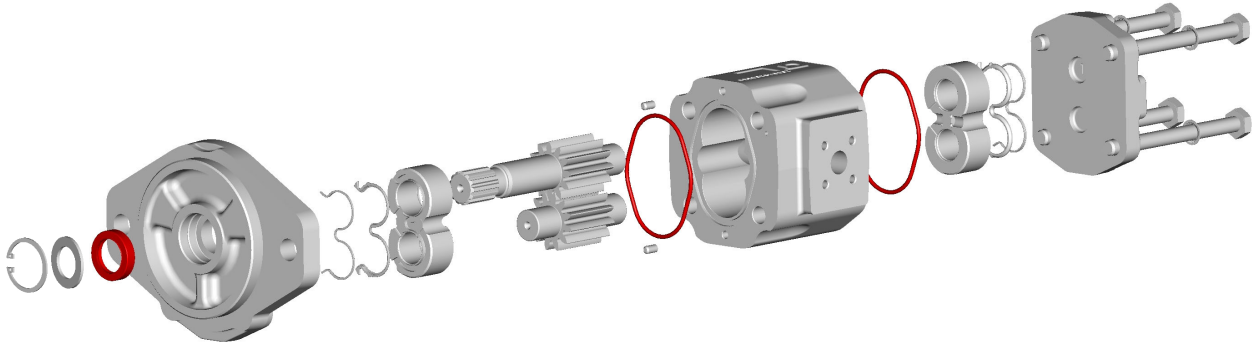

| Type | Code |
|--------|--------------|
| APM212 | 200974001560 |

Minimum kit order quantity is requested: please contact our Sales Center

6 Product identification plate

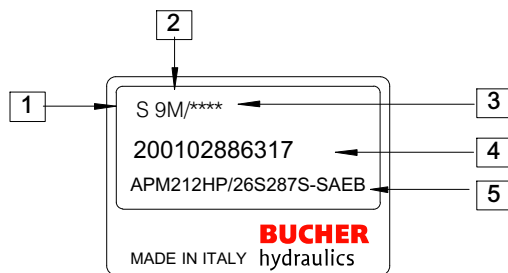

- 1 : Rotation
(D= Clockwise rotation - S= Counterclockwise rotation)
- 2 : Manufacturing year and month
- 3 : Progressive identification no. (optional)
- 4 : Bucher Hydraulics S.p.A. product +code
- 5 : Description

| Manufacturing month | Manufacturing year | | | | | | |
|---------------------|--------------------|------|------|------|------|------|------|
| | 2017 | 2018 | 2019 | 2020 | 2021 | 2022 | 2023 |
| January | 7A | 8M | 9M | 0M | 1M | 2M | 3M |
| February | 7B | 8N | 9N | 0N | 1N | 2N | 3N |
| March | 7C | 8P | 9P | 0P | 1P | 2P | 3P |
| April | 7D | 8Q | 9Q | 0Q | 1Q | 2Q | 3Q |
| May | 7E | 8R | 9R | 0R | 1R | 2R | 3R |
| June | 7F | 8S | 9S | 0S | 1S | 2S | 3S |
| July | 7G | 8T | 9T | 0T | 1T | 2T | 3T |
| August | 7H | 8U | 9U | 0U | 1U | 2U | 3U |
| September | 7I | 8V | 9V | 0V | 1V | 2V | 3V |
| October | 7J | 8Z | 9Z | 0Z | 1Z | 2Z | 3Z |
| November | 7K | 8X | 9X | 0X | 1X | 2X | 3X |
| December | 7L | 8Y | 9Y | 0Y | 1Y | 2Y | 3Y |

7 Application form

| | | | |
|----------------------------|--------------|-------------|---------|
| Date: | | | |
| Contact: | | | |
| Customer: | | | |
| Location: | | | |
| Overall quantity per year: | | | |
| Minimum batch size: | | | |
| Delivery time requested: | Feasibility: | Prototypes: | Series: |
| Target price: | | | |
| Type of application: | | | |

| External gear motor general data | | | | | |
|--|-----------|-----------|-----|-----------------------------------|-------------|
| Rotation | S | D | R | Speed range | |
| Displacement: Single motor (cm ³ /rev) | | | | Continuous work Pressure (bar) | 1st 2nd 3rd |
| Double motor (cm ³ /rev) | 1st | 2nd | | Peak work pressure (bar) | 1st 2nd 3rd |
| Multiple motor (cm ³ /rev) | 1st | 2nd | 3rd | Oil type | |
| Drive shaft | | | | Oil temperature (°C) | min max |
| Port type | | | | Oil viscosity (cSt) | min max |
| Front cover type | | | | Outlet line pressure | |
| Bearing support | | | | Voltage | |
| Front cover material | | | | Drain case pressure | |
| Intermediate cover (with or without shaft seal) | with | without | | Radial load (N) | |
| Back cover type/circuit | | | | Axial load (N) | |
| Back cover material | aluminium | cast iron | | Working hours per year | |
| Valves | | | | Cycles per year | |

Additional notes:

info.it@bucherhydraulics.com

www.bucherhydraulics.com

© 2020 by Bucher Hydraulics S.p.A, I-42124 Reggio Emilia

All rights reserved.

Data is provided for the purpose of product description only, and must not be construed as warranted characteristics in the legal sense. The information does not relieve users from the duty of conducting their own evaluations and tests. Because the products are subject to continual improvement, we reserve the right to amend the product specifications contained in this catalogue.

Classification: 430.110.000