

Internal Gear Motor

Series QXM12-Mobile and QXM22-Mobile

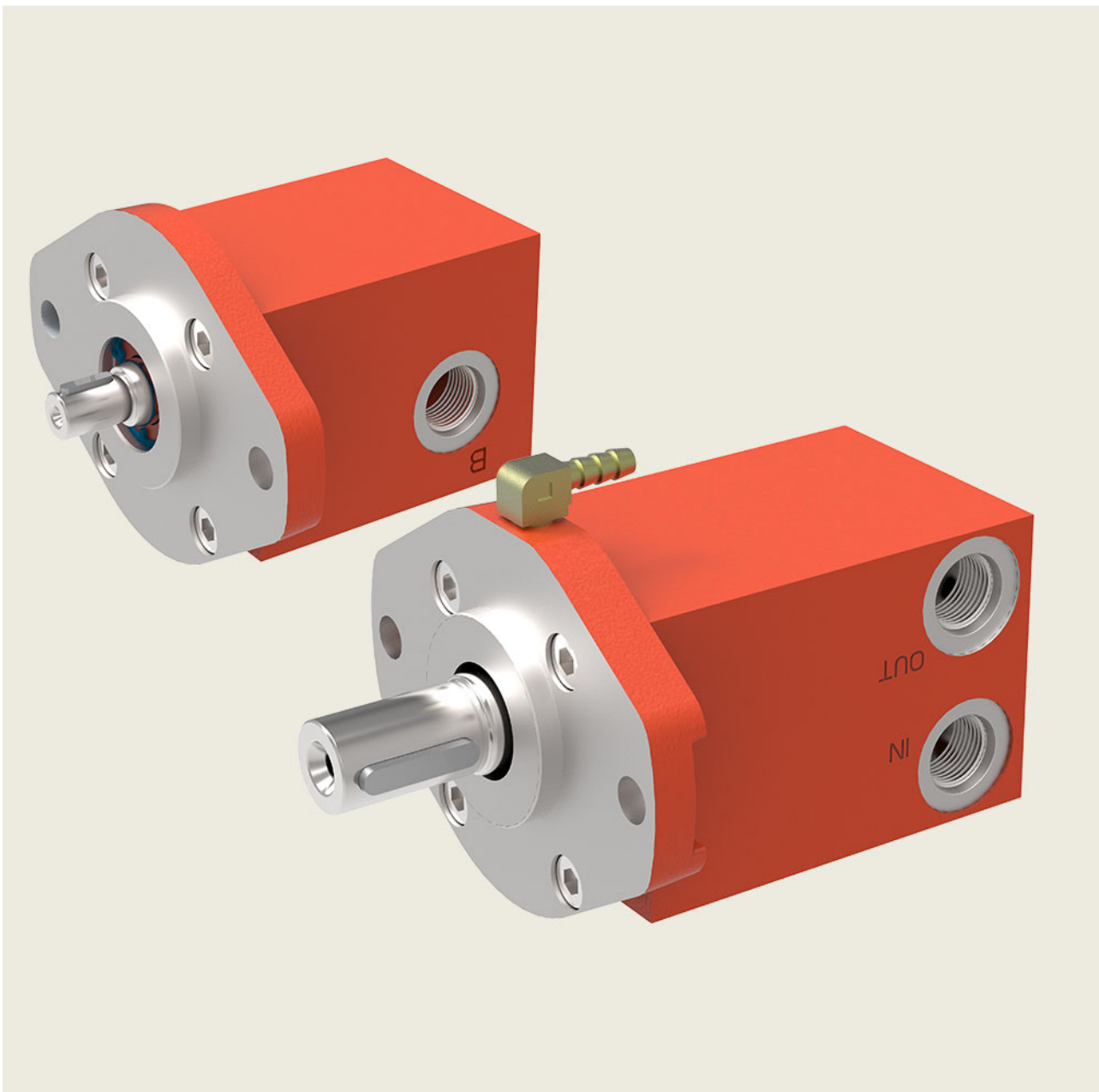

1800-OILSOL
1800-645765

<https://oilsolutions.com.au/>

sales@oilsolutions.com.au

Reference: 100-P-000162-EN-06

Contents

Page

1	General	5
	1.1 Product description	5
	1.2 Advantages	5
	1.3 External loads	5
	1.4 Application examples	5
2	Symbol	6
	2.1 QXM12-00..L-FAT9U34V5P1	6
	2.2 QXM12-00..R-FA12U34V5P1	6
	2.3 QXM22-00..R-SA22M22V5P6	6
	2.4 QXM22-00..L-KA22M22V5P2	6
	2.5 QXM22-00..R-KAT8U34V7P4	6
	2.6 QXM22-00..R-KA22M22V6P7	6
3	Technical data	7
	3.1 General	7
	3.2 Geometric displacement	7
4	Performance graphs	8
	4.1 Application limits for shaft seal	8
	4.2 Service life of ball bearing (outboard bearing)	8
	4.3 Noise level	9
	4.4 Efficiency	9
5	Dimensions	10
	5.1 QXM12-00..L-FAT9U34V5P1	10
	5.2 QXM12-00..R-FA12U34V5P1	10
	5.3 QXM22-00..R-SA22M22V5P6	11
	5.4 QXM22-00..L-KA22M22V5P2	11
	5.5 QXM22-00..R-KAT8U34V7P4	12
	5.6 QXM22-00..R-KA22M22V6P7	12
6	Versions	13
	6.1 Option	13
	6.2 Shaft seal	13
	6.3 Shaft end	13
	6.4 Ports	14
	6.5 Position of the threaded ports	14
7	Ordering information	15
	7.1 Model code	15
	7.2 Minimum order quantity	15

8	Notes on operation	16
	8.1 Temperature and viscosity	16
	8.2 Cold starting	16

9	Hydraulic fluid	16
---	-----------------------	----

10	Operational reliability	16
----	-------------------------------	----

11	Note	16
----	------------	----

1 General

1.1 Product description

The QXM-Mobile internal gear motor was specifically developed for use in mobile applications.

Its outstanding efficiency and extremely low noise levels also make a significant contribution to reducing the costs of both energy and anti-noise measures.

The QXM design principle, featuring an integral outboard bearing, ensures top-class protection against leakage at the shaft seal.

1.3 External loads

The QXM-Mobile features an integral heavy-duty outboard bearing for carrying external loads, both radial and axial.

Depending on the specific QXM-Mobile application, certain loads and duty cycles occur. To determine the service life of the anti-friction bearing, it is necessary to know the motor's loading profile and operating conditions. Please ask Bucher Hydraulics about the service life in your particular application.

1.4 Application examples

- Blower drives in general
- Blower drives in seed drills
- Generator drives in towed machines
- Fan drives
- Compressor drives
- Decentralised direct drives for cylinders
- Shipbuilding industry

1.2 Advantages

- Excellent torque characteristics even at high speed
- Sealing concept for ultra-high protection against external leakage
- Easy start, no „stick-slip-effect“
- Integral outboard bearing can carry high external loads

Examples of load-related operating conditions:

- Magnitude of the external shaft loading
- Direction of the external shaft loading
- Motor speed
- Viscosity of the hydraulic fluid
- Cleanliness of the hydraulic fluid

2 Symbol

2.1 QXM12-00..L-FAT9U34V5P1

With anti-cavitation valve and external drain port.

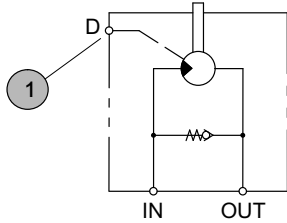

2.4 QXM22-00..L-KA22M22V5P2

With anti-cavitation valve and external drain port.

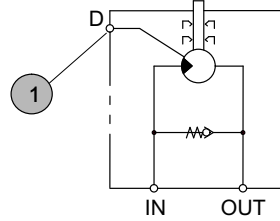

2.2 QXM12-00..R-FA12U34V5P1

With anti-cavitation valve and external drain port.

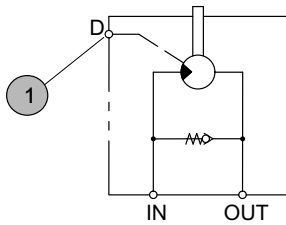

2.5 QXM22-00..R-KAT8U34V7P4

With pressure relief valve, anti-cavitation valve and external drain port.

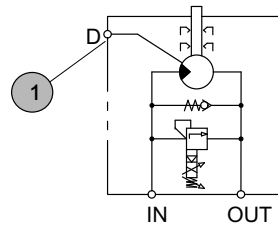

2.3 QXM22-00..R-SA22M22V5P6

With anti-cavitation valve, without external drain port.

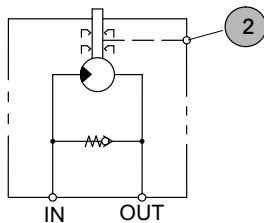

2.6 QXM22-00..R-KA22M22V6P7

With anti-cavitation valve, external drain port and speed sensor.

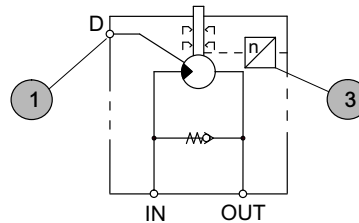

1	External drain port	3	Speed sensor
2	Fitting for hose		

3 Technical data

3.1 General

Main characteristics	Unit	Description, value
Mounting attitude		unrestricted
Mounting method		2-hole flange to ISO 3019/1 (SAE)
Direction of rotation		right (CW) or left (CCW)
Ports		IN and OUT: service ports, D: external drain port
Ports threads		metric : DIN 3852 Part 2 UNF 2B: ISO 11926-1
Hydraulic fluid		HLP mineral oils to DIN 51524 Part 2
Maximum permissible degree of contamination of the hydraulic fluid		class 20/18/15 to ISO 4406
Viscosity grades		VG32, VG46, VG68
Viscosity range	mm ² /s	10 ... 300 for operation under load maximum 4000 for starting, at a maximum of 4000 rpm
Hydraulic fluid temperature	°C	operation: -10 ... +100 = permissible +30 ... +60 = ideal minimum starting temperature -30
Total pressure IN port + OUT port	bar	250 dynamic 450 static

3.2 Geometric displacement

IMPORTANT: The operating data apply for mineral oils at 42 mm²/s.

Type	Displacement	Motor speed [rpm]		Operating pressure Maximum [bar]	Torque ²⁾ [Nm]
	(effective) [cm ³ /rev]	Maximum speed	Minimum speed ¹⁾		
QXM12-0025	2,5	6000	1500	210	8,3
QXM12-0030	3,0	6000	1500	210	10,0
QXM12-0035	3,5	6000	1500	210	11,7
QXM12-0040	4,1	6000	1500	210	13,4
QXM22-0050	5,1	6000	1500	210	16,7
QXM22-0063	6,3	6000	1500	210	20,0
QXM22-0080	8,0	6000	1500	210	26,7

1) For continuous operation at maximum operating pressure.

2) Theoretical value at maximum operating pressures.

4 Performance graphs

IMPORTANT: Measured with viscosity 42 mm²/s, speed 1450 rpm.

4.1 Application limits for shaft seal

Solid line = continuous pressure, dashed line = max. intermittent pressure

- 4.1.1 QXM12 permitted pressure:**
- at external drain port D
 - at port OUT for motors without external drain port

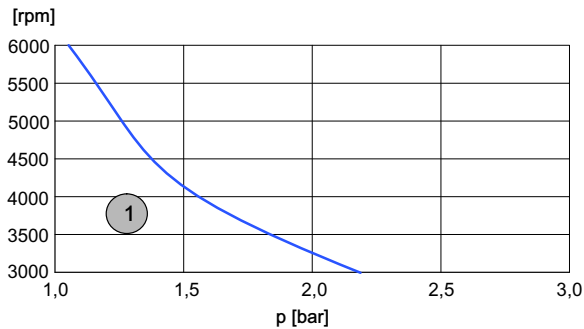

- 4.1.2 QXM22 permitted pressure:**
- at external drain port D
 - at port OUT for motors without external drain port

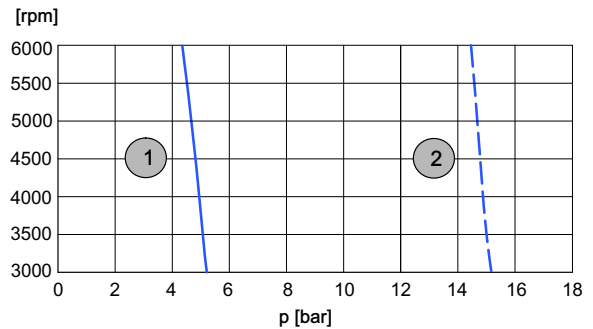

1	No leakage	2	Maximum expected leakage at the hose fitting (see Section 5.3.1): 50 ml in 100 hours
----------	------------	----------	--

4.2 Service life of ball bearing (outboard bearing)

Permissible radial force at the shaft end for a service life of 1500 hours; is dependent on axial force, speed and axial distance of radial force.

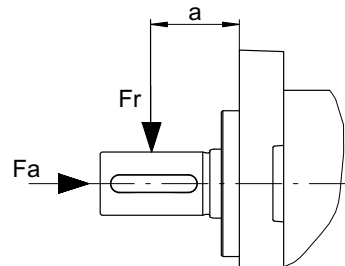

- 4.2.1 QXM12**
Lh = 1500 h / Fa = 200 N

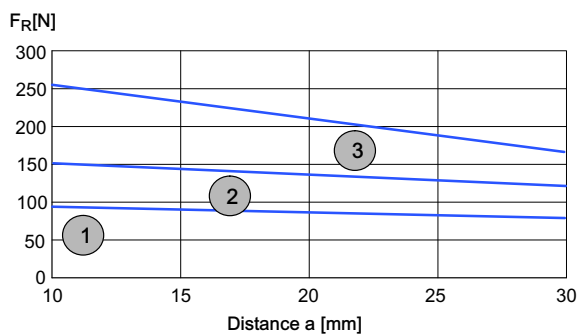

1	5000 rpm
2	3000 rpm
3	1500 rpm

- 4.2.2 QXM22**
Lh = 1500 h / Fa = 500 N

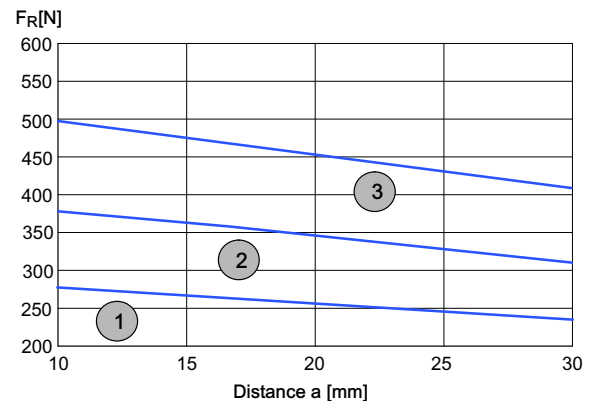

1	5000 rpm
2	3000 rpm
3	1500 rpm

4.3 Noise level

IMPORTANT: Measurement distance 1 m; viscosity = 42 mm²/s.

4.3.1 QXM12

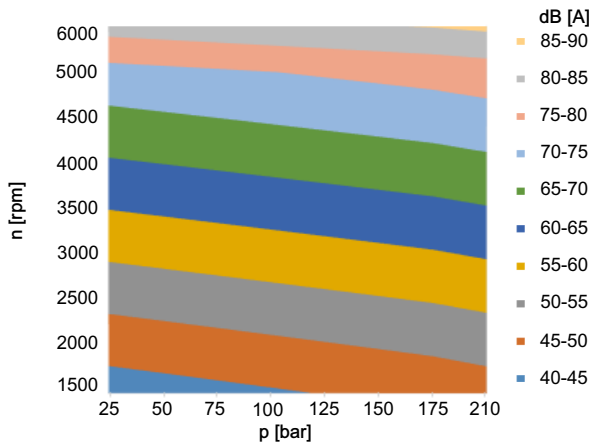

4.3.2 QXM22

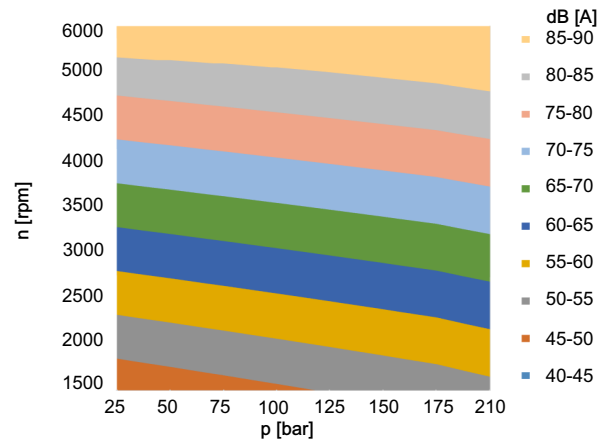

4.4 Efficiency

Legend for sections 4.4.1 - 4.4.4

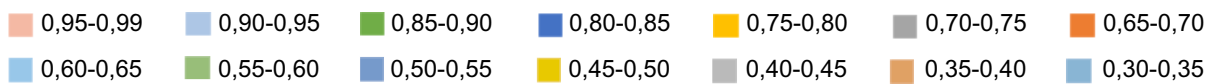

4.4.1 QXM12 Hydromechanical efficiency

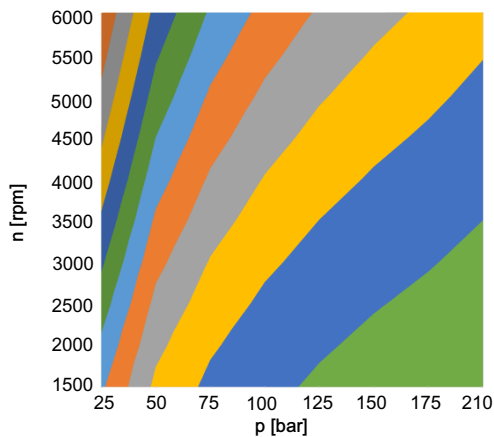

4.4.2 QXM12 Volumetric efficiency

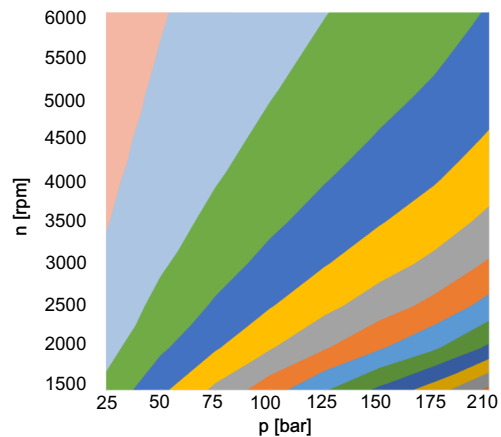

4.4.3 QXM22 Hydromechanical efficiency

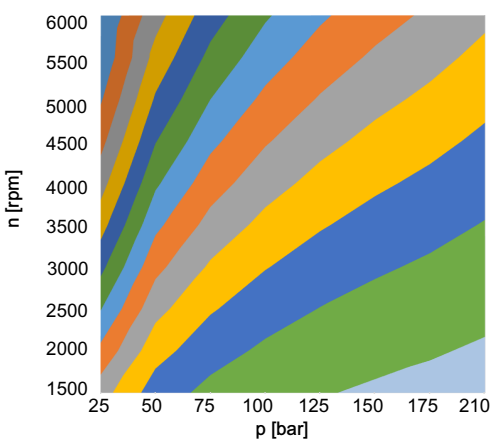

4.4.4 QXM22 Volumetric efficiency

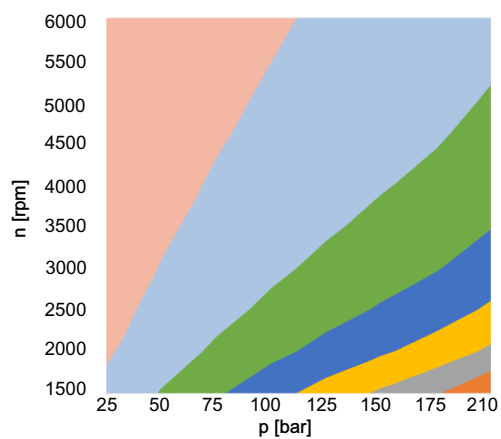

5 Dimensions

5.1 QXM12-00..L-FAT9U34V5P1

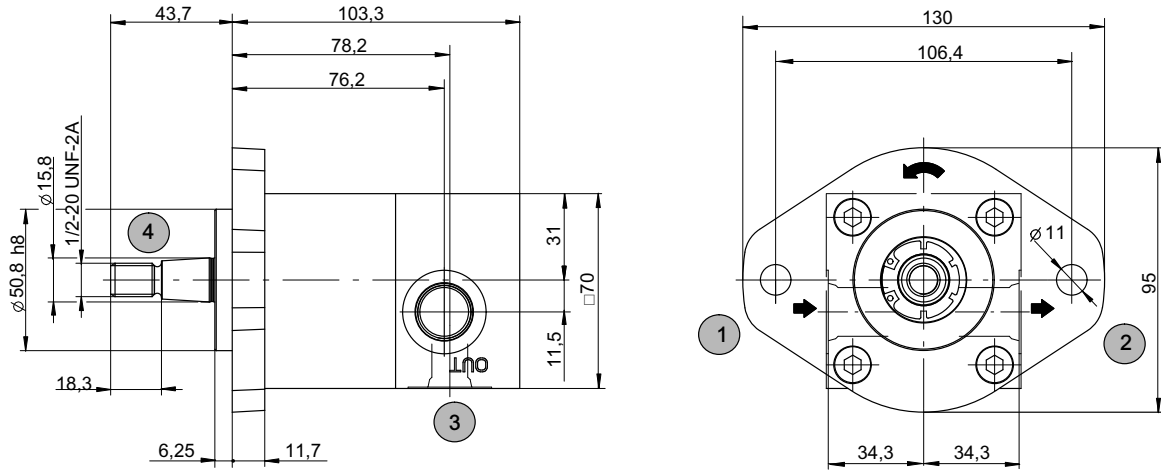

1	IN: 3/4-16 UNF-2B	3	External drain port D: 9/16-18 UNF-2B
2	OUT: 3/4-16 UNF-2B	4	Tapered shaft end 1:8

5.2 QXM12-00..R-FA12U34V5P1

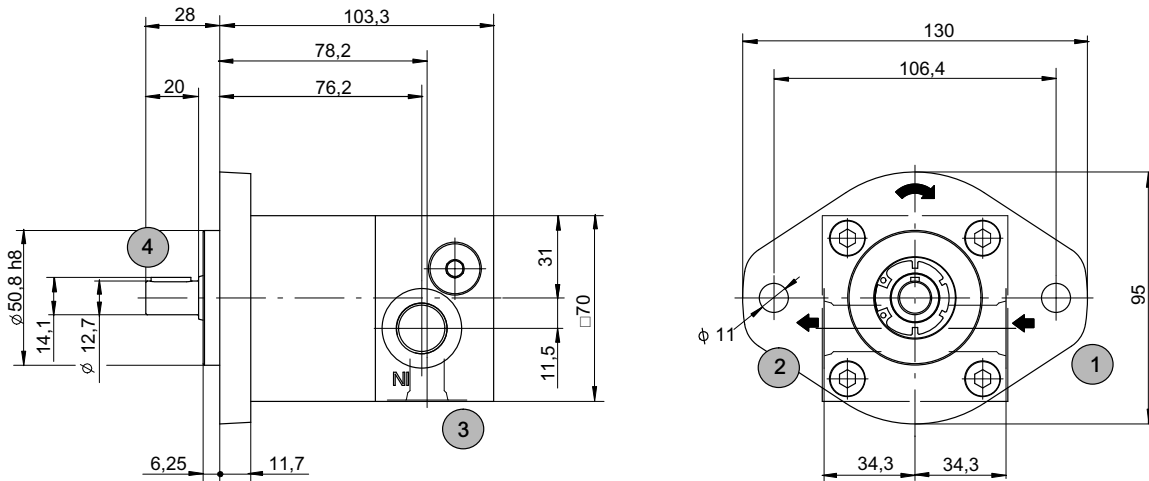

1	IN: 3/4-16 UNF-2B	3	External drain port D: 9/16-18 UNF-2B
2	OUT: 3/4-16 UNF-2B	4	Cylindrical shaft end $\varnothing 12,7$, key DIN 6885, 3,2x4x15

5.3 QXM22-00..R-SA22M22V5P6

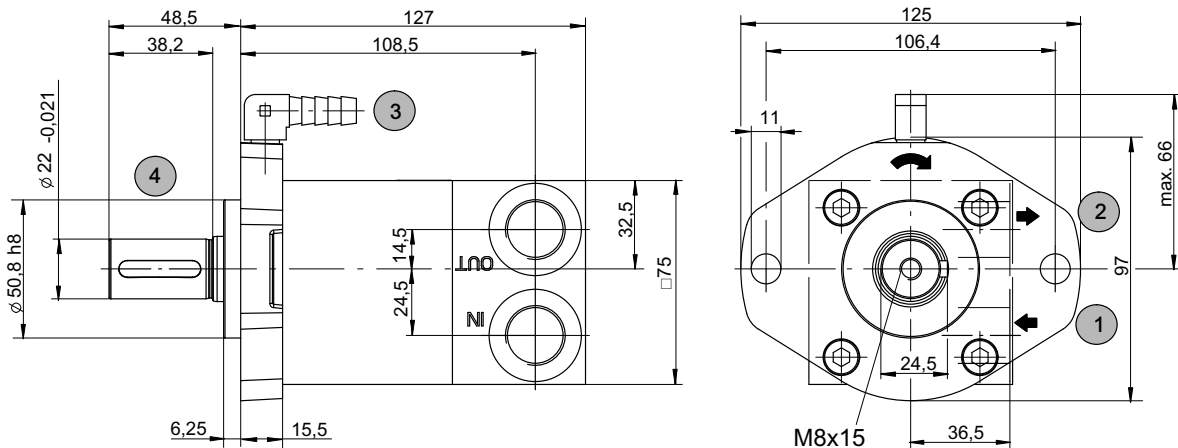

1	IN: M22x1,5	3	Connection for leakage oil safety tell-tale (see section 5.3.1)
2	OUT: M22x1,5	4	Cylindrical shaft end $\phi 22$, key DIN 6885, 6x6x30

5.3.1 Connection for leakage oil safety tell-tale

Seal combination for ultra-high protection against external leakage.

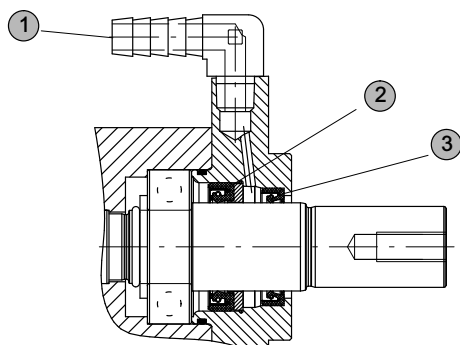

1	Fitting for hose with inside diameter 10 mm
2	Primary radial shaft seal ring
3	Secondary radial shaft seal ring

5.4 QXM22-00..L-KA22M22V5P2

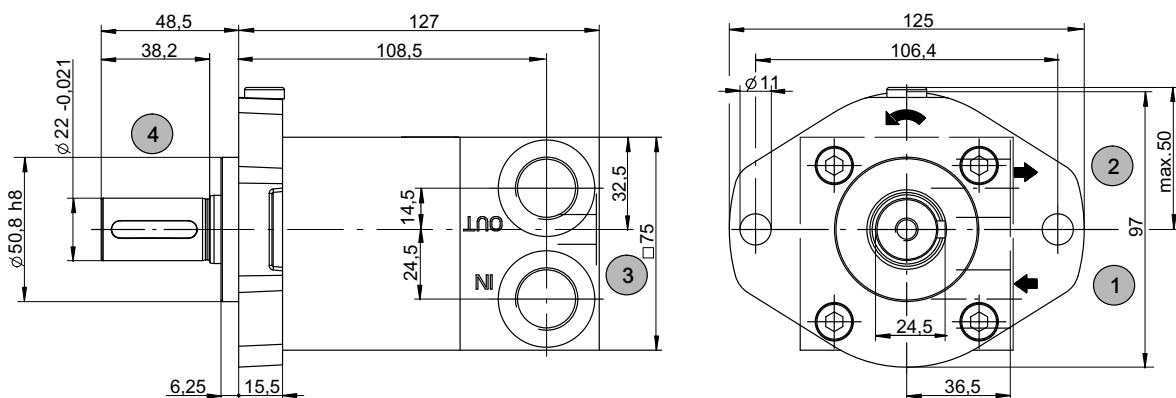

1	IN: M22x1,5	3	External drain port D: M12 x 1,5
2	OUT: M22x1,5	4	Cylindrical shaft end $\phi 22$, key DIN 6885, 6x6x30

5.5 QXM22-00..R-KAT8U34V7P4

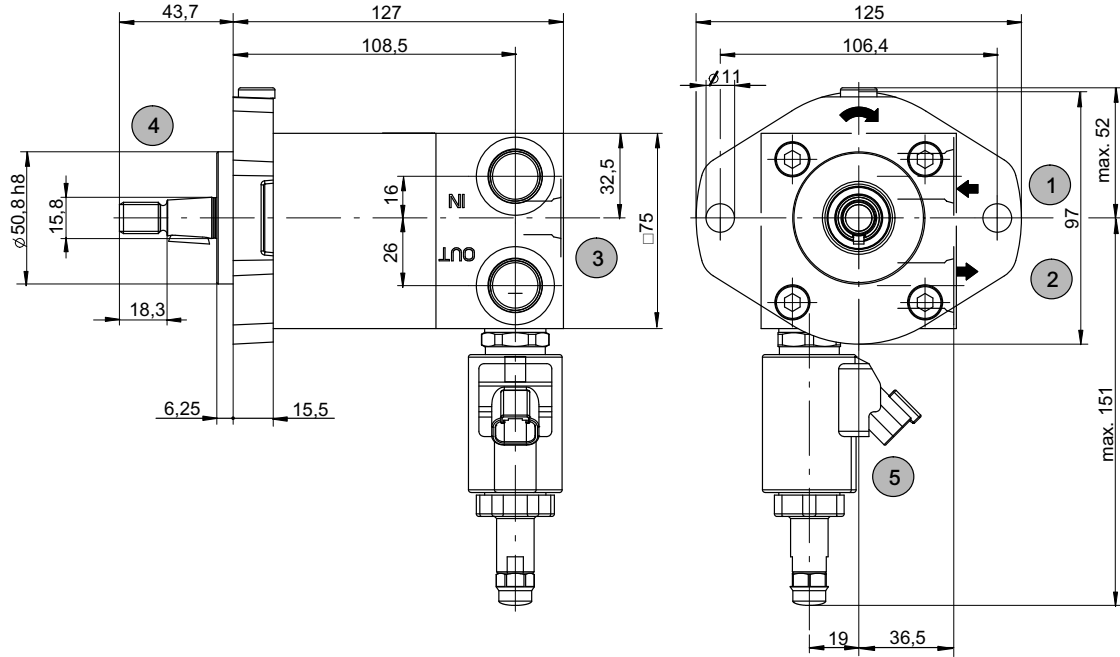

1	IN: 3/4-16 UNF-2B	4	Tapered shaft end 1:8, woodruff key DIN 6888, 4 x 6,5
2	OUT: 3/4-16 UNF-2B	5	Inverse pressure relief valve
3	External drain port D: 9/16-18UNF-2B		

5.6 QXM22-00..R-KA22M22V6P7

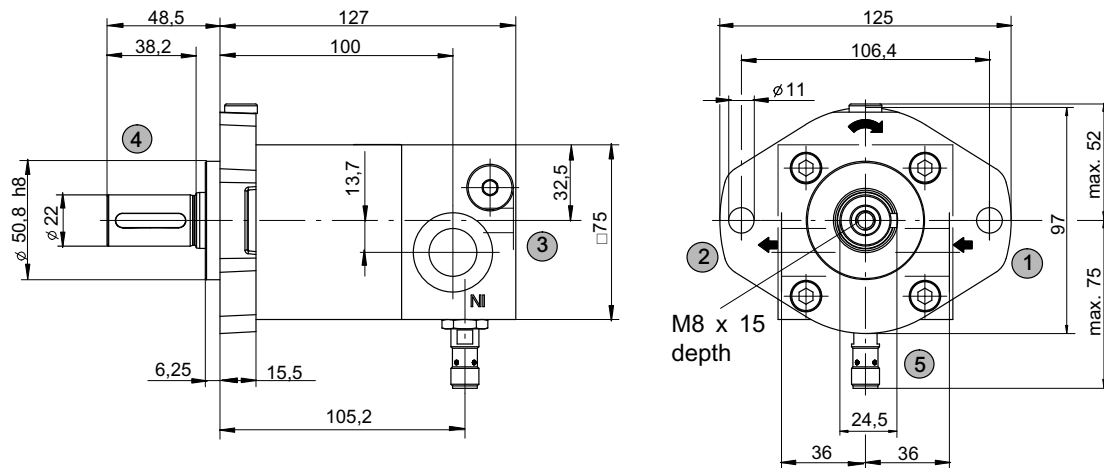

1	IN: M22x1,5	4	Cylindrical shaft end Ø22, key DIN 6885, 6x6x30
2	OUT: M22x1,5	5	Speed sensor: Plug: M12x1, 4-pole Pulses: 4 per revolution Voltage: U _B 10 ...36 V DC
3	External drain port D: M12x1,5		

6 Versions

IMPORTANT: Not all of the individual variants listed below can be combined. Before ordering, discuss your choices with your Bucher Hydraulics advisor.

6.1 Option

The standard version includes an integral make-up check valve and an external leakage drain connection. The additional functions of speed sensor and inverse pressure relief are also integrated (see section 2.5 and 2.6).

Option	Size 1	Size 2
Anti-cavitation valve with external drain port (standard)	V5	V5
Anti-cavitation valve without external drain port	-	V5
Standard + speed sensor	V6	V6
Standard + inverse pressure relief valve	V7	V7

The additional function determines the orientation of the ports.
Possible versions:

Orientation of the ports	Size 1	Size 2
Anti-cavitation valve with external drain port (standard)	P1	P2
Anti-cavitation valve without external drain port	-	P6
Standard + speed sensor	P7	P7
Standard + inverse pressure relief valve	P4	P4

6.2 Shaft seal

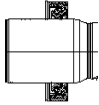
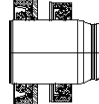
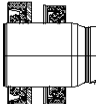
Version	Shaft seal quantity	Size 1	Size 2
	1	F	-
	2	-	K
	2	-	S 1)

1) See section 5.3.1.

6.3 Shaft end

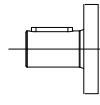
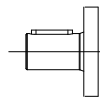
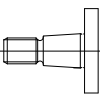
Version	Size 1	Size 2
 Cylindrical Ø12,70	12	-
 Cylindrical Ø22	-	22
 Tapered 1:8	T9	T8

6.4 Ports

Port threads		Size 1	Size 2
IN / OUT:	3/4-16 UNF-2B	U34	U34
Drain line D:	9/16-18 UNF-2B		
IN / OUT:	M22 x 1,5	-	M22
Drain line D:	M12 x 1,5		

6.5 Position of the threaded ports

Symbol	Direction of rotation	Size 1	Size 2
	Left (CCW)	P1	-
	Right (CW)	P1	-
	Left (CCW)	-	P2
	Right (CW)	-	P2
	Left (CCW)	-	P4
	Right (CW)	-	P4
	Left (CCW)	-	P6
	Right (CW)	-	P6
	Left (CCW)	P7	P7
	Right (CW)	P7	P7

7 Ordering information

7.1 Model code

	QXM	1	2	-	0035	R	-	F	A	T9	U34	V5	P1
Type Internal gear unit QXM-Mobile													
Size													
Pressure range													
Displacement [cm ³ /rev]													
2,5 = 0025			5,1										
3,0 = 0030			6,3										
3,5 = 0035			8,0										
4,1 = 0040													
Direction of rotation													
Right													
Left													
Shaft seal (see section 6.2)													
size 1: One shaft seal													
size 2: Two shaft seals													
size 2: 2 shaft seals and fitting for hose (see section 5.3.1)													
Mounting flange													
SAE-A(A), 2-hole flange, centering spigot Ø 50,8 = A													
Shaft end (see section 6.3)													
Cylindrical Ø 12,70													
Cylindrical Ø 22													
Tapered 1:8													
Tapered 1:8 with woodruff key													
Ports (see section 6.4)													
IN / OUT: 3/4-16 UNF-2B													
External drain port: 9/16-18 UNF-2B													
IN / OUT: M22x1,5													
External drain port: M12x1,5													
Options (see section 6.1)													
Anti-cavitation valve with external drain port (standard)													
Anti-cavitation valve without external drain port													
Standard + speed sensor													
Standard + inverse pressure relief valve													
Position of the threaded ports (see section 6.5)													
P1 / P2 / P4 / P6 / P7													

7.2 Minimum order quantity

The manufacturing processes for the QXM12-Mobile and QXM22-Mobile internal gear motors are based on the latest methods for large-scale production.

So that we can integrate your order into this manufacturing process economically, we need a minimum order quantity of 300 motors/year and a minimum batch size of 25 units.

8 Notes on operation

8.1 Temperature and viscosity

The temperature of the fluid in the system should not exceed 100 °C.

At operating temperature, the viscosity of the hydraulic fluid must not be less than 10 mm²/s, and when starting the motor it must not be more than 4000 mm²/s.

The motor must not be put under load until the operating viscosity has been reached.

To ensure that QXM motors can achieve a long service life, temperature shocks must be avoided.

8.2 Cold starting

Much of the damage to hydraulic motors happens in the first few minutes after a cold start. To ensure the long service life of the motor, it is particularly important that it is not subjected to pressures > 100 bar and speeds > 4000 rpm during the cold-start phase.

9 Hydraulic fluid

The oil for QXM-Mobile motors must have a minimum cleanliness class of 20/18/15 to ISO 4406. We recommend the use of fluids that contain anti-wear additives for operation with boundary lubrication. Fluids without appropriate additives reduce the service life of the motors. The user is responsible for maintaining, and regularly checking, the fluid quality.

10 Operational reliability

For the reliable operation and long service life of QXM-Mobile internal gear motors, a maintenance plan must be prepared for the power unit, the machine or the plant. This must ensure that the permissible operating conditions of the motors are maintained throughout their working life.

In particular, compliance with the following operating parameters must be ensured:

- the specified oil cleanliness
- the operating temperature range

In addition, the motor and the system must be inspected at regular intervals for any changes in the following characteristics:

- vibrations
- noise
- temperature difference: motor - fluid in the tank
- leak-tightness

Changes in these characteristics indicate wear, for example in the system components. The cause must be immediately pinpointed and eliminated.

11 Note

This catalogue is intended for users with specialist knowledge. The user must check the suitability of the equipment described herein in order to ensure that all of the conditions necessary for the safety and proper functioning of the system are fulfilled. If you have any doubts or questions, please consult Bucher Hydraulics.