

# **Auburn Gear**

Engineered Drive Solutions



≡ Power Wheel ≡

≡ Model 3 TWISTOTOW® ≡



OIL SOLUTIONS

PO Box 38  
Strathfieldsaye, VIC, 3551  
1800 OIL SOL  
1800 645 765

[sales@oilsolutions.com.au](mailto:sales@oilsolutions.com.au)

[www.oilsolutions.com.au](http://www.oilsolutions.com.au)

"For All Your Hydraulic Needs"

# Power Wheel Model 3 TWISTOTOW®

## Feature Chart: Model 3 TWISTOTOW®

| OPTIONS               | DESCRIPTION                   | MAKE ALL SELECTIONS IN ONE COLUMN | ORDER CODES | USE OPTION ORDER CODES TO BUILD ORDER NUMBER |
|-----------------------|-------------------------------|-----------------------------------|-------------|----------------------------------------------|
| BASE MODEL            | Model 3 TwisToTow®            | . . . .                           | 3T2         | 3T2                                          |
| MOTOR PILOT/HUB       | SAE A-4 Bolt Magneto          | . . . .                           | A4F         | A4F                                          |
|                       | SAE B-2 Bolt                  | . . . .                           | BF          |                                              |
| INPUT SPLINE          | 13T 16/32                     | . . . .                           | 13          |                                              |
|                       | 14T 12/24                     | . . . .                           | 14          | 14                                           |
|                       | 1" 6B                         | . . . .                           | 15          |                                              |
| RATIO                 | 3.60:1                        | . . . .                           | 03          | 03                                           |
| SHAFT/SPINDLE OPTIONS | 5 thru holes on 4.50" B.C.    | . . . .                           | FD1         | FD1                                          |
|                       | (6) M14x1.5 thd on 110mm B.C. | . . . .                           | FD2         |                                              |
| SHAFT STUDS           | None                          | . . . .                           | 00          |                                              |
|                       | 1/2-20 x 1.62"                | . . . .                           | 26          | 26                                           |
|                       | 9/16-18 x 1.62"               | . . . .                           | 27          |                                              |

Example of complete order code: 3T2 A4F 14 03 FD1 26

## Bearing Life Curve

B10 life is based on 3,000 hours at 100 rpm

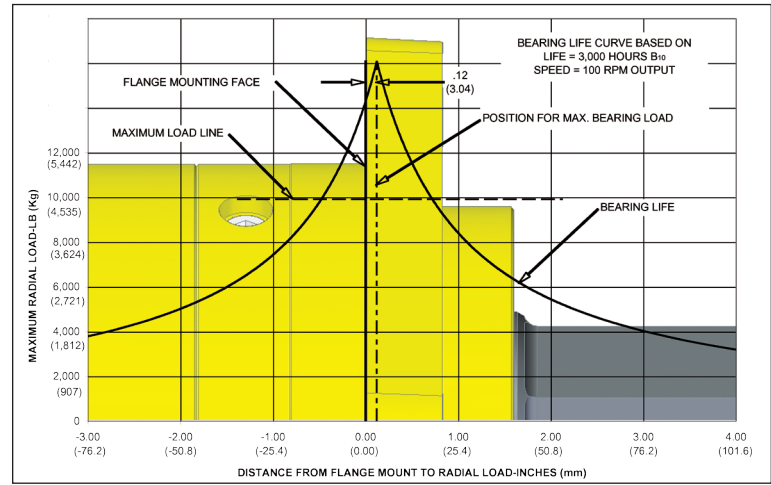

## Model 3 TWISTOTOW®

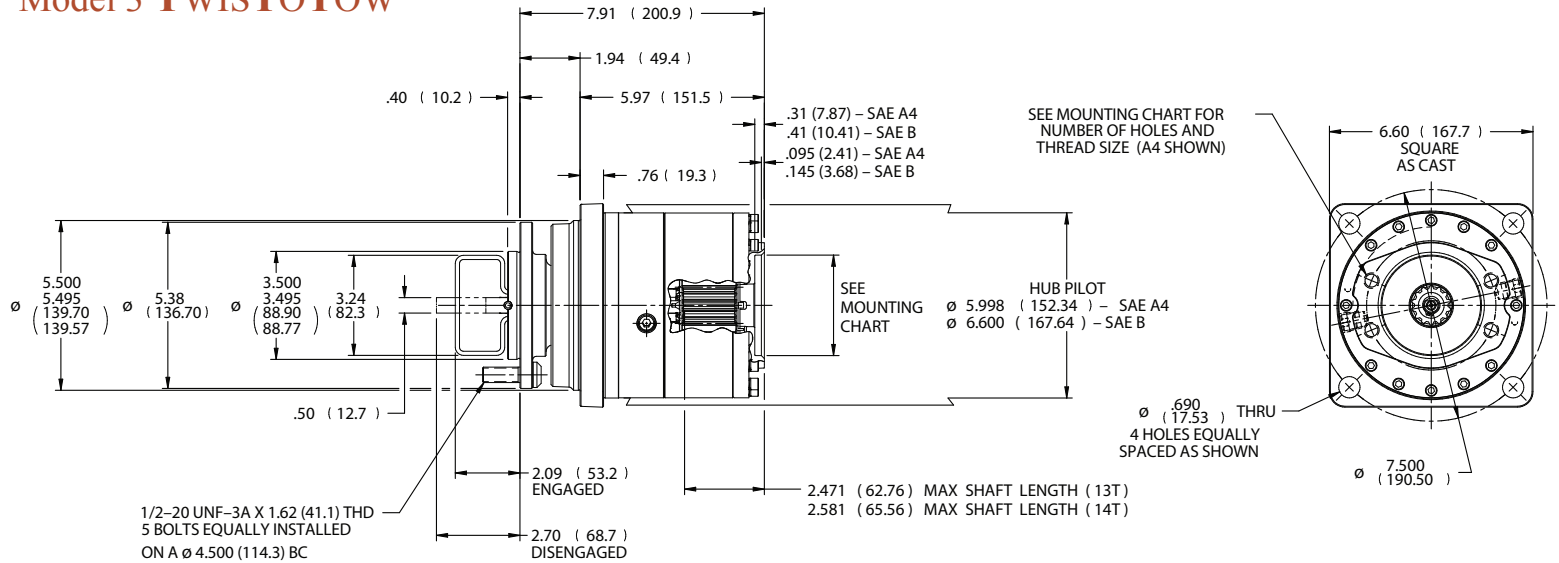

## Motor Mounting Chart

| SAE | # of Tapped Holes, Thread Size and Bolt Circle | Pilot Diameter                  |
|-----|------------------------------------------------|---------------------------------|
| A4  | (4) 1/2"-13 UNC-2B on a 4.187" (106.35mm) B.C. | 3.251"-3.256" (82.58-82.70mm)   |
| B   | (2) 1/2"-13 UNC-2B on a 5.75" (146.05mm) B.C.  | 4.001"-4.006" (101.62-101.75mm) |



1800-OILSOL  
1800-645765

<https://oilsolutions.com.au/>

[sales@oilsolutions.com.au](mailto:sales@oilsolutions.com.au)