

Auburn Gear

Engineered Drive Solutions



OIL SOLUTIONS

PO Box 38
Strathfieldsaye, VIC, 3551
1800 OIL SOL
1800 645 765
sales@oilsolutions.com.au
www.oilsolutions.com.au
"For All Your Hydraulic Needs"

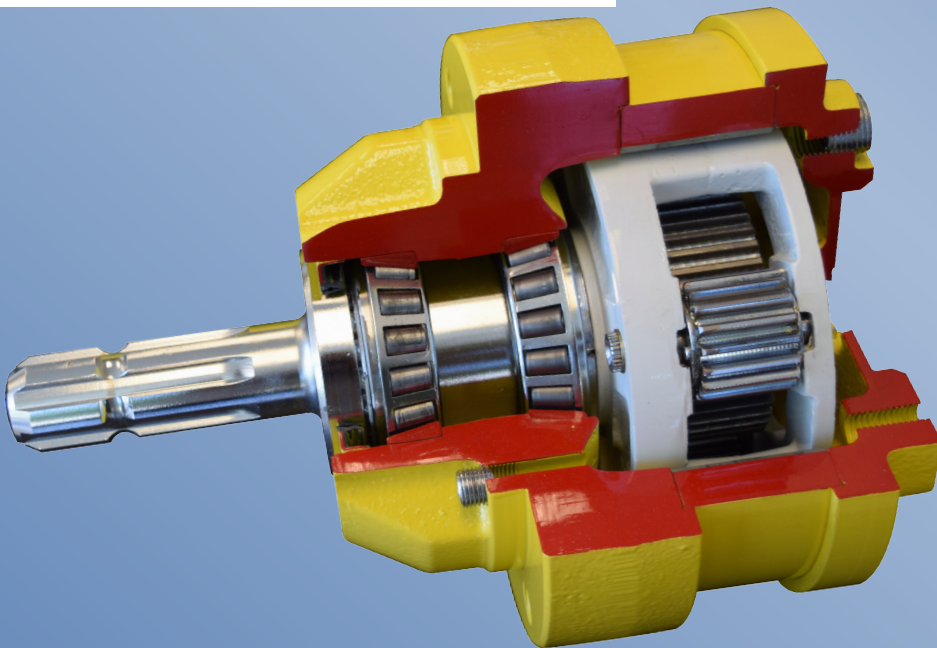
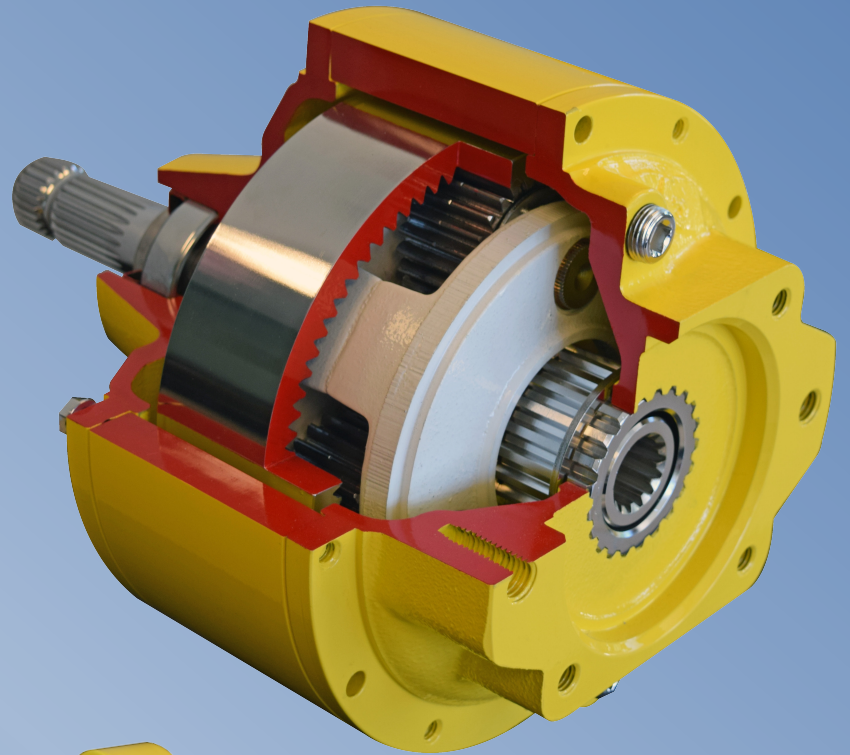

Power Wheel®

Model 8 PTO Drive

Power Wheel® Model 8 PTO Drive

FEATURE CHART: MODEL 8 PTO DRIVES

| Options | Description | Make All Selections In One Column | Order Codes | Use Option Order Codes to Build Order Number |
|----------------------------|----------------------|-----------------------------------|-------------|--|
| Base Model | Model 8 | • | 8F | 8F |
| Motor Pilot/Hub | SAE B – 2 Bolt | • | B1 | C1 |
| | SAE C – 2 and 4 Bolt | • | C1 | |
| | SAE C – 2 and 4 Bolt | • | C | |
| Input Spline | 13T 16/32 | • | 13 | 14 |
| | 14T 12/24 | • | 14 | |
| | 15T 16/32 | • | 15 | |
| Ratio Options | 1:2.92 | • | 02 | 02 |
| | 1:3.92 | • | 03 | |
| Input Shaft Options | 21T-1 3/8" Splined | • | A8 | K3 |
| | 2.00" Keyed | • | K1 | |
| | 1.75" Keyed | • | K3 | |

Example of complete order code: **8F C1 14 02 K3**

MOTOR MOUNTING CHART

| SAE | # of Tapped Holes, Thread Size and Bolt Circle | Pilot Diameter |
|----------|---|---------------------------------|
| B | (2) 1/2"-13UNC-2B on a 5.75" (146.05mm) B.C. | 1.001"-4.006" (101.62-101.75mm) |
| C | (4) 1/2"-13UNC-2B on a 6.375" (161.93mm) B.C. | 5.001"-5.006" (127.02-127.15mm) |
| | AND (2) 5.8"-11UNC-2B on a 7.125" (180.98mm) B.C. | |

8FB1, 8FC1

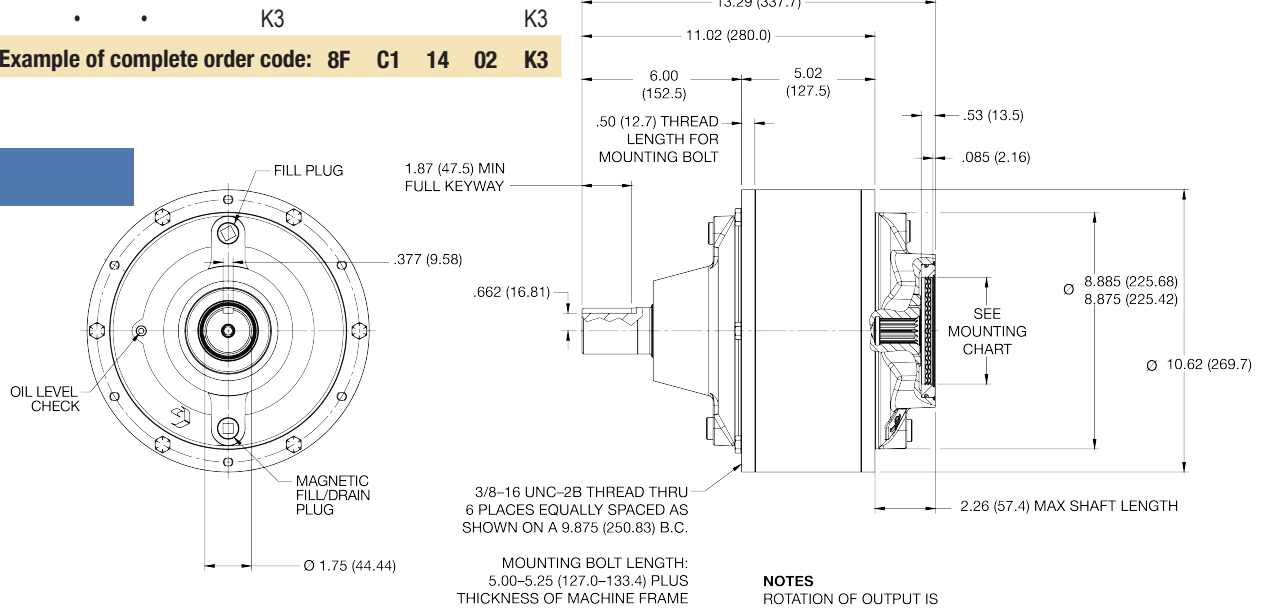

NOTES
ROTATION OF OUTPUT IS OPPOSITE OF INPUT ROTATION

5/8-11UNC-2B THREAD
1.25 (31.8) DEEP
6 HOLES EQUALLY SPACED
ON $\varnothing 6.750$ (171.45) BC

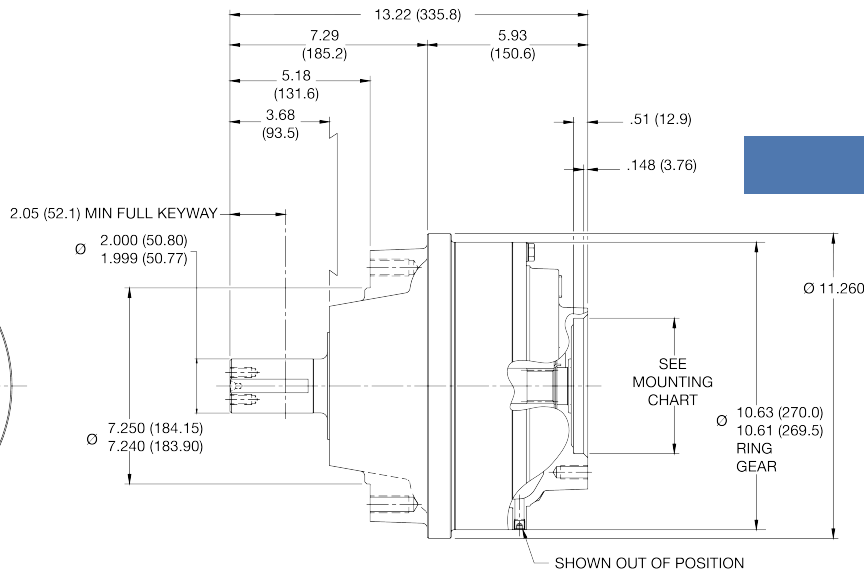

8FC

OUTPUT SHAFT ROTATION SAME AS MOTOR SHAFT ROTATION

MOTOR MOUNT REQUIRES CUSTOMER SUPPLIED O-RING SAE "C" 2-159



1800-OILSOL
1800-645765

<https://oilsolutions.com.au/>

sales@oilsolutions.com.au