

# AuburnGear

Engineered Drive Solutions



OIL SOLUTIONS

PO Box 38  
Strathfieldsaye, VIC, 3551  
1800 OIL SOL  
1800 645 765

[sales@oilsolutions.com.au](mailto:sales@oilsolutions.com.au)

[www.oilsolutions.com.au](http://www.oilsolutions.com.au)

"For All Your Hydraulic Needs"

## TWISToTOW®

Model 9 & Model 145 Spindle Output Drives w/ Air Brake System

260.925.3200

AuburnGear.com

### General Specifications

Max. intermittent output torque <sup>1,2</sup>	Max. input speed <sup>2</sup> .....	5,000 RPM
Model 9 .....	Approximate Weight .....	295 lbs (135 kg)
Model 145 .....	Oil Capacity .....	72 oz (2,130 cc)
	Max Radial Load (@pref. load center) .....	30,000 lbs (13,600kg)

<sup>1</sup> Depending on the duty cycle and the nature of the application, a normal continuous output torque of 1/3 to 1/2 of the maximum intermittent should yield satisfactory Power Wheel® life. Customer testing and application analysis is strongly recommended.

<sup>2</sup> If application exceeds published limit, contact Auburn Gear.

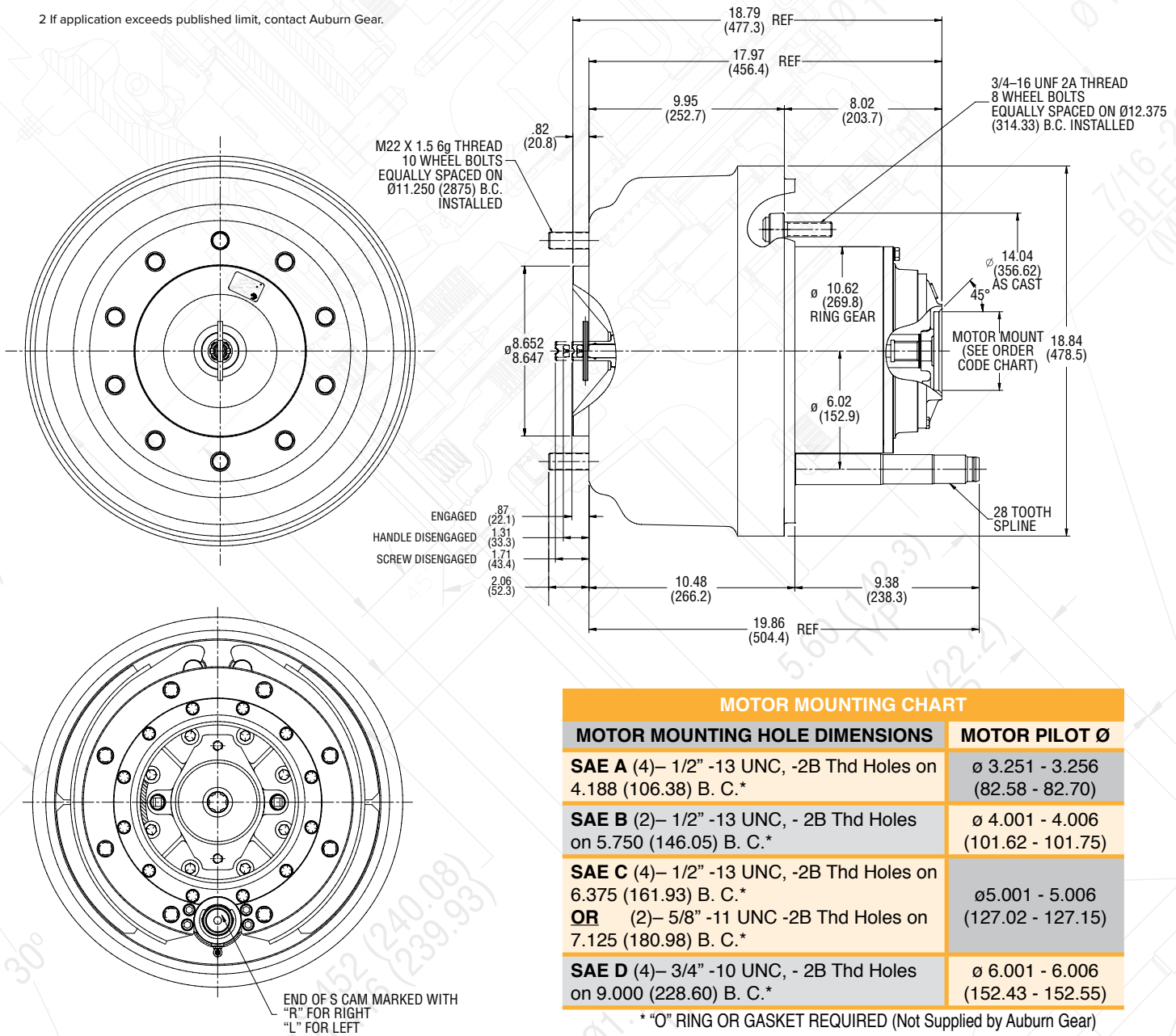

#### MOTOR MOUNTING CHART

MOTOR MOUNTING HOLE DIMENSIONS	MOTOR PILOT Ø
<b>SAE A</b> (4)– 1/2" -13 UNC, -2B Thd Holes on 4.188 (106.38) B. C.*	Ø 3.251 - 3.256 (82.58 - 82.70)
<b>SAE B</b> (2)– 1/2" -13 UNC, - 2B Thd Holes on 5.750 (146.05) B. C.*	Ø 4.001 - 4.006 (101.62 - 101.75)
<b>SAE C</b> (4)– 1/2" -13 UNC, -2B Thd Holes on 6.375 (161.93) B. C.*	Ø 5.001 - 5.006 (127.02 - 127.15)
<b>OR</b> (2)– 5/8" -11 UNC -2B Thd Holes on 7.125 (180.98) B. C.*	
<b>SAE D</b> (4)– 3/4" -10 UNC, - 2B Thd Holes on 9.000 (228.60) B. C.*	Ø 6.001 - 6.006 (152.43 - 152.55)

\* "O" RING OR GASKET REQUIRED (Not Supplied by Auburn Gear)

"O" RING SIZES: SAE "A" 2-042, SAE "B" 2-155, SAE "C" 2-159, SAE "D" 2-163



1800-OILSOL  
1800-645765

<https://oilsolutions.com.au/>

[sales@oilsolutions.com.au](mailto:sales@oilsolutions.com.au)

FEATURE CHART: MODEL 9 AND MODEL 145 TwisToTow® w/ air brake											
OPTIONS	DESCRIPTION	MAKE ALL SELECTIONS IN ONE COLUMN					ORDER CODES	USE OPTION ORDER CODES TO BUILD ORDER NUMBER			
BASE MODEL	Model 9	•	•	•	•	•	9S	9S			
	Model 145			•			145S				
MOTOR PILOT/HUB	A3	•					A3	A3			
	B3		•	•			B3				
	C3	•			•		C3				
	D3					•	D3				
INPUT SPLNE	13T 16/32		•				13				
	1" 6B			•			6B				
	14T 12/24	•					14	14			
	17T 12/24				•		17				
	13T 8/16					•	13				
RATIO OPTIONS (Contact AGI for 145 Ratio Availability)	15.39:1	•	•			•	15				
	18.83:1	•	•		•	•	18				
	23.59:1	•	•			•	23				
	26.71:1	•	•			•	26				
	31.50:1	•	•				31		31		
	35.20:1	•	•				35				
	42.42:1	•	•				42				
50.00:1	•	•				50					
HUB STUDS	None	•	•	•	•	•	00				
	3/4-16 X 3.21	•	•	•	•	•	11			11	
SPINDLE OPTIONS	(10) thru on a 11.250" BC	•	•	•	•	•	FD3			FD3	
SPINDLE STUDS	M22-1.5-6g x 105mm	•	•	•	•	•	28				28
"S" CAM SHAFT ORIENTATION	Right Hand	•	•	•	•	•	R				R
	Left Hand	•	•	•	•	•	L				

Example of complete order code: 9S A3 14 31 11 FD3 28 R

**BEARING LOAD, LIFE AND SPEED RELATIONSHIPS**

$LF = \frac{SF \times R}{R'}$

R = Allowable resultant load for given location from mounting flange  
R' = Anticipated load at location from mounting flange  
LF = Life Factor from table (see below)  
SF = Speed Factor from table (see below)

OUTPUT SPEED (RPM)	SF	LF	BEARING HOURS B-10 LIFE
5	2.456	.584	500
10	1.994	.719	1000
20	1.620	.812	1500
30	1.435	.886	2000
40	1.316	.947	2500
50	1.231	1.000	3000
60	1.165	1.047	3500
70	1.113	1.090	4000
80	1.069	1.130	4500
90	1.032	1.166	5000
100	1.000	1.231	6000
200	.812	1.289	7000
300	.719	1.342	8000
400	.659	1.390	9000
500	.617	1.435	10000

**CAUTION:** The same torsional loading constraints used in the driving mode must be used in the braking mode when braking through the **Power Wheel** drive gear set.

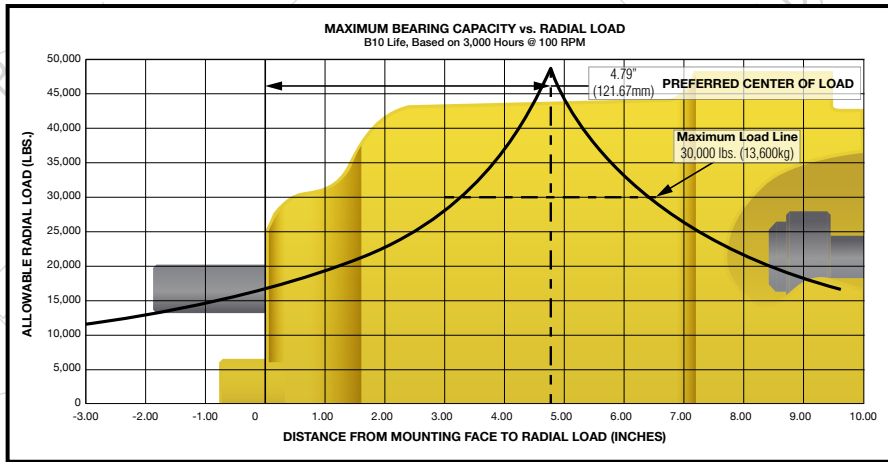

**NOTE:** These curves are supplied as a design guide and apply to resultant radial load only. They indicate the importance of maintaining wheel position over the bearing center. For actual analysis, applications should be reviewed by Auburn Gear Engineering using data supplied on Application Data Form.



1800-OILSOL  
1800-645765

<https://oilsolutions.com.au/>

sales@oilsolutions.com.au

# Power Wheel®

## Model 9 and Model 145 Spindle Output w/ Air Brake System

Providing Technology, Quality & Customer Support Around the Globe



ISO 9001-2008 Certified



OIL SOLUTIONS

1800-OILSOL  
1800-645765

<https://oilsolutions.com.au/>

[sales@oilsolutions.com.au](mailto:sales@oilsolutions.com.au)

**AuburnGear**  
Engineered Drive Solutions

phone 260.925.3200  
fax 260.925.4725  
web AuburnGear.com

Auburn Gear LLC  
400 East Auburn Drive  
Auburn, IN (USA) 46706-3499

M9SCAM0914