

# ML3

Self-Cooled Linear Motors

**Operating Instructions**  
**R911389762**

Edition 04

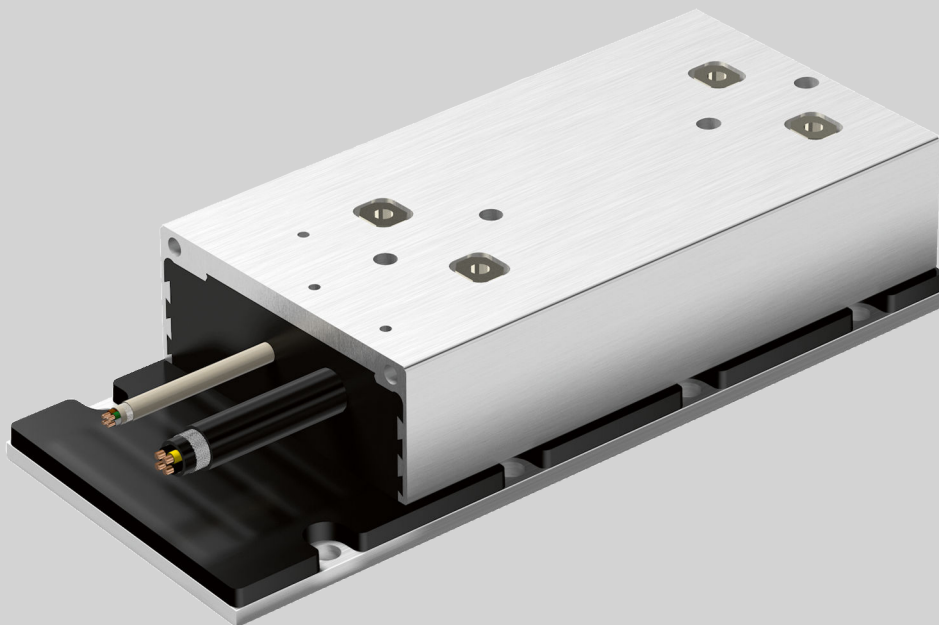

<b>Title</b>	ML3 Self-Cooled Linear Motors
<b>Type of Documentation</b>	Operating Instructions
<b>Document Typecode</b>	DOK-MOTOR*-ML3*****-IT04-EN-P
<b>Internal File Reference</b>	RS-050501693d7f1283c0a802867586f807-4-en-US-3
<b>Purpose of Documentation</b>	This documentation ... <ul style="list-style-type: none"> <li>• instructs assembly, operating and maintenance personnel</li> <li>• contains basic notes about assembly, operation and maintenance of the motors of type</li> </ul>
<b>Record of revisions</b>	Edition 04, 2021-10 See <a href="#">tab. 1-1 "Record of revisions" on page 1.</a>
<b>Copyright</b>	© Bosch Rexroth AG 2021 All rights reserved, also regarding any disposal, exploitation, reproduction, editing, distribution, as well as in the event of applications for industrial property rights.
<b>Liability</b>	The specified data is intended for product description purposes only and shall not be deemed to be a guaranteed characteristic unless expressly stipulated in the contract. All rights are reserved with respect to the content of this documentation and the availability of the product.
<b>Note</b>	This document has been printed on chlorine-free bleached paper.

<b>D</b> Deutsch	<b>USA</b> English	<b>F</b> Français
<p><b>▲WARNING</b> Lebensgefahr bei Nichtbeachtung der nachstehenden Sicherheitshinweise!</p> <p>Nehmen Sie die Produkte erst dann in Betrieb, nachdem Sie die mit dem Produkt gelieferten Unterlagen und Sicherheitshinweise vollständig durchgelesen, verstanden und beachtet haben.</p> <p>Sollten Ihnen keine Unterlagen in Ihrer Landessprache vorliegen, wenden Sie sich an Ihren zuständigen Rexroth-Vertriebspartner.</p> <p>Nur qualifiziertes Personal darf an Antriebskomponenten arbeiten.</p> <p>Nähere Erläuterungen zu den Sicherheitshinweisen entnehmen Sie Kapitel 1 dieser Dokumentation.</p>	<p><b>▲WARNING</b> Danger to life in case of non-compliance with the below-mentioned safety instructions!</p> <p>Do not attempt to install or put these products into operation until you have completely read, understood and observed the documents supplied with the product.</p> <p>If no documents in your language were supplied, please consult your Rexroth sales partner.</p> <p>Only qualified persons may work with drive components.</p> <p>For detailed explanations on the safety instructions, see chapter 1 of this documentation.</p>	<p><b>▲AVERTISSEMENT</b> Danger de mort en cas de non-respect des consignes de sécurité figurant ci-après !</p> <p>Ne mettez les produits en service qu'après avoir lu complètement et après avoir compris et respecté les documents et les consignes de sécurité fournis avec le produit.</p> <p>Si vous ne disposez pas de la documentation dans votre langue, merci de consulter votre partenaire Rexroth.</p> <p>Seul un personnel qualifié est autorisé à travailler sur les composants d'entraînement.</p> <p>Vous trouverez des explications plus détaillées relatives aux consignes de sécurité au chapitre 1 de la présente documentation.</p>
<p><b>▲WARNING</b> Hohe elektrische Spannung! Lebensgefahr durch elektrischen Schlag!</p> <p>Betreiben Sie Antriebskomponenten nur mit fest installiertem Schutzleiter.</p> <p>Schalten Sie vor Zugriff auf Antriebskomponenten die Spannungsversorgung aus.</p> <p>Beachten Sie die Entladezeiten von Kondensatoren.</p>	<p><b>▲WARNING</b> High electrical voltage! Danger to life by electric shock!</p> <p>Only operate drive components with a permanently installed equipment grounding conductor.</p> <p>Disconnect the power supply before accessing drive components.</p> <p>Observe the discharge times of the capacitors.</p>	<p><b>▲AVERTISSEMENT</b> Tensions électriques élevées ! Danger de mort par électrocution !</p> <p>N'exploitez les composants d'entraînement que si un conducteur de protection est installé de manière permanente.</p> <p>Avant d'intervenir sur les composants d'entraînement, coupez toujours la tension d'alimentation.</p> <p>Tenez compte des délais de décharge de condensateurs.</p>
<p><b>▲WARNING</b> Gefahrbringende Bewegungen! Lebensgefahr!</p> <p>Halten Sie sich nicht im Bewegungsbereich von Maschinen und Maschinenteilen auf.</p> <p>Verhindern Sie den unbeabsichtigten Zutritt für Personen.</p> <p>Bringen Sie vor dem Zugriff oder Zutritt in den Gefahrenbereich die Antriebe sicher zum Stillstand.</p>	<p><b>▲WARNING</b> Dangerous movements! Danger to life!</p> <p>Keep free and clear of the ranges of motion of machines and moving machine parts.</p> <p>Prevent personnel from accidentally entering the range of motion of machines.</p> <p>Make sure that the drives are brought to safe standstill before accessing or entering the danger zone.</p>	<p><b>▲AVERTISSEMENT</b> Mouvements entraînant une situation dangereuse ! Danger de mort !</p> <p>Ne séjournez pas dans la zone de mouvement de machines et de composants de machines.</p> <p>Évitez tout accès accidentel de personnes.</p> <p>Avant toute intervention ou tout accès dans la zone de danger, assurez-vous de l'arrêt préalable de tous les entraînements.</p>
<p><b>▲WARNING</b> Elektromagnetische / magnetische Felder! Gesundheitsgefahr für Personen mit Herzschrittmachern, metallischen Implantaten oder Hörgeräten!</p> <p>Zutritt zu Bereichen, in denen Antriebskomponenten montiert und betrieben werden, ist für oben genannten Personen untersagt bzw. nur nach Rücksprache mit einem Arzt erlaubt.</p>	<p><b>▲WARNING</b> Electromagnetic / magnetic fields! Health hazard for persons with heart pacemakers, metal implants or hearing aids!</p> <p>The above-mentioned persons are not allowed to enter areas in which drive components are mounted and operated, or rather are only allowed to do this after they consulted a doctor.</p>	<p><b>▲AVERTISSEMENT</b> Champs électromagnétiques / magnétiques ! Risque pour la santé des porteurs de stimulateurs cardiaques, d'implants métalliques et d'appareils auditifs !</p> <p>L'accès aux zones où sont montés et exploités les composants d'entraînement est interdit aux personnes susmentionnées ou bien ne leur est autorisé qu'après consultation d'un médecin.</p>
<p><b>▲VORSICHT</b> Heiße Oberflächen (&gt; 60 °C)! Verbrennungsgefahr!</p> <p>Vermeiden Sie das Berühren von metallischen Oberflächen (z. B. Kühlkörpern). Abkühlzeit der Antriebskomponenten einhalten (mind. 15 Minuten).</p>	<p><b>▲CAUTION</b> Hot surfaces (&gt; 60 °C [140 °F])! Risk of burns!</p> <p>Do not touch metallic surfaces (e.g. heat sinks). Comply with the time required for the drive components to cool down (at least 15 minutes).</p>	<p><b>▲ATTENTION</b> Surfaces chaudes (&gt; 60 °C)! Risque de brûlure !</p> <p>Évitez de toucher des surfaces métalliques (p. ex. dissipateurs thermiques). Respectez le délai de refroidissement des composants d'entraînement (au moins 15 minutes).</p>

D Deutsch	USA English	F Français
<p><b>⚠ VORSICHT</b> Unsachgemäße Handhabung bei Transport und Montage! Verletzungsgefahr!</p> <p>Verwenden Sie geeignete Montage- und Transporteinrichtungen.</p> <p>Benutzen Sie geeignetes Werkzeug und persönliche Schutzausrüstung.</p>	<p><b>⚠ CAUTION</b> Improper handling during transport and mounting! Risk of injury!</p> <p>Use suitable equipment for mounting and transport.</p> <p>Use suitable tools and personal protective equipment.</p>	<p><b>⚠ ATTENTION</b> Manipulation incorrecte lors du transport et du montage ! Risque de blessure !</p> <p>Utilisez des dispositifs de montage et de transport adéquats.</p> <p>Utilisez des outils appropriés et votre équipement de protection personnel.</p>
<p><b>⚠ VORSICHT</b> Unsachgemäße Handhabung von Batterien! Verletzungsgefahr!</p> <p>Versuchen Sie nicht, leere Batterien zu reaktivieren oder aufzuladen (Explosions- und Verätzungsgefahr).</p> <p>Zerlegen oder beschädigen Sie keine Batterien. Werfen Sie Batterien nicht ins Feuer.</p>	<p><b>⚠ CAUTION</b> Improper handling of batteries! Risk of injury!</p> <p>Do not attempt to reactivate or recharge low batteries (risk of explosion and chemical burns).</p> <p>Do not dismantle or damage batteries. Do not throw batteries into open flames.</p>	<p><b>⚠ ATTENTION</b> Manipulation incorrecte de piles! Risque de blessure!</p> <p>N'essayez pas de réactiver des piles vides ou de les charger (risque d'explosion et de brûlure par acide).</p> <p>Ne désassemblez et n'endommagez pas les piles. Ne jetez pas des piles dans le feu.</p>



E Español	P Português	I Italiano
<p><b>⚠ ADVERTENCIA</b> ¡Peligro de muerte en caso de no observar las siguientes indicaciones de seguridad!</p> <p>Los productos no se pueden poner en servicio hasta después de haber leído por completo, comprendido y tenido en cuenta la documentación y las advertencias de seguridad que se incluyen en la entrega.</p> <p>Si no dispusiera de documentación en el idioma de su país, diríjase a su distribuidor competente de Rexroth.</p> <p>Solo el personal debidamente cualificado puede trabajar en componentes de accionamiento.</p> <p>Encontrará más detalles sobre las indicaciones de seguridad en el capítulo 1 de esta documentación.</p>	<p><b>⚠ ATENÇÃO</b> Perigo de vida em caso de inobservância das seguintes instruções de segurança!</p> <p>Utilize apenas os produtos depois de ter lido, compreendido e tomado em consideração a documentação e as instruções de segurança fornecidas juntamente com o produto.</p> <p>Se não tiver disponível a documentação na sua língua, dirija-se ao seu parceiro de venda responsável da Rexroth.</p> <p>Apenas pessoal qualificado pode trabalhar nos componentes de acionamento.</p> <p>Explicações mais detalhadas relativamente às instruções de segurança constam no capítulo 1 desta documentação.</p>	<p><b>⚠ AVVERTENZA</b> Pericolo di morte in caso di inosservanza delle seguenti indicazioni di sicurezza!</p> <p>Mettere in funzione i prodotti solo dopo aver letto, compreso e osservato per intero la documentazione e le indicazioni di sicurezza fornite con il prodotto.</p> <p>Se non dovesse essere presente la documentazione nella vostra lingua, siete pregati di rivolgervi al rivenditore Rexroth competente.</p> <p>Solo personale qualificato può eseguire lavori sui componenti di comando.</p> <p>Per ulteriori spiegazioni riguardanti le indicazioni di sicurezza consultare il capitolo 1 di questa documentazione.</p>
<p><b>⚠ ADVERTENCIA</b> ¡Alta tensión eléctrica! ¡Peligro de muerte por descarga eléctrica!</p> <p>Active sólo los componentes de accionamiento con el conductor protector firmemente instalado.</p> <p>Desconecte la alimentación eléctrica antes de manipular los componentes de accionamiento.</p> <p>Tenga en cuenta los tiempos de descarga de los condensadores.</p>	<p><b>⚠ ATENÇÃO</b> Alta tensão elétrica! Perigo de vida devido a choque elétrico!</p> <p>Opere componentes de acionamento apenas com condutores de proteção instalados.</p> <p>Desligue a alimentação de tensão antes de aceder aos componentes de acionamento.</p> <p>Respeite os períodos de descarga dos condensadores.</p>	<p><b>⚠ AVVERTENZA</b> Alta tensione elettrica! Pericolo di morte in seguito a scosse elettriche!</p> <p>Mettere in esercizio i componenti di comando solo con conduttore di messa a terra ben installato.</p> <p>Staccare l'alimentazione prima di intervenire sui componenti di comando.</p> <p>Osservare i tempi di scarica del condensatore.</p>
<p><b>⚠ ADVERTENCIA</b> ¡Movimientos peligrosos! ¡Peligro de muerte!</p> <p>No permanezca en la zona de movimiento de las máquinas ni de sus piezas.</p> <p>Impida el acceso accidental de personas.</p> <p>Antes de acceder o introducir las manos en la zona de peligro, los accionamientos se tienen que haber parado con seguridad.</p>	<p><b>⚠ ATENÇÃO</b> Movimentos perigosos! Perigo de vida!</p> <p>Não permaneça na área de movimentação das máquinas e das peças das máquinas.</p> <p>Evite o acesso involuntário para pessoas.</p> <p>Antes de entrar ou aceder à área perigosa, imobilize os acionamentos de forma segura.</p>	<p><b>⚠ AVVERTENZA</b> Movimenti pericolosi! Pericolo di morte!</p> <p>Non sostare nelle zone di manovra delle macchine e delle loro parti.</p> <p>Impedire un accesso non autorizzato per le persone.</p> <p>Prima di accedere alla zona di pericolo, arrestare e bloccare gli azionamenti.</p>



<b>E</b> Español	<b>P</b> Português	<b>I</b> Italiano
<p><b>⚠ ADVERTENCIA</b> ¡Campos electromagnéticos/magnéticos! ¡Peligro para la salud de las personas con marcapasos, implantes metálicos o audífonos!</p> <p>El acceso de las personas arriba mencionadas a las zonas de montaje o funcionamiento de los componentes de accionamiento está prohibido, salvo que lo autorice previamente un médico.</p>	<p><b>⚠ ATENÇÃO</b> Campos eletromagnéticos / magnéticos! Perigo de saúde para pessoas com marcapassos, implantes metálicos ou aparelhos auditivos!</p> <p>Acesso às áreas, nas quais os componentes de acionamento são montados e operados, é proibido para as pessoas em cima mencionadas ou apenas após permissão de um médico.</p>	<p><b>⚠ AVVERTENZA</b> Campi elettromagnetici / magnetici! Pericolo per la salute delle persone portatrici di pacemaker, protesi metalliche o apparecchi acustici!</p> <p>L'accesso alle zone in cui sono installati o in funzione componenti di comando è vietato per le persone sopra citate o consentito solo dopo un colloquio con il medico.</p>
<p><b>⚠ ATENCIÓN</b> ¡Superficies calientes (&gt; 60 °C)! ¡Peligro de quemaduras!</p> <p>Evite el contacto con las superficies calientes (p. ej., disipadores de calor). Observe el tiempo de enfriamiento de los componentes de accionamiento (mín. 15 minutos).</p>	<p><b>⚠ CUIDADO</b> Superfícies quentes (&gt; 60 °C)! Perigo de queimaduras!</p> <p>Evite tocar superfícies metálicas (p. ex. radiadores). Respeite o tempo de arrefecimento dos componentes de acionamento (mín. 15 minutos).</p>	<p><b>⚠ ATTENZIONE</b> Superfici bollenti (&gt; 60 °C)! Pericolo di ustioni!</p> <p>Evitare il contatto con superfici metalliche (ad es. dissipatori di calore). Rispettare i tempi di raffreddamento dei componenti di comando (almeno 15 minuti).</p>
<p><b>⚠ ATENCIÓN</b> ¡Manipulación inadecuada en el transporte y montaje! ¡Peligro de lesiones!</p> <p>Utilice dispositivos de montaje y de transporte adecuados.</p> <p>Utilice herramientas adecuadas y equipo de protección personal.</p>	<p><b>⚠ CUIDADO</b> Manejo incorreto no transporte e montagem! Perigo de ferimentos!</p> <p>Utilize dispositivos de montagem e de transporte adequados.</p> <p>Utilize ferramentas e equipamento de proteção individual adequados.</p>	<p><b>⚠ ATTENZIONE</b> Manipolazione inappropriata durante il trasporto e il montaggio! Pericolo di lesioni!</p> <p>Utilizzare dispositivi di montaggio e trasporto adatti.</p> <p>Utilizzare attrezzi adatti ed equipaggiamento di protezione personale.</p>
<p><b>⚠ ATENCIÓN</b> ¡Manejo inadecuado de las pilas! ¡Peligro de lesiones!</p> <p>No trate de reactivar o cargar pilas descargadas (peligro de explosión y cauterización).</p> <p>No desarme ni dañe las pilas. No tire las pilas al fuego.</p>	<p><b>⚠ CUIDADO</b> Manejo incorreto de baterias! Perigo de ferimentos!</p> <p>Não tente reativar nem carregar baterias vazias (perigo de explosão e de queimaduras com ácido).</p> <p>Não desmonte nem danifique as baterias. Não deite as baterias no fogo.</p>	<p><b>⚠ ATTENZIONE</b> Utilizzo inappropriato delle batterie! Pericolo di lesioni!</p> <p>Non tentare di riattivare o ricaricare batterie scariche (pericolo di esplosione e corrosione).</p> <p>Non scorporare o danneggiare le batterie. Non gettare le batterie nel fuoco.</p>

<b>S</b> Svenska	<b>DK</b> Dansk	<b>NL</b> Nederlands
<p><b>⚠ VARNING</b> Livsfara om följande säkerhetsanvisningar inte följs!</p> <p>Använd inte produkterna innan du har läst och förstått den dokumentation och de säkerhetsanvisningar som medföljer produkten, och följ alla anvisningar.</p> <p>Kontakta din Rexroth-återförsäljare om dokumentationen inte medföljer på ditt språk.</p> <p>Endast kvalificerad personal får arbeta med drivkomponenterna.</p> <p>Se kapitel 1 i denna dokumentation för närmare beskrivningar av säkerhetsanvisningarna.</p>	<p><b>⚠ ADVARSEL</b> Livsfare ved manglende overholdelse af nedenstående sikkerhedsanvisninger!</p> <p>Tag ikke produktet i brug, før du har læst og forstået den dokumentation og de sikkerhedsanvisninger, som følger med produktet, og overhold de givne anvisninger.</p> <p>Kontakt din Rexroth-forhandler, hvis dokumentationen ikke medfølger på dit sprog.</p> <p>Det er kun kvalificeret personale, der må arbejde på drive components.</p> <p>Nærmere forklaringer til sikkerhedsanvisningerne fremgår af kapitel 1 i denne dokumentation!</p>	<p><b>⚠ WAARSCHUWING</b> Levensgevaar bij niet-naleving van onderstaande veiligheidsinstructies!</p> <p>Stel de producten pas in bedrijf nadat u de met het product geleverde documenten en de veiligheidsinformatie volledig gelezen, begrepen en in acht genomen heeft.</p> <p>Mocht u niet beschikken over documenten in uw landstaal, kunt u contact opnemen met uw plaatselijke Rexroth distributiepartner.</p> <p>Uitsluitend gekwalificeerd personeel mag aan de aandrijvingscomponenten werken.</p> <p>Meer informatie over de veiligheidsinstructies vindt u in hoofdstuk 1 van deze documentatie.</p>
<p><b>⚠ VARNING</b> Hög elektrisk spänning! Livsfara genom elchock!</p> <p>Använd endast drivkomponenterna med fastmonterad skyddsledare.</p> <p>Koppla bort spänningsförsörjningen före arbete på drivkomponenter.</p> <p>Var medveten om kondensatorernas urladdningstid.</p>	<p><b>⚠ ADVARSEL</b> Elektrisk højspænding! Livsfare på grund af elektrisk stød!</p> <p>Drive components må kun benyttes med et fast installeret jordstik.</p> <p>Sørg for at koble spændingsforsyningen fra, inden du rører ved drive components.</p> <p>Overhold kondensatorernes afladningstider.</p>	<p><b>⚠ WAARSCHUWING</b> Hoge elektrische spanning! Levensgevaar door elektrische schok!</p> <p>Bedien de aandrijvingscomponenten uitsluitend met vast geïnstalleerde aardleiding.</p> <p>Schakel voor toegang tot aandrijvingscomponenten de spanningsvoorziening uit.</p> <p>Neem de ontlaadtijden van condensatoren in acht.</p>

S Svenska	DK Dansk	NL Nederlands
<p><b>⚠ VARNING</b> Farliga rörelser! Livsfaral</p> <p>Uppehåll dig inte inom maskiners och maskindelarers rörelseområde.</p> <p>Förhindra att obehöriga personer får tillträde.</p> <p>Innan du börjar arbeta eller vistas inom drivsystemets riskområde måste maskinen vara stillastående.</p>	<p><b>⚠ ADVARSEL</b> Farlige bevægelser! Livsfare!</p> <p>Du må ikke opholde dig inden for maskiners og maskindeles bevægelsesradius.</p> <p>Sørg for, at ingen personer kan få utilsigtet adgang.</p> <p>Stands drevene helt, inden du rører ved drevene eller træder ind i deres fareområde.</p>	<p><b>⚠ WAARSCHUWING</b> Risicovolle bewegingen! Levensgevaar!</p> <p>Houdt u niet op in het bewegingsbereik van machines en machineonderdelen.</p> <p>Voorkom dat personen onbedoeld toegang verkrijgen.</p> <p>Voor toegang tot de gevaarlijke zone moeten de aandrijvingen veilig tot stilstand gebracht zijn.</p>
<p><b>⚠ VARNING</b> Elektromagnetiska/magnetiska fält! Hälsofara för personer med pacemaker, implantat av metall eller hörapparat!</p> <p>Det är förbjudet för ovan nämnda personer (eller kräver överläggning med läkare) att beträda områden där drivkomponenter är monterade och i drift.</p>	<p><b>⚠ ADVARSEL</b> Elektromagnetiske/magnetiske felter! Sundhedsfare for personer med pacemakere, metalliske implantater eller høreapparater!</p> <p>For disse personer er der adgang forbudt eller kun adgang med tilladelse fra læge til de områder, hvor drive components monteres og drives.</p>	<p><b>⚠ WAARSCHUWING</b> Elektromagnetische / magnetische velden! Gevaar voor de gezondheid van personen met pacemakers, metalen implantaten of hoorapparaten!</p> <p>Toegang tot gebieden, waarin aandrijvingscomponenten worden gemonteerd en bediend, is verboden voor voornoemde personen of uitsluitend toegestaan na overleg met een arts.</p>
<p><b>⚠ OBSERVERA</b> Varma ytor (&gt; 60 °C)! Risk för brännskador!</p> <p>Undvik att vidröra metallytor (t.ex. kylelement). Var medveten om att det tar tid för drivkomponenterna att svalna (minst 15 minuter).</p>	<p><b>⚠ FORSIGTIG</b> Varme overflader (&gt; 60 °C)! Risiko for forbrændinger!</p> <p>Undgå at berøre metaloverflader (f.eks. køleelementer). Overhold drive components nedkølingstid (min. 15 min.).</p>	<p><b>⚠ VOORZICHTIG</b> Hete oppervlakken (&gt; 60 °C)! Verbrandingsgevaar!</p> <p>Voorkom contact met metalen oppervlakken (bijv. Koellichamen). Afkoeltijd van de aandrijvingscomponenten in acht nemen (min. 15 minuten).</p>
<p><b>⚠ OBSERVERA</b> Felaktig hantering vid transport och montering! Skaderisk!</p> <p>Använd passande monterings- och transportanordningar.</p> <p>Använd lämpliga verktyg och personlig skyddsutrustning.</p>	<p><b>⚠ FORSIGTIG</b> Fejlhåndtering ved transport og montering! Risiko for kvæstelser!</p> <p>Benyt egnede monterings- og transportanordninger.</p> <p>Benyt egnet værktøj og personligt sikkerhedsudstyr.</p>	<p><b>⚠ VOORZICHTIG</b> Onjuist gebruik bij transport en montage! Letselgevaar!</p> <p>Gebruik geschikte montage- en transportinrichtingen.</p> <p>Gebruik geschikt gereedschap en een persoonlijke veiligheidsuitrusting.</p>
<p><b>⚠ OBSERVERA</b> Felaktig hantering av batterier! Skaderisk!</p> <p>Försök inte återaktivera eller ladda upp batterier (risk för explosioner och frätskador).</p> <p>Batterierna får inte tas isär eller skadas. Släng inte batterierna i elden.</p>	<p><b>⚠ FORSIGTIG</b> Fejlhåndtering af batterier! Risiko for kvæstelser!</p> <p>Forsøg ikke at genaktivere eller oplade tomme batterier (eksplosions- og ætsningsfare).</p> <p>Undlad at skille batterier ad eller at beskadige dem. Smid ikke batterier ind i åben ild.</p>	<p><b>⚠ VOORZICHTIG</b> Onjuist gebruik van batterijen! Letselgevaar!</p> <p>Probeer nooit lege batterijen te reactiveren of op te laden (explosiegevaar en gevaar voor beschadiging van weefsel door cauterisatie).</p> <p>Batterijen niet demonteren of beschadigen. Nooit batterijen in het vuur werpen.</p>

 Suomi	 Polski	 Český
<p><b>VAROITUS</b> Näiden turvaohjeiden noudattamatta jättämisestä on seurauksena hengenvaara!</p> <p>Ota tuote käyttöön vasta sen jälkeen, kun olet lukenut läpi tuotteen mukana toimitetut asiakirjat ja turvallisuusohjeet, ymmärtänyt ne ja ottanut ne huomioon.</p> <p>Jos asiakirjoja ei ole saatavana omalla äidinkielelläsi, ota yhteys asianomaiseen Rexrothin myyntiedustajaan.</p> <p>Käyttölaitteiden komponenttien parissa saa työskennellä ainoastaan valtuutettu henkilöstö.</p> <p>Lisätietoa turvaohjeista löydät tämän dokumentaation luvusta 1.</p>	<p><b>OSTRZEŻENIE</b> Zagrożenie życia w razie nieprzestrzegania poniższych wskazówek bezpieczeństwa!</p> <p>Nie uruchamiać produktów przed uprzednim przeczytaniem i pełnym zrozumieniem wszystkich dokumentów dostarczonych wraz z produktem oraz wskazówek bezpieczeństwa. Należy przestrzegać wszystkich zawartych tam zaleceń.</p> <p>W przypadku braku dokumentów w Państwa języku, prosimy o skontaktowanie się z lokalnym partnerem handlowym Rexroth.</p> <p>Przy zespołach napędowych może pracować wyłącznie wykwalifikowany personel.</p> <p>Blizsze objaśnienia wskazówek bezpieczeństwa znajdują się w Rozdziale 1 niniejszej dokumentacji.</p>	<p><b>VAROVÁNÍ</b> Nebezpečí života v případě nedodržení níže uvedených bezpečnostních pokynů!</p> <p>Před uvedením výrobků do provozu si přečtěte kompletní dokumentaci a bezpečnostní pokyny dodávané s výrobkem, pochopte je a dodržujte.</p> <p>Nemáte-li k dispozici podklady ve svém jazyce, obraťte se na příslušného obchodního partnera Rexroth.</p> <p>Na komponentách pohonu smí pracovat pouze kvalifikovaný personál.</p> <p>Podrobnější vysvětlení k bezpečnostním pokynům naleznete v kapitole 1 této dokumentace.</p>
<p><b>VAROITUS</b> Voimakas sähköjännite! Sähköiskun aiheuttama hengenvaara!</p> <p>Käytä käyttölaitteen komponentteja ainoastaan maadoitusjohtimen ollessa kiinteästi asennettuna.</p> <p>Katkaise jännitteensyöttö ennen käyttölaitteen komponenteille suoritettavien töiden aloittamista.</p> <p>Huomioi kondensaattoreiden purkausajat.</p>	<p><b>OSTRZEŻENIE</b> Wysokie napięcie elektryczne! Zagrożenie życia w wyniku porażenia prądem!</p> <p>Zespoły napędu mogą być eksploatowane wyłącznie z zainstalowanym na stałe przewodem ochronnym.</p> <p>Przed uzyskaniem dostępu do podzespołów napędu należy odłączyć zasilanie elektryczne.</p> <p>Zwracać uwagę na czas rozładowania kondensatorów.</p>	<p><b>VAROVÁNÍ</b> Vysoké elektrické napětí! Nebezpečí života při zasažení elektrickým proudem!</p> <p>Komponenty pohonu smí být v provozu pouze s pevně nainstalovaným ochranným vodičem.</p> <p>Než začnete zasahovat do komponent pohonu, odpojte je od elektrického napájení.</p> <p>Dodržujte vybíjecí časy kondenzátorů.</p>
<p><b>VAROITUS</b> Vaarallisia liikkeitä! Hengenvaara!</p> <p>Älä oleskele koneiden tai koneenosien liikealueella.</p> <p>Pidä huolta siitä, ettei muita henkilöitä pääse alueelle vahingossa.</p> <p>Pysäytä käyttölaitteet varmasti ennen vaara-alueelle koskemista tai menemistä.</p>	<p><b>OSTRZEŻENIE</b> Niebezpieczne ruchy! Zagrożenie życia!</p> <p>Nie wolno przebywać w obszarze pracy maszyny i jej elementów.</p> <p>Nie dopuszczać osób niepowołanych do obszaru pracy maszyny.</p> <p>Przed dotknięciem urządzenia/maszyny lub zbliżeniem się do obszaru zagrożenia należy zgodnie z zasadami bezpieczeństwa wyłączyć napędy.</p>	<p><b>VAROVÁNÍ</b> Nebezpečné pohyby! Nebezpečí života!</p> <p>Nezdržujte se v dosahu pohybu strojů a jejich součástí.</p> <p>Zabraňte náhodnému přístupu osob.</p> <p>Před zásahem nebo vstupem do nebezpečného prostoru bezpečně zastavte pohonu.</p>
<p><b>VAROITUS</b> Sähkömagneettisia/ magneettisia kenttiä! Terveystieteellisten haittojen vaara henkilöille, joilla on sydämentahdistin, metallinen implantti tai kuulolaite!</p> <p>Yllä mainituilta henkilöiltä on pääsy kielletty alueelle, joilla asennetaan tai käytetään käyttölaitteen komponentteja, tai heidän on ensin saatava tähän suostumus lääkäriltään.</p>	<p><b>OSTRZEŻENIE</b> Pola elektromagnetyczne / magnetyczne! Zagrożenie zdrowia dla osób z rozrusznikiem serca, metalowymi implantami lub aparatami słuchowymi!</p> <p>Wstęp na teren, gdzie odbywa się montaż i eksploatacja napędów jest dla ww. osób zabroniony względnie dozwolony po konsultacji z lekarzem.</p>	<p><b>VAROVÁNÍ</b> Elektromagnetická/ magnetická pole! Nebezpečí pro zdraví osob s kardiostimulátory, kovovými implantáty nebo naslouchadly!</p> <p>Výše uvedené osoby mají zakázán přístup do prostorů, kde jsou montovány a používány komponenty pohonu, resp. ho mají povolen pouze po poradě s lékařem.</p>
<p><b>HUOMIO</b> Kuumia pintoja (&gt; 60 °C)! Palovammojen vaara!</p> <p>Vältä metallipintojen koskettamista (esim. jäähdytyslevyt). Noudata käyttölaitteen komponenttien jäähtymisaikoja (väh. 15 minuuttia).</p>	<p><b>PRZESTROGA</b> Gorące powierzchnie (&gt; 60 °C)! Niebezpieczeństwo poparzenia!</p> <p>Unikać kontaktu z powierzchniami metalowymi (np. radiatorami). Przestrzegać czasów schładzania podzespołów napędów (min. 15 minut).</p>	<p><b>UPOZORNĚNÍ</b> Horké povrchy (&gt; 60 °C)! Nebezpečí popálení!</p> <p>Nedotýkejte se kovových povrchů (např. chladičích těles). Dodržujte dobu ochlazení komponent pohonu (min. 15 minut).</p>

 Suomi	 Polski	 Český
<p><b>▲ HUOMIO</b> Epäasianmukainen käsittely kuljetuksen ja asennuksen yhteydessä! Loukkaantumisaara!</p> <p>Käytä soveltuvia asennus- ja kuljetuslaitteita.</p> <p>Käytä omia työkaluja ja henkilökohtaisia suojavarusteita.</p>	<p><b>▲ PRZESTROGA</b> Niewłaściwe obchodzenie się podczas transportu i montażu! Ryzyko urazu!</p> <p>Stosować odpowiednie urządzenia montażowe i transportowe.</p> <p>Stosować odpowiednie narzędzia i środki ochrony osobistej.</p>	<p><b>▲ UPOZORNĚNÍ</b> Nesprávné zacházení při přepravě a montáži! Nebezpečí zranění!</p> <p>Používejte vhodná montážní a dopravní zařízení.</p> <p>Používejte vhodné nářadí a osobní ochranné vybavení.</p>
<p><b>▲ HUOMIO</b> Paristojen epäasianmukainen käsittely! Loukkaantumisaara!</p> <p>Älä yritä saada tyhjiä paristoja toimimaan tai ladata niitä uudelleen (räjähdys- ja syöpymisaara).</p> <p>Älä hajota paristoja osiin tai vaurioita niitä. Älä heitä paristoja tullen.</p>	<p><b>▲ PRZESTROGA</b> Niewłaściwe obchodzenie się z bateriami! Ryzyko urazu!</p> <p>Nie próbować reaktywować i nie ładować zużytych baterii (niebezpieczeństwo wybuchu oraz poparzenia żrącą substancją).</p> <p>Nie demontować i nie niszczyć baterii. Nie wrzucać baterii do ognia.</p>	<p><b>▲ UPOZORNĚNÍ</b> Nesprávné zacházení s bateriemi! Nebezpečí zranění!</p> <p>Nepokoušejte se znovu aktivovat nebo dobíjet prázdné baterie (nebezpečí výbuchu a poleptání).</p> <p>Nerozebírejte ani nepoškožujte baterie. Neházejte baterie do ohně.</p>

 Slovensko	 Slovenčina	 Română
<p><b>▲ OPOZORILO</b> Življenjska nevarnost pri neupoštevanju naslednjih napotkov za varnost!</p> <p>Izdelke začnite uporabljati šele, ko v celoti preberete, razumete in upošteвате izdelkom priloženo dokumentacijo in varnostne napotke.</p> <p>Če priložena dokumentacija ni na voljo v vašem maternem jeziku, se obrnite na pristojnega distributerja Rexroth.</p> <p>Samo kvalificirano osebje sme delati na pogonskih komponentah.</p> <p>Podrobnejša pojasnila o varnostnih navodilih najdete v poglavju 1 v tej dokumentaciji.</p>	<p><b>▲ VAROVANIE</b> Nebezpečnostv ohrozenia života pri nedodržiavaní nasledujúcich bezpečnostných pokynov!</p> <p>Výrobky uvádzajte do prevádzky až potom, čo ste úplne prečítali, pochopili a zobrali do úvahy podklady a bezpečnostné pokyny dodané s výrobkom.</p> <p>Ak by ste nemali k dispozícii žiadne podklady v jazyku svojej krajiny, obráťte sa prosím na svojho príslušného predajcu Rexroth.</p> <p>Na komponentoch pohonu smie pracovať iba kvalifikovaný personál.</p> <p>Bližšie vysvetlenia k bezpečnostným pokynom zistíte z kapitoly 1 tejto dokumentácie.</p>	<p><b>▲ AVERTIZARE</b> Pericol de moarte în cazul nerespectării următoarelor instrucțiuni de siguranță!</p> <p>Punerea în funcțiune a produselor trebuie efectuată după citirea, înțelegerea și respectarea documentelor și instrucțiunilor de siguranță, care sunt livrate împreună cu produsele.</p> <p>În cazul în care documentele nu sunt în limba dumneavoastră maternă, vă rugăm să contactați partenerul de vânzări Rexroth.</p> <p>Numai un personal calificat poate lucra cu componentele de acționare.</p> <p>Explicații detaliate privind instrucțiunile de siguranță găsiți în capitolul 1 al acestei documentații.</p>
<p><b>▲ OPOZORILO</b> Visoka električna napetost! Življenjska nevarnost zaradi električnega udara!</p> <p>Pogonske komponente uporabljajte samo s fiksno nameščenim zaščitnim vodnikom.</p> <p>Pred dostopom do pogonske komponente odklopite napajanje.</p> <p>Upošteвайте čase praznjenja kondenzatorjev.</p>	<p><b>▲ VAROVANIE</b> Vysoké elektrické napätie! Nebezpečnostv ohrozenia života v dôsledku zásahu elektrickým prúdom!</p> <p>Komponenty pohonu prevádzkujte iba s pevne nainštalovaným ochranným vodičom.</p> <p>Pred prístupom na komponenty pohonu odpojte zdroj napätia.</p> <p>Rešpektujte časy vybitia kondenzátorov.</p>	<p><b>▲ AVERTIZARE</b> Tensiune electrică înaltă! Pericol de moarte prin electrocutare!</p> <p>Exploatați componentele de acționare numai cu împământarea instalată permanent.</p> <p>Înainte de intervenția asupra componentelor de acționare, deconectați alimentarea cu tensiune electrică.</p> <p>Țineți cont de timpii de descărcare ai condensatorilor.</p>
<p><b>▲ OPOZORILO</b> Nevarni premiki! Življenjska nevarnost!</p> <p>Ne zadržujte se v območju delovanja strojev.</p> <p>Preprečite nenadzorovan dostop oseb.</p> <p>Pred prijemom ali dostopom v nevarno območje varno zaustavite vse gnane dele.</p>	<p><b>▲ VAROVANIE</b> Pohyby prinášajúce nebezpečnostv! Nebezpečnostv ohrozenia života!</p> <p>Nezdržiaвайте sa v oblasti pohybu strojov a častí strojov.</p> <p>Zabráňte nepovolanému prístupu osôb.</p> <p>Pred zásahom alebo prístupom do nebezpečnej oblasti uveďte pohony bezpečne do zastavenia.</p>	<p><b>▲ AVERTIZARE</b> Mișcări periculoase! Pericol de moarte!</p> <p>Nu staționați în zona de mișcare a mașinilor și a componentelor în mișcare a mașinilor.</p> <p>Împiedicați accesul neintenționat al persoanelor în zona de lucru a mașinilor.</p> <p>Înainte de intervenția sau accesul în zona periculoasă, opriți în siguranță componentele de acționare.</p>

SLO Slovensko	SK Slovenčina	RO Română
<p><b>⚠ OPOZORILO</b> Elektromagnetna / magnetna polja! Nevarnost za zdravje za osebe s spodbujevalniki srca, kovinskimi vsadki ali slušnimi aparati!</p> <p>Dostop do območij, v katerih so nameščene delujoče pogonske komponente, je za zgoraj navedene osebe prepovedan oz. dovoljen samo po posvetu z zdravnikom.</p>	<p><b>⚠ VAROVANIE</b> Elektromagnetické/ magnetické polia! Nebezpečenstvo pre zdravie osôb s kardioštimulátormi, kovovými implantátmi alebo načúvacími prístrojmi!</p> <p>Prístup k oblastiam, v ktorých sú namontované a prevádzkujú sa komponenty pohonu, je pre hore uvedené osoby zakázaný resp. je dovolený iba po konzultácii s lekárom.</p>	<p><b>⚠ AVERTIZARE</b> Câmpuri electromagnetice / magnetice! Pericol pentru sănătatea persoanelor cu stimuloare cardiace, implanturi metalice sau aparate auditive!</p> <p>Intrarea în zone, în care se montează sau se exploatează componente de acționare, este interzisă pentru persoanele sus numite respectiv este permisă numai cu acordul medicului.</p>
<p><b>⚠ POZOR</b> Vroče površine (&gt; 60 °C)! Nevarnost opeklin!</p> <p>Izogibajte se stiku s kovinskimi površinami (npr. hladilnimi telesii). Upoštevajte čas hlajenja pogonskih komponent (najm. 15 minut).</p>	<p><b>⚠ UPOZORNENIE</b> Horúce povrchy (&gt; 60 °C)! Nebezpečenstvo popálenia!</p> <p>Zabráňte kontaktu s kovovými povrchmi (napr. chladiacimi telesami). Dodržiavajte čas vychladenia komponentov pohonu (min. 15 minút).</p>	<p><b>⚠ ATENȚIE</b> Suprafețe fierbinți (&gt; 60 °C)! Pericol de arsuri!</p> <p>Nu atingeți suprafețele metalice (de ex. radiatoare de răcire). Respectați timpii de răcire ai componentelor de acționare (min. 15 minute).</p>
<p><b>⚠ POZOR</b> Nestrokovno ravnanje med transportom in nameštivijo! Nevarnost poškodb!</p> <p>Uporablajte ustrezne pripomočke za nameščanje in transport.</p> <p>Uporabite ustrezno orodje in osebno zaščitno opremo.</p>	<p><b>⚠ UPOZORNENIE</b> Neodborná manipulácia pri transporte a montáži! Nebezpečenstvo poranenia!</p> <p>Používajte vhodné montážne a transportné zariadenia.</p> <p>Používajte vhodné náradie a osobné ochranné prostriedky.</p>	<p><b>⚠ ATENȚIE</b> Manipulare necorespunzătoare la transport și montaj! Pericol de vătămare!</p> <p>Utilizați dispozitive adecvate de montaj și transport.</p> <p>Folosiți instrumente corespunzătoare și echipament personal de protecție.</p>
<p><b>⚠ POZOR</b> Nepravilno ravnanje z baterijami! Nevarnost poškodb!</p> <p>Ne poskušajte ponovno aktivirati ali napolniti praznih baterij (Nevarnost zaradi eksplozije ali jedkanja).</p> <p>Ne razstavljajte ali poškodujte nobenih baterij. Baterij ne mečite v ogenj.</p>	<p><b>⚠ UPOZORNENIE</b> Neodborná manipulácia s batériami! Nebezpečenstvo poranenia!</p> <p>Nepokúšajte sa reaktivovať alebo nabíjať prázdne batérie (nebezpečenstvo výbuchu a poleptania).</p> <p>Batérie nerozoberajte ani nepoškodzuje. Nehádzte batérie do ohňa.</p>	<p><b>⚠ ATENȚIE</b> Manipulare necorespunzătoare a bateriilor! Pericol de vătămare!</p> <p>Nu încercați să reactivați sau să încărcați bateriile goale (pericol de explozie și pericol de arsuri).</p> <p>Nu dezasamblați și nu deteriorați bateriile. Nu aruncați bateriile în foc.</p>

H Magyar	BG Български	LV Latviski
<p><b>⚠ FIGYELMEZTETÉS!</b> Az alábbi biztonsági útmutatások figyelmen kívül hagyása életveszélyes helyzethez vezethet!</p> <p>Üzembe helyezés előtt olvassa el, értelmezze, és vegye figyelembe a csomagban található dokumentumban foglaltakat és a biztonsági útmutatásokat.</p> <p>Amennyiben a csomagban nem talál az Ön nyelvén írt dokumentumokat, vegye fel a kapcsolatot az illetékes Rexroth-képviselővel.</p> <p>A hajtás alkatrészein kizárólag képzett személy dolgozhat.</p> <p>A biztonsági útmutatókkal kapcsolatban további magyarázatot ennek a dokumentumnak az első fejezetében találhat.</p>	<p><b>⚠ ПРЕДУПРЕЖДЕНИЕ</b> Опасност за живота при неспазване на посочените подолу инструкции за безопасност!</p> <p>Използвайте продуктите след като сте се запознали подробно с приложената към продукта документация и указания за безопасност, разбрали сте ги и сте се съобразили с тях.</p> <p>Ако текстът не е написан на Вашия език, моля обърнете се към Вашия компетентен търговски представител на Rexroth.</p> <p>Със задвижващите компоненти трябва да работи само квалифициран персонал.</p> <p>Подробни пояснения към инструкциите за безопасност можете да видите в Глава 1 на тази документация.</p>	<p><b>⚠ BRĪDINĀJUMS</b> Turpinājuma doto drošības norādījumu neievērošana var apdraudēt dzīvību!</p> <p>Sāciet lietot izstrādājumu tikai pēc tam, kad esat pilnībā izlasījuši, sapratuši un nēmuši vērā kopā ar izstrādājumu piegādātos dokumentus.</p> <p>Ja dokumenti nav pieejami Jūsu valsts valodā, vērsieties pie pilnvarotā Rexroth izplatītāja.</p> <p>Darbus pie piedziņas komponentiem drīkst veikt tikai kvalificēts personāls.</p> <p>Detalizētus paskaidrojumus attiecībā uz drošības norādījumiem skatiet šī dokumenta 1. nodaļā.</p>
<p><b>⚠ FIGYELMEZTETÉS!</b> Magas elektromos feszültség! Életveszély áramütés miatt!</p> <p>A hajtás alkatrészeit csak véglegesen telepített védővezetővel üzemeltesse!</p> <p>Mielőtt hozzányúl a hajtás alkatrészeihez, kapcsolja ki az áramellátást.</p> <p>Ügyeljen a kondenzátorok kisülési idejére!</p>	<p><b>⚠ ПРЕДУПРЕЖДЕНИЕ</b> Високо електрическо напрежение! Опасност за живота от удар от електрически ток!</p> <p>Работете със задвижващите компоненти само при здраво закрепен заземяващ проводник.</p> <p>Преди работа по задвижващите компоненти, изключете захранващото напрежение.</p> <p>Обърнете внимание на времето за разреждане на кондензаторите.</p>	<p><b>⚠ BRĪDINĀJUMS</b> Augsts elektriskais spriegums! Dzīvības apdraudējums elektriskā trieciena dēļ!</p> <p>Piedziņas komponentus darbiniet tikai ar fiksēti uzstādītu zemējumvadu.</p> <p>Pirms darba pie piedziņas komponentiem atslēdziet elektroapgādi.</p> <p>Nemiet vērā kondensatoru izlādes laikus.</p>

<b>H</b> Magyar	<b>BG</b> Български	<b>LV</b> Latviski
<p><b>▲ FIGYELMEZTETÉS!</b> Veszélyes mozgás! Életveszély!</p> <p>Ne tartózkodjon a gépek és a gépkatrészek mozgási területén belül!</p> <p>Illetéktelen személyeket ne engedjen a gép közelébe!</p> <p>Mielőtt beavatkozik, vagy a veszélyes zónába belép a hajtásokat biztonságosan állítsa le.</p>	<p><b>▲ ПРЕДУПРЕЖДЕНИЕ</b> Опасни движения! Опасност за живота!</p> <p>Не стойте в обсега на движение на машините и частите на машините.</p> <p>Не допускайте непреднамерен достъп на хора.</p> <p>Преди работа или влизане в опасната зона, спрете надеждно приводния механизъм.</p>	<p><b>▲ BRĪDINĀJUMS</b> Bīstamas kustības! Dzīvības apdraudējums!</p> <p>Neuzturieties mašīnu un mašīnas detaļu kustību zonā.</p> <p>Novērsiet nepiederošu personu piekļūšanu.</p> <p>Pirms darba bīstamajās zonās pilnībā apstādiniet piedziņu.</p>
<p><b>▲ FIGYELMEZTETÉS!</b> Elektromágneses / mágneses mező! Káros hatással lehet a szívritmus-szabályozó készülékkel, fémbelüktetéssel vagy hallókészülékkel rendelkezők egészségére!</p> <p>Azokra a területekre, ahol hajtások alkatrészeit szerelik és üzemeltetik, a fent említett személyeknek tilos a belépés, illetve csak orvosi konzultációt követően szabad az adott területekre lépniük.</p>	<p><b>▲ ПРЕДУПРЕЖДЕНИЕ</b> Електромагнитни / магнитни полета! Опасност за здравето на хора със сърдечни стимулатори, метални импланти или слухови апарати!</p> <p>Достъпът за гореспоменатите лица до зони, в които ще се монтират и ще работят задвижващи компоненти се забранява, или разрешава само след консултация с лекар.</p>	<p><b>▲ BRĪDINĀJUMS</b> Elektromagnētiskais / magnētiskais lauks! Veselības apdraudējums personām ar sirds stimulatoriem, metāliskiem implantiem vai dzirdes aparātiem!</p> <p>Tuvošanās zonām, kurās tiek montēti un darbināti piedziņas komponenti, iepriekš minētajām personām ir aizliegta, respektīvi, atļauta tikai pēc konsultēšanās ar ārstu.</p>
<p><b>▲ VIGYÁZAT!</b> Forró felületek (&gt; 60 °C)! Égésveszély!</p> <p>Ne érjen hozzá fémfelületekhez (pl. hűtőtестekhez)! Vegye figyelembe a hajtás alkatrészeinek kihűlési idejét (min. 15 perc)!</p>	<p><b>▲ ВНИМАНИЕ</b> Горещи повърхности (&gt; 60 °C)! Опасност от изгаряне!</p> <p>Не докосвайте метални повърхности (например радиатори). Съблюдавайте времето на охлаждане на задвижващите компоненти (мин. 15 минути).</p>	<p><b>▲ UZMANĪBU</b> Karstas virsmas (&gt; 60 °C)! Apdedzināšanās risks!</p> <p>Neskarīties pie metāliskām virsmām (piemēram, dzesētāja). Ļaujiet piedziņas komponentiem atdzist (min. 15 minūtes).</p>
<p><b>▲ VIGYÁZAT!</b> Szakszerűtlen kezelés szállításkor és szereléskor! Sérülésveszély!</p> <p>A megfelelő beszerelési és szállítási eljárásokat alkalmazza!</p> <p>Használjon megfelelő szerszámokat és személyes védőfelszerelést!</p>	<p><b>▲ ВНИМАНИЕ</b> Неправилно боравене по време на транспорт и монтаж! Опасност от нараняване!</p> <p>Използвайте подходящо монтажно и транспортно оборудване.</p> <p>Използвайте подходящи инструменти и лични предпазни средства.</p>	<p><b>▲ UZMANĪBU</b> Nepareizi veikta transportēšana un montāža! Traumu gūšanas risks!</p> <p>Izmantojiet piemērotas montāžas un transportēšanas ierīces.</p> <p>Izmantojiet piemērotus instrumentus un individuālos aizsardzības līdzekļus.</p>
<p><b>▲ VIGYÁZAT!</b> Akkumulátorok szakszerűtlen kezelése! Sérülésveszély!</p> <p>Üres akkumulátorokat ne aktiváljon újra, illetve ne töltsön fel (robbanás- és marásveszély)!</p> <p>Az akkumulátorokat ne szedje szét, és ne rongálja meg! Az akkumulátort ne dobja tűzbe!</p>	<p><b>▲ ВНИМАНИЕ</b> Неправилно боравене с батерии! Опасност от нараняване!</p> <p>Не се опитвайте да активирате отново или да зареждате разредени батерии (Опасност от експлозия и напръскване с агресивен агент).</p> <p>Не разглобявайте и не повреждайте батерии. Не хвърляйте батерии в огън.</p>	<p><b>▲ UZMANĪBU</b> Nepareiza bateriju lietošana! Traumu gūšanas risks!</p> <p>Nemēģiniet no jauna aktivizēt vai uzlādēt tukšas baterijas (eksploziju un ķīmisko apdegumu draudi).</p> <p>Neizjauciet un nesabojājiet baterijas. Nemetiet baterijas ugunī.</p>

<p style="text-align: center;"><b>LT</b> Lietuviškai</p>	<p style="text-align: center;"><b>EST</b> Eesti</p>	<p style="text-align: center;"><b>GR</b> Ελληνικά</p>
<p><b>⚠️ ISPĖJIMAS</b> Pavojus gyvybei nesilaikant toliau pateikiamų saugumo nurodymų!</p> <p>Naudokite gaminį tik kruopščiai perskaitę prie jo pridėtus aprašus, saugumo nurodymus. Susipažinkite su jais ir vadovaukitės naudodami gaminį.</p> <p>Jei Jūs negavote aprašo gimtąja kalba, kreipkitės į igaliotus Rexroth atstovus.</p> <p>Prie pavaros komponentų leidžiama dirbti tik kvalifikuotam personalui.</p> <p>Išsamesnius saugumo nurodymų paaiškinimus rasite šios dokumentacijos 1 skyriuje.</p>	<p><b>⚠️ HOIATUS</b> Alljärgnevatate ohutusjuhiste eiramine on eluohtlik!</p> <p>Võtke tooted käiku alles siis, kui olete toodetega kaasasolevad materjalid ning ohutusjuhised täielikult läbi lugenud, neist aru saanud ja neid järginud.</p> <p>Kui Teil puuduvad emakeelsed materjalid, siis pöörduge Rexrothi kohaliku müügiesinduse poole.</p> <p>Ajamikomponentidega tohib töötada üksnes kvalifitseeritud personal.</p> <p>Täpsemaid selgitusi ohutusjuhiste kohta leiate käesoleva dokumentatsiooni peatükist 1.</p>	<p><b>⚠️ ΠΡΟΕΙΔΟΠΟΙΗΣΗ</b> Κίνδυνος θανάτου σε περίπτωση μη συμμόρφωσης με τις παρακάτω οδηγίες ασφαλείας!</p> <p>Θέστε το προϊόν σε λειτουργία αφού διαβάσετε, κατανοήσετε και λάβετε υπόψη το σύνολο των οδηγιών ασφαλείας που το συνοδεύουν.</p> <p>Εάν δεν υπάρχει τεκμηρίωση στη γλώσσα σας, απευθυνθείτε σε εξουσιοδοτημένο αντιπρόσωπο της Rexroth.</p> <p>Μόνο εξειδικευμένο προσωπικό επιτρέπεται να χειρίζεται στοιχεία μετάδοσης κίνησης.</p> <p>Περαιτέρω επεξηγήσεις των οδηγιών ασφαλείας διατίθενται στο κεφάλαιο 1 της παρούσας τεκμηρίωσης.</p>
<p><b>⚠️ ISPĖJIMAS</b> Aukšta elektros įtampa! Pavojus gyvybei dėl elektros smūgio!</p> <p>Pavaros komponentus eksploatuokite tik su fiksuotai instaliuotu apsauginiu laidu.</p> <p>Prieš prieidami prie pavaros komponentų išjunkite maitinimo įtampą.</p> <p>Atsižvelkite į kondensatorių išsikrovimo trukmę.</p>	<p><b>⚠️ HOIATUS</b> Kõrge elektripinge! Eluohtlik elektrilõõgi tõttu!</p> <p>Käitage ajamikomponente üksnes püsival installaeritud maandusega.</p> <p>Lülitage enne ajamikomponentidega tööde alustamist toitepinge välja.</p> <p>Järgige kondensaatorite mahalaadumisaegu.</p>	<p><b>⚠️ ΠΡΟΕΙΔΟΠΟΙΗΣΗ</b> Υψηλή ηλεκτρική τάση! Κίνδυνος θανάτου από ηλεκτροπληξία!</p> <p>Θέτετε σε λειτουργία τα στοιχεία μετάδοσης κίνησης μόνο εφόσον έχει τοποθετηθεί καλά προστατευτικός αγωγός γείωσης.</p> <p>Πριν από οποιαδήποτε παρέμβαση, αποσυνδέστε την τροφοδοσία των στοιχείων μετάδοσης κίνησης.</p> <p>Λάβετε υπόψη τους χρόνους αποφόρτισης των πυκνωτών.</p>
<p><b>⚠️ ISPĖJIMAS</b> Pavojingi judesiai! Pavojus gyvybei!</p> <p>Nebūkite mašinų ar jų dalių judėjimo zonoje. Neleiskite netyčia patekti asmenims.</p> <p>Prieš patekdam į pavojaus zoną saugiai išjunkite pavaras.</p>	<p><b>⚠️ HOIATUS</b> Ohtlikud liikumised! Eluohtlik!</p> <p>Ärge viibige masina ja masinaosade liikumispiirkonnas.</p> <p>Tõkestage inimeste ettekavatsematu sisenemine masina ja masinaosade liikumispiirkonda.</p> <p>Tagage ajamite turvaline seiskamine enne ohupiirkonda juurdepääsu või sisenemist.</p>	<p><b>⚠️ ΠΡΟΕΙΔΟΠΟΙΗΣΗ</b> Επικίνδυνες τάσεις! Κίνδυνος θανάτου!</p> <p>Μην στέκεστε στην περιοχή κίνησης μηχανημάτων και εξαρτημάτων.</p> <p>Αποτρέψτε την τυχαία είσοδο ατόμων.</p> <p>Πριν από την παρέμβαση ή πρόσβαση στην περιοχή κινδύνου, μεριμνήστε για την ασφαλή ακινητοποίηση των συστημάτων μετάδοσης κίνησης.</p>
<p><b>⚠️ ISPĖJIMAS</b> Elektromagnetiniai / magnetiniai laukai! Pavojus asmenų su širdies stimulatoriais, metaliniais implantais arba klausos aparatais sveikatai!</p> <p>Prieiga prie zonų, kuriose montuojami ir eksploatuojami pavaros komponentai, aukščiau nurodytiems asmenims yra draudžiama arba leistina tik pasitarus su gydytoju.</p>	<p><b>⚠️ HOIATUS</b> Elektromagnetilised / magnetilised väljad! Terviseohtlik südamestimulaatorite, metallimplantaatide ja kuulmisseadmetega inimestele!</p> <p>Sisenemine piirkondadesse, kus toimub ajamikomponentide monteerimine ja käitamine, on ülalnimetatud isikutele keelatud või lubatud üksnes pärast arstiga konsulteerimist.</p>	<p><b>⚠️ ΠΡΟΕΙΔΟΠΟΙΗΣΗ</b> Ηλεκτρομαγνητικά/ μαγνητικά πεδία! Κίνδυνος για την υγεία ατόμων με καρδιακούς βηματοδότες, μεταλλικά εμφυτεύματα ή συσκευές ακοής!</p> <p>Η είσοδος σε περιοχές όπου πραγματοποιείται συναρμολόγηση και λειτουργία στοιχείων μετάδοσης κίνησης απαγορεύεται στα προαναφερθέντα άτομα, εκτός αν τους έχει δοθεί σχετική άδεια κατόπιν συνεννόησης με γιατρό.</p>
<p><b>⚠️ PERSPĖJIMAS</b> Karšti paviršiai (&gt; 60 °C)! Nudėgimo pavojus!</p> <p>Venkite liesti metalinius paviršius (pvz., radiatorių). Išlaikykite pavaros komponentų atvėsimą trukmę (bent 15 minučių).</p>	<p><b>⚠️ ETTEVAATUST</b> Kuumad välispinnad (&gt; 60 °C)! Põletusoh!</p> <p>Vältige metalsete välispindade (nt radiaatorid) puudutamist. Pidage kinni ajamikomponentide mahajahtumisaegast (vähemalt 15 minutit).</p>	<p><b>⚠️ ΠΡΟΣΟΧΗ</b> Καυτές επιφάνειες (&gt; 60 °C)! Κίνδυνος εγκαύματος!</p> <p>Αποφεύγετε την επαφή με μεταλλικές επιφάνειες (π.χ. μονάδες ψύξης). Λάβετε υπόψη το χρόνο ψύξης των στοιχείων μετάδοσης κίνησης (τουλάχιστον 15 λεπτά).</p>

LT Lietuviškai	EST Eesti	GR Ελληνικά
<p><b>⚠ PERSPĖJIMAS</b> Netinkamas darbas transportuojant ir montuojant! Susižalojimo pavojus!</p> <p>Naudokite tinkamus montavimo ir transportavimo įrenginius.</p> <p>Naudokite tinkamus įrankius ir asmens saugos priemones.</p>	<p><b>⚠ ETTEVAATUSTI</b> Asjatundmatu käsitsemine transportimisel ja montaažil! Vigastusoht!</p> <p>Kasutage sobivaid montaaži- ja transportiseadiseid.</p> <p>Kasutage sobivaid tööriistu ja isiklikku kaitsevarustust.</p>	<p><b>⚠ ΠΡΟΣΟΧΗ</b> Ακατάλληλος χειρισμός κατά τη μεταφορά και συναρμολόγηση! Κίνδυνος τραυματισμού!</p> <p>Χρησιμοποιείτε κατάλληλους μηχανισμούς συναρμολόγησης και μεταφοράς.</p> <p>Χρησιμοποιείτε κατάλληλα εργαλεία και ατομικό εξοπλισμό προστασίας.</p>
<p><b>⚠ PERSPĖJIMAS</b> Netinkamas darbas su baterijomis! Susižalojimo pavojus!</p> <p>Nebandykite tuščių baterijų reaktivuoti arba įkrauti (sprogimo ir išėsdinimo pavojus).</p> <p>Neardykite ir nepažeiskite baterijų.</p> <p>Nemeskite baterijų į ugnį.</p>	<p><b>⚠ ETTEVAATUSTI</b> Patareide asjatundmatu käsitsemine! Vigastusoht!</p> <p>Ärge üritage kunagi tühje patareisid reaktiveerida või täis laadida (plahvatus- ja söövitusoht).</p> <p>Ärge demonteerige ega kahjustage patareisid. Ärge visake patareisid tulle.</p>	<p><b>⚠ ΠΡΟΣΟΧΗ</b> Ακατάλληλος χειρισμός μπαταριών! Κίνδυνος τραυματισμού!</p> <p>Μην επιδιώκετε να ενεργοποιήσετε ξανά ή να φορτίσετε κενές μπαταρίες (κίνδυνος έκρηξης και διάβρωσης).</p> <p>Μην διαλύετε ή καταστρέφετε τις μπαταρίες. Μην απορρίπτετε τις μπαταρίες στη φωτιά.</p>

CN 中文
<p><b>⚠ 警告</b> 如果不按照下述指定的安全说明使用，将会导致人身伤害！</p> <p>在没有阅读，理解随本产品附带的文件并熟知正当使用前，不要安装或使用本产品。</p> <p>如果没有您所在国家官方语言文件说明，请与 Rexroth 销售伙伴联系。</p> <p>只允许有资格人员对驱动器部件进行操作。</p> <p>安全说明的详细解释在本文档的第一章。</p>
<p><b>⚠ 警告</b> 高压！电击导致生命危险！</p> <p>只有在安装了永久良好的设备接地导线后才可以对驱动器的部件进行操作。</p> <p>在接触驱动器部件前先将驱动器部件断电。</p> <p>确保电容放电时间。</p>
<p><b>⚠ 警告</b> 危险运动！生命危险！</p> <p>保证设备的运动区域内和移动部件周围无障碍物。</p> <p>防止人员意外进入设备运动区域内。</p> <p>在接近或进入危险区域之前，确保传动设备安全停止。</p>
<p><b>⚠ 警告</b> 电磁场/磁场！对佩戴心脏起搏器、金属植入物和助听器的人员会造成严重的人身伤害！</p> <p>上述人员禁止进入安装及运行的驱动器区域，或者必须事先咨询医生。</p>
<p><b>⚠ 小心</b> 热表面（大于 60 度）！灼伤风险！</p> <p>不要触摸金属表面（例如散热器）。驱动器部件断电后需要时间进行冷却（至少 15 分钟）。</p>
<p><b>⚠ 小心</b> 安装和运输不当导致受伤危险！当心受伤！</p> <p>使用适当的运输和安装设备。</p> <p>使用适合的工具及用适当的防护设备。</p>
<p><b>⚠ 小心</b> 电池操作不当！受伤风险！</p> <p>请勿对低电量电池重新激活或重新充电（爆炸和腐蚀的危险）。</p> <p>请勿拆解或损坏电池。请勿将电池投入明火中。</p>

# Table of Contents

	Page
<b>1 About this documentation.....</b>	<b>1</b>
1.1 Validity of this documentation.....	1
1.2 Editions of this documentation.....	1
1.3 Additional documentation.....	1
1.4 Presentation of information.....	1
<b>2 Safety instructions.....</b>	<b>3</b>
2.1 About this product.....	3
2.2 Intended use.....	3
2.3 Unintended use.....	3
2.4 Qualification of personnel.....	4
2.5 General safety instructions.....	4
2.6 Product- and technology-dependent safety instructions .....	4
2.6.1 Protection from electric voltage.....	4
2.6.2 Protection from mechanical danger.....	4
2.6.3 Protection against magnetic and electromagnetic fields.....	5
2.6.4 Protection during handling and assembly.....	6
2.6.5 Protection against burns.....	7
2.6.6 Electrostatic sensitive devices (ESD).....	8
<b>3 Scope of delivery.....</b>	<b>9</b>
<b>4 About this product.....</b>	<b>11</b>
4.1 Technical features.....	11
4.2 Identification of motor components.....	11
4.2.1 Position of type plate and serial number.....	11
4.2.2 Type plate ML3.....	12
<b>5 Transport and storage.....</b>	<b>13</b>
5.1 Notes about transport (shipping) instructions.....	13
5.2 Instructions on machine transport.....	13
5.3 Product storage.....	14
5.4 Storage times.....	14
<b>6 Assembly.....</b>	<b>15</b>
6.1 General notes.....	15
6.2 Mechanical assembly.....	15
6.2.1 Air-gap, parallelism and symmetry of the motor components.....	15
6.3 Assembly of primary parts.....	18
6.4 Installation of the secondary part segments.....	20
6.5 Cover plate installation (option).....	24
6.5.1 Notes.....	24

## Table of Contents

	Page
6.5.2	Installation..... 24
6.6	Hall unit installation (option)..... 26
6.6.1	Analog Hall unit..... 26
6.6.2	Digital Hall unit..... 27
6.7	Electrical connection..... 28
6.7.1	Connection cable on primary part..... 28
6.7.2	Electrical connection primary part..... 29
6.7.3	Routing of connection cables..... 31
6.7.4	Connection designations at Rexroth controllers..... 34
6.7.5	Rexroth connection cable for ML3 motors..... 35
6.7.6	Electrical connection of Hall unit (optional)..... 35
<b>7</b>	<b>Commissioning and operation..... 41</b>
7.1	Safety..... 41
7.2	Commissioning..... 41
7.3	Operation..... 42
<b>8</b>	<b>Maintenance and repair..... 43</b>
8.1	Cleaning and servicing..... 43
8.2	Service repair, maintenance and spare parts..... 44
<b>9</b>	<b>Disassembly..... 47</b>
<b>10</b>	<b>Environmental protection and disposal ..... 49</b>
<b>11</b>	<b>Troubleshooting..... 51</b>
11.1	Procedure..... 51
<b>12</b>	<b>Declaration of conformity..... 53</b>
	<b>Index..... 55</b>

# 1 About this documentation

## 1.1 Validity of this documentation

This instruction has to be complied with by assemblers, operator, service engineers and facility operators. It contains notes about handling the motor components primary and secondary part of a ML3 kit motor.

Before operating motors, read this operating instruction to ensure a safe and smooth functionality and a long motor lifetime.



## 1.2 Editions of this documentation

Edition	Release date	Notes
01	2018-06	First edition
02	2018-12	Update of technical data with motor characteristic curves
03	2019-05	Update of technical data, dimension sheets and assembly notes
04	2021-10	EAC label removed

Tab. 1-1: Record of revisions

## 1.3 Additional documentation

This operating instruction is only valid with the following Rexroth documentation:

	Title	Document type	Document number
	ML3 Self-cooled linear motors	Project Manual Planning	DOK-MOTOR*-ML3x*****-PR□□-□□-P
	Electromagnetic Compatibility (EMC) in Drive and Control Systems	Project Manual Planning	DOK-GENERL-EMV*****-PR□□-□□-P
	Documentation about special products are available on demand.		

Tab. 1-2: Additional documentation

## 1.4 Presentation of information

**Safety instructions** The safety notes in this documentation describe signal words (danger, warning, caution, note) and a signal symbol (acc. to ANSI Z535.6-2011).

The signal word is intended to draw your attention to the safety instructions and describes the seriousness of the danger. The warning triangle with exclamation mark indicates the danger for persons.

 **DANGER**

Non-compliance with this safety instructions **will** result in death or severe personal injury.

**⚠ WARNING**

Non-compliance with this safety instructions **can** result in death or severe personal injury.













**⚠ CAUTION**

Non-compliance with this safety instructions can result in moderate or minor personal injury.

**NOTICE**

Non-compliance with this safety instructions can result in material damage.

**Symbols**

Symbol	Meaning
	Reference to supplementary documentation
	This note gives important information, which must be observed.
	Single, independent handling step
1. 2. 3.	Numbered instruction: The numbers show that the action steps must be taken one after the other.
	Warning against dangerous electric voltage.
	Warning against hot surfaces.
	Warning against rotating machine parts.
	Warning against overhead load.
	Warning against crushing hazard.
	Electrostatic sensitive devices.
	Access for persons with cardiac pacemaker forbidden.
	Do not carry along metal parts or clocks.
	Hammer scales are forbidden.

Tab. 1-3: *Meaning of symbols*

## 2 Safety instructions

### 2.1 About this product

Observe the general safety notes in this chapter and the safety instructions in this documentation. Therewith, you avoid personal danger, damage and errors.



This operating instruction must be stored and transferred in case of sale during the complete product lifetime.

---

### 2.2 Intended use



Handle all motor components carefully, in all kinds of situations. Pay close attention to the safety notes and notes regarding the magnetic pull of the permanent magnets on the secondary part.

---

Prerequisites for proper and safe use of the motors are proper transport, appropriate storage, proper assembly and connection, careful maintenance, operation and overhaul.

The motors have been designed for installation in industrial machinery. The motors are according to the following standards and directives.

#### Standards

---

DIN EN 60034-1	Rating and performance behavior
DIN EN 60034-5	Degree of protection

#### Directives

---

2014/35/EU	Low voltage directive
------------	-----------------------

The machine manufacturer must evaluate the electric and mechanic safety as well as environmental influences in the assembled state of the machine according to the Machine Directive 2006/42/EC and DIN EN 60204-1 (safety of machines).

The electrical installation must comply with the protection requirements of EMC Directive 2014/30/EU. The plant manufacturer is responsible for appropriate installation (for example: physical separation of signal and power cables, using shielded cables, ...). The EMC instructions of the converter manufacturer must be observed.

Start-up is prohibited as long as the conformity with these directives is declared.

### 2.3 Unintended use

Any use of the motors outside of the specified fields of application or under operating conditions and technical data other than those specified in this documentation is considered to be "inappropriate use".

Direct operation on the three-phase network and in explosion-hazardous areas (ATEX) is forbidden.

#### Trademark right third parties

Observe the trademark rights of third parties during assembly and use of single components delivered from Bosch Rexroth. For any infringement of the right, the customer is liable for the accruing damage.

## 2.4 Qualification of personnel

This operating instruction is intended for persons, who are familiar with transportation, installation, assembly, start-up and operation of components of electric drive and control systems and therewith associated danger and they must have appropriate qualifications.

All persons, working on, with or near an electric facility, must know the safety requirements, safety instructions and operating instructions (DIN EN 50110-1).

## 2.5 General safety instructions

Do not install or operate motors or components of an electric drive and control system, as long as you have not read and understood all relevant documents.

Please observe the respectively valid national, local and plant-specific regulations, the safety notes in the documentation and the warning signs on the components.

**Improper use of the components and non-observance of the described safety notes can lead to damage, bodily injury, electric shock or in extreme case lead to death.**

In the case of damage due to non-observance of the safety notes, Bosch Rexroth assumes no liability.

## 2.6 Product- and technology-dependent safety instructions

### 2.6.1 Protection from electric voltage

**Work required on the electric system may only be carried out by skilled electricians. Tools for electricians (VDE tools) are absolutely necessary.**

Before working:

1. Enable.
2. Secure against reactivation.
3. Ensure de-energization.
4. Ground and short-circuit.
5. Cover or shield any adjacent live parts.

After completing the job, cancel the measures in reverse order.

**Dangerous voltage occurs during operation! Danger to life, risk of injury by electric shock!**

- Before start-up, connect the protective conductors on all electric components according to the connection plan.
- Operation, even for short measuring purposes is only allowed with fixed connected protective conductor on the specified points of the components.

### 2.6.2 Protection from mechanical danger

**Dangerous movements! Danger to life, risk of injury, heavy injury or material damage.**

- Do not stay within the motion zone of the machine. Avoid unauthorized access into the danger zone.

- Additionally secure vertical axes to prevent them from sinking or descending after having shutdown the motor, for instance as follows:
  - mechanically lock the vertical axis,
  - providing an external braking / catching / clamping device, or
  - ensuring sufficient equilibration of the vertical axis.

### 2.6.3 Protection against magnetic and electromagnetic fields

Magnetic and electromagnetic fields are created in the direct environment of live conductors or permanent magnets of electro motors and are a serious danger for persons. The machine operator must sufficiently protect personnel working in these areas from possibly occurring damage by suitable measures (e.g. warning notes, protective clothes, designation of the danger zone). Observe the safety instructions [chapter 2.6.4 "Protection during handling and assembly" on page 6](#).

Observe the country-specific regulations. For Germany, please observe the specifications of the occupational insurance association BGV B11 and BGR B11 regarding "electromagnetic fields".

#### **Electro magnetic and magnetic fields!**

#### **Danger for persons with active body aids or passive metallic implants and for pregnant women.**

- For persons with active body aids (like heart pacemakers), passive metallic implants (like hip prosthesis) and pregnant women possible hazards exist due to electro magnetic or magnetic fields in direct environment of electric drive and control components and the corresponding live conductors.

Access into these areas can be dangerous for these persons:

- Areas, in which components of electrical drive and control systems and corresponding live conductors are mounted, activated or operated.
- Areas in which motor parts with permanent magnets are stored, repaired or assembled.
- Above mentioned persons must contact their attending physician before entering these areas.
- Please observe the valid industrial safety regulations for plants which are fitted with components of electrical drive and control systems and corresponding live conductors.

#### **Risk of destruction of sensitive parts! Data loss!**

- Keep watches, credit cards, check cards and identity cards and all ferromagnetic metal parts, such as iron, nickel and cobalt away from permanent magnets.

#### **Crushing hazard of fingers and hand due to heavy attractive forces of the magnets!**

The attractive force of the permanent magnets have an effect on all magnetic materials. These attractive forces surge especially within a neighborhood < 100 mm. Loose or not fastened components made of magnetizable materials can abruptly and inadvertently attracted with the permanent magnets. Apart from crushing hazard, even the danger of chipping recalcitrant material, causing eye injury, exists.

- Extreme caution during handling of motor components with permanent magnets. Do never underestimate strong attractive forces.
- Never work alone.
- Use personal safety equipment (e.g. protective gloves, protective glasses).
- Unpack single motor components with permanent magnets immediately prior mounting.
- Do not unpack several motor components with permanent magnets or directly place them side by side at your working space.
- Do not bring magnetized or magnetizable materials in the area of permanent magnets. If using magnetizable tools cannot be avoided, hold on the tool very tight, move carefully and observe the attractive force effect of the permanent magnets.

#### **Behavior in the case of accidents with permanent magnets**

During work with permanent magnets, the following emergency tools must be ready to use in the case of an accident to release impacted body parts (like fingers, hands, arms a.s.o.):

- Hammer (3-5kg) made of non-magnetized material like brass
- Minimum 2 wedges with approx. 10 - 15 ° lip angles made of non-magnetized material like brass, wood or similar to impact driving into the cutting slit.
- A crowbar made of brass.

#### **In the case of an accident:**

- Keep calm!
- If the machine is live, immediately de-energize (emergency button).
- Give first aid or request appropriate help (e.g. emergency doctor).
- Disconnect magnetic adherent parts with the emergency tools. Therefore, beat the wedges with a hammer into the cutting slit to free the caught body parts.

## **2.6.4 Protection during handling and assembly**

Motor components with permanent magnets (e.g. secondary parts of a synchronous linear motor or rotor of a synchronous kit motor) create very strong attractive forces from ferromagnetic parts like further motor components with permanent magnets or parts of iron, nickel or cobalt.

Please observe the safety notes about strong attractive forces of permanent magnets under [chapter 2.6.3 "Protection against magnetic and electromagnetic fields"](#) on page 5.

The attractive forces of the permanent magnets influence all magnetizable materials. Especially in an area < 100 mm, the attractive forces rise. Surrounding components can abruptly and inadvertently be attracted by the permanent magnets. Apart from crushing hazard, even the danger of chipping recalcitrant material, causing eye injury, exists.

Use the origin package of the motor components for transport and storage only. The origin package of Rexroth is constructed in such a way that the motor components with the permanent magnets are positioned within the package with suitable distance, providing that the package is correctly used.

Observe the following instructions during unpacking and handling.

- Instruct the personal with regard to the danger.
- Use personal safety equipment (e.g. protective gloves, protective glasses).
- Store all components in its origin package until assembly and for transport.
- Do only work on clean working spaces in which no ferromagnetic parts exist.
- If possible, use non-magnetic tools, e.g. made from aluminum or brass.
- Remove only one motor component from the package and secure it on your working space against slipping, rolling away.

Instruct all participating persons about the dangers and if necessary, expand the preliminary instructions.

**Store the original package of the motor components with permanent magnets**

Store the original package for later use.

In the case of reuse, ensure a good readability of the safety notes on the package. They must not be paste over!

**Risk of injuries due to improper handling! Bodily injury due to crushing, scissors, cutting, punching!**

- Observe the instructions on the package.
- Store the motor components with permanent magnets in the original package, only.
- Do not internally store or transport the motor components unpacked.
- Observe the accident prevention regulations.
- Use suitable assembly and transport equipment.
- Prevent clamping and squeezing by means of suitable measures.
- Use suitable tools, if necessary use special tools.
- Properly use lifting devices and tools.
- Use suitable safety equipment (like protective helmets, protective glasses, safety shoes, protective gloves).
- Never walk under hanging loads.
- Immediately remove spill on the ground, otherwise risk of falling!

## 2.6.5 Protection against burns

**Risk of burns due to hot motor surfaces!**

- Avoid contact with hot motor surfaces. **Temperatures may rise over 60 °C.**
- Allow the motor components to cool down long enough before touching them.
- Temperature-sensitive components may not come into contact with the motor surface. Ensure appropriate mounting distance of connection cables and other components.

## 2.6.6 Electrostatic sensitive devices (ESD)

Rexroth motors contain parts which underlie an electrostatic danger. These components, especially temperature sensors of the motor winding can be destroyed by improper use.

Avoid, e.g. direct contact of open wires of the connection cable of temperature sensors without being electrostatically discharged or grounded.



Do suitable ESD protective measures before you handle imperiled components (e.g. ESD protective clothes, wristlets, conductive floor, grounded cabinets and working surfaces).

---

### 3 Scope of delivery

The motor components are individually packaged in a box. For identification, the package is marked with a label similar to the type plate with the type designation of the components.

#### Scope of delivery ML3P primary part

The scope of delivery of a primary part contains:

- Primary part in origin package
- Safety instructions
- Additional rating plate



For legal reasons, the enclosed type plate does not contain a CSA mark.

---

#### Scope of delivery ML3S secondary part



On delivery, the secondary parts are fitted with magnetic transport and assembly protection. It consists of a rubber mat with a thickness of approx. 5 mm connected with a ferromagnetic cover plate. For safety reasons, the transport and assembly protection should not be removed from the ML3S until installation. When using the protection cover, make sure that the rubber side is always in contact with the magnets.

---

The scope of delivery of a secondary part contains:

- Secondary part in origin package
- Type plate
- Safety instructions

On delivery, immediately verify whether the delivered goods are those specified on the delivery note. The forwarder must be promptly informed of any damage on the packaging and goods, which is detected on delivery. Start-up of damaged goods is prohibited.



## 4 About this product

### 4.1 Technical features

<b>Product</b>	Three phase synchronous motor
<b>Manufacturer</b>	Bosch Rexroth Electric Drives and Controls GmbH Buergermeister-Dr.-Nebel-Straße 2 97816 Lohr am Main, Germany
<b>Type</b>	Primary part <b>ML3P03</b> , -06, -11 Secondary part <b>ML3S03</b> , -06, -11
<b>Listed acc. to CSA standard</b>	CSA-File Number 271353
<b>Motor design</b>	Open (kit motor)
<b>Degree of protection</b>	IP40 (IP64) (DIN EN 60034-5)
<b>Sound pressure level</b>	< 75 dB(A)
<b>Insulation class</b>	130 (DIN EN 60034-1)
<b>Electrical connection</b>	Connection cables
<b>Installation altitude and ambient temperature during operation</b>	Please also observe the information provided in the project planning manual.



In the case of special design, details named in the operating instructions can deviate. In this case, order the supplementary documentation.

## 4.2 Identification of motor components

### 4.2.1 Position of type plate and serial number

The motor components can be identified via a type plate and an engraved serial number

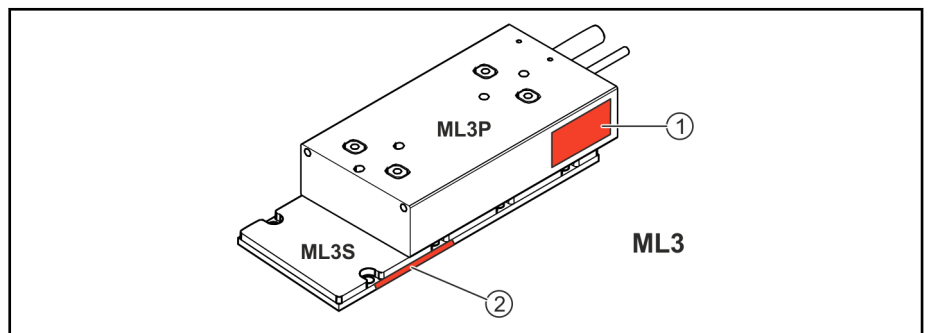

- ① Position of the type plate on the primary part
- ② Position of engraved serial number on the secondary part

Fig. 4-1: Position of component designation

### 4.2.2 Type plate ML3

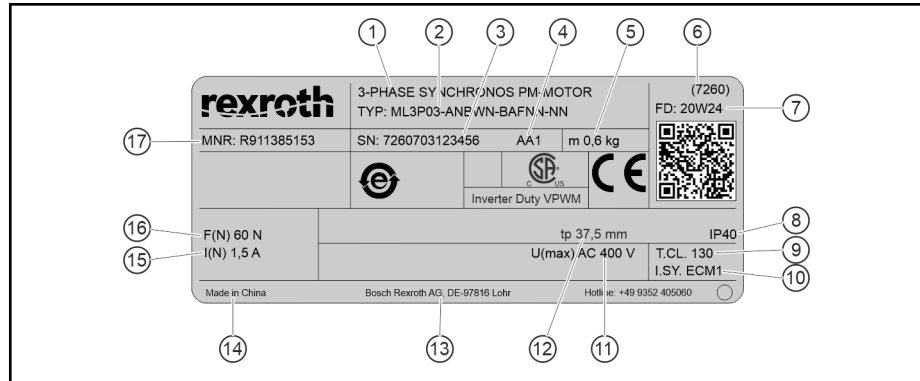

- 1 Motor type
- 2 Type designation
- 3 Serial number
- 4 Change status
- 5 Mass
- 6 Factory number
- 7 Date of manufacture
- 8 Degree of protection by housing
- 9 Thermal class
- 10 Insulation system
- 11 Maximum voltage CSA
- 12 Pole pitch
- 13 Company address
- 14 Designation of origin
- 15 Rated current
- 16 Continuous force at standstill
- 17 Material number

Fig. 4-2: Type plate (example)

Certification mark	Certification mark	Significance
		CSA conformity
		Conformity with applicable EC Directives
		RoHS 2 conformity

Tab. 4-1: Certification mark at type plate

For further information about the certification mark please refer to the project planning manual (see table [Other applicable documents](#)) of these motors.

## 5 Transport and storage

### 5.1 Notes about transport (shipping) instructions

#### WARNING

Strong attractive forces due to permanent magnets on the secondary part! Risk of injury and danger of crushing body parts by magnetic forces!

- Please note the safety instructions [Chapter 2.6.3](#) and [Chapter 2.6.4](#).
- Remove the ML3S transport and assembly protection just before or during the assembly. Make sure that no small ferromagnetic parts like screws get into contact with the magnets or secondary parts.

The motor components (primary and secondary part) must be transported in their original package taking classes 2K2, 2B1, 2C2, 2S1, 2M2 specified acc. to DIN EN 60721-3-2 into account.

Transport by air freight

#### CAUTION

Possible influence of plane electronic on board through magnet fields!

If secondary parts are not forwarded in the unopened Rexroth original packaging, applicable packaging and transport regulations must be observed (IA-TA 953).

### 5.2 Instructions on machine transport

#### CAUTION

Risk of injuries and/or damage when handling unpacked secondary parts!

- When handling secondary parts, please observe the warnings under [chapter 2.6 "Product- and technology-dependent safety instructions"](#) on page 4 and make sure that they are kept.
- Remove the ML3S transport and assembly protection just before or during the assembly. Make sure that no small ferromagnetic parts like screws get into contact with the magnets or secondary parts.



Transport the secondary part in its original packing to the place of assembly and let it be packed until it must be mounted. Store the original packing after assembly of the secondary part for further use (e.g. re-storage or return). Observe a proper state and good visibility of the affixed warning notes.

The MC 3motor components can be transported by hand. The mass of the single components is 0.6 kg up to 11.6 kg, depending from their frame size.

#### NOTICE

Never touch the connection points of electrostatic sensitive devices!



Mounted components (e.g. KTY) can contain parts susceptible to electrical discharge (ESD).

- ▶ Observe the ESD safety measures.

**⚠ WARNING**

**Material damage due to improper handling during transport!**



- ▶ Do not lift or move the primary part on the cable strand.

## 5.3 Product storage

Store the motor components in their original package at a dry, dust free, vibration free and light protected place without direct solar radiation. Observe the specified classes 1K3, 1B1, 1C2, 1S1, 1M1 of DIN EN 60721-3-2 for storage.

**NOTICE**

**Damage due to moisture and humidity!**

- ▶ Use coverings to protect the products from moisture.
- ▶ Store them only in rainproof and dry rooms.

Upon delivery, protective sleeves and covers can be attached to Bosch Rexroth motors. They have to remain on the motor for transport and storage. Remove the ML3S transport and assembly protection just before or during the assembly. Make sure that no small ferromagnetic parts like screws get in contact with the magnets or secondary parts.

## 5.4 Storage times

Independend from the storage time of the motor components (observe the warranty claim), the function is preserved under observance and execution of additional measures at start-up.

### Cables and connectors

Storage time	Measures prior to commissioning
< 1 year	None
1 ... 5 years	▶ Check the electric contacts to verify that they are free from corrosion
> 5 years	▶ Check the electric contacts to verify that they are free from corrosion ▶ Visually inspect the cable jacket. Do not use the cable if you detect any abnormalities (squeezed or kinked spots, color deviations, ...).

*Tab. 5-1: Measures before commissioning of cables and connectors that have been stored over longer periods of time*

## 6 Assembly

### 6.1 General notes



The machine manufacturer has to consider the special character of their construction and must work out special mounting instructions for the motor components primary and secondary part. The machine manufacturer's mounting instructions are the only binding guidelines.

The range and order of installation of motor components is depending on the machine construction or the available space in the machine. Also, the arrangement of the motor components plays a significant role.

The project planning manual ML3 contains a suggestion to assemble motor components. This suggestion can be understood as a guideline to estimate the necessary assembly effort and to prepare the necessary implements for assembly.

The following points must be considered or checked before starting the assembly work:

- Observation of the necessary installation sizes (see [Mechanical installation](#))
- Machine construction fulfills the requests for mounting (stiffness, attractive force, feed and acceleration force, etc.) and is prepared for installation of the motor components.
- Clean screw-on surfaces between machine and motor components
- Installation of motor components by skilled personnel only
- Compliance of danger and safety notes is guaranteed.

#### Screw lock

All screwed connections must be secured against potential impacts and vibrations during operation of the machine. A suitable and field-tested screw lock for all metal thread connections is, e.g., Loctite 243.

Loctite 243 is a liquid screw lock (medium-hard) and is applied to the parts to be mounted immediately prior to assembly. For detailed information on correct handling and processing, please refer to the manufacturer's data sheets under <http://www.loctite.de>. The manufacturer's homepage also provides information on hardening accelerators or other screw locks.

## 6.2 Mechanical assembly

### 6.2.1 Air-gap, parallelism and symmetry of the motor components

#### Parallelism and symmetry

When mounting primary and secondary parts, their position is specified by the holes or threads within the machine slide and prepared within the machine bed. If all installation dimensions were adhered to, the correct arrangement of both motor components to each other results. Take the values of installation dimensions from the following table [Tab. 6-1](#)

The exact dimensions and specifications for form and position tolerances can be taken from [Fig. 6-2](#)

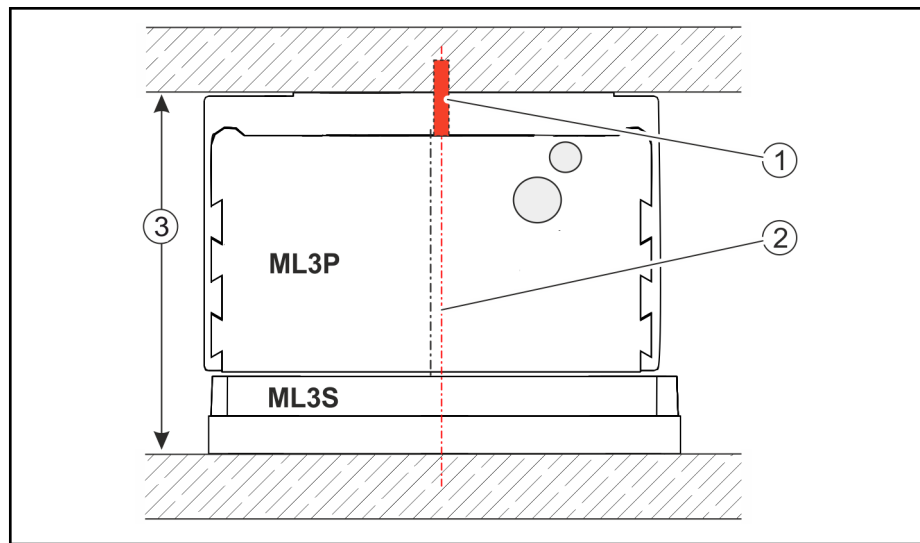

- ① Dowel holes within the primary part
- ② Magnetic and mechanic center line of the magnetic plate
- ③ Installation height (see Fig. 6-1)

Fig. 6-1: *Aligning the motor components*

The primary part is not symmetrically placed over the secondary part, as the winding within the primary part is not centered.

**Installation height without cover plate**

Due to keeping the specified installation height at the bottom of the secondary part up to the top of the primary part, the necessary air gap arises and the motor reaches its projected power data.

**NOTICE** Motor damage due to insufficient air gap between primary and secondary part!

After assembly, check the free movement of the motor components to each other immediately. Therefore, move the versatile motor components by hand over the complete travel length. The versatile motor components must be freely movable at each position over the total travel length - without any contact to fixed motor components. This check can detect faulty assembly in time ( e.g. dirt under the assembly surfaces, faulty installation dimensions, insufficient machine rigidity etc.).

The following specifications on the air gap refer to the use of secondary parts without cover plate. If cover plates are used, the air gap must be increased by the thickness of the cover plates Tab. 6-2.

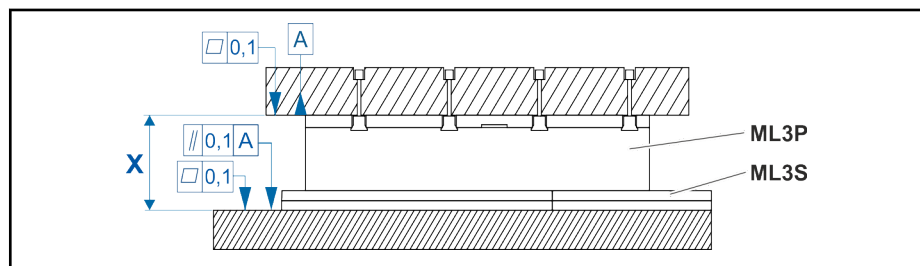

X Installation height (see Tab. 6-1)

Fig. 6-2: *Values for levelness and parallelism*

Installation height with cover plate  
(option)

Frame size	Installation height "X"
ML3x03	40 mm ± 0.1 mm
ML3x06	40 mm ± 0.1 mm
ML3x11	45 mm ± 0.1 mm

Tab. 6-1: Installation height ML3 motors without cover plate

The plate dimensions are to be selected according to the following table:

Frame size	Cover plate		Installation height "X" with cover plate
	Thickness	Width	
03	0.15 ± 0.02 mm	50 mm (49.8 - 50.5 mm)	40.17 ± 0.1 mm
06		80 mm (79.8 - 80.5 mm)	
11		130 mm (129.8 - 130.5 mm)	45.17 ± 0.1 mm

Tab. 6-2: ML3 Motors installation height with cover plate

**⚠ CAUTION**

**Damage or destruction of motor components due to use of cover plates!**

- If the installation height of the motor is not adjusted when a cover plate is used (increased), motor components of the ML3 may be damaged or destroyed.
- The cover plate must be earthed according to the state of the art. The ML3S must not be used for this.

Checking the minimum air gap between primary and secondary part after the assembly is recommended

For this reason, insert a test strip made of non-magnetic material (copper, plastics, etc.) with a thickness of

- **0.4 ... 0.5 mm**

into the air gap between primary and secondary part. The test strip must be versatile in the air gap on every position of the total length via the complete surface of the primary part.

This measure ensures the minimum necessary air gap between the motor components. This check can detect faulty assembly in time ( e.g. dirt under the assembly surfaces, faulty installation dimensions, insufficient machine rigidity etc.).



If the installation height and thus the height of the air gap is exceeded above the tolerances, this leads to an exponential deterioration of the linear motor specifications. A too small air gap can lead to damage or destruction of the motor.

## 6.3 Assembly of primary parts



To fasten the primary part, only new, unused screws must be used.

- Only use specified screws (see Fig. 6-3).
- Tighten all screws crosswise with the necessary tightening torque - from inside to outside.
- Lock screw connection with Loctite 243, for example (observe the notes of the adhesive manufacturer).
- When using dowels, ensure that they do not protrude more than specified in the dimension sheets. The primary part could be damaged.
- After assembly, check if any foreign bodies exist between primary and secondary part.

### Fastening screws

Frame size	Screw size	Screw-in depths	Strength class	Tightening torque (± 10 %)
ML3P03	M4 (DIN EN ISO 4762)	min. 4 mm	8.8	3.1 Nm
ML3P06	M5 (DIN EN ISO 4762)	max. 5 mm		6.1 Nm
ML3P11	M5 (DIN EN ISO 4762)	min. 4.5 mm max. 6 mm		6.1 Nm

Tab. 6-3: Fastening screws with tightening torques for ML3P primary parts

### Dowels

Size primary part	Dowels (rust-free)
ML3P03 ... 11	5h8 (with internal thread M3 for disassembly)

Tab. 6-4: Dowels for ML3P primary part

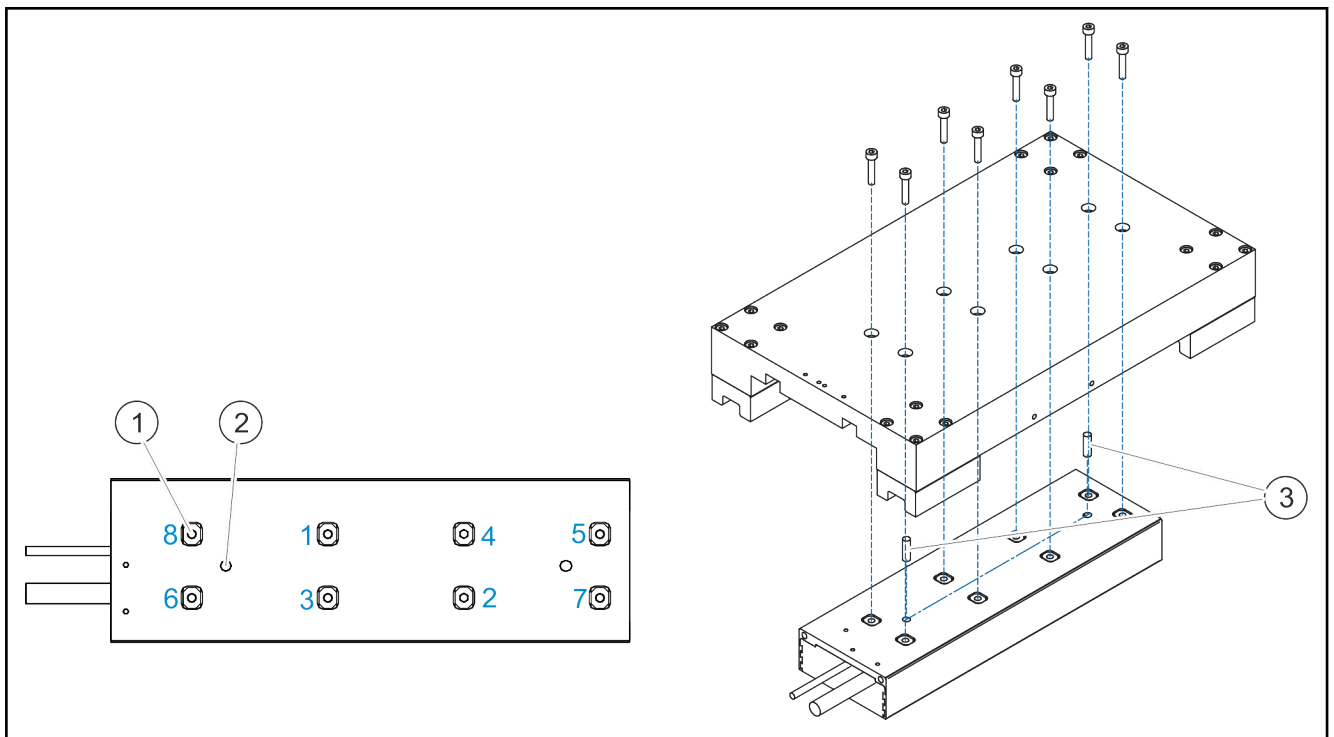

- ① Fastening tread  
 ② Dowel holes (blind holes)

1 / 2 / 3 ...

#### Tightening sequence

- ③ Dowels

Fig. 6-3: Tightening sequence fastening screws of primary part

The screw-on surfaces must be cleaned and be free of grease before the primary parts can be screwed on the machine construction.

#### Mounting instructions:

1. Insert the dowels into the dowel holes in ML3P and position the primary part on the slide.



When using dowels, ensure that they do not protrude more than specified in the dimension sheets. This can lead to damage of the primary part.

2. Fasten the primary part with screws 1, 2, 3 ...x crosswise until the primary part is in contact with the slide.
3. Tighten all screws in the same tightening row with the nominal tightening torque.



The effect of liquid screw lock is damaged by loosening or re-tightening of screws (e.g. due to torque tests) and must be renewed. Observe the instructions of the adhesive manufacturer about correct screw lock.

## 6.4 Installation of the secondary part segments

### WARNING

Danger due to permanent magnets!



▶ Health hazard for persons with heart pacemakers, metallic implants and hearing aids in direct environment of permanent magnets.



▶ Crushing hazard of fingers and hand due to heavy attractive forces of the magnets.



▶ Risk of destruction of sensitive parts such as watches, credit cards, ...



To fasten the secondary parts, it is only allowed to use new, unused screws.

- Only use specified screws (see [Fig. 6-5](#)).
- Tighten all screws with the necessary tightening torque.
- Lock screw connection with Loctite 243, for example (observe the notes of the adhesive manufacturer).
- When using dowels, ensure that they do not protrude more than specified in the dimension sheets. The secondary part could be damaged.
- After assembly, check that there are no foreign objects on the secondary part.

Short distances consisting of a maximum of 6 ML3S can be built up by placing the secondary parts next to each other. If distances of more than 2m are provided or are analog Hall units used, ensure correctly aligned secondary parts by using dowel holes and dowel pins (also refer to [Fig. 6-4](#)).

The screw-on surfaces and stop faces must be cleaned and be free of grease before the secondary parts can be screwed on the machine construction. The tightening torques of the fastening screws is specified in the following table:

Frame size	Screw size	Screw-in depths	Strength class	Tightening torque (+/- 10%)
ML3S03	M5x10 (DIN EN 7984)	min. 6.5 mm	8.8	6.1 Nm
ML3S06				
ML3S11	M5x16 (DIN EN ISO 4762)			

Tab. 6-5: Fastening screws with tightening torques for ML3S secondary parts

The calculation of screw connection for fastening the secondary part are based on the assumption that the screwing surface of the secondary part and the screwing surface of the machine is clean and the secondary part is screwed in direct contact with the machine.



- In certain cases, it is not possible to screw the secondary part in direct contact with the machine as additional materials like distance plates, thermal grease and so on, are between the secondary part and the machine. Then a sufficient fastening of the screw connection must be ensured by the machine manufacturer.
- The effect of liquid screw lock is damaged by loosening or re-tightening of screws (e.g. due to torque tests) and must be renewed. Observe the instructions of the adhesive manufacturer about correct screw lock.

## Dowels on ML3S



When using dowels, ensure that they do not protrude more than specified in the dimension sheets. This can lead to damaged secondary parts.

Frame size secondary part	Dowels (rust-free)
ML3S03 ... 11	5h8 (with internal thread M3 for disassembly)

Tab. 6-6: Dowels for ML3S secondary parts

## Segmented secondary part

**WARNING**

**Risk of injuries or material damage due to attractive or repulsive force at concatenation of secondary part segments!**



- Secure against uncontrolled movement
- Observe correct concatenation of secondary part segments
- Remove the transport or assembly protection only when or after mounting into the machine

If several secondary part segments are used over the whole travel length, keep the poles and the flush direction at concatenation according to the following figure.

A correct assembly can be ensured as follows:

1. Insert dowels for the first secondary part into the holes on the machine bed.



When using dowels, ensure that they do not protrude more than specified in the dimension sheets. This can lead to damaged secondary parts.

2. Place the secondary part in such a way that the dowels grab into the secondary part and set down slowly.
3. Fasten the secondary part with screws.
4. As necessary, install additional secondary parts in the same order. The secondary part that is installed last must have a minimum clearance of 10 cm to the primary part.

## Assembly

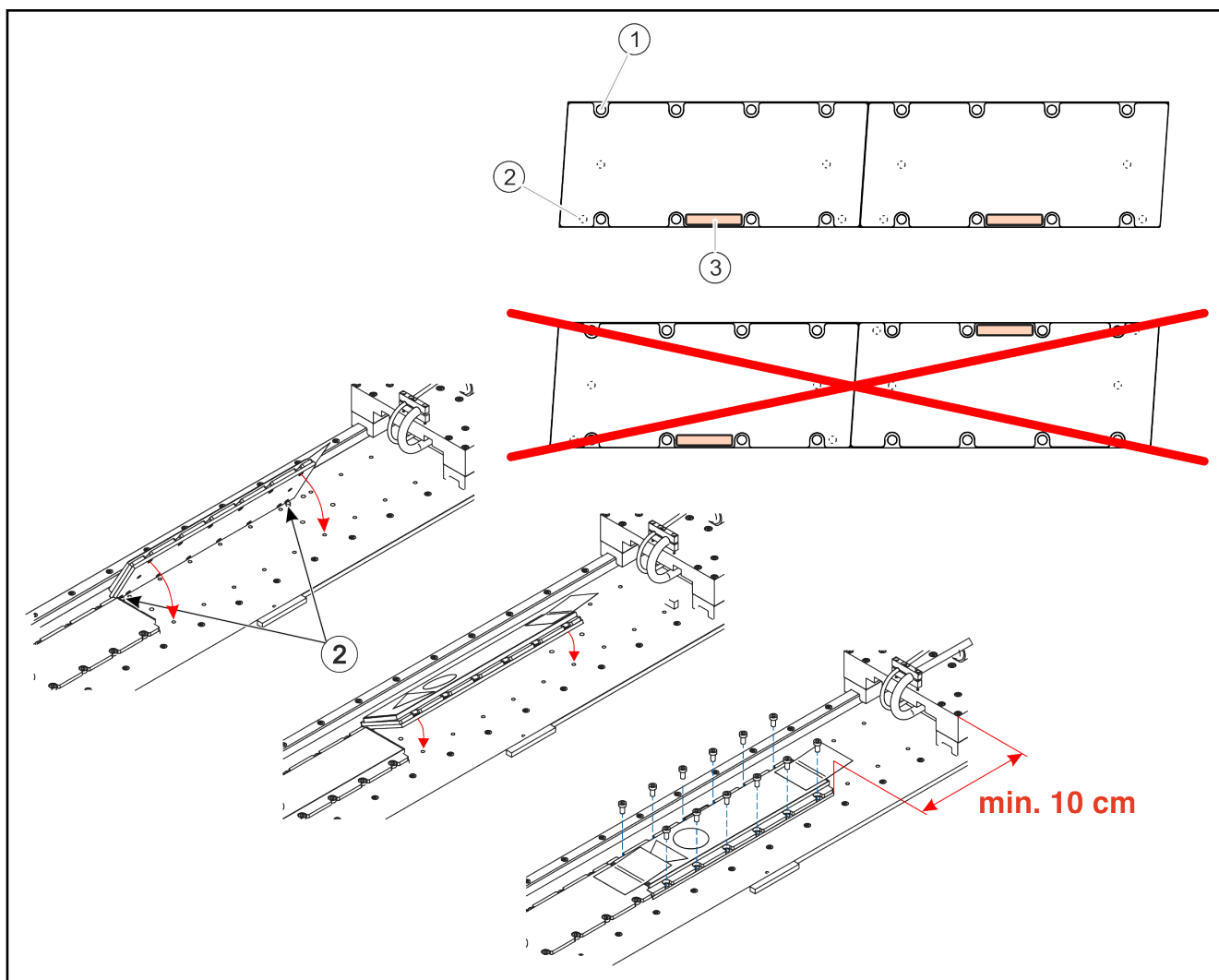

- ① Mounting holes
- ② Dowel holes (blind hole at the bottom)
- ③ Reference marks

Fig. 6-4: Mounting holes, dowel holes and reference marks at ML3S

5. Remove the transport and assembly protection at installed secondary parts.

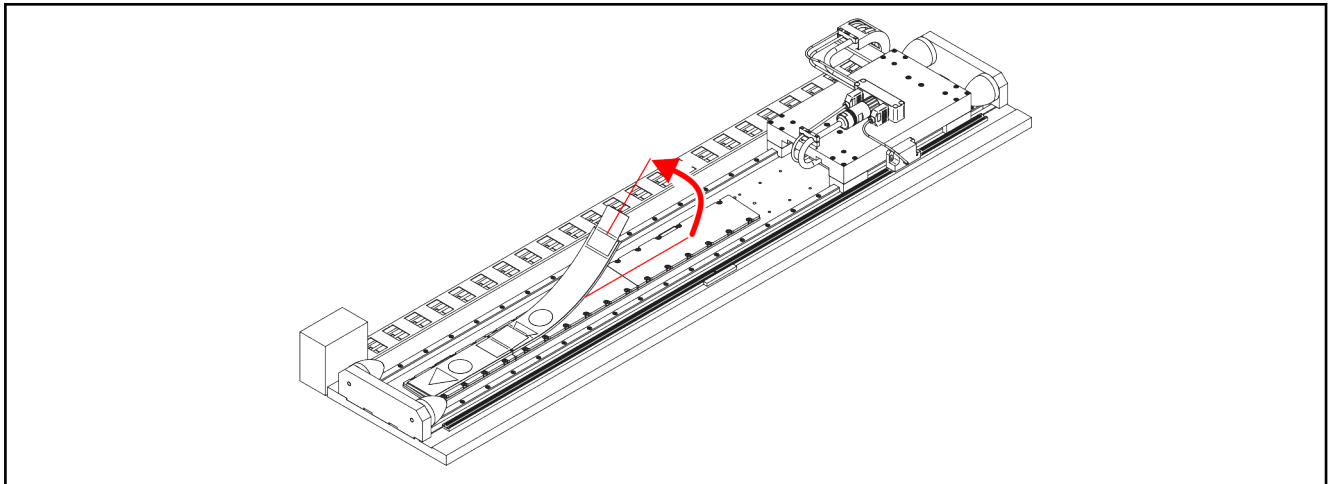

*Fig. 6-5:*

6. Position the slide with the primary part over the assembled secondary part and lock it against unintended movement.

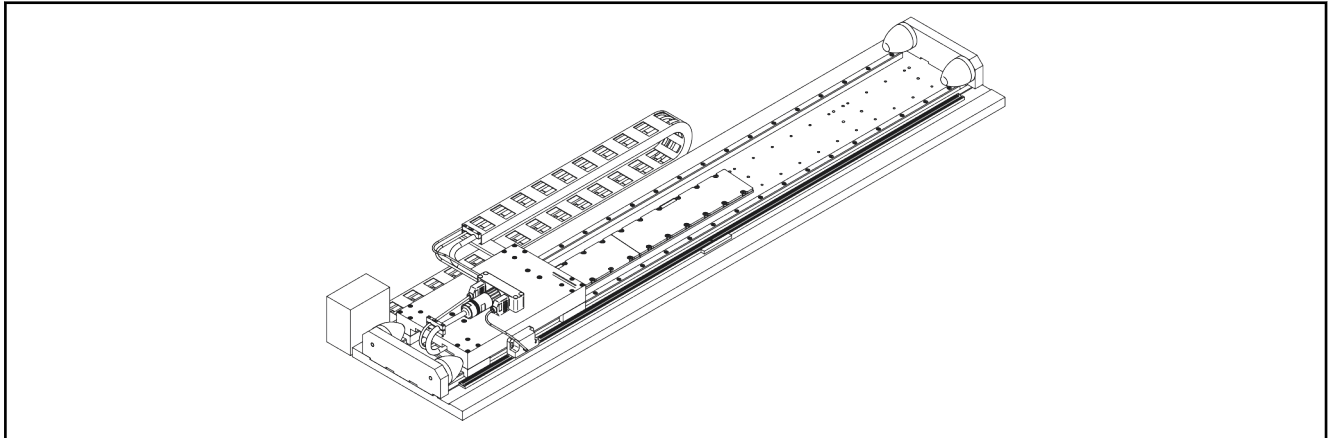

*Fig. 6-6:*

7. Assemble the remaining secondary parts according to working step 1 - 3.  
Afterwards, remove the transport and assembly protection.

## 6.5 Cover plate installation (option)

### 6.5.1 Notes

A stainless-steel cover plate can be installed at the ML3S for protection against dirt.



If cover plates are used, it must be ensured that the required air gap between the motor components is maintained. To achieve this, the installation height must be increased by the thickness of the cover plate. Please also observe the information provided in [Tab. 6-2](#).

Tools required for installation:

- Protective gloves for handling the cover strip

#### ⚠ CAUTION

The stainless-steel cover strip may have sharp edges.

Wear protective gloves when handling the cover plate.

- Cutter for cutting of the strip
- Measuring device for testing of the shielding

### 6.5.2 Installation

A cover plate can be installed after removal of the transport and assembly protection at the ML3S. Make sure that the entire length is clear. Due to the high magnetic attraction, the cover strip is firmly attached to the magnetic plates. To position the strip, unroll it. Respectively, roll it up to remove it.



Unrolling and rolling up of the strip should be performed by two persons.

1. If not already done, remove the transport and assembly protection from the ML3S.
2. Position the slide at one end of the axis to uncover the majority of the magnetic strip.
3. Unroll the strip over the free part of the magnetic strip.

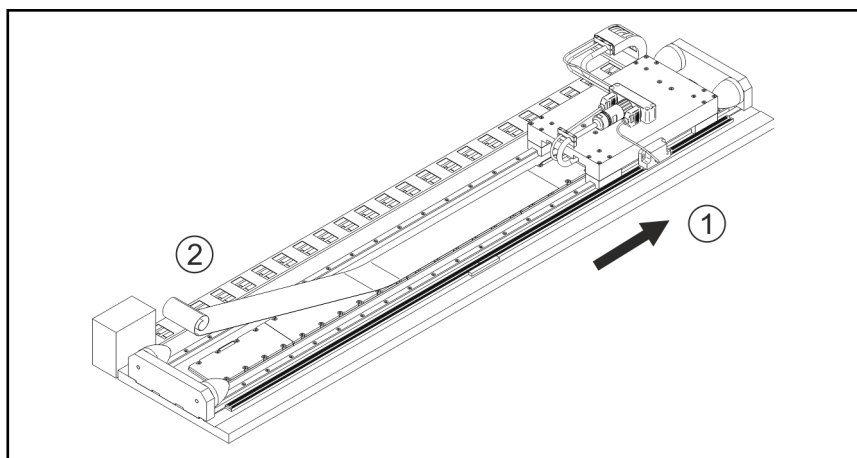

Fig. 6-7: Cover plate attachment at first side

4. Move the slide to the center of the axis

- Pull up the two ends of the cover strip in such a way that only a small section of the strip (under the slide) is in contact with the magnetic strip.

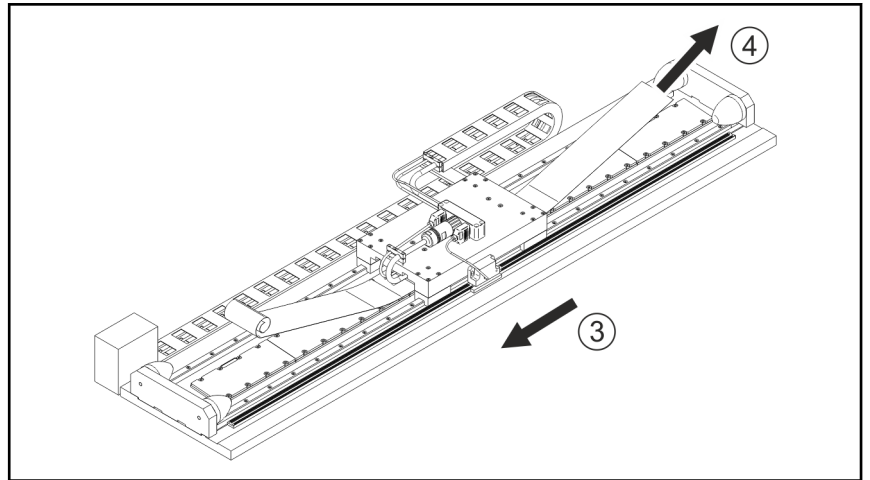

Fig. 6-8: Cover plate attachment at second side

- In this position, the cover strip can be moved over the magnetic strip. Position the strip in such a way that small sections protrude on both sides.

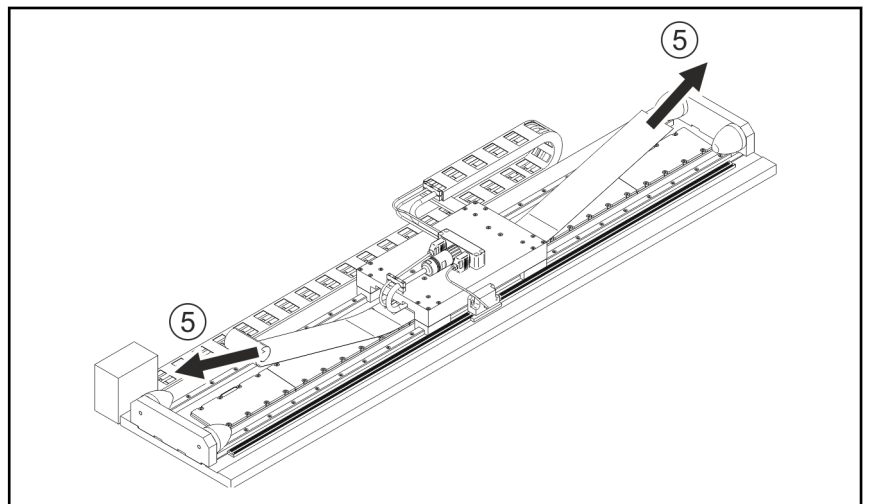

Fig. 6-9: Align cover plate on both sides



Make sure that the magnets are mounted at a slight angle. The cover strip must be cut off in this angle to ensure flush alignment with the end of the magnetic strip.

- Remove any excessive length and precisely align the strip. The cover strip should at least reach up to the end of the magnetic plates.



The magnetic strip does not serve as conductive grounding connection of the cover strip. Ensure grounding in accordance with the machine safety standard and check this before commissioning.

## 6.6 Hall unit installation (option)

### 6.6.1 Analog Hall unit

The preferred installation position of the Hall unit is at the slide at the front end of the primary part with the cable outlet (see Fig. 6-10). The Hall unit is aligned at the side of the coil unit. For further installation positions and information on commutation or calculation of parameter P-0-0508, refer to Tab. 1-2



For installation of the analog Hall unit at frame size MLP11, a spacer (see dimension "Z") is required between the Hall unit and the contact surface of the primary part.

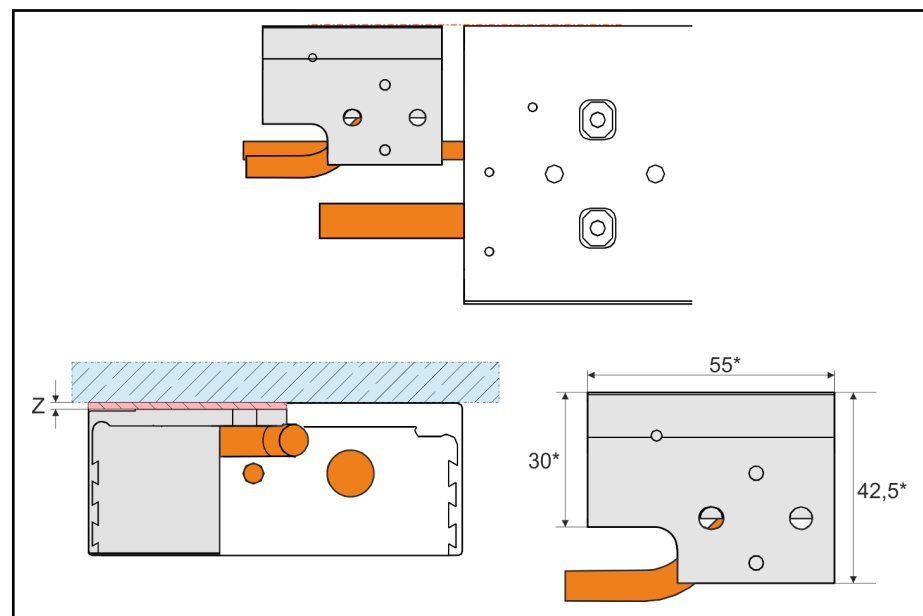

\* For tolerances refer to dimension sheet in ML3 project planning manual

Z Dimensions for spacer thickness

Fig. 6-10: Preferred installation position for the analog Hall unit

ML3P...	Spacer "Z"	Rotation to the motion axis [degrees]	Alignment to the side of the primary part	Screws	Tightening torque (+/- 10%)	Dowel pins
03	-	0.5	± 1 mm	M4	3.1 Nm	Ø 5 F8
06	-					
11	1					

Tab. 6-7: Installation requirements of analog Hall unit

## 6.6.2 Digital Hall unit

The preferred installation position of the Hall unit is at the slide at the front end of the primary part with the cable outlet (see Fig. 6-11). The Hall unit is aligned at the side of the coil unit. For further installation positions and information on commutation or calculation of parameter P-0-0509, see Tab. 1-2



For installation of the digital Hall unit, a spacer (see dimension "Z") is required between the Hall unit and the contact surface of the primary part.

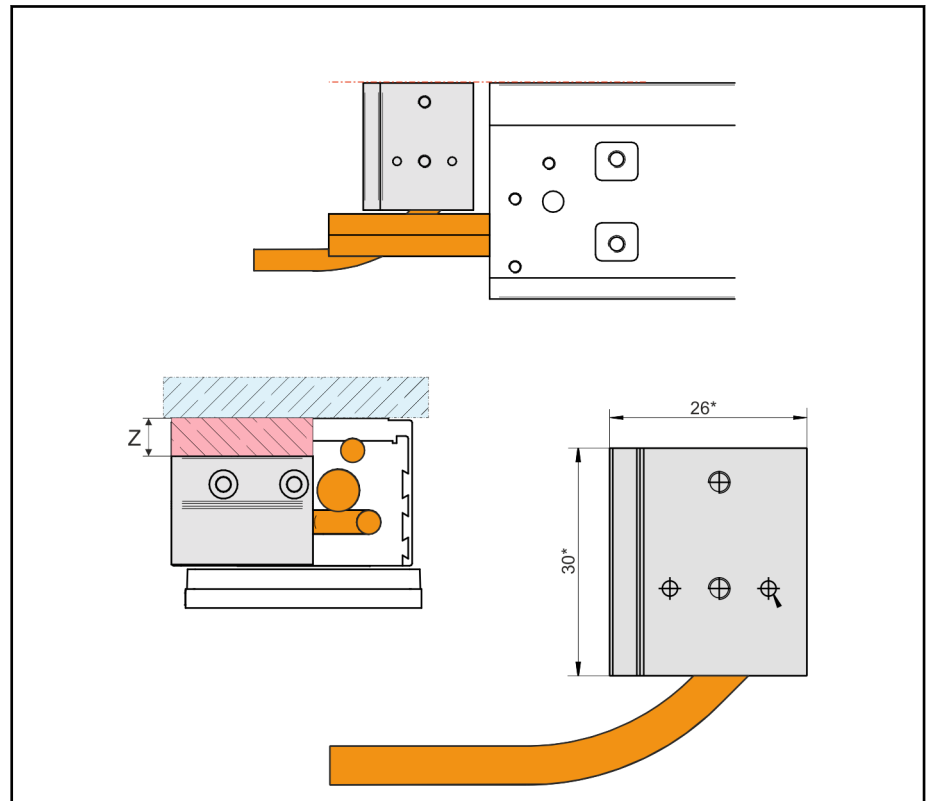

\* For tolerances refer to dimension sheet in ML3 project planning manual

Z Dimensions for spacer thickness

Fig. 6-11: Preferred installation position for the digital Hall unit

ML3P...	Distance dimension "Z"	Rotation to the motion axis [degrees]	Alignment to the side of the primary part	Screws	Tightening torque (+/- 10%)	Dowel pins
03	8.4 mm	0.5	± 1 mm	M3	1.3 Nm	Ø 5 F8
06	8.4 mm					
11	9.4 mm					

Tab. 6-8: Installation requirements of digital Hall unit

## 6.7 Electrical connection

### 6.7.1 Connection cable on primary part

The electrical connection of the primary part is done via two shielded connection cables, which are fixed with the primary part. These connection cables can be shorted according to the machine requirements and be prepared with a connector or a clamping point.

For connection of primary parts to the Rexroth controller, Rexroth offers a wide range of connectors and ready-made cables as accessories. All cables and connectors are perfectly fitted for the products and their requirements. For connection of the primary part with these extending cables, a connector has to be applied at the connection cables. Please note that self-assembled cables or cable systems of other manufactures may not comply with these requirements. Bosch Rexroth shall not be held responsible for resulting malfunctions or damages.



Ensure that the complete machine fulfills all necessary regulations, especially EN 60204.

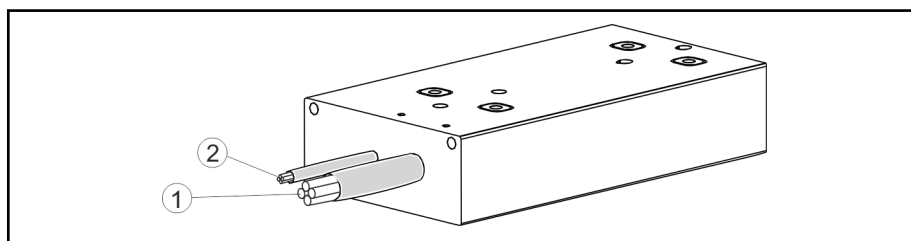

- ① Connection cable power  
② Connection cables temperature sensors

Fig. 6-12: Connection cable on primary part

#### ML3P connection cables

Connection cables	Cable lengths	Suitable for drag chains	ML3P03	ML3P06	ML3P11
Power	1 m	No	-	✓	✓
	3 m	yes	✓	-	-
Temperature	1 m	No	-	✓	✓
	3 m	No	✓	-	-

Tab. 6-9: ML3P connection cables

#### Wire designation of power connection cable

Power		Wire color / - designation
3-phase	L1	BK / 1
	L2	BK / 2
	L3	BK / 3
Grounding conductor	PE	GNYE
Shield		Metal braiding

Tab. 6-10: Wire designation of power connection cable

## Wire designation of temperature sensor connection cable

Temperature sensor	Wire color
PTC110-EK	WH
	BN
KTY83-122	GN
	YE
Shield	Metal braiding

Tab. 6-11: Wire designation of temperature sensor connection cable

## Connection cable characteristics

Connection cable power					
Primary part	Cross section [mm <sup>2</sup> ]	Cable diameter [mm]	Bending radius		Weight [kg/m]
			static [mm]	dynamic [mm]	
ML3P03	4 x 1.0	8.3	33.2	83	0.18
ML3P06-B... ML3P06-C... ML3P06-D... ML3P06-E... ML3P06-F... ML3P06-HNBKN	4 x 1.0	9.6	57.6	Not permitted	
ML3P06-HNBRN	4 x 2.5	11.4	68.4		Not permitted
ML3P11-D... ML3P11-E... ML3P11-F... ML3P11-H... ML3P11-L...					
Temperature connection cables					
ML3P03 ML3P06 ML3P11	4 x 0.14	4.3	25.8	Not permitted	0.033

Tab. 6-12: Connection cable characteristics



The power connection cable at the primary part is designed for a continuous current at standstill  $I_0$  for installation mode A. The cross-section of the extending power cable has to be selected according to the actual maximum effective current load. The cross sections of both cables may deviate.

## 6.7.2 Electrical connection primary part

Before connection of the primary parts, observe the information on suitability for drag chains of individual connection cables at the primary part in Fig. 6-9. Cables that are not suitable for drag chains must be routed in fixed installation (see Fig. 6-15) to a junction, e.g. device connector or terminal box. From

this junction, extending connection cables suitable for drag chains may be routed through the energy chain or the machine construction.

Connection via connector

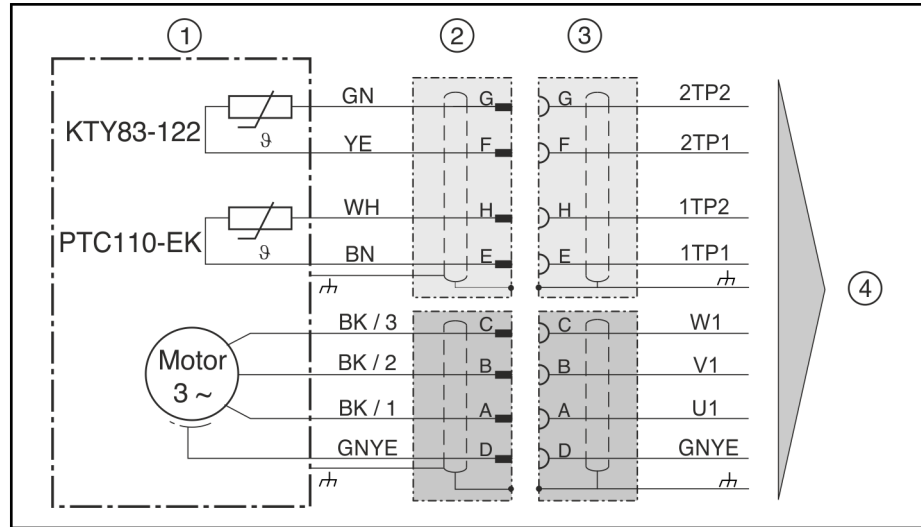

- ① ML3P primary part
- ② Device connector
- ③ Coupling
- ④ Controller

Fig. 6-13: Connection example connector

Connection via terminal box



If the primary part is to be connected to the controller by means of a terminal box, this terminal box has to be provided by the customer.

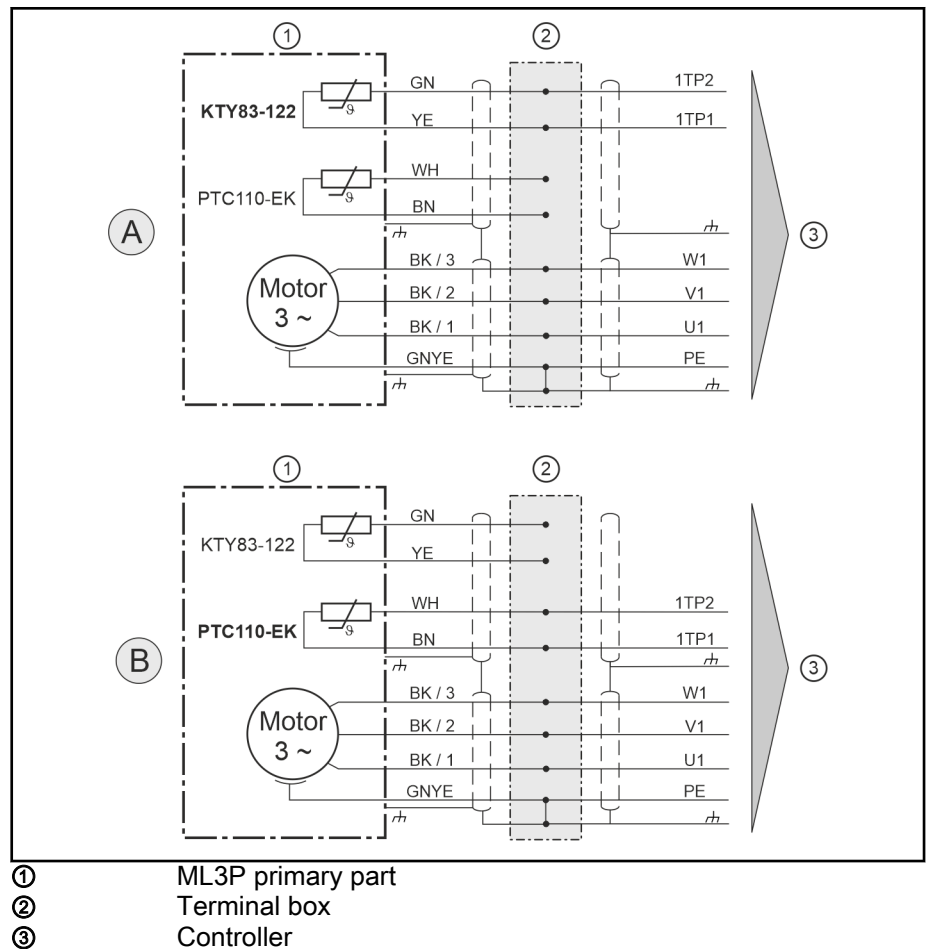

Fig. 6-14: Connection example terminal box

### 6.7.3 Routing of connection cables

#### NOTICE

Damage of the connection cables and the motor by dynamic bending loads!

The connection cables of the primary parts ML3P06 and ML3P11 and the temperature sensor cables of all ML3P may not be laid into drag chains. Installation in a cable carrier is only allowed for a cable lead after a junction suitable for energy or drag chains.

#### NOTICE

Avoid bending, pulling and pushing loads as well as continuous movements of the connection cable at the point where the cable exits from the primary part. Any load of this kind can lead to irreparable damage (e.g. cable break) on the primary part!

If a fixed installation is not possible, provide the connection cable with a strain relief (see Fig. 6-15) to protect the cable and the primary part from any damage (e.g. cable break).



If grounding of the secondary parts cannot be ensured due to installation in the customer-side machine construction, the ML3S are to be connected in compliance with DIN VDE 0100-410 to the potential of the protective conductor.

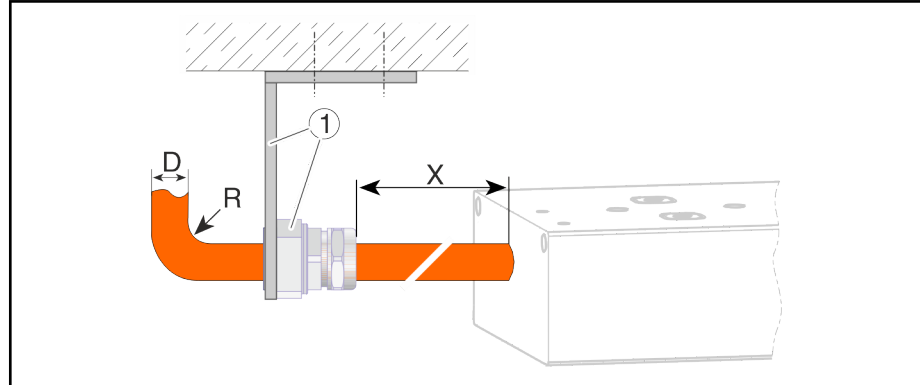

- Dimension "x"** Minimum distance 5 mm  
 ① Strain relief clamp (example) at MLP03 primary part  
 D Diameter of connection cable  
 R Allowed bending radius

Fig. 6-15: Example for strain relief of connection cable (only valid for ML3P03)

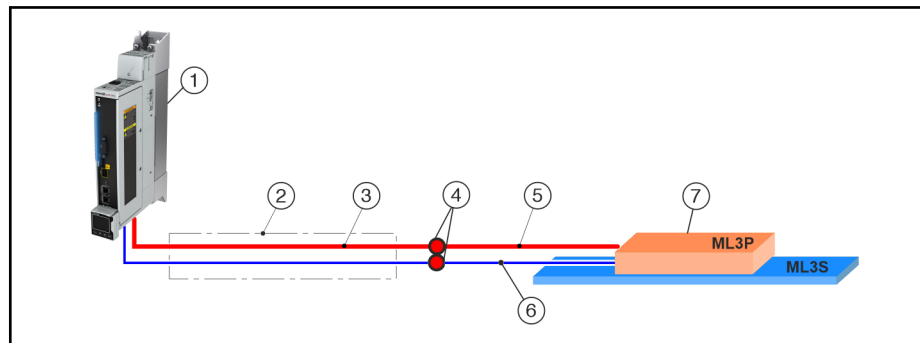

- ① Drive controller  
 ② Energy chain  
 ③ Power cables  
 ④ Junction (e.g. connector, terminal boxes)  
 ⑤ Connection cable (power)  
 ⑥ Connection cable (temperature)  
 ⑦ Motor ML3

Fig. 6-16: Routing connection cable of primary part

#### Parallel motor connection

When connecting a motor parallel on a drive controller, the following possibilities exist to assemble the motor cable.

- Installation of two separate parallel cables (Fig. 6-18)
- Installation of a collective cable with higher cross section (Fig. 6-19)

The first possibility offers the benefit of smaller bending radii. The whole cross section of parallel installed cables must be according to the increased cross section for parallel motor connections.

Power connection for single arrangement

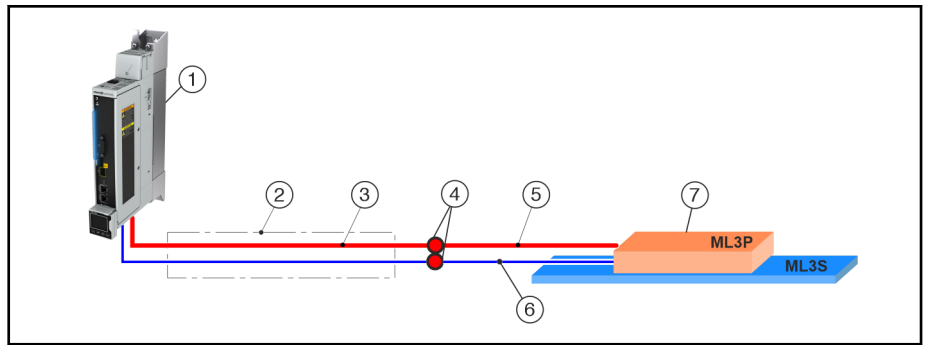

- ① Drive controller
- ② Energy chain
- ③ Power cables
- ④ Junction (e.g. connector, terminal boxes)
- ⑤ Connection cable (power)
- ⑥ Connection cable (temperature)
- ⑦ Motor ML3

Fig. 6-17: Power connection for single arrangement

Power connection for parallel arrangement, separate connection cable

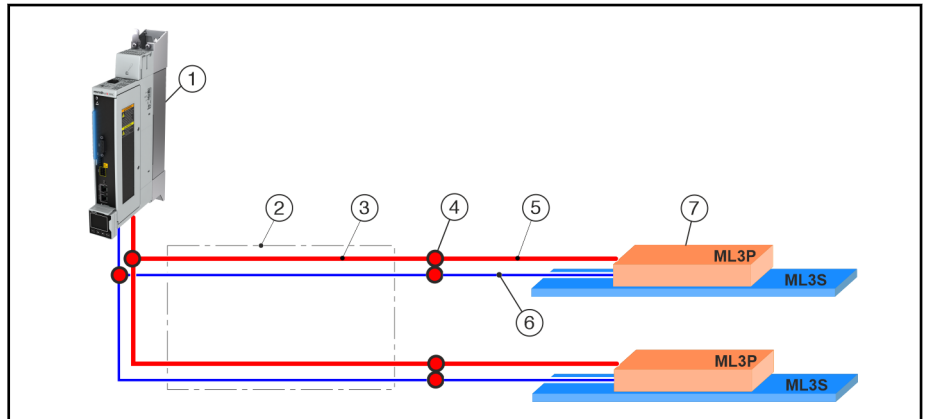

- ① Drive controller
- ② Energy chain
- ③ Power cables
- ④ Junction (e.g. connector, terminal boxes)
- ⑤ Connection cable (power)
- ⑥ Connection cable (temperature)
- ⑦ ML3P primary part

Fig. 6-18: Parallel arrangement, separate power cables

Power connection at parallel arrangement, collective power cable with higher cross section

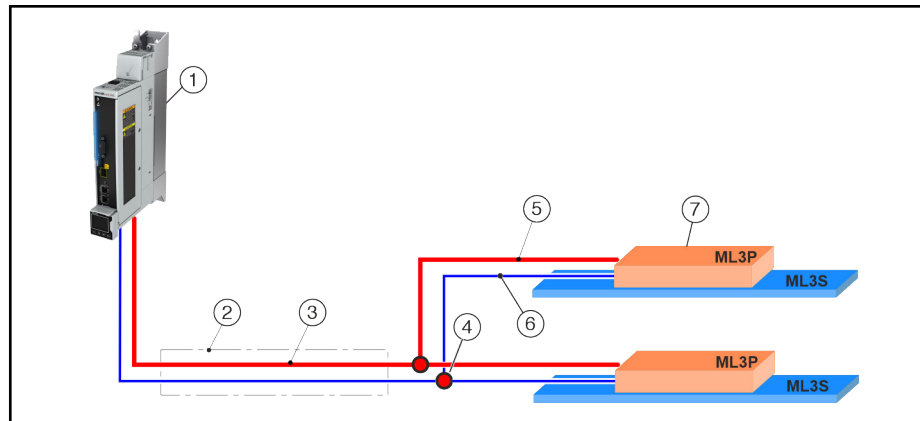

- ① Drive controller
- ② Energy chain
- ③ Power cables
- ④ Junction (e.g. connector, terminal boxes)
- ⑤ Connection cable (power)
- ⑥ Connection cable (temperature)
- ⑦ ML3P primary part

Fig. 6-19: Parallel arrangement, collective power cable



For ML3P03, the junction can also be positioned between drive controller and cable carrier.

### 6.7.4 Connection designations at Rexroth controllers

Single arrangement

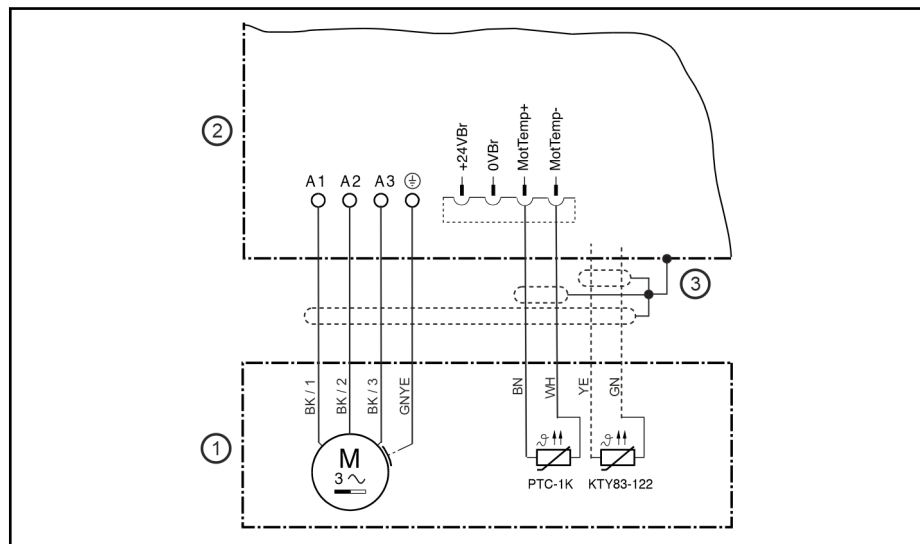

- ① ML3P primary part
- ② Rexroth - controller
- ③ Shield connection on the controller

Fig. 6-20: Connection on drive controller - single arrangement primary part

Parallel arrangement

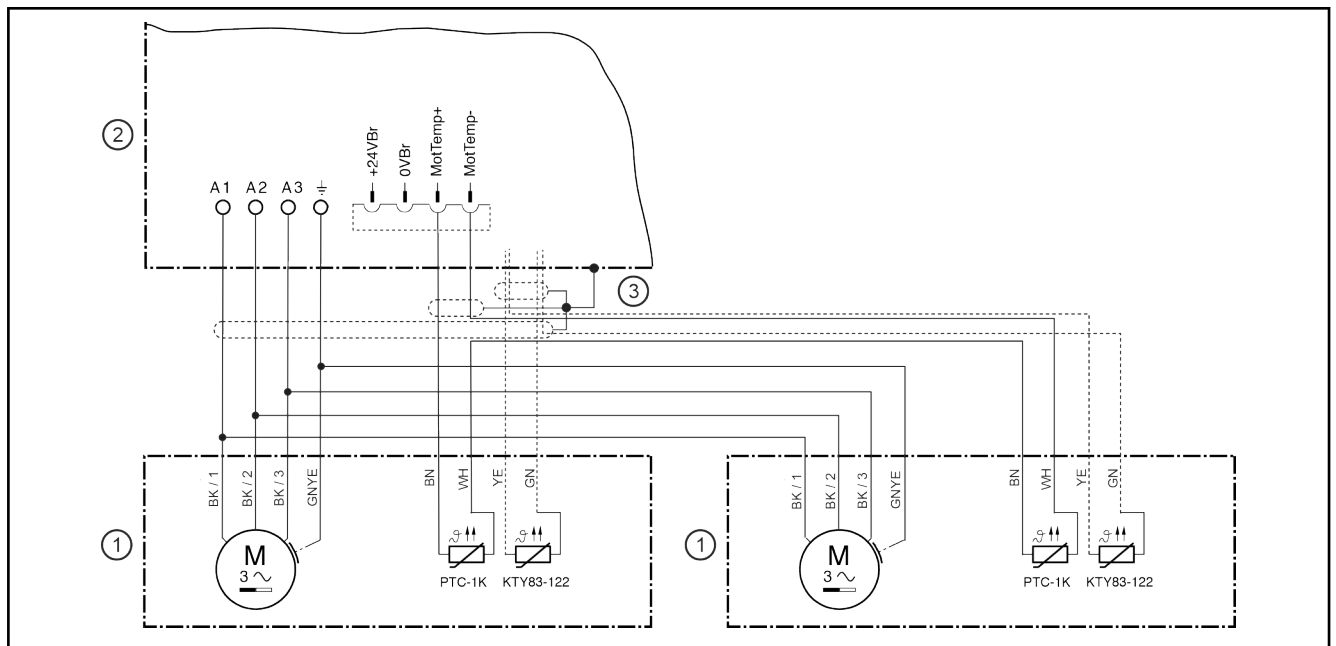

Fig. 6-21: Connection on drive controller - parallel arrangement primary part



For electrical connection of primary parts in parallel arrangement, refer to the project planning manual of the motors

## 6.7.5 Rexroth connection cable for ML3 motors



For connection of motors, Bosch Rexroth offers a wide range of connectors and ready-made cables as accessories. Please contact your Rexroth distributor.

## 6.7.6 Electrical connection of Hall unit (optional)

### Hall unit connection cable

The connection cable of the Hall unit is generally routed next to the connection cables of the primary part. After motor installation, the cable of the Hall unit can be shortened to the required length and be assembled with a D-sub connector, for example. Also refer to [chapter](#) .

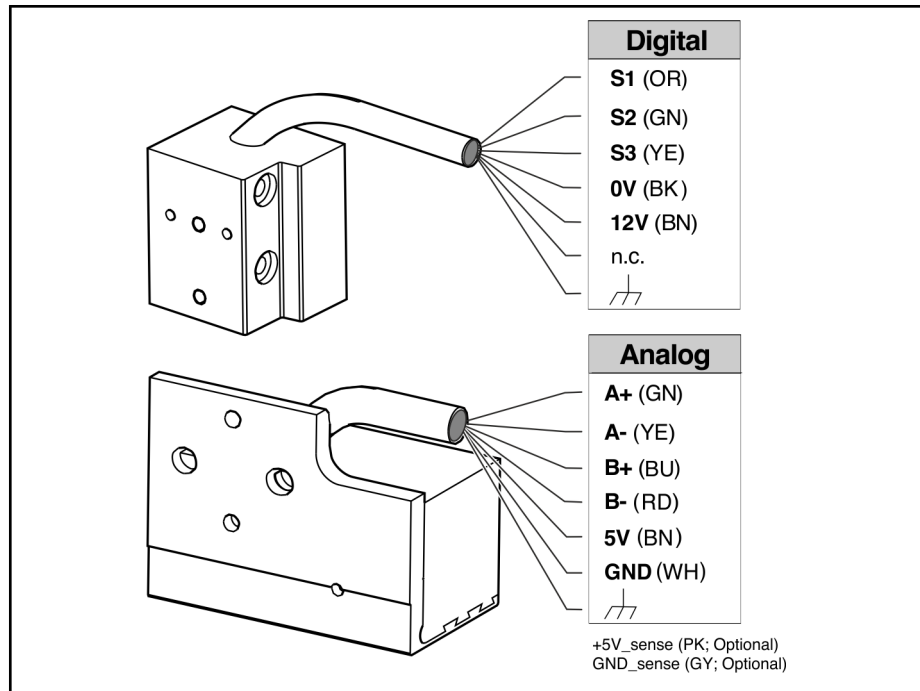

Fig. 6-22: Wire designation connection cable Hall unit

**Hall unit connection cable**

Hall unit	Diameter / Length	Control wire cross section [mm <sup>2</sup> ]	Allowed bending radius [R]*
Analog	6.2 mm / 3 m	4x 2x 0.14 mm <sup>2</sup>	6x D (37.2 mm)
Digital	5.0 mm / 1.2 m	6x 0.14 mm <sup>2</sup>	7.5x D (37.5 mm)

Tab. 6-13: Hall unit connection cable

**NOTICE** Avoid bending, pulling and pushing loads as well as continuous movements of the connection cable at the Hall unit. This type of loads can lead to irreparable damage (e.g. cable break)!

The connection cable of the Hall unit can be attached to the power cable by means of cable ties if the power cable is already equipped with strain relief. If a fixed installation is not possible, equip the connection cable of the Hall unit with strain relief (for example, see Fig. 6-15) to protect the cable and the primary part from any damage (e.g. cable break).

The Hall unit is a component that may be damaged by ESD. For this reason, the Hall unit is packed in an ESD protection bag on delivery. Before connecting the Hall unit, take appropriate measures for ESD protection (ESD = electrostatic discharge).

**Dimensioning of the Hall unit connection cable**

Before the Hall unit can be connected, the connection cable of the Hall unit must be equipped with a D-SUB connector with pins. The assignment of the connector depends on the type of the Hall unit (digitally or analogue)

PIN	Connection cable Hall unit	
	Analog (D-SUB 9-pin)	Digital (D-SUB 9-pin)
1	/	12 V (BN)
2	A+ (GN)	S1 (OR)
3	A- (YE)	/
4	0V (WH)	S2 (GN)
5	B+ (BU)	0V (BK)
6	B- (RD)	/
7	5V (BN)	/
8	/	S3 (YE)
9	/	/
Connector housing	Cable shield	Cable shield

Tab. 6-14: Connection assignment of D-SUB connector for Hall unit connection

## Digital Hall unit connection



Observe the information on the SHL03.1 adapter box in documentation DOK-INDRV\*-HCS01\*\*\*\*\*-PRxx-xx-P, MNR R911322210.

For connection of a digital Hall unit in combination with an incremental length measuring system to a Rexroth controller, the **SHL03.1 adapter box** has to be used.

The SHL03.1 brings both incoming signal cables of Hall unit and length measuring system together and redirects their signals via a single connection cable to the drive controller for encoder evaluation.

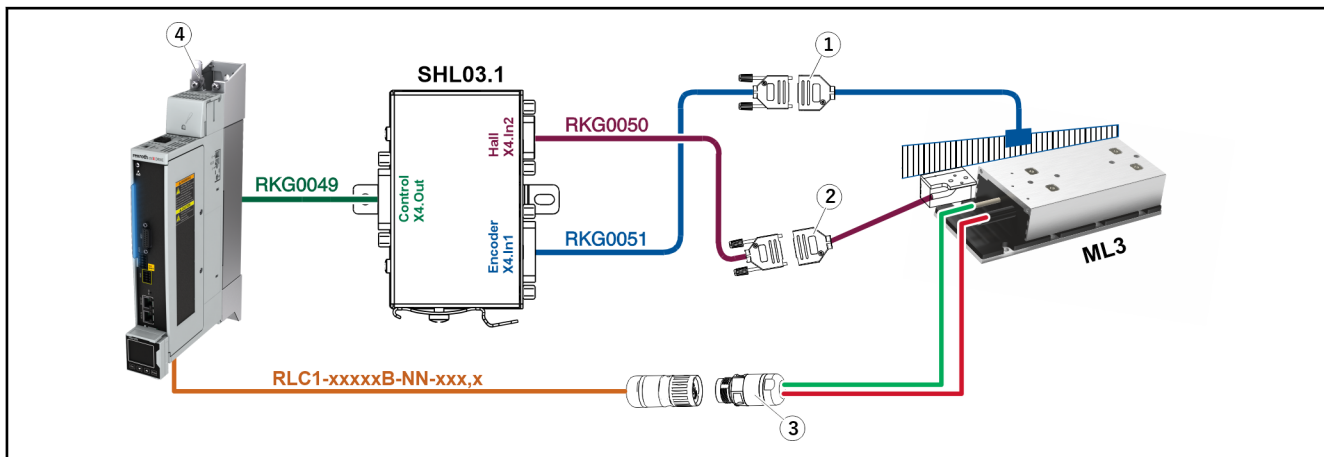

- ① Device connector RGS0005 (D-SUB connector, 9-pin)
- ② Device connector RGS0005 (D-SUB connector, 9-pin)
- ③ Power and temperature connection points
- RKG0049** Adapter box ↔ encoder evaluation on drive controller
- RKG0050** Digital Hall unit ↔ adapter box (max. cable length 30 m)
- RKG0051** Length measuring system ↔ Adapter box

Fig. 6-23:

Connection overview of ML3P with digital Hall unit

## Analog Hall unit connection

To connect an absolute measuring system and an analog Hall unit, a shelf with 2 encoder interfaces in the Rexroth controller is required.

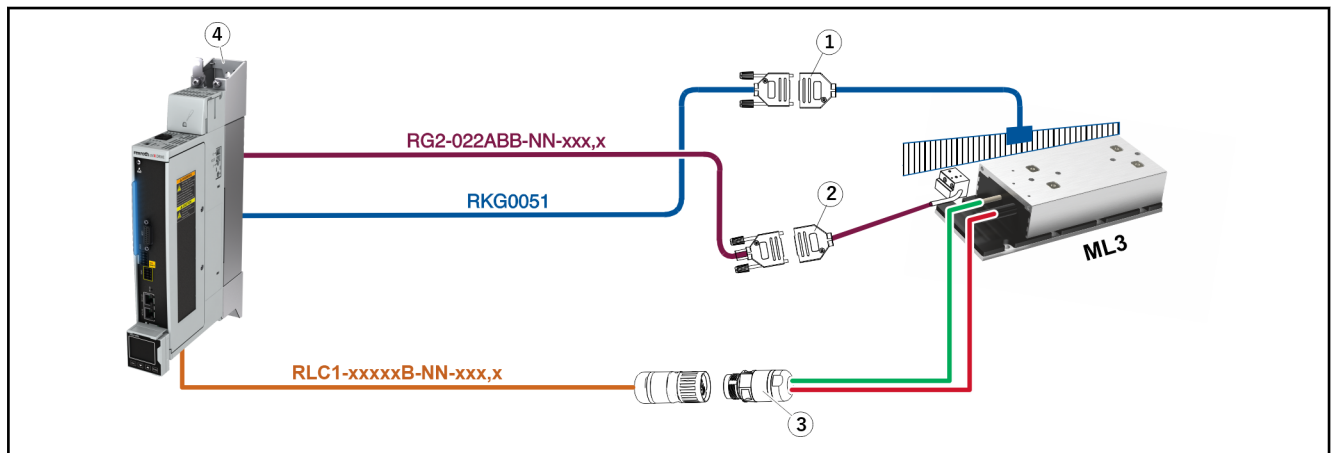

- ① Device connector RGS0005 (D-SUB connector, 9-pin)
- ② Device connector RGS0005 (D-SUB connector, 9-pin)
- ③ Power and temperature connection points
- RG2-022ABB...** Analog Hall unit ↔ Encoder evaluation at drive controller
- RKG0051** Length measuring system ↔ Encoder evaluation at drive controller

Fig. 6-24: Connection overview of ML3P with analog Hall unit



## 7 Commissioning and operation

### 7.1 Safety

#### WARNING

High electric voltage! Danger to life, risk of injury by electric shock.



Life parts are dangerous.

- ▶ Do not open any covers or flange sockets during operation.
- ▶ Do not connect or disconnect plug-connectors and connection clamps.

#### WARNING

Risk of injuries due to moving machine parts!



▶ Do not remove covers, machine parts or protective devices during operation.

▶ Do not enter the motion area of the machine. Prevent personnel from accidentally entering the machine's range of motion by using, for example:

- Safety fences, safety screens or protective covers.
- Optical sensors

#### CAUTION

Thermal danger due to hot surfaces with temperatures over 60 °C during operation



▶ Do not touch hot motor surfaces.

▶ Install protection against contact, if necessary.

▶ Make sure that no temperature-sensitive components (cables, electronic components, ...) touch hot surfaces.

### 7.2 Commissioning



The motor can be operated only after installation into a machine. For start up, please observe the documentation of all system components. A detailed description of the motor commissioning on Rexroth controllers is described in the project planning manual  Self-cooled linear motors ML3 (see [Tab. 1-2 "Additional documentation"](#)).

Prior to commissioning, ensure that the following requirements are met.

- Make sure that the motor is mechanically and electrically connected correctly.
- Ensure that the motor and all participating components of the drive are undamaged (e.g. length measuring system).
- Make sure that the axis can freely move over the whole traverse path.
- Please observe the general safety instructions on the protection against hazardous movements.

## 7.3 Operation

During operation, keep the ambient and operation conditions and technical data specified in the project planning manual .

### Checks during operation:

- ▶ Pay attention to exceptional noise.
- ▶ Pay attention to increased vibrations.
- ▶ Check the motor for cleanliness.
- ▶ Check the monitoring devices and diagnostic / error messages of the controllers.



Immediately decommission the drive when deviations from normal operation exist. For further procedure refer to [Chapter Troubleshooting](#).

---

## 8 Maintenance and repair

### 8.1 Cleaning and servicing

#### WARNING

**Danger! Electric voltage! Operations in the vicinity of live parts are extremely dangerous.**



Any work required on the electric system may be carried out only by skilled electricians. Tools for electricians (VDE tools) are absolutely necessary.

*Prior to commencing work:*

1. Isolate (even auxiliary circuits).
2. Secure against reactivation.
3. Ensure de-energization.
4. Ground and short-circuit.
5. Cover or shield any adjacent live parts.

#### WARNING

**Personal and material damage during maintenance work in operation!**



- ▶ Never do any maintenance work on life machines.
- ▶ While carrying out maintenance work, secure the machine such that it cannot restart or be used by unauthorized persons.

#### CAUTION

**Hot surfaces with temperatures over 60 °C may cause burns!**



- ▶ Before you work in the machine, let the motor cool down.
- ▶ Wear safety gloves.
- ▶ Do not work on hot surfaces.

#### Motors

Excessive dirt, dust or chips may adversely affect the functionality of the motors and, in extreme cases, even cause a failure of the motors. Clean the motors at regular intervals (after one year at the latest) to reach a sufficiently high heat emission surface. If the cooling fins, for example, are partially covered with dirt, sufficient heat dissipation via the ambient air is no longer ensured.

#### Connection cable

#### WARNING

**Death by electrocution possible due to live parts!**



- ▶ Immediately put the machine out of operation and replace defective connection cables.
- ▶ Never do any provisional repairs on the connection cables.

- Check in regular distances the connection cables on damage and replace them if necessary.
- Check optionally existing drag chains on defects.

- Check the protective conductor connection for proper condition and firm seating at regular intervals. Replace it, if necessary.

## 8.2 Service repair, maintenance and spare parts

Increase availability with regular preventive maintenance measures. Observe the machine manufacturer's instructions in the machine maintenance plan and the maintenance measures described below.

The following points should be observed and if necessary restored during the preventive check of motor and auxiliary components:

- Noticeable sound during operation
- Scratches on primary and secondary part
- State of power and encoder cables in a drag chain.
- State of linear scale (e.g. soiled)
- State of guides (e.g. deterioration of linear guides)

Measure	Interval
Check the mechanical and electrical connections.	According to the specifications in the machine maintenance plan, but at least every 1000 operating hours.
Check the machine for smooth running, vibrations and bearing noise.	According to the specifications in the machine maintenance plan, but at least every 1000 operating hours.

Tab. 8-1: Maintenance measures



Generally, keep the motor installation room clean to prevent that dirt (e.g. shavings, swarfs, grease by guides, etc.) reaches the air gap between primary and secondary part

Our worldwide service network provides an optimized and efficient support. Our experts offer you advice and assistance should you have any queries. You can contact us **24/7**.

### Service Germany

Our technology-oriented Competence Center in Lohr, Germany, is responsible for all your service-related queries for electric drives and controls.

Contact the **Service Helpdesk & Hotline** under:

Phone: **+49 9352 40 5060**  
 Fax: **+49 9352 18 4941**  
 Email: [service.svc@boschrexroth.de](mailto:service.svc@boschrexroth.de)  
 Internet: <http://www.boschrexroth.com>

Additional information on service, repair (e.g. delivery addresses) and training can be found on our internet sites.

### Service worldwide

Outside Germany, please contact your local service office first. For hotline numbers refer to the sales office addresses on the Internet.

### Preparing information

For quick and efficient help, please have the following information ready:

- Detailed description of the fault and the circumstances
- Information on the rating plate of the products in question, particularly type codes and serial numbers

- Your contact data (phone number, fax number, e-mail address)



## 9 Disassembly

### DANGER

**Fatal injury due to errors during the activation of motors or work on moving elements!**

- ⇒ Work on machines is only allowed if they are secured and while they are not running.
- ⇒ Before starting disassembly, secure the machine against unforeseeable movements and against unauthorized operation.
- ⇒ Before dismantling the motor and the supply lines, secure them against dropping or moving and disconnect the mechanical connections only thereafter.

### WARNING

**High electric voltage! Danger to life, risk of injury by electric shock.**



Life parts are dangerous.

- ▶ Do not open any covers or flange sockets during operation.
- ▶ Do not connect or disconnect plug-connectors and connection clamps.

### WARNING

**Danger due to permanent magnets!**



▶ Health hazard for persons with heart pacemakers, metallic implants and hearing aids in direct environment of permanent magnets.



▶ Crushing hazard of fingers and hand due to heavy attractive forces of the magnets.



▶ Risk of destruction of sensitive parts such as watches, credit cards, ...

Please note the safety instructions [Chapter 2.6.3](#) and [Chapter 2.6.4](#) .



The machine manufacturer must observe the special features of the construction and create a special disassembly instruction for the motor components. Only this disassembly instruction of the machine manufacturer is binding.

1. Observe the disassembly instruction of the machine manufacturer.
2. Use the machine-side control command to decelerate the drive to a controlled standstill.
3. Switch off the power and control voltage of the controller.
4. Switch off the main switch of the machine and deactivate external systems according to the instructions of the manufacturer.
5. Secure the machine against accidental movements and against unauthorized operation.
6. Wait until the discharge time of the electrical systems has elapsed and then disconnect all electrical connections. Lock electric cables and contacts against contact with other electrical parts.

7. Remove dirt, chips and other any kind of residues from the motor.
8. Before dismounting the motor and the supply lines, secure them against dropping or moving and disconnect the mechanical connections only thereafter.
9. Right after disassembly, store or transport the motor components, especially the secondary part in its origin package. Please observe the safety notes when handling the secondary part. Please also observe the information provided in [chapter 5 "Transport and storage" on page 13](#).
10. If necessary, record all measures in the commissioning log or machine maintenance plan.

## 10 Environmental protection and disposal

Disposal of the motor components can be done according to the applicable legal process in normal recycling process.

### Recycling

Most of the products can be recycled due to their high content of metal. In order to recycle the metal in the best possible way, the products must be disassembled into individual assemblies. Metals contained in electric and electronic assemblies can also be recycled by means of special separation processes.

### Significant motor components

Basically, our motors consist of the following components:

- Steel, aluminum, copper, brass
- Plastic parts, insulation and composite material
- Electronic components
- Permanent magnets

Plastic parts of the products may contain flame retardants. These plastic parts are labeled according to EN ISO 1043. They have to be recycled separately or disposed of according to the applicable legal provisions.

### WARNING

### Danger due to permanent magnets!



▶ Health hazard for persons with heart pacemakers, metallic implants and hearing aids in direct environment of permanent magnets.



▶ Crushing hazard of fingers and hand due to heavy attractive forces of the magnets.



▶ Risk of destruction of sensitive parts such as watches, credit cards, ...

Please note the safety instructions [Chapter 2.6.3](#) and [Chapter 2.6.4](#).



The permanent magnets of the secondary part must be demagnetized before disposal to avoid injuries or damage.

### Demagnetize magnets

The demagnetization of the permanent magnets of the secondary part is reached via special thermal treatment. The handling duration is influenced by the frame of the motor component. The secondary part has to remain in the oven for a minimum of 30 minutes, starting at the time, the magnetic surface has reached 300 °C.



After cooling down of the secondary part and successful demagnetization, the magnets can be effortlessly disconnected from the mounting plate.

### Packaging

Our packaging materials do not contain any problematic materials and can therefore be easily disposed. Packaging materials are: Wood, carton and styrofoam

### Batteries and accumulators

Batteries and accumulators can be labeled with this symbol.



The symbol indicating "separate collection" for all batteries and accumulators is the crossed-out wheeled bin.

End users in the EU are legally bound to return used batteries. Outside the validity of the EU Directive 2006/66/EC, the particularly applicable regulations must be followed.

Used batteries can contain hazardous substances which can harm the environment or people's health when improperly stored or disposed of.

After use, the batteries or accumulators contained in Rexroth products must be properly disposed of according to the country-specific collection systems.

#### **Disposal by the manufacturer**

Our products can be returned to us for disposal. However, this requires that the products be free from oil, grease or other dirt.

The motor components must be returned in a suitable packaging (origin package if possible). In the case of a transport by air freight, please observe the dangerous goods regulations (IATA) for the secondary part.

Deliver the products "free domicile" to the following address:

Bosch Rexroth AG  
Electric Drives and Controls  
Buergermeister-Dr.-Nebel-Straße 2  
97816 Lohr am Main, Germany

# 11 Troubleshooting

## 11.1 Procedure

Possible causes for failures of motors can be restricted to the following areas:

- Motor cooling and temperature behavior
- Internal temperature sensor
- Mechanical damage of the motor
- Mechanical connection to machine

The lengths measuring system and the temperature sensor are monitored by the controller or the control unit; corresponding diagnostic messages are displayed. Observe the instructions in the corresponding documentation.

The sections below describe examples of some fault states along with possible causes. This list is not exhaustive.

Malfunctions	Failure cause	Measures
Motor does not run	Controller enable signal missing	Activate controller enable signal
	Controller fault	Troubleshoot acc. to documentation of controller
	Voltage supply missing	Control voltage supply
Vibrations	Mounting screws loose	Lock screw connections acc. to specifications
Running noise	Foreign bodies within the motor	Stop the motor --> repair by manufacturer
	Guides defective	Stop the motor --> repair by manufacturer
High motor temperatures Motor temperature monitoring is activated	Operation outside of rated data	Reduce load and check the dimensioning
Wrong or defective temperature display	Temperature sensor not connected	Connect temperature sensor
	Temperature sensor defective	Stop the motor --> repair by manufacturer

Tab. 11-1: Malfunctions on ML3 motors



In the case of malfunctions or troubleshooting, please observe the notes in the project planning manual, too. Contact the manufacturer, if necessary.



# 12 Declaration of conformity



## EU-Konformitätserklärung - Original

Dok.-Nr.: DCTC-30336-001

Datum: 2018-03-13

- nach Maschinenrichtlinie 2006/42/EG
- nach Niederspannungsrichtlinie 2014/35/EU
- nach EMV-Richtlinie 2014/30/EU
- nach ATEX-Richtlinie 2014/34/EU

Hersteller:  
 Bosch Rexroth AG  
 Bürgermeister-Dr.-Nebel-Straße 2  
 97816 Lohr am Main / Germany,

Die alleinige Verantwortung für die Ausstellung dieser Konformitätserklärung trägt der Hersteller.

Wir erklären, dass die nachstehenden Produkte

Bezeichnung: 3-PHASE SYNCHRONOUS MOTOR

Baureihen: ML3...03... (Primärteil ML3P03..., Sekundärteil ML3S03...)  
 ML3...06... (Primärteil ML3P06..., Sekundärteil ML3S06...)  
 ML3...11... (Primärteil ML3P11..., Sekundärteil ML3S11...)

ab Herstellungsdatum: 2018-03-13

in Übereinstimmung mit den oben genannten EU-Richtlinien entwickelt, konstruiert und gefertigt wurden.

Angewandte harmonisierte Normen:

Norm	Titel	Ausgabe
EN 60034-1 (IEC 60034-1)	Drehende elektrische Maschinen – Teil 1: Bemessung und Betriebsverhalten	2010 + Cor.:2010 (2010, modifiziert)
EN 60034-5 (IEC 60034-5)	Drehende elektrische Maschinen – Teil 5: Schutzarten aufgrund der Gesamtkonstruktion von drehenden elektrischen Maschinen (IP-Code) –Einteilung	2001 + A1:2007 (2000 + Corrigendum 2001 + A1:2006)

© Bosch Rexroth AG 2018

DCTC-30336-001\_KOE\_N\_DE\_2018-03-13.docx

Lohr am Main , den 2018-03-13 i.V. Volker Schlotz ppa. Ralf Koeppe  
 Ort Datum Volker Schlotz Dr. Ralf Koeppe  
 Leitung Markt- und Chief Technical Officer  
 Produktmanagement Automatisierungs- und  
 Antriebssysteme Elektrifizierungslösungen

Änderungen im Inhalt der EU-Konformitätserklärung sind vorbehalten. Derzeit gültige Ausgabe auf Anfrage.

Fig. 12-1: CE declaration of conformity

Declaration of conformity



**EU declaration of conformity - original**

Doc. No.: DCTC-30336-001

Date: 2018-03-13

- in accordance with Machinery Directive 2006/42/EC
- in accordance with Low Voltage Directive 2014/35/EU
- in accordance with EMC Directive 2014/30/EU
- in accordance with ATEX Directive 2014/34/EU

Manufacturer:  
 Bosch Rexroth AG  
 Bürgermeister-Dr.-Nebel-Straße 2  
 97816 Lohr am Main / Germany

This declaration of conformity is issued under the sole responsibility of the manufacturer.

We hereby declare that the products below

Name: 3-PHASE SYNCHRONOUS MOTOR

Series: ML3...03... (primary part ML3P03..., secondary part ML3S03...)  
 ML3...06... (primary part ML3P06..., secondary part ML3S06...)  
 ML3...11... (primary part ML3P11..., secondary part ML3S11...)

from the date of manufacture: 2018-03-13

were developed, designed and manufactured in compliance with the above-mentioned EU directives.

Harmonized Standards applied:

Standard	Title	Edition
EN 60034-1 (IEC 60034-1)	Rotating electrical machines – Part 1: Rating and performance	2010 + Cor.:2010 (2010, modified)
EN 60034-5 (IEC 60034-5)	Rotating electrical machines – Part 5: Degrees of protection provided by integral design of rotating electrical machines (IP code) - Classification	2001 + A1:2007 (2000 + Corrigendum 2001 + A1:2006)

Lohr am Main , dated 2018-03-13 i.v. Volker Schlotz ppa. Ralf Koeppe  
 Place Date Head of Market and Product Chief Technical Officer  
 Management Drive Systems Automation and Electrification Solutions

We reserve the right to make changes to the content of the EU Declaration of Conformity. Current issue on request.

Fig. 12-2: Translated CE declaration of conformity

© Bosch Rexroth AG 2018

DCTC-30336-001\_KOE\_N\_EN\_2018-03-13.docx

# Index

## A

Accumulators.....	49
Additional documentation.....	1
Air gap.....	16, 17, 24
Ambient temperature (operation).....	11
Assembly	
Primary parts .....	18
Secondary parts.....	20

## B

Batteries.....	49
----------------	----

## C

Commissioning.....	41
Connection	
Analog Hall unit.....	39
Digital Hall unit.....	38
Connection assignment	
Connection cable Hall unit.....	36
Connection cable	
Cable break.....	31, 36
Fixed installation.....	31, 36
Hall unit.....	35
Power.....	28
Temperature.....	29
Connection cable Hall unit.....	36
Allowed bending radius.....	36
Connection cables.....	28, 43
Characteristics.....	29
Contained substances	
see significant motor components.....	49

## D

Degree of protection.....	11
Dimensioning	
Hall unit connection cable.....	36
Disassembly.....	47
Discharge time.....	47
Disposal.....	49
Permanent magnets.....	49
Dowels	
Primary part.....	18
Secondary part.....	21
Drag chains.....	43

## E

Electrical connection	
Cable routing.....	31
Connection designations.....	34
Hall unit.....	35
Primary part.....	29
Rexroth connection cable.....	35
Environmental protection.....	49
ESD.....	36
ESD protection.....	36

## F

Failure cause	
Measures.....	51
Fastening screws	
Primary part.....	18
Secondary part.....	20
Fault states.....	51

## G

Grounding.....	32
----------------	----

## H

Hall unit.....	35
Hall unit connection cable	
Control wire cross section.....	36
Diameter.....	36
Length.....	36
Heat dissipation.....	43

## I

IATA 953.....	13
Improper use	
Improper use.....	4
Indented use	
Directives.....	3
Standards.....	3
Installation dimensions.....	15
Installation height	
Installation height with cover plate.....	17
Installation height without cover plate.....	17
Installation height (without cover plate).....	16
Insulation class.....	11
Intended use.....	3

## M

Maintenance measures.....	44
Motor design.....	11

## O

Operation.....	42
----------------	----

## P

Packaging.....	49
Parallelism.....	15
Permanent magnets.....	6
Protective conductor.....	32

## Q

Qualified personnel.....	4
--------------------------	---

## R

Reference marks on the secondary part.....	22
Return of products.....	50

## Index

**S**

Safety notes.....	4
Scope of delivery.....	9
ML3P.....	9
ML3S.....	9
Screw lock.....	15
Service Helpdesk & Hotline.....	44
SHL03.1.....	38
SHL03.1 adapter box.....	38
Significant motor components.....	49
Skilled personnel.....	15
Sound pressure level.....	11
Spare parts.....	44
Storage conditions.....	14
Storage time.....	14
Strain relief.....	32
Symmetry.....	15

**T**

Technical features.....	11
Tightening row.....	19
Tolerances	
Air gap.....	17
Levelness.....	16
Parallelism.....	16
Transport	
Air freight.....	13
external.....	13
internal.....	13
Transport and installation protection.....	22

**U**

Unintended use.....	3
---------------------	---

**W**

Wire designation	
Power.....	28
Temperature.....	29

# Notes

**Bosch Rexroth AG**

P.O. Box 13 57

97803 Lohr a.Main, Germany

Bgm.-Dr.-Nebel-Str. 2

97816 Lohr a.Main, Germany

Phone +49 9352 18 0

Fax +49 9352 18 8400

[www.boschrexroth.com/electrics](http://www.boschrexroth.com/electrics)



R911389762