

Counter balance valve Häggglunds VCBCA 480

RE 15378
Edition: 12.2015
Replace: New

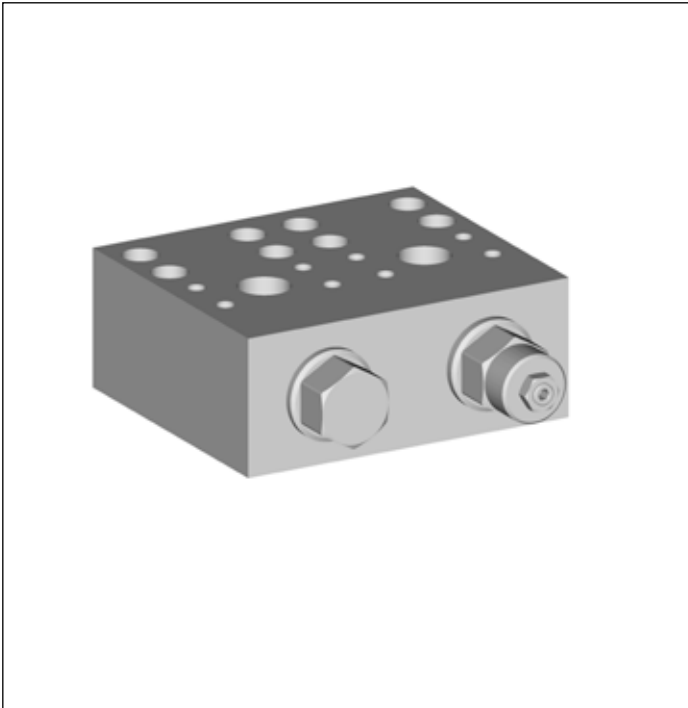

- ▶ Valid for: Häggglunds motors CA, CB
- ▶ Maximum flow 480 l/min (127 gpm)
- ▶ Maximum pressure 350 bar (5076 psi)

Features

- ▶ Compact and robust design
- ▶ Mounted directly on Häggglunds motors
- ▶ Counter balance function with low pilot pressure
- ▶ Pilot pressure independent of load pressure

Contents

1	Preface	2
2	Ordering code	3
3	Functional description	4
4	Technical data	6
5	Pressure loss diagram	7
6	Dimensions / Interface	8
7	Installation	9
8	Required and additional documents	12



1 Preface

Warning signs

In this manual you will find the following signs which indicate a potential hazard, which can or will cause personal injury or substantial property damage. Depending on the probability of the hazard, and how serious the injury or property damage could be, there are three levels of classification.

Warning sign (warning triangle):	Draws attention to the hazard
Signal word:	Identifies the degree of hazard
Type of risk:	Specifies the type or source of the hazard
Consequences:	Describes the consequences of non-compliance
Precautions:	Specifies how the hazard can be prevented

The signal words have the following meaning:

Warning sign, signal word	Meaning
 DANGER	Indicates a dangerous situation which will cause death or severe personal injuries if not avoided.
 WARNING	Indicates a dangerous situation which may cause death or severe personal injuries if not avoided.
 CAUTION	Indicates a dangerous situation which may cause minor or medium personal injuries if not avoided.
NOTICE	Material damage: the product or its environment could be damaged.

2 Ordering code

In order to identify Hägglunds equipment exactly, the following ordering code is used. These ordering codes should be stated in full in all correspondence e.g. when ordering spare parts.

Example: Valve VCBCA 480:

VCBC	A	480	00	00	B
01	02	03	04	05	06

01	Counter balance valve	VCBC
02	Version	A
03	Maximum flow (l/min)	480
04	Modification *)	00
05	Design	00
	Standard	00
	Special index *)	01-99
06	Configurations	
	Counter balance function in P and C lines, with pilot pressure from opposite line or external Cx and Px	A
	Counter balance function in P motor line, with pilot pressure from opposite line or external Cx	B
	Counter balance function in P motor line, with pilot pressure from opposite line	C
	Counter balance function in C motor line, with pilot pressure from opposite line	D

*) To be filled in by Bosch Rexroth DC-IA/EHD

3 Functional description

General

The counter balance valve is designed for use with Hägglunds Compact motors CA and CB.

The valve can be mounted directly onto the motors. The valve provides a counter balance function on one or both motor lines depending on the configuration. Maximum operating pressure is 350 bar (5076 psi) and maximum flow 480 l/min (127 gpm).

The valve is available in four main configurations

- A.** Counter balance function in P and C lines, with pilot pressure from opposite line or external Cx and Px
- B.** Counter balance function in P motor line, with pilot pressure from opposite line or external Cx
- C.** Counter balance function in P motor line, with pilot pressure from opposite line.
- D.** Counter balance function in C motor line, with pilot pressure from opposite line.

Function

The valve provides counter balance control of the associated motor. Various configurations are available with load control on the P line, C line or on both P and C lines. The load pressure generated in the motor line is held by a counter balance cartridge until the pilot pressure from either opposite motor line or an external pilot pressure (Cx) or (Px) reaches the set value. Then the counter balance cartridge opens and allows flow from the motor load line in the non load line. The counter balance cartridge starts to lift at a pilot pressure ratio of 4,5 to 1, thus load pressure versus pilot pressure. A check valve by-passes each counter balance cartridge to give free flow in the non load line.

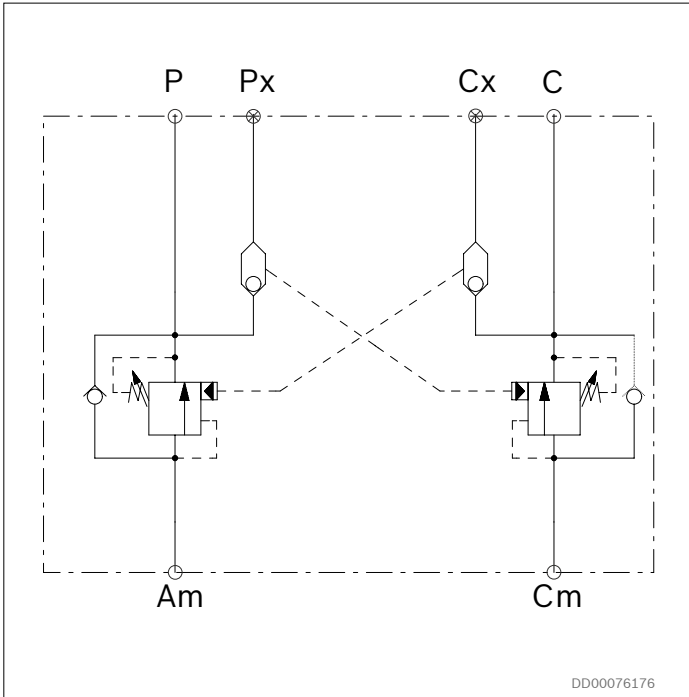

Fig. 1: Hydraulic diagram, configuration A

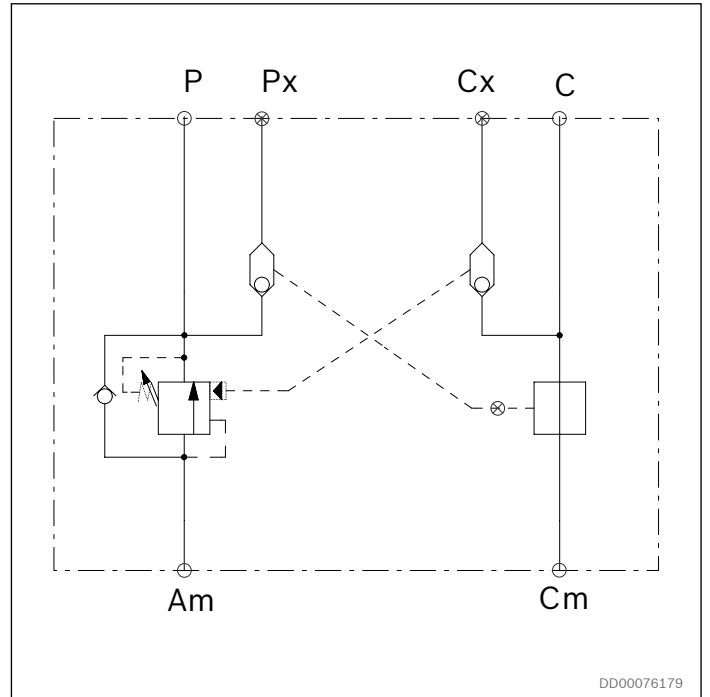

Fig. 2: Hydraulic diagram, configuration B

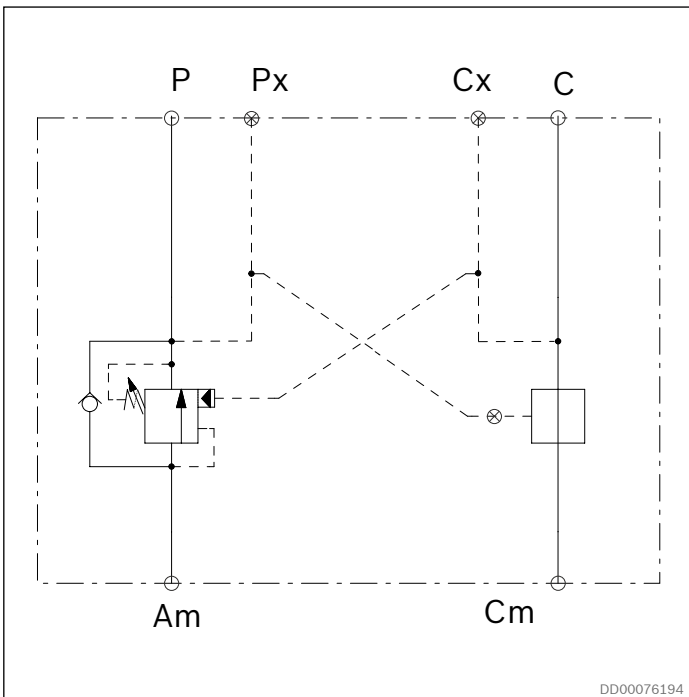

Fig. 3: Hydraulic diagram, configuration C

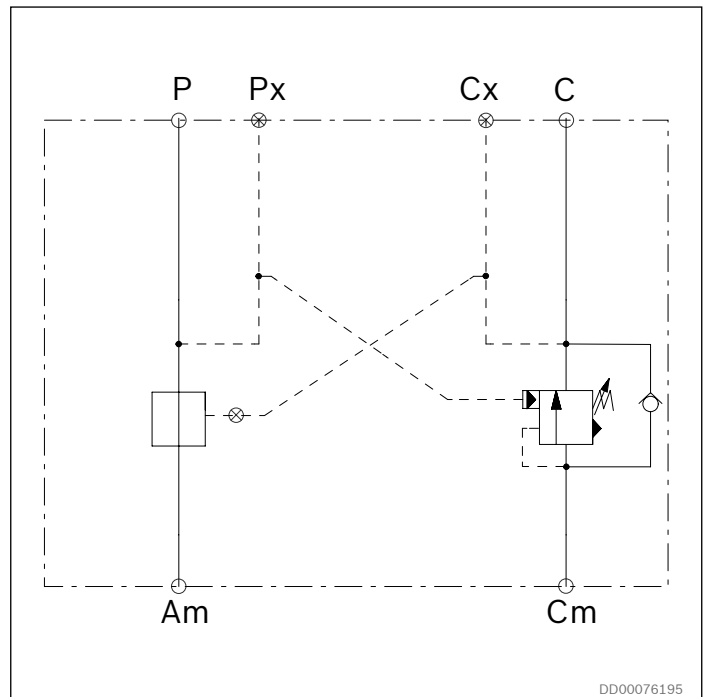

Fig. 4: Hydraulic diagram, configuration D

4 Technical data

Table 1: General data VCBCA 480

	Metric	US
Mechanical specification		
Maximum Operating Pressure	350 bar	5 076 psi
Maximum Load Holding Pressure	350 bar	5 076 psi
Pressure Ratio	4.5:1	4.5:1
Maximum Flow	480 l/min	127 gpm
<i>(see chapter 5 Pressure loss diagram page 7)</i>		
Hydraulic Fluid		
<i>(refer to Data sheet RE 15414 Hydraulic fluid quick reference)</i>		
Maximum Fluid Temperature	+70 °C	+158 °F
Minimum Fluid Temperature	-25 °C	-13 °F
Maximum Viscosity Range	380 cSt	1760 SSU
Minimum Viscosity Range	20 cSt	98 SSU
Recommended Operating Viscosity	40 cSt	187 SSU
Weight		
Counterbalance VCBCA 480	20 kgs	44 lb
Surface treatment	Zinc plated and passivated (Cr3)	

5 Pressure loss diagram

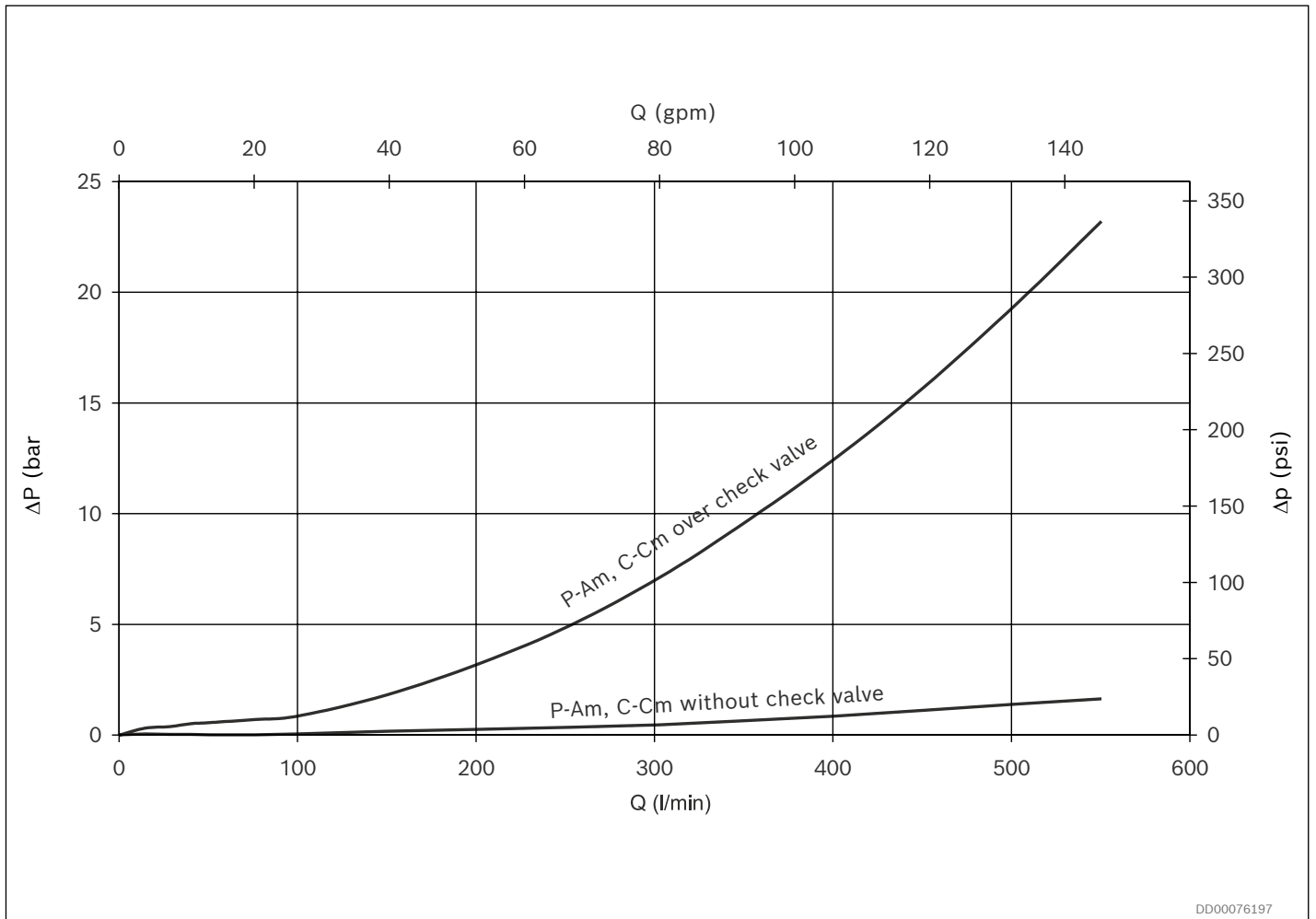

DD00076197

Fig. 9: Pressure loss P-Am, C-Cm over check valve, and without check valve. VCBCA 480 Viscosity 40 cSt

6 Dimensions / Interface

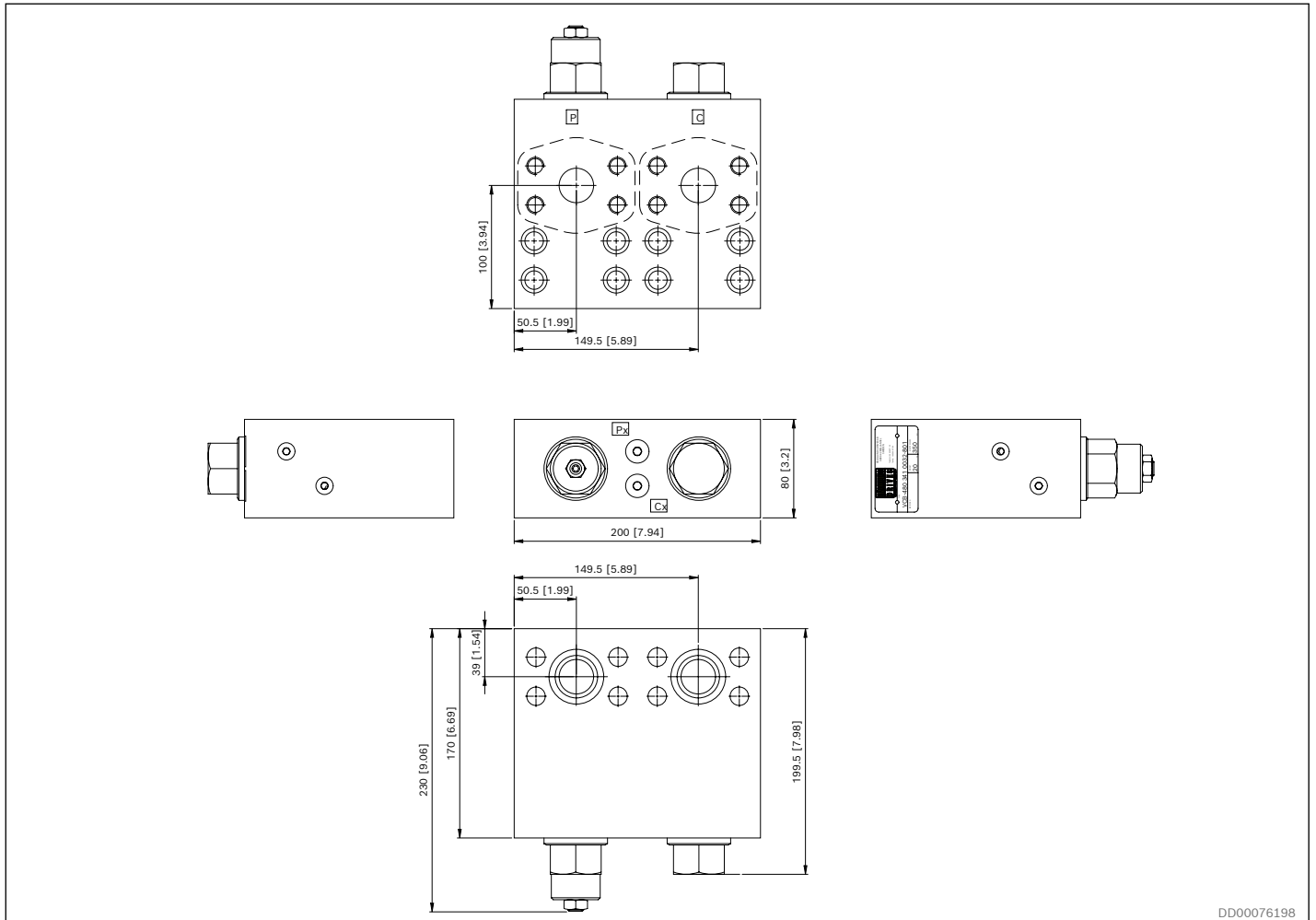

DD00076198

Fig. 10: Dimensions VCBCA 480 configuration B

7 Installation

7.1 Fitting the VCBCA 480 valve on Häggglunds CA and CB

Refer also to the Installation and Maintenance Manual for actual motor.

NOTICE

Contamination of the system!

Risk of damage components.

- ▶ Clean all mounting surfaces before assembly!.

- Remove the protective cover from motor mounting surface
- Place the O-rings (included in delivery) in their proper position on the valve mounting surface. Use clean grease to keep O-rings fixed during assembly.
- Mount the valve against the motor with the ports in their correct position. Ensure that the Am or Cm port (depending of the valve configuration) on the valve is fitted to the high pressure port on the motor.
 - For valve configuration B and C, Am has to be connected to the high pressure port on the motor.
 - For configuration D, Cm has to be connected to the high pressure port.
 - For configuration A, either Am or Cm has to be connected to high pressure port.
- Re-instate paint finish and protect exposed surfaces

Pos	Description
1	8 pcs 1/2" UNC x 102 (included in delivery) Tightening torque 131 Nm (97 lbf ft)
2	Valve VCBCA 480
3	2 pcs O-ring 37.69 x 3.53 NBR 90 (included in delivery)

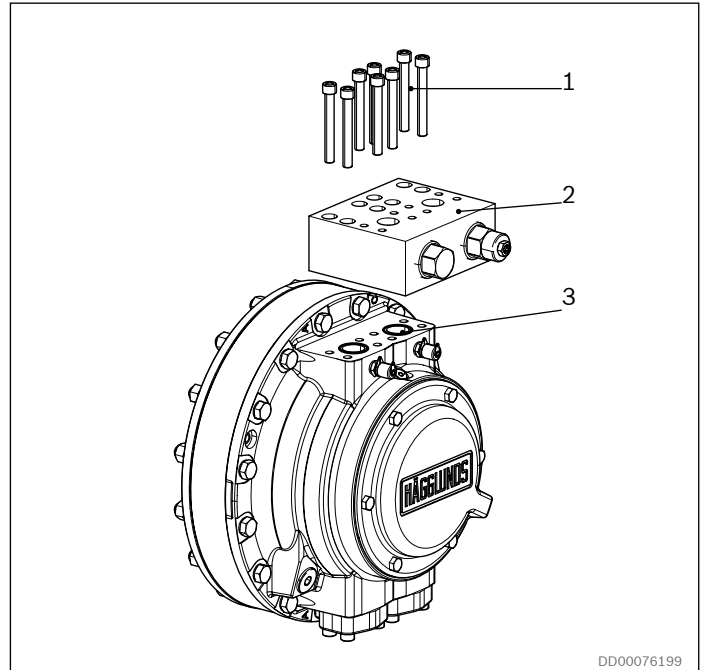

Fig. 11: Häggglunds CA

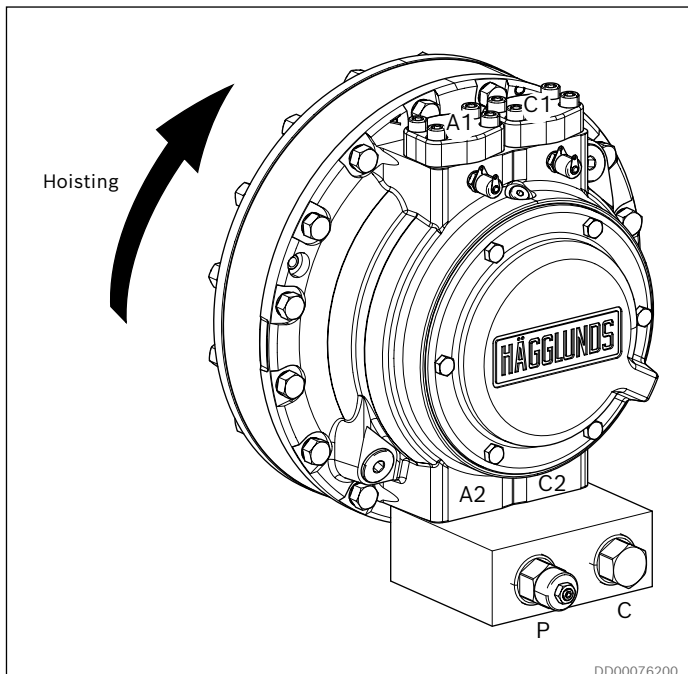

Fig. 12: Example CA configuration C: High pressure in P valve / A2 motor (Hoisting), motor shaft rotating counter clockwise viewed from the motor shaft side. Lowering in C valve / C2 motor port

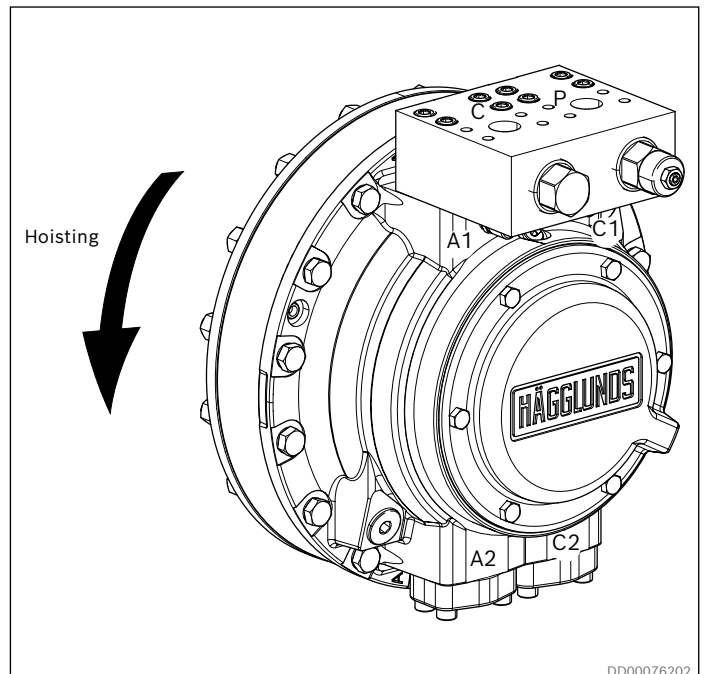

Fig. 13: Example CA configuration C: High pressure in P valve / C1 motor (Hoisting), motor shaft rotating clockwise viewed from the motor shaft side. Lowering in C valve / A1 motor port

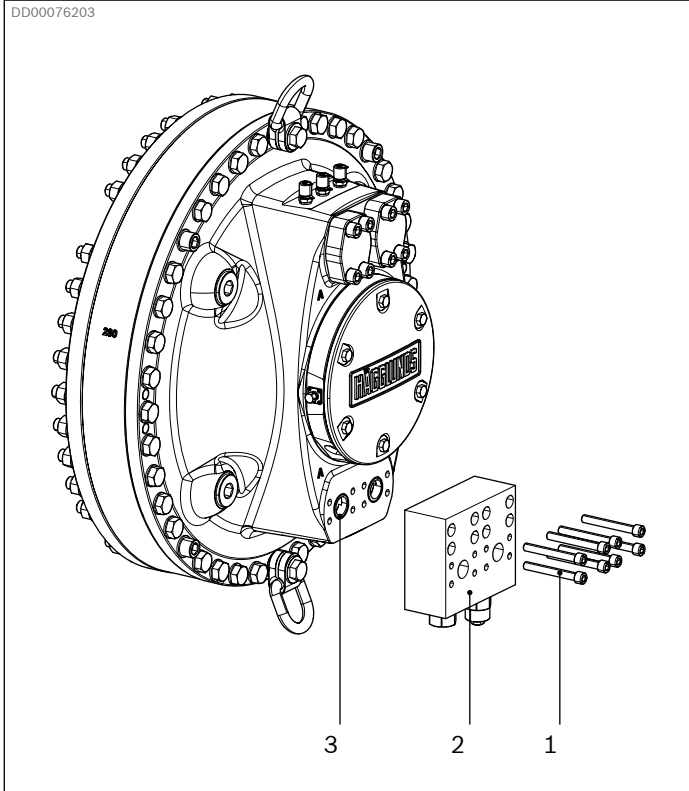

Fig. 14: Hägglunds CB

Pos	Description
1	8 pcs 1/2" UNC x 102 (included in delivery) Tightening torque 131 Nm (97 lbf ft)
2	Valve VCBCA 480
3	2 pcs O-ring 37.69 x 3.53 NBR 90 (included in delivery)

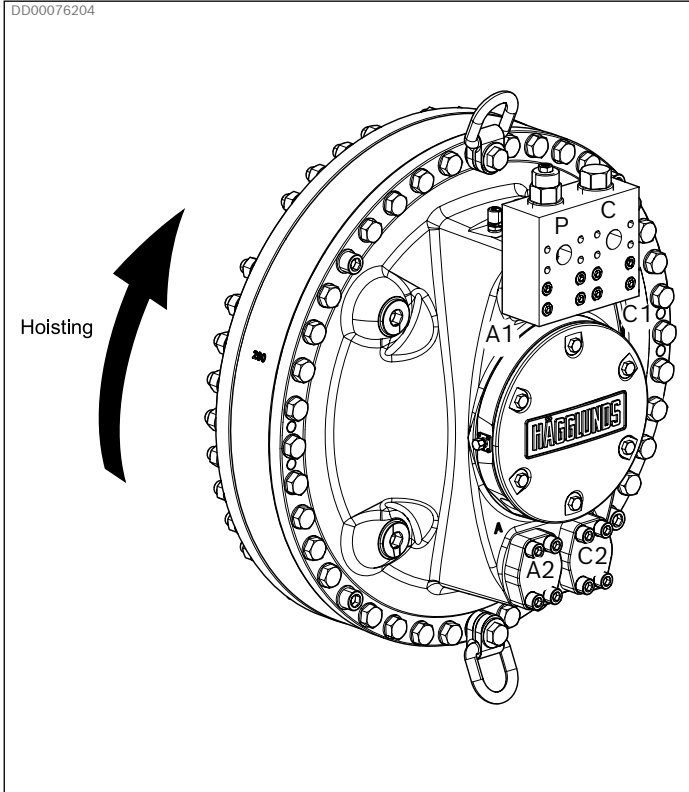

Fig. 15: Example CB configuration C: High pressure in P valve / A1 motor (Hoisting), motor shaft rotating counter clockwise viewed from the motor shaft side. Lowering in C valve / C1 motor port

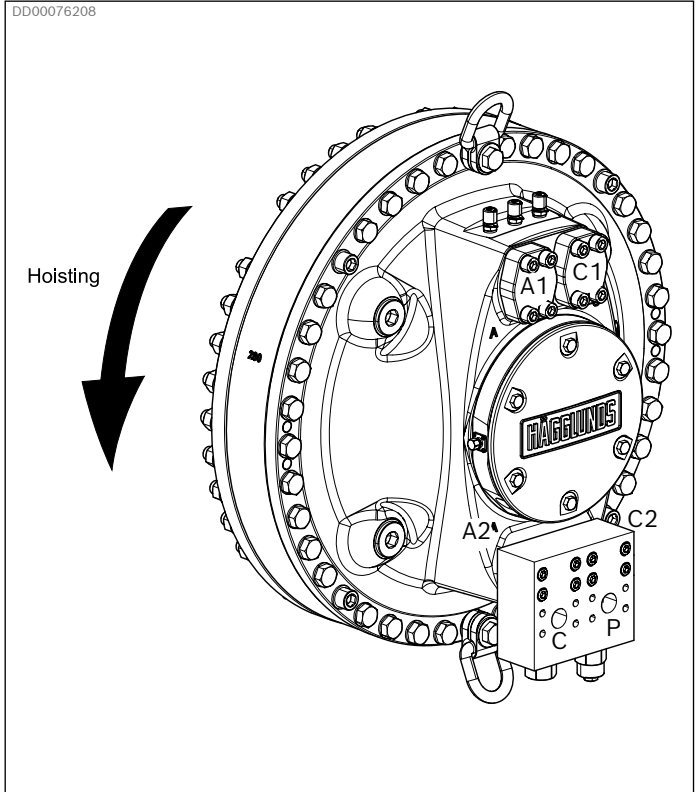

Fig. 16: Example CB configuration C: High pressure in P valve / C2 motor (Hoisting), motor shaft rotating clockwise viewed from the motor shaft side. Lowering in C valve / A2 motor port

7.2 Installation drawing – VCBCA 480

Refer to dimensional drawing: 341 0070

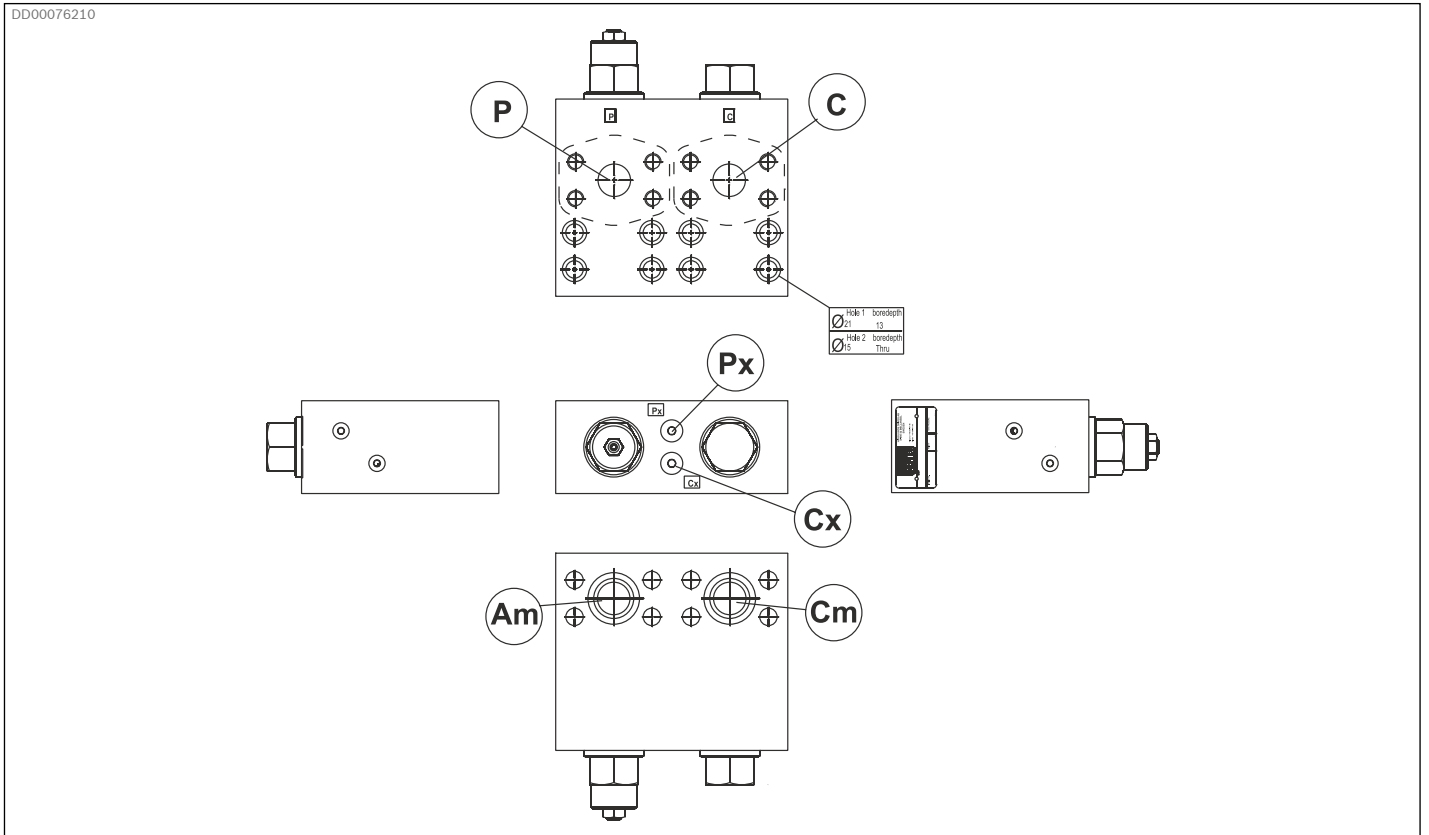



Fig. 17: Installation drawing VCBCA 480

Connection	Description	Port Connection
P, C	Main Connection	SAE 1 1/4 *
Am, Cm	Main Connection	SAE 1 1/4 *
Px, Cx	Remote Pilot Connection	G 1/4

*J518C, Code 62, 414 Bar (6 000 psi)

8 Required and additional documents

Title	Document no	Document type
 Hydraulic fluid quick reference	RE 15414	Data sheet
 VCBCA 480	341 0070 *)	Dimension drawing

Documents at Bosch Rexroth Media Directory

*) Documents only available at LHD extranet. Contact your Bosch Rexroth representative for information.

Bosch Rexroth AB
895 80 Mellansel, Sweden
Tel: +46 (0) 660 870 00
Fax: +46 (0) 660 871 60
documentation.mll@boschrexroth.se
www.boschrexroth.com

The data specified above only serve to describe the product. As our products are constantly being further developed, no statements concerning a certain condition or suitability for certain application can be derived from our information. The information given does not release the user from the obligation of own judgement and verification. It must be remembered that our products are subject to a natural process of wear and aging.