

Häggglunds motors



Radial piston hydraulic motors,
in accordance with ATEX Directive 2014/34/EU

Explosion-proof

ATEX Appendix
Installation and maintenance
manual
RE 15440-X-B2/06.2018

Supersedes
RE 15440-X-B2/
11.2016
English



The data specified above only serve to describe the product. No statements concerning a certain condition or suitability for a certain application can be derived from our information. The information given does not release the user from the obligation of own judgment and verification. It must be remembered that our products are subject to a natural process of wear and aging.

© This document, as well as the data, specifications and other information set forth in it, are the exclusive property of Bosch Rexroth AG. It may not be reproduced or given to third parties without its consent.

Changes in the equipment may occur. We therefore reserve the right to introduce amendments in the manual as we deem necessary without notice or obligations.

The picture on the front page shows the
The original operating instructions were prepared in English.

Contents

1	This documentation	4
1.1	Display of information	4
1.1.1	Safety instructions	4
1.1.2	Symbols	5
2	Safety instructions	6
2.1	About this chapter	6
2.2	Intended use	6
2.3	Improper use	6
2.4	Personnel qualifications	7
2.5	General safety instructions	7
2.6	Product-specific safety instructions	8
2.7	Personal protection equipment	10
3	General instructions on material damage and product damage	11
4	Product identification	13
5	Motor	14
6	Sensors	18
6.1	Temp Sensor	18
6.2	Speed sensors	18
6.2.1	SPDB2	18
6.2.2	Inductive encoder	19

1 This documentation

1.1 Display of information

Standardized safety instructions, symbols, terms and abbreviations are used so that you can use this documentation to work quickly and safely with your product. To give you a better understanding they are explained in the sections below.

1.1.1 Safety instructions

This documentation includes safety instructions in *2.6: Product-specific safety instructions*, *3: General instructions on material damage and product damage* and before a sequence of actions or an instruction for action involving a risk of personal injury or damage to equipment.

The described danger prevention measures must be observed.

Safety instructions are formatted as follows:

! SIGNAL WORD

Type of risk

Consequences of non-observance

- ▶ Safety precautions
- ▶ <List>

- **Warning sign:** Draws your attention to the hazard
- **Signal word:** Indicates the degree of hazard
- **Type of risk!:** Specifies the type and source of the hazard
- **Consequences:** Describes the consequences of non-compliance
- **Precaution:** Specifies how the hazard can be prevented



Table 1: Risk categories to ANZI Z535.6-2006

Warning signs, signal word	Meaning
! DANGER	Indicates a dangerous situation which will result in death or serious physical injury unless averted.
! WARNING	Indicates a dangerous situation which could result in death or serious physical injury unless averted.
! CAUTION	Indicates a dangerous situation which could result in minor to moderate physical injury unless it is averted.
NOTICE	Material damage: the product or its environment could be damaged.

1.1.2 Symbols

The symbols below indicate instructions which are not safety-relevant but help to make the documentation easier to understand.

Table 2: Key to symbols

Symbol	Meaning
	You will be unable to use or operate the product optimally unless this information is observed.
▶ ▶	Individual self-contained action (alternatives)
1. 2. 3.	Numbered operating instruction: The numbers indicate the actions follow one another in sequence
	Center of gravity Markings on packaging to indicate where the center of gravity are.

2 Safety instructions

2.1 About this chapter

This product was made in accordance with the generally accepted rules of the art but there is a risk of personal injury and damage to property unless you follow this chapter and the safety instructions in this documentation.

- ▶ Read this documentation carefully through in full before using product.
- ▶ Keep this documentation so it is accessible to all users at all times.
- ▶ Always give products to third parties with the documentation required.

2.2 Intended use

The Hägglunds motor is a radial piston hydraulic motor.

The motor fulfills the requirements in accordance with ATEX Directive 2014/34/EU.

In the application the Hägglunds motor is classified as a component in the sense of the EU machine directive 2006/42/EC. A partly completed machinery is exclusively intended to form an incomplete or a complete machine together with other components or partly completed machineries. The motor may only be commissioned after it has been installed in the machine/system for which it is intended and the safety of the entire system has been established in accordance with the machine directive.

Intended use includes having read and understood the complete documentation, especially the chapter 2: *Safety instructions*.

The product is intended for the following use:

- Radial piston motor in open or closed circuit: The radial piston motor is only approved to be used in motor mode or pump mode for hydrostatic drives.

Observe the technical data, application and operating conditions and performance limits as specified in the product-specific data sheet and in the order confirmation.

2.3 Improper use

Any use other than that described as intended use shall be considered as improper and is therefore impermissible.

Bosch Rexroth shall accept no liability whatsoever for damage resulting from improper use. The user shall bear all risks arising from improper use.

Similarly, the following foreseeable faulty usages are also considered to be improper:

- Using outside the operating parameters approved in the product-specific data sheet or in the order confirmation (unless customer-specific approval has been granted)
- Use of fluids outside of the standards as specified in Data sheet RE 15414 Hydraulic fluid quick reference.
- Modification of factory settings by non-authorized persons

- Use of add/on parts (e.g. mountable filter, control unit, valves) that are not specified by Bosch Rexroth has to be approved by contact at Bosch Rexroth.
- Extension or conversion is not permissible and has to be approved by contact at Bosch Rexroth.
- Using the Radial piston motor under water without necessary additional measures.
- Using the Radial piston motor when the exterior pressure is greater than the interior pressure (case pressure).
- Using the Radial piston motor in an aggressive atmosphere without necessary additional measures.

2.4 Personnel qualifications

The activities described in this documentation require basic mechanical, electrical and hydraulic knowledge, as well as knowledge of the associated technical terms. For transporting and handling the product, additional knowledge is necessary with regard to working with a lifting device and the corresponding attachment equipment. In order to ensure safe use, these activities may therefore only be carried out by appropriate qualified personnel or an instructed person under the direction and supervision of qualified personnel.

Qualified personnel are those who can recognize possible hazards and institute the appropriate safety measures due to their professional training, knowledge, and experience, as well as their understanding of the relevant regulations pertaining to the work to be done. Qualified personnel must observe the rules relevant to the subject area and have the necessary hydraulic knowledge.

Hydraulic knowledge means, for instance:

- reading and fully understanding hydraulic diagram,
- fully understanding in particular the interrelationships regarding safety devices and having knowledge on the function and assembly of hydraulic components.



Bosch Rexroth offers training support for special fields. For more information about training, please contact your Bosch Rexroth representative.

2.5 General safety instructions

- Follow current accident prevention and environmental protection rules.
- Observe the safety rules and regulations of the country in which the product is used.
- Do not use Bosch Rexroth products unless they are in perfect working order.
- Follow all the instructions on the product.
- Persons who install, operate, remove or maintain Bosch Rexroth products must not consume any alcohol, drugs or pharmaceuticals that may affect their ability to respond.
- Use only Bosch Rexroth spare parts to avoid the risk of personal injury through using unsuitable parts.
- Comply with the technical data and ambient conditions stated in the product documentation.

- If unsuitable products are fitted or used in safety-critical applications, unintended operating conditions may arise which could cause personal injury and damage to property. So do not use a product for safety-critical applications unless that use is specifically stated and allowed in the product documentation, e.g. in wrong explosion risk areas or in safety-critical controls (operating safety).
- You may only commission the product if it has been determined that the end product (e.g. machinery or a system) into which the Bosch Rexroth products are installed complies with the country-specific provisions, safety regulations and standards of the application.

2.6 Product-specific safety instructions

DANGER

Danger from excessively high pressure!

Danger to life or risk of injury, damage to equipment!

Operating the motor above the permissible maximum pressure can cause components to burst and hydraulic fluid to escape under high pressure.

- ▶ Operate the motor only within permissible maximum pressure.

Danger from suspended loads!

Danger to life or risk of injury, damage to equipment!

Improper transportation may cause the Hågglunds motors to fall down lead to injuries e.g. crushing or broken bones or damage to the product.

- ▶ Make certain that the forklift truck or lifting device has adequate lifting capacity.
- ▶ Never stand under or put you hands under suspended loads.
- ▶ Ensure your position is stable during transportation.
- ▶ Use your personal protective equipment (e.g. safety glasses, safety gloves, suitable working clothes, safety shoes).
- ▶ Use suitable lifting device for transport and storage, installation and for removal and repair. Make sure the motor is well mounted or anchored when the lifting device is disconnected.
- ▶ Observe the prescribed position of the lifting strap.
- ▶ Observe the national laws and regulations on work and health protection and transportation.

Pressurized machine/system!

Danger to life or risk of injury, serious injuries when working on machines/systems not shutdown! Damage to equipment!

- ▶ Protect the complete system against being energized.
- ▶ Make sure that the machine/system is depressurized. Please follow the machine/system manufacturer's instructions.
- ▶ Do not disconnect any line connections, ports and components when the machine/system is pressurized.
- ▶ Switch off all power-transmitting components and connections (electric, pneumatic, hydraulic, mechanical) in accordance with the manufacturer's instruction and secure them against being switched back on.

 **WARNING****Escaping oil mist!**

Risk of explosion, fire, health hazard, environmental pollution!

- ▶ Depressurize the machine/system and repair the leak.
- ▶ Keep open flames and ignition sources away from the Hägglunds motors.
- ▶ If Hägglunds motors are to be situated in the vicinity of ignition sources or powerful thermal radiators, a shield must be erected to ensure that any escaped hydraulic fluid can not ignite, and to protect hose lines from premature aging.

Static discharge

Cleaning the motor with a dry rug may lead to explosions through electrostatic discharge that may cause severe injuries and even death.

- ▶ Do not use a dry rug for cleaning!

Lack of grounding

Risk of explosion that may cause severe injuries and even death.

- ▶ Remember the lock washer on grounding point when remounting details.

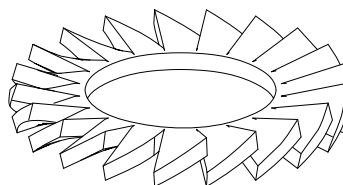

CAUTION

High noise development in operation!

Danger of hearing damage, deafness!

The noise emission of Hägglunds motors depends on speed, operating pressure and installation conditions.

- ▶ Always wear hearing protection when in the vicinity of the operating radial piston motor.

Hot surfaces on the radial piston motor!

Risk of burns!

- ▶ Allow the Hägglunds motors to cool down sufficiently before touching it.
- ▶ Wear heat-resistant protective clothing, e.g. gloves.

Improper routing of cables and lines!

Tripping hazard and damage to equipment!

- ▶ Lay cables and lines so that they can not be damaged and nobody can trip over them.

Contact with hydraulic fluid!

Hazard to health/health impairment e.g. eye injuries, skin damage, toxication during inhalation!

- ▶ Avoid contact with hydraulic fluids.
- ▶ When working with hydraulic fluids, strictly observe the safety instructions provided by the lubricant manufacturer.
- ▶ Use your personal protective equipment (e.g. safety glasses, safety gloves, suitable working clothes, safety shoes).
- ▶ If hydraulic fluid should, nevertheless, come into contact with your eyes or bloodstream or is swallowed, consult a doctor immediately.

Escaping hydraulic fluid due to machine/system leakage!

Risk of burns and risk of injury due to escaping oil jet!

- ▶ Depressurize the machine/system and repair the leak.
- ▶ Never attempt to block or seal the leak or oil jet with a cloth.

2.7 Personal protection equipment

The personal protective equipment is the responsibility of the user of the Hägglunds motors. Observe the safety regulations and provisions of your country. All components of the personal protective equipment must be intact.

3 General instructions on material damage and product damage

NOTICE

Danger from improper handling!

Product can be damaged!

- ▶ Do not expose the product to an impermissible mechanical load.
- ▶ Never use the product as a handle or step.
- ▶ Do not place/lay any objects on the product.
- ▶ Do not strike the Häggglunds motor or any part of it or its accessories.
- ▶ Do not set/place the Häggglunds motor on the drive shaft or fittings.
- ▶ Do not strike fittings (e.g. sensors or valves).
- ▶ Do not strike sealing surfaces (e.g. service line ports).
- ▶ Leave the protective covers on the Häggglunds motor until shortly before the lines are connected.
- ▶ Do not perform electro-welding on the Häggglunds motor.

Damage to equipment due to improper lubrication!

Product can be damaged or destroyed!

- ▶ Never operate the Häggglunds motor with insufficient hydraulic fluid.
- ▶ When commissioning a machine/system, make sure that the case interior and the service lines of the Häggglunds motor are filled with hydraulic fluid and remain filled during operation.
- ▶ Check the hydraulic fluid level in the case interior regularly; if necessary, recommission. With above-reservoir installation, the case interior may drain via the reservoir line after longer standstill periods (air enters via the shaft seal) or via the service line (gap leakage). The bearings are thus insufficiently lubricated at switch on.

Mixing of hydraulic fluids!

Product can be damaged!

- ▶ Before installation, remove all fluids from the Häggglunds motor to prevent mixing with the hydraulic fluid used in the machine/system.
- ▶ Any mixing of hydraulic fluids of different manufacturers or different types of the same manufacturer is not permissible in general.

NOTICE

Contamination of the hydraulic fluid!

The cleanliness of the hydraulic fluid has a considerable impact on the cleanliness and service life of the hydraulic system. Contamination of the hydraulic fluid could cause premature wear and malfunctions!

- ▶ Make sure that the working environment at the installation site is fully free of dust and foreign substances in order to prevent contaminants, such as welding beads or metal cuttings, from getting into the hydraulic lines and causing product wear or malfunctions. The Hägglunds motor must be installed in a clean condition.
- ▶ Use only clean connections, hydraulic lines and attachments (e.g. measuring equipment).
- ▶ No contaminants may enter the connections when they are plugged.
- ▶ Before commissioning, make sure that all hydraulic connections are tight and that all of the connection seals and plugs are installed correctly to ensure that they are leakproof and fluids and contaminants are prevented from penetrating the product.
- ▶ Use a suitable filter system to filter hydraulic fluid during filling to minimize solid impurities and water in the hydraulic system.

Improper cleaning!

Product can be damaged!

- ▶ Plug all openings with the appropriate protective equipment in order to prevent detergents from entering the hydraulic system.
- ▶ Never use solvents or aggressive detergents. Use only water and, if necessary, a mild detergent to clean the Hägglunds motor.
- ▶ Do not point the power washer at sensitive components, e.g. shaft seal, electrical connections and components.
- ▶ Use lint-free cloths for cleaning.

Environmental pollution due to incorrect disposal!

Careless disposal of the Hägglunds motor and its fittings, the hydraulic fluid and the packaging material could lead to pollution of the environment!

- ▶ Dispose of the Hägglunds motor, hydraulic fluid and packaging in accordance with the national regulations in your country.
- ▶ Dispose of the hydraulic fluid in accordance with the applicable safety data sheet for the hydraulic fluid.

Escaping or spilling hydraulic fluid!

Environmental pollution and contamination of the ground water!

- ▶ Always place a drip tray under the Hägglunds motor when filling and draining the hydraulic fluid.
- ▶ Use an oil binding agent if hydraulic fluid is spilled.
- ▶ Observe the information in the safety data sheet for the hydraulic fluid and the specifications provided by the system manufacturer.

The warranty applies only to the delivered configuration.

The entitlement to warranty cover will be rendered void if the product is incorrectly installed, commissioned or operated, or if it is used or handled improperly.

4 Product identification

- 1 Type code
- 2 Serial number
- 3 Weight
- 4 Manufacturer
- 5 Max pressure

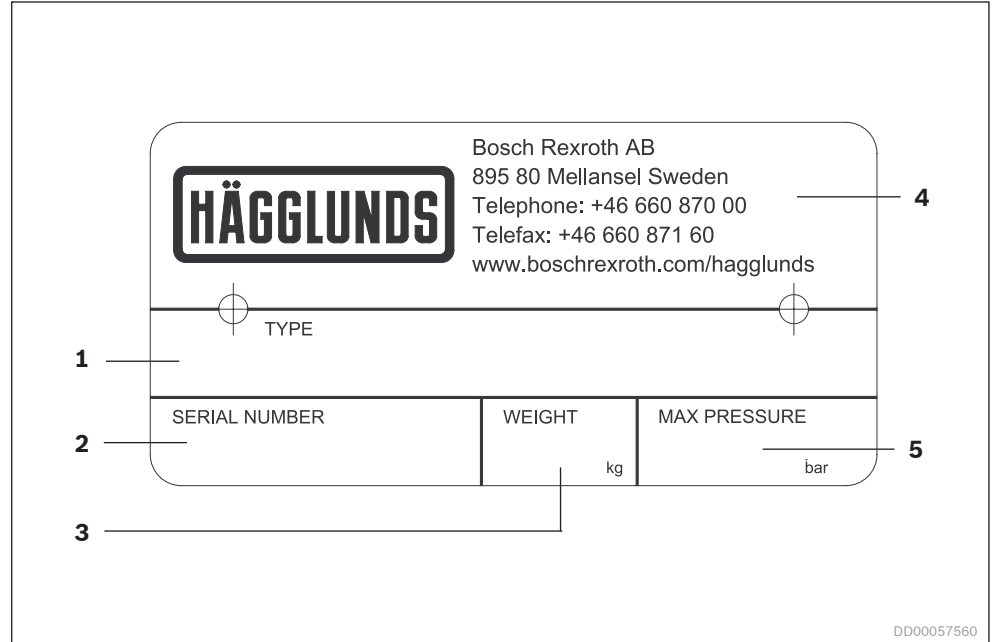

Fig. 1: Product identification

- 6 Name of the certificate issuer
- 7 Year and reference for the certificate
- 8 ATEX classification
- 9 CE marking acc. to ATEX directive

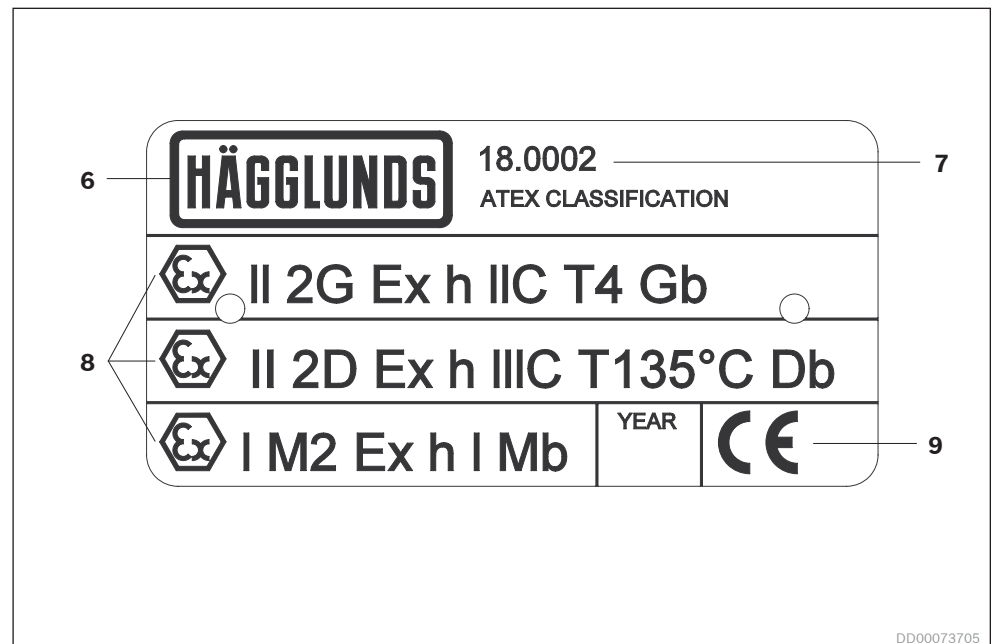

Fig. 2: ATEX identification

5 Motor

Pressure limitation

If there is a risk for pressure peeks over 350 bar in the hydraulic system, a cross-over valve must be installed to limit the pressure level.

Voltage equalization

The Hägglunds hydraulic motor must be connected to external ground for voltage equalization. The grounding point of the Hägglunds hydraulic motor is on one of the screws for port connection as per Fig. 3. Minimum required cable area for equalization connection is 10 mm².

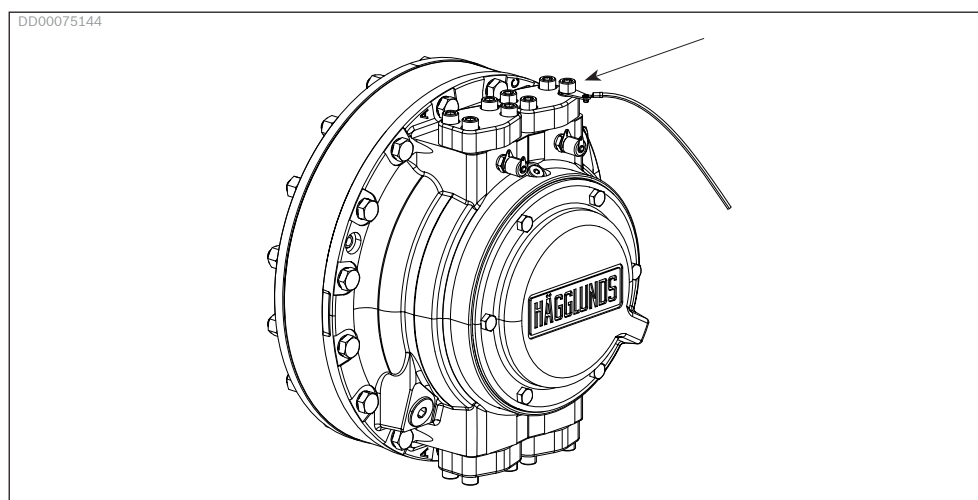

Fig. 3: Grounding of motor

Table 3: Grounding assembly details

Pos	Qty	Mat.nr.	Description
1	1	R939062517	Washer M12-M6-EN1.4401
2	1	R939062518	Washer M16-M6-EN1.4401
3	1	R939062519	Washer M20-M6-EN1.4401
4	1	R939062520	Washer 5/8-M6-EN1.4401
5	2	R913018264	Washer ISO7092-12-200HV-A4
6	1	R913049653	Washer ISO8738-16-160HV-A4
7	1	R913049655	Washer ISO8738-20-160HV-A4
8	1	R913015066	Hexagon screw ASME B18.2.1-5/8 UNC X1 1/2-GRADE5-A3K Tightening torque 140 Nm (103 lbf ft)
9	1	R913049670	Pan-head screw ISO14583-M6X16-A4-70 Tightening torque 6.3 Nm (4.6 lbf ft)
10	1	R911373380	Terminal lug KR-M6/0,75-10,0NN11,0-11,5
11	1	R913015031	Serrated lock washer M6 DIN6798-A6,4-A4
12	1	R913049671	Hexagon Nut M6 ISO7042-M6-A4-70
13	1	R913015261	Hexagon screw ISO4017-M10X14-8.8-A3K

The parts for grounding (washers, screws and terminal lug) are delivered in a small bag attached to the motor. The bag contains parts to fit all motor types so all parts will not be used. Cable is not included in the delivery.

It is important to follow the grounding point examples for each motor type. Flange for connection can be selected to best fit the installation.

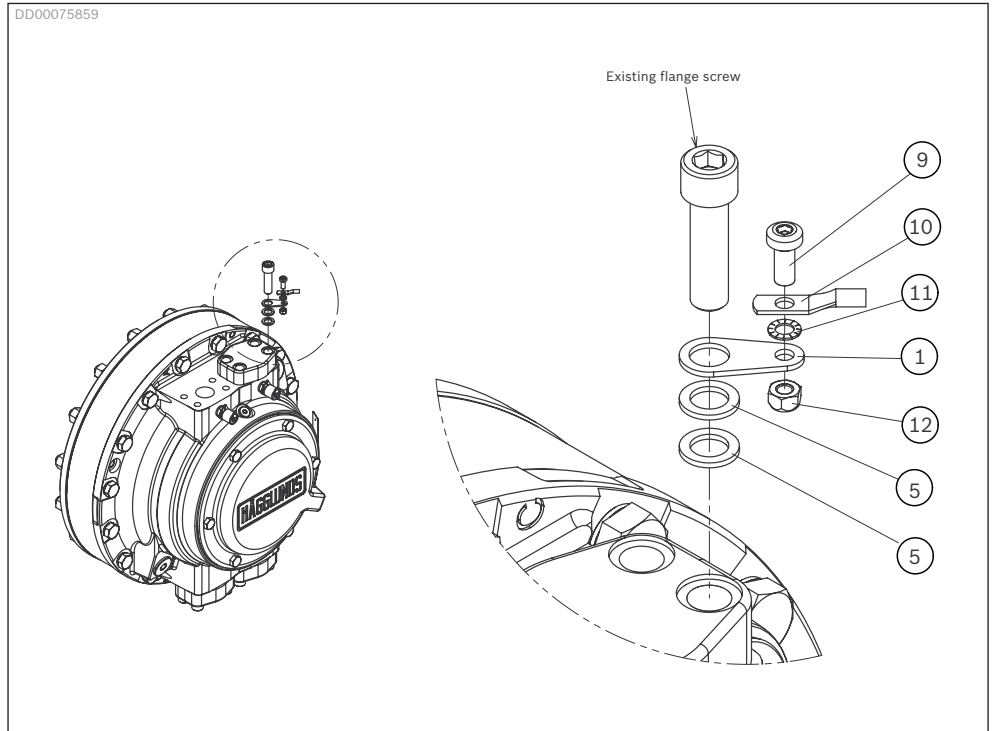

Fig. 4: Grounding point example, Häglunds CA

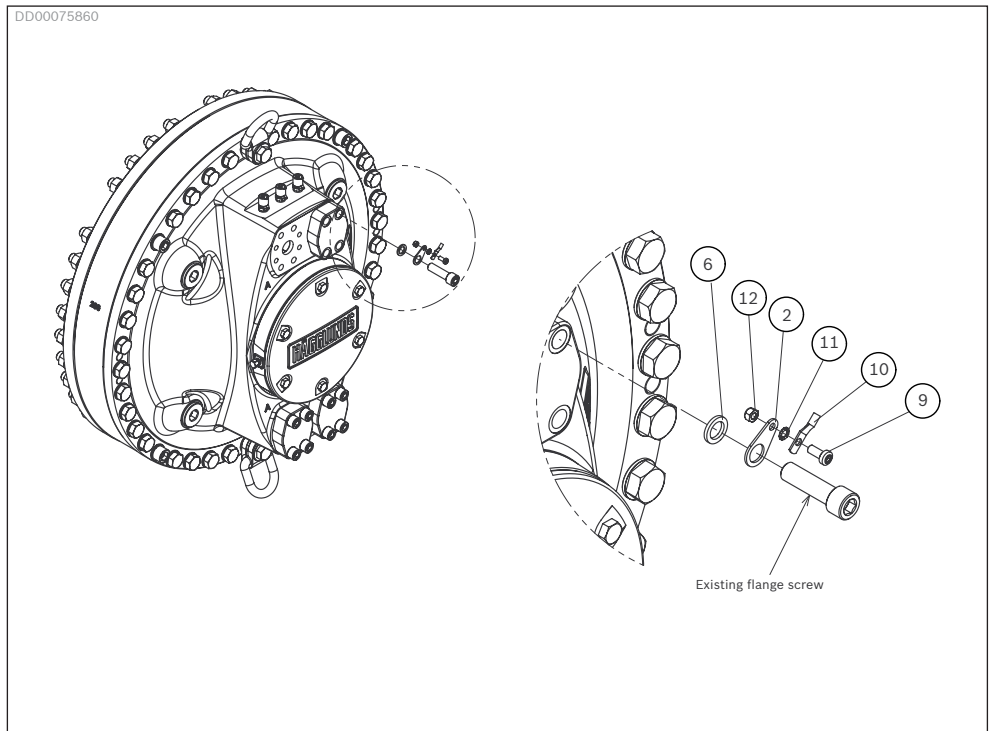

Fig. 5: Grounding point example, Häglunds CB

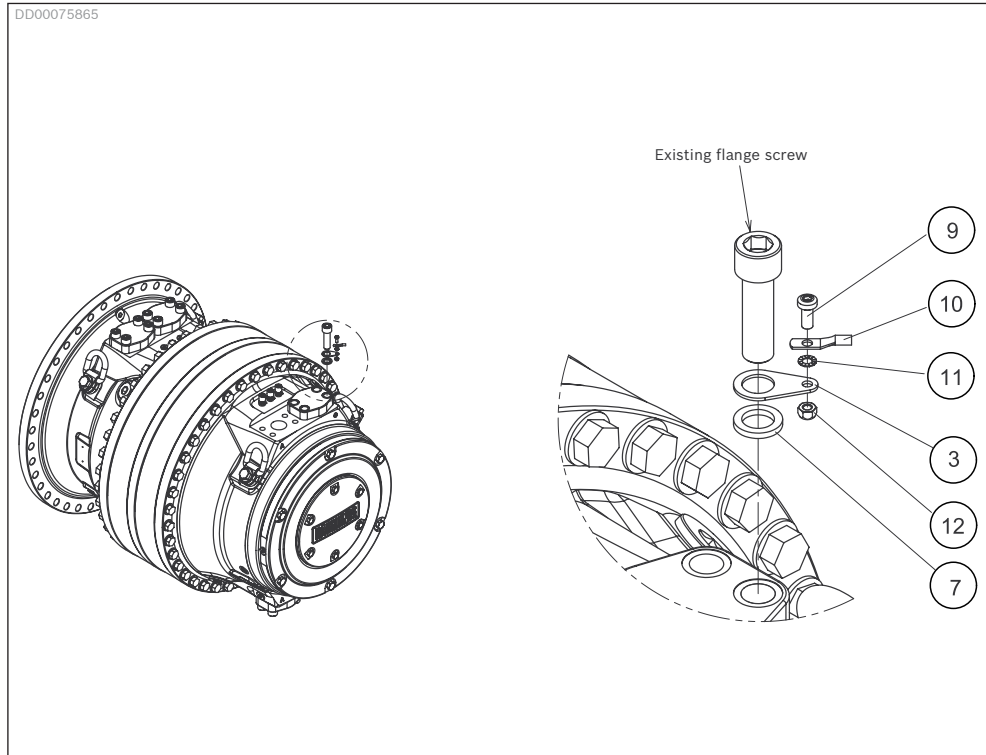

Fig. 6: Grounding point example, Hägglunds CBP

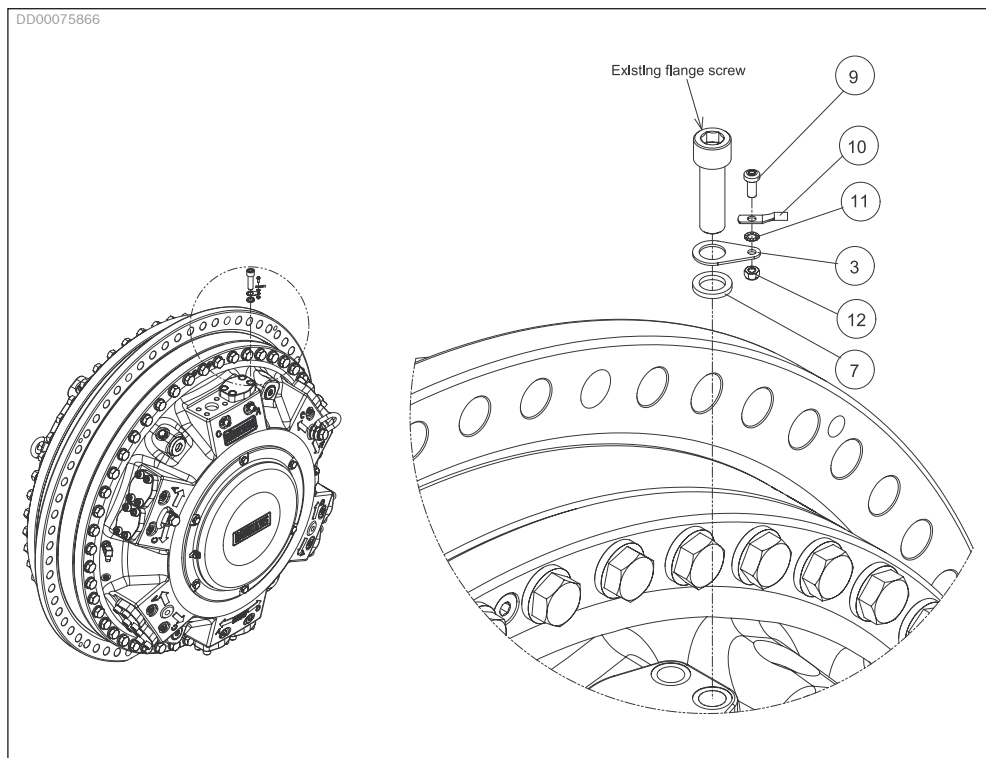

Fig. 7: Grounding point example, Hägglunds CBM

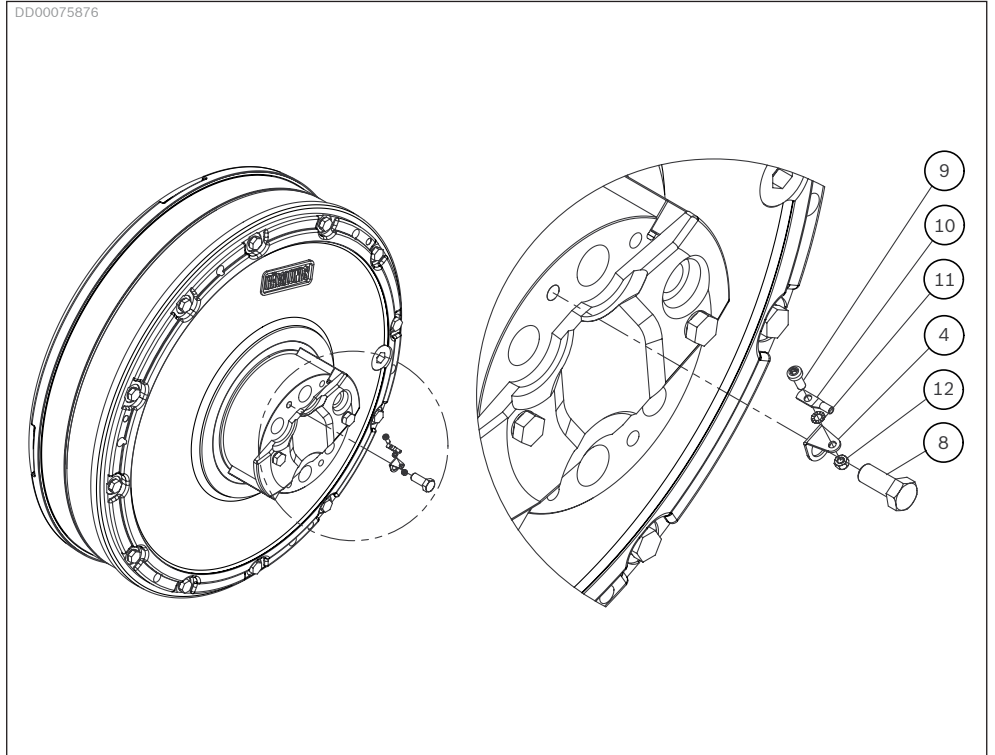

Fig. 8: Grounding point example, Hägglunds Viking 44/64

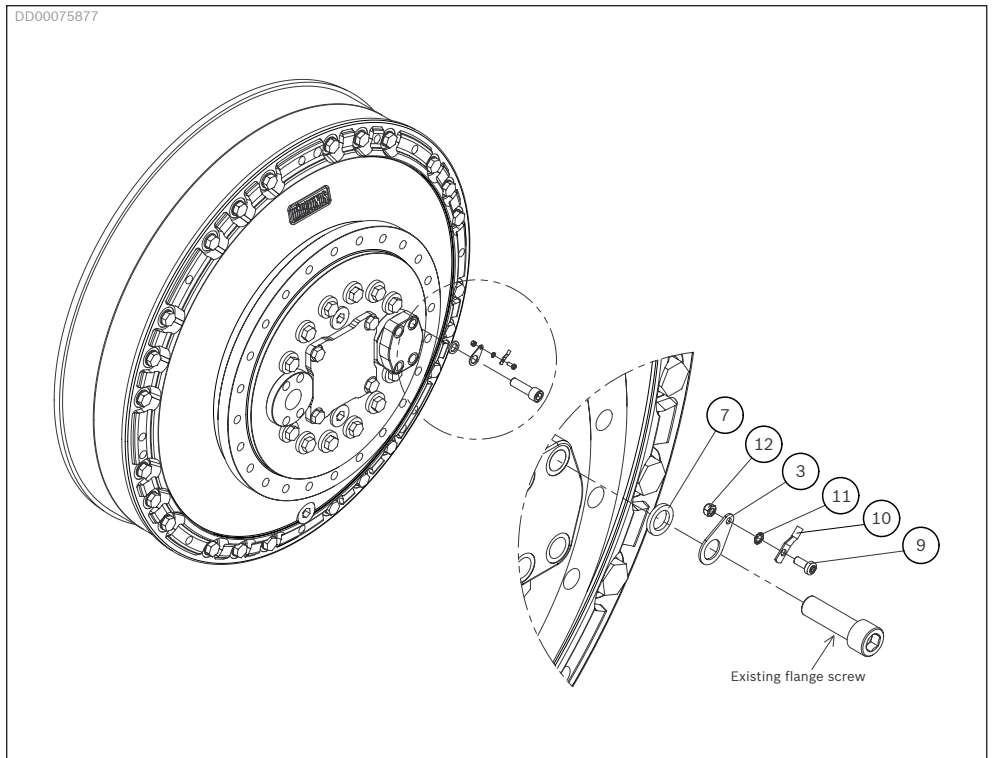

Fig. 9: Grounding point example, Hägglunds Viking 84

6 Sensors

Sensors are optional and their explosive area classification will limit the area classification for the complete motor.

6.1 Temp Sensor

The house temp sensor is of standard PT100 type used as “simple apparatus” (will not add any energy in the electric circuit)

Electrical connection

The temp sensor must be operated via an intrinsically safe amplifier to limit the energy to the explosive zone.

Table 4: Electrical connections, temp sensor

Connector	M12	DIN 60751	
Connection	Pin 1 or 2	Pin 2	+ signal
	Pin 3 or 4	Pin 1 or 3	- signal

6.2 Speed sensors

6.2.1 SPDB2

The SPDB2 speed encoder is a flame proof incremental quad pulse encoder certified Ex d IIC T5 for gas and Ex tD A21 IP65 T95°C for dust.

Electrical connection

Electrical connection is done to screw terminals inside the Exd enclosure under the back cover and fed through the housing via a M20 opening where an Exd IIC certified cable gland and filled cable is required. Maximum allowed supply voltage 30 VDC
A prepared connection set with Exd cable gland, 5 m cable and Exe connection box can be ordered separately to simplify installation, part number R939003770.

Table 5: Electrical connections, SPDB2

Terminal	
1	+9-30 VDC
2	0 V
3	signal 0
4	signal 0 inv.
5	signal 1
6	signal 1 inv.
7	signal 2
8	signal 2 inv.

Voltage equalization

An external ground connection is required to the grounding point on the housing. Minimum required cable area for equalization is 1,5 mm².

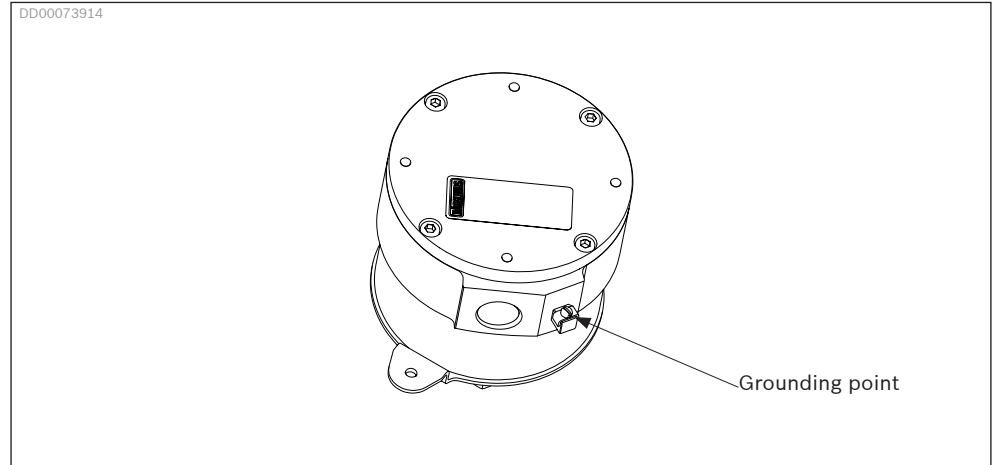

Fig. 10: Grounding of SPDB2

Maintenance and repair

If the back cover has to be opened in Ex environment, wait minimum 15 minutes after power has been switched off before opening to allow internal components to cool down to safe temperature. The encoder is not reparable by the user.

6.2.2 Inductive encoder

The inductive speed encoder is an Namur intrinsic safe incremental single pulse encoder with 40ppr, certified II 2G Ex ia IIC T6 Ga for gas area.

Electrical connection

The inductive speed encoder must be operated via an intrinsically safe switching amplifier to limit the energy to the explosive zone.

Table 6: Electrical connections, inductive encoder

Connector		M12
Connection	Pin1 Pin3	+ signal - signal
Self inductance		2mH
Self capacitance		250nF

Bosch Rexroth AB

SE-895 80 Mellansel

Sweden

Tel. +46 (0) 660 870 00

Fax +46 (0) 660 871 60

documentation.ml@boschrexroth.se

www.boschrexroth.com/hagglunds

Your local contact can be found at:

www.boschrexroth.com/adresses