



**BREVINI**<sup>®</sup>

*Motion Systems*



1800-OILSOL  
1800-645765

<https://oilsolutions.com.au/>

[sales@oilsolutions.com.au](mailto:sales@oilsolutions.com.au)

# Brevini<sup>®</sup> Slewing Drive SD Series

Output torque from 600 Nm to 95.000 Nm



Brevini<sup>®</sup> SD planetary Slewing Drive Series are designed to ensure effective performances and quiet operation with compact design, for Mobile, Construction, Marine, Material Handling and other demanding applications.

# Brevini® Slewing Drive Series

## Modular Design

The modular concept of Brevini® SD planetary slewing drive series, the compact design, together with the customization capability, allow to satisfy any possible application and installation requirements.

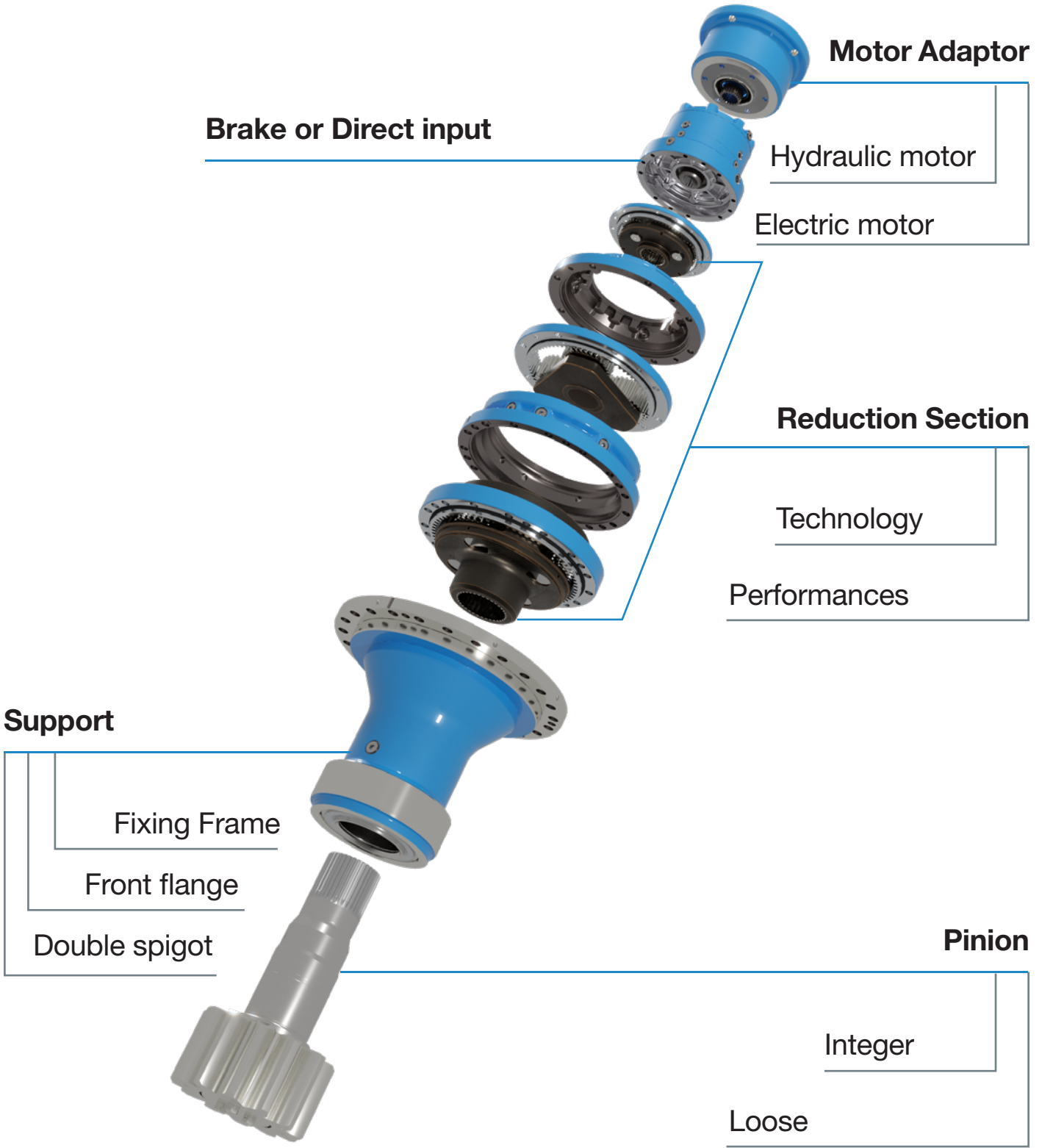

# Output Section



## Pinion

The pinion, that can be customized based on application requirements, is designed using high grade material, specific heat treatment and high quality teeth finishing to achieve the best meshing smoothness and improve its reliability.

- Integer or loose
- Case hardened
- Customizable following the application and ring gear requirements:
  - Grinding
  - Tip relief
  - Crowning
- Designed according metric system
- According to imperial system on request

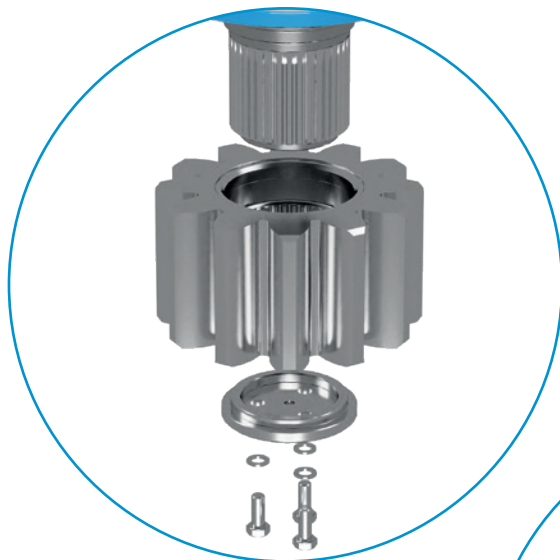

Loose

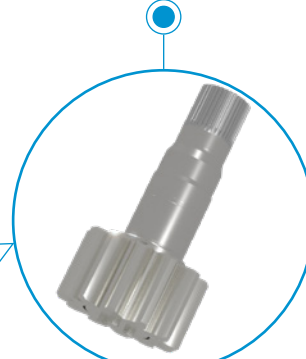

Pinion

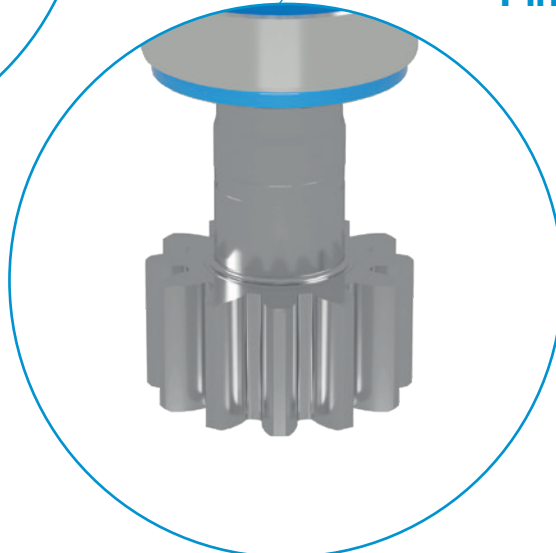

Integer

# Output Section

Engineered to be reliable in harsh condition, low temperature, polluted environment, heavy duty cycle applications and peak loads.



## Support

- Robust design for shock loads
- Tapered roller / spherical-cylindrical
- Bearings
- Grease lubrication outer bearing
- Low temperature design

## Fixing Frame

- Single spigot with fixing front flange
- Double spigot with fixing flange or fixing on ring gear
- Different spigot dimensions and hole pattern configurations

### Single spigot with fixing front flange

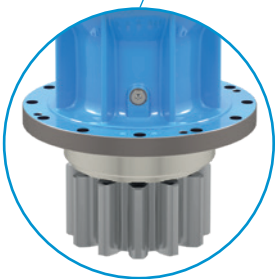

Different spigot dimensions and hole pattern configurations

### Double spigot with fixing flange or fixing on ring gear

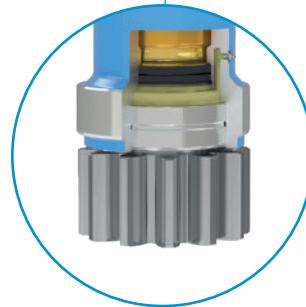
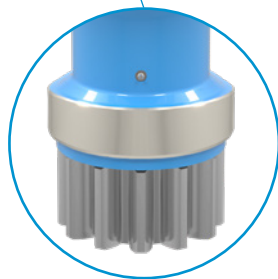

Grease lubrication outer bearing

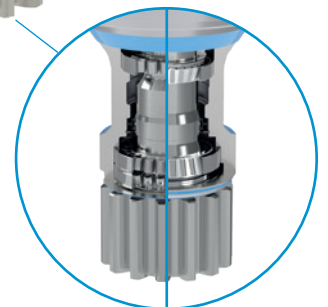

Tapered or spherical and cylindrical bearings



MEWP Output support

# Reduction Section

Gears and bearing are sized to grant the performance and lifetime required by every possible application. The availability of multiple ratios, together with the capability to realize modular solution with multiple reduction stages, allow to satisfy every possible needs required by the transmission and the prime mover, whether hydraulic or electric.



## Reduction section

### Technology

- Planetary gears reduction stages
- Modular design for to realize package with 1, 2 or 3 reduction stages
- Possible reduction ratios from 3 up to 400 and more
- Compact solution



### Performances

- Working Torques from 500 Nm up to 70.000 Nm
- Max Torques from 600 Nm up to 95.000 Nm

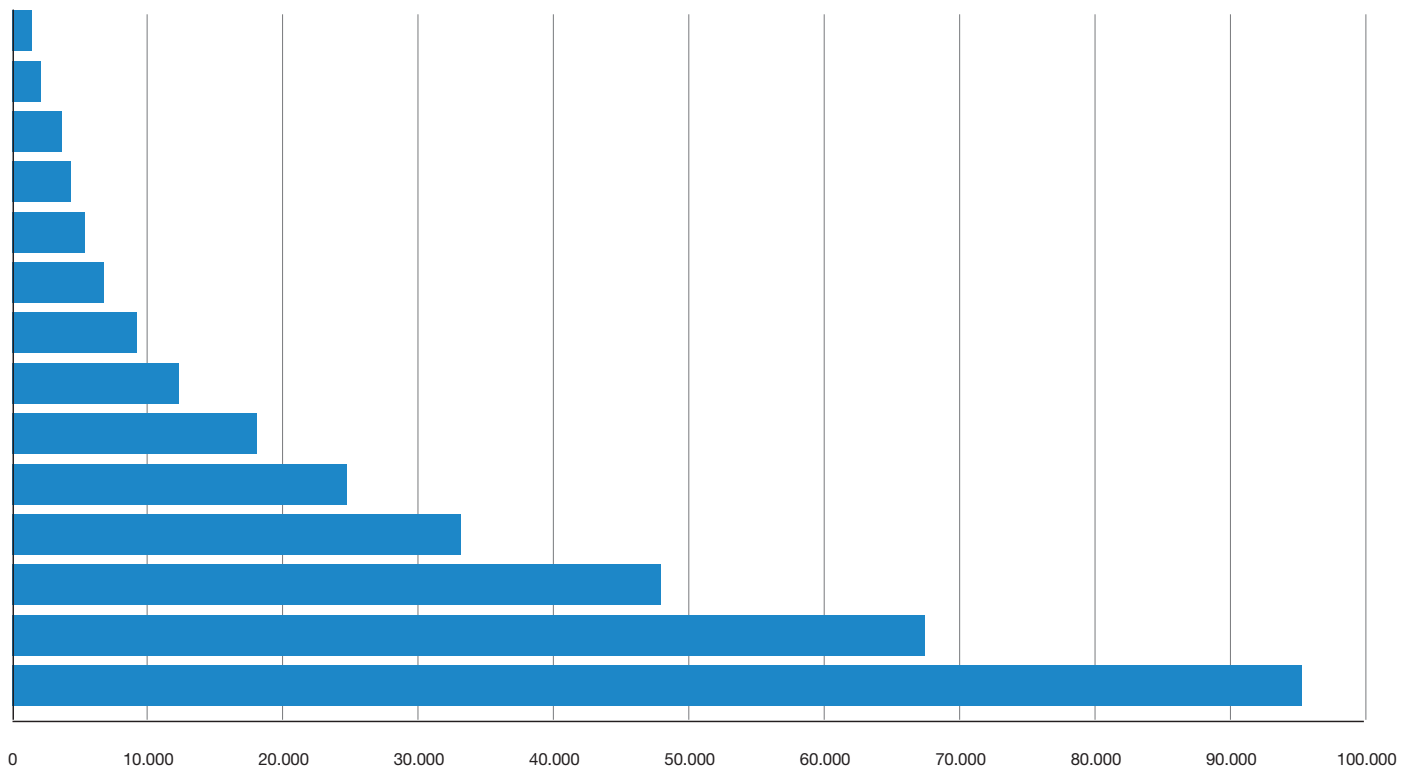

# Input Section

Parking brake design ensure high number of open/close cycles and allows pressure spikes up to 300 bars. Braking torques can be adjusted according application requirements.



## Brake

- SAHR technology (Spring Applied Hydraulic Release)
- Engineered for durability
- SAER technology (Spring Applied Electrically Released)
- “No brake” variant for electric motor direct input
- Expansion tank

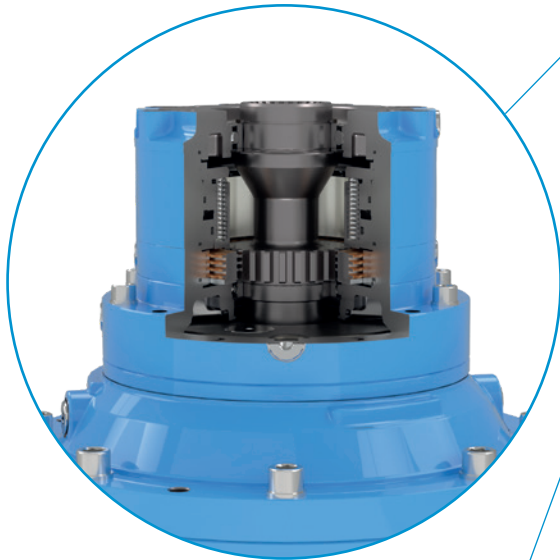

Brake

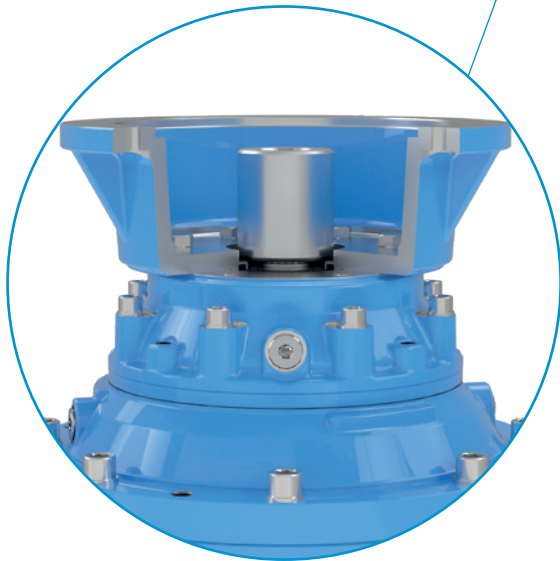

IEC

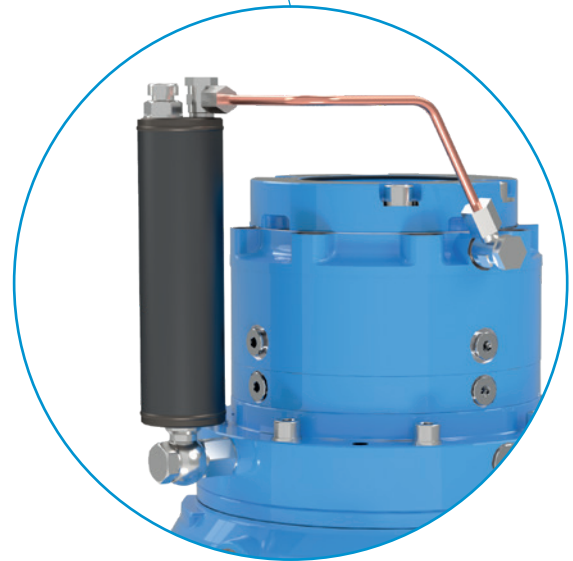

Tank

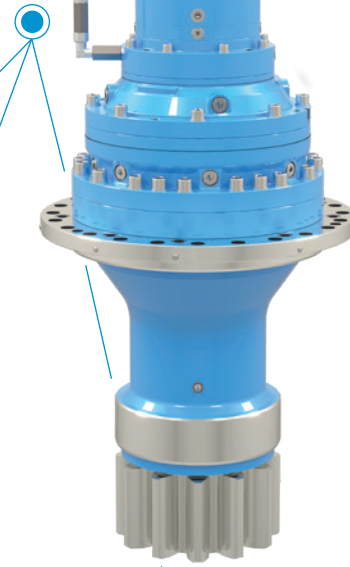

# Input Section

Slew gearboxes can be provided as package which can include: Brevini® hydraulic motor and valve or Dana TM4® electric motor and inverter.

The gearbox standalone solution can allow the installation of both hydraulic and electric motor from all the major brands.



## Motor Adaptor

Package solution can include

### Brevini® Hydraulic Motors

- Orbital motors, peak pressures from 225 up to 310 bars
- Piston motors
- Fixed displacement, bent axis design, peak pressures up to 480 bars
- Fixed displacement, swash plate design, peak pressures up to 350 bars
- Variable displacement, bent axis design, for open and closed circuits, peak pressures up to 480 bars

### Brevini® Valves

- Shockless relief valve
- Anti-cavitation check valve
- Brake release valve

### Dana TM4® Electric Motors

- IPM, SR, SRIPM motor for efficient battery use
- Low voltage motors: 24/96 V - 48/96/144 V
- High voltage motors: 130/450 V

### Dana TM4® Inverters

- Low voltages: from 36/48 V to 72/80V
- High voltage: from 320 V to 800 V

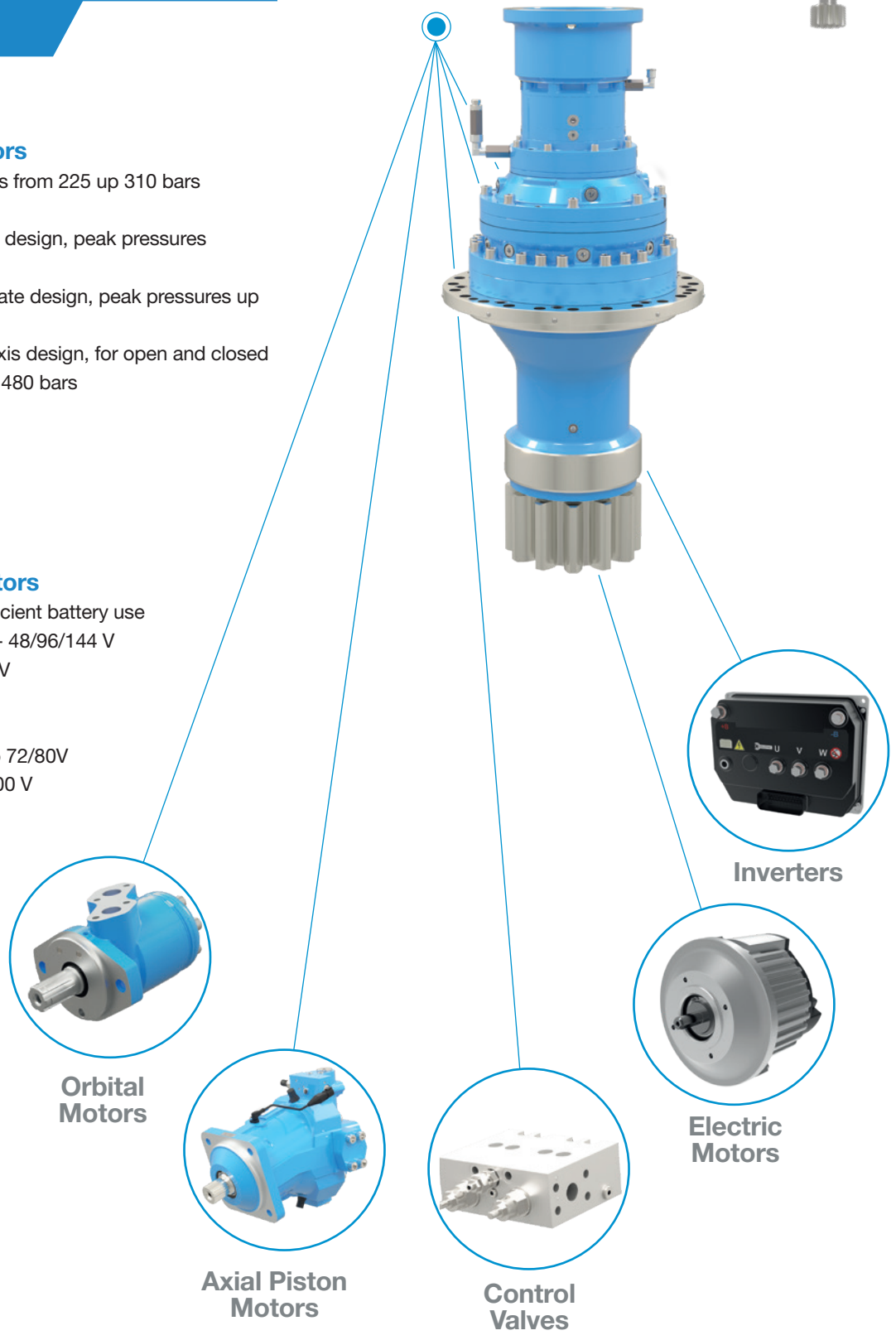

Orbital Motors



Axial Piston Motors

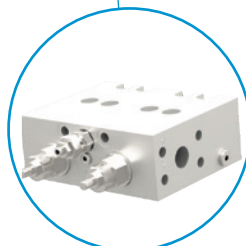

Control Valves



Electric Motors



Inverters

# Applications

Brevini® SD Planetary Slewing Drives series are designed for mobile, construction, marine, heavy duty and material handling applications.



[Dana.com/oh/contact](http://Dana.com/oh/contact)



1800-OILSOL  
1800-645765

<https://oilsolutions.com.au/>

[sales@oilsolutions.com.au](mailto:sales@oilsolutions.com.au)

## Application Policy

Capacity ratings, features, and specifications vary depending upon the model and type of service. Application approvals must be obtained from Dana; contact your representative for application approval. We reserve the right to change or modify our product specifications, configurations, or dimensions at any time without notice.



**BREVINI®**

Motion Systems