



1800-OILSOL
1800-645765

<https://oilsolutions.com.au/>

sales@oilsolutions.com.au



BREVINI[®]

Motion Systems

Installation and Maintenance Manual

Gearmotors V Series

IMM-0021EN
December 2022

DISCLAIMER

The official language chosen by the Product manufacturer is English. No liability is assumed as a result of translations in other languages not in compliance with the original meaning. In case of conflicting language versions of this document, the English original prevails. Dana shall not be liable for any misinterpretation of the content here into. Photos and illustrations might not represent the exact product.

© Copyright 2022 Dana Incorporated

All content is subject to copyright by Dana and may not be reproduced in whole or in part by any means, electronic or otherwise, without prior written approval.

THIS INFORMATION IS NOT INTENDED FOR SALE OR RESALE, AND THIS NOTICE MUST REMAIN ON ALL COPIES.

CONTENTS

1	VERSION TRACKING	5
1.1	MANUAL APPLICABILITY AND SUPPORTED MODELS	5
2	HOW TO USE THIS MANUAL	6
3	UNIT DESIGNATION	7
3.1	DETAILED UNIT DESIGNATION	7
3.2	NAMEPLATE UNIT DESIGNATION	8
4	STANDARD TYPE GEARBOX PARTS LIST	9
4.1	V... TYPES	9
5	SAFETY	10
5.1	INTENDED USE	10
5.2	IMPROPER USE	10
5.3	SAFETY INSTRUCTIONS	11
5.3.1	GENERAL SAFETY INSTRUCTIONS	11
5.4	TIGHTENING TORQUES	13
5.5	CASE OF FIRE	13
5.5.1	SUITABLE EXTINGUISHING AGENTS, PROTECTIVE EQUIPMENT	13
5.5.2	UNSUITABLE EXTINGUISHING AGENTS	13
6	THINGS TO CHECK BEFORE THE GEAR UNIT OR GEARED MOTOR IS INSTALLED	14
6.1	TRANSPORTATION	14
6.2	STORAGE	15
7	INSTALLING THE GEAR UNIT	16
7.1	BEFORE YOU START	16
7.2	CHECK SPLINED SHAFT DIMENSIONS AND TOLERANCES	17
7.3	CHECK DRUM CONNECTION FLANGE (OPTIONAL) DIMENSIONS AND TOLERANCES	18
7.4	CHECK THE AMBIENT TEMPERATURE	18
7.5	CHECK THE VOLTAGE SUPPLY	19
7.6	CHECK THE MOUNTING POSITION	21
7.7	USE THE BREATHER PLUG	21
7.8	CHECK THE OIL LEVEL	21
7.9	CHECK SHAFT ENDS AND MOUNTING FACES	21
7.10	COVER ABRASIVE AMBIENT	22
7.11	CHECK ACCESSIBILITY TO FILLING, BREATHER AND DRAIN PLUGS	22
8	MECHANICAL INSTALLATION	23
8.1	FITTING OUTPUT SHAFT ELEMENTS	24
8.2	CORRECT POSITION OF OUTPUT SHAFT ELEMENTS	24
8.3	FITTING COUPLINGS	25
9	MAINTENANCE & INSPECTION	26
10	LUBRICATION	27
10.1	OIL TYPES	27
10.2	CHANGING THE OIL	28
10.3	OIL LEVELS, PLUGS AND QUANTITIES	29
10.4	MOUNTING POSITIONS	30
11	TROUBLESHOOTING GUIDE	31
12	DISPOSAL	34
12.1	DISPOSAL OF OIL	34
12.2	DISPOSAL OF SEALING	34
12.3	DISPOSAL OF METAL	34

1 VERSION TRACKING

File name	Revision	Date	Changes description
IMM-0021EN_Rev.00 Gearmotors V Series	00	17/10/2022	- Changed layout
IMM-0021EN_Rev.01 Gearmotors V Series	01	07/12/2022	- Updated "Use the breather plug" page 21





1.1 MANUAL APPLICABILITY AND SUPPORTED MODELS

Models
Gearmotors V Series

2 HOW TO USE THIS MANUAL

Take attention to the following safety and warning signs for proper understanding and quick reference.

Table 1:



	Indicates an imminently hazardous situation which, if not avoided, will result in death or serious injury.
	Indicates an imminently hazardous situation which, if not avoided, could result in death or serious injury.
	Indicates a situation which, if not avoided, may result in damage to components.
	Indicates information which may make product service easier to perform.

NOTE:

Important Information.

Hazard pictograms

Table 2:

	General danger
	Electric current
	Moving parts

NOTE:

EC Machinery Directive:

Within terms of the EC machinery directive 2006/42/EC, the gearboxes are considered as not autonomous machine, but as a component to install in machines.

Operation is prohibited within the area of validity of the EC directive, until it has been determined that the machine, in which this product is installed, corresponds to the regulations within this directive.

The operating instructions contain important information to ensure;

- Trouble-free operation
- Fulfilment of any rights to claim under guarantee

The operating instruction must be kept close to the gearbox and must be available in case it is needed.

This operating instruction is written for V series gear units and is applicable only for V series. If any different type of gearbox is used please ask Dana Motion Systems Italia S.r.l. for the operating instructions of that type.

This instruction can be used only for standard type geared units of Dana Motion Systems Italia S.r.l.. For special application and modified gear units ask Dana Motion Systems Italia S.r.l. for validity.

This manual does not cover 94/9/EC compatible gearboxes. For 94/9/EC contact Dana Motion Systems Italia S.r.l..

3 UNIT DESIGNATION

3.1 DETAILED UNIT DESIGNATION

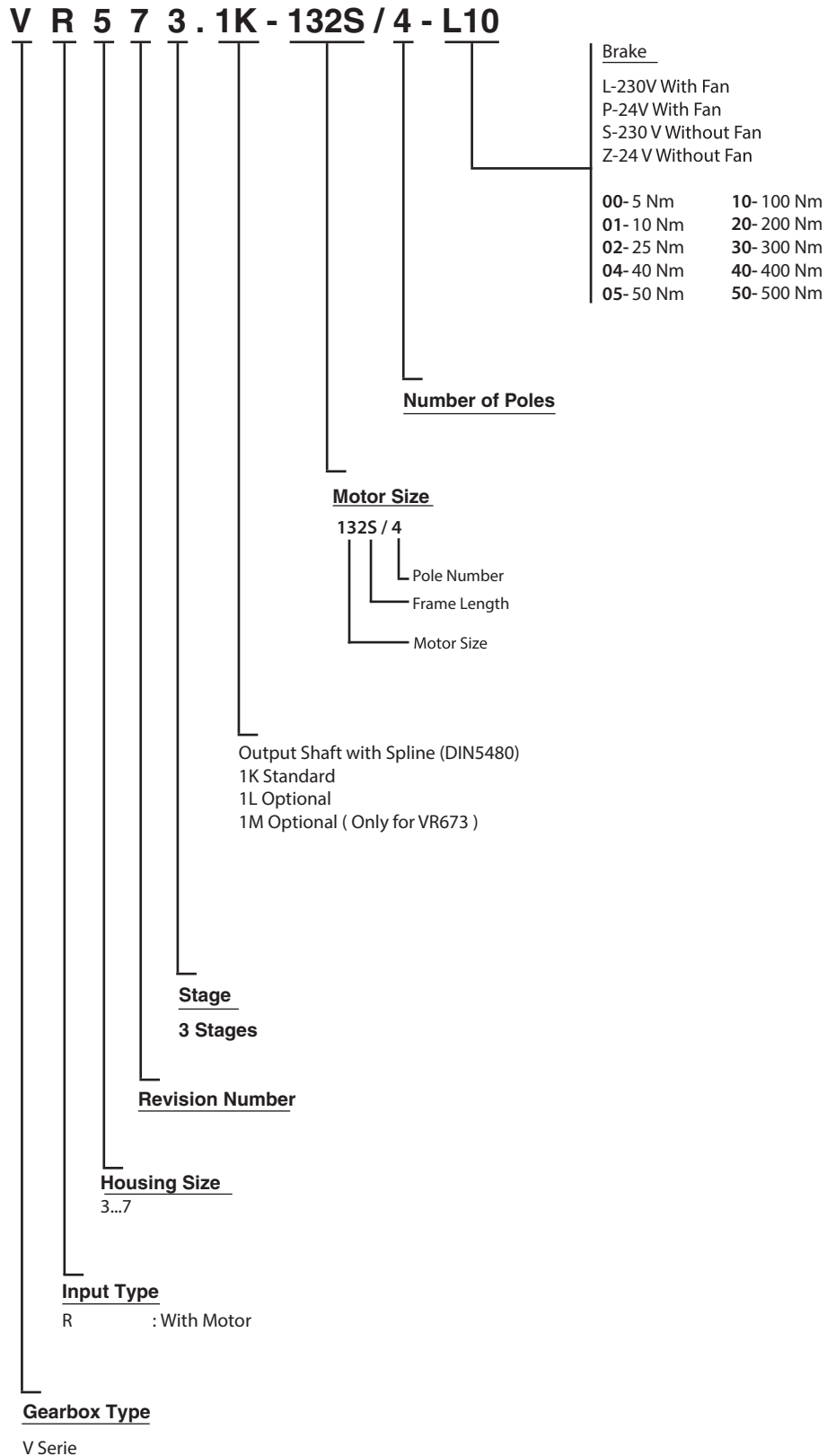

UNIT DESIGNATION

3.2 NAMEPLATE UNIT DESIGNATION

NOTE:

Nameplate unit designation is a short abbreviation from the detailed designation.

A sample name plate for V Series

			
Type: VR473.1K-112M/4-L05			
Serial N.: 100348988	M. Pos.: M5		
Power: 4 kW	Ratio: 61.85		
Oil: Min. VG 320 5 lt.	Speed: 23 rpm.		
Drum Dia.: 200 mm	Falls: 4/1		
Class.: 5 ton - M5(2m) / ISO4301(FEM1.001/III)			
⊕ Lift. Sp.: 3.6 m/min.	Brake: 50 Nm.	⊕	

Explanations:

Type: Unit designation

Serial N.: Serial number of the gearbox

M. Pos.: Mounting Position

Power: Motor Power

Ratio: Ratio of the gearbox

Oil: Type and quantity of the oil in the gearbox

Speed: Output speed of the gearbox

Drum Dia.: Diameter of the crane's drum

Falls: It is the ratio between the lifting speed and the tangential velocity of the rope at the point where it is wrapping to drum

Class: Class of the crane

Lift. Sp.: Crane's lifting speed

Brake: Brake torque

4 STANDARD TYPE GEARBOX PARTS LIST

4.1 V... TYPES

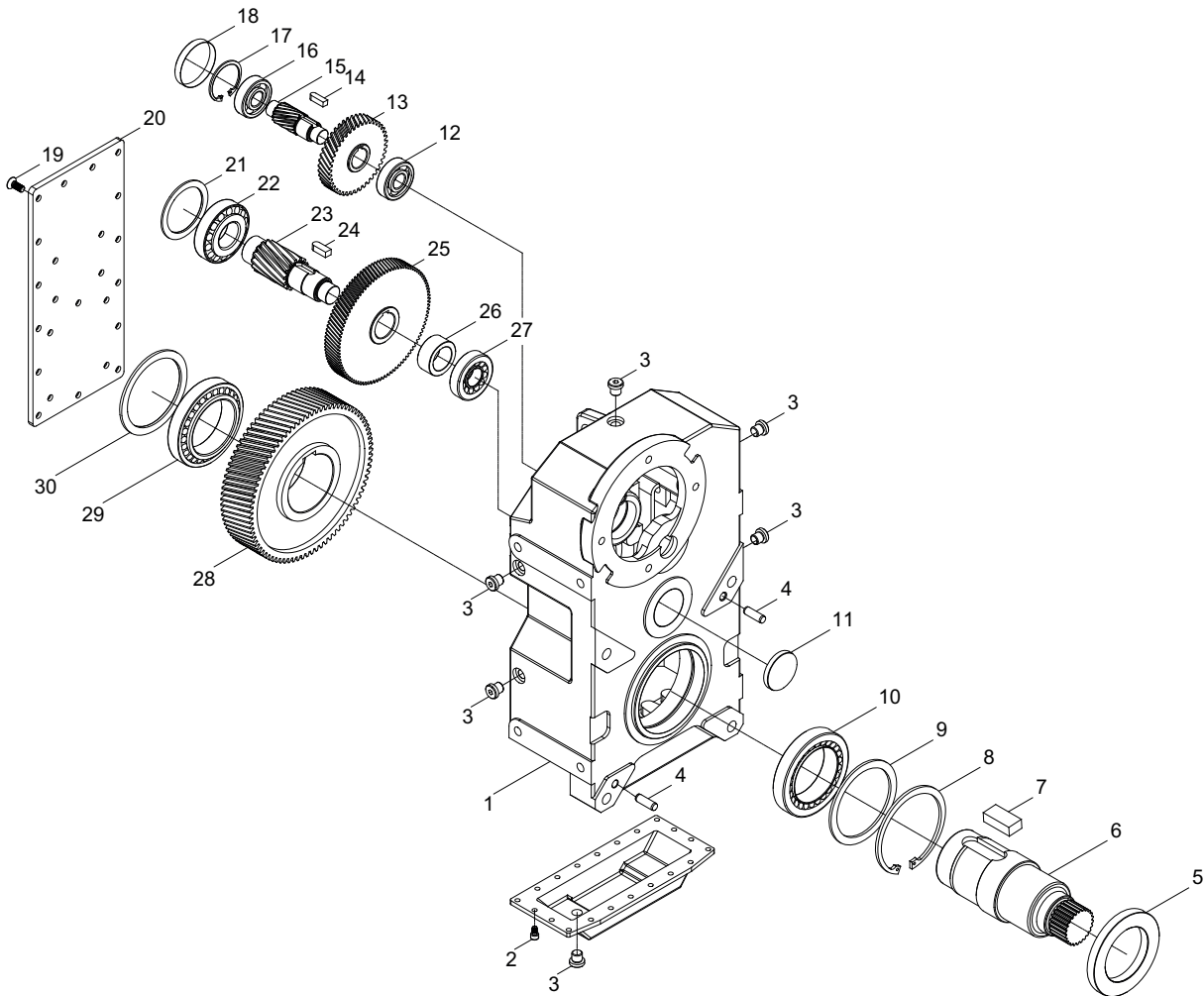

NOTE:

Standard V... type basic parts diagram. Parts may differ for special applications.

Standard Parts List	
1	Housing
2	Bolt
3	Plug
4	Screw Bolt
5	Seal
6	Output Shaft
7	Key
8	Washer
9	Spacer
10	Bearing

Standard Parts List	
11	Cover
12	Bearing
13	Gear
14	Key
15	Shaft Gear
16	Bearing
17	Washer
18	Tube
19	Bolt
20	Side Cover

Standard Parts List	
21	Spacer
22	Bearing
23	Shaft Gear
24	Key
25	Gear
26	Tube
27	Bearing
28	Gear
29	Bearing
30	Spacer

5 SAFETY

5.1 INTENDED USE

The gear reducer is designed for use in industrial machines. Please refer to our catalogue or our web page for the maximum permitted torques and speeds. The most important maximum permitted values are indicated on the nameplate of the product. But the whole data can be found on our product catalogues. Using the product out of the product catalogue / nameplate's permitted ranges will cancel the warranty/manufacturer declaration and Dana Motion Systems Italia S.r.l. will not take any responsibility.

The gear units are intended for industrial machines and may only be used in accordance with the information provided in this manual the product catalogue and the nameplate of the gearbox. They comply with the applicable standards and regulations and meet the requirements of the directive 2006/42/EC. The gearbox must be started up, maintained and operated according this manual. The gearbox must be incorporated with 2006/42/EC confirming parts/machines.

NOTE:

A motor connected to the gear unit is only allowed to be operated in the frequency entries so that the data provided on nameplate/catalogue of the gear unit is not exceeded and is accordance with the nameplate/catalogue. The speed range will be provided on the name plate if Dana Motion Systems Italia S.r.l. is informed that the gear unit will be used with frequency inverter. If not informed the nameplate will have a single fixed speed and only this speed is allowed. The electric motor and frequency inverter must be in accordance with 2006/42/EC.

NOTE:

If the gear units input is used with variable speed gear unit, this must be informed to Dana Motion Systems Italia S.r.l. before ordering and on the nameplate the allowed maximum and minimum speeds (speed range) will be provided. If not mentioned by ordering the gear units speed will be a fixed single input speed and only this speed is allowed.

NOTE:

If the gear unit will be driven by belt / coupling / chain drive etc. the gear unit is only allowed to be used according the nameplate/catalogue entries. Different speed, higher motor power, higher radial/axial loads etc. than nameplate/catalogue is not allowed.

NOTE:

The ambient temperature must be between +5 - +40 °C and no abrasive media must attack the paint and seals. If different working conditions this must be informed to Dana Motion Systems Italia S.r.l. before ordering. The gearbox maintenance (oil change / check) must be done according this manual.

5.2 IMPROPER USE

NOTE:

Every usage which exceeds the limits stated above, the nameplate and catalogue of the product (especially higher torques and speeds) is not compliant with the regulations, and thus prohibited.

The operation of the gear reducer is prohibited if:

- It was not mounted/installed according to regulations and this manual
- The gear reducer is very soiled
- It is operated without lubricant
- It is operated out of the permitted values provided on catalogues and/or nameplate.

5.3 SAFETY INSTRUCTIONS

5.3.1 GENERAL SAFETY INSTRUCTIONS

5.3.1.1 Working on the gear reducer

WARNING

Inappropriately executed work can lead to injury or damage.
Make sure that the gear reducer is only installed, maintained and dismantled by trained technicians.

WARNING

Foreign bodies spinning through the air can cause grave injury.
Before putting the gear reducer into operation, check that there are no foreign bodies or tools near the gear reducer

5.3.1.2 Operation

WARNING

Touching hot surfaces can lead to burns.
Do not touch the gear reducer if their operation temperatures are too high, or use suitable safety equipment like gloves.

WARNING

Rotating machinery can lead to injuries. There is danger of being trapped or pulled in!
Keep a sufficient distance and make safeguarding to rotating machinery. See relevant norms EN349+A1, EN13857.

5.3.1.3 Maintenance

WARNING

An unintentional start of the machine during maintenance work can lead to serious accidents.
Make sure no one can start the machine while you are working on it.

WARNING

Even a brief running of the machine during maintenance work can lead to accidents if the safety devices are not operating.
Make sure that all safety devices are mounted and active.

SAFETY

5.3.1.4 Lubricant

WARNING

Extended, intensive contact with oils can lead to skin irritations.
Avoid extended contact with oil, and clean oil off skin thoroughly.

WARNING

Hot oil can cause scalding.
When changing oil, protect yourself against contacting hot oil.

5.3.1.5 Ambient Conditions

DANGER

If the gear unit will be used in outdoor applications the gear unit must be prevented from rain snow and dust. Entering substances inside the gear unit from seals can damage the gear unit. Observe the safety instructions for outdoor use EN12100:2010.

WARNING

Standard gearboxes are allowed to work in ambient temperatures between +5 to +40°C unless differently specified on the nameplate. Using the gear unit out of this range can cause damage to the gear unit or environment. Over +40 °C ambient conditions the gear unit surface temp could be so high causing burns when touched.

5.4 TIGHTENING TORQUES

All screwed connections for which a tightening torque is specified, must on principle be tightened with a calibrated torque wrench and checked. Use the following torques for the threaded bores over the gear unit housing. For connecting elements refer to the mechanical installation part.

Table 3:

Bolt Size	Class	Tightening Torque [Nm]
M8	8.8	23
M10	8.8	43
M12	8.8	77
M16	8.8	190
M20	8.8	370
M24	8.8	640

5.5 CASE OF FIRE

The gear reducer itself is not combustible. However, it usually contains a synthetic or mineral gear oil. Please observe the following if the gear reducer is situated in a burning environment

5.5.1 SUITABLE EXTINGUISHING AGENTS, PROTECTIVE EQUIPMENT

Always keep suitable extinguishing, protective equipment like carbon dioxide, powder, foam, fog easily accessible around the gear unit.

WARNING

-High temperature produce irritating steam.
Use a protective breathing apparatuses.

5.5.2 UNSUITABLE EXTINGUISHING AGENTS

WARNING

Do not spray with water!

6 THINKS TO CHECK BEFORE THE GEAR UNIT OR GEARED MOTOR IS INSTALLED

NOTE:

If geared motors are used, please also refer to the manual of the motor manufacturer.

Before you install the gearbox you have to be sure that the gearbox is arrived with the all necessary equipment and without damage. Points to take into consideration before you start to install the unit;

- You have received the correct operation manual of the your product.
- The gearbox and all its parts are transported without damage.
- The gearbox is stored correctly according the instructions in this manual
- You have the latest product catalogue or you have access to our web page

6.1 TRANSPORTATION

When the goods arrive, first check for any damage. If some damage observed, immediately contact the transport company and inform about the damage. Contact Dana Motion Systems Italia S.r.l. for the damage and do not start to install the unit until it is agreed that the damage has no affect of operation.

DANGER

Falling or hard placement can damage the gear unit.

Only use hoisting and securing equipment which is permitted for the size / weight of your gear unit. Ensure that the load is slowly and carefully handled and placed.

DANGER



Use the supplied eyebolts or lifting holes for lifting up the gear unit. The eyebolts are capable to carry the weight of gearboxes only. Do not hang additional loads. Use suitable hoisting equipment which is capable to hold the gear units weight. Refer to the catalogue for various types weights. See drawing bellow for hoisting point.

DANGER

Do not stay beneath / under the lifting/hoisting equipment which may cause serious injuries by falling down objects, accidental movements, unexpected accidents.

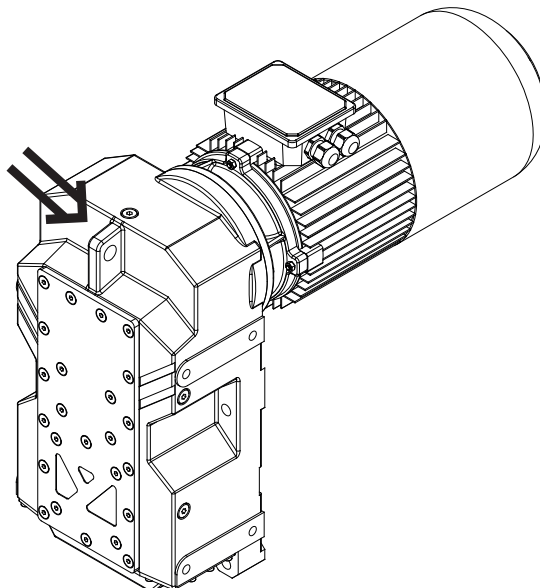

6.2 STORAGE

If the geared unit or geared motor will be stored up to 3 years refer to the following instructions;

With Packing;

Use corrosion protection oil for the output shaft and connection surfaces like flange surface or foot assembling surface. Seal the unit in a plastic wrap and pack it in container. A moisture indicator should be placed around the container to observe the moisture. Relative atmospheric humidity should not exceed 50%. The container should be kept under roof which protects from snow and rain. Under this condition the gear unit can be stored up to 3 year with regular check. The ambient temperature should be between -5 to 60 °C.

Without Packing;

Use protection oil for the output shaft and connection surfaces like flange surface or foot assembling surface. If no packing is used and the gearbox is stored without packing, the ambient temperature should be between 5 to 60 °C. The gearbox must be kept under enclosed roof with constant temperature and constant humidity not exceeding 50%. The storage should be free of dust and dirt and ventilated with filter. If the gearbox is stored without packing it is recommended not to store more than 2 years and regular check during this time is recommended.

If stored in open protect against insect damage.

7 INSTALLING THE GEAR UNIT

7.1 BEFORE YOU START

- Observe the gear unit for damages of storage or transportation. If any damage please contact Dana Motion Systems Italia S.r.l..
- Be sure that you have all the equipment necessary for installing like; Spanners, torque wrench, shims and distance rings, fixing devices for input and output elements, lubricant, bolt adhesive etc.

 NOTE:

This manual is not for 94/9/EC (ATEX) conforming gear units. For 94/9/EC conforming gear units refer to the ATEX range manual. ATEX conforming gear units have name plates indicating the zone and the temperature class and are different from standard type geared units. Therefore Standard units can not be installed on Potentially explosive atmospheres.

7.2 CHECK SPLINED SHAFT DIMENSIONS AND TOLERANCES

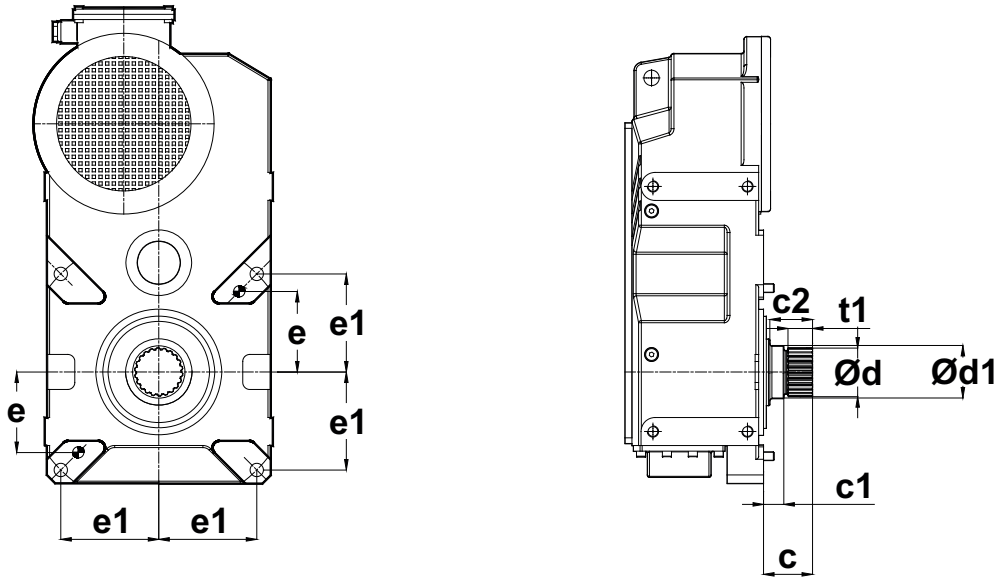

Table 4:

Type	Splined Shaft Dimensions						
	e	e1	c	c1 c2	d	d1	t1
V373.1K	75	90	55	22 48	W45x2x30x21x8f DIN5480	ø50 (h6)	28
V373.1L			50	22 43	W40x2x30x18x8f DIN5480	ø43 (h6)	23
V473.1K	95	110	60.5	27 51,5	W50x2x30x24x8f DIN5480	ø55 (h6)	28
V473.1L			48	16 42	W45x2x30x21x8f DIN5480	ø48 (h6)	27
V573.1K	115	140	69	28 61	W70x3x30x22x8f DIN5480	ø75 (h6)	35
V573.1L			56	16 51	W65x2x30x31x8f DIN5480	ø68 (h6)	35
V673.1K	132.5	157.5	84	32 74	W95x3x30x30x8f DIN5480	ø100 (h6)	45
V673.1L			67	17 60	W75x2x30x36x8f DIN5480	ø78 (h6)	44
V673.1M			75	21 68	W90x2x30x44x8f DIN5480	ø92 (h6)	45
V773.1K	160	187.5	110	35 97	W110x4x30x26x8f DIN5480	ø115 (h6)	67
V773.1L			97	21 89	W110x2x30x54x8f DIN5480	ø113 (h6)	67

INSTALLING THE GEAR UNIT

7.3 CHECK DRUM CONNECTION FLANGE (OPTIONAL) DIMENSIONS AND TOLERANCES

Table 5:

Type	Drum Connection Flange Dimensions
<p>V373 GN25.V37.FK</p>	<p>Ø138 Ø85 Ø50 R4 Ø41 Ø95 0 -0.02 18 +0.03 +0.01 15 19 50 N45x2x30x21x9H DIN5480</p>
<p>V473 GN25.V47.FK</p>	<p>Ø158 Ø95 Ø55 R5 Ø46 Ø110 0 -0.02 21 +0.03 +0.01 15 22 55 N50x2x30x24x9H DIN5480</p>
<p>V573 GN25.V57.FK</p>	<p>Ø198 Ø120 Ø75 R6 Ø64 Ø130 0 -0.02 24 +0.03 +0.01 15 30 65 N70x3x30x22x9H DIN5480</p>

7.4 CHECK THE AMBIENT TEMPERATURE

The ambient temperature must be between +5 °C to +40 °C for standard type gear units. If different contact Dana Motion Systems Italia S.r.l. for special solutions.

INSTALLING THE GEAR UNIT

7.5 CHECK THE VOLTAGE SUPPLY

The standard geared motors are supplied with 230/400 V 50/60 Hz up to 3 kW including 3 kW and 400/690 V 50/60 Hz over 3 kW and is indicated on the motors name plate unless it is differently ordered.

In case of only gear unit is supplied from Dana Motion Systems Italia S.r.l. please observe the name plate of the electric motor and the instructions of the supplier. Check the basic electric connection diagrams below. Use experienced electric technician.

⚠ DANGER

Using wrong connection or voltage can damage the electric motor or environment.

The following wiring diagram is for standard 230/400 V 50 Hz AC electric motors. For different voltages please contact Dana Motion Systems Italia S.r.l.. For gear units supplied without motor, refer to the motor manufacturers user manual.

⚠ DANGER



The electric connection must be done by experienced electric technician.

The gearbox, the motor and the brake must be grounded to prevent potential differences of earth and gearbox/motor.

Table 6:

Pole Number	Nominal Powers at 400V, 50Hz	
	230V (D) / 400 V (Y)	400V (D)
2 or 4	≤ 3 kW	≥ 4 kW
6	≤ 2,2 kW	≥ 3 kW
8	≤ 1,5 kW	≥ 2,2 kW
Starting Principle	Direct	Direct or Y/D

Basic motor connection wiring diagram

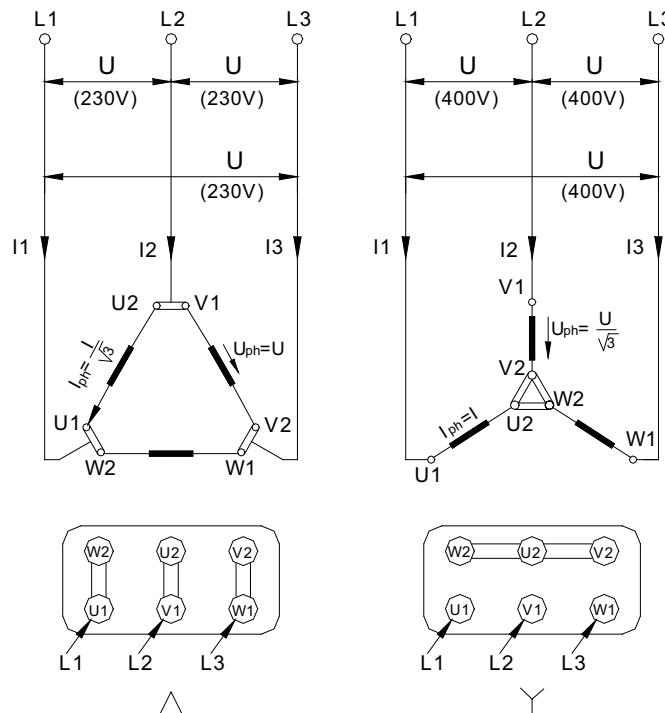

INSTALLING THE GEAR UNIT

Standard type brakes basic wiring diagram

⚠ DANGER



The electric connection must be done by experienced electric technician.

The gearbox and the motor must be grounded to prevent potential differences of earth and gearbox/motor.

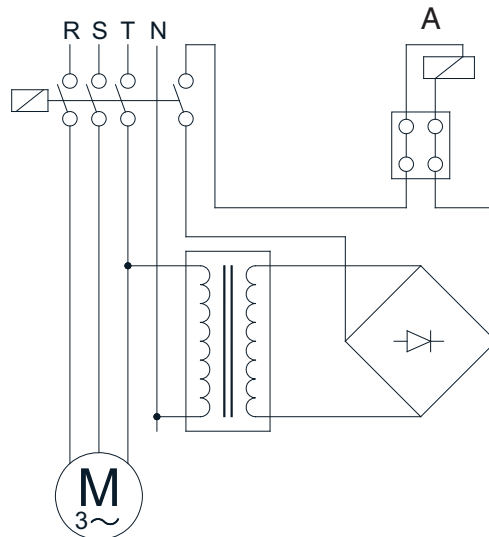
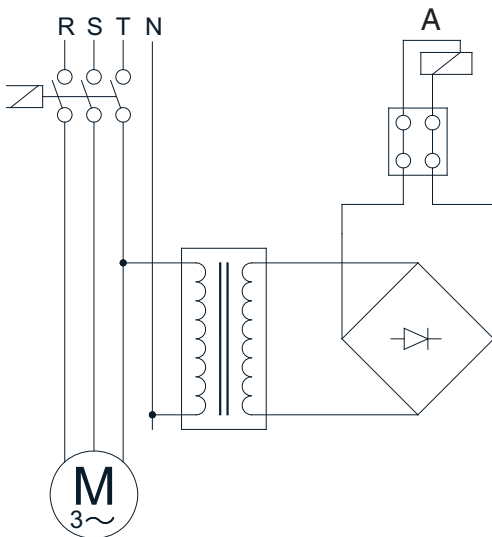
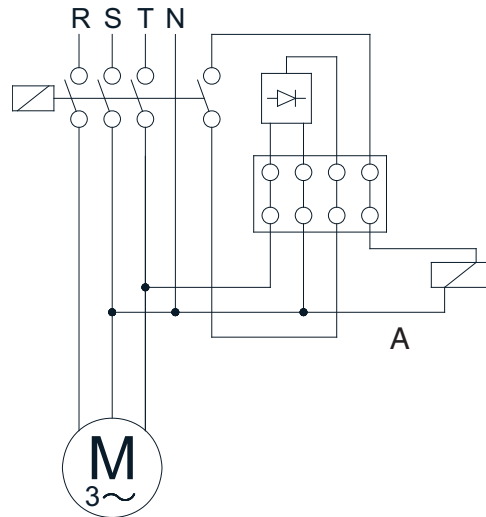
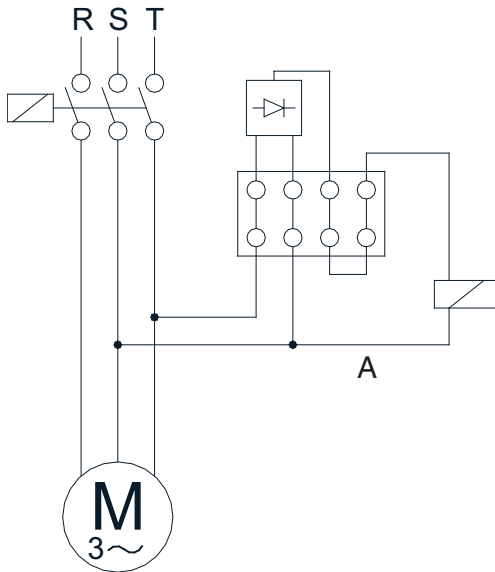

INSTALLING THE GEAR UNIT

7.6 CHECK THE MOUNTING POSITION

The mounting position must be in accordance with the mounting position mentioned on the name plate. If different please contact Dana Motion Systems Italia S.r.l. for possibilities of using in a different mounting position. Refer to the mounting positions and oil quantities on this manual and adjust the oil level accordingly with the recommended oil types given on this manual.

DANGER

Do not mix synthetic oils with mineral oils which can cause serious damage on the gear unit.

7.7 USE THE BREATHER PLUG

Breather plug is delivered with the gearbox together by Dana Motion Systems Italia S.r.l.. Breather plug must be on the top of the gearbox according to mounting position.

NOTE:

As shown in the label below, the transport protection rubber must be removed before operating the gear unit.

WARNING



TRANSPORT PROTECTION RUBBER

Remove the transport protection rubber before operating the gear unit.

Please read operation instructions before operating.

NOTE:

Some plug positions are not machined according mounting position. If no mounting position is mentioned by ordering, the standard M1 position plugs are machined.

7.8 CHECK THE OIL LEVEL

On the mounting position tables the oil level plug is shown. Please refer to those tables and be sure that the oil level is correct according the mounting position by screwing half way out the level plug and see if oil comes out from that plug. If oil comes out tighten the plug again. If no oil comes out take out the filling plug and add oil until oil comes out from the level plug and tighten both plugs after finish. Be sure you are using the correct oil mentioned on the oil tables on this manual.

DANGER

Do not mix synthetic oils with mineral which can cause serious damage on the gear unit.

7.9 CHECK SHAFT ENDS AND MOUNTING FACES

Before you start to installing be sure that all the connection elements are free of oil and dust. The output shaft may be protected by anti-corrosion oil. Please remove this using available solvents on your market. By using this do not touch sealing lips or painting of the housing.

INSTALLING THE GEAR UNIT

7.10 COVER ABRASIVE AMBIENT

If the gear unit will be placed on a abrasive ambient be sure that the output seals are covered so that no abrasive material, chemicals or water touches the seals. Any pressure coming from outside over the seals can cause that the out staying substances to enter the gearbox and cause serious damage to the gear unit. If pressure or abrasive material can not be prevented from coming over the sealing, contact Dana Motion Systems Italia S.r.l. for solutions.

DANGER

Abrasive material, chemicals, water, positive or negative pressure exceeding 0,2 bar can affect or damage the sealing lip or output shaft. Inside entering substances from the seals can cause serious damage to the gear unit.

7.11 CHECK ACCESSIBILITY TO FILLING, BREATHER AND DRAIN PLUGS

The filling, breather and drain plugs must be freely accessible for further checking and service.

8 MECHANICAL INSTALLATION

The gear unit can only be installed using the supplied connection points like foot and flange assembling points.

DANGER

To install the gear unit without the supplied connection points can cause serious injuries by loosening or braking the gear unit. Even the gear unit is installed totally correctly according this manual, be sure that no one will be harmed by accidentally brake downs or loosening.

- The mounting plate must be rigid enough not allowing torsions, flat enough to prevent strains by tightening the bolts and stable enough not allowing vibrations.
- By using chain drives this becomes much more important because of the polygon effect on chain drives.
- According to your connection elements the maximal permitted radial and axial load of the gear unit must be in accordance with your application.
- Check the product catalogue for permitted radial loads and calculation.

WARNING

If the output or input shaft is overloaded by radial or axial loads it can cause serious damage to the gear unit.

Secure the gear unit using 8.8 or higher quality bolts.

DANGER



Cover all the turning parts from human entering or touching. Turning parts can cause severe or fatal injuries.

CAUTION

For different kind of basic installations refer to the following illustrations.

MECHANICAL INSTALLATION

8.1 FITTING OUTPUT SHAFT ELEMENTS

Use the following illustration to assemble output shaft units

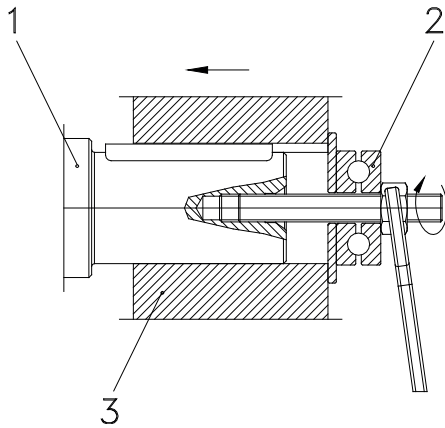

- 1 - Shaft
- 2 - Bearing
- 3 - Coupling Hub

8.2 CORRECT POSITION OF OUTPUT SHAFT ELEMENTS

The Output Shaft unit (transmission elements) must be placed as close as possible to the gear unit so that the radial load is as close as possible to the gear unit.

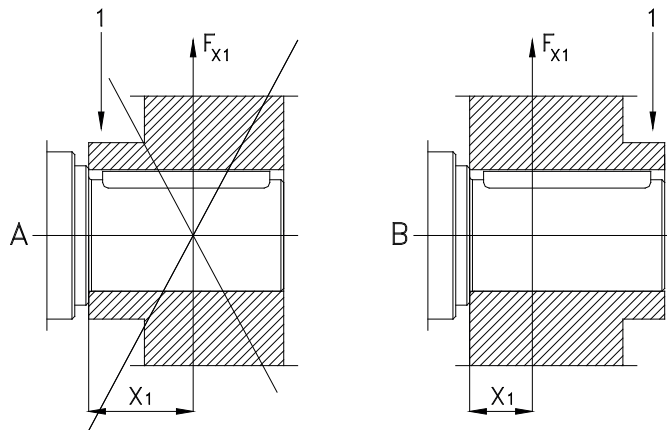

- 1 - Hub

8.3 FITTING COUPLINGS

By fitting couplings be sure that there is some clearance between the two elements

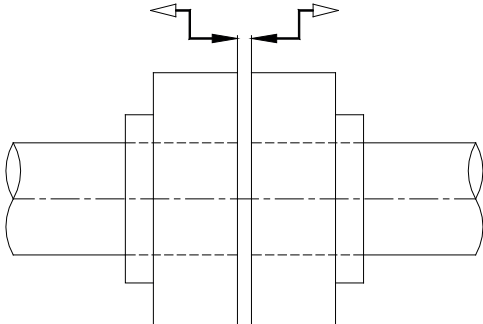

By fitting couplings be sure that there is no eccentricity between the two shafts.

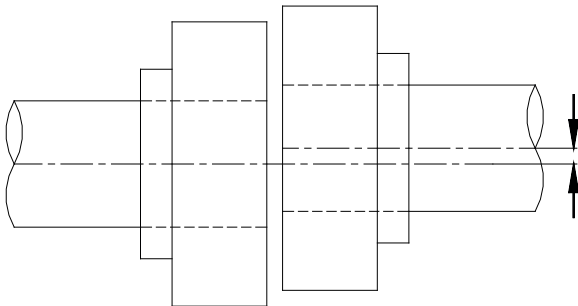

By fitting couplings be sure that the two shafts are not angular miss-aligned

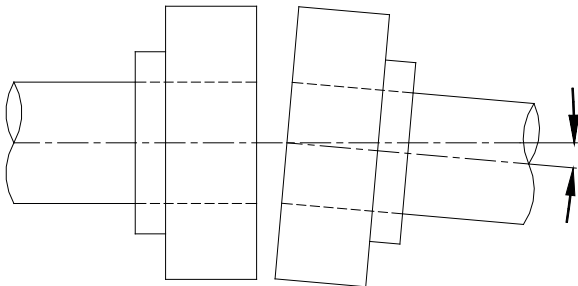

9 MAINTENANCE & INSPECTION

Under normal ambient and working conditions the gear unit should be checked according the following intervals. (For definition of normal working conditions refer to the product catalogue: "Selecting Gearbox" section);

Table 7:

Item to check /replace	Every 3.000 working hours or every 6 months	Every 4.000 working hours	Every 10.000 working hours or every 3 years	Every 25.000 working hours
Check for oil leakage	x			
Check for oil level	x			
Check oil leakage from seal	x			
Check Rubber buffer	x (Change if necessary)			
Check Bearings Noise		x (Change if necessary)		
Change Mineral Oil			x (See Below for details)	
Change Synthetic-PAO Oil				x (See Below for details)
Change Sealing				x
Change Bearing Grease				x
Change Bearings				x
Check for noise Changes				x

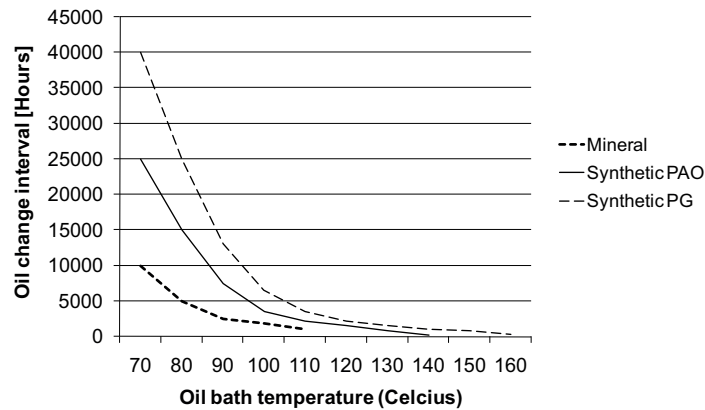

NOTE:

For normal ambient conditions 70 °C oil bath temperature should be taken as reference

* For V series Mineral oil is used unless it is differently ordered. For oil type and quantities refer to the following tables.







10 LUBRICATION

10.1 OIL TYPES

Table 8:

Lubricant	DIN 51517-3	Ambient Temperature [°C]		ISO VG	Aral	Beyond Petroleum	Castrol	Klüber Lubrication	Mobil	Shell	Total
		Dip Lubrication	Forced Lubrication								
Mineral Oil	CLP	0 ... +50	-	680	Degol BG 680	Energol GR-XP 680	Alpha SP 680	Klüberoil GEM 1-680 N	Mobilgear XMP 680	Omala 680	Carter EP 680
		-5 ... +45	-	460	Degol BG 460	Energol GR-XP 460	Alpha SP 460	Klüberoil GEM 1-460 N	Mobilgear XMP 460	Omala F460	Carter EP 460
		-10 ... +40	+15 ... +40	320	Degol BG 320	Energol GR-XP 320	Alpha SP 320	Klüberoil GEM 1-320 N	Mobilgear XMP 320	Omala F320	Carter EP 320
		-15 ... +30	+10 ... +30	220	Degol BG 220	Energol GR-XP 220	Alpha SP 220	Klüberoil GEM 1-220 N	Mobilgear XMP 220	Omala F220	Carter EP 220
		-20 ... +20	+5 ... +20	150	Degol BG 150	Energol GR-XP 150	Alpha SP 150	Klüberoil GEM 1-150 N	Mobilgear XMP 150	Omala 150	Carter EP 150
		-25 ... +10	+3 ... +10	100	Degol BG 100	Energol GR-XP 100	Alpha SP 100	Klüberoil GEM 1-100 N	-	Omala 100	Carter EP 100
Synthetic Oil	CLP PG	-10 ... +60	-	680	Degol GS 680	Energyn SG-XP 680	-	Klüber-synth GH 6-680	Mobil Glygoyle 680	Tivela S 680	Carter SY 680
		-20 ... +50	-	460	Degol GS 460	Energyn SG-XP 460	Aphasyn PG 460	Klüber-synth GH 6-460	Mobil Glygoyle 460	Tivela S 460	Carter SY 460
		-25 ... +40	+5 ... +40	320	Degol GS 320	Energyn SG-XP 320	Aphasyn PG 320	Klüber-synth GH 6-320	Mobil Glygoyle 320	Tivela S 320	Carter SY 320
		-30 ... +30	0 ... +30	220	Degol GS 220	Energyn SG-XP 220	Aphasyn PG 220	Klüber-synth GH 6-220	-	Tivela S 220	Carter SY 220
		-35 ... +20	-5 ... +20	150	Degol GS 150	Energyn SG-XP 150	Aphasyn PG 150	Klüber-synth GH 6-150	-	Tivela S 150	Carter SY 150
		-40 ... +10	-8 ... +10	100	-	-	-	Klüber-synth GH 6-100	-	-	-
	CLP HC	-10 ... +60	-	680	-	-	-	Klüber-synth GEM 4-680 N	Mobilgear SHC XMP 680	-	Carter SH 680
		-20 ... +50	-	460	Degol PAS 460	Energyn EP-XF 460	Alphasyn T 460	Klüber-synth GEM 4-460 N	Mobilgear SHC XMP 460	Omala HD 460	Carter SH 460
		-25 ... +40	+5 ... +40	320	Degol PAS 320	Energyn EP-XF 320	Alphasyn T 320	Klüber-synth GEM 4-320 N	Mobilgear SHC XMP 320	Omala HD 320	Carter SH 320
		-30 ... +30	0 ... +30	220	Degol PAS 220	Energyn EP-XF 220	Alphasyn T 220	Klüber-synth GEM 4-220 N	Mobilgear SHC XMP 220	Omala HD 220	Carter SH 220
		-35 ... +20	-5 ... +20	150	Degol PAS 150	Energyn EP-XF 150	Alphasyn T 150	Klüber-synth GEM 4-150 N	Mobilgear SHC XMP 150	Omala HD 150	Carter SH 150
		-40 ... +10	-8 ... +10	100	-	-	-	Klüber-synth GEM 4-100 N	-	-	-

LUBRICATION

Lubricant	DIN 51517-3	Ambient Temperature [°C]		ISO VG	Aral	Beyond Petro- leum	Castrol	Klüber Lubrica- tion	Mobil	Shell	Total
		Dip Lubri- cation	Forced Lubrica- tion								
Food Grade Oil	CLP NSF H1	-15 ... +25	+5 ... +25	220	-	-	Optileb GT 220	Klüberoil 4 UH1-220 N	Mobil SHC Cibus 220	Cassida Fluid GL- 220	Nevastane SL 220
Biodegra- dable Oil	CLP E	-25 ... +40	+5 ... +40	320	-	-	Tribol Bio- Top 1418- 320	Klüber- synth GEM 2-320	-	-	Carter Bio 320
Mineral Grease [-20 +120 Working Temperature °C]					Aralub HL3	Energrea- se LS 3	Speherol AP3	Centoplex 2 EP	Mobilux EP 3	Alvania RL3	Multis Complex EP 2
Synthetic Grease [-30 +100 Working Temperature °C]					-	Energrea- se SY 2202	-	Petamo GHY 133 N	Mobiltemp SHC 100	Cassida RLS 2	Multis Complex SHD 220

10.2 CHANGING THE OIL

Refer to the nameplate to find out the correct oil filled inside the gearbox.

Do not mix synthetic oils with mineral oils which will cause serious damage to the gear unit. The oil change must be done by using the filling, draining and level plugs according the mounting position illustrated in section "Oil Levels,Plugs and Quantities" page 29.

WARNING

Extended, intensive contact with oils can lead to skin irritations.
Avoid extended contact with oil, and clean oil off skin thorough.

WARNING

Hot oil can cause scalding.
When changing oil, protect yourself against contacting hot oil.

10.3 OIL LEVELS, PLUGS AND QUANTITIES

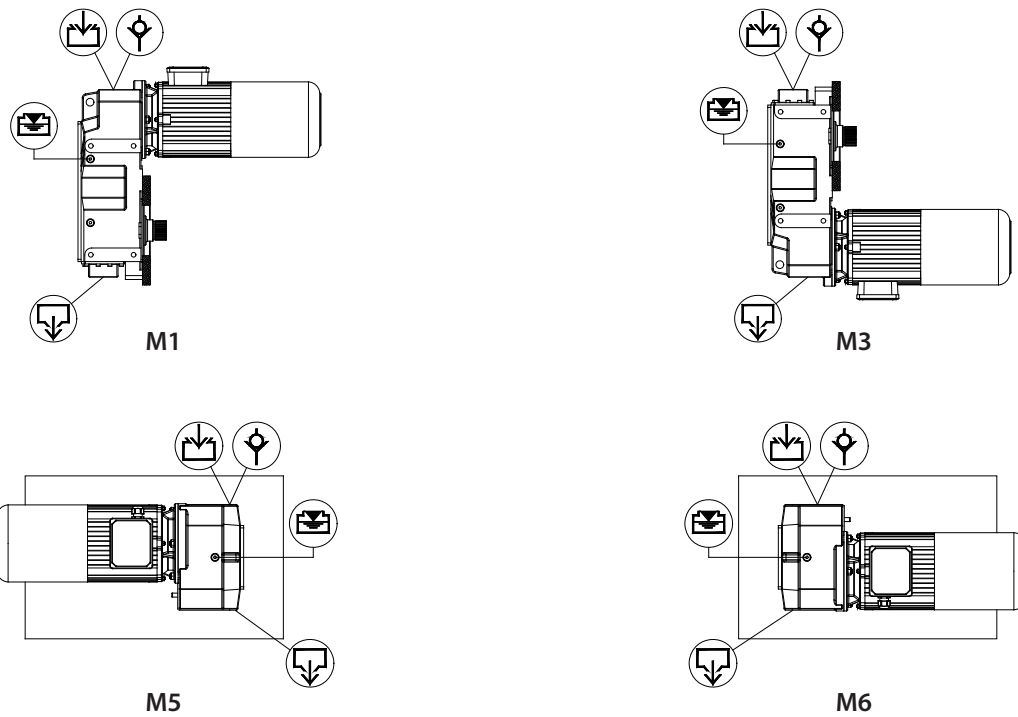

Table 9:

Symbols:							
	Drain Plug		Oil Filling		Vent Plug		Oil Level

Oil Quantities (lt)

Table 10:

Tip	V Series Oil Quantities (lt)			
	M1	M3	M5	M6
V373	3,3	2,6	2,6	2,5
V473	4,5	4,1	4,3	4,1
V573	9,7	7,9	9,2	9,0
V673	16,3	13,6	16	15,8
V773	30	18	21	20,7

LUBRICATION

10.4 MOUNTING POSITIONS

V Series

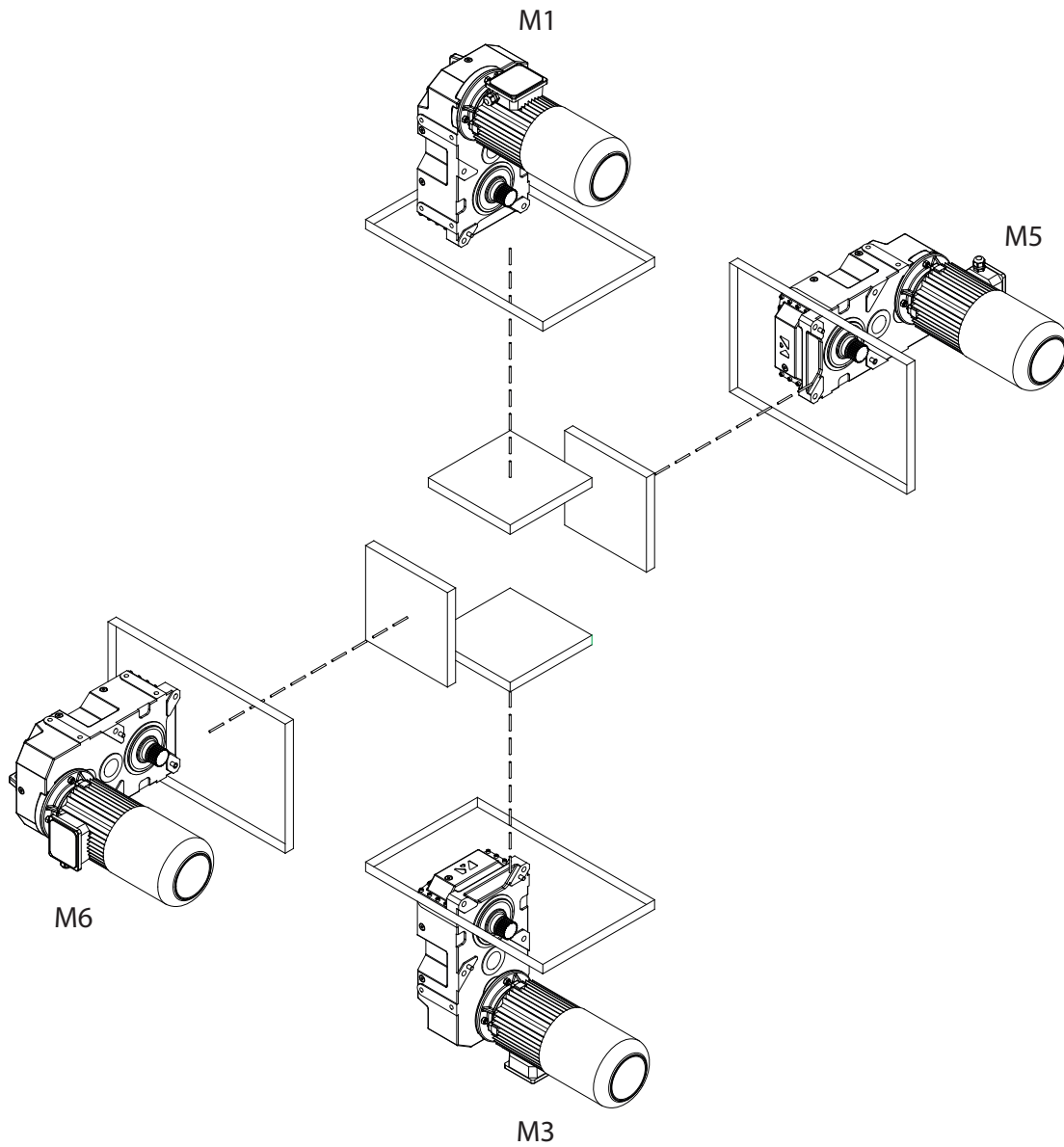

Indicated mounting positions are determined as reference directional position of the gearbox.
Mounting surfaces are not binding.

11 TROUBLESHOOTING GUIDE

WARNING

All the operations below must be done by authorized and skilled mechanic/electrician.
 Inform Dana Motion Systems Italia S.r.l. before making any change to the gearbox. Only oil change is allowed to change without information. Do not make any think if you are not sure what you are doing and contact Dana Motion Systems Italia S.r.l.. Any change or operation done without the information of Dana Motion Systems Italia S.r.l. is in your own risk and responsibility and Dana Motion Systems Italia S.r.l. does not take any responsibility.

Table 11:

ID	Problem	Observation	Remedy
001	Gearbox Does Not Start Up	You hear no noise and shaft is not turning. You are not using any driver or frequency inverter.	Please Check the voltage supply and frequency of your electric connection. They must be in accordance with the nameplate of the motor. Observe motor manufacturers start up manual. Still does not work go to ID 100
002	Gearbox Does Not Start Up	You hear no noise and shaft is not turning. You are using frequency inverter or driver.	Please observe the frequency inverter/driver manual. Check the motor by supplying direct voltage to see if the problem is on your driver/frequency inverter. Still does not work go to ID 001.
003	Gearbox Does Not Start Up	You hear some noise but both motor shaft and gearbox shaft is not turning. You are not using any driver /frequency inverter or braked motor.	Please Check the voltage supply and frequency of your electric connection. They must be in accordance with the nameplate of the motor. Observe motor manufacturers start up manual. Still same problem, the load may be too high for the chosen motor. Loosen the gearbox from the load/torque. If it works than the starting torque is insufficient and higher motor power is needed. For monophase motors, check the starting up condansator and running condansator as well. If notting helps go to ID 100
004	Gearbox Does Not Start Up	You hear some noise but both motor shaft and gearbox shaft is not turning. You are using driver or frequency inverter.	Please observe the frequency inverters or drivers manual. To see if the problem is on your driver or frequency inverter take out the driver/frequency inverter and make direct voltage supply to the motor according the motors nameplate. Still does not work go to ID 100
005	Gearbox Does Not Start Up	You hear some noise but both motor shaft and gearbox shaft is not turning. You are using braked motor	Please Check the voltage supply and frequency of your electric connection. They must be in accordance with the nameplate of the motor. Observe motor manufacturers start up manual. Be sure that the brake is working. Observe the brake manufacturers manuel. If brake is supplied from Dana Motion Systems Italia S.r.l. observe this manuel for correct brake wiring diagram. If still not work supply the brake with voltage according its nameplate directly. For example 198V DC. You will hear a clicking noise explaining that the brake is opening. If you hear no noise the brake or rectifier is defect. If you hear the clicking noise the brake is working. You should this clicking noise by your normal electric connection as well. By supplying direct supply to the brake you hear the clicking noise and at same time you supply the motor with direct voltage according to its name plate and still same problem, the load may be too high for the chosen motor. Goto ID 003.
006	Gearbox Does Not Work in Low Speeds/frequencies.	You are using frequency inverter.	For very low speeds the frequency inverters frequency is lowering down. For very low frequencies the inverter parameter and motor parameter must be optimized. Also for low speeds the efficiency of the gearbox may vary too much. Specially for worm-gearboxes. The recommended frequency range is 20-70 Hz for worm-gearboxes and 10-70 Hz for Helical Gear Boxes. Use Higher motor power and Frequency inverter or change ratio of gearbox to work inside the recommended range.
007	Gearbox Does Not Start Mornings or After Long Time Stop.	Ambient Temperature is below +5 Celsius	The oil is not in accordance with your working conditions. Change to lower viscosity oils. Observe this manual for using the correct oil. Working in higher ambient temperatures is an other solution if possible. If still same problem you need higher motor power.

TROUBLESHOOTING GUIDE

ID	Problem	Observation	Remedy
008	Gearbox is Heating Up too Much	You are using Worm Gear Box and ambient temp is lower than +40 Celsius	Measure the surface temp. using a temperature measuring device under full load. If the temp is under +80 Celsius this will make no harm to the gearbox and is normal. All ATEX conforming gearboxes and standart worm gearboxes are designed to work under max. +120 Celsius. If higher than +120 Celsius and using ATEX conforming gear box immediatly stop the system and contact Dana Motion Systems Italia S.r.l.. Go to ID 100. If not ATEX conforming check the oil type and oil quantity/level according your mounting position and check the nameplate mounting position. If nameplate mounting position does not fit the actual position goto ID 100.
009	Gearbox is Heating Up too Much	You are using Helical Gear Box. Ambient temp is lower than +40 Celsius	Measure the surface temp. using a temperature measuring device under full load. If the temp is under +80 Celsius this will make no harm to the gearbox and is normal. All ATEX conforming gearboxes are designed to work under max. +120 Celsius. If higher than +120 Celsius and using ATEX conforming gear box immediatly stop the system and contact Dana Motion Systems Italia S.r.l.. If not ATEX gearbox the gearbox is designed to work under max. +80 Celsius. If higher than +80 Celsius check the oil type and oil quantity/level according your mounting position and check the nameplate mounting position. If nameplate mounting position does not fit the actual position goto ID 100
010	Gearbox is Heating Up too Much	Ambient Temp is over +40 Celsius	Standart Gearboxes are designed to work under +40 Celsius. ambient temperature. If ambient temp is higher than +40 Celsius special solutions/gearboxes are required. Please contact Dana Motion Systems Italia S.r.l..
011	Gearbox is noisy	Noise is regular continious	Check Your moving parts for noise. Disassemble the gearbox and run without load. If you still hear the noise motor bearings or gearbox bearings are defect. Change bearings. Goto ID 100
012	Gearbox is noisy	Noise is random	Check Your moving parts for noise. Disassemble the gearbox and run without load. If you hear still the noise the oil may has some particles inside. Change the oil and look for small particles. If metal particles are found the gearbox may have some damage. Goto ID 100
013	Gearbox is noisy	Regular knocking noise	Check Your moving parts for noise. Disassemble the gearbox and run without load. If you still hear the noise one of the gears inside is defect. Goto ID 100
014	Gearbox is noisy	Regular up and down noise	Check the output-shaft connection alements for runout. Take out the output shaft element and run without load. If you still hear the noise one of the gears has runout problem. Goto ID 100
015	Gearbox is noisy	Gearbox is with braked motor and noise is comming from the brake side randomly.	Low randomly clicking noise may come from the brake disk which is normal. If noise level is disturbing the brake may be defect or brake clearance is not adjusted. Goto ID 100
016	Gearbox is noisy	You are using frequency inverter and the noise level is changing according your speed.	The frequency inverter parameters are not optimized for the frequency range or motor you are using. Observe the frequency inverters manual. If still same problem change the ratio of gearbox. Goto ID 100
017	Oil is Leaking	Oil Leakage from Seal	If ambient Temp is over +40 Celsius or none stop work over 16 hours please change the top plug with a breather plug. Observe this manual for using breather plug. If this is not your case the seal could be damaged. Goto ID 100
018	Oil is Leaking	Oil Leakage from Plug	If you are using breather plug be sure it is in the correct place. This is the most top plug position according your mounting position. The plug may be not tight enough. There are some particles under the plug rubber surface. Clean and tiftgen the plug. If still same problem goto ID 100

TROUBLESHOOTING GUIDE

ID	Problem	Observation	Remedy
019	Oil is Leaking	Oil Leakage from Housing	Observe exactly where the oil is coming out. It could be seal or plug point where it comes out and leaks over the housing. If this is your case goto ID 018/019. If you are sure oil comes out from housing than housing has some micro split / crack. Goto ID 100
020	Oil is Leaking	Oil Leakage from Cover	The sealing liquid under cover is split/defect. Disassemble the cover and put new sealing liquid. Assemble the cover and tighten the bolts. If still same problem goto ID 100
021	Gearbox is moving regularly on its mounting point	You are using Torque Arm	The movement of gear box is because of the runout of the shaft which you assemble the gearbox. This has no bad affect or harm to the gearbox and is normal unless you are using torque arm.
022	Gearbox is moving randomly on its mounting point	You are using Torque Arm	The movement of gear box is because of the runout and clearance of the shaft which you assemble the gearbox. Check the clearance of the assembling shaft and the clearances on your machine. This has no bad affect or harm to the gearbox unless you are using torque arm.
023	Motor is heating up	Motor is running over its nominal current	The motor power is not enough or some overload to the motor is possible. The motor may be defect. Goto ID 100
023	Motor is heating up	Ambient is dusty	Check the motor Fan Hub and ribs. They must be free of dust. If you are using forced external fan, check if it is working. If you are using frequency inverter in low speeds and you do not have forced external fan, you may need forced external fan. Goto ID 100
024	Motor is running but Gearbox shaft does not turn	Scratchinh noise comes out	Some part (key, gear) may be defect inside gearbox. Goto ID 10
025	Gearbox Housing is Defect	You are using chain drive or pinion gear	The radial load or polygon effect of the chain may have caused the damage. Check also if the assembly bolts are loosened or the plate you assemble the gearbox is right enough. Check if you are using the correct diameter of chain drive and you are not exceeding max. allowed radial load. Check the position of your output element and re-calculate your radial load and check if this fit to the maximum allowed radial load. Goto ID 100
026	Output Shaft is Defect	You are using chain drive or pinion gear	The radial load or polygon effect of the chain may have caused the damage. Check also if the assembly bolts are loosened or the plate you assemble the gearbox is right enough. Check if you are using the correct diameter of chain drive and you are not exceeding max. allowed radial load. Check the position of your output element and re-calculate your radial load and check if this fit to the maximum allowed radial load. Goto ID 100
027	Gearbox is stopping too late	You are using braked motor	Please check the wiring diagram of the brake. There are two different kind of brake wiring diagram. The standart gearbox delivered from our factory is set to delayed braking. For sudden braking check the wiring diagram.
028	Gearbox is starting too late	You are using braked motor	For fast opening of big brakes (over 100Nm), you may need shock transformers which is supplied by Dana Motion Systems Italia S.r.l.. Goto ID 100
100	Service Required	No self solution found	Please contact Dana Motion Systems Italia S.r.l. Service point. See on the back side of this manual. Changing mechanical parts of gearbox can only be done by Dana Motion Systems Italia S.r.l. or with information of Dana Motion Systems Italia S.r.l.. Any change without informing Dana Motion Systems Italia S.r.l. will cancel the warranty, manufacturer declaration and Dana Motion Systems Italia S.r.l. will take no responsibility.

12 DISPOSAL

If your product is no longer of use and you wish to dispose of it, refer to the instructions here. If you have any questions regarding ecological disposal methods, please consult our service points given on the backside of this manual.

12.1 DISPOSAL OF OIL

Lubricants (oil and greases) are hazardous substances, which can contaminate soil and water. Collect drained lubricant into suitable receptacles and dispose of it according to the valid national guidelines.

12.2 DISPOSAL OF SEALING

Remove the sealing rings from the gear reducer, and clean them of oil and grease residues. Dispose of the sealings as composite material (metal/plastic)

12.3 DISPOSAL OF METAL

Divide up the remainder of the gear reducer into iron, aluminium, non-ferrous heavy metal if possible. Dispose of it according to the valid national guidelines.

© Copyright 2022 Dana Incorporated
All content is subject to copyright by Dana and may not be reproduced in whole or in part by any means, electronic or otherwise, without prior written approval. THIS INFORMATION IS NOT INTENDED FOR SALE OR RESALE, AND THIS NOTICE MUST REMAIN ON ALL COPIES.

For product inquiries or support, visit www.dana.com.
For other service publications, visit www.danaaftermarket.com/literature-library
For online service parts ordering, visit www.danaaftermarket.com



BREVINI[®]

Motion Systems



1800-OILSOL <https://oilsolutions.com.au/>
1800-645765

sales@oilsolutions.com.au