



**BREVINI<sup>®</sup>**

*Motion Systems*



1800-OILSOL  
1800-645765

<https://oilsolutions.com.au/>

[sales@oilsolutions.com.au](mailto:sales@oilsolutions.com.au)

## DIRECT CURRENT MOTORS

**Technical Catalogue**

March  
**2020**

*web edition*

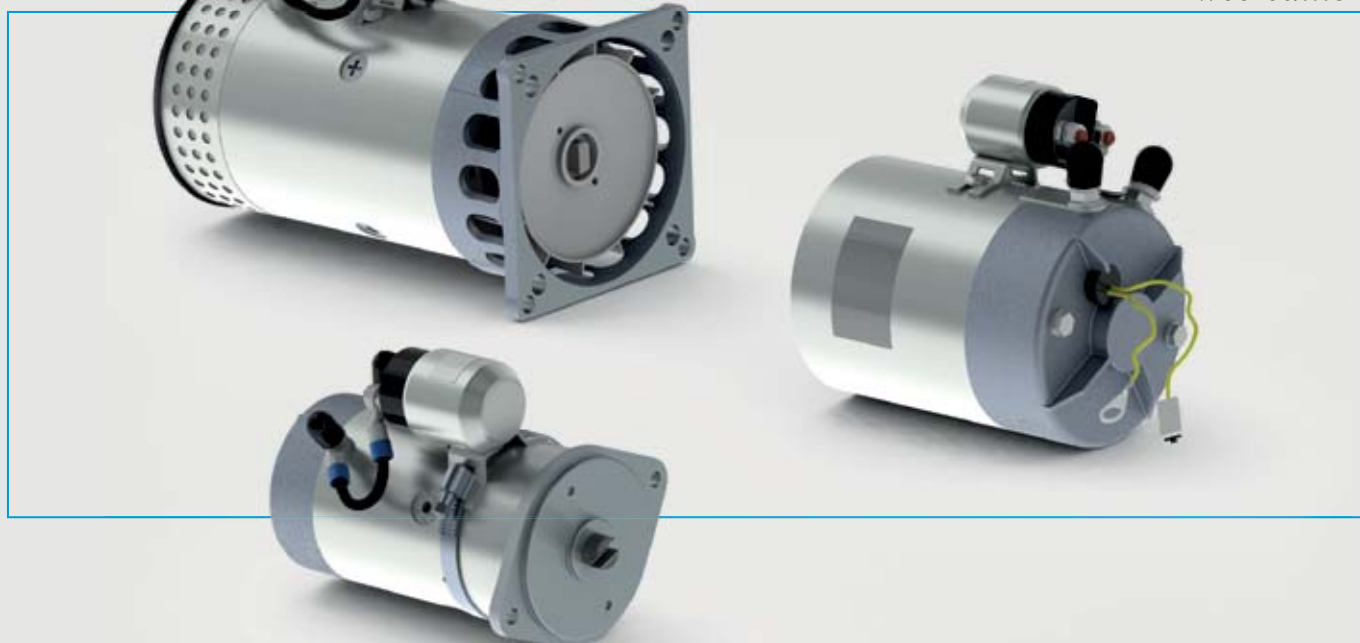



## DC motors

Description	Type	Page
Introducion		2
12V DC - 0.35 kW - D.80	<b>25021400</b>	4
24V DC - 0.4 kW - D.80	<b>25021500</b>	6
12V DC - 0.5 kW - D.80	<b>25024200</b>	8
24V DC - 0.5 kW - D.80	<b>25024300</b>	10
12V DC - 0.7 kW - D.80	<b>25021600</b>	12
24V DC - 0.8 kW - D.80	<b>25021700</b>	14
12V DC - 1.6 kW - D.115	<b>25021100</b>	16
24V DC - 2.2 kW - D.115	<b>25021200</b>	18
12V DC - 1.5 kW - D.115	<b>25022200</b>	20
12V DC - 1.5 kW - D.115	<b>25022200 FAN</b>	22
24V DC - 2.0 kW - D.115	<b>25022300</b>	24
24V DC - 2.0 kW - D.115	<b>25022300 FAN</b>	26
12V DC - 1.6 kW - D.115	<b>25022000</b>	28
24V DC - 2.2 kW - D.115	<b>25022100</b>	30
12V DC - 1,6 kW - D.115	<b>25022600</b>	32
24V DC - 2,2 kW - D.115	<b>25022700</b>	34
24V DC - 3.0 kW - D.125	<b>25021300</b>	36
24V DC - 3.0 kW - D.125	<b>25021300 FAN</b>	38
24V DC - 3.0 kW - D.125	<b>25022400</b>	40
24V DC - 3.0 kW - D.125	<b>25022400 FAN</b>	42
Starting switch 120A		44
Starting switch 150A		44

© 2020 Dana Motion Systems Italia S.r.l. all rights reserved. Hydr-App, SAM Hydraulik, Aron, Brevini Hydraulics, BPE Electronics, VPS Brevini, OT Oiltechnology, logos are trademarks or are registered trademarks of Dana Motion Systems Italia S.r.l. or other companies Dana in Italy and other countries.

The technical features supplied in this catalogue are non binding and no legal action can be taken against such material. Dana will not be held responsible for information and specifications which may lead to error or incorrect interpretations. Given the continuous technical research aimed at improved technical features of our products, Dana reserves the right to make change that are considered appropriate without any prior notice. This catalogue cannot be reproduced (in whole or in part) without the prior written consent of Dana. This catalogue supersedes all previous ones.

Use of the products in this catalogue must comply with the operating limits given in the technical specifications. The type of application and operating conditions must be assessed as normal or in malfunction in order to avoid endangering the safety of people and/or items.

# Introduction

This collection of technical tables lists all the DC motors approved by Dana and used in power units of its standard production. Dana offers a wide range of DC motors with rated voltage from 12 V to 24 V and power from 350 W to 3000 W. The diagrams shown are determined from tests performed with the characteristics specified in the same technical tables" and using the standard power units manufactured by Dana.

The curves thus show the performances of the power unit in relation to the pump installed. One table describes the main characteristics of the pumps specifying their size (group)

## Motor typology

The two main types of DC motors used by Dana are:

- With permanent magnets, generally low power motors, reversible, in which the magnetic field is generated by permanent magnets and excitation is constant;
- With wound fields: generally medium power, unidirectional, where both excitation and armature windings are electrically driven. These are then divided into two other families: series connection and compound.

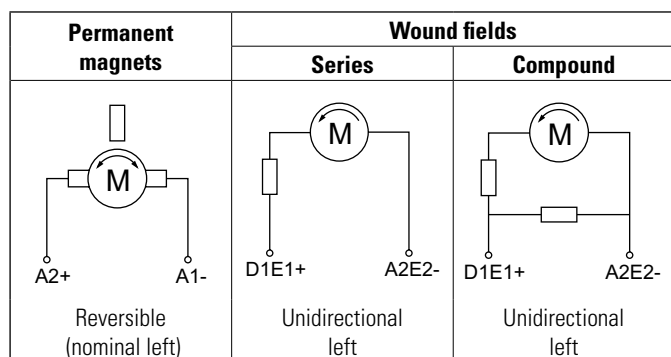

## Duty cycle

In order to ensure the correct choice of the motor, must be known the type of duty cycle required by the application and it has to be compared with the motor features.

Duty types S1, S2, S3 are defined according to standards EN 60034-1, corresponding to CEI 2-3.

## Definitions

### Duty type

A continuous, short time or periodic duty, comprising one or more loads remaining constant for the duration specified, or a non-periodic duty in which generally load and speed vary within the permissible operating range.

### Thermal equilibrium

The state reached when the temperature rises of the several parts of the machine do not vary by more than 2°C over a period of 1 h.

### Cyclic duration factor

The ratio between the period of loading, including starting and electric braking, and the duration of the duty cycle, expressed as a percentage.

### Continuous running duty – Duty type S1

Operation at constant load of sufficient duration for thermal equilibrium to be reached.

### Short time duty – Duty type S2

Operation at constant load during a given time, less than that required to reach thermal equilibrium, followed by a rest and de-energized period of sufficient duration to re-establish initial conditions

### Intermittent periodic duty – Duty type S3

A sequence of identical duty cycles, each including a period of operation at constant load and a rest and de-energized period. The duration of a cycle is generally 10 min. The value S3 is expressed as a percentage. For example S3=25% means that the load on the motor can be constant for 25% of cycle time (2.5 minutes); then you need a rest position for the remaining 75 % of cycle time (7.5 minutes) before starting over a new cycle.

## Protection degree

The degree of protection is indicated in accordance with standard EN 60034-5 corresponding to CEI 2-16. The codes to indicate degree of protection are made by the letters IP followed by two characteristics numerals.

The protection degree are valid in many cases only for motors assembled on power units or other products manufactured by Dana.

## Insulation class

The insulation class indicated is in accordance with standard EN corresponding to CEI 15-26. It indicates the maximum appropriate temperature for the product in nominal operating conditions, without damages to the insulating material of the motor.

Insulation class	Y	A	E	B	F	H
Temperature (°C)	90	105	120	130	155	180

## How to choose the motor

Each motor has its own characteristic curve. The main specifications are: flow rate (in l/min or US gpm), pressure (in bar or psi), current (in Ampere) and duty type S2 (in minutes) or S3 (in percentage of working time).

### Reference data

- Maximum nominal pressure  $P_{max} = 290$  Bar (4206 psi)
- Oil ISO VG32 at temperature 35°C (viscosity 40 cSt)
- Outside temperature 25°C
- Maximum nominal current  $I_{max} = 300A$
- Constant stabilized voltage detected at the terminals of the electric motor.

As a function of pressure and pump displacement, determines the flow rate, drawing a vertical line from the pressure value, intercepting the curve relating the pump, in fact you can read the flow rate on the ordinate. For example: pressure 100 bar (1450 psi), pump 3.8 cm<sup>3</sup>/rev (0.23 in<sup>3</sup>/rev), you have a flow rate of 10 l/min (2.6 US gpm).

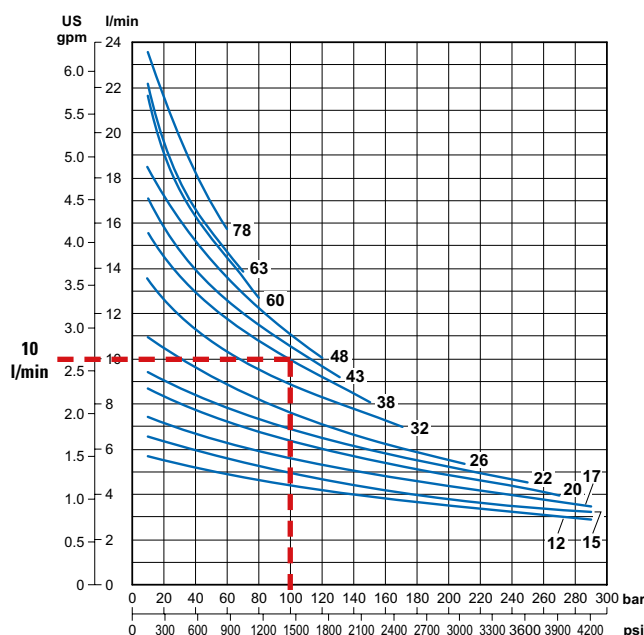

# Introduction



Similarly you can read the value of current absorption in the related diagram. With the same data of the previous example you have a current consumption of 217 A.

## Example of installation

The following is an example of electrical connection

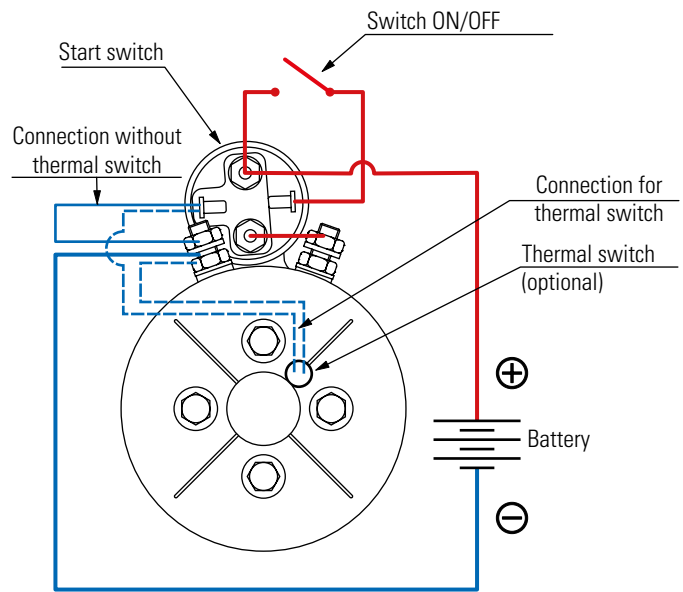
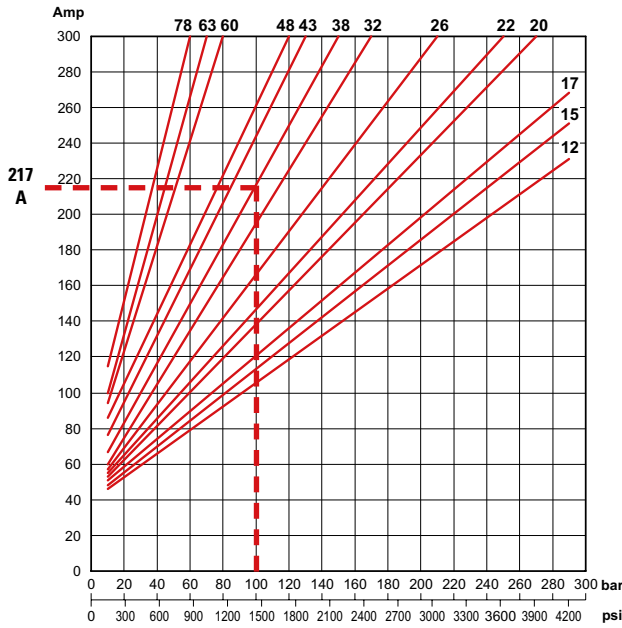

Taking again the current consumption on the S2-S3 diagram, you have a S2 duty equal to 1.55 (1'32") minutes and a S3 duty equal to 5.1 % (30 s on a cycle of 10 minutes).

All electrical connections and disconnections must be performed by trained, specialized personnel.

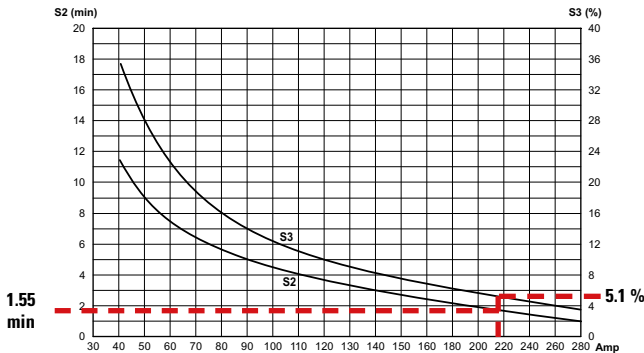

When wiring a motor, it is important to consider the cross-sectional area and length of the power cables. Cables with overly small cross-sections and overly long lengths may cause voltage drops that could prevent the PU from operating properly.

Use these tightening torque values on the motor terminals and the start switch.

ISO M8	5 ÷ 7 Nm [3.69 ÷ 5.16 lbf · ft]
ISO M6	3 ÷ 5 Nm [2.21 ÷ 3.69 lbf · ft]
5/16-18 UNC-2A	5 ÷ 7 Nm [3.69 ÷ 5.16 lbf · ft]

## Unit of measure conversion

Quantity	Unit	Symbol	Other units	Symbol	Equivalence	Reverse Equivalence
Flow rate	Liters at minutes	l/min	US Gallon /minutes	US gal/min	1 US gal/min=3.7848 l/min	1 l/min = 0. 2642 US gal/min
			UK Gallon /minutes	Imp gal/min	1 Imp gal/min=4.5456 l/min	1 l/min = 0.2199 Imp gal/min
			Cubic feet /minutes	cu ft/min	1 cu ft/min= 28.32 l/min	1 l/min = 0.0353 cu ft/min
Pressure	bar	bar	Pascal	Pa	1 Pa= 10 <sup>-5</sup> bar	1 bar= 10 <sup>5</sup> Pa
			Atmosphere	Atm	1 atm = 1.0132 bar	1 bar= 0.9869 atm
			Kilogram force on cm <sup>2</sup>	kgf /cm <sup>2</sup>	1 kgf /cm <sup>2</sup> = 0.9806 bar	1 bar= 1.0197 kgf/cm <sup>2</sup>
			Pound force on in <sup>2</sup>	lbf/in <sup>2</sup> or psi	1 psi = 0.068948 bar	1 bar= 14.5038 psi

## Main formulae

Flow rate from pump

$$Q[l/min] = V[cm^3/rev] \cdot n[rpm] \cdot \eta_{vol} \cdot 10^{-3}$$

$V$  = displacement (cm<sup>3</sup>/rev)

Torque absorbed by pump

$$T[Nm] = \frac{V[cm^3/rev] \cdot \Delta P [bar]}{20\pi \cdot \eta_{mecc}}$$

$Q$  = flow rate (l/min)

$T$  = torque (Nm)

$N$  = power (kW)

$n$  = speed (rpm)

$\Delta P$  = pressure difference between inlet and outlet (bar)

Power absorbed by pump

$$N[kW] = \frac{2\pi \cdot 10^{-3} \cdot T[Nm] \cdot n[rpm]}{60} = \frac{Q[l/min] \cdot \Delta P [bar]}{600 \cdot \eta_{tot}}$$

$\eta_{mecc}$  = mechanical efficiency

$\eta_{vol}$  = volumetric efficiency

$\eta_{tot}$  = total efficiency

Total efficiency

$$\eta_{tot} = \eta_{mecc} \cdot \eta_{vol}$$

## 12 VDC - 0.35 KW - D.80 MOTOR

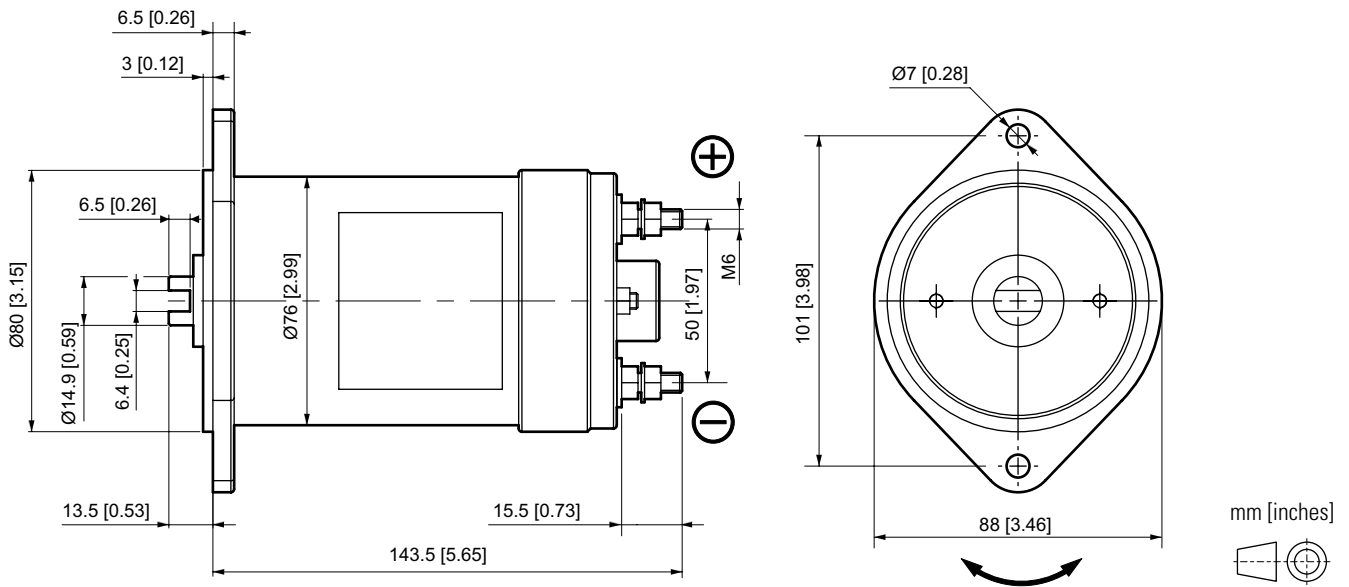

### RATED FEATURES

Voltage	12 VDC
Power	0.35 kW
Nominal diameter	80 mm [3.15 in]
Motor type	Permanent magnet
Rotation	CCW-CW
Protection class IP (with motor assembled on hydraulic power pack)	54
S2 / S3 duty service	see curves
Insulation class	F
Weight	2.2 kg [4.85 lb]

### PUMP TYPE

Code	cc/rev.	GR (Size)
02	0.25	05
04	0.45	05
05	0.56	05
07	0.75	05/1
09	0.9	05/1
12	1.2	05/1

**Performance with GR05 / GR1 pumps**  
**Displacement 0.2 ÷ 1.2 cc/rev [0.012 ÷ 0.073 in<sup>3</sup>/rev]**

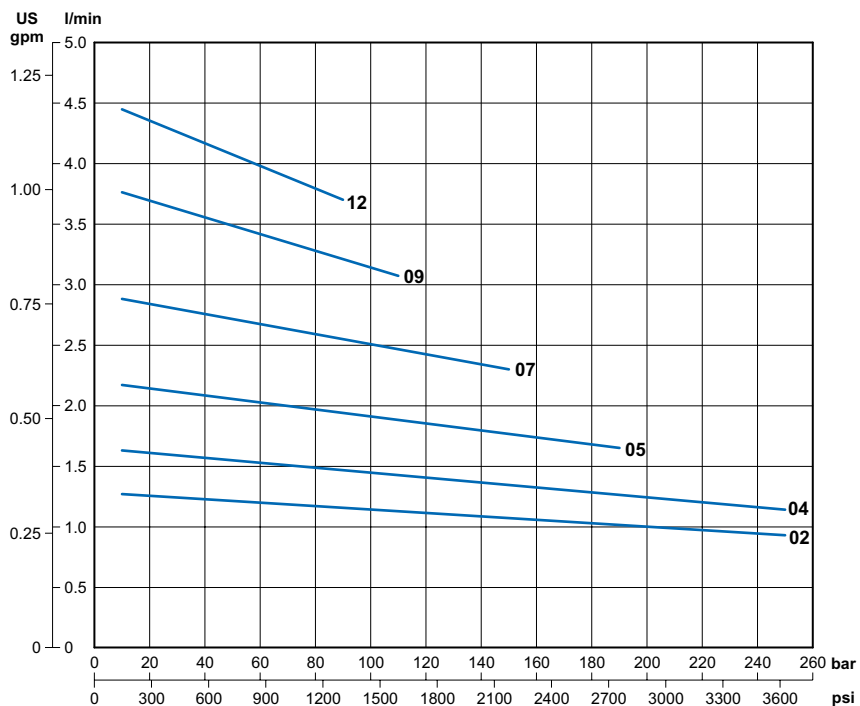

**Current with GR05 / GR1 pumps**  
**Displacement 0.2 ÷ 1.2 cc/rev [0.012 ÷ 0.073 in<sup>3</sup>/rev]**

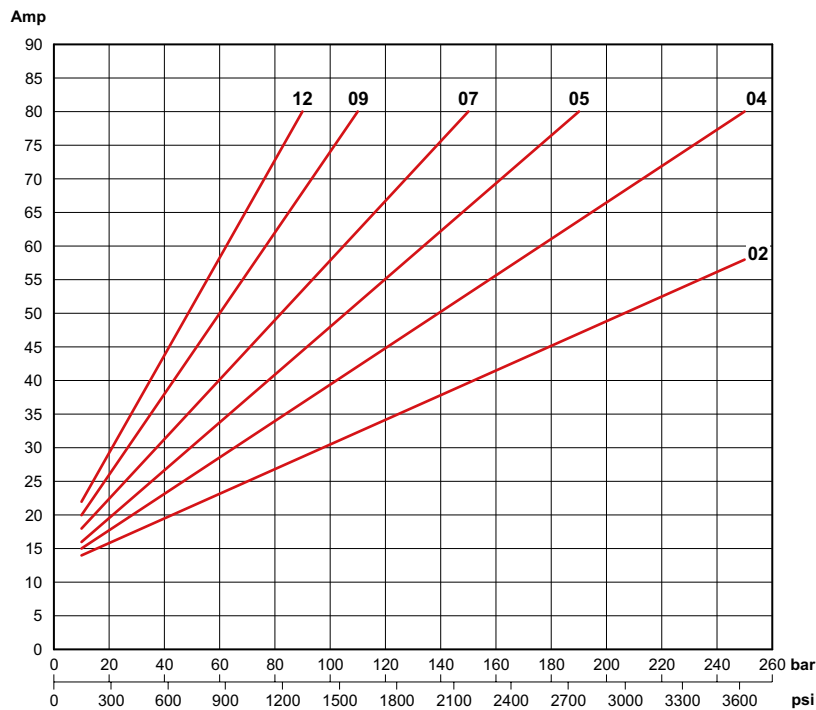

**Thermal characteristics S2 - S3**

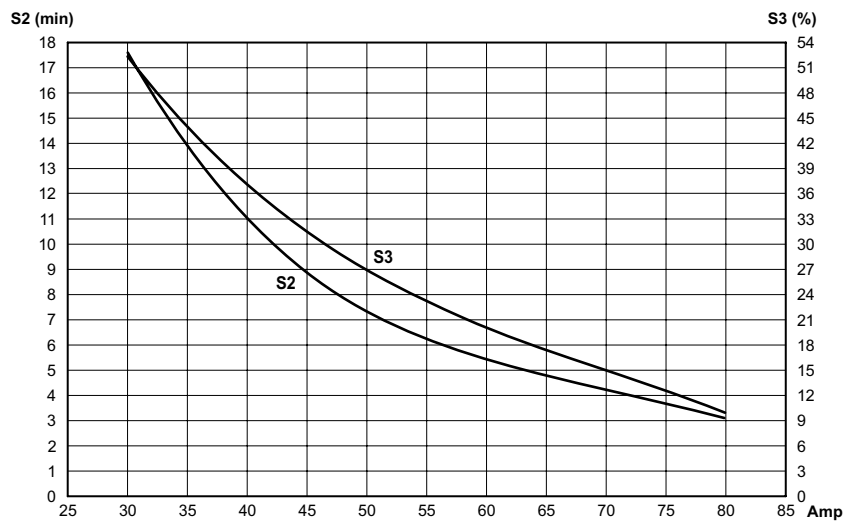

**ORDERING CODE**

Code	Description
<b>25021400</b>	12VDC motor - 0.35 kW

Code	Description
<b>KIT07012.027</b>	Starting switch kit 12VDC - 120A (fixing with clamp)

Reference data: maximum nominal pressure Pmax = 250 bar. Oil ISO VG32 temperature 35°C (viscosity 40 cSt), outside temperature 25°C.

Maximum nominal current I<sub>max</sub> = 80A. Stabilized voltage to 12 Vdc detected at the terminals of the electric motor.

## 24 VDC - 0.4 KW - D.80 MOTOR

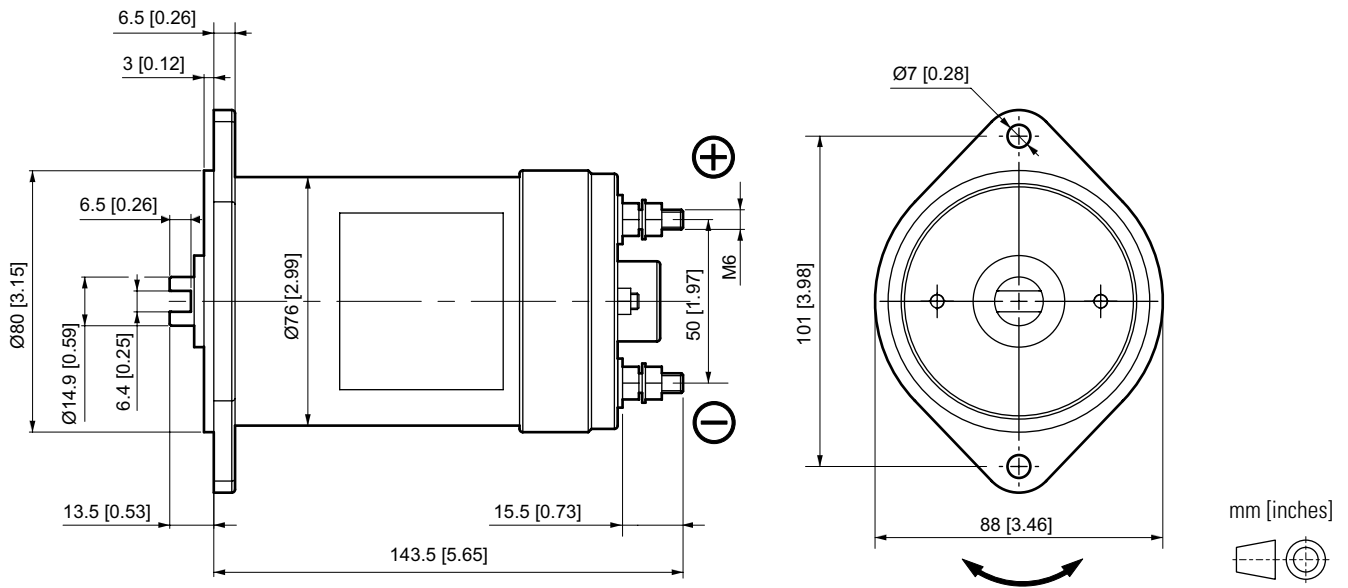

### RATED FEATURES

Voltage	24 VDC
Power	0.4 kW
Nominal diameter	80 mm [3.15 in]
Motor type	Permanent magnet
Rotation	CCW-CW
Protection class IP (with motor assembled on hydraulic power pack)	54
S2 / S3 duty service	see curves
Insulation class	F
Weight	2.2 kg [4.85 lb]

### PUMP TYPE

Code	cc/rev.	GR (Size)
02	0.25	05
04	0.45	05
05	0.56	05
07	0.75	05/1
09	0.9	05/1
12	1.2	05/1

**Performance with GR05 / GR1 pumps**  
**Displacement 0.2 ÷ 1.2 cc/rev [0.012 ÷ 0.073 in<sup>3</sup>/rev]**

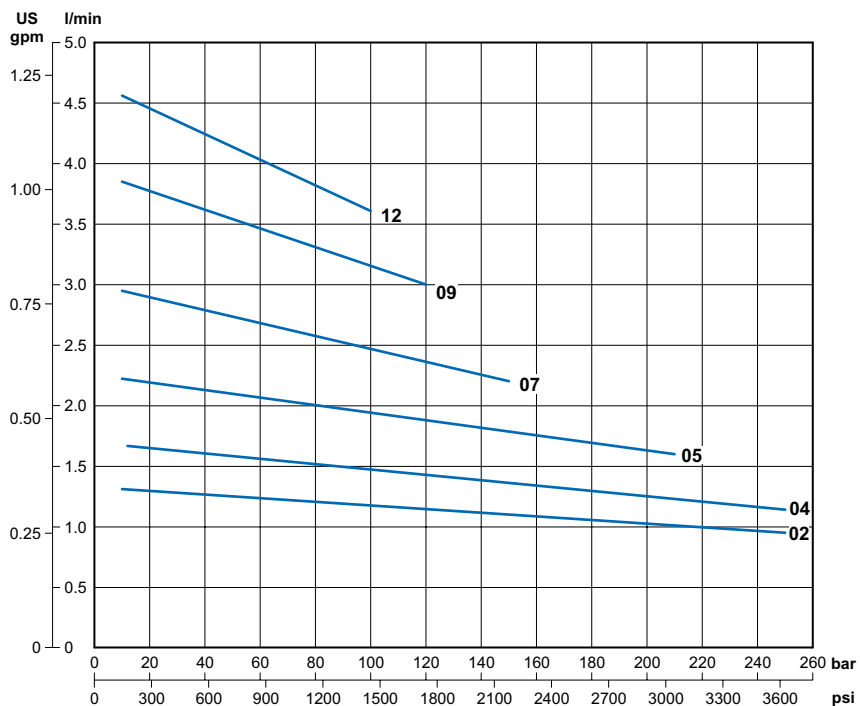

**Current with GR05 / GR1 pumps**  
**Displacement 0.2 ÷ 1.2 cc/rev [0.012 ÷ 0.073 in<sup>3</sup>/rev]**

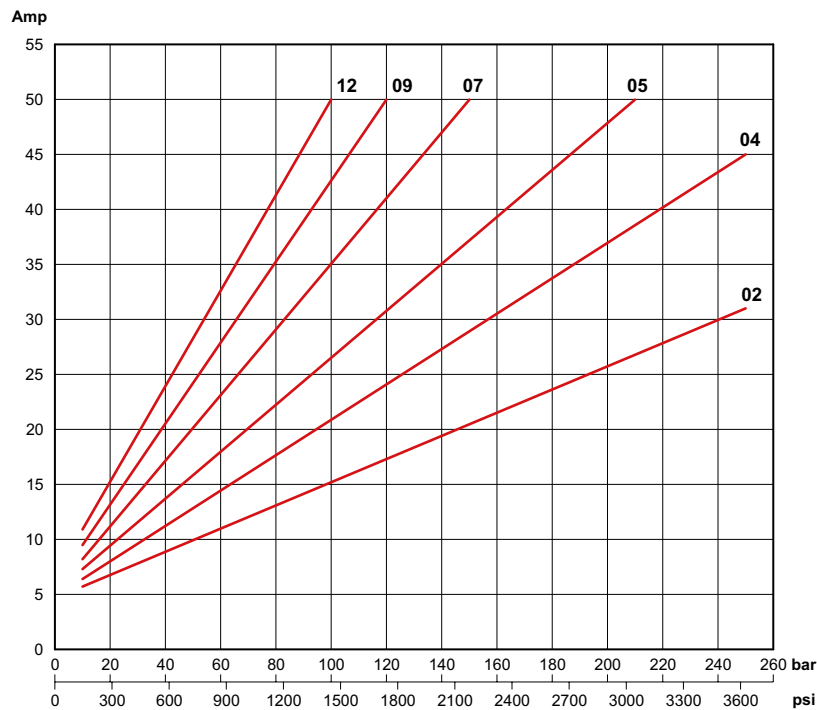

**Thermal characteristics S2 - S3**

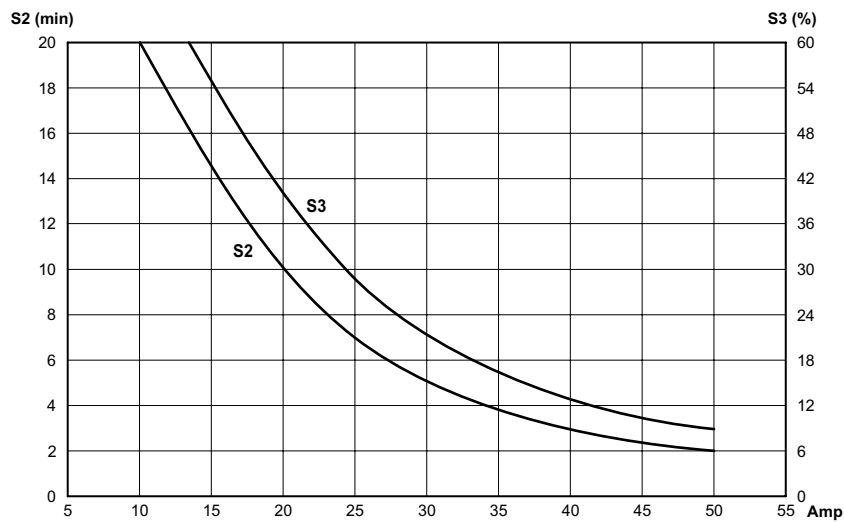

**ORDERING CODE**

Code	Description
<b>25021500</b>	24VDC motor - 0.4 kW

Code	Description
<b>KIT07012.032</b>	Starting switch kit 24VDC - 120A (fixing with clamp)

Reference data: maximum nominal pressure Pmax = 250 bar. Oil ISO VG32 temperature 35°C (viscosity 40 cSt), outside temperature 25°C.

Maximum nominal current I<sub>max</sub> = 50A. Stabilized voltage to 24 Vdc detected at the terminals of the electric motor.

## 12 VDC - 0.5 KW - D.80 MOTOR

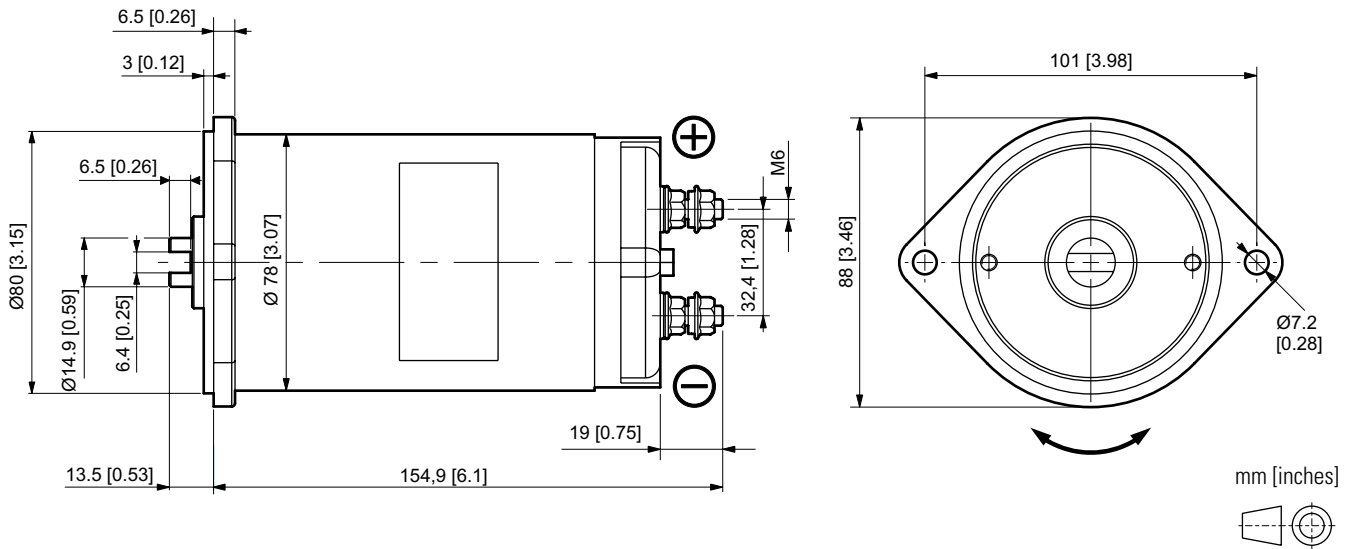

### RATED FEATURES

Voltage	12 VDC
Power	0.5 kW
Nominal diameter	80 mm [3.15 in]
Motor type	Permanent magnet
Rotation	CCW-CW
Protection class IP (with motor assembled on hydraulic power pack)	54
S2 / S3 duty service	see curves
Insulation class	F
Weight	2.5 kg [5.51 lb]

### PUMP TYPE

Code	cc/rev.	GR (Size)
02	0.25	05
04	0.45	05
05	0.56	05
07	0.75	05/1
09	0.9	05/1
12	1.2	05/1

**Performance with GR05 / GR1 pumps**  
**Displacement 0.2 ÷ 1.2 cc/rev [0.012 ÷ 0.073 in<sup>3</sup>/rev]**

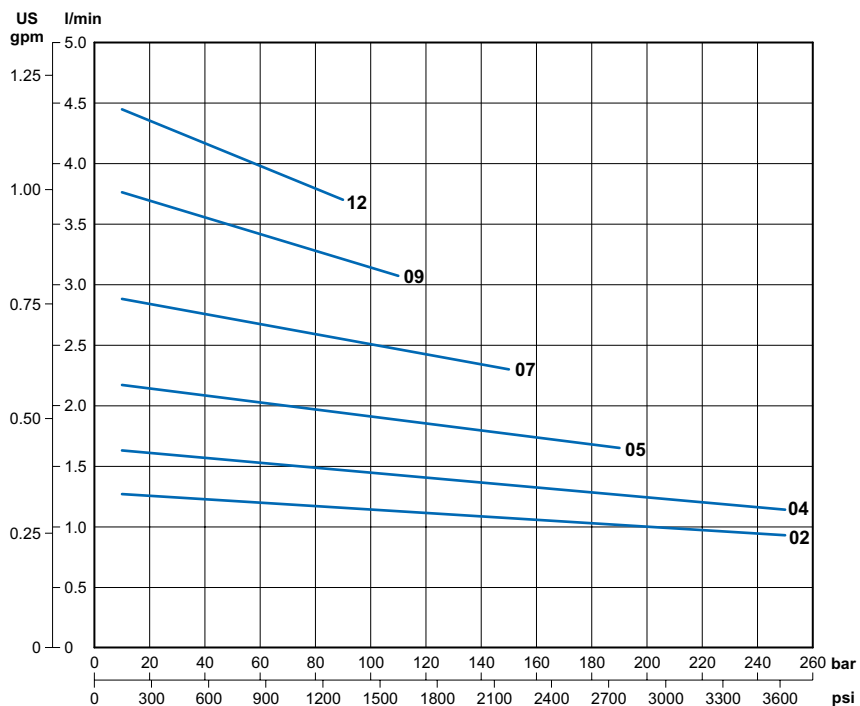

**Current with GR05 / GR1 pumps**  
**Displacement 0.2 ÷ 1.2 cc/rev [0.012 ÷ 0.073 in<sup>3</sup>/rev]**

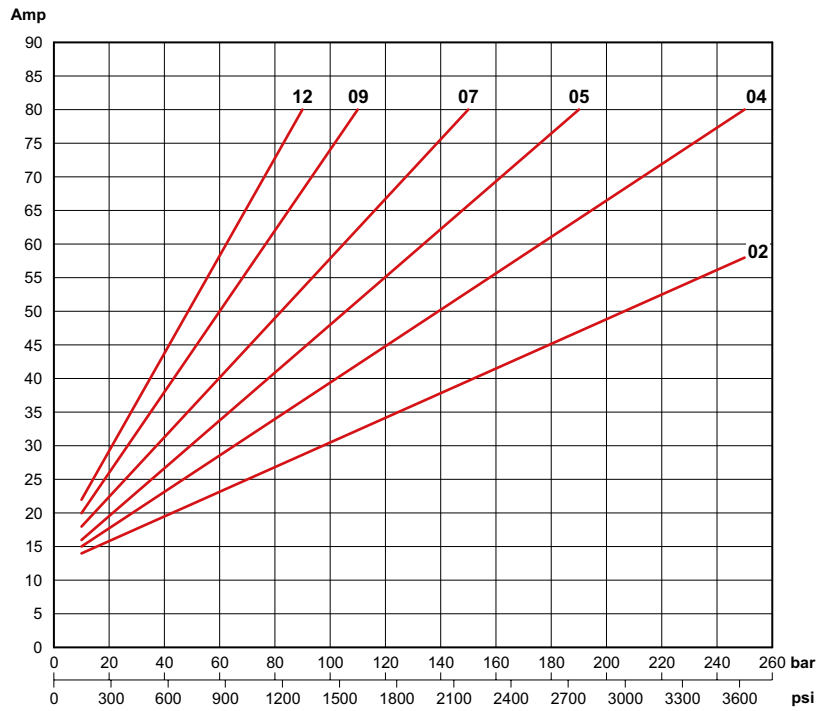

**Thermal characteristics S2 - S3**

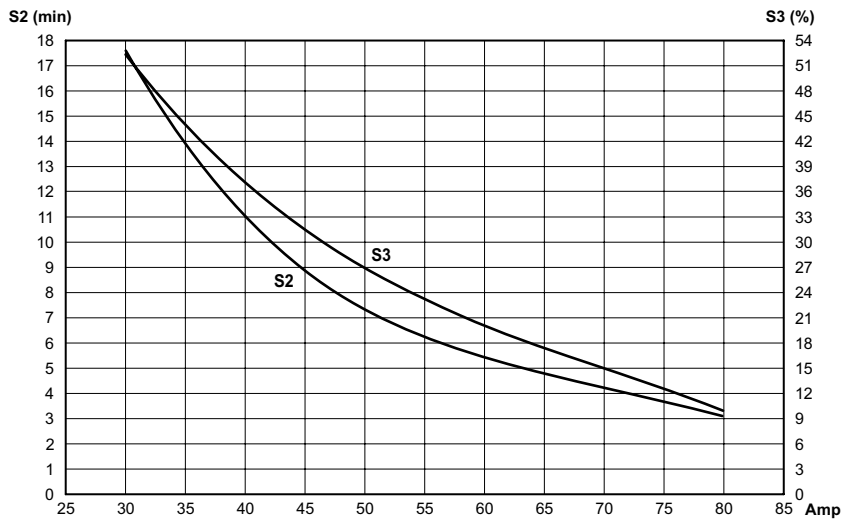

**ORDERING CODE**

Code	Description
<b>25024200</b>	12VDC motor - 0.35 kW

Code	Description
<b>KIT07012.027</b>	Starting switch kit 12VDC - 120A (fixing with clamp)

Reference data: maximum nominal pressure Pmax = 250 bar. Oil ISO VG32 temperature 35°C (viscosity 40 cSt), outside temperature 25°C.

Maximum nominal current I<sub>max</sub> = 80A. Stabilized voltage to 12 Vdc detected at the terminals of the electric motor.



**Current with GR05 / GR1 pumps**  
**Displacement 0.2 ÷ 1.2 cc/rev [0.012 ÷ 0.073 in<sup>3</sup>/rev]**

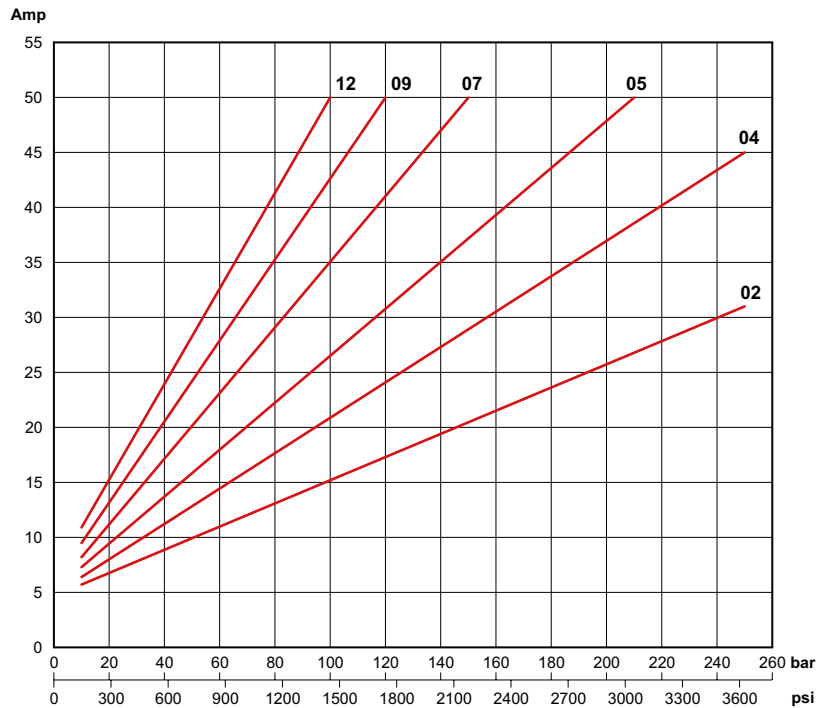

**Thermal characteristics S2 - S3**

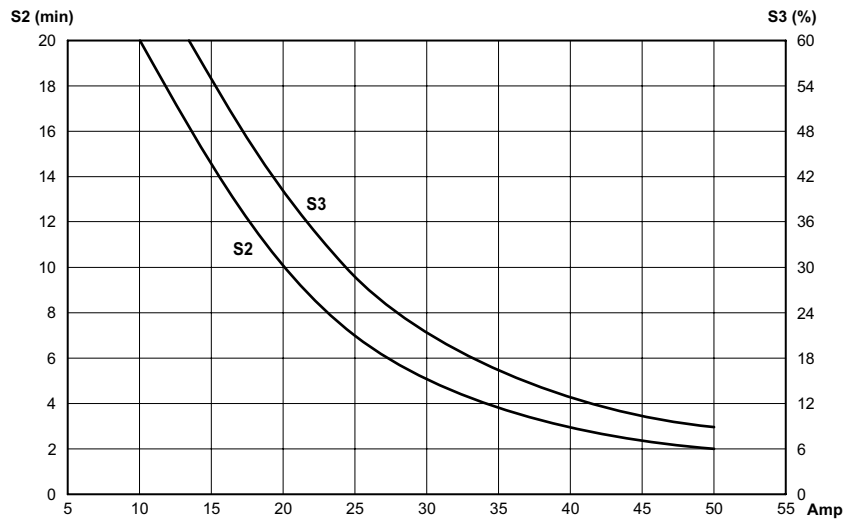

**ORDERING CODE**

Code	Description
<b>25024300</b>	24VDC motor - 0.5 kW

Code	Description
<b>KIT07012.032</b>	Starting switch kit 24VDC - 120A (fixing with clamp)

Reference data: maximum nominal pressure Pmax = 250 bar. Oil ISO VG32 temperature 35°C (viscosity 40 cSt), outside temperature 25°C.

Maximum nominal current I<sub>max</sub> = 50A. Stabilized voltage to 24 Vdc detected at the terminals of the electric motor.

## 12 VDC - 0.7 KW - D.80 MOTOR

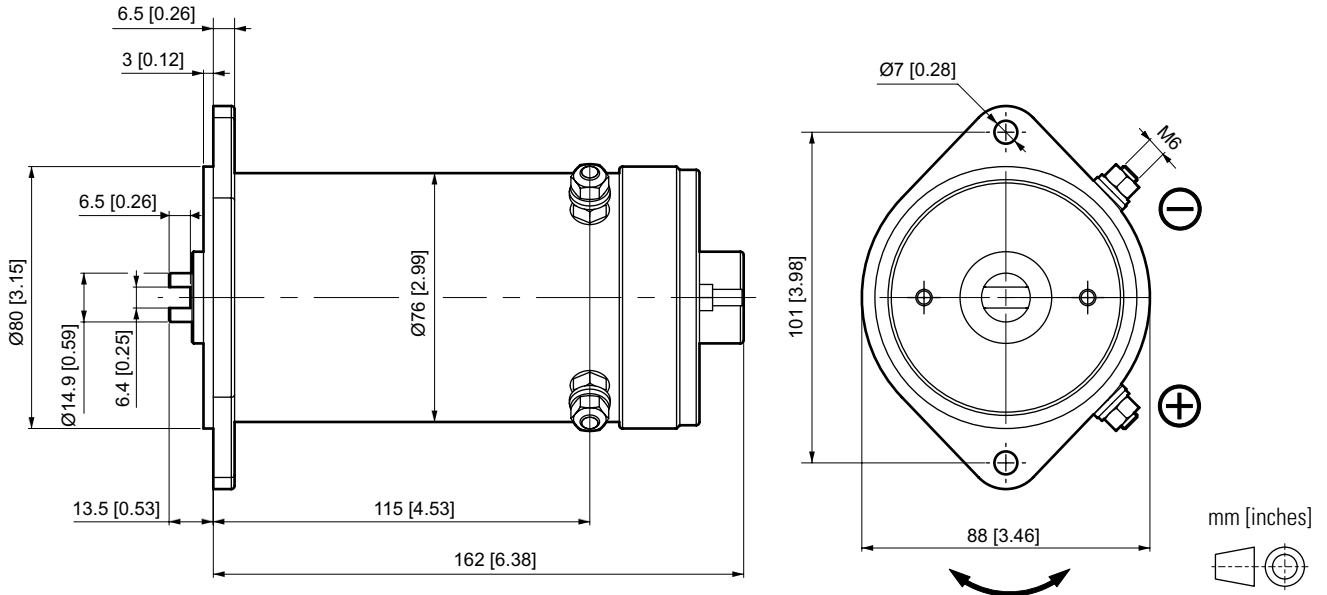

### RATED FEATURES

Voltage	12 VDC
Power	0.7 kW
Nominal diameter	80 mm [3.15 in]
Motor type	Permanent magnet
Rotation	CCW-CW
Protection class IP (with motor assembled on hydraulic power pack)	54
S2 / S3 duty service	see curves
Insulation class	F
Weight	2.7 kg [5.95 lb]

### PUMP TYPE

Code	cc/rev.	GR (Size)
02	0.25	05
04	0.45	05
05	0.56	05
07	0.75	05/1
09	0.9	05/1
12	1.2	05/1

Performance with GR05 / GR1 pumps  
Displacement 0.2 ÷ 1.2 cc/rev [0.012 ÷ 0.073 in<sup>3</sup>/rev]

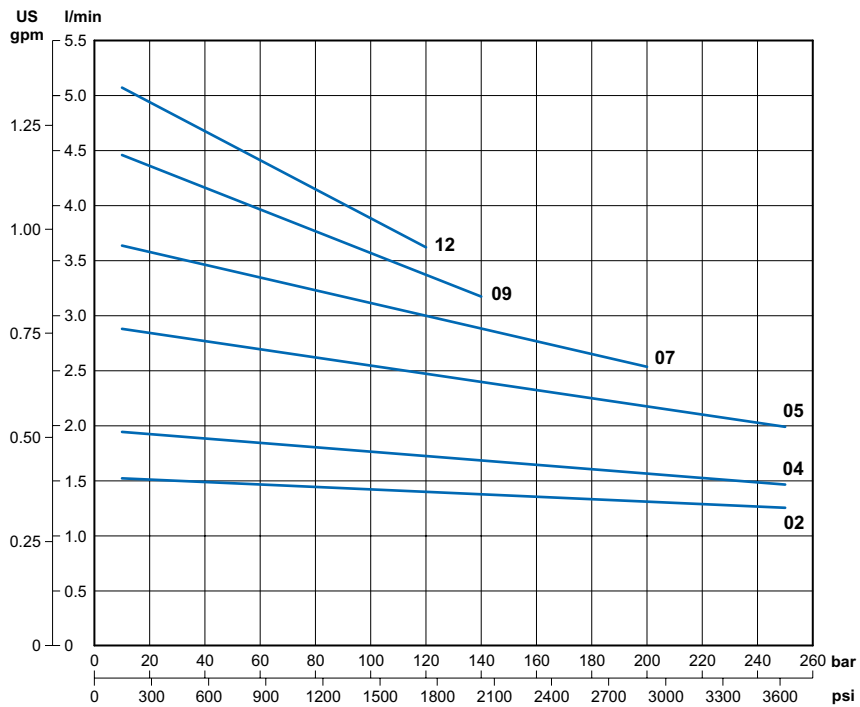

**Current with GR05 / GR1 pumps**  
**Displacement 0.2 ÷ 1.2 cc/rev [0.012 ÷ 0.073 in<sup>3</sup>/rev]**

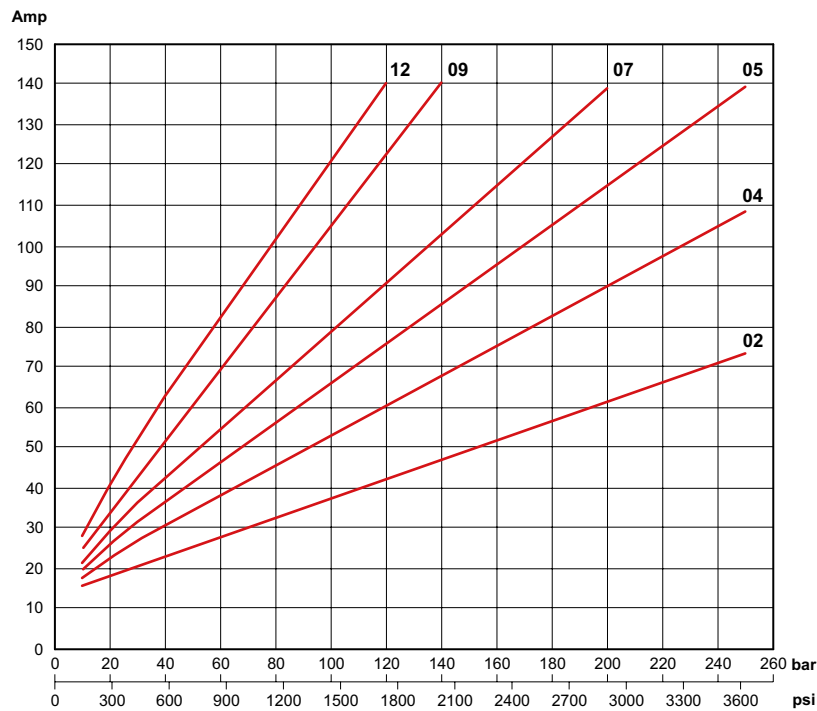

**Thermal characteristics S2 - S3**

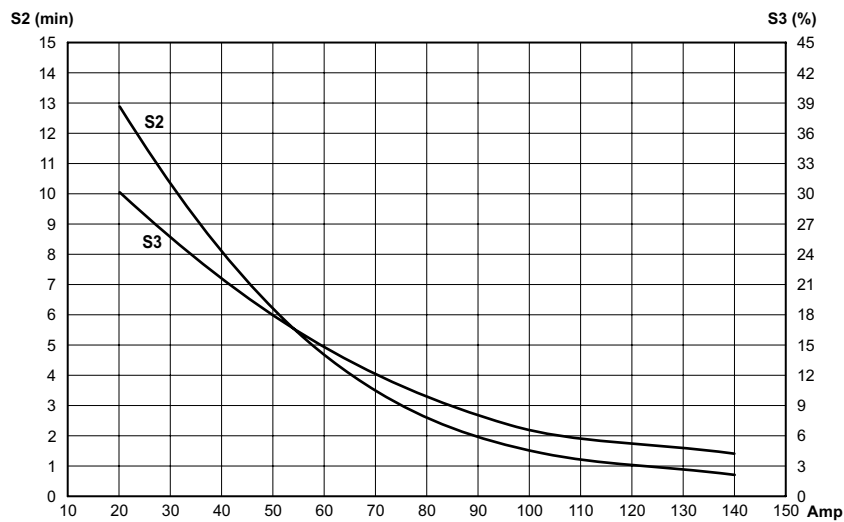

**ORDERING CODE**

Code	Description
<b>25021600</b>	12VDC motor - 0.7 kW

Code	Description
<b>KIT07012.027</b>	Starting switch kit 12VDC - 120A (fixing with clamp)

Reference data: maximum nominal pressure Pmax = 250 bar. Oil ISO VG32 temperature 35°C (viscosity 40 cSt), outside temperature 25°C.

Maximum nominal current I<sub>max</sub> = 140A. Stabilized voltage to 12 Vdc detected at the terminals of the electric motor.

## 24 VDC - 0.8 KW - D.80 MOTOR

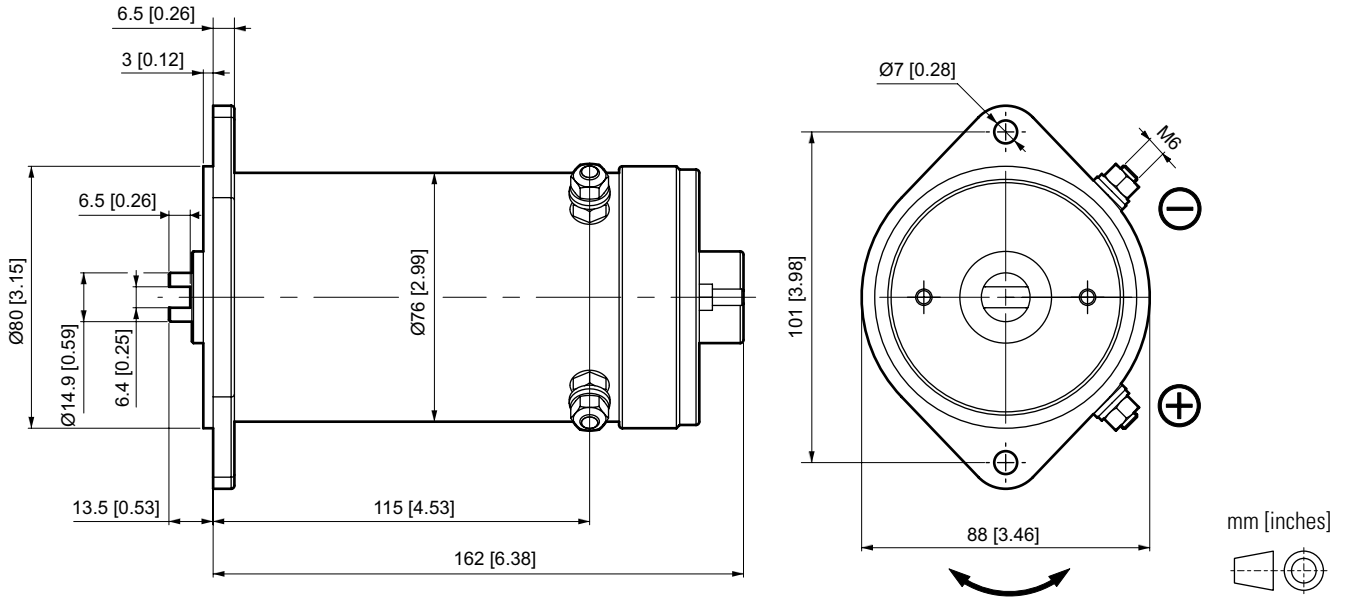

### RATED FEATURES

Voltage	24 VDC
Power	0.8 kW
Nominal diameter	80 mm [3.15 in]
Motor type	Permanent magnet
Rotation	CCW-CW
Protection class IP (with motor assembled on hydraulic power pack)	54
S2 / S3 duty service	see curves
Insulation class	F
Weight	2.7 kg [5.95 lb]

### PUMP TYPE

Code	cc/rev.	GR (Size)
02	0.25	05
04	0.45	05
05	0.56	05
07	0.75	05/1
09	0.9	05/1
12	1.2	05/1

**Performance with GR05 / GR1 pumps**  
**Displacement 0.2 ÷ 1.2 cc/rev [0.012 ÷ 0.073 in<sup>3</sup>/rev]**

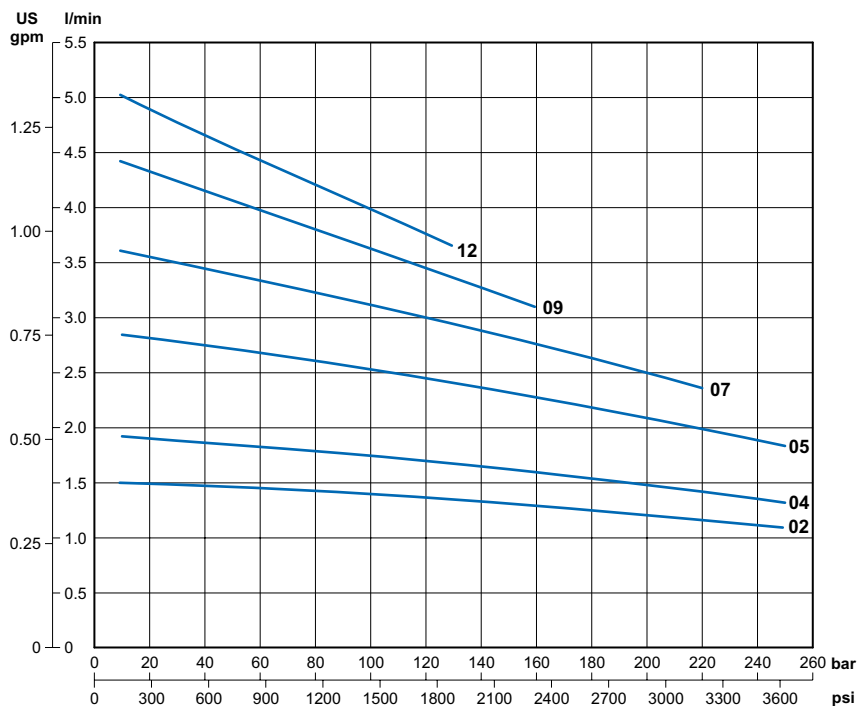

**Current with GR05 / GR1 pumps**  
**Displacement 0.2 ÷ 1.2 cc/rev [0.012 ÷ 0.073 in<sup>3</sup>/rev]**

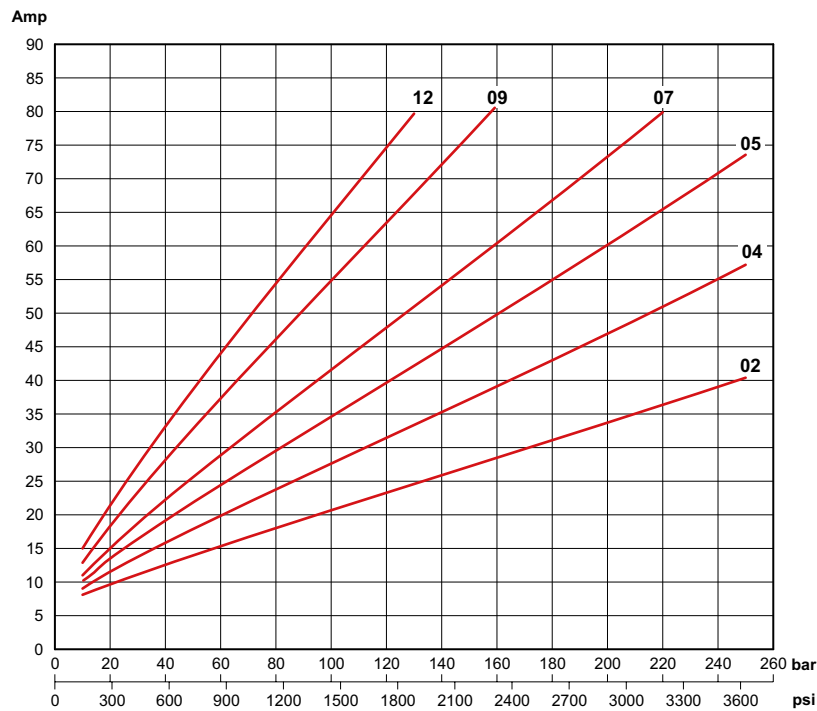

**Thermal characteristics S2 - S3**

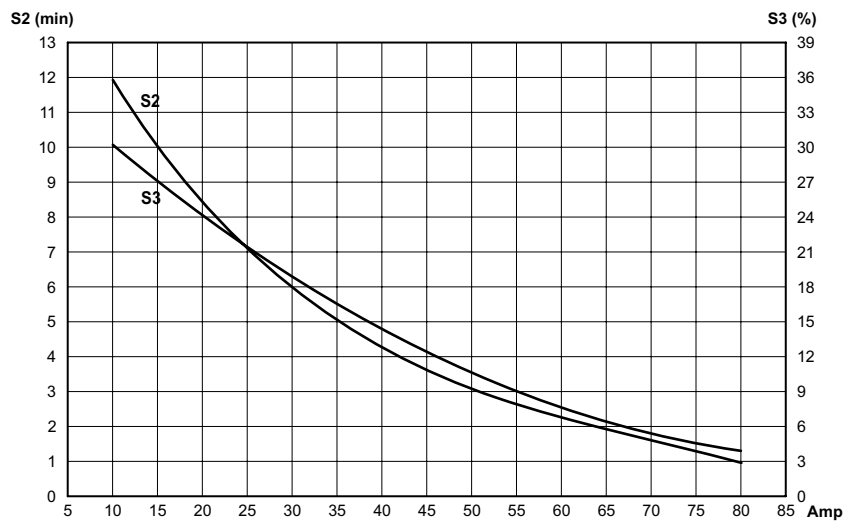

**ORDERING CODE**

Code	Description
<b>25021700</b>	24VDC motor - 0.8 kW

Code	Description
<b>KIT07012.032</b>	Starting switch kit 24VDC - 120A (fixing with clamp)

Reference data: maximum nominal pressure Pmax = 250 bar. Oil ISO VG32 temperature 35°C (viscosity 40 cSt), outside temperature 25°C.

Maximum nominal current I<sub>max</sub> = 80A. Stabilized voltage to 24 Vdc detected at the terminals of the electric motor.

## 12 VDC - 1.6 KW - D.115 MOTOR

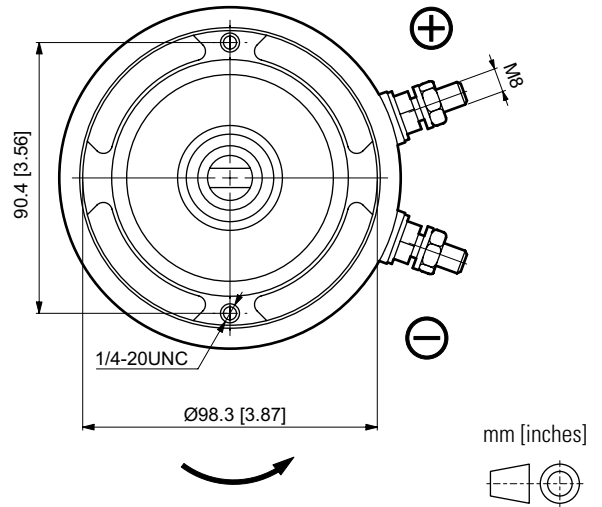
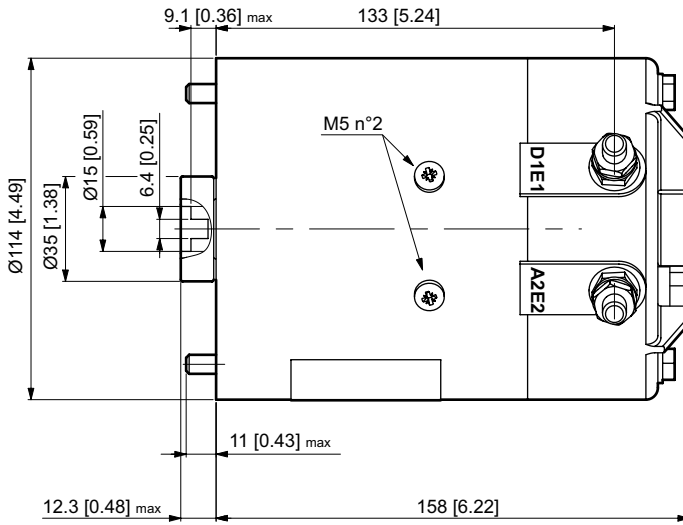

### RATED FEATURES

Voltage	12 VDC
Power	1.6 kW
Nominal diameter	115 mm [4.53 in]
Motor type	Wound field compound
Rotation	CCW
Protection class IP (with motor assembled on hydraulic power pack)	54
S2 / S3 duty service	see curves
Insulation class	F
Weight	6.7 kg [14.77 lb]

### PUMP TYPE

Code	cc/rev.	GR (Size)
02	0.25	05
04	0.45	05
05	0.56	05
07	0.75	05/1
09	0.9	05/1
10	1.0	05/1
12	1.2	05/1
15	1.5	1
17	1.7	1
20	2.0	1

Code	cc/rev.	GR (Size)
22	2.2	1
26	2.6	1
32	3.2	1
38	3.8	1
43	4.3	1
48	4.8	1
60	6.0	1
63	6.3	1
78	7.8	1

Performance with GR05 / GR1 pumps  
Displacement 0.2 ÷ 1.0 cc/rev [0.012 ÷ 0.061 in<sup>3</sup>/rev]

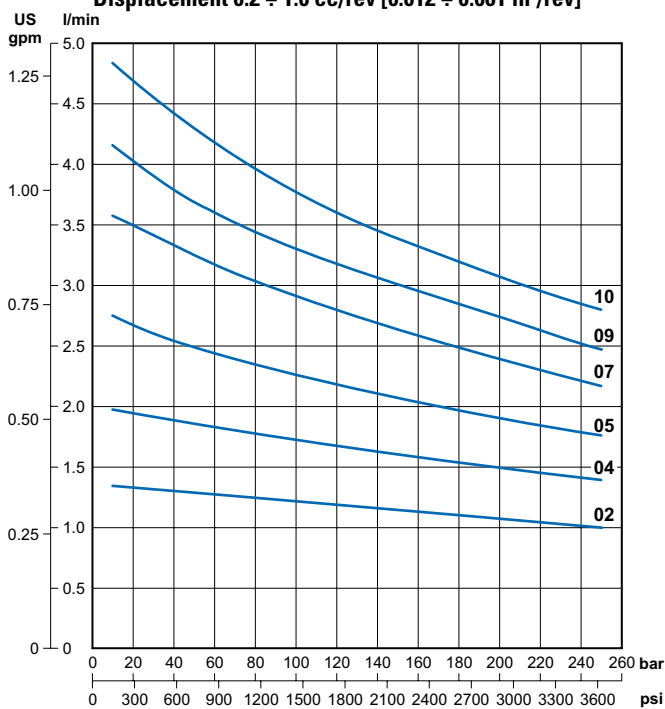

Performance with GR05 / GR1 pumps  
Displacement 1.2 ÷ 7.8 cc/rev [0.073 ÷ 0.476 in<sup>3</sup>/rev]

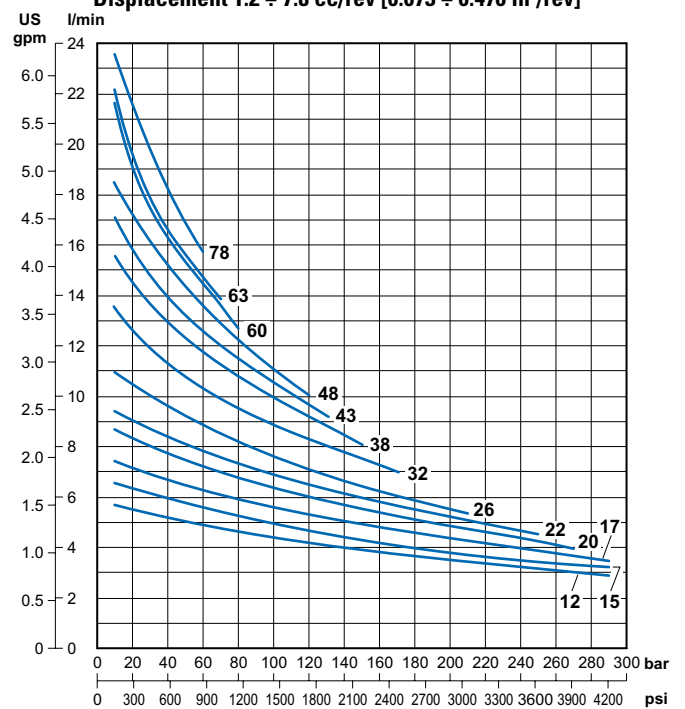

**Current with GR05 / GR1 pumps**  
Displacement 0.2 ÷ 1.0 cc/rev [0.012 ÷ 0.061 in<sup>3</sup>/rev]

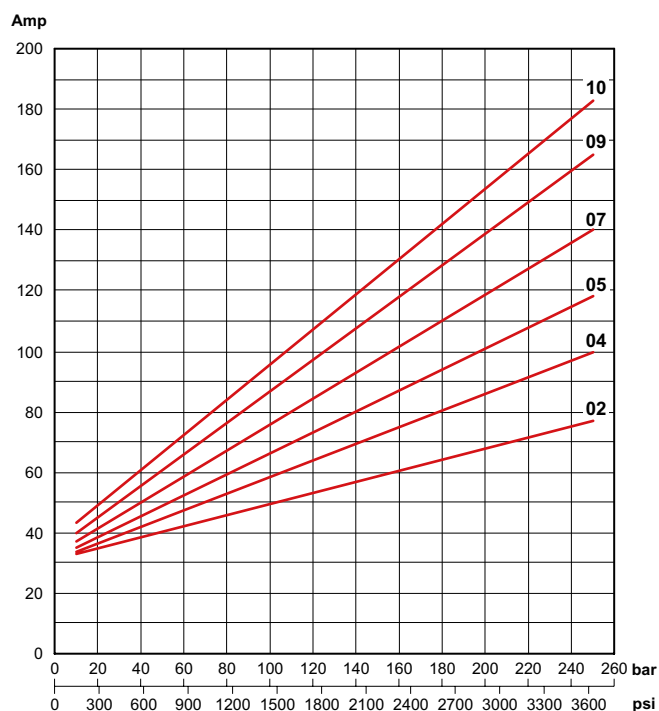

**Current with GR05 / GR1 pumps**  
Displacement 1.2 ÷ 7.8 cc/rev [0.073 ÷ 0.476 in<sup>3</sup>/rev]

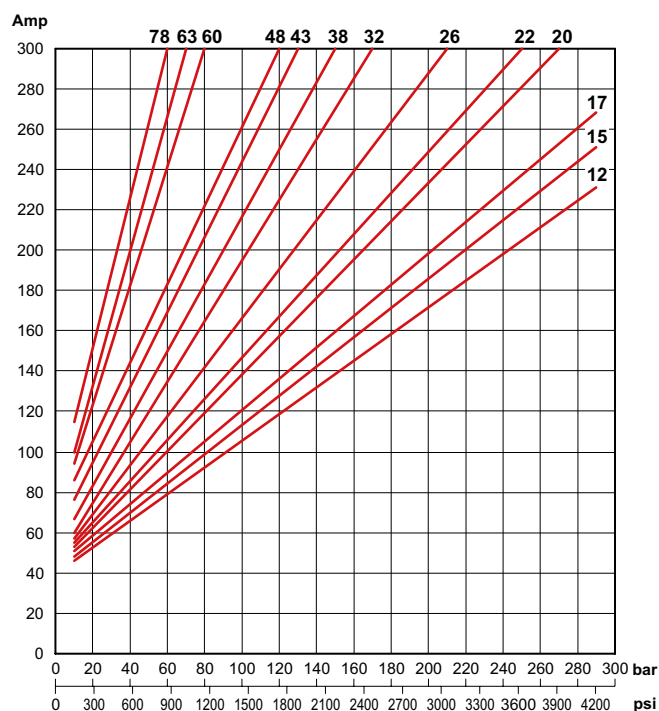

### Thermal characteristics S2 - S3

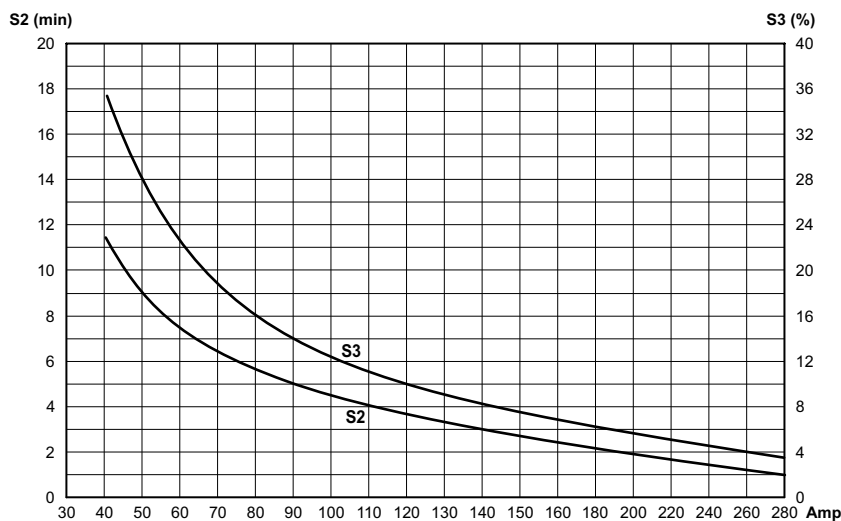

Motor with thermal switch

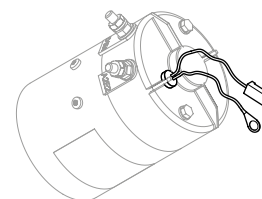

### ORDERING CODE

Code	Description
25021100	12VDC motor - 1.6 kW
25016600	12VDC motor - 1.6 kW with thermal switch
90340009	Thermal switch

Code	Description
KIT07012.025	Starting switch kit 12VDC - 120A (fixing with screws)

Reference data: maximum nominal pressure Pmax = 250 bar. Oil ISO VG32 temperature 35°C (viscosity 40 cSt), outside temperature 25°C.

Maximum nominal current Imax = 140A. Stabilized voltage to 12 Vdc detected at the terminals of the electric motor.

## 24 VDC - 2.2 KW - D.115 MOTOR

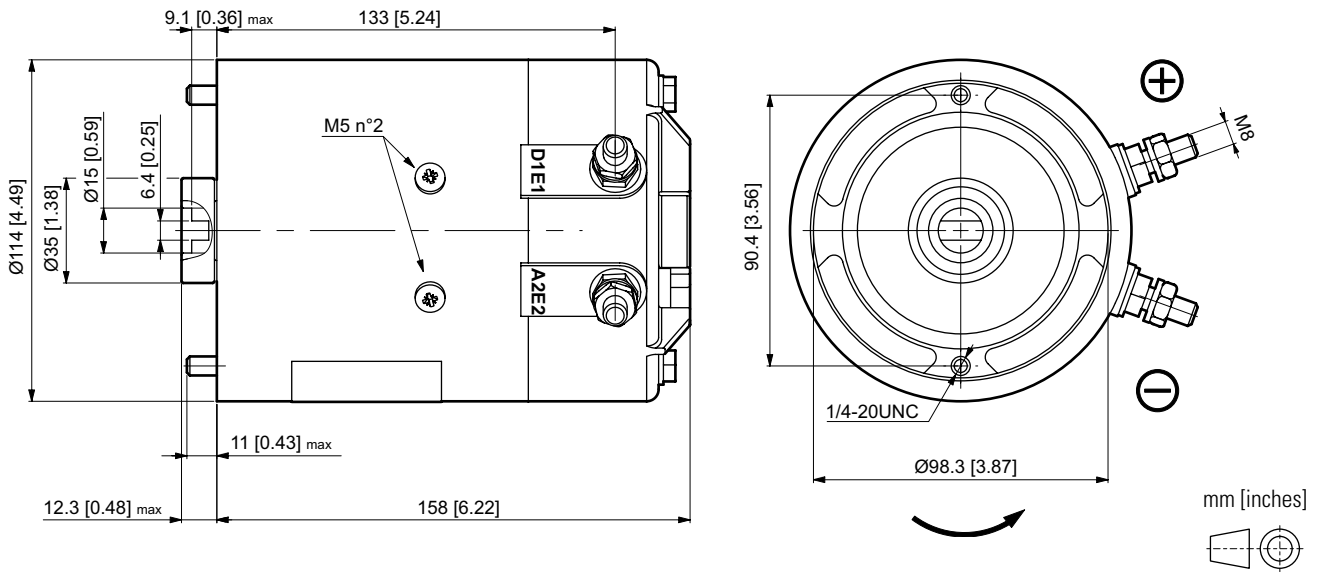

### RATED FEATURES

Voltage	24 VDC
Power	2.2 kW
Nominal diameter	115 mm [4.53 in]
Motor type	Wound field compound
Rotation	CCW
Protection class IP (with motor assembled on hydraulic power pack)	54
S2 / S3 duty service	see curves
Insulation class	F
Weight	6.7 kg [14.77 lb]

### PUMP TYPE

Code	cc/rev.	GR (Size)
02	0.25	05
04	0.45	05
05	0.56	05
07	0.75	05/1
09	0.9	05/1
10	1.0	05/1
12	1.2	05/1
15	1.5	1
17	1.7	1
20	2.0	1

Code	cc/rev.	GR (Size)
22	2.2	1
26	2.6	1
32	3.2	1
38	3.8	1
43	4.3	1
48	4.8	1
60	6.0	1
63	6.3	1
78	7.8	1

Performance with GR05 / GR1 pumps  
Displacement 0.2 ÷ 1.0 cc/rev [0.012 ÷ 0.061 in<sup>3</sup>/rev]

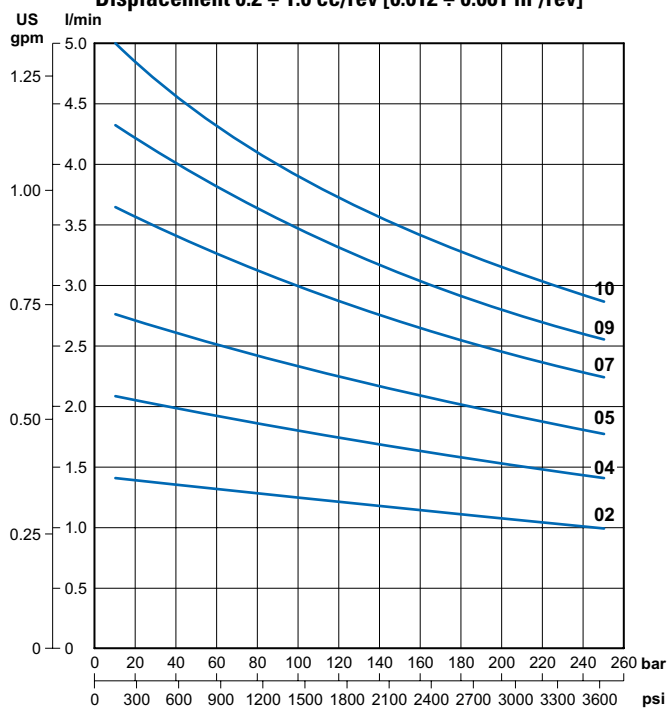

Performance with GR05 / GR1 pumps  
Displacement 1.2 ÷ 7.8 cc/rev [0.073 ÷ 0.476 in<sup>3</sup>/rev]

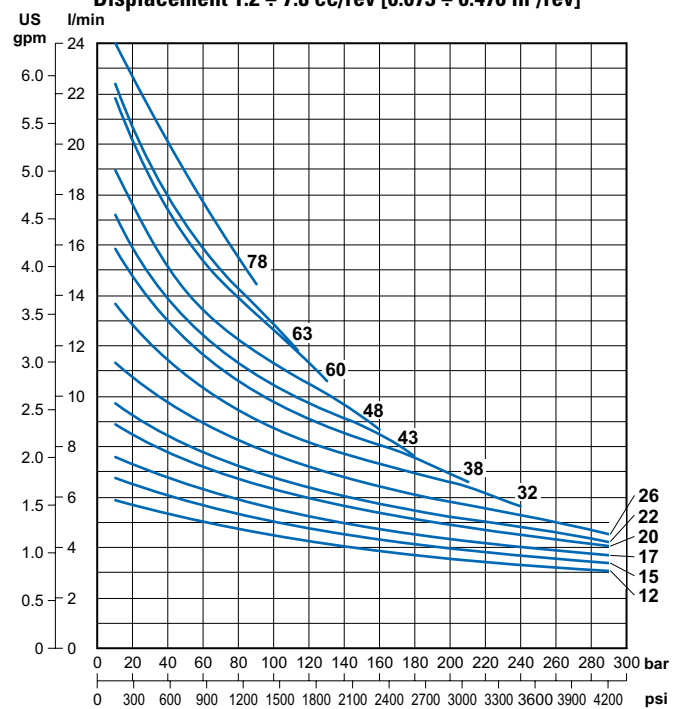

**Current with GR05 / GR1 pumps**  
Displacement 0.2 ÷ 1.0 cc/rev [0.012 ÷ 0.061 in<sup>3</sup>/rev]

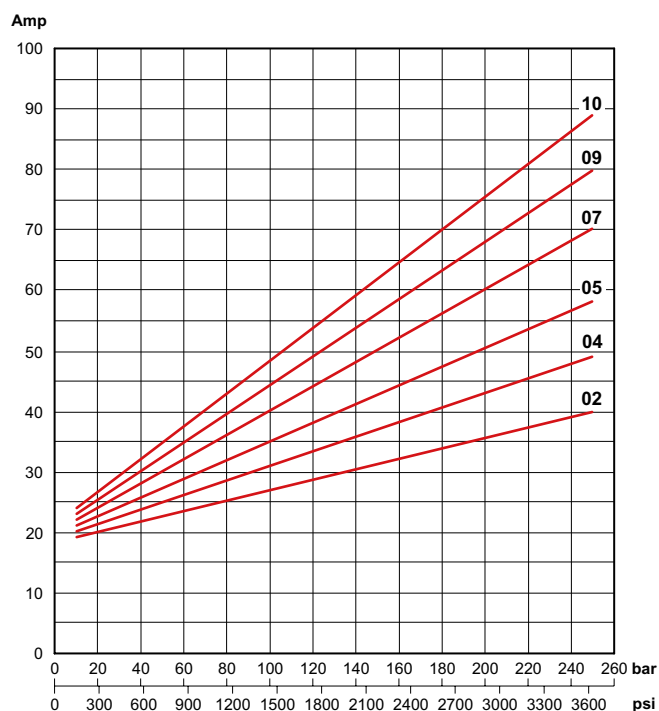

**Current with GR05 / GR1 pumps**  
Displacement 1.2 ÷ 7.8 cc/rev [0.073 ÷ 0.476 in<sup>3</sup>/rev]

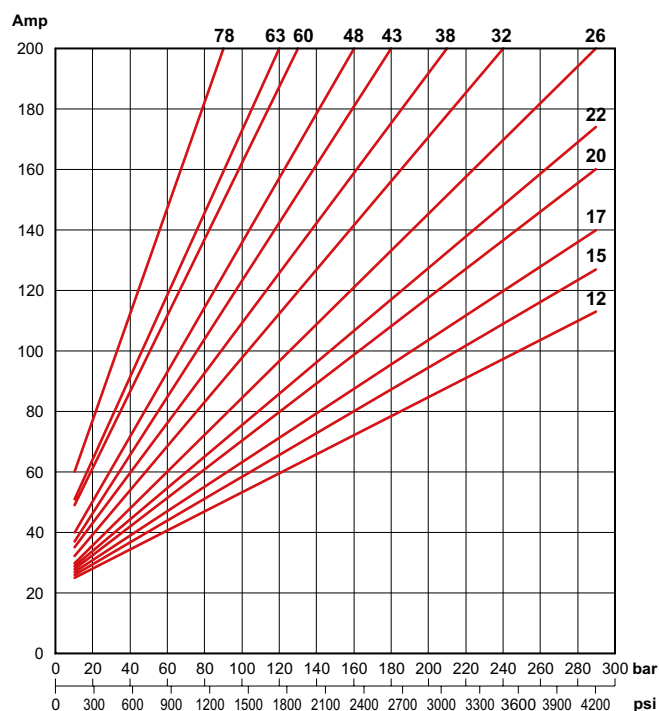

### Thermal characteristics S2 - S3

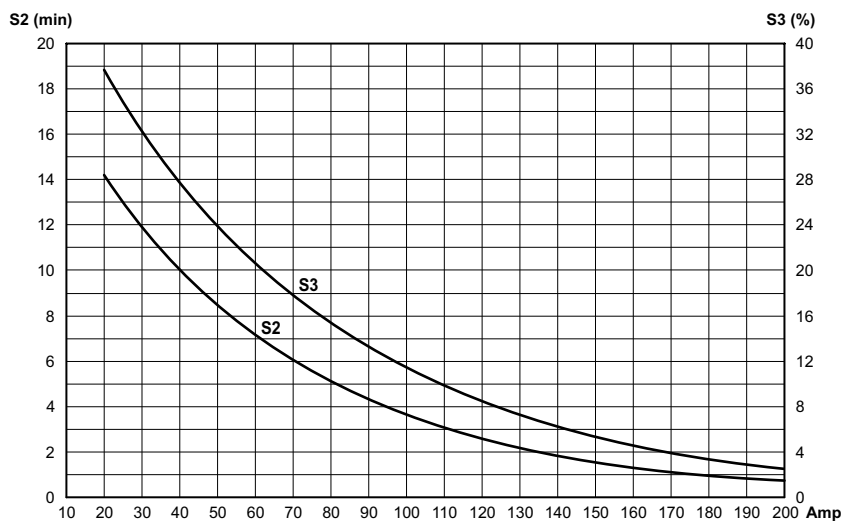

Motor with thermal switch

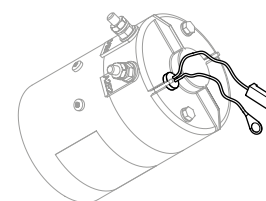

### ORDERING CODE

Code	Description
25021200	24VDC motor - 2.2 kW
25016700	24VDC motor - 2.2 kW with thermal switch
90340009	Thermal switch Ø 16 mm

Code	Description
KIT07012.026	Starting switch kit 24VDC - 120A (fixing with screws)

Reference data: maximum nominal pressure Pmax = 290 bar. Oil ISO VG32 temperature 35°C (viscosity 40 cSt), outside temperature 25°C.

Maximum nominal current Imax = 200A. Stabilized voltage to 24 Vdc detected at the terminals of the electric motor.

## 12 VDC- 1.5 KW - D.115 MOTOR

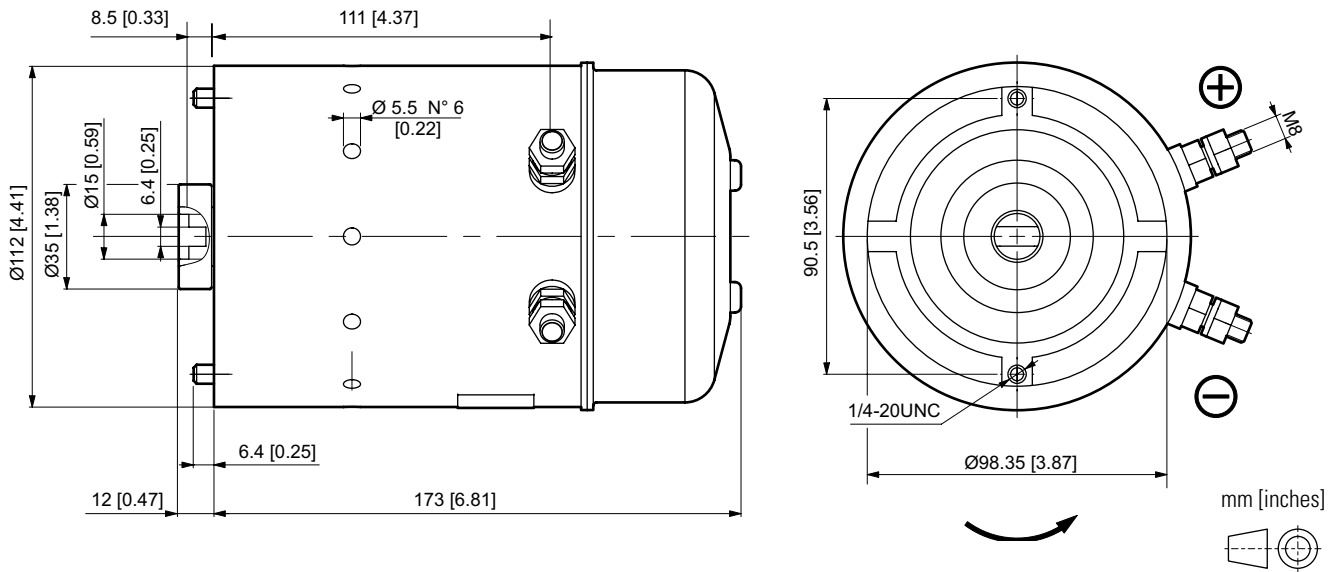

### RATED FEATURES

Voltage	12 VDC
Power	1.5 kW
Nominal diameter	115 mm [4.53 in]
Motor type	Wound field compound
Rotation	CCW
Protection class IP (with motor assembled on hydraulic power pack)	54
S2 / S3 duty service	see curves
Insulation class	F
Weight	6.7 kg [14.77 lb]

### PUMP TYPE

Code	cc/rev.	GR (Size)
<b>02</b>	0.25	05
<b>04</b>	0.45	05
<b>05</b>	0.56	05
<b>07</b>	0.75	05/1
<b>09</b>	0.9	05/1
<b>10</b>	1.0	05/1
<b>12</b>	1.2	05/1
<b>15</b>	1.5	1
<b>17</b>	1.7	1
<b>20</b>	2.0	1

Code	cc/rev.	GR (Size)
<b>22</b>	2.2	1
<b>26</b>	2.6	1
<b>32</b>	3.2	1
<b>38</b>	3.8	1
<b>43</b>	4.3	1
<b>48</b>	4.8	1
<b>60</b>	6.0	1
<b>63</b>	6.3	1
<b>78</b>	7.8	1

Performance with GR05 / GR1 pumps  
Displacement 0.2 ÷ 1.0 cc/rev [0.012 ÷ 0.061 in<sup>3</sup>/rev]

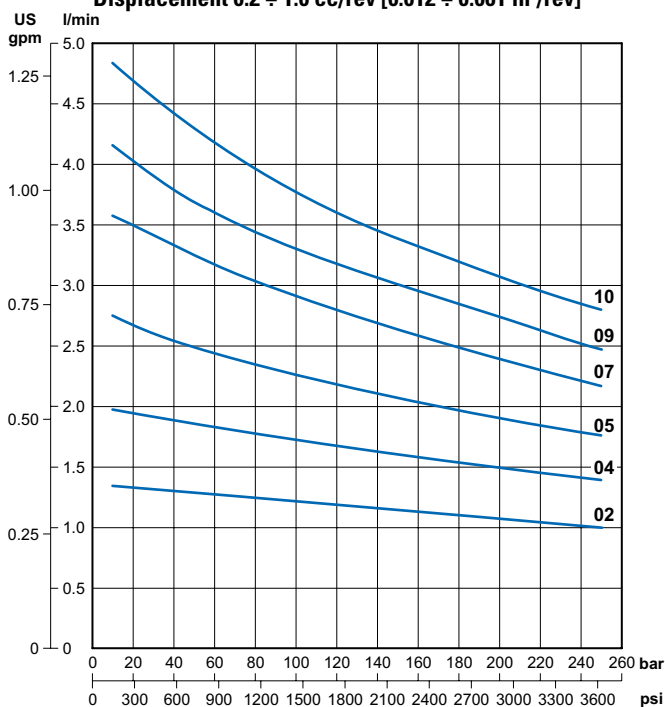

Performance with GR05 / GR1 pumps  
Displacement 1.2 ÷ 7.8 cc/rev [0.073 ÷ 0.476 in<sup>3</sup>/rev]

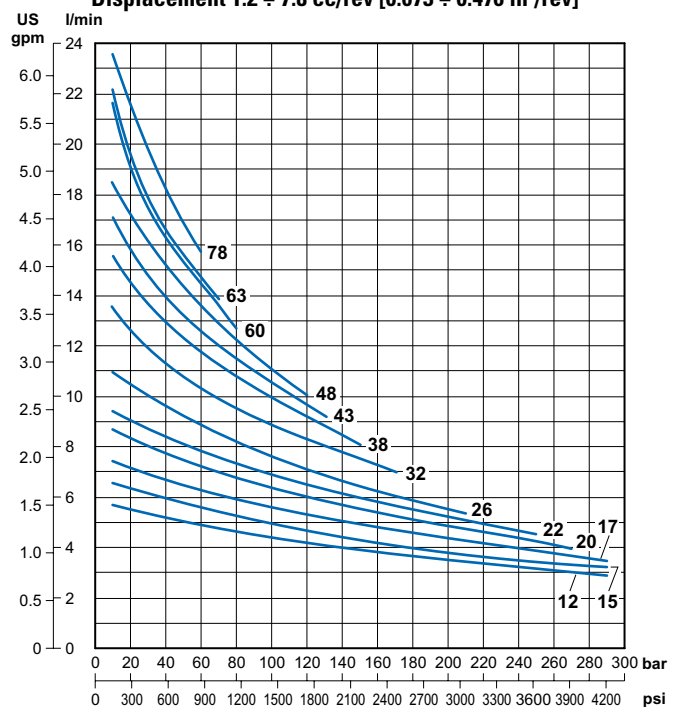

**Current with GR05 / GR1 pumps**  
Displacement 0.2 ÷ 1.0 cc/rev [0.012 ÷ 0.061 in<sup>3</sup>/rev]

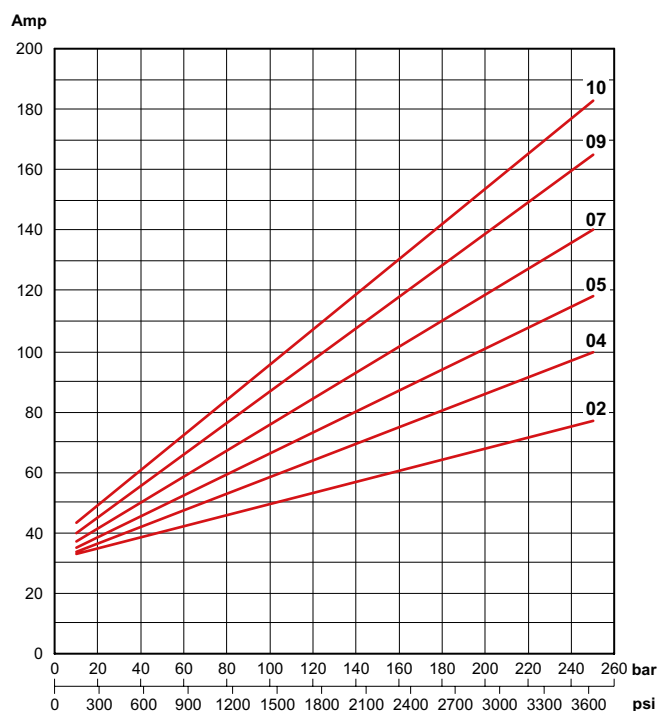

**Current with GR05 / GR1 pumps**  
Displacement 1.2 ÷ 7.8 cc/rev [0.073 ÷ 0.476 in<sup>3</sup>/rev]

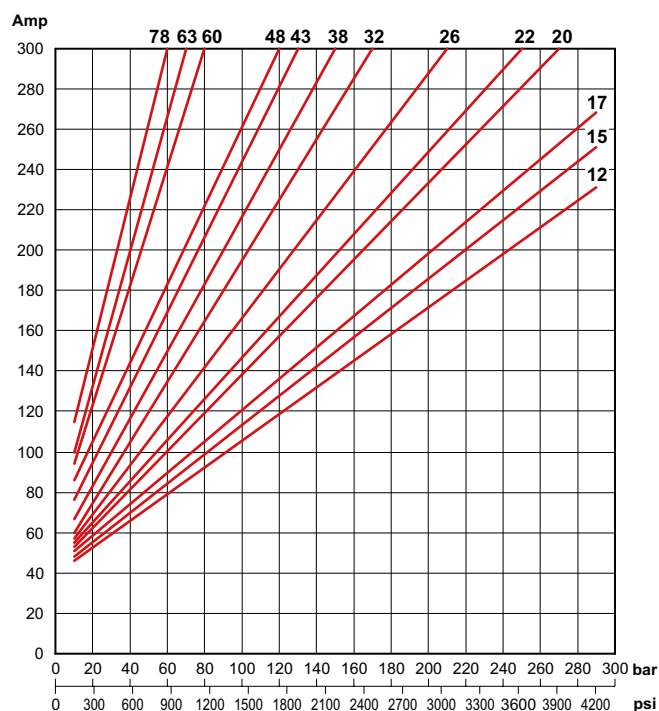

### Thermal characteristics S2 - S3

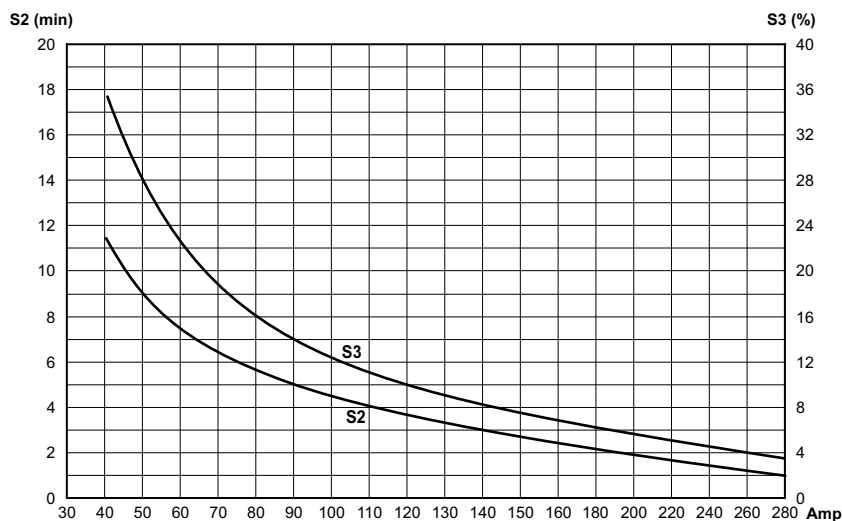

### ORDERING CODE

Code	Description
<b>25022200</b>	12VDC motor - 1.5 kW

Code	Description
<b>KIT07012.033</b>	Starting switch kit 12VDC - 120A (fixing with clamp)

Reference data: maximum nominal pressure Pmax = 290 bar. Oil ISO VG32 temperature 35°C (viscosity 40 cSt), outside temperature 25°C.

Maximum nominal current Imax = 300A. Stabilized voltage to 12 Vdc detected at the terminals of the electric motor.

# 25022200 FAN



## 12 VDC - 1.5 KW - D.115 MOTOR

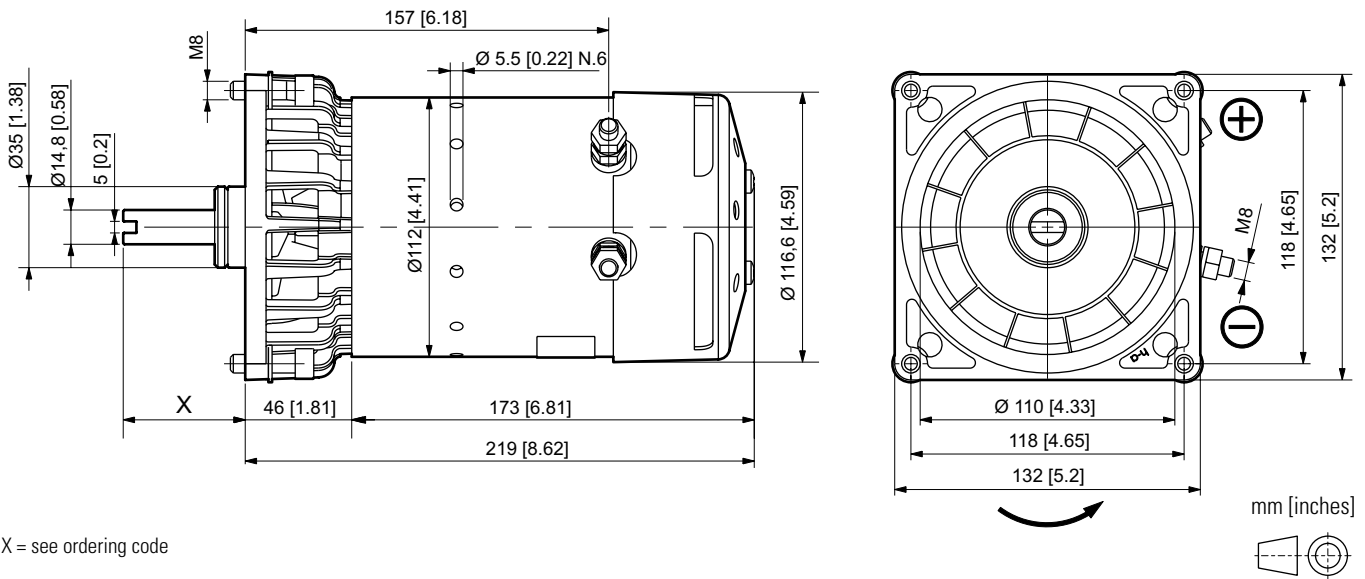

X = see ordering code

### RATED FEATURES

Voltage	12 VDC
Power	1.5 kW
Nominal diameter	115 mm [4.53 in]
Motor type	Wound field compound
Rotation	CCW
Protection class IP (with motor assembled on hydraulic power pack)	10
S2 / S3 duty service	see curves
Insulation class	F
Weight	7.4 kg [16.31 lb]

### PUMP TYPE

Code	cc/rev.	GR (Size)
<b>02</b>	0.25	05
<b>04</b>	0.45	05
<b>05</b>	0.56	05
<b>07</b>	0.75	05/1
<b>09</b>	0.9	05/1
<b>10</b>	1.0	05/1
<b>12</b>	1.2	05/1
<b>15</b>	1.5	1
<b>17</b>	1.7	1
<b>20</b>	2.0	1

Code	cc/rev.	GR (Size)
<b>22</b>	2.2	1
<b>26</b>	2.6	1
<b>32</b>	3.2	1
<b>38</b>	3.8	1
<b>43</b>	4.3	1
<b>48</b>	4.8	1
<b>60</b>	6.0	1
<b>63</b>	6.3	1
<b>78</b>	7.8	1

Performance with GR05 / GR1 pumps  
Displacement 0.2 ÷ 1.0 cc/rev [0.012 ÷ 0.061 in<sup>3</sup>/rev]

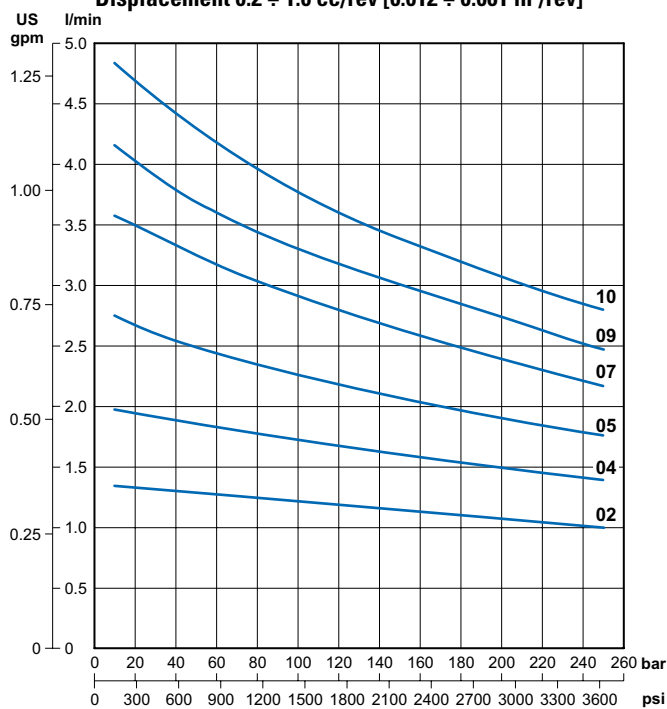

Performance with GR05 / GR1 pumps  
Displacement 1.2 ÷ 7.8 cc/rev [0.073 ÷ 0.476 in<sup>3</sup>/rev]

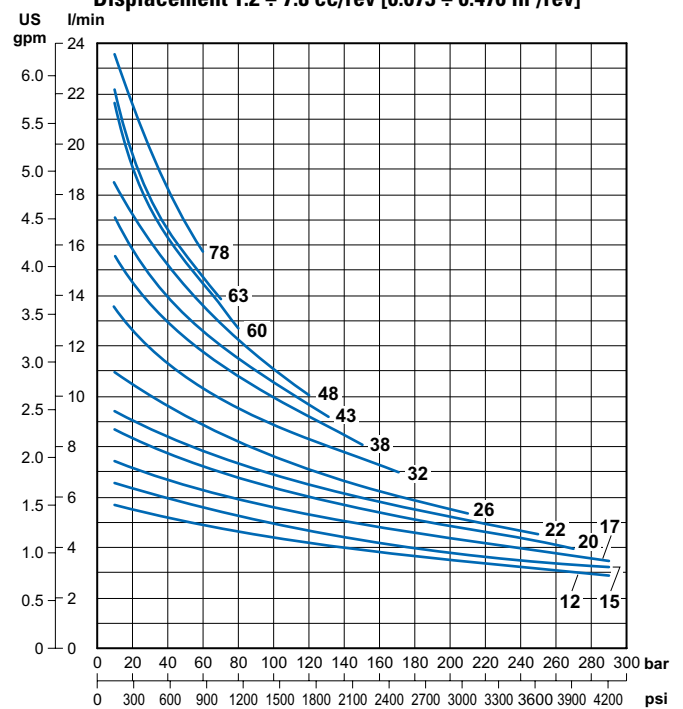

# 25022200 FAN



**Current with GR05 / GR1 pumps**  
Displacement 0.2 ÷ 1.0 cc/rev [0.012 ÷ 0.061 in<sup>3</sup>/rev]

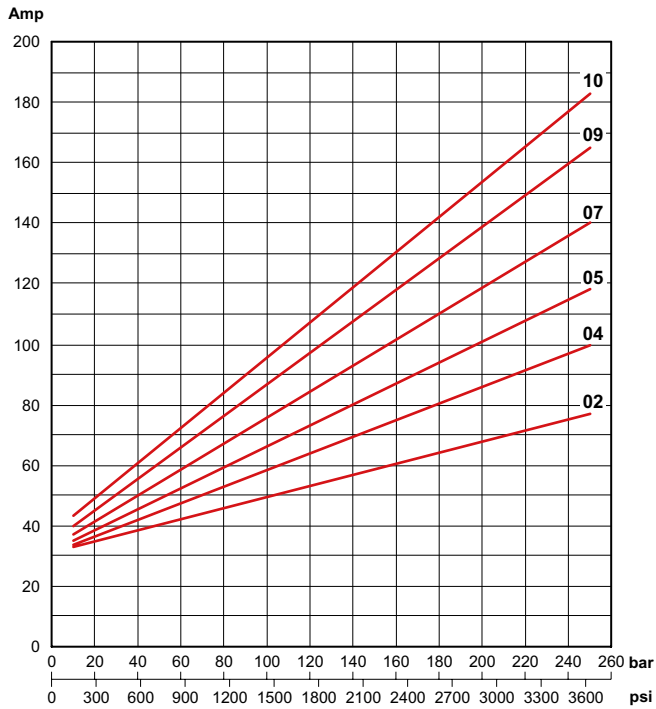

**Current with GR05 / GR1 pumps**  
Displacement 1.2 ÷ 7.8 cc/rev [0.073 ÷ 0.476 in<sup>3</sup>/rev]

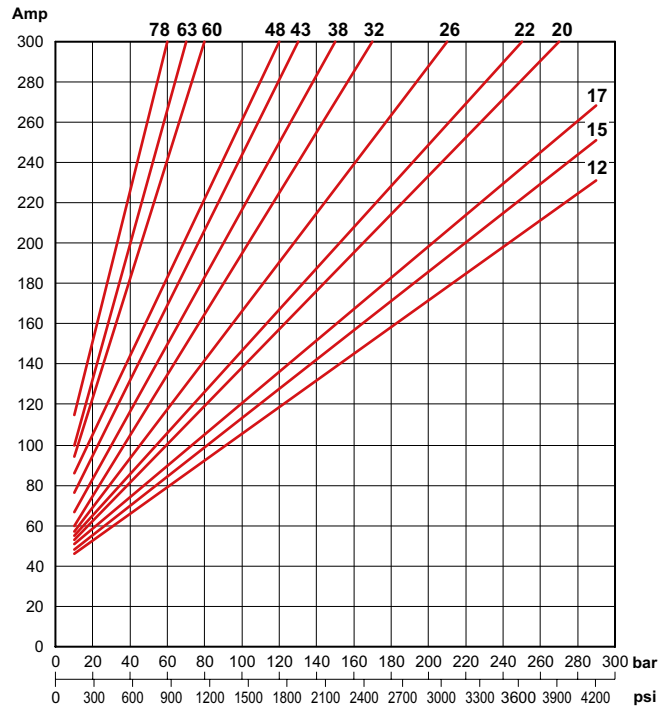

### Thermal characteristics S2 - S3

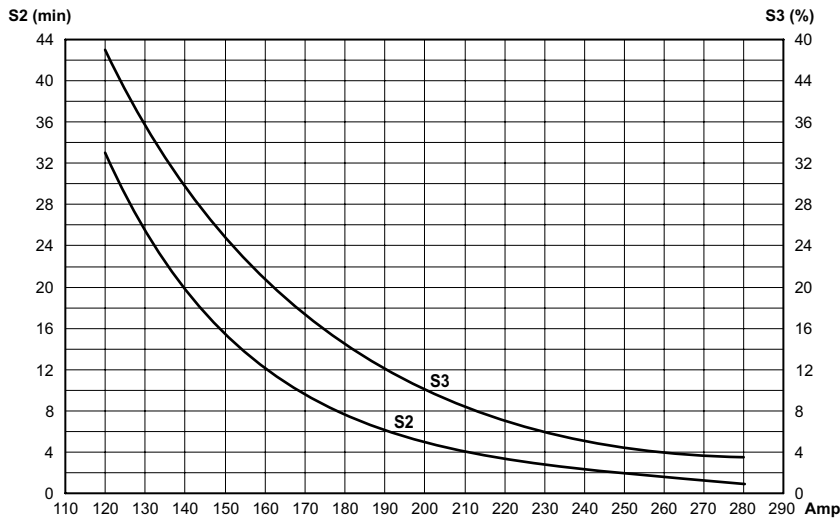

Motor with thermal switch

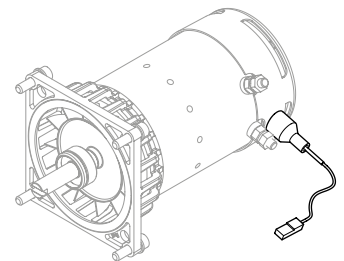

### ORDERING CODE

Power pack	X mm [inch]	Code Fan cooled motor	Code Fan cooled motor with thermal switch	Code Fan cooled kit
FP	52.6 [2.07]	KIT09008.061	KIT09008.062	25017800
MC	41.6 [1.64]	KIT01008.065	KIT01008.088	25002300

Code	Description
KIT07012.033	Starting switch kit 12VDC - 120A (fixing with clamp)

Reference data: maximum nominal pressure Pmax = 290 bar. Oil ISO VG32 temperature 35°C (viscosity 40 cSt), outside temperature 25°C.

Maximum nominal current Imax = 300A. Stabilized voltage to 12 Vdc detected at the terminals of the electric motor.

## 24 VDC - 2.0 KW - D.115 MOTOR

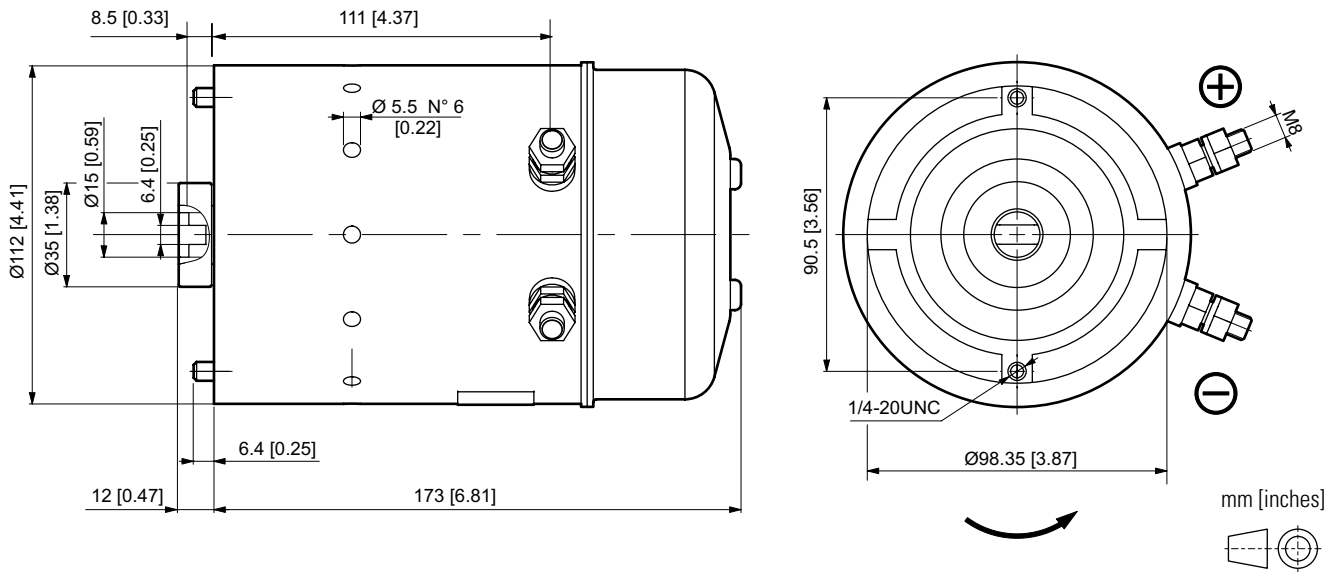

### RATED FEATURES

Voltage	24 VDC
Power	2.0 kW
Nominal diameter	115 mm [4.53 in]
Motor type	Wound field compound
Rotation	CCW
Protection class IP (with motor assembled on hydraulic power pack)	54
S2 / S3 duty service	see curves
Insulation class	F
Weight	6.7 kg [14.77 lb]

### PUMP TYPE

Code	cc/rev.	GR (Size)
<b>02</b>	0.25	05
<b>04</b>	0.45	05
<b>05</b>	0.56	05
<b>07</b>	0.75	05/1
<b>09</b>	0.9	05/1
<b>10</b>	1.0	05/1
<b>12</b>	1.2	05/1
<b>15</b>	1.5	1
<b>17</b>	1.7	1
<b>20</b>	2.0	1

  

Code	cc/rev.	GR (Size)
<b>22</b>	2.2	1
<b>26</b>	2.6	1
<b>32</b>	3.2	1
<b>38</b>	3.8	1
<b>43</b>	4.3	1
<b>48</b>	4.8	1
<b>60</b>	6.0	1
<b>63</b>	6.3	1
<b>78</b>	7.8	1

Performance with GR05 / GR1 pumps  
Displacement 0.2 ÷ 1.0 cc/rev [0.012 ÷ 0.061 in<sup>3</sup>/rev]

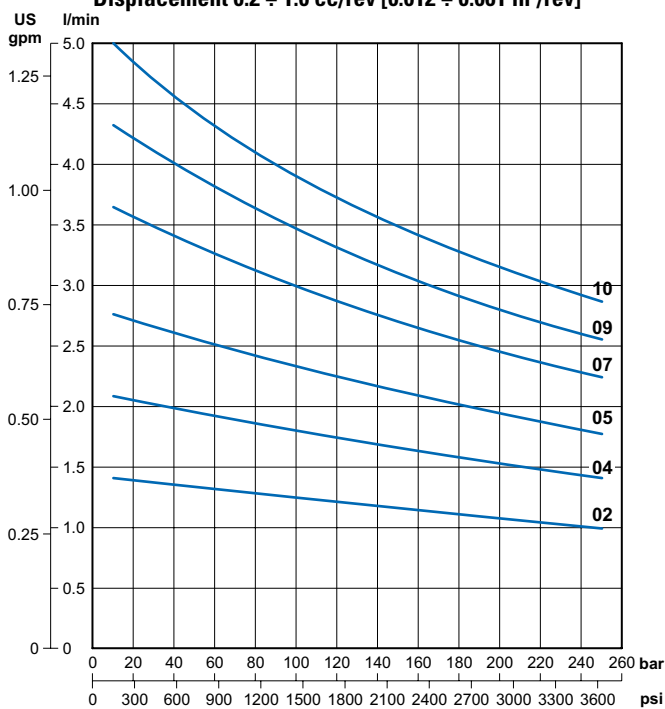

Performance with GR05 / GR1 pumps  
Displacement 1.2 ÷ 7.8 cc/rev [0.073 ÷ 0.476 in<sup>3</sup>/rev]

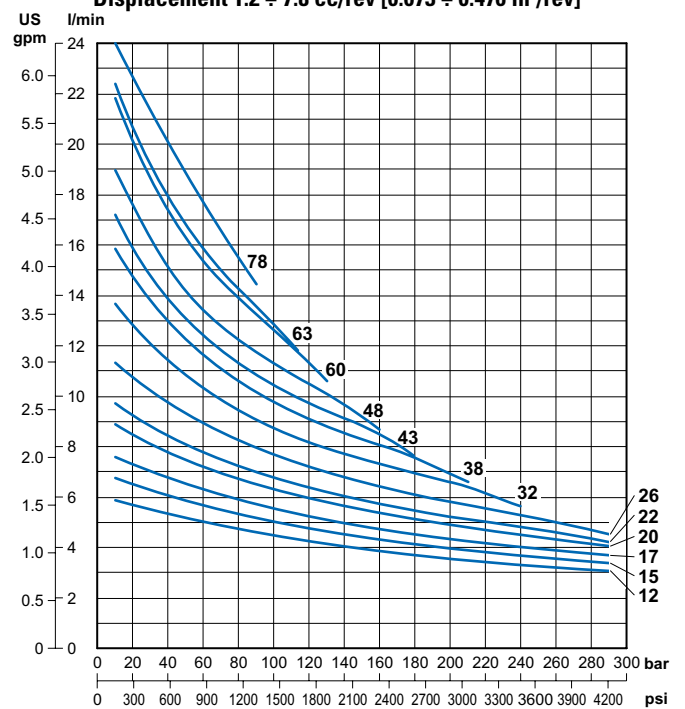

**Current with GR05 / GR1 pumps**  
Displacement 0.2 ÷ 1.0 cc/rev [0.012 ÷ 0.061 in<sup>3</sup>/rev]

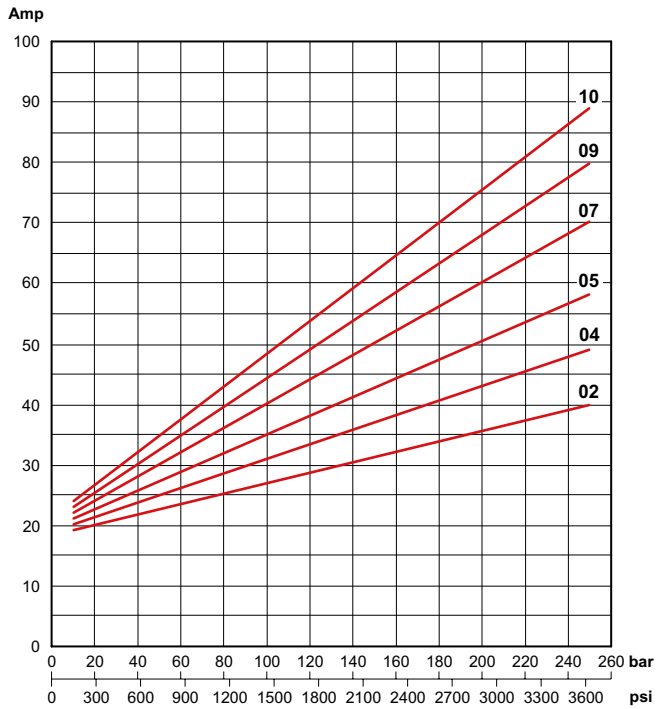

**Current with GR05 / GR1 pumps**  
Displacement 1.2 ÷ 7.8 cc/rev [0.073 ÷ 0.476 in<sup>3</sup>/rev]

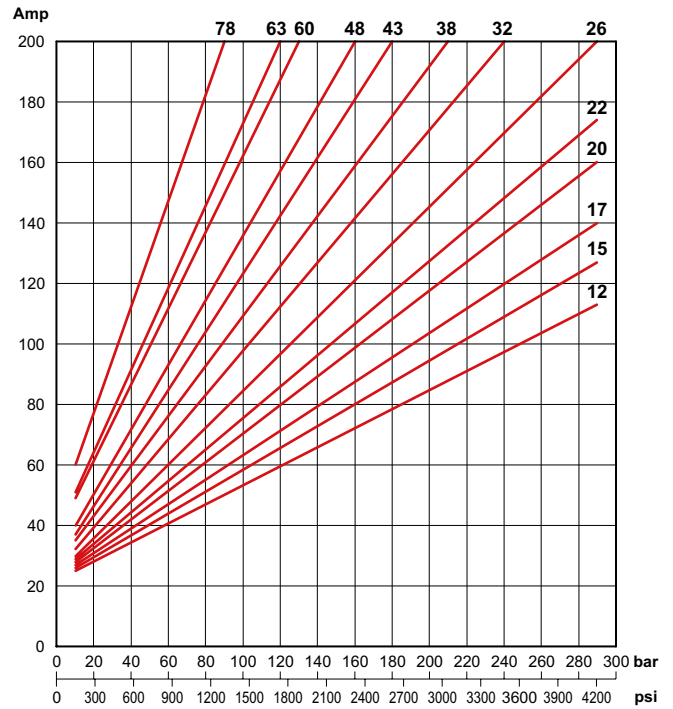

### Thermal characteristics S2 - S3

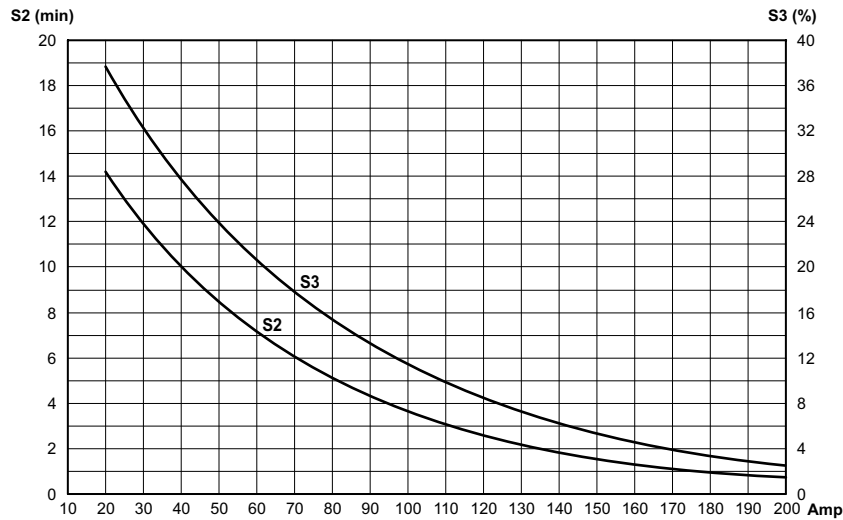

### ORDERING CODE

Code	Description
<b>25022300</b>	24VDC motor - 2.0 kW

Code	Description
<b>KIT07012.034</b>	Starting switch kit 24VDC - 120A (fixing with clamp)

Reference data: maximum nominal pressure Pmax = 290 bar. Oil ISO VG32 temperature 35°C (viscosity 40 cSt), outside temperature 25°C.

Maximum nominal current Imax = 200A. Stabilized voltage to 24 Vdc detected at the terminals of the electric motor.



# 25022300 FAN



**Current with GR05 / GR1 pumps**  
Displacement 0.2 ÷ 1.0 cc/rev [0.012 ÷ 0.061 in<sup>3</sup>/rev]

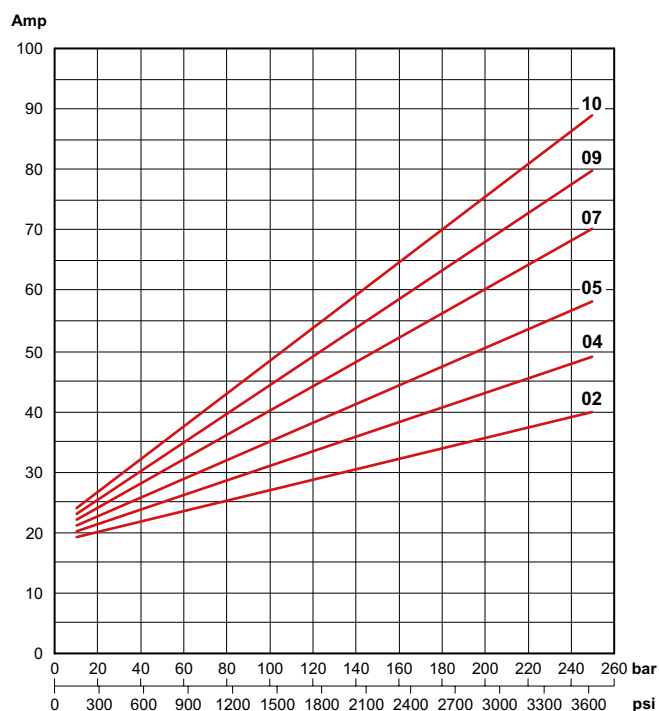

**Current with GR05 / GR1 pumps**  
Displacement 1.2 ÷ 7.8 cc/rev [0.073 ÷ 0.476 in<sup>3</sup>/rev]

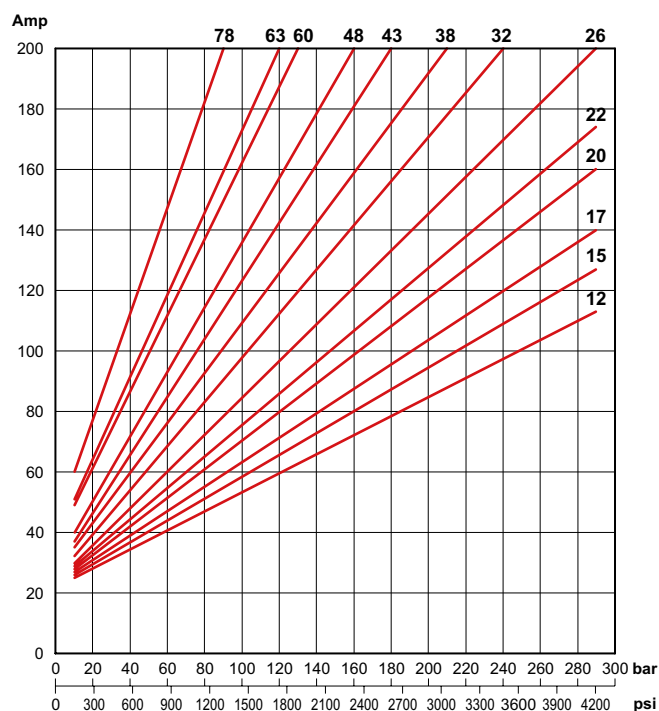

## Thermal characteristics S2 - S3

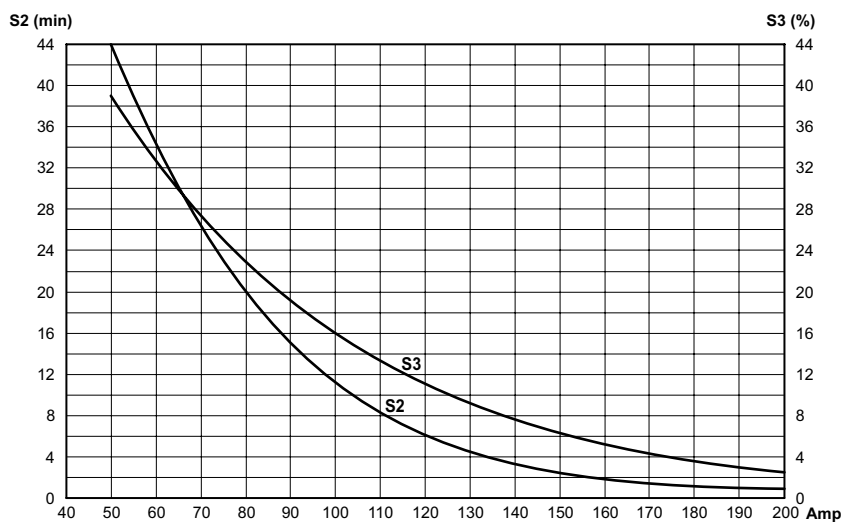

Motor with thermal switch

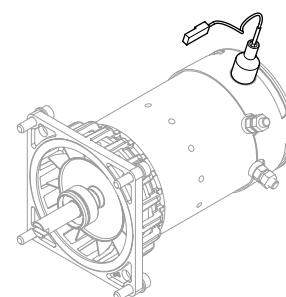

## ORDERING CODE

Power pack	X mm [inch]	Code Fan cooled motor	Code Fan cooled motor with thermal switch	Code Fan cooled kit
FP	52.6 [2.07]	KIT09008.031	KIT09008.063	25017800
MC	41.6 [1.64]	KIT01008.067	KIT01008.077	25002300

Code	Description
KIT07012.034	Starting switch kit 24VDC - 120A (fixing with clamp)

Reference data: maximum nominal pressure Pmax = 290 bar. Oil ISO VG32 temperature 35°C (viscosity 40 cSt), outside temperature 25°C.

Maximum nominal current Imax = 200A. Stabilized voltage to 24 Vdc detected at the terminals of the electric motor.

# 25022000



## 12 VDC - 1.6 KW - D.115 MOTOR

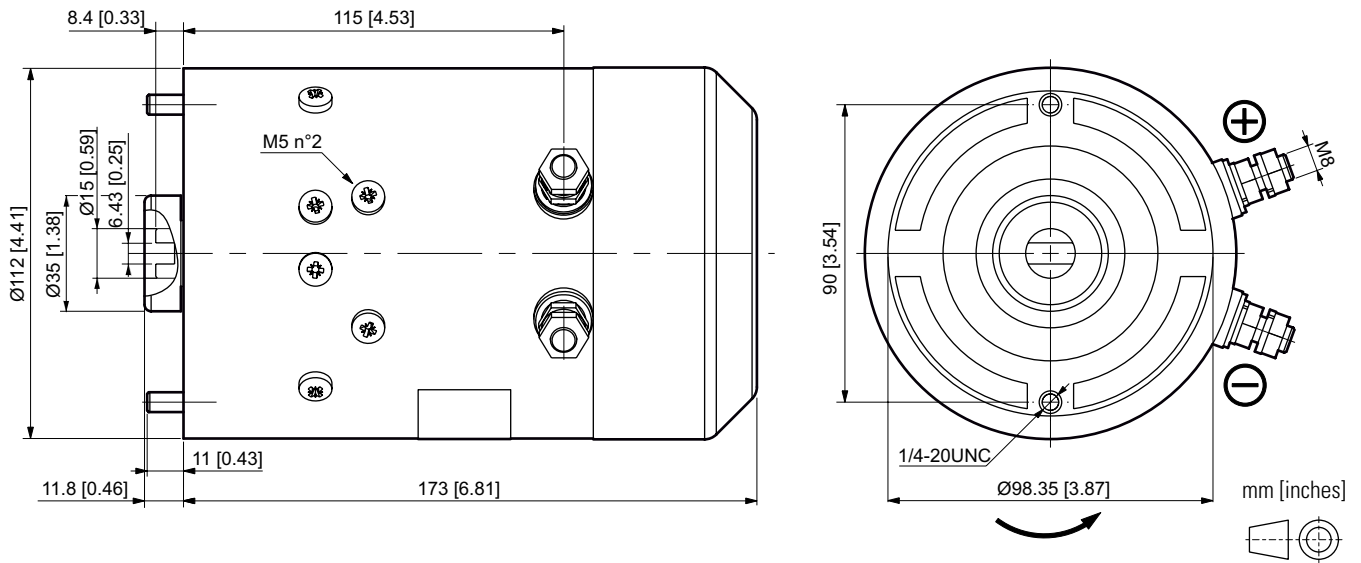

### RATED FEATURES

Voltage	12 VDC
Power	1.6 kW
Nominal diameter	115 mm [4.53 in]
Motor type	Wound field compound
Rotation	CCW
Protection class IP (with motor assembled on hydraulic power pack)	54
S2 / S3 duty service	see curves
Insulation class	F
Weight	6.7 kg [14.77 lb]

### PUMP TYPE

Code	cc/rev.	GR (Size)
<b>02</b>	0.25	05
<b>04</b>	0.45	05
<b>05</b>	0.56	05
<b>07</b>	0.75	05/1
<b>09</b>	0.9	05/1
<b>10</b>	1.0	05/1
<b>12</b>	1.2	05/1
<b>15</b>	1.5	1
<b>17</b>	1.7	1
<b>20</b>	2.0	1

Code	cc/rev.	GR (Size)
<b>22</b>	2.2	1
<b>26</b>	2.6	1
<b>32</b>	3.2	1
<b>38</b>	3.8	1
<b>43</b>	4.3	1
<b>48</b>	4.8	1
<b>60</b>	6.0	1
<b>63</b>	6.3	1
<b>78</b>	7.8	1

Performance with GR05 / GR1 pumps  
Displacement 0.2 ÷ 1.0 cc/rev [0.012 ÷ 0.061 in<sup>3</sup>/rev]

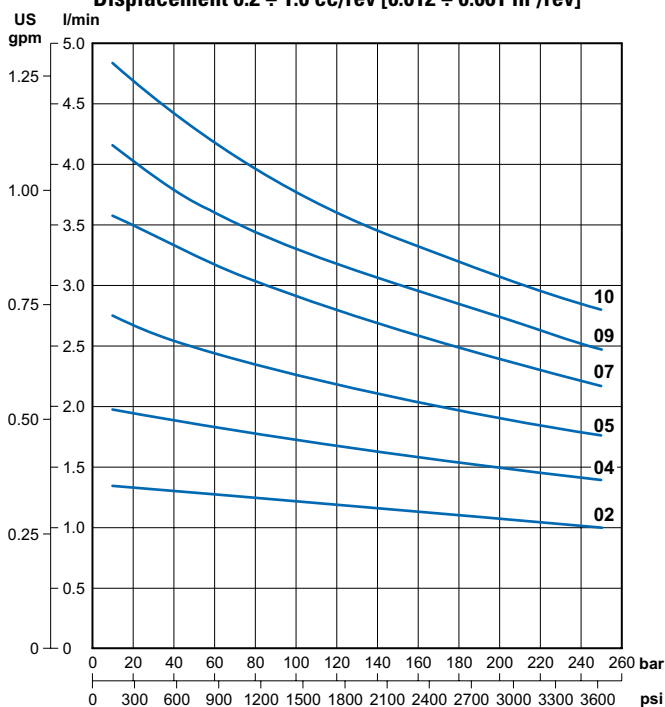

Performance with GR05 / GR1 pumps  
Displacement 1.2 ÷ 7.8 cc/rev [0.073 ÷ 0.476 in<sup>3</sup>/rev]

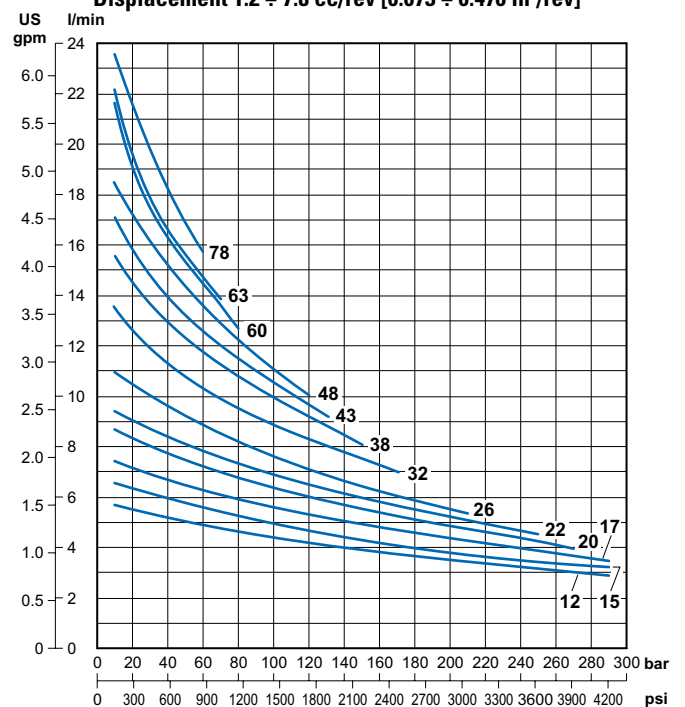

**Current with GR05 / GR1 pumps**  
Displacement 0.2 ÷ 1.0 cc/rev [0.012 ÷ 0.061 in<sup>3</sup>/rev]

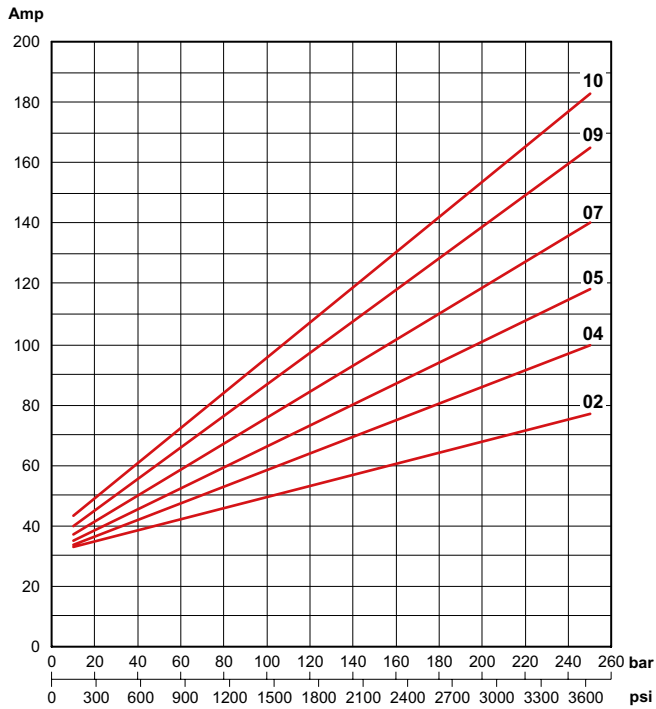

**Current with GR05 / GR1 pumps**  
Displacement 1.2 ÷ 7.8 cc/rev [0.073 ÷ 0.476 in<sup>3</sup>/rev]

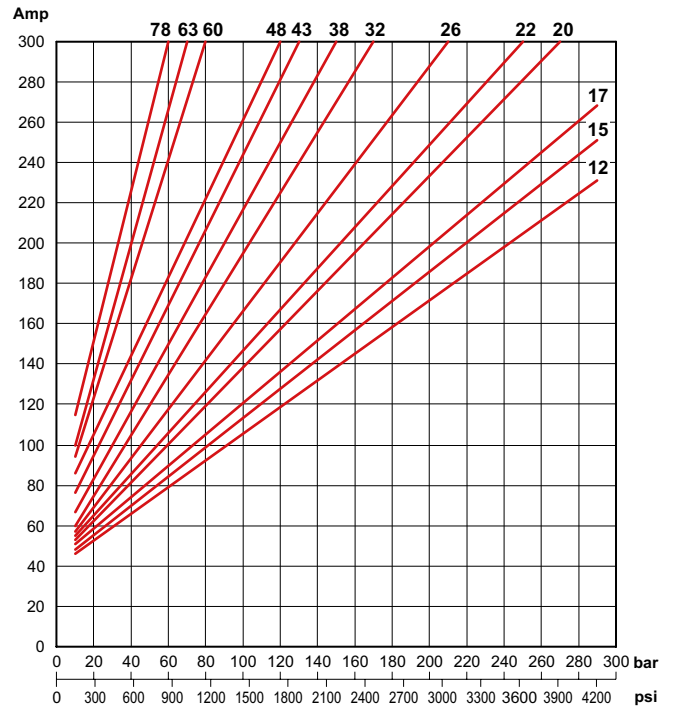

### Thermal characteristics S2 - S3

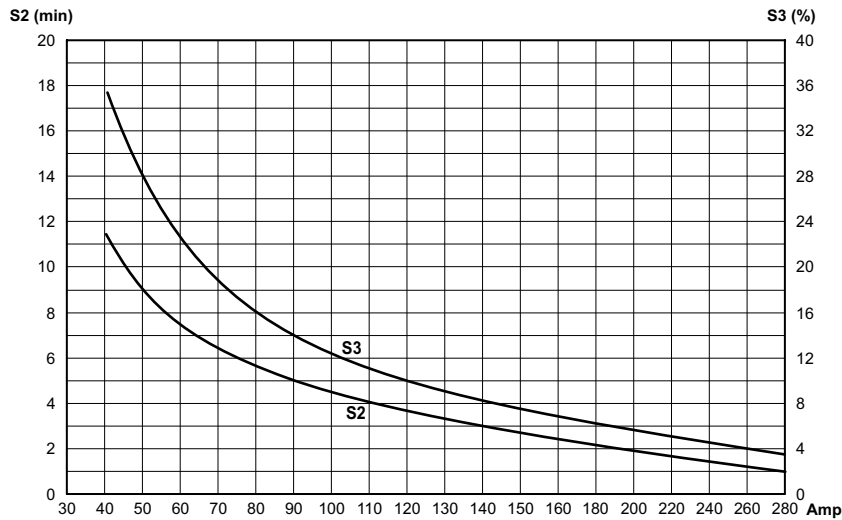

### ORDERING CODE

Code	Description
<b>25022000</b>	24VDC motor - 1.6 kW

Code	Description
<b>KIT07012.025</b>	Starting switch kit 12VDC - 120A (fixing with screws)

Reference data: maximum nominal pressure Pmax = 290 bar. Oil ISO VG32 temperature 35°C (viscosity 40 cSt), outside temperature 25°C.

Maximum nominal current Imax = 300A. Stabilized voltage to 12 Vdc detected at the terminals of the electric motor.

## 24 VDC - 2.2 KW - D.115 MOTOR

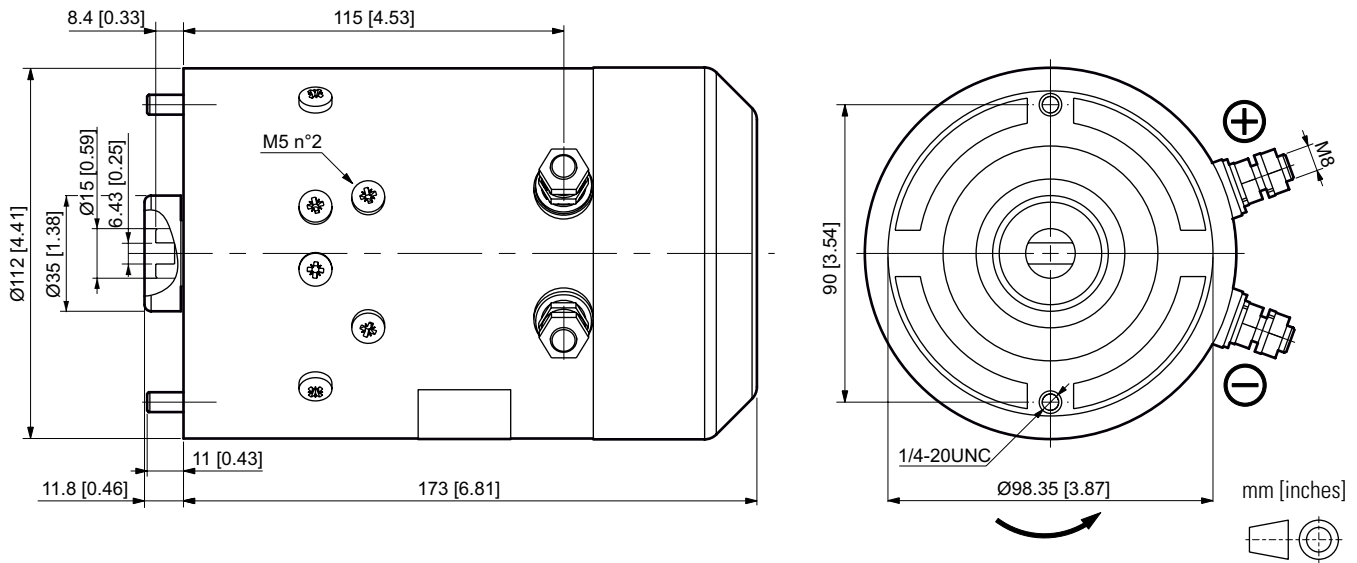

### RATED FEATURES

Voltage	24 VDC
Power	2.2 kW
Nominal diameter	115 mm [4.53 in]
Motor type	Wound field compound
Rotation	CCW
Protection class IP (with motor assembled on hydraulic power pack)	54
S2 / S3 duty service	see curves
Insulation class	F
Weight	6.7 kg [14.77 lb]

### PUMP TYPE

Code	cc/rev.	GR (Size)
<b>02</b>	0.25	05
<b>04</b>	0.45	05
<b>05</b>	0.56	05
<b>07</b>	0.75	05/1
<b>09</b>	0.9	05/1
<b>10</b>	1.0	05/1
<b>12</b>	1.2	05/1
<b>15</b>	1.5	1
<b>17</b>	1.7	1
<b>20</b>	2.0	1

Code	cc/rev.	GR (Size)
<b>22</b>	2.2	1
<b>26</b>	2.6	1
<b>32</b>	3.2	1
<b>38</b>	3.8	1
<b>43</b>	4.3	1
<b>48</b>	4.8	1
<b>60</b>	6.0	1
<b>63</b>	6.3	1
<b>78</b>	7.8	1

Performance with GR05 / GR1 pumps  
Displacement 0.2 ÷ 1.0 cc/rev [0.012 ÷ 0.061 in<sup>3</sup>/rev]

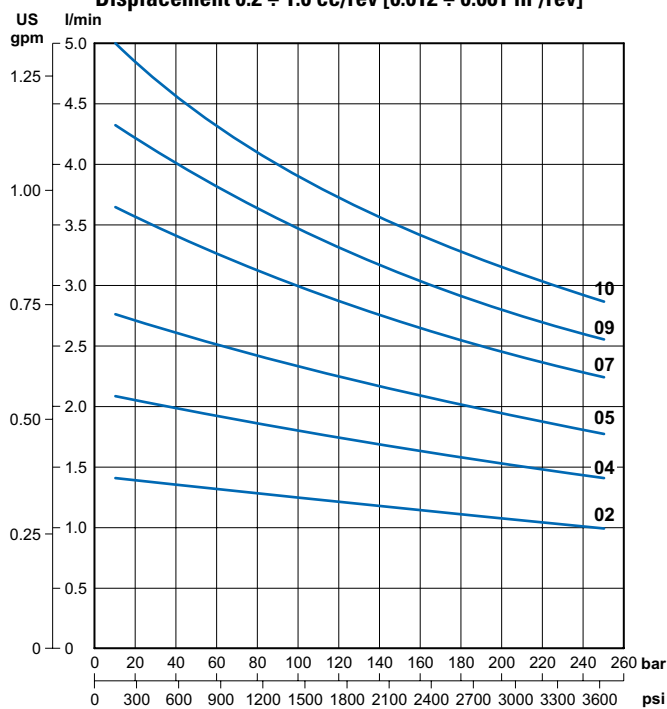

Performance with GR05 / GR1 pumps  
Displacement 1.2 ÷ 7.8 cc/rev [0.073 ÷ 0.476 in<sup>3</sup>/rev]

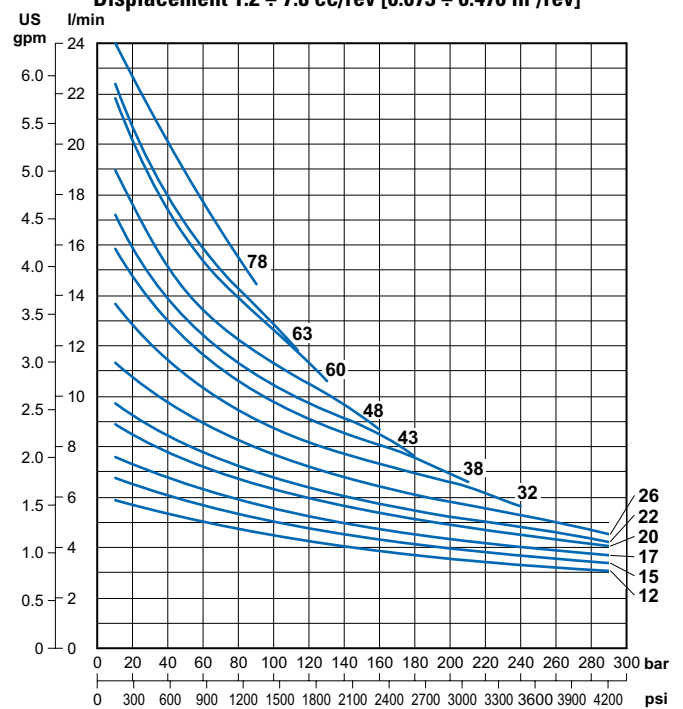

**Current with GR05 / GR1 pumps**  
Displacement 0.2 ÷ 1.0 cc/rev [0.012 ÷ 0.061 in<sup>3</sup>/rev]

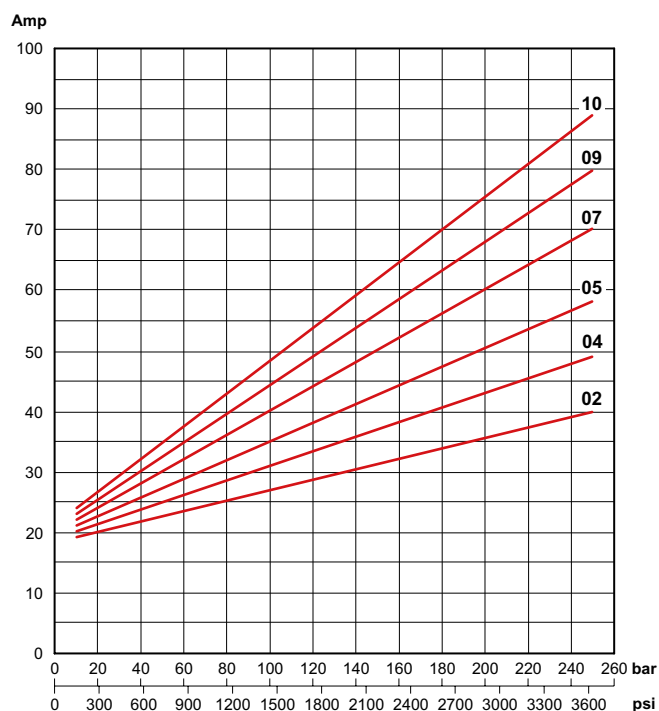

**Current with GR05 / GR1 pumps**  
Displacement 1.2 ÷ 7.8 cc/rev [0.073 ÷ 0.476 in<sup>3</sup>/rev]

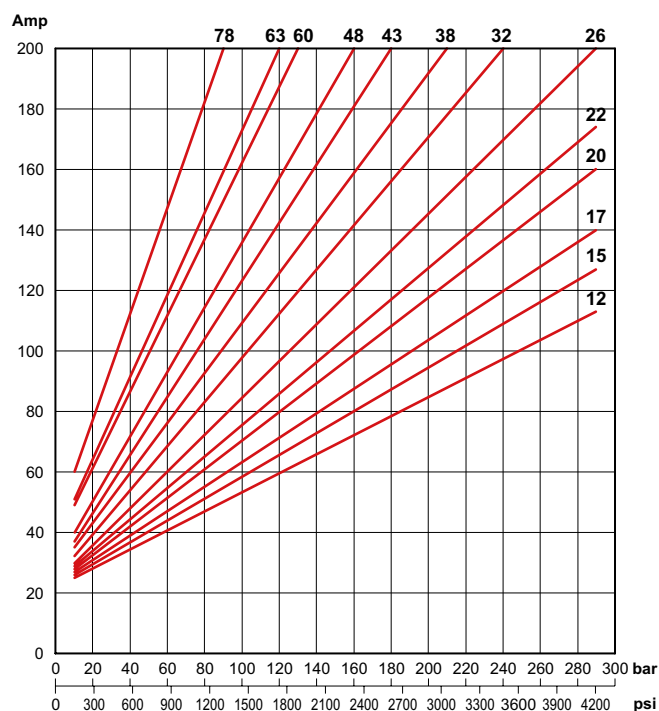

### Thermal characteristics S2 - S3

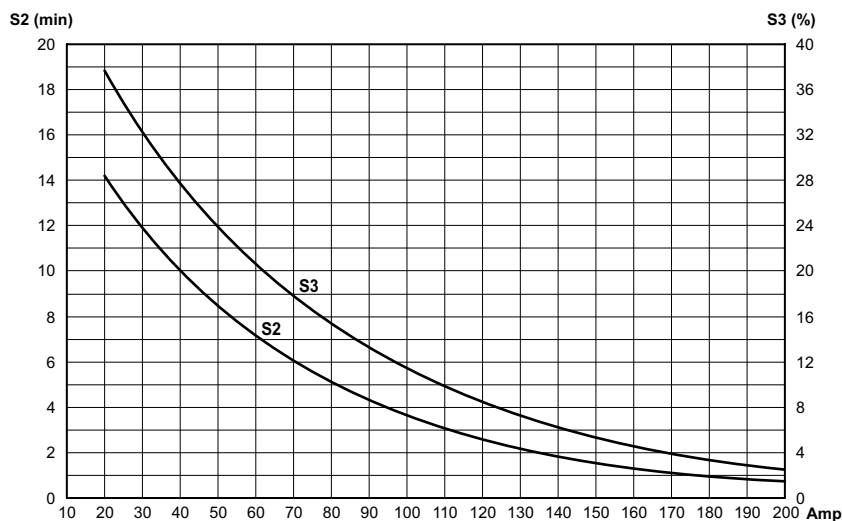

### ORDERING CODE

Code	Description
<b>25022100</b>	24VDC motor - 2.2 kW

Code	Description
<b>KIT07012.026</b>	Starting switch kit 24VDC - 120A (fixing with screws)

Reference data: maximum nominal pressure Pmax = 290 bar. Oil ISO VG32 temperature 35°C (viscosity 40 cSt), outside temperature 25°C.

Maximum nominal current Imax = 200A. Stabilized voltage to 24 Vdc detected at the terminals of the electric motor.

# 25022600



## 12 VDC - 1.6 KW - D.115 MOTOR

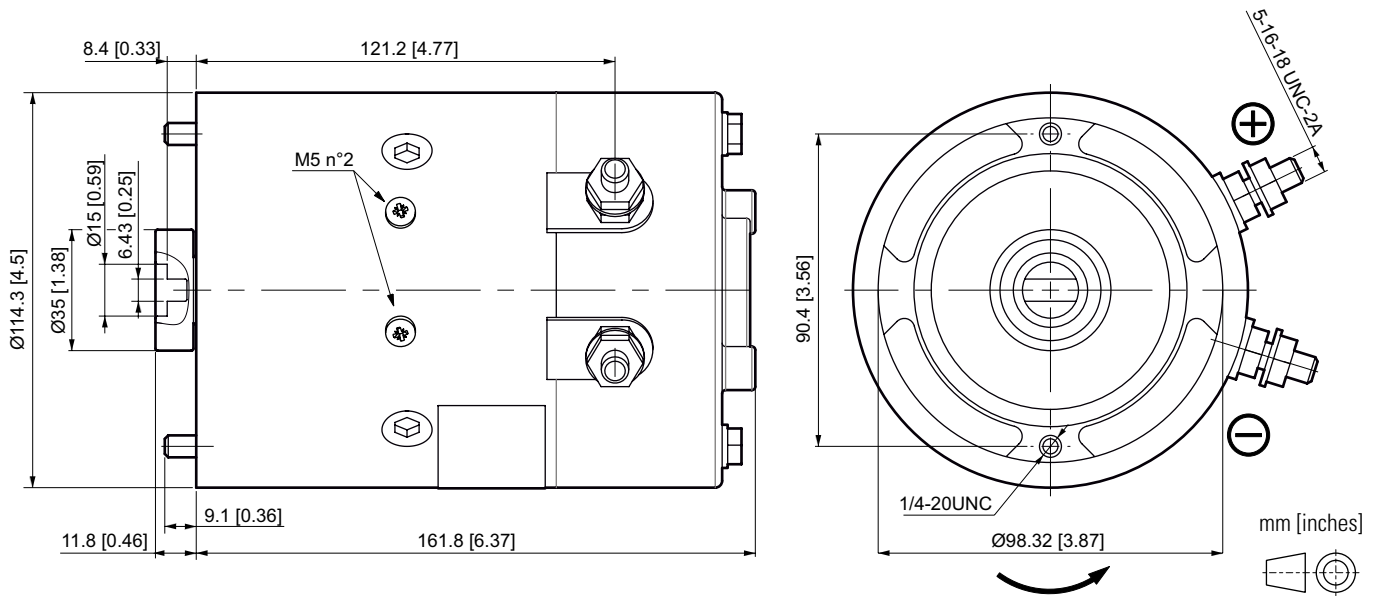

### RATED FEATURES

Voltage	12 VDC
Power	1.6 kW
Nominal diameter	115 mm [4.53 in]
Motor type	Serie "U" (USA)
Rotation	CCW
Protection class IP (with motor assembled on hydraulic power pack)	54
S2 / S3 duty service	see curves
Insulation class	F
Weight	6.7 kg [14.77 lb]

### PUMP TYPE

Code	cc/rev.	GR (Size)
<b>02</b>	0.25	05
<b>04</b>	0.45	05
<b>05</b>	0.56	05
<b>07</b>	0.75	05/1
<b>09</b>	0.9	05/1
<b>10</b>	1.0	05/1
<b>12</b>	1.2	05/1
<b>15</b>	1.5	1
<b>17</b>	1.7	1
<b>20</b>	2.0	1

Code	cc/rev.	GR (Size)
<b>22</b>	2.2	1
<b>26</b>	2.6	1
<b>32</b>	3.2	1
<b>38</b>	3.8	1
<b>43</b>	4.3	1
<b>48</b>	4.8	1
<b>60</b>	6.0	1

**Performance with GR05 / GR1 pumps**  
Displacement 0.2 ÷ 1.0 cc/rev [0.012 ÷ 0.061 in<sup>3</sup>/rev]

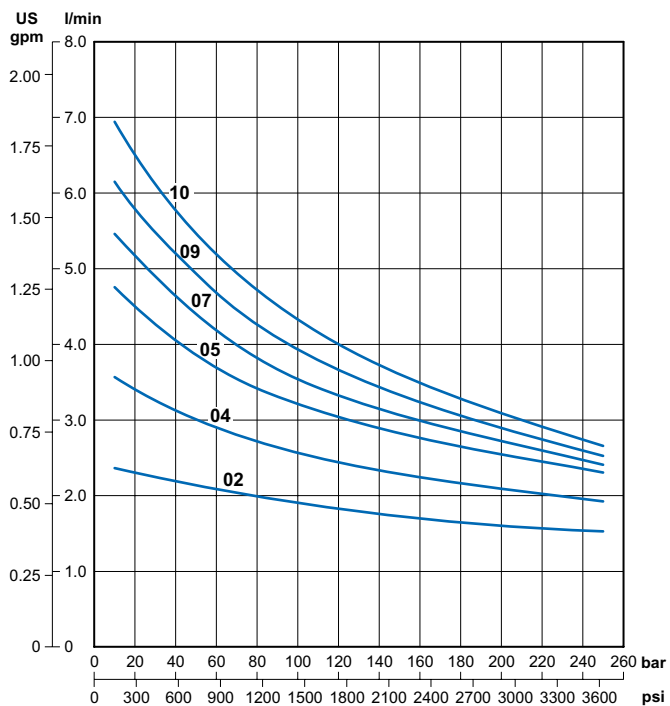

**Performance with GR05 / GR1 pumps**  
Displacement 1.2 ÷ 6.0 cc/rev [0.073 ÷ 0.366 in<sup>3</sup>/rev]

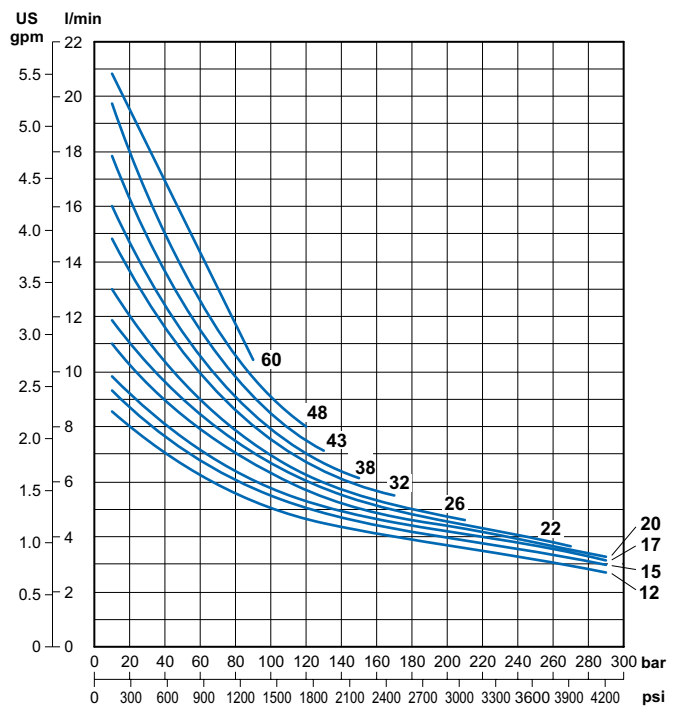

**Current with GR05 / GR1 pumps**  
Displacement 0.2 ÷ 1.0 cc/rev [0.012 ÷ 0.061 in<sup>3</sup>/rev]

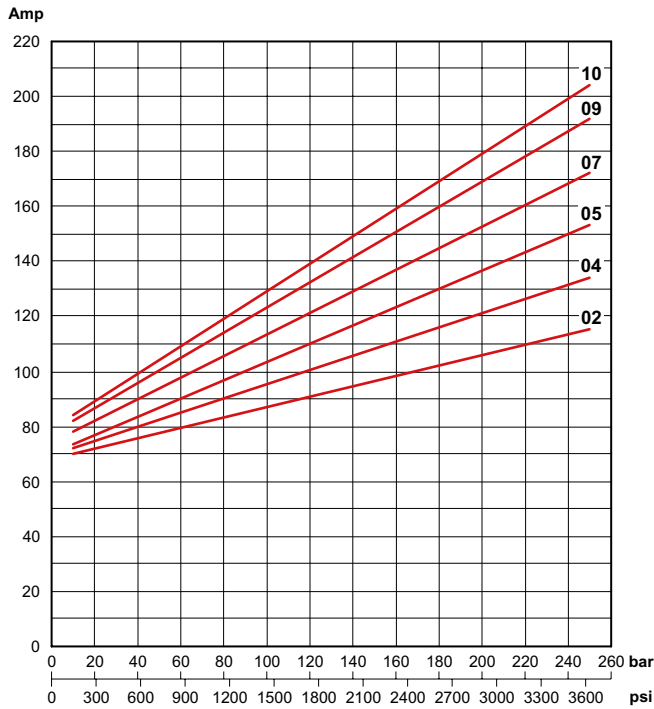

**Current with GR05 / GR1 pumps**  
Displacement 1.2 ÷ 6.0 cc/rev [0.073 ÷ 0.366 in<sup>3</sup>/rev]

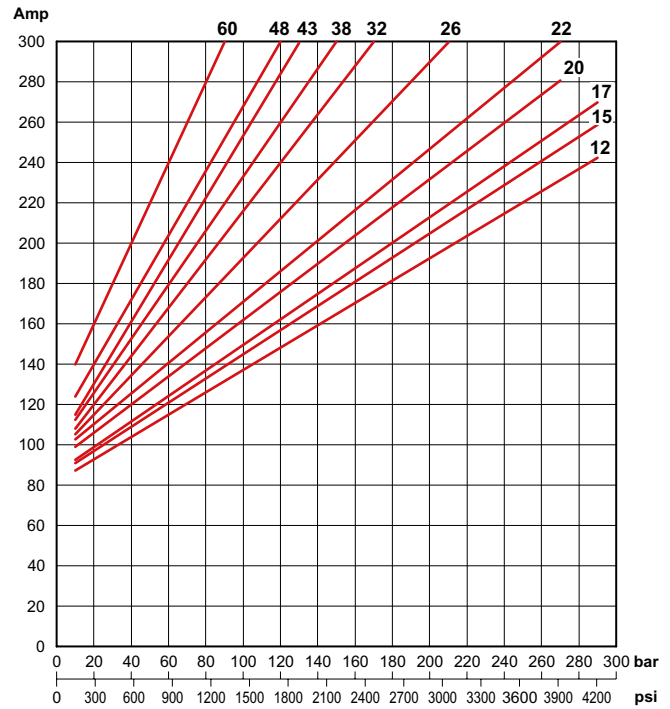

### Thermal characteristics S2 - S3

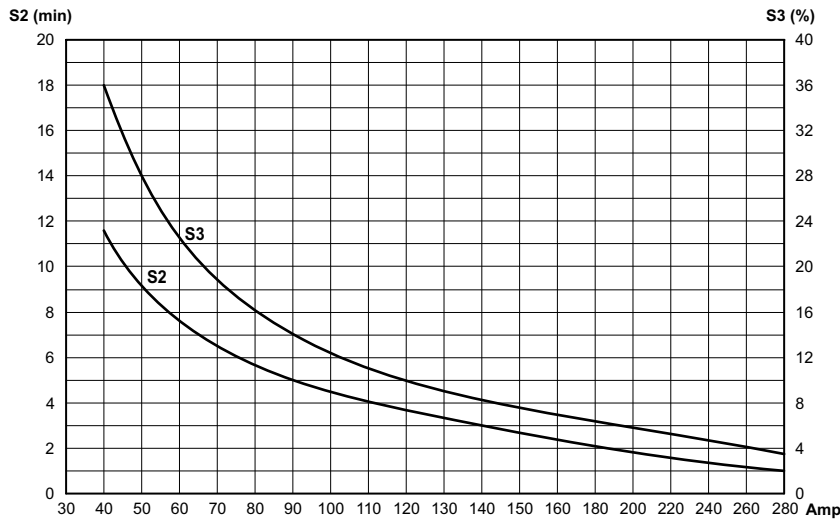

Motor with thermal switch

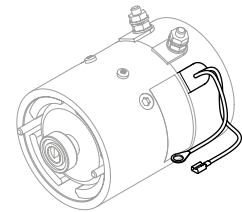

### ORDERING CODE

Code	Description
<b>25022600</b>	12VDC motor - 1.6 kW
<b>25022800</b>	12VDC motor - 1.6 kW with thermal switch

Code	Description
<b>KIT07012.025</b>	Starting switch kit 12VDC - 120A (fixing with screws)

Reference data: maximum nominal pressure Pmax = 290 bar. Oil ISO VG32 temperature 35°C (viscosity 40 cSt), outside temperature 25°C.

Maximum nominal current Imax = 300A. Stabilized voltage to 12 Vdc detected at the terminals of the electric motor.

## 24 VDC- 2.2 KW - D.115 MOTOR

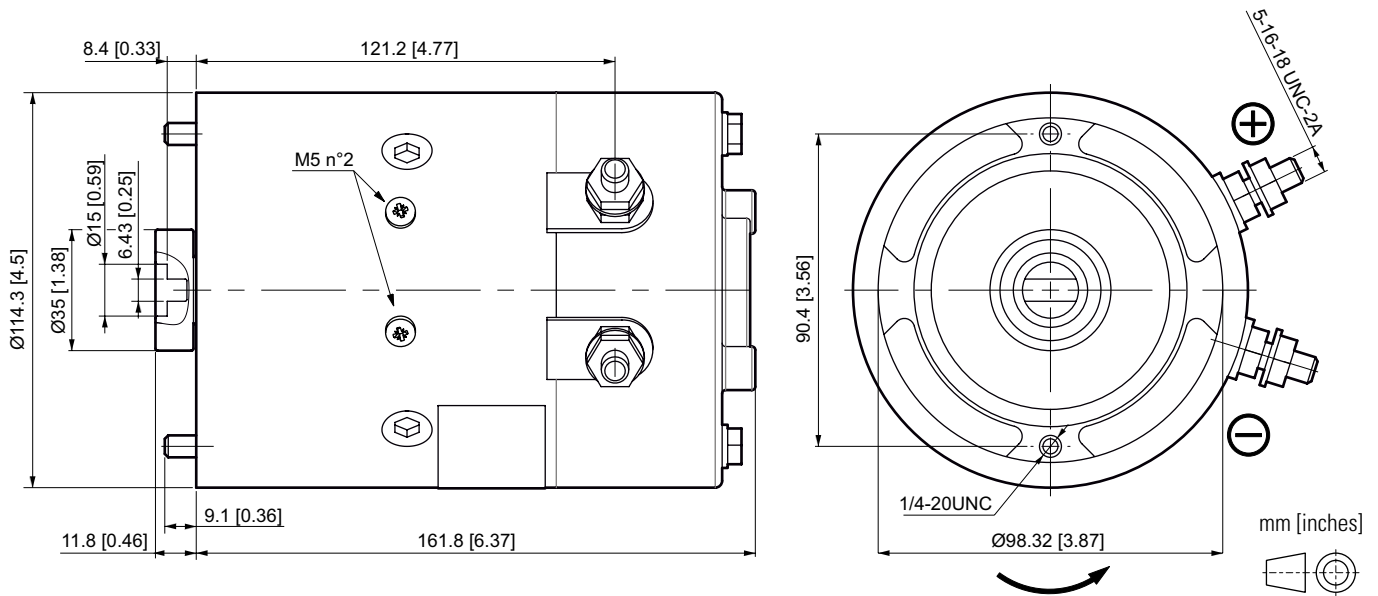

### RATED FEATURES

Voltage	24 VDC
Power	2.2 kW
Nominal diameter	115 mm [4.53 in]
Motor type	Serie "U" (USA)
Rotation	CCW
Protection class IP (with motor assembled on hydraulic power pack)	54
S2 / S3 duty service	see curves
Insulation class	F
Weight	6.7 kg [14.77 lb]

### PUMP TYPE

Code	cc/rev.	GR (Size)
<b>02</b>	0.25	05
<b>04</b>	0.45	05
<b>05</b>	0.56	05
<b>07</b>	0.75	05/1
<b>09</b>	0.9	05/1
<b>10</b>	1.0	05/1
<b>12</b>	1.2	05/1
<b>15</b>	1.5	1
<b>17</b>	1.7	1
<b>20</b>	2.0	1

  

Code	cc/rev.	GR (Size)
<b>22</b>	2.2	1
<b>26</b>	2.6	1
<b>32</b>	3.2	1
<b>38</b>	3.8	1
<b>43</b>	4.3	1
<b>48</b>	4.8	1
<b>60</b>	6.0	1

**Performance with GR05 / GR1 pumps**  
Displacement 0.2 ÷ 1.0 cc/rev [0.012 ÷ 0.061 in<sup>3</sup>/rev]

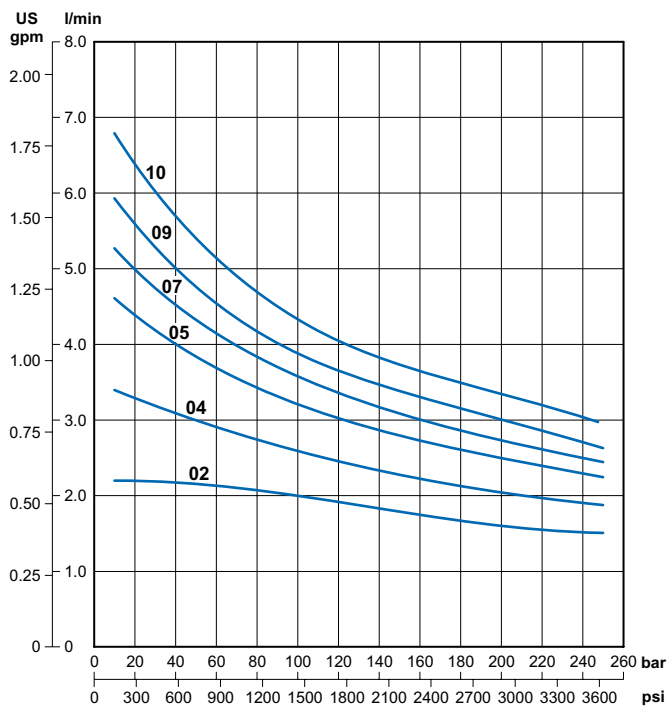

**Performance with GR05 / GR1 pumps**  
Displacement 1.2 ÷ 6.0 cc/rev [0.073 ÷ 0.366 in<sup>3</sup>/rev]

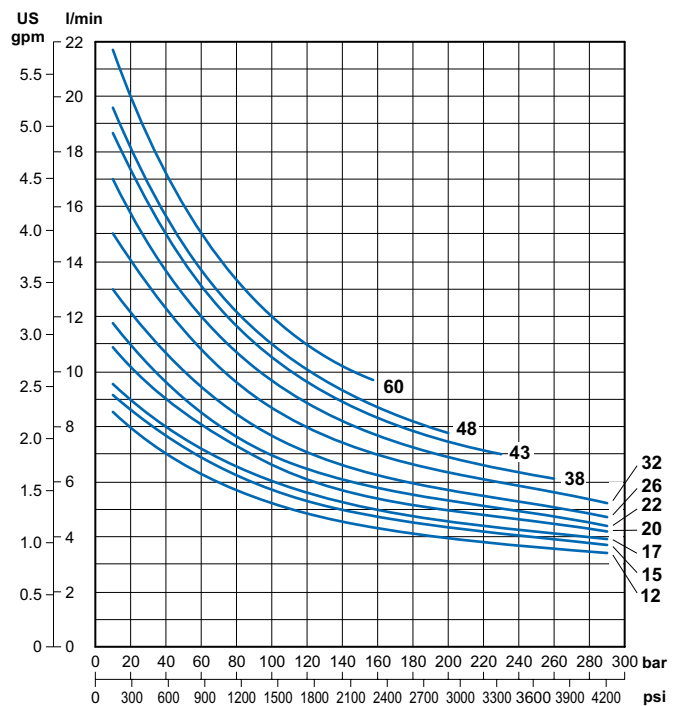

**Current with GR05 / GR1 pumps**  
Displacement 0.2 ÷ 1.0 cc/rev [0.012 ÷ 0.061 in<sup>3</sup>/rev]

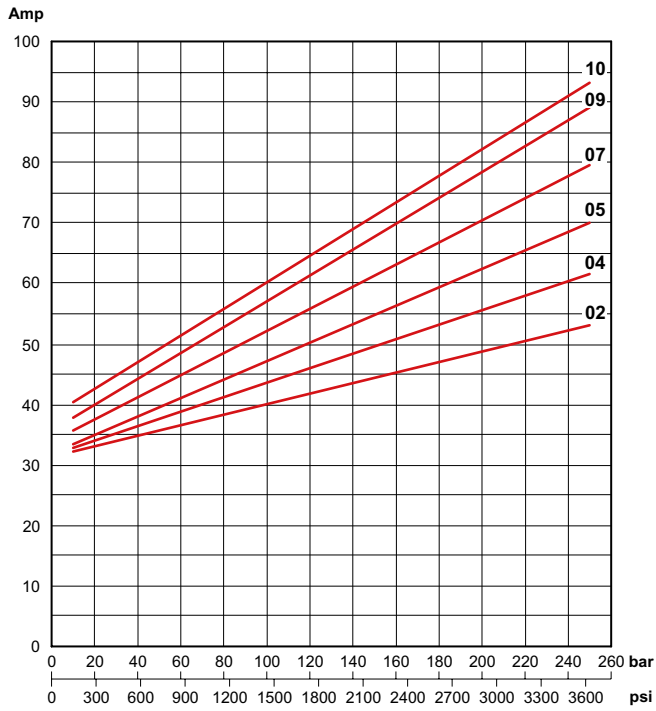

**Current with GR05 / GR1 pumps**  
Displacement 1.2 ÷ 6.0 cc/rev [0.073 ÷ 0.366 in<sup>3</sup>/rev]

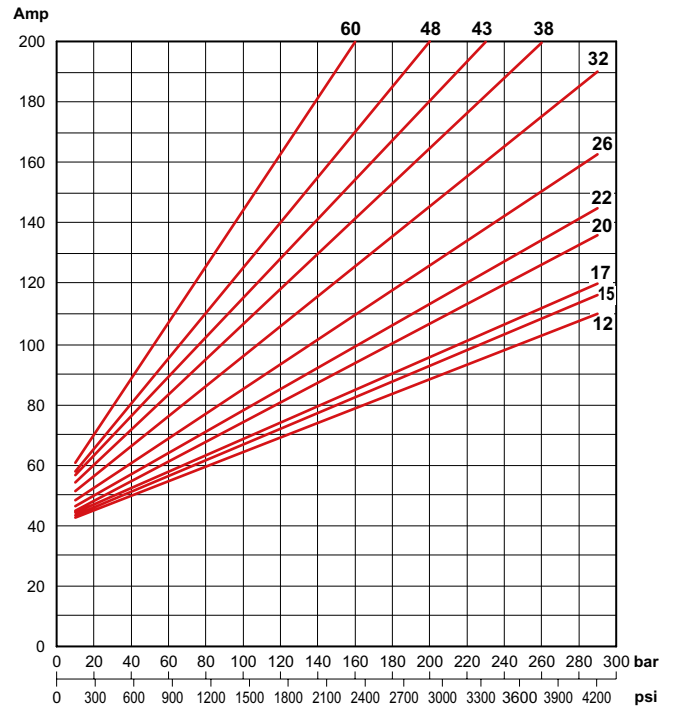

### Thermal characteristics S2 - S3

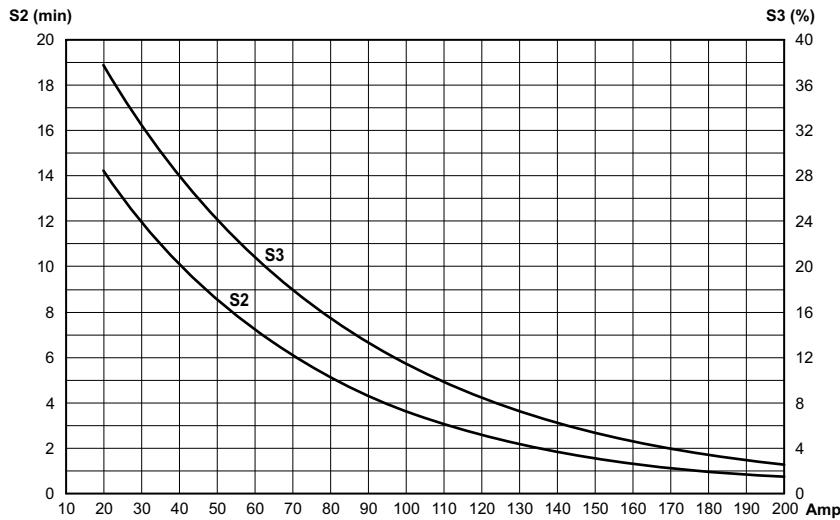

Motor with thermal switch

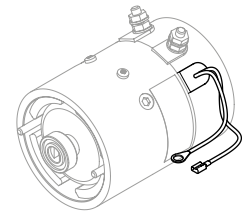

### ORDERING CODE

Code	Description
<b>25022700</b>	24VDC motor - 2.2 kW
<b>25022900</b>	24VDC motor - 2.2 kW with thermal switch

Code	Description
<b>KIT07012.026</b>	Starting switch kit 24VDC - 120A (fixing with screws)

Reference data: maximum nominal pressure Pmax = 290 bar. Oil ISO VG32 temperature 35°C (viscosity 40 cSt), outside temperature 25°C.

Maximum nominal current Imax = 200A. Stabilized voltage to 24 Vdc detected at the terminals of the electric motor.

# 25021300



## 24 VDC - 3.0 KW - D.125 MOTOR

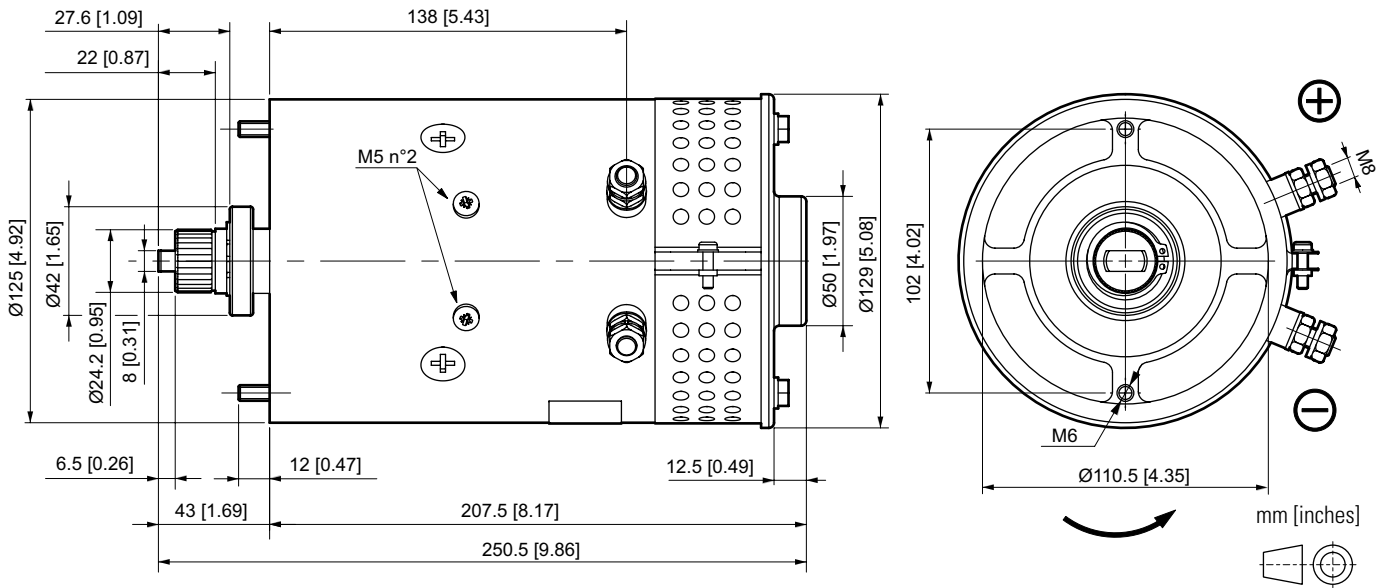

### RATED FEATURES

Voltage	24 VDC
Power	3.0 kW
Nominal diameter	125 mm [4.92 in]
Motor type	Wound field compound
Rotation	CCW
Protection class IP (with motor assembled on hydraulic power pack)	20
S2 / S3 duty service	see curves
Insulation class	F
Weight	12 kg [26.46 lb]

### PUMP TYPE

Code	cc/rev.	GR (Size)
09	0.9	05/1
10	1.0	05/1
12	1.2	05/1
15	1.5	1
17	1.7	1
20	2.0	1
22	2.2	1
26	2.6	1
32	3.2	1
38	3.8	1

  

Code	cc/rev.	GR (Size)
43	4.3	1
48	4.8	1
60	6.0	1
63	6.3	1
78	7.8	1

Performance with GR05 / GR1 pumps  
Displacement 0.9 ÷ 2.2 cc/rev [0.055 ÷ 0.134 in<sup>3</sup>/rev]

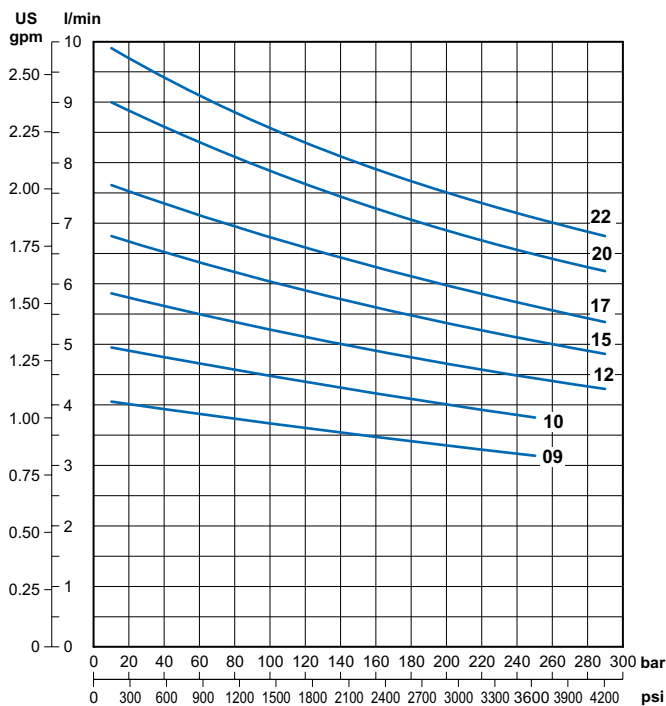

Performance with GR1 pumps  
Displacement 2.6 ÷ 7.8 cc/rev [0.159 ÷ 0.476 in<sup>3</sup>/rev]

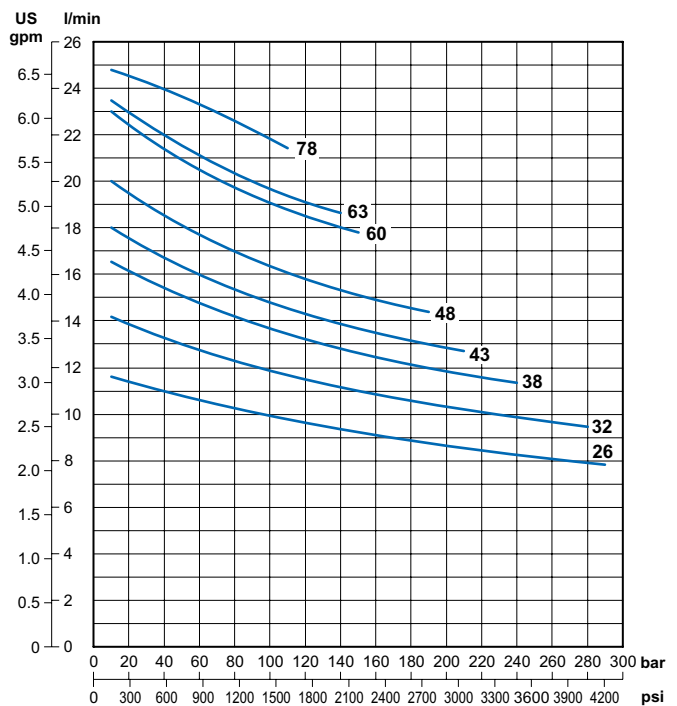

**Current with GR05 / GR1 pumps**  
Displacement 0.9 ÷ 2.2 cc/rev [0.055 ÷ 0.134 in<sup>3</sup>/rev]

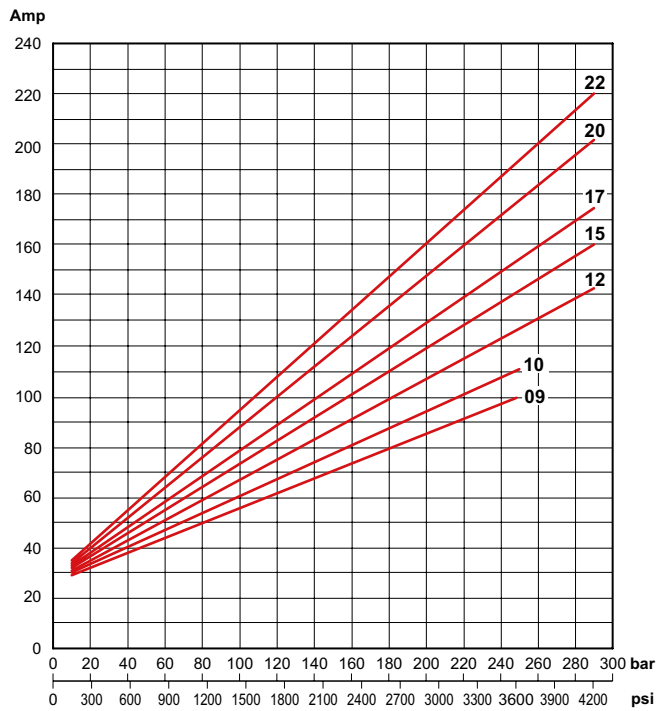

**Current with GR1 pumps**  
Displacement 2.6 ÷ 7.8 cc/rev [0.159 ÷ 0.476 in<sup>3</sup>/rev]

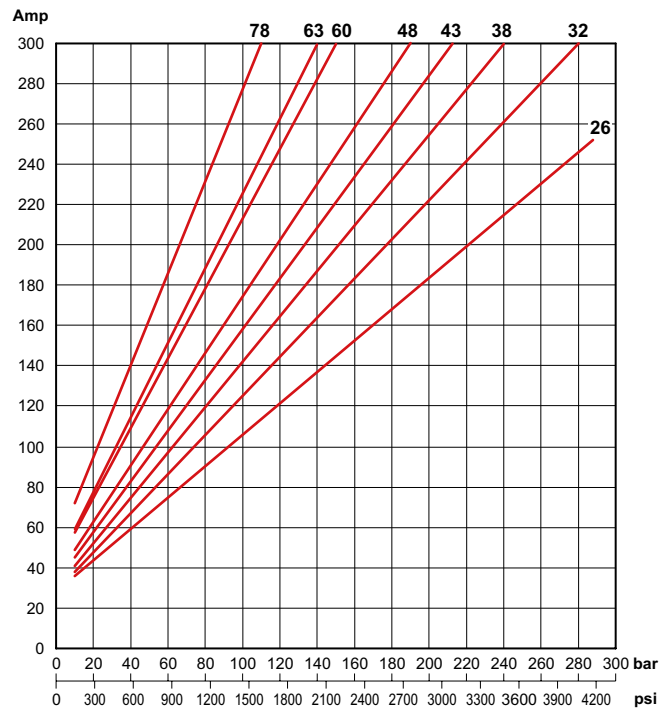

### Thermal characteristics S2 - S3

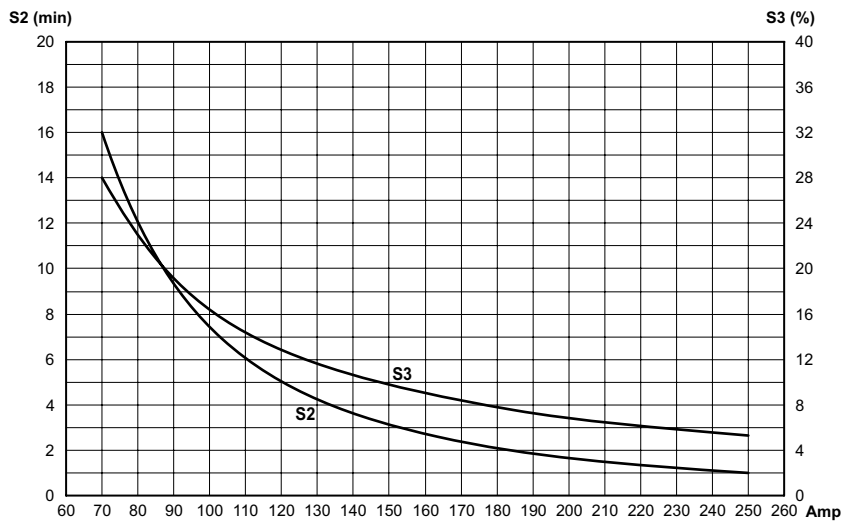

Motor with thermal switch

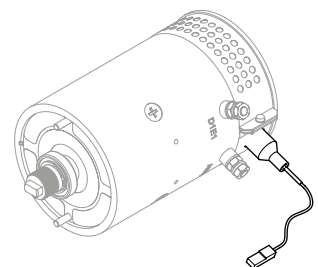

### ORDERING CODE

Code	Description
<b>25021300</b>	24VDC motor - 3.0 kW
<b>25023000</b>	24VDC motor - 3.0 kW with thermal switch
<b>25011600</b>	24VDC motor - 3.0 kW with adapter flange for MC/FP power pack

Code	Description
<b>KIT07012.019</b>	Starting switch kit 24VDC - 150A (fixing with screws)

Reference data: maximum nominal pressure Pmax = 290 bar. Oil ISO VG32 temperature 35°C (viscosity 40 cSt), outside temperature 25°C. Maximum nominal current Imax = 300A. Stabilized voltage to 24 Vdc detected at the terminals of the electric motor.

# 25021300 FAN



## 24 VDC - 3.0 KW - D.125 MOTOR

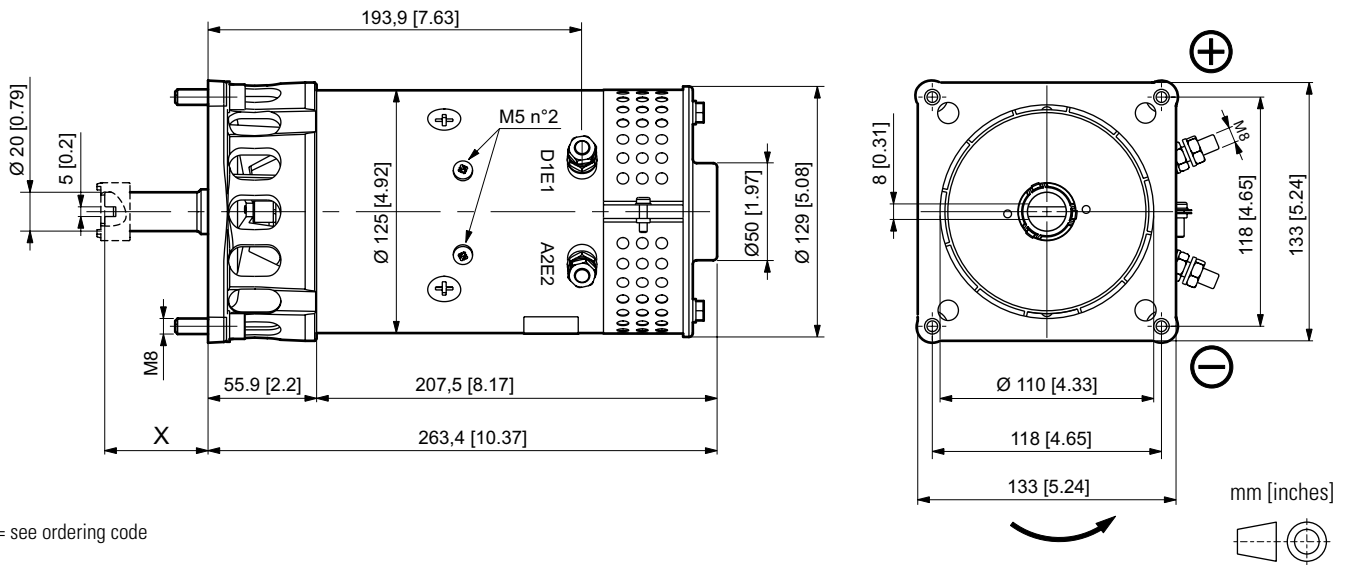

X = see ordering code

### RATED FEATURES

Voltage	24 VDC
Power	3.0 kW
Nominal diameter	125 mm [4.92 in]
Motor type	Wound field compound
Rotation	CCW
Protection class IP (with motor assembled on hydraulic power pack)	20
S2 / S3 duty service	see curves
Insulation class	F
Weight	13.1 kg [28.88 lb]

### PUMP TYPE

Code	cc/rev.	GR (Size)
<b>09</b>	0.9	05/1
<b>10</b>	1.0	05/1
<b>12</b>	1.2	05/1
<b>15</b>	1.5	1
<b>17</b>	1.7	1
<b>20</b>	2.0	1
<b>22</b>	2.2	1
<b>26</b>	2.6	1
<b>32</b>	3.2	1
<b>38</b>	3.8	1

Performance with GR05 / GR1 pumps  
Displacement 0.9 ÷ 2.2 cc/rev [0.055 ÷ 0.134 in<sup>3</sup>/rev]

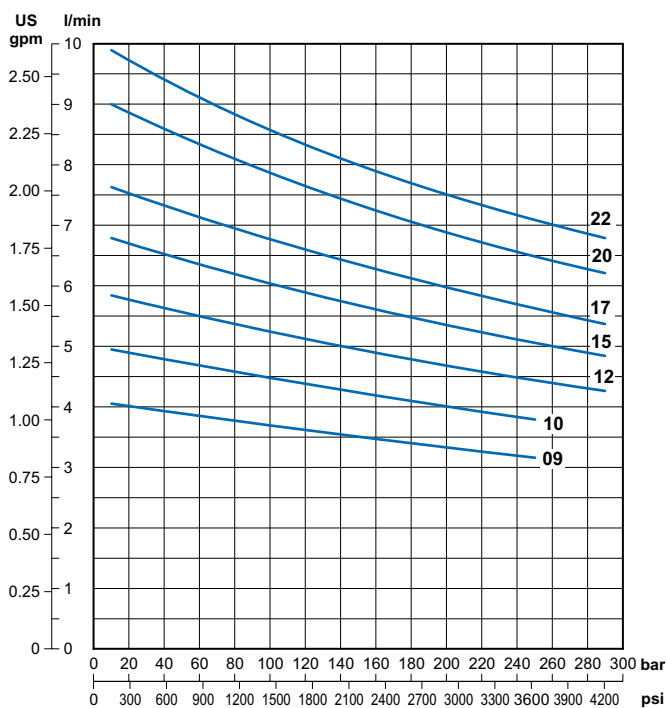

Performance with GR1 pumps  
Displacement 2.6 ÷ 7.8 cc/rev [0.159 ÷ 0.476 in<sup>3</sup>/rev]

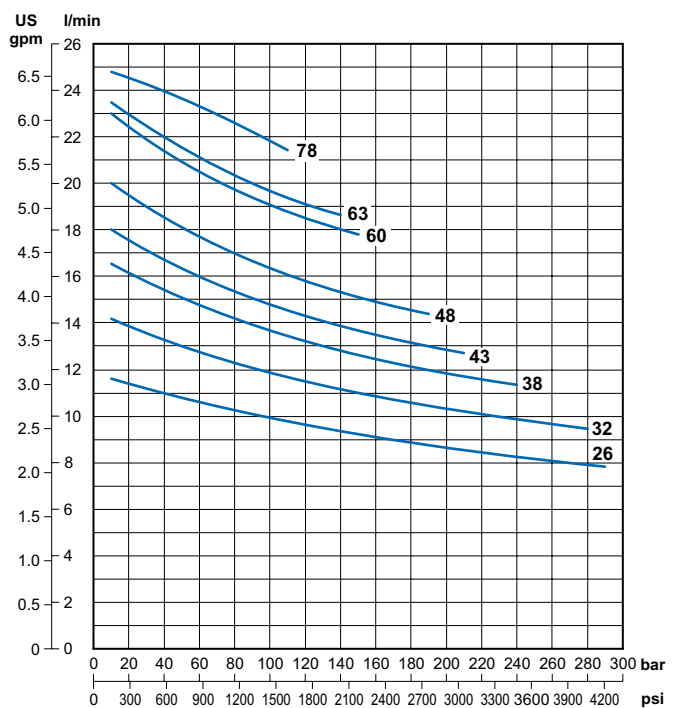

# 25021300 FAN



**Current with GR05 / GR1 pumps**  
Displacement 0.9 ÷ 2.2 cc/rev [0.055 ÷ 0.134 in<sup>3</sup>/rev]

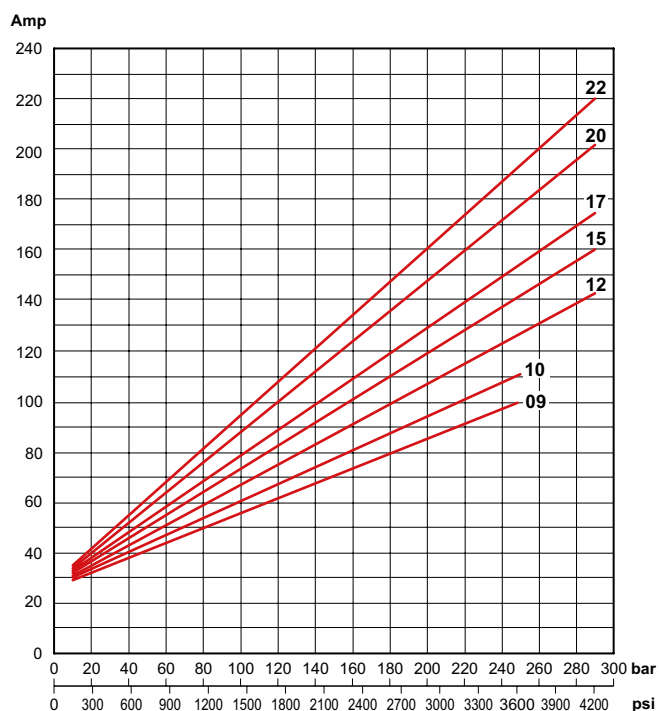

**Current with GR1 pumps**  
Displacement 2.6 ÷ 7.8 cc/rev [0.159 ÷ 0.476 in<sup>3</sup>/rev]

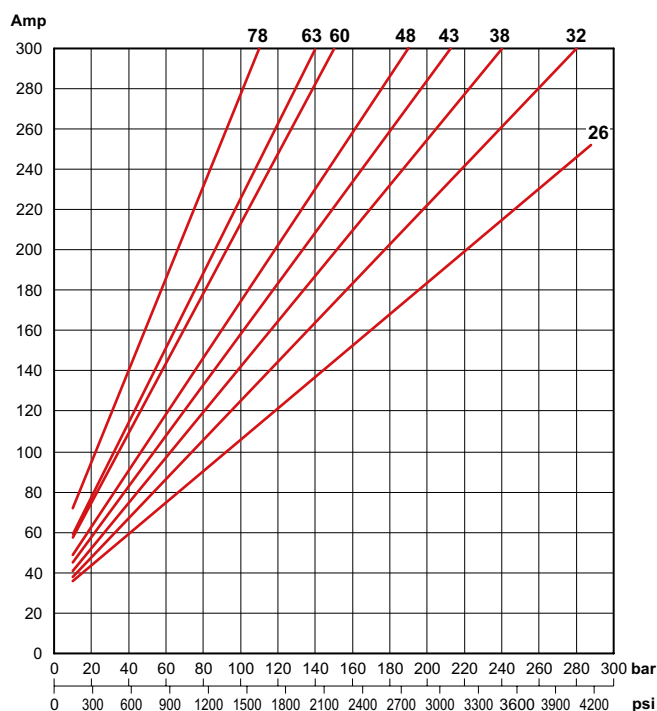

### Thermal characteristics S2 - S3

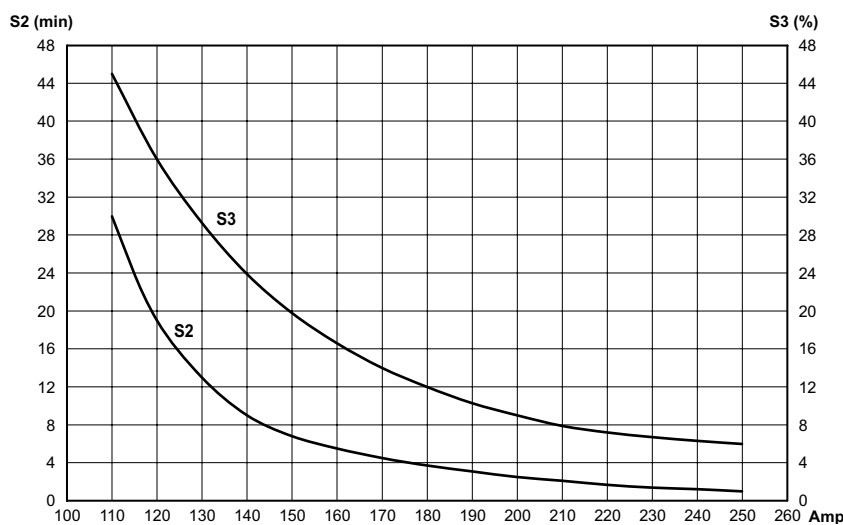

Motor with thermal switch

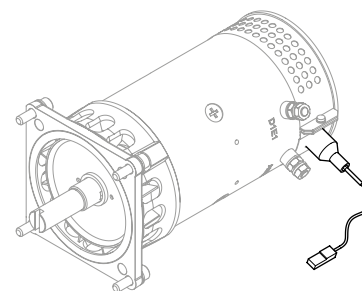

### ORDERING CODE

Power pack	X mm [inch]	Code Fan cooled motor	Code Fan cooled motor with thermal switch	Code Fan cooled kit
FP	53.2 [2.09]	KIT09008.029	*	25017700
MC	43.4 [1.71]	KIT01008.118	KIT01008.119	25006100

Code	Description
KIT07012.019	Starting switch kit 24VDC - 150A (fixing with clamp)

\* please contact our sales department

Reference data: maximum nominal pressure Pmax = 290 bar. Oil ISO VG32 temperature 35°C (viscosity 40 cSt), outside temperature 25°C.

Maximum nominal current Imax = 300A. Stabilized voltage to 24 Vdc detected at the terminals of the electric motor.

## 24 VDC - 3.0 KW - D.125 MOTOR

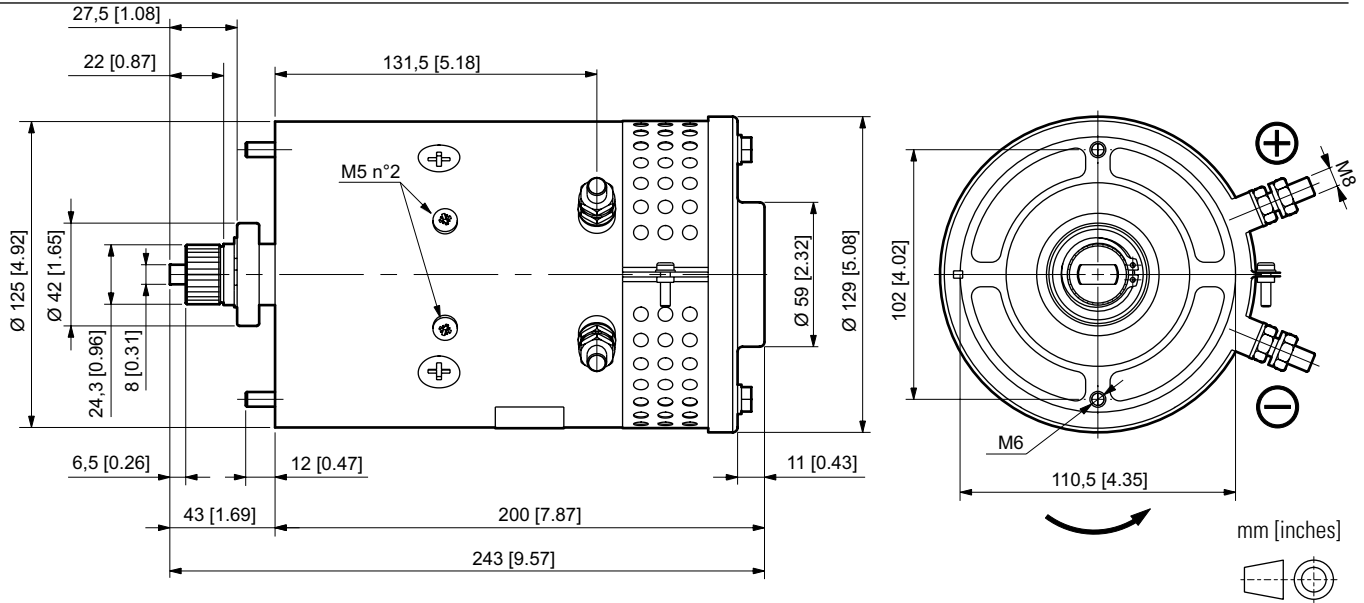

### RATED FEATURES

Voltage	24 VDC
Power	3.0 kW
Nominal diameter	125 mm [4.92 in]
Motor type	Wound field compound
Rotation	CCW
Protection class IP (with motor assembled on hydraulic power pack)	20
S2 / S3 duty service	see curves
Insulation class	F
Weight	10,5 kg [23.15 lb]

### PUMP TYPE

Code	cc/rev.	GR (Size)
09	0.9	05/1
10	1.0	05/1
12	1.2	05/1
15	1.5	1
17	1.7	1
20	2.0	1
22	2.2	1
26	2.6	1
32	3.2	1
38	3.8	1

Code	cc/rev.	GR (Size)
43	4.3	1
48	4.8	1
60	6.0	1
63	6.3	1
78	7.8	1

**Performance with GR05 / GR1 pumps**  
Displacement  $0.9 \div 2.2$  cc/rev [ $0.055 \div 0.134$  in<sup>3</sup>/rev]

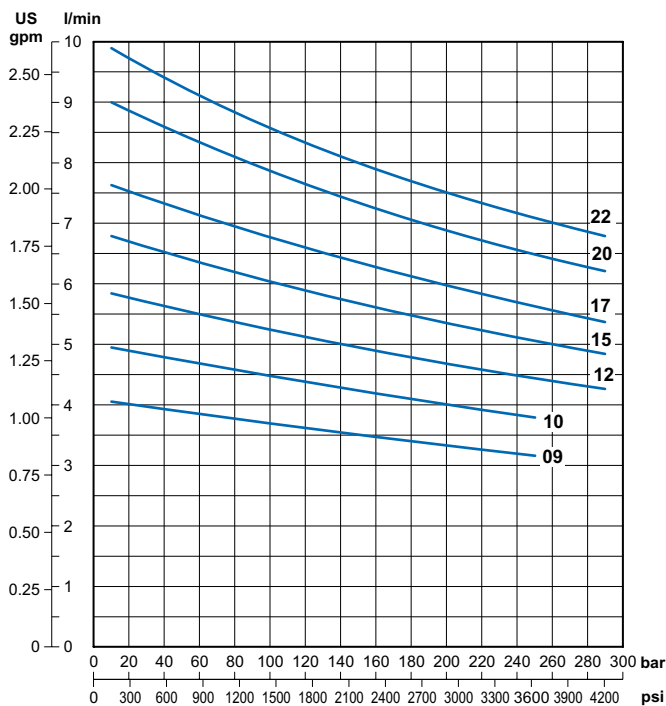

**Performance with GR1 pumps**  
Displacement  $2.6 \div 7.8$  cc/rev [ $0.159 \div 0.476$  in<sup>3</sup>/rev]

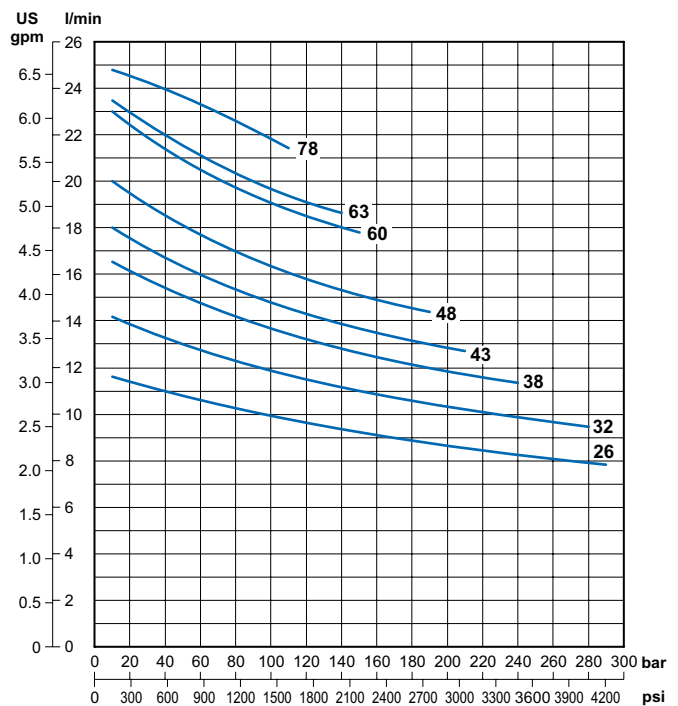

**Current with GR05 / GR1 pumps**  
Displacement  $0.9 \div 2.2 \text{ cc/rev}$  [ $0.055 \div 0.134 \text{ in}^3/\text{rev}$ ]

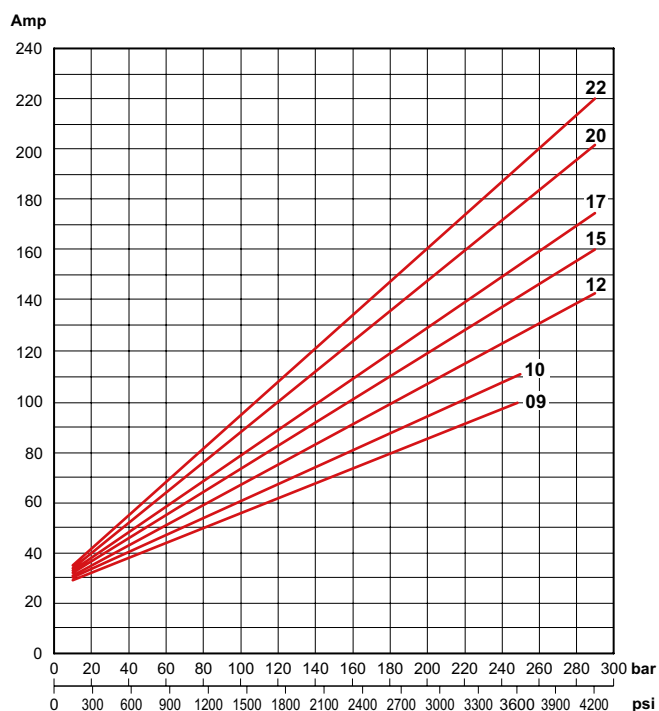

**Current with GR1 pumps**  
Displacement  $2.6 \div 7.8 \text{ cc/rev}$  [ $0.159 \div 0.476 \text{ in}^3/\text{rev}$ ]

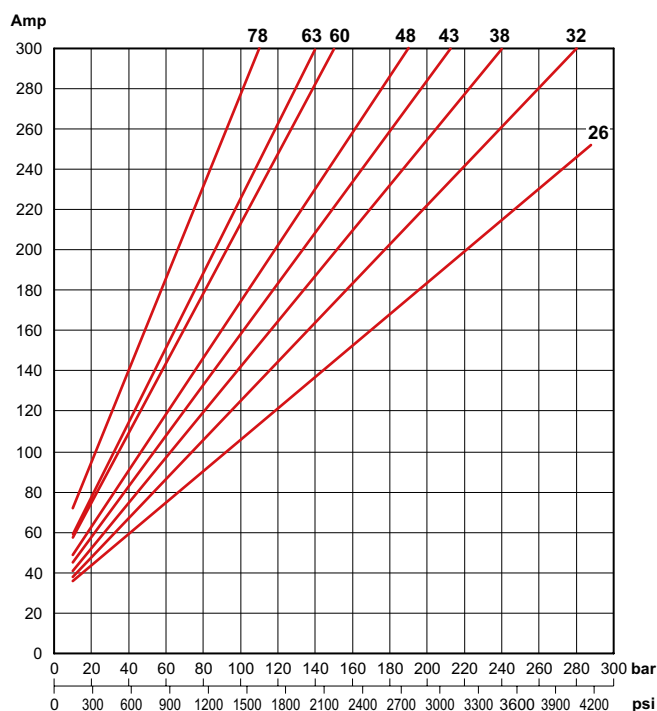

### Thermal characteristics S2 - S3

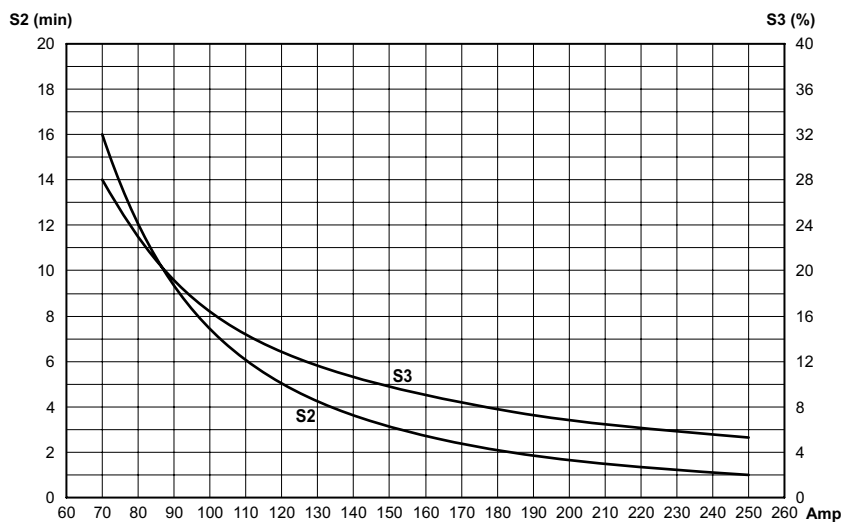

### ORDERING CODE

Code	Description
<b>25022400</b>	24VDC motor - 3.0 kW

Code	Description
<b>KIT07012.019</b>	Starting switch kit 24VDC - 150A (fixing with screws)

Reference data: maximum nominal pressure  $P_{max} = 290 \text{ bar}$ . Oil ISO VG32 temperature  $35^\circ\text{C}$  (viscosity  $40 \text{ cSt}$ ), outside temperature  $25^\circ\text{C}$ .

Maximum nominal current  $I_{max} = 300\text{A}$ . Stabilized voltage to 24 Vdc detected at the terminals of the electric motor.

# 25022400 FAN



## 24 VDC - 3.0 KW - D.125 MOTOR

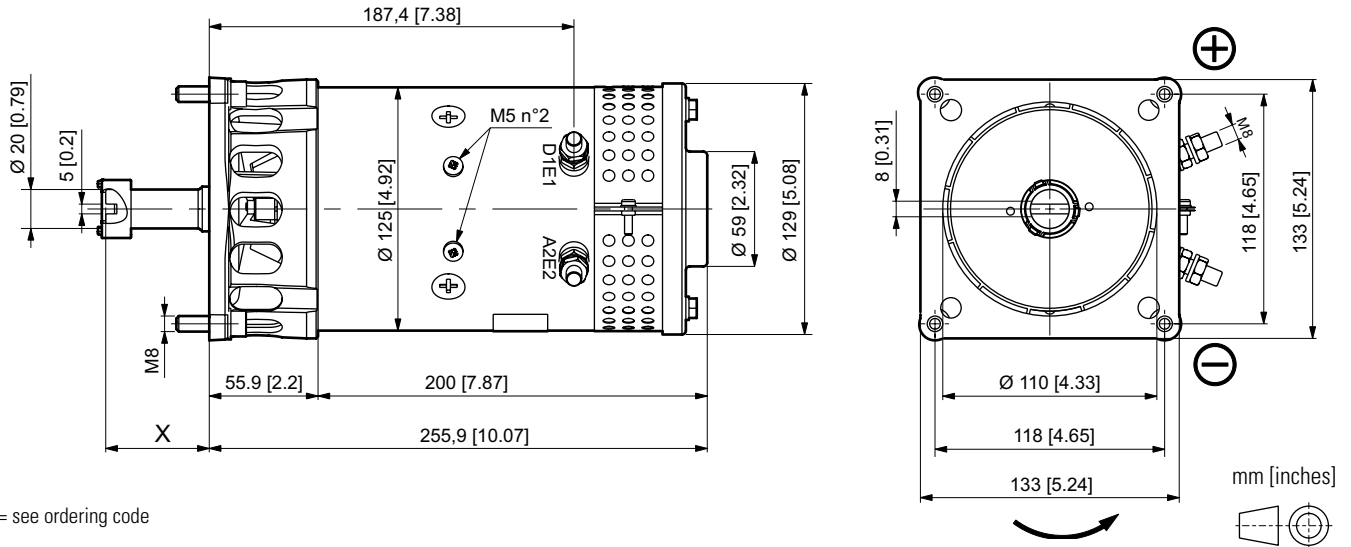

X = see ordering code

### RATED FEATURES

Voltage	24 VDC
Power	3.0 kW
Nominal diameter	125 mm [4.92 in]
Motor type	Wound field compound
Rotation	CCW
Protection class IP (with motor assembled on hydraulic power pack)	20
S2 / S3 duty service	see curves
Insulation class	F
Weight	11.6 kg [25.57 lb]

### PUMP TYPE

Code	cc/rev.	GR (Size)
09	0.9	05/1
10	1.0	05/1
12	1.2	05/1
15	1.5	1
17	1.7	1
20	2.0	1
22	2.2	1
26	2.6	1
32	3.2	1
38	3.8	1

Code	cc/rev.	GR (Size)
43	4.3	1
48	4.8	1
60	6.0	1
63	6.3	1
78	7.8	1

Performance with GR05 / GR1 pumps  
Displacement 0.9 ÷ 2.2 cc/rev [0.055 ÷ 0.134 in<sup>3</sup>/rev]

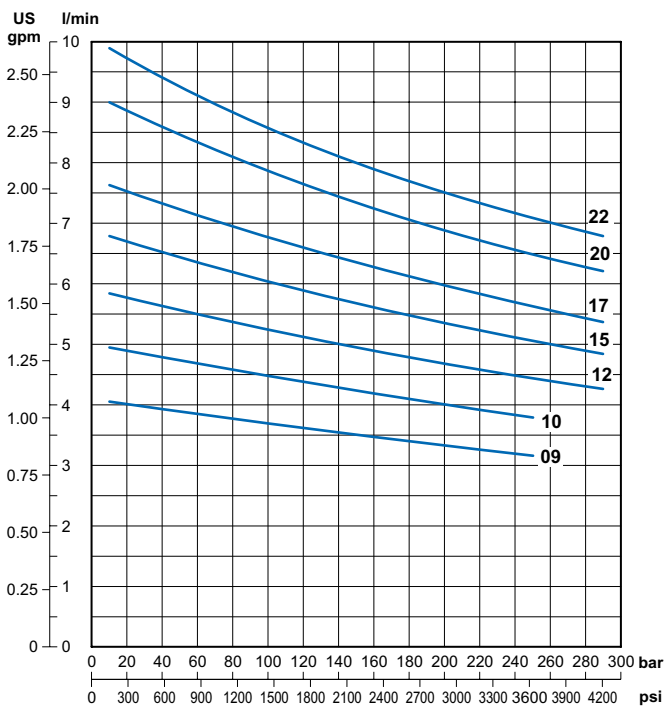

Performance with GR1 pumps  
Displacement 2.6 ÷ 7.8 cc/rev [0.159 ÷ 0.476 in<sup>3</sup>/rev]

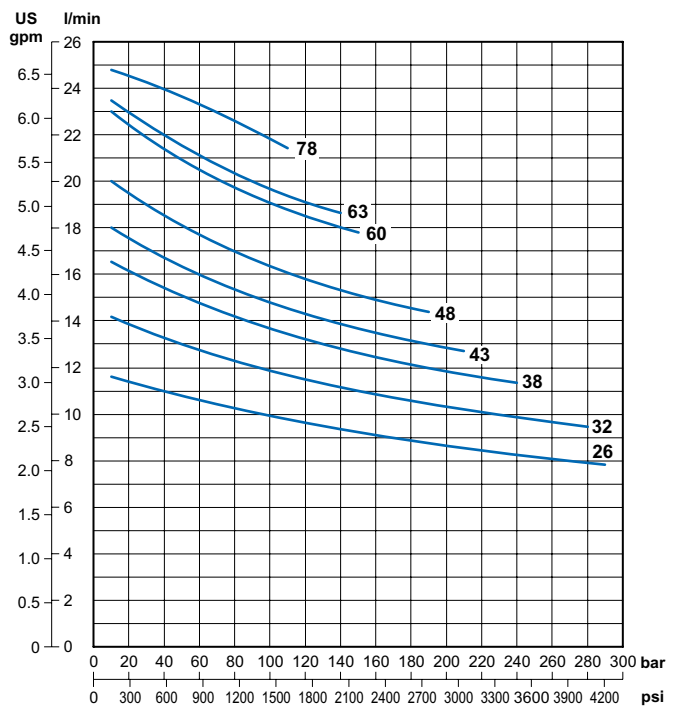

# 25022400 FAN



**Current with GR05 / GR1 pumps**  
Displacement  $0.9 \div 2.2 \text{ cc/rev}$  [ $0.055 \div 0.134 \text{ in}^3/\text{rev}$ ]

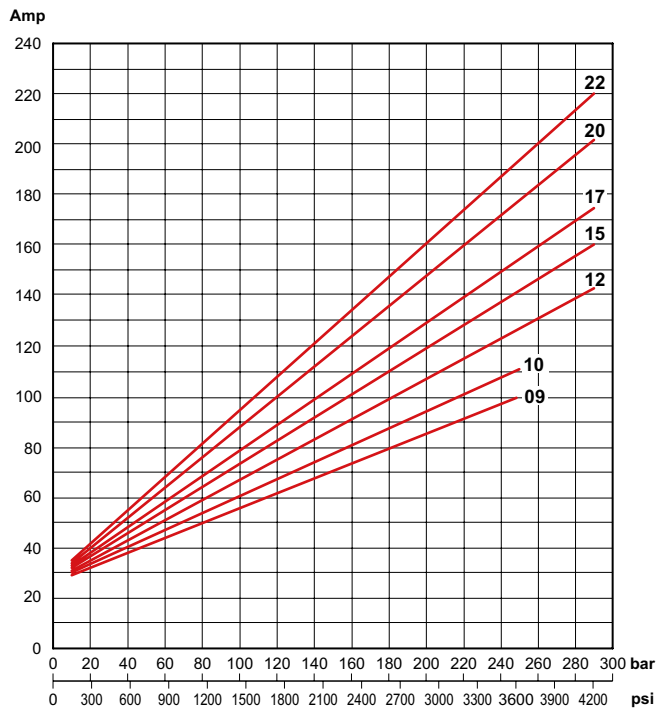

**Current with GR1 pumps**  
Displacement  $2.6 \div 7.8 \text{ cc/rev}$  [ $0.159 \div 0.476 \text{ in}^3/\text{rev}$ ]

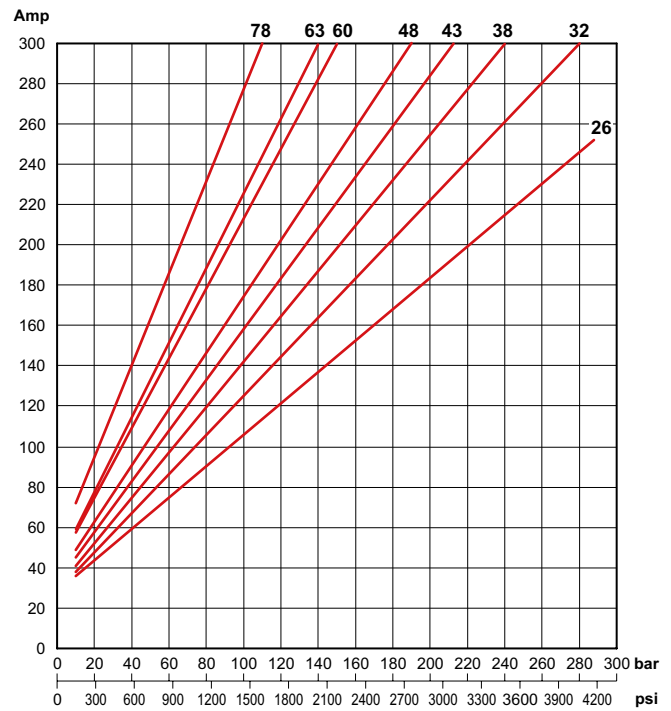

## Thermal characteristics S2 - S3

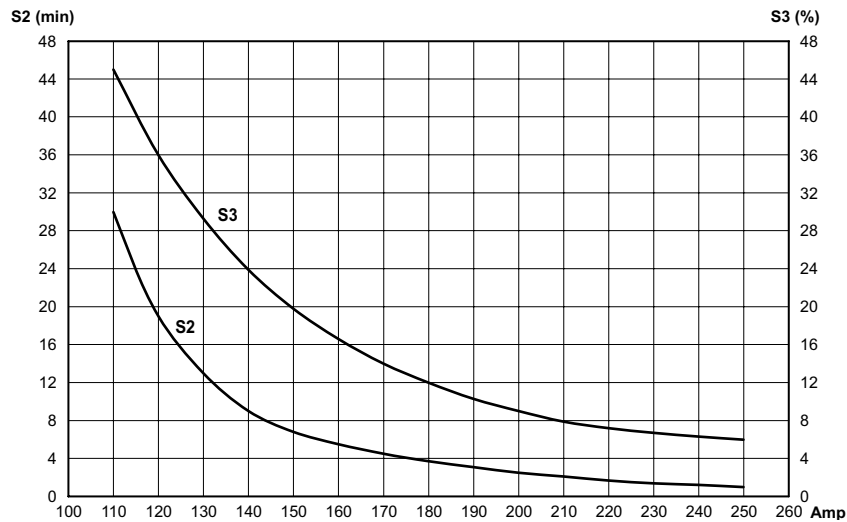

## ORDERING CODE

Power pack	X mm [inch]	Code Fan cooled motor	Code Fan cooled motor with thermal swich	Code Fan cooled kit
FP	53.2 [2.09]	*	*	<b>25017700</b>
MC	43.4 [1.71]	*	*	<b>25006100</b>

Code	Description
<b>KIT07012.019</b>	Starting switch kit 24VDC - 150A (fixing with screws)

\* please contact our sales department

Reference data: maximum nominal pressure  $P_{max} = 290 \text{ bar}$ . Oil ISO VG32 temperature  $35^\circ\text{C}$  (viscosity  $40 \text{ cSt}$ ), outside temperature  $25^\circ\text{C}$ .

Maximum nominal current  $I_{max} = 300\text{A}$ . Stabilized voltage to  $24 \text{ Vdc}$  detected at the terminals of the electric motor.

# Starting switch: 120A

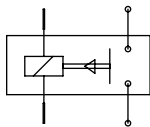
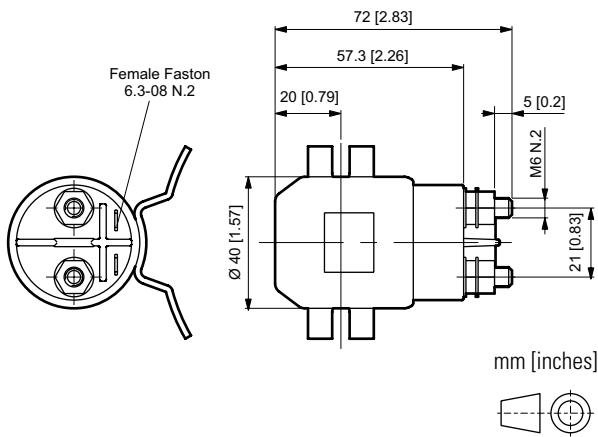

Wiring diagram

## RATED FEATURES

Description	12 VDC	24 VDC
Min cut-on voltage	8.4 V @ 20°C 11 V @ 60°C	16.8 V @ 20°C 23 V @ 60°C
Rated voltage	12 VDC	24 VDC
Cut off voltage	0.6 ÷ 4 VDC	1.2 ÷ 8 VDC
Current consumption	1.9 ± 0.2 A	0.8 ± 0.1 A
Operating temperature range	-20 ÷ +60 °C	-20 ÷ +60 °C
Vibration specification	9 g	9 g
Rated Current	120 A	120 A
Coil short time duty	S2 = 15 min	S2 = 20 min
Protection degree	IP 67	IP 67
Weight	290 gr [0.69 lb]	320 gr [0.71 lb]

## ORDERING CODE

Motor type	Code (12 VDC)	Code (24 VDC)
D. 80 fixing with clamp	<b>KIT07012.027</b>	<b>KIT07012.032</b>
D. 115 fixing with clamp	<b>KIT07012.033</b>	<b>KIT07012.034</b>
D. 115 fixing with screws	<b>KIT07012.025</b>	<b>KIT07012.026</b>

# Starting switch: 150A

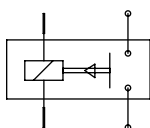
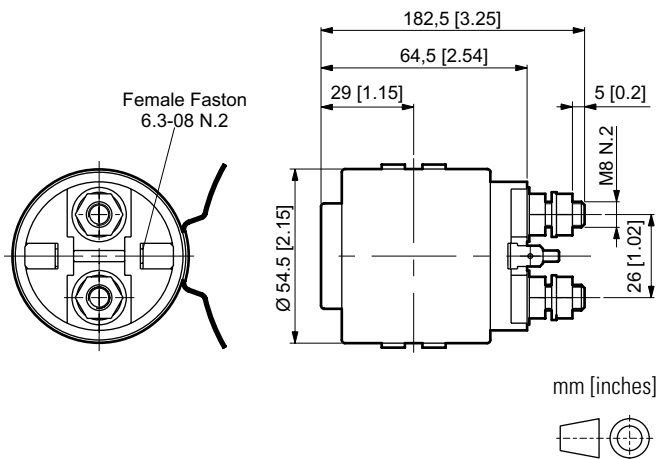

Wiring diagram

## RATED FEATURES

Description	24 VDC
Min cut-on voltage	16.8 V @ 20°C 23 V @ 60°C
Rated voltage	24 VDC
Cut off voltage	1.2 ÷ 8 VDC
Current consumption	1.1 ± 0.1 A
Operating temperature range	-30 ÷ +60 °C
Vibration specification	9 g
Rated Current	150 A
Coil short time duty	S3= 10% @ 350A
Protection degree	IP 54
Weight	690 gr [1.52 lb]

## ORDERING CODE

Motor type	Code (24 VDC)
D. 125 fixing with screws	<b>KIT07012.019</b>





**BREVINI<sup>®</sup>**

*Motion Systems*



OIL SOLUTIONS

1800-OILSOL  
1800-645765

<https://oilsolutions.com.au/>

[sales@oilsolutions.com.au](mailto:sales@oilsolutions.com.au)

Code DOC00053 - Rev. 08

**Dana Motion Systems Italia S.r.l.**

Fluid Power Division

Sede operativa: Via Giulio Natta 1, 42124 Reggio Emilia - Italy  
Tel: +39.0522.270711 - Fax: +39.0522.505856

Sede legale: Via Luciano Brevini 1/A, 42124 Reggio Emilia - Italy  
Tel: +39.0522.9281 - Fax: +39.0522.928300

[www.dana.com/brevini](http://www.dana.com/brevini) - [dana.re@dana.com](mailto:dana.re@dana.com)

