

5 Monobloc directional control valves HDM18



OIL SOLUTIONS

PO Box 38
Strathfieldsaye, VIC, 3551
1800 OIL SOL
1800 645 765
sales@oilsolutions.com.au
www.oilsolutions.com.au
"For All Your Hydraulic Needs"



Contents

5.1	General specifications	53
5.2	Dimensional data	54
5.3	Performances curves	55
5.4	Monobloc bodies	56
5.5	Adjustable direct acting Relief Valve RV	58
5.6	Spool charts	58
5.7	Spool positioners	59
5.8	Lever styles	60
5.9	Hydraulic-Pneumatic control ON-OFF	62
5.10	Pneumatic controls	62
5.11	Hydraulic Proportional control	62
5.12	Electro-Hydraulic controls	63
5.13	Solenoids for pilot electrovalves EHI-EHE	65
5.14	Electromagnetic controls ON-OFF	66

5.1 General specifications

Technical specification		
Max flow rate	l/min. U.S.G.P.M.	70 18
Max continuous operating pressure supply port P	bar PSI	350 5000
Max intermittent peak pressure Work port A/B	bar PSI	400 5800
Max back pressure tank port T	bar PSI	30 430
Oil temperature	° C ° F	-10 to 80 14 to 180
Oil viscosity	mm ² /s	16 to 75
Oil filtration	μ	≤30

Spool leakage at 100 bar (1450 PSI), Temp. 50° C (120° F), viscosity 27 mm ² /s:		
Maximum	cm ³ /min. Cu. In./min.	14 0.854
Average	cm ³ /min. Cu. In./min.	7 0.427
Lower values on demand (to be agreed with our Sales Dept.)		

Number of spools *	1 to 2
Adjustable direct operated relief valve (tamper-proof seal available on request)	RV
Load hold check valve in each section	LC

5.1.1 Weight

Version	kg	lb
HDM18/1	4.3	9.60
HDM18/2	6.0	13.2

* For HDM18/3 and HDM18/4 please contact our Sales Department.

5.1.2 Material specification:

Body: High strength cast-iron.
Spool: Hardened steel and chrome plated
Seals: Buna "N".

5.1.3 Standard features:

- 1) Parallel circuit
- 2) Balanced interchangeable spools (provides minimum leakage, smooth operation)
- 3) Wide selection inlets, work ports, and outlets threaded ports.
- 4) Negative overlapping of the spool.

5.1.4 Optional features available:

- 1) Open or closed centre positions, 3 or 4 way operations, 3 or 4 position (float position), full open centre (motor spool) and other spool options.
- 2) Carry over.
- 3) Series circuit
- 4) Complete lever assembly
- 5) Wide range of positioners

5.1.5 Symbols:

P: inlet port
T: outlet port
A/B: work ports
H.P.C.O.: carry-over
RV: relief valve
P₁T₁: side inlet and outlet ports
 3.1.0.2: spool position
P: pressure line
T: exhaust line
E: centre line (by pass).

5.2 Dimensional data

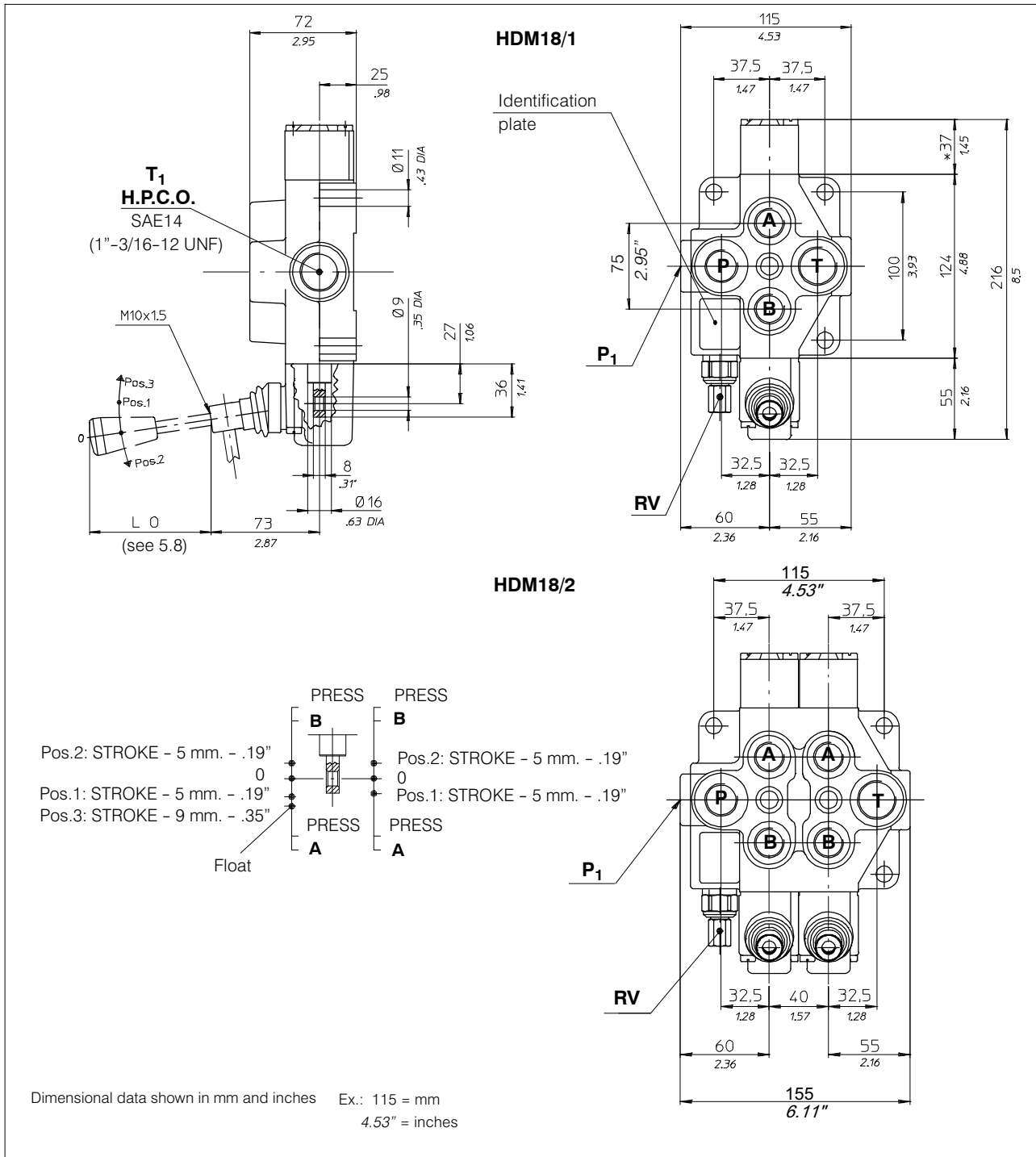

5.3 Performance curves

Oil: Shell Tellus T37
 Temperature: 50° C (120° F)
 Viscosity: 27 mm²/s

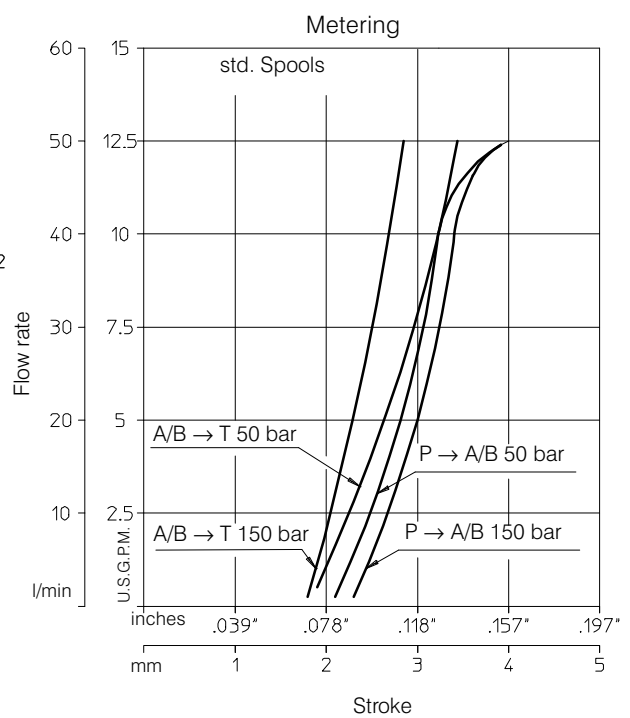
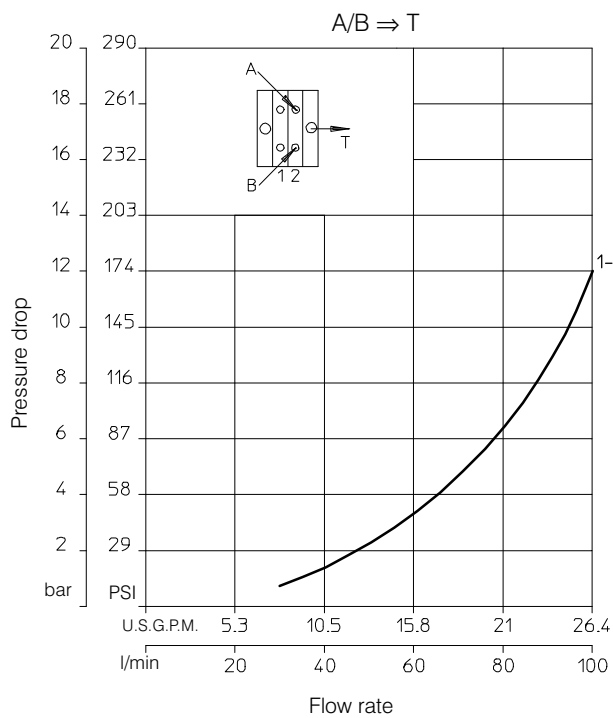
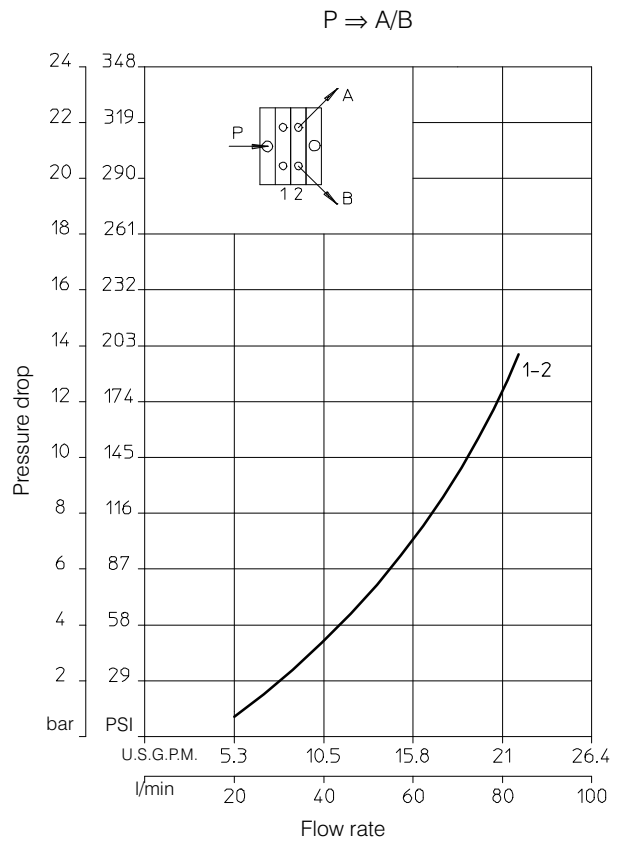
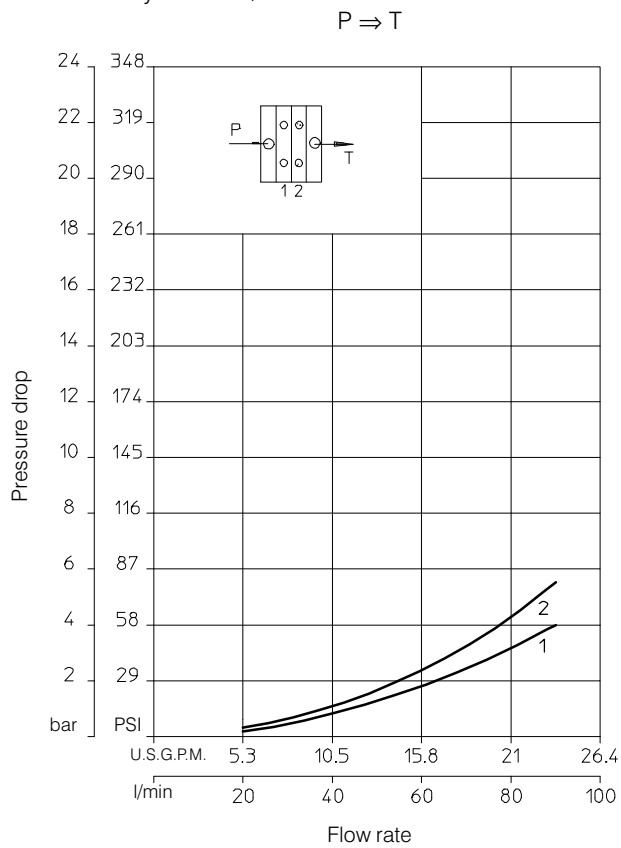

5.4 Monobloc bodies

5.4.1 Standard circuits: parallel Open centre with P - T - RV

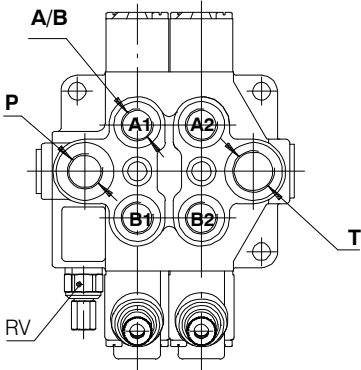

P	A/B	T	Type/Code	
			HDM18/1	HDM18/2
M18X1.5	M18X1.5	M18X1.5	K01 200.9441.1001.0	K01 200.9442.1001.0
M18X1.5	M18X1.5	M22X1.5	K03 200.9441.1002.0	K03 200.9442.1002.0
1/2" BSP	1/2" BSP	1/2" BSP	K02 200.9441.3006.0	K02 200.9442.3004.0
1/2" BSP	1/2" BSP	3/4" BSP	K05 200.9441.3007.0	K05 200.9442.3005.0
SAE10	SAE10	SAE10	K04 200.9441.8004.0	K04 200.9442.8003.0
SAE10	SAE10	SAE12	K06 200.9441.8005.0	K06 200.9442.8004.0

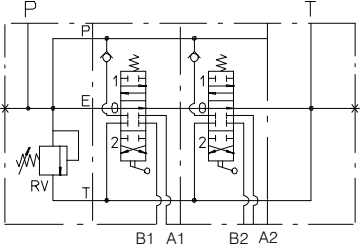

5.4.2 Standard circuits: parallel Open centre and carry-over with P - T - RV H.P.C.O

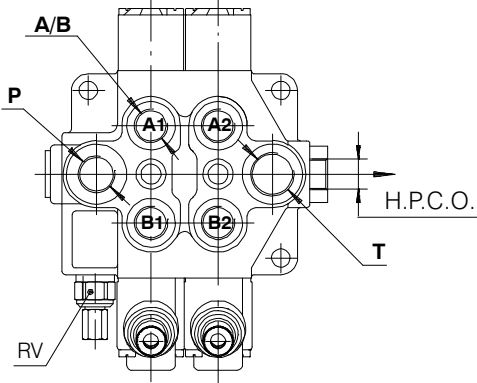

P	A/B	T - HPCO	Code	
			HDM18/1	HDM18/2
M18X1.5	M18X1.5	M18X1.5	K21 200.9441.1003.0	K21 200.9442.1003.0
M18X1.5	M18X1.5	M22X1.5	K23 200.9441.1004.0	K23 200.9442.1004.0
1/2" BSP	1/2" BSP	1/2" BSP	K22 200.9441.3008.0	K22 200.9442.3006.0
1/2" BSP	1/2" BSP	3/4" BSP	K25 200.9441.3009.0	K25 200.9442.3007.0
SAE10	SAE10	SAE10	K24 200.9441.8006.0	K24 200.9442.8005.0
SAE10	SAE10	SAE12	K26 200.9441.8007.0	K26 200.9442.8006.0

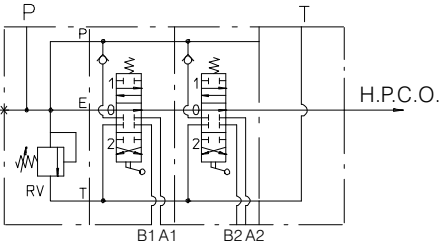

Note: Body codes consist of: machined casting, seals, plugs and check valve only. Not to be used for complete valve order.

5.4.3 Optional circuits: series and tandem Open centre with P - T - RV

P	A/B	T	Type/Code	
			HDM18/1	HDM18/2
M18X1.5	M18X1.5	M18X1.5	K31	K31
M18X1.5	M18X1.5	M22X1.5	K33	K33
1/2" BSP	1/2" BSP	1/2" BSP	K32	K32
1/2" BSP	1/2" BSP	3/4" BSP	K35	K35 200.9442.3008.0
SAE10	SAE10	SAE10	K34	K34
SAE10	SAE10	SAE12	K36	K36

Note: Body codes consist of: machined casting, seals, plugs and check valve only. Not to be used for complete valve order.
For availability of -K- bodies without code please contact our Sales Department.

5.5 Adjustable direct acting Relief Valve RV

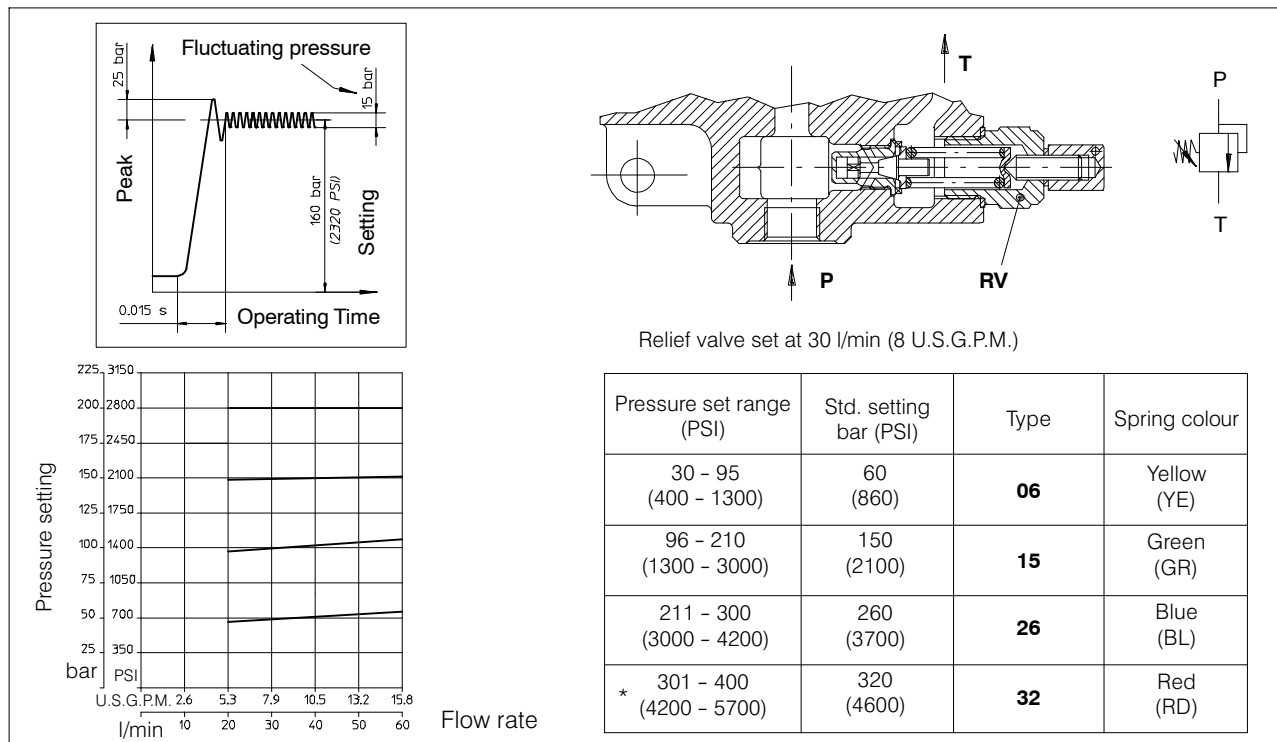

* The maximum operating pressure for each valve series is indicated in the "Technical specification" at the first page of each valve section.

5.6 Spool charts

Spool scheme	Spool features	Type
	4 way - 3 position A/B closed E open by pass	A AS*
	4 way - 3 position A/B-E closed	B
	4 way - 3 position A/B to tank in neutral E open by pass	C CS*
	4 way - 3 position A closed B to tank in neutral	D
	3 way - 3 position B closed E open by pass	G GS*
	4 way - 3 position B closed A to tank in neutral	L

	4 way - 3 position with differential spool in 2 nd position	R**
	3 way - 3 position A closed E open by pass	S SS*
	4 way - 3 position series connection	X XS*
	4 way - 3 position A/B to tank in neutral series connection	XC
	4 way - 4 position 4 th float position	Z ZS*
** : special body required		
* : High metering spool (max. flow suggested 40 l/min)		

5.7 Spool positioners

Spool position				Stroke mm	Type	Code
3	1	0	2			
	○	*	○	5	08	200.9686.1008.0
	●	●	○	5	10	200.9686.3004.0
	●	●	●	5	17	200.9686.2014.0
	○	●	●	5	20	200.9686.3009.0
		●	●	5	25	200.9686.2015.0
	*		○	10	27	200.9686.1044.0
		*	○	5	29	200.9686.3025.0
	○	*	○	5	30	200.9686.1048.0
	○	*	○	5	32	200.9686.1061.0
	○	*	○	5	34	200.9686.1065.0
	●		●	10	36	200.9686.2017.0
	○		*	10	37	200.9686.1066.0
	○	*		5	38	200.9686.1069.0
	○	*	○	5	79	200.9686.1091.0
	○	*	○	5	84	200.9686.1098.0
	○	*	○	5	133	200.9686.1031.0
●	○	*	○	4- 5- 5	136	200.9686.4012.0

- * Initial hand lever position
- Hand lever in detent position
- Spring return position of hand lever

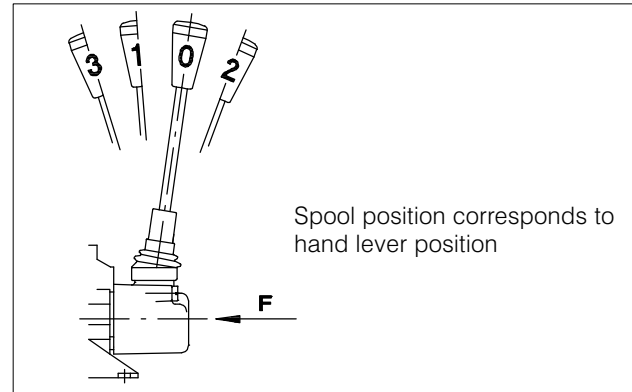

F (N) = Force in Newton (N) needed to operate the spool

F (N)	Spool position control
260	08
130	79
190	133 (standard)

Note: consult factory for different configurations.

5.7.1 Spool positioners dimensions

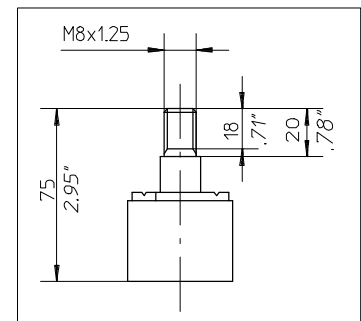
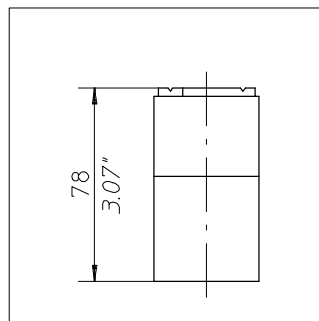
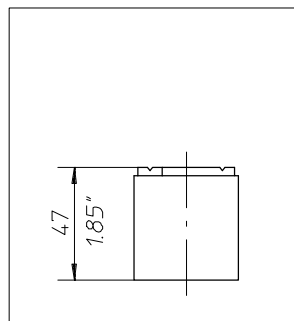
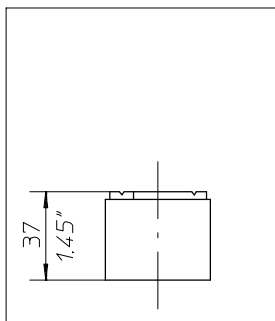

Spool positioners 08 - 38 - 79 - 133	Spool positioners 10 - 17 - 20 - 25 - 27 29 - 36 - 37	Spool positioner (Z spool type) 136	Spool positioner 84
--	---	--	-------------------------------

5.7.2 Microswitch control

Type 30	Microswitch is operated when the spool is in pos. 1		<p>The microswitch is supplied only on customer's request.</p>
Type 32	Microswitch is operated when the spool is in pos. 2		
Type 34	Microswitch is operated when the spool is in pos. 1 and 2		

5.8 Lever styles

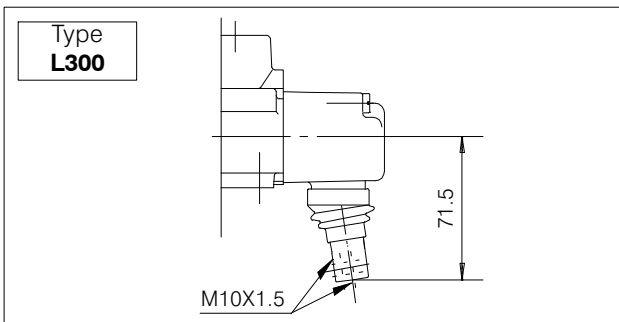
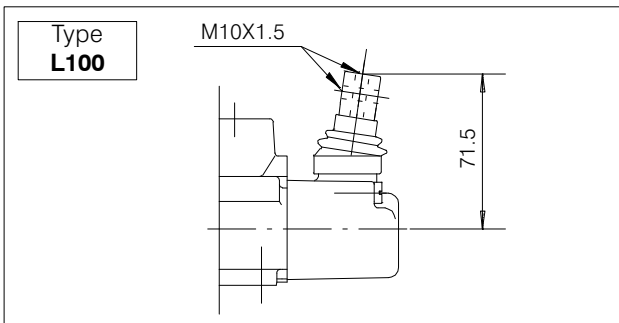
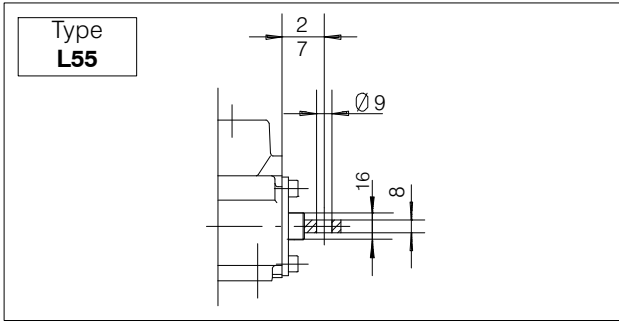

Technical drawing of lever style L51 showing dimension L_o .

L_o		Type	Code
mm	inches		
185	7.28	AL001	200.7022.2001.0
250	9.84	AL002	200.7022.2003.0
300	11.81	AL003	200.7022.2004.0
350	13.78	AL004	200.7022.2005.0

5.8.1 Safety levers

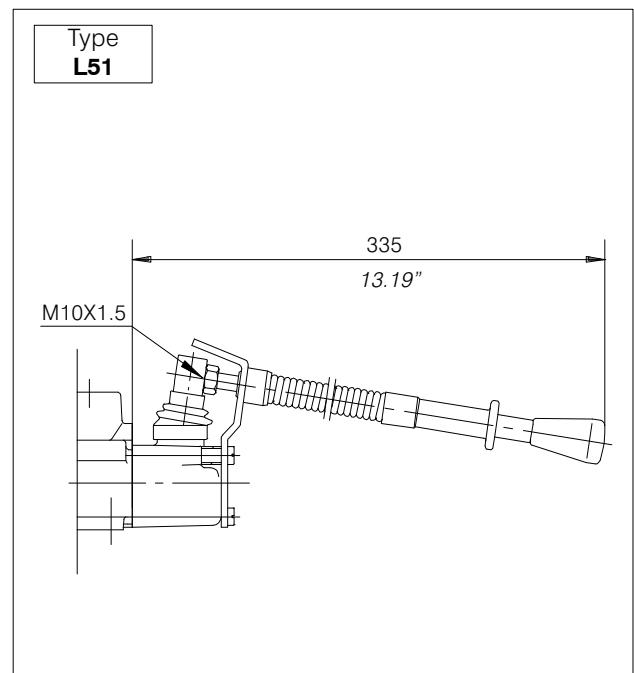
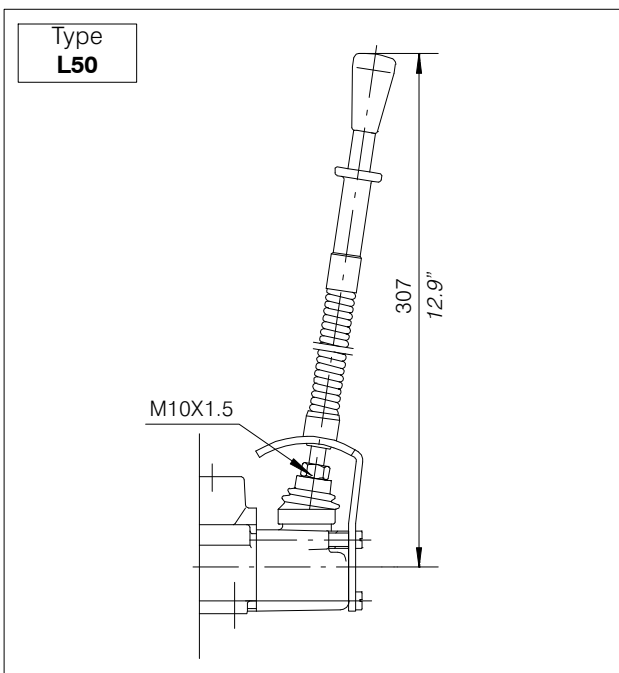

5.8.2 Remote cable control

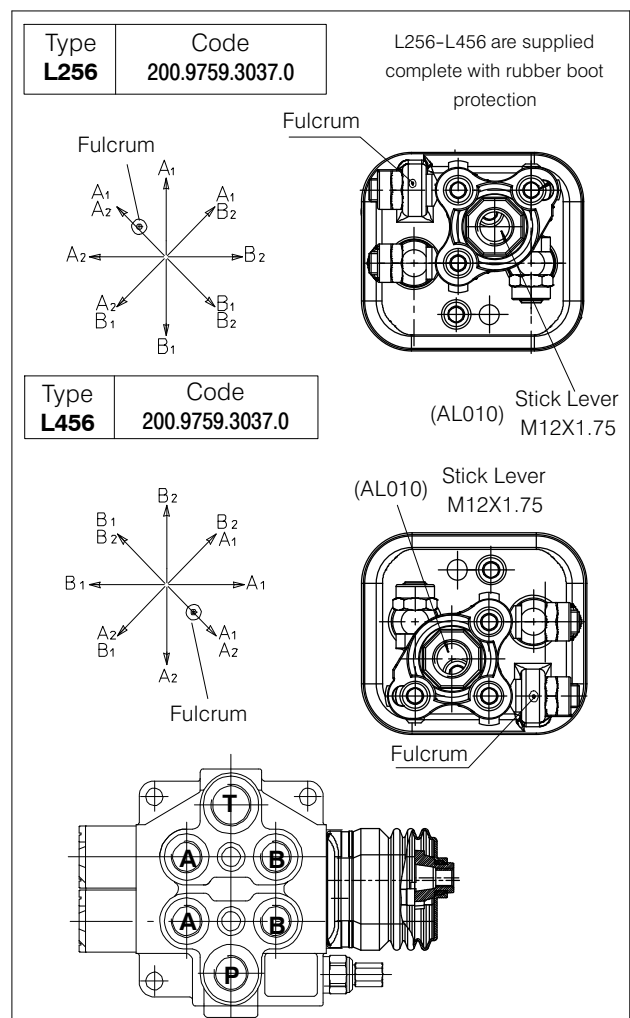
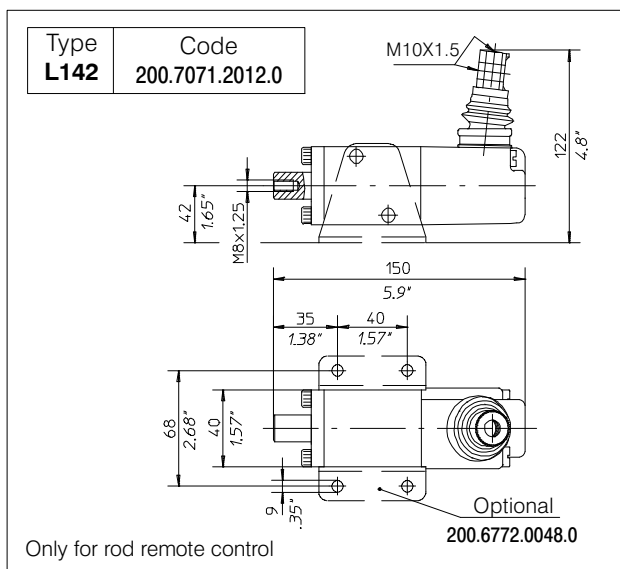
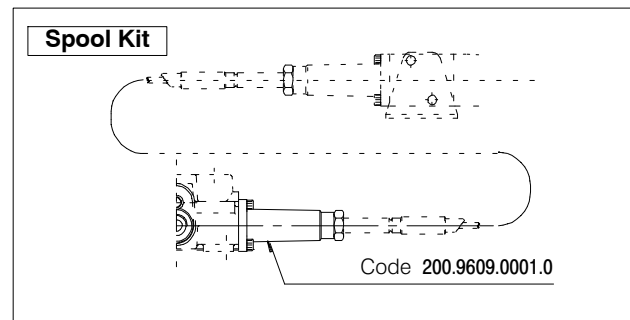
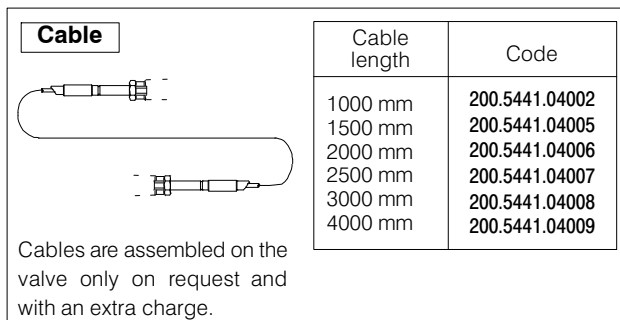
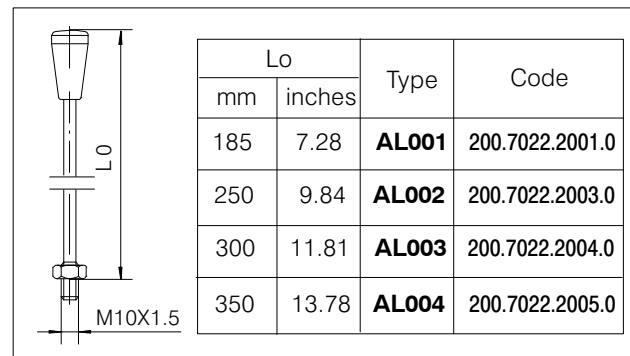
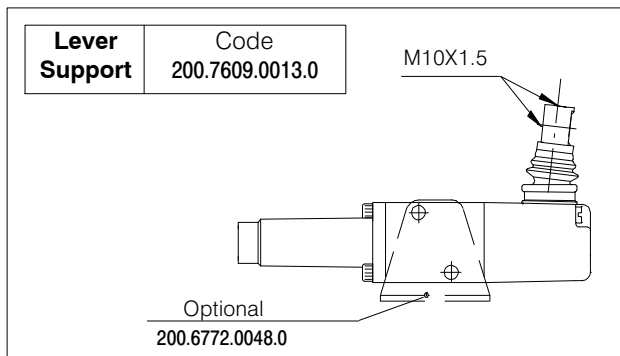

5.8.3 Cross joystick for dual axis spool control

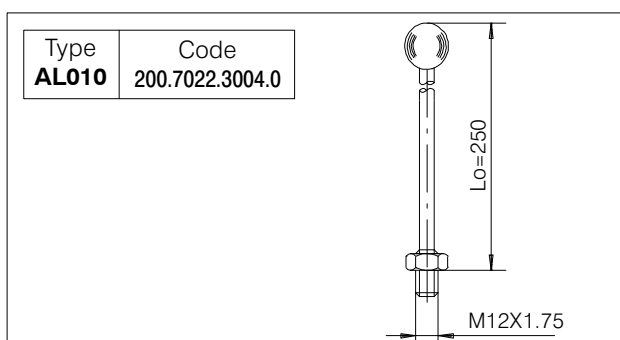

5.9 Hydraulic-Pneumatic control ON-OFF

Type	Code
HP 24	200.9686.5011.0

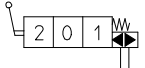

Operating conditions

Hydraulic:

Pressure range: (bar) Min. 6 - Max. 15
(PSI) Min. 85 - Max. 215

Pneumatic:

Pressure range: (bar) Min. 6 - Max. 10
(PSI) Min. 85 - Max. 145

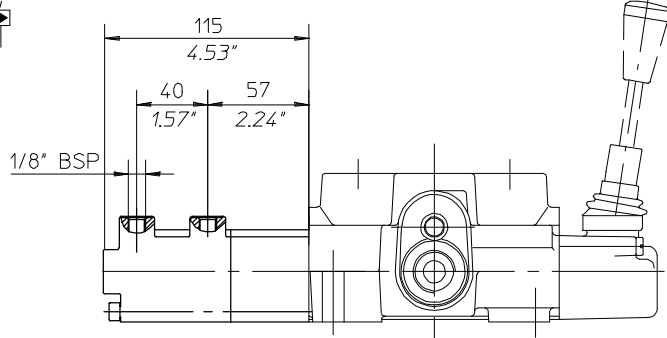

5.10 Pneumatic controls

5.10.1 Pneumatic proportional control

Type	Code
PP 150	200.9686.5009.0

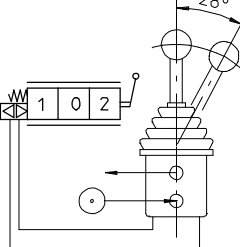
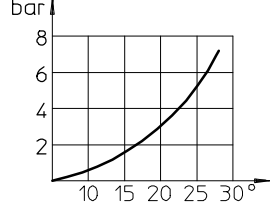
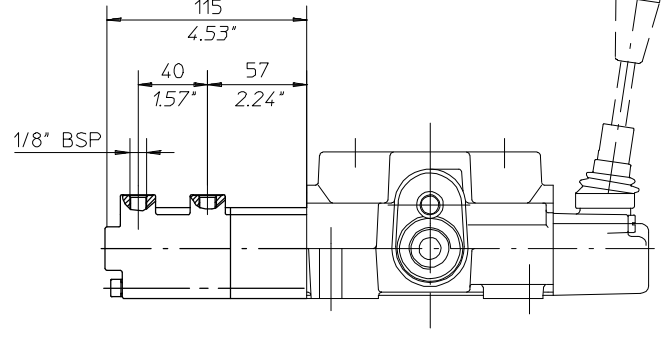

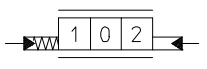

5.11 Hydraulic Proportional control

Type	Code
HP 50	200.9686.5019.0

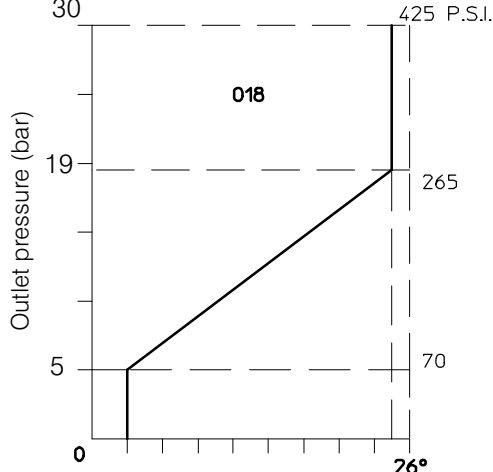

Joystick adjustment diagram



Adjustment range: (bar) Min. 5 - Max. 30
(PSI) Min. 70 - Max. 420

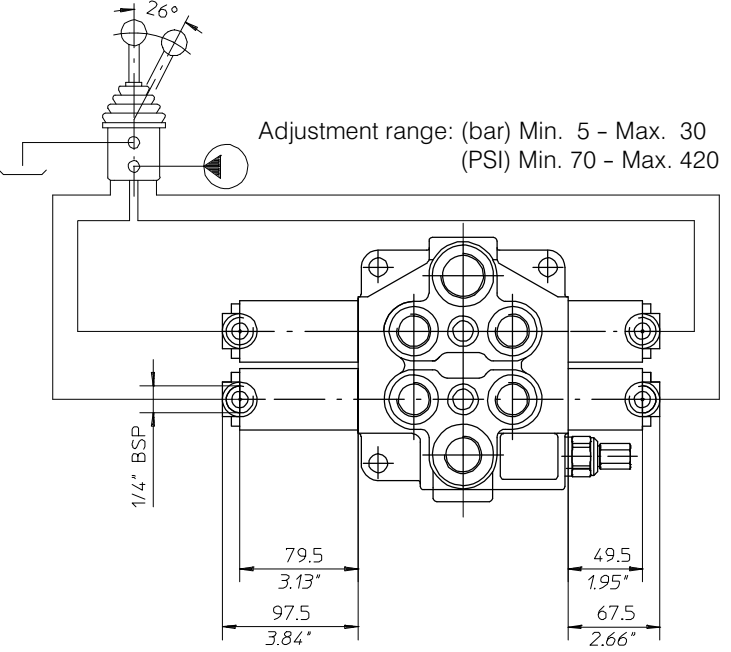

5.12 Electro-Hydraulic controls

5.12.1 Electro-hydraulic control internal pilot version ON-OFF with pressure reducing valve

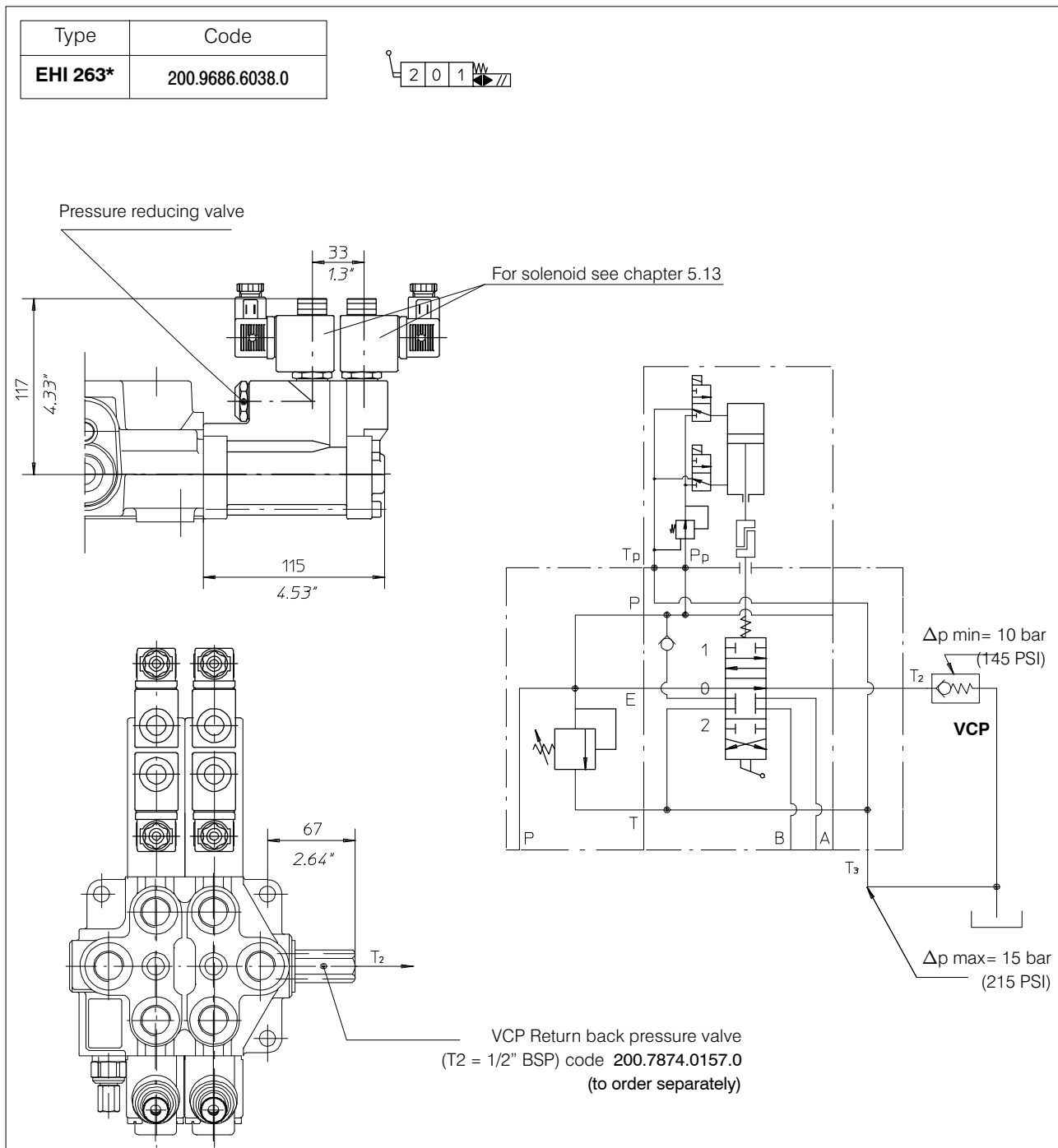

Mechanical and hydraulic features

Max pressure on P_p port 300 bar (4200 PSI)
 Reduced pressure after
 pressure reducing valve 10 bar (145 PSI)
 Fixed delivery on P_p
 pilot line 1 l/min (0.26 U.S.G.P.M)

Leakage of pressure reducing
 valve (in neutral pos.) 100 ml/min (6.1 in³/min)
 Min. suggested filtration 25 micron
 Operating oil temperature min. -30°C- max. 90°C
 min. -22°F - max 194°F

* EHI 263: special body required.

5.12.2 Electro-hydraulic controls external pilot version ON-OFF

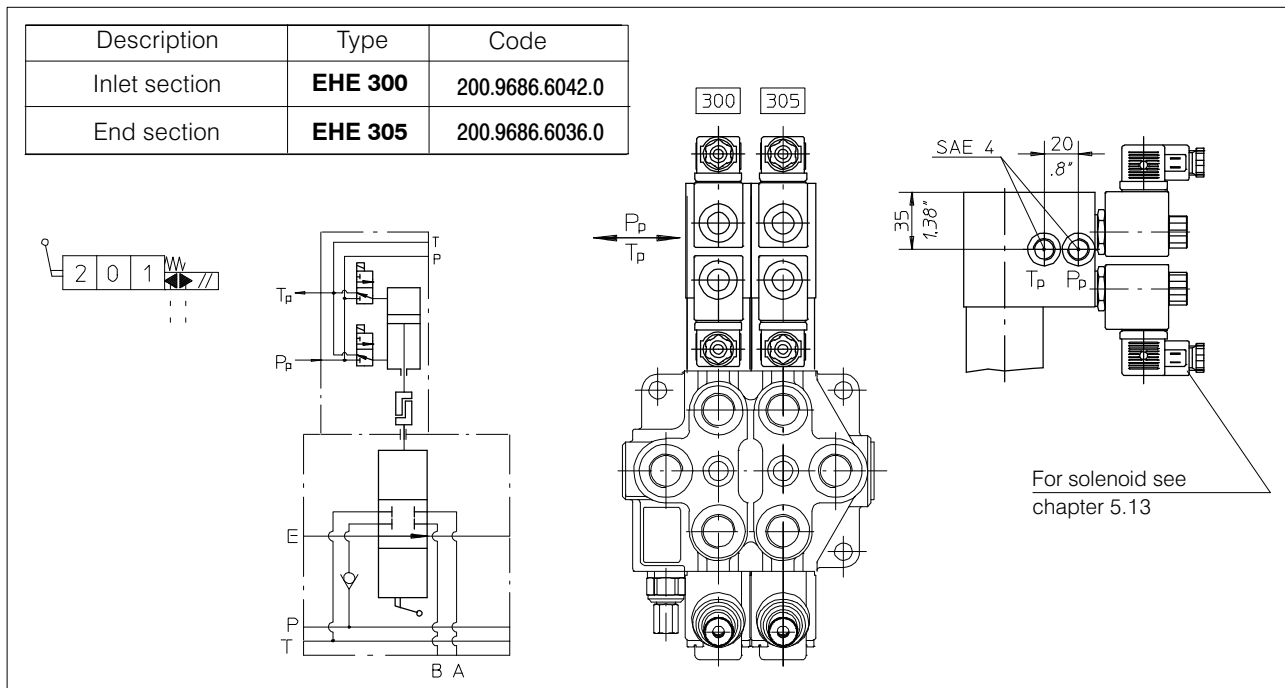

5.12.3 Electro-hydraulic control external pilot version ON-OFF with pressure reducing valve on inlet manifold

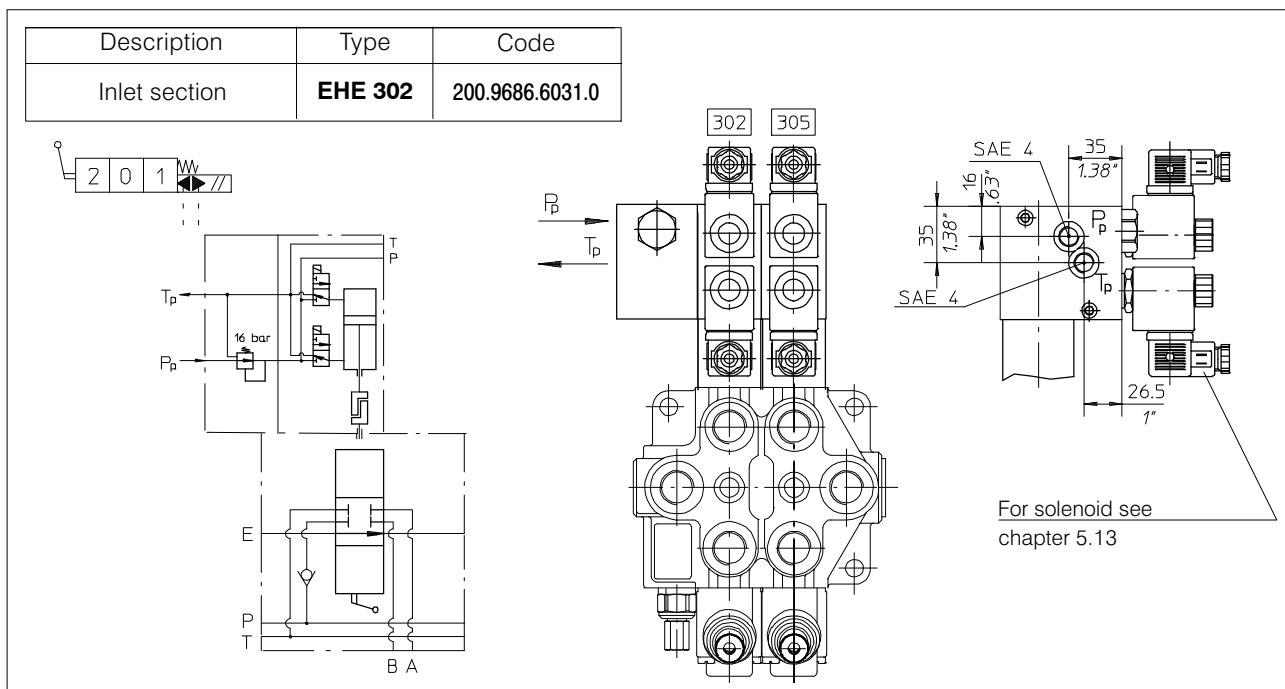

Mechanical and hydraulic features

Pilot pressure min. 10 bar (140 PSI)
 Pilot pressure max. 30 bar (420 PSI)
 Pilot pressure with pressure reducing valve 12 bar (175 PSI)
 Pilot flow to each working section 1 l/min (0.26 U.S.G.P.M.)

Operating oil temperature min. -30°C - max. 90°C
 min. -22°F - max. 194°F
 Leakage of pressure reducing valve (in neutral pos.) 100 ml/min (6.1 in³/min)
 Min. suggested filtration 25 micron

5.13 Solenoids for pilot electrovalves EHI-EHE

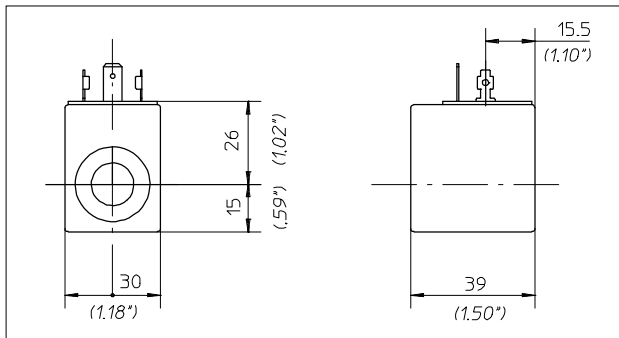

Wire class	F (VDE 0580)
Coil insulation	IP65 (DIN 40050)
Duty rating	ED 100%
Stabilized temperature	70 °C
Voltage tolerance	± 10%

Supply Voltage	Nominal coil voltage	Power (Watt)	Resistance (Ohm)		Current (Ampere)		Coil code
			Ambient temperature	Stabilized temperature	Ambient temperature	Stabilized temperature	
12 V. DC	12 V. DC	18.7	7.7	10.8	1.56	1.11	200.6749.1003.0
24 V. DC	24 V. DC	18.6	31	41.4	0.77	0.58	200.6749.2003.0
24 V. AC	21.6 V. DC	17.3	27	36	0.80	0.60	200.6748.2003.0
110 V. AC	98 V. DC	15.6	630	825	0.157	0.120	200.6748.4003.0
220 V. AC	198 V. DC	15.7	2500	3300	0.08	0.06	200.6748.6003.0

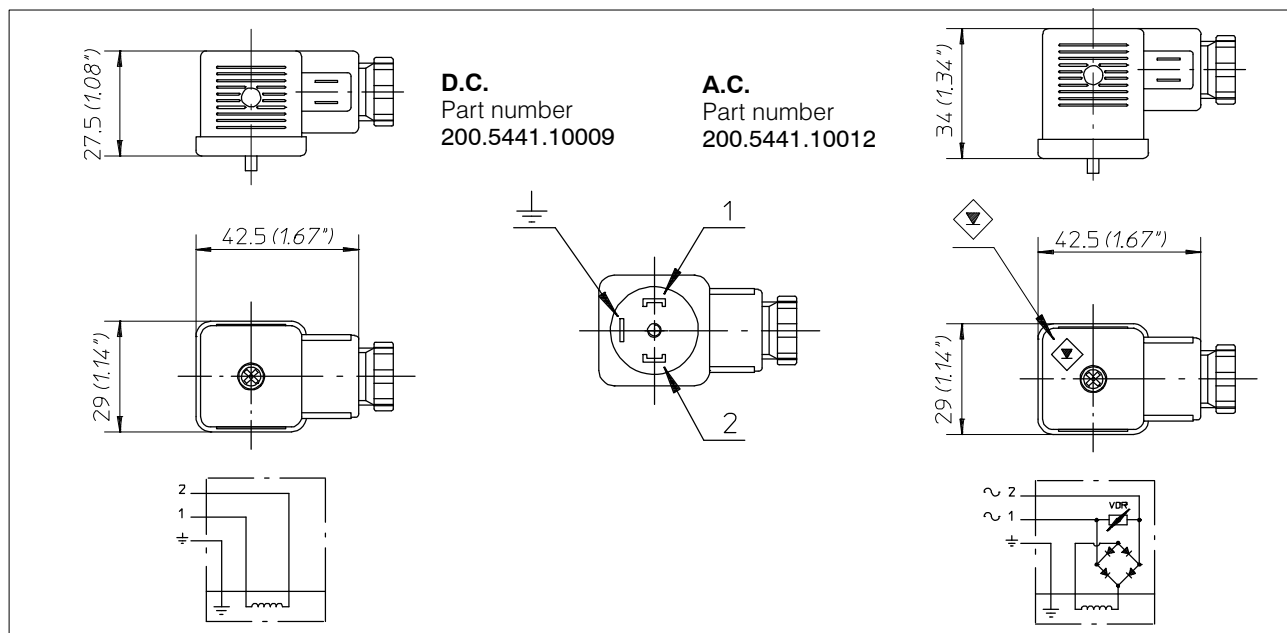

Armour clamp	Pg 9
Ø cable	6 - 8 mm
Diodes	1N 4007 GP
Overvoltage protection	VDR
Connector type	DIN 43650
Number of poles	2 + $\frac{1}{2}$
Supply voltage	max. 220 V
Nom. capacity at contacts	10 Ampere

Max capacity at contacts	16 Ampere
Resistance at contacts	≥ 4 mOhm
Max section of cable	1.5 mm ²
Outer material	Glass fibre reinforced nylon
Protection factor	IP65 (DIN 40050)
Insulation class	C (VDE 0110)
Temperature range	-40° +90°C

5.14 Electromagnetic controls ON-OFF

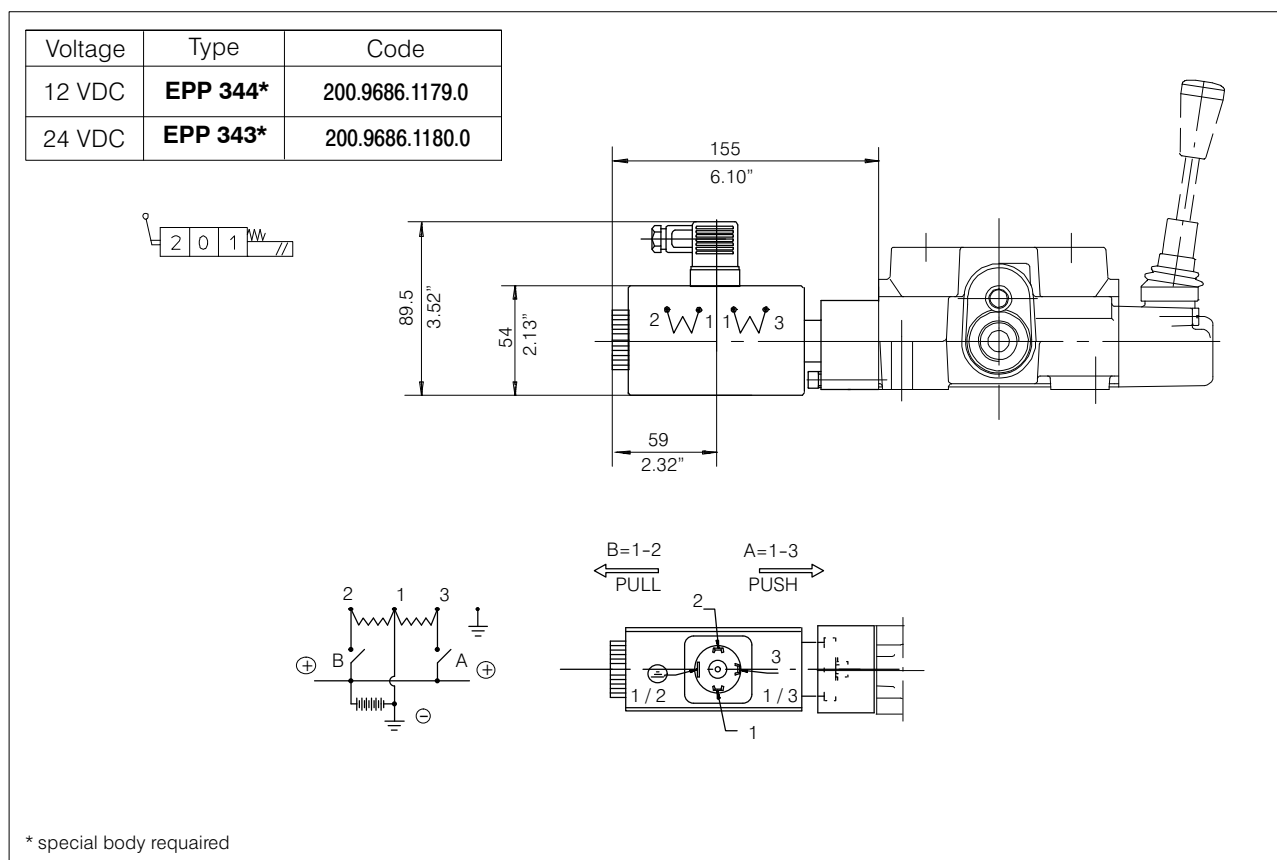

To be used with special spools only: the spool definition is different from the standard one because of the double "P". For example A spool become AP3.
 Ex.: (A spool + 24 VDC positioner)= AP3343

Mechanical and hydraulic features

Max operating pressure 150 bar (2800 PSI)
 Max flow 40 l/min (15 U.S.G.P.M.)
 Max back pressure 5 bar (70 PSI)
 Operating oil temperature 80° C (180° F)

Electromagnetic specification

Input tension 12 V DC [24 V DC] ± 10%
 Power consumption 60 W
 ED: 100 %

Ohms resistance (cold T°): 2.4 Ω [9.6 Ω]
 Ohms resistance (stabilized T°): 3.1 Ω [12.5 Ω]
 Intensity of current (cold T°) 5 A (2.5 A)
 Intensity of current (stabilized T°) 3.8 A (1.9 A)
 Ambient operating temperature range: -25°C/+60°C
 Average stabilized coil temperature operated continuously +105°C
 The above mentioned average temperature is obtained with a nominal voltage of 12 V (24 V), with an ambient temperature of 25° C and with an electromagnet assembled on an hydraulic valve with oil circulation.
 Insulation class:
 according to VDE 0580 standard H
 Electrical connection:
 with Hirschmann connector per DIN 43650 IP 65

info.it@bucherhydraulics.com

www.bucherhydraulics.com

© 2022 by Bucher Hydraulics S.p.A., IT - 42124 Reggio Emilia.

All rights reserved.

Data is provided for the purpose of product description only, and must not be considered as warranted characteristics in the legal sense. The information does not relieve users from the duty of conducting their own evaluations and tests. Because the products are subject to continual improvement, we reserve the right to amend the product specifications contained in this catalogue.

Classification: 430.300.000

200-P-991210-EN-04/01.2022

HDM18

67/220