

8 Sectional directional control valves HDS11

8A Standard valves



OIL SOLUTIONS

PO Box 38
Strathfieldsaye, VIC, 3551
1800 OIL SOL
1800 645 765

sales@oilsolutions.com.au

www.oilsolutions.com.au

"For All Your Hydraulic Needs"



Contents

8A.1	General specification	104
8A.2	Dimensional data	105
8A.3	Performance curves	106
8A.4	Inlet and outlet covers	108
8A.5	Adjustable direct acting Relief Valve RV	108
8A.6	End covers	109
8A.7	Sectional bodies	110
8A.8	Spool charts	112
8A.9	Hydraulic circuits	112
8A.10	Spool positioners	112
8A.11	Lever styles	116
8A.12	Port relief and anti-cavitation valves	119
8A.13	Hydraulic-Pneumatic control ON-OFF	120
8A.14	Hydraulic control	120

8A.1 General specifications

Technical specification		
Max flow rate	l/min U.S.G.P.M.	45 12
Max continuous operating pressure supply port P	bar PSI	250 3600
Max intermittent peak pressure work port A/B	bar PSI	320 4600
Max back pressure tank port T	bar PSI	30 430
Oil temperature	° C ° F	-10 to +80 14 to 180
Oil viscosity	mm ² /s	16 to 75
Oil filtration	μ	≤ 30

Spool leakage at 100 bar (1450 PSI), Temp. 50° C (120° F), viscosity 27 mm ² /s:		
Maximum	cm ³ /min Cu. In./min	12 0.854
Average	cm ³ /min Cu. In./min	6 0.427

Number of spools	1 to 10
Adjustable direct operated relief valve (tamper-proof seal available on request)	RV
Load hold check valve in each section	LC
Cartridge anti-shock, anti-cavitation and service relief valve	OA-UC-C
Mechanical release check valve	RSM1

8A.1.1 Weight

Version	kg	lb
Inlet with RV and P	1	2.21
1 spool section (standard without options)	1.30	2.86
End cover standard	065	1.43
End cover with T and H.P.C.O.	075	1.65

8A.1.2 Material specification:

Body: High strength cast-iron.
Spool: Hardened steel - Chrome plated.
Seals: Buna "N".

8A.1.3 Standard features:

- 1) Internal load holding check valves (prevent reverse flow through valve when shifting)
- 2) Parallel circuit.
- 3) Balanced interchangeable spools (provides minimum leakage, smooth operation)
- 4) Wide selections inlets, work ports, and outlets threaded ports.
- 5) Negative overlapping of the spool.

8A.1.4 Optional features available:

- 1) Open or closed centre positions, 3 or 4 way operations, 3 or 4 position (float position), full open centre (motoring spool) and other spool options.
- 2) Carry over.
- 3) Series connection and priority pressure.
- 4) Pressure compensated flow control.
- 5) Complete lever assembly.

8A.1.5 Symbols:

P: inlet port
T: outlet port
A/B: work ports
H.P.C.O.: carry-over
RV: relief valve
P₁T₁: top inlet and outlet
3.10.2: spool position
P: pressure line
T: exhaust line
E: centre line (by pass).

8A.2 Dimensional data

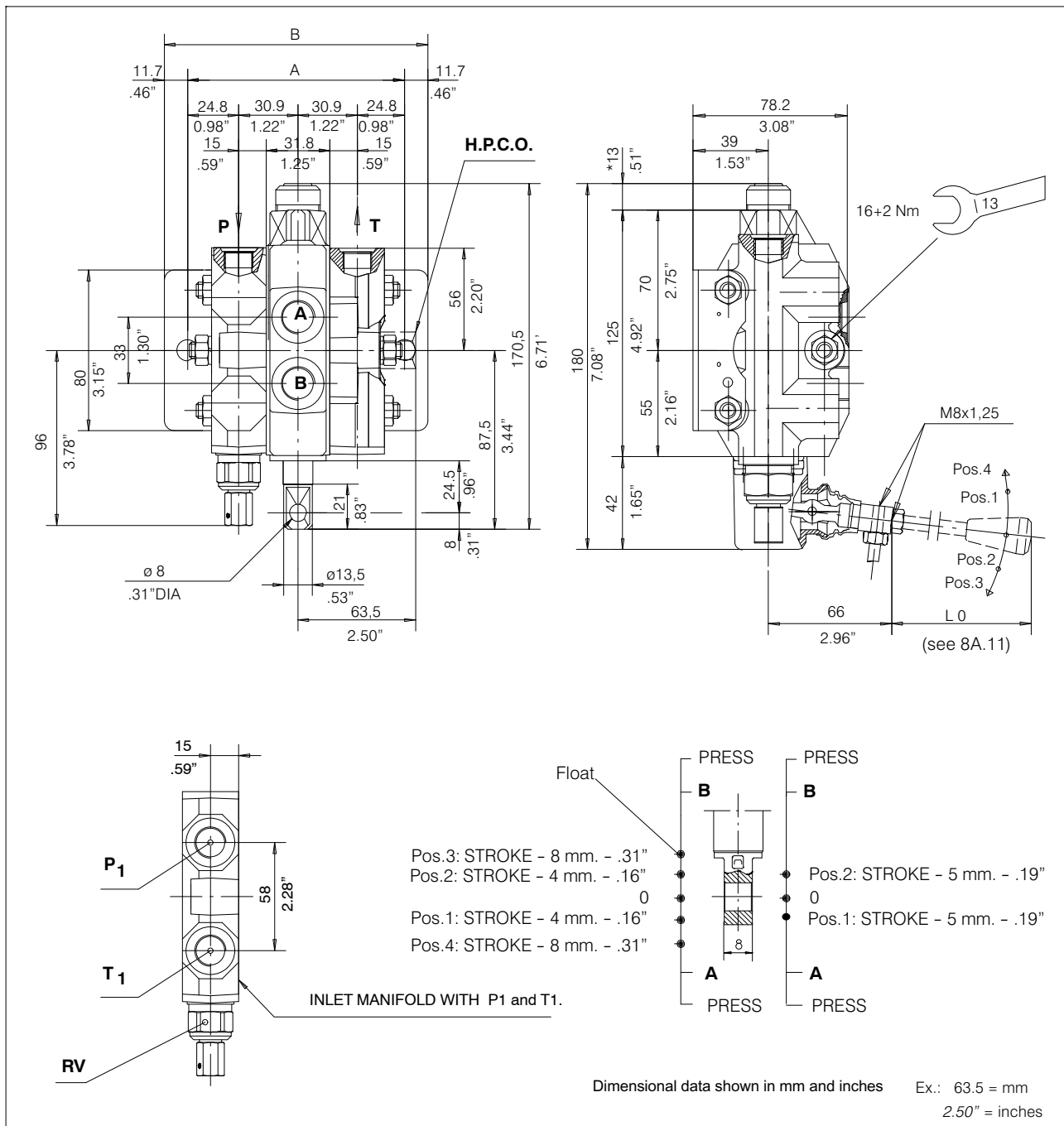

N. of sections		1	2	3	4	5	6	7	8	9	10
Dimension	A	111.4	143.2	175	206.8	238.6	270.4	302.2	334	365.8	397.6
		4.38"	5.64"	6.89"	8.14"	9.39"	10.64"	11.90"	13.15"	14.40"	15.65"
Dimension	B	134.8	166.6	198.4	230.2	262	293.8	325.6	357.4	389.2	421
		5.31"	6.56"	7.81"	9.06"	10.31"	11.57"	12.82"	14.07"	15.32"	16.57"

8A.3 Performance curves

Oil: Shell Tellus T37
 Temperature: 50° C (120° F)
 Viscosity: 27 mm²/s

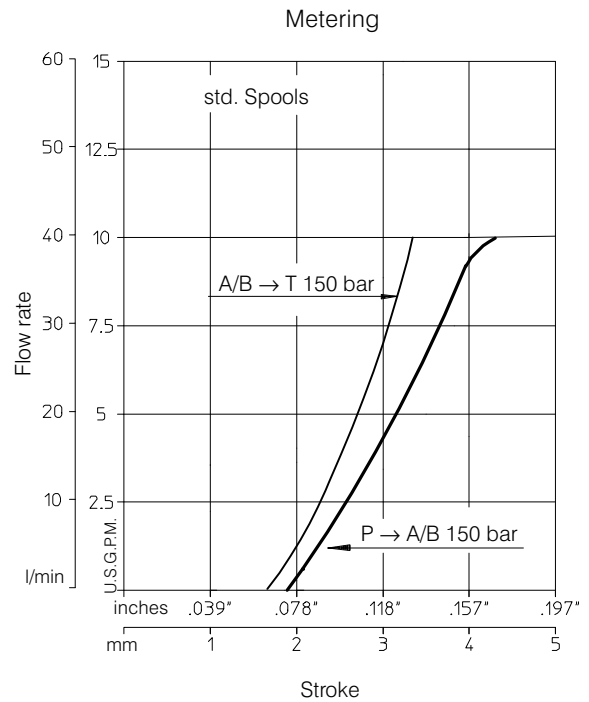
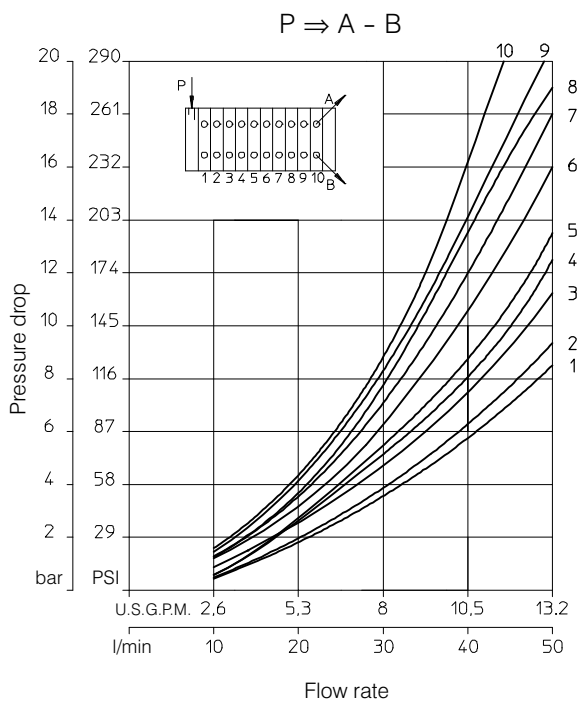
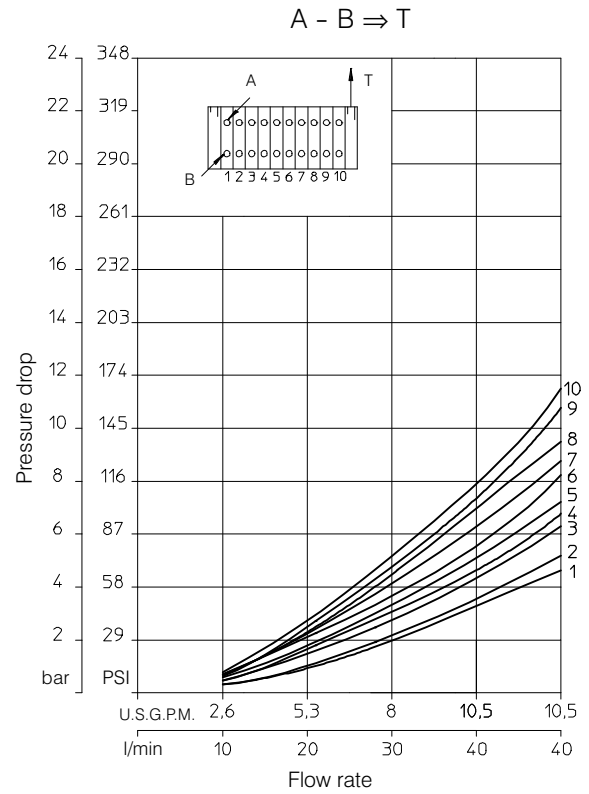
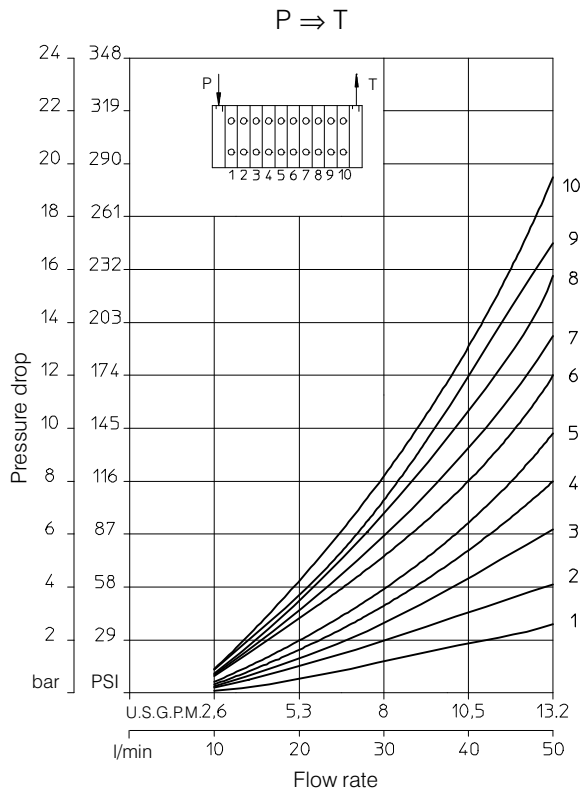

Oil: Shell Tellus T37
 Temperature: 50° C (120° F)
 Viscosity: 27 mm²/s

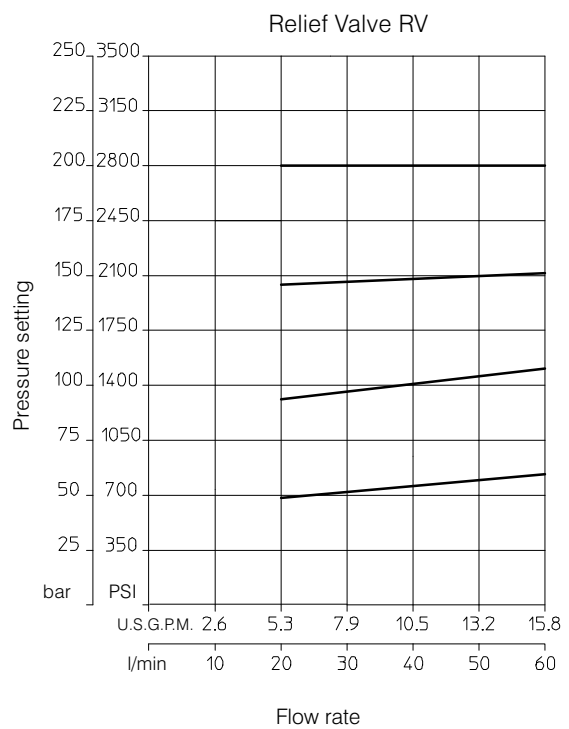
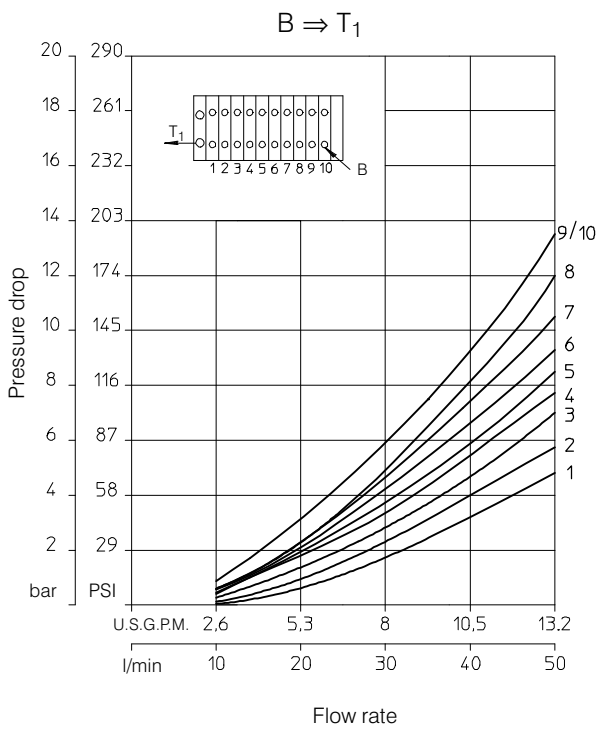
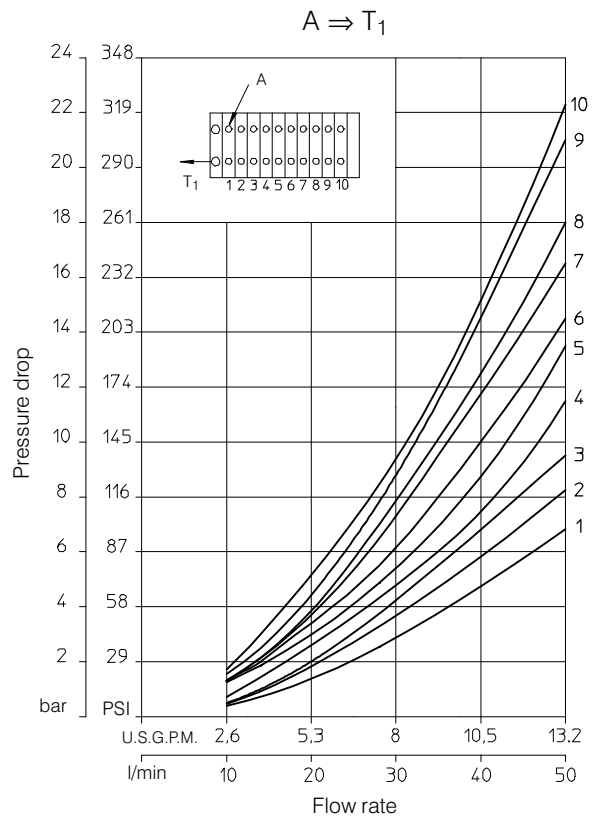
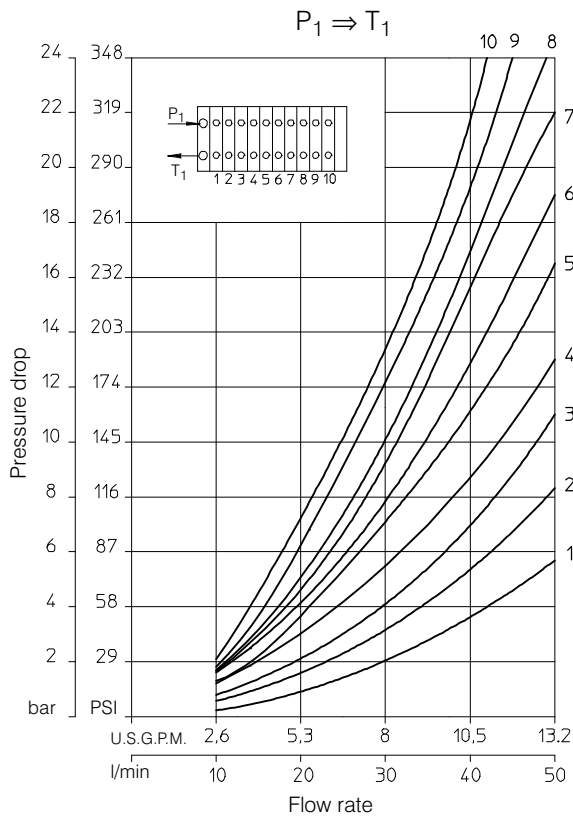

8A.4 Inlet and outlet covers

8A.4.1 Inlet manifold (standard) with P and RV

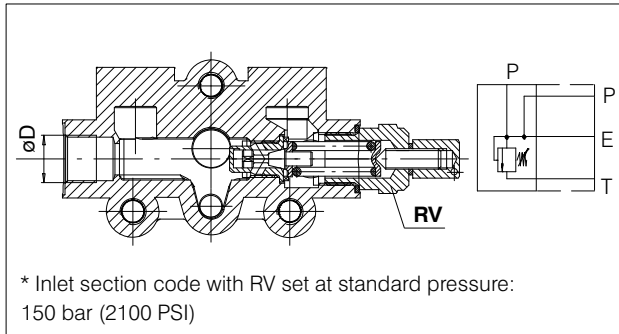

Ø D	Type	Code
SAE6	T06	* 200931060020
SAE8	T07	* 200931070030
3/8" BSP	T09	* 200931020020
M18X1.5	T10	* 200931010030

8A.4.2 Inlet manifold with P₁ - T₁ - RV

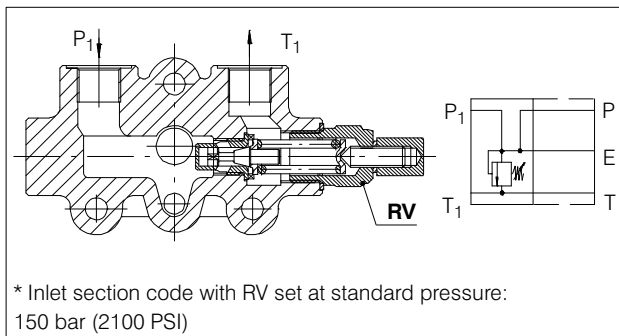

Ø D	Type	Code
SAE6	T11	* 200931060030
SAE8	T12	* 200931070020
3/8" BSP	T14	* 200931020030
M18X1.5	T15	* 200931010020

8A.4.3 Inlet manifold with P₁ - T₁

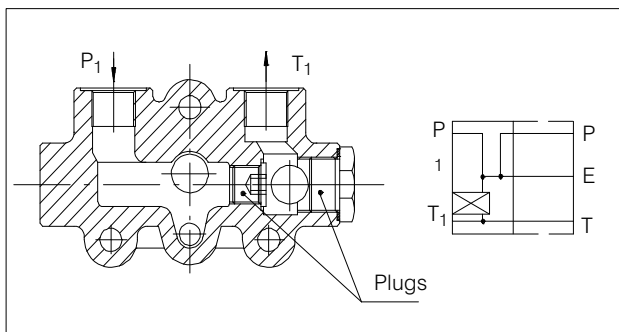

Ø D	Type	Code
SAE6	T16	200931060040
SAE8	T17	200931070050
3/8" BSP	T19	200931020040
M18X1.5	T20	200931010040

8A.5 Adjustable direct acting pressure Relief Valve RV

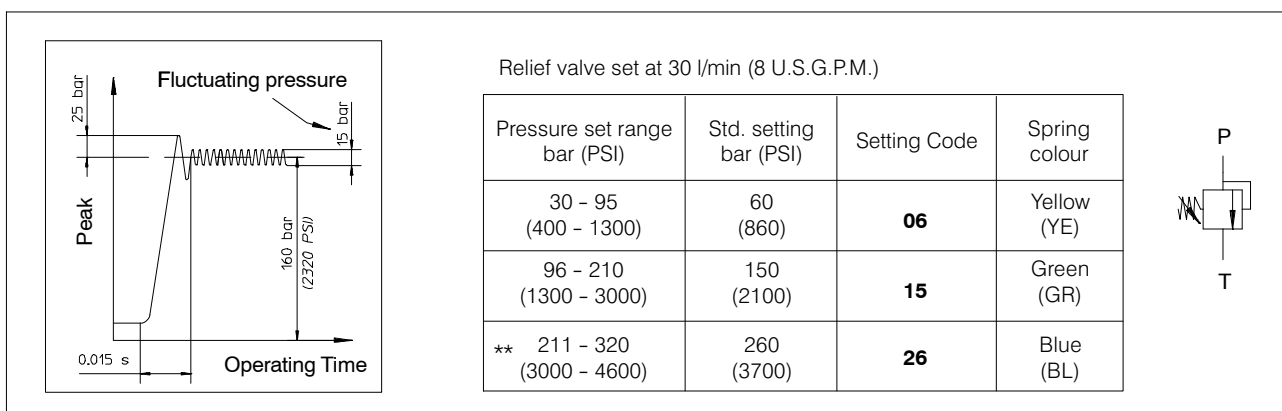

** The maximum operating pressure for each valve series is indicated in the "Technical specification" at the first page of each valve section.

8A.6 End covers

8A.6.1 Outlet manifold (std) with T and open center

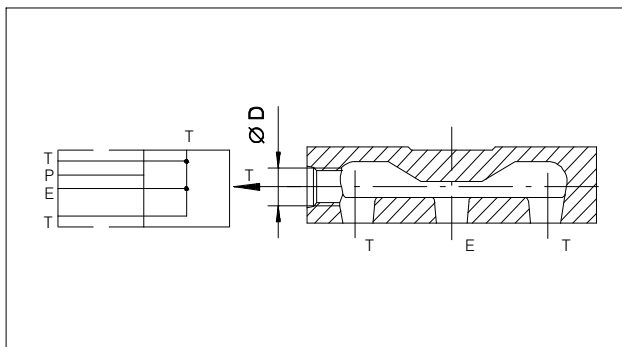

Ø D	Type	Code
SAE6	P01	200630060011
SAE8	P02	200630070010
3/8" BSP	P04	200630020011
M18X1.5	P05	200630010010

8A.6.2 Outlet manifold with T and H.P.C.O. (power beyond)

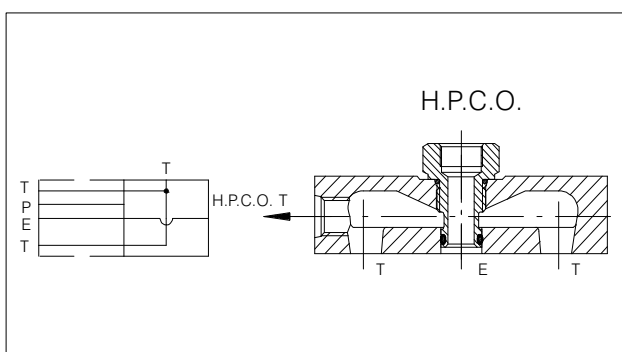

Ø D	Type	Code
SAE6	P06	200930060020
SAE8	P07	200930070020
3/8" BSP	P09	200930020020
M18X1.5	P10	200930010020

8A.6.3 Outlet manifold with open center

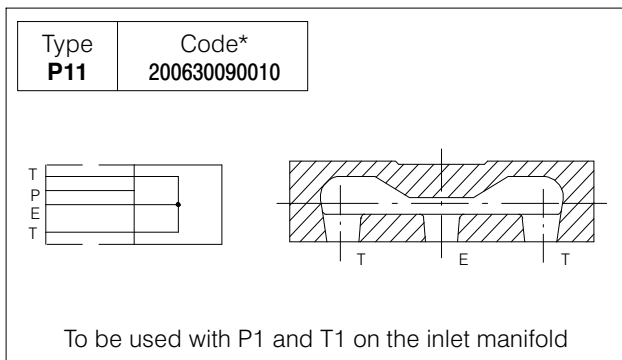

8A.6.4 Outlet manifold with closed center

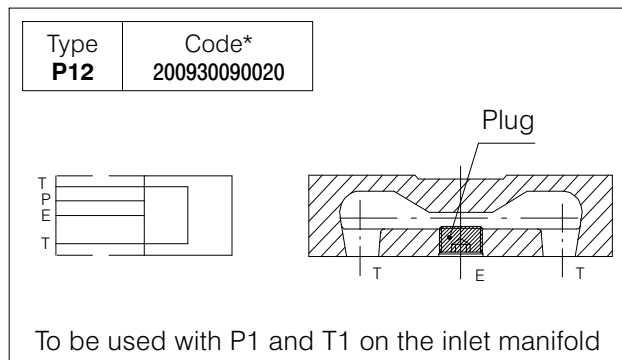

8A.6.5 Outlet manifold with T and closed center

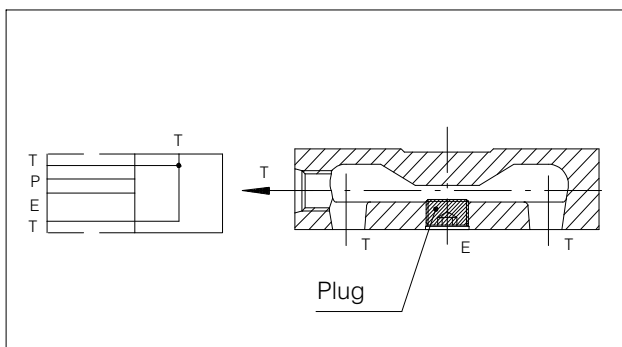

Ø D	Type	Code
SAE6	P13	200930060030
SAE8	P14	200930070030
3/8" BSP	P16	200930020030
M18X1.5	P17	200930010030

8A.7 Sectional bodies

8A.7.1 Standard circuit: parallel

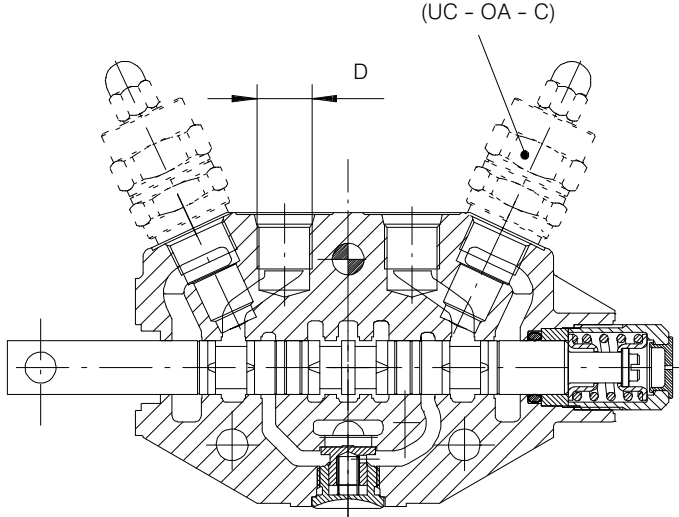

Ø D	Type/Code	
	Standard	Section with valve UC - OA - C
SAE6	K01 200941360510	K06 200941360530
SAE8	K02 200941370270	K07 200941370280
3/8" BSP	K04 200941326240	K09 200941326250
M18X1.5	K05 200941312720	K10 200941312730

cyl. A
cyl. B

P E T

8A.7.2 Optional circuit: series and tandem

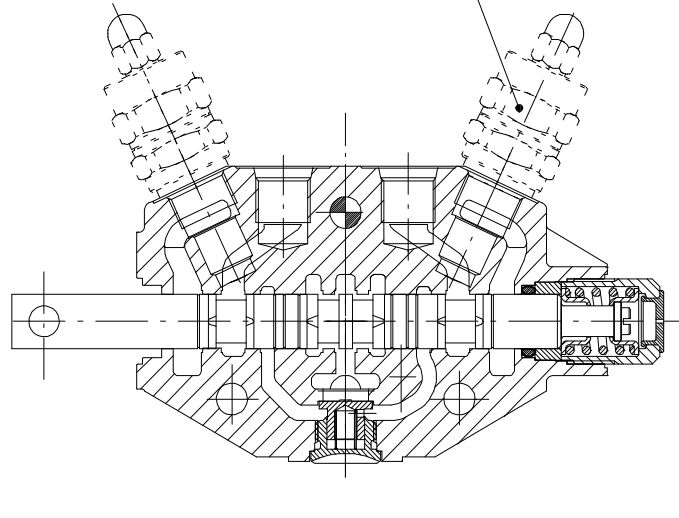

Ø D	Type/Code	
	Standard	Section with valve UC - OA - C
SAE6	K47 200941360520	K52 200941360540
SAE8	K48 200941370290	K53 200941370300
3/8" BSP	K50 200941326260	K55 200941326270
M18X1.5	K51 200941312740	K56 200941312750

cyl. A
cyl. B

P E T

Note: Body code consist of machined casting, seals and hold check valve only. Not to be used for complete valve order.

8A.7.3 Check valves with mechanical release RSM1 on A/B ports

The check valve taper seal is released by means of a taper on the spool and by a push rod.

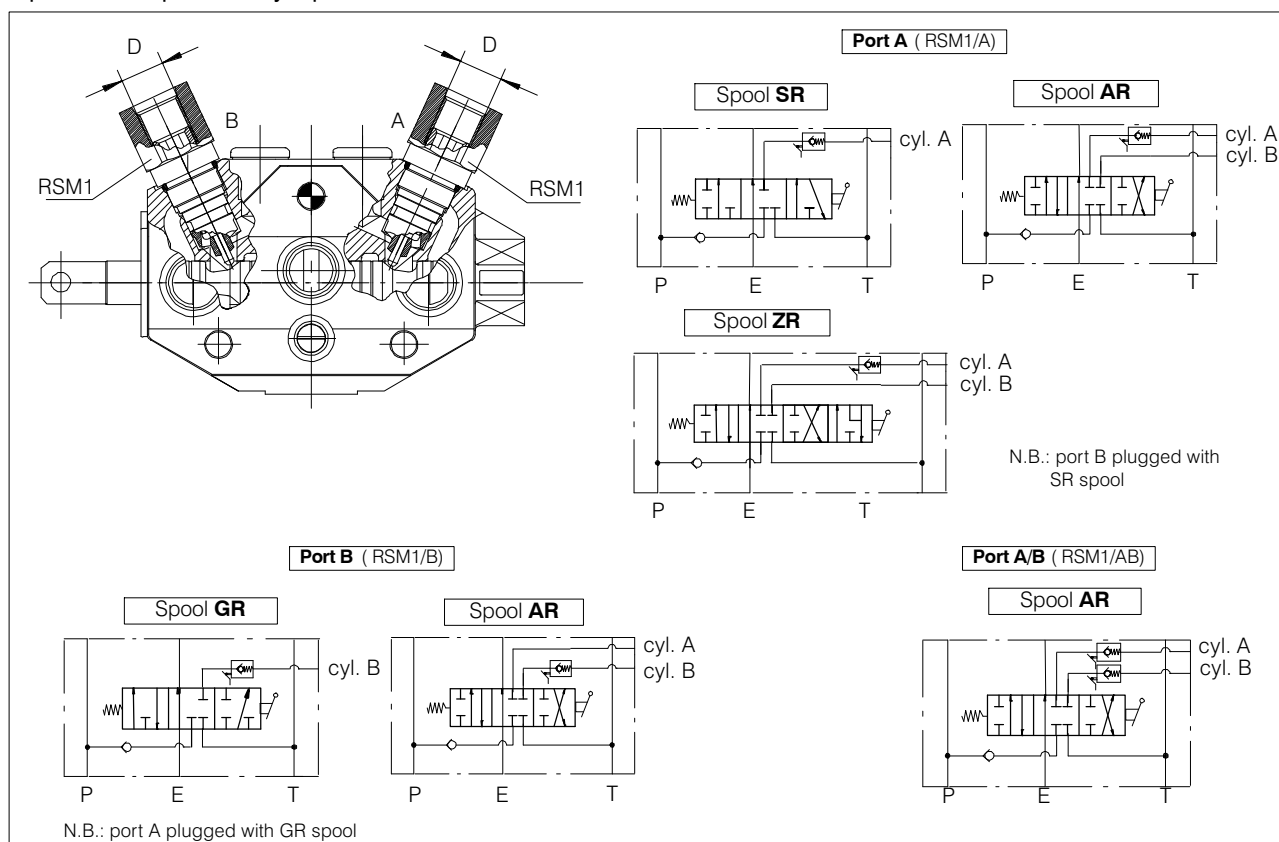

8A.7.4 Directional control valve bodies for RSM1 valve

Ø D	RSM1/A		RSM1/B	RSM1/A-B	RSM1 Code
	Spool SR-AR	Spool ZR	Spool GR-AR	Spool AR	
	Type/Code	Type/Code	Type/Code	Type/Code	
SAE6	K65 200941360610		K66* 200941360620	K62* 200941390140	200787601920
3/8" BSP	K63 200941320340	K40** 200941320330	K64* 200941320350		200787601910
M18X1.5	K60 200941312790	K70** 200941310460	K61* 200941312800		200787601900

* : K61 - K62 - K64 - K66 need special lever L153 - L353

** : K40 - K70 need special lever L175-L375

Note: Body code consist of machined casting, seals and hold check valve only. Not to be used for complete valve order.

8A.8 Spool charts

Spool scheme	Spool features	Type
	4 way - 3 position A/B closed E open by pass	A AR**
	High metering spool (max flow suggested 15 l/min.)	AS
	4 way - 3 position A/B-E closed	B
	4 way - 3 position A/B to tank in neutral E open by pass	C
	3 way - 3 position B closed E open by pass	G GR**

	3 way - 3 position A closed E open by pass	S SR**
	4 way - 3 position series connection	X
	4 way - 4 position 4 th floating position	Z ZR**
	4 way - 4 position 4 th floating position	WW *

* : "WW" spool require special body (K...), positioner (240) and lever (L192)
** : special body required

8A.9 Hydraulic circuits

Standard parallel circuit

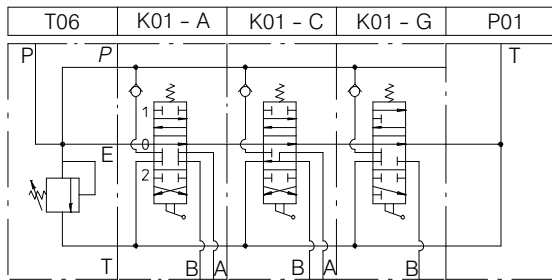

Optional tandem circuit

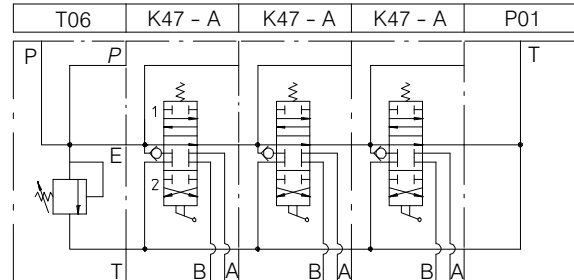

Optional series circuit

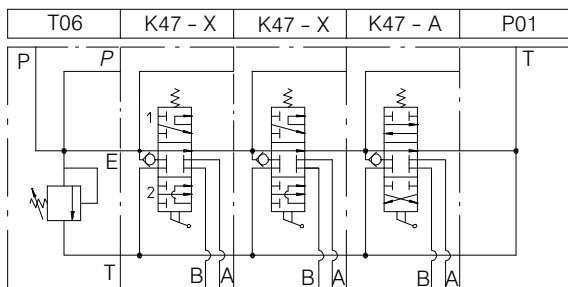

Combined parallel/series circuit

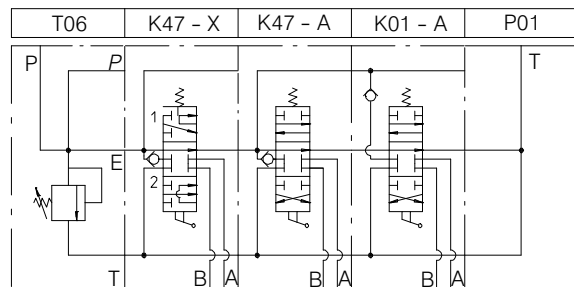

8A.10 Spool positioners

F (N)	Type	Code*
200	01 STD	200768510010
140	79	200768510920

3 position spring return to neutral

Type	Code*
02	200768530010

2 position detent - spring centre

* : code without plastic plug; plastic plug code: 2006780.0008.0
Code F (N)**: force in Newton (N) needed to operate the spool

Type 03	Code* 200768520010
-------------------	-----------------------

3 position detent

Type 04	Code 200768540030
-------------------	----------------------

4 position float

Plastic plug code: 2006780.0009.0

Type 05	Code* 200768520050
-------------------	-----------------------

2 position detent

Type 06	Code* 20076851005.0
-------------------	------------------------

2 position spring return

Type 07	Code* 2007685.2027.0
-------------------	-------------------------

2 position detent

Type 12	Code* 200768510210
-------------------	-----------------------

2 position spring return

Type 15	Code* 200768511090
-------------------	-----------------------

2 position spring return

Type 16	Code* 200768511100
-------------------	-----------------------

2 position spring return

* : code without plastic plug; plastic plug code: 2006780.0008.0

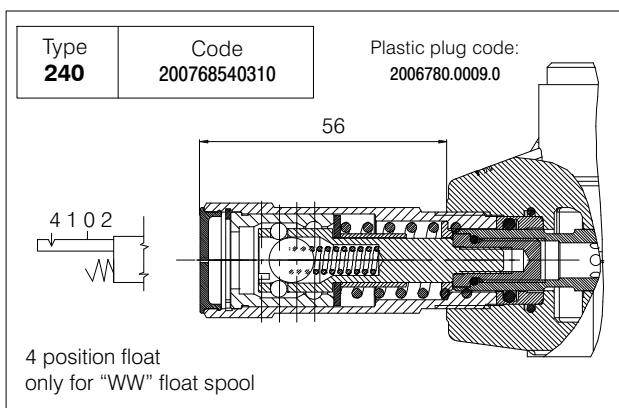
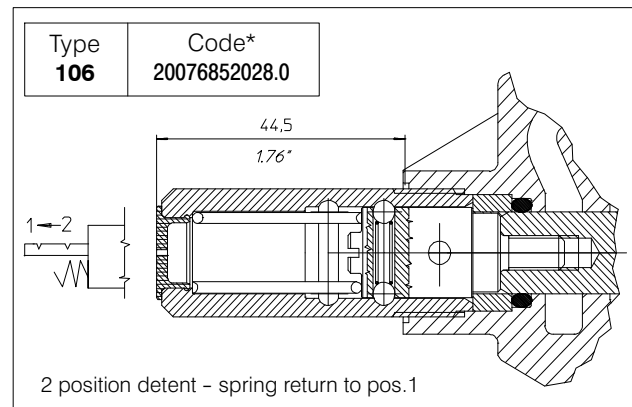
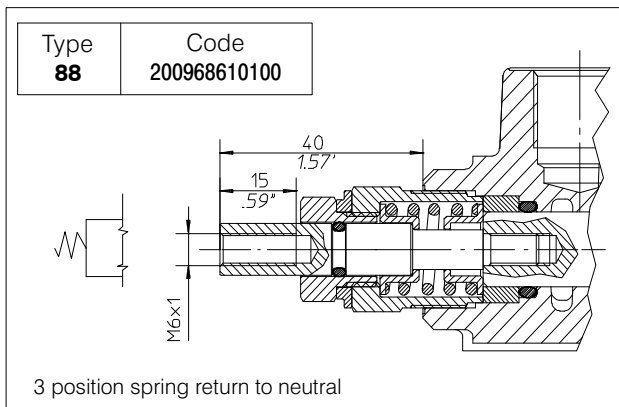
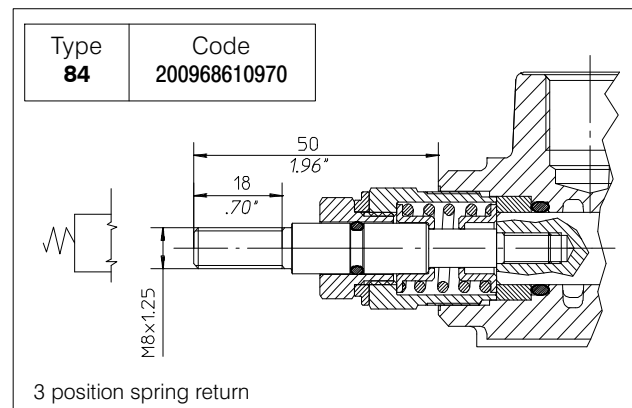
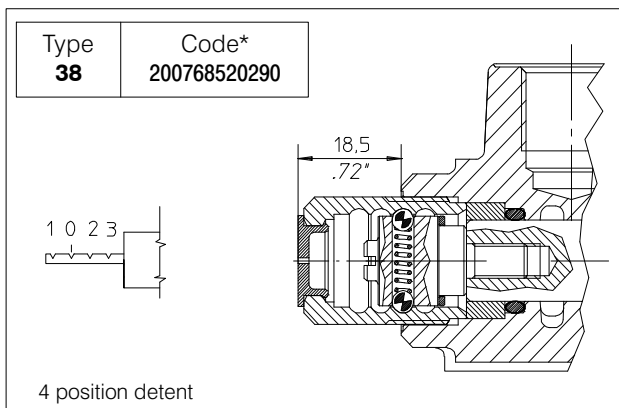
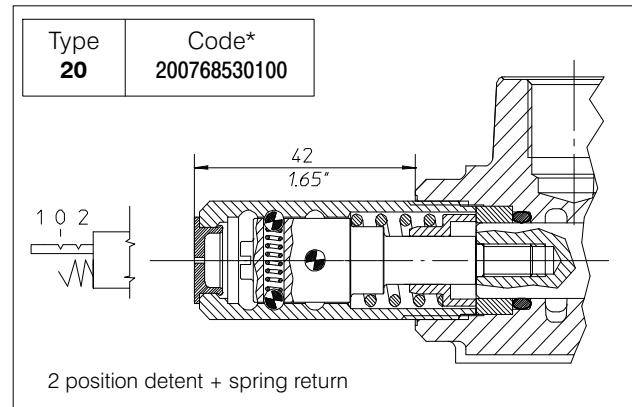
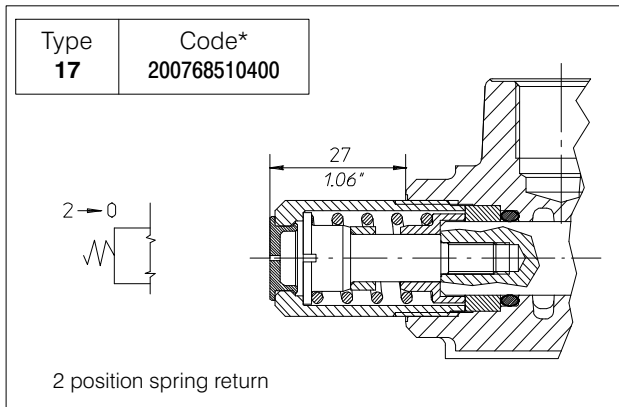

* : code without plastic plug; plastic plug code: 2006780.0008.0

8A.10.1 Microswitch control on each single element

Type 30	Code 200968610500	Microswitch is operated when the spool is in pos. 1		
Type 32	Code 200968610600	Microswitch is operated when the spool is in pos. 2		
Type 34	Code 200968610640	Microswitch is operated when the spool is in pos. 1 and 2		

* The microswitch is supplied only on customer's request

8A.10.2 Single microswitch control for multi-sectional valves (from 1st up to second-last element).

Type 39 (MSF)	Code 200968611390			
-------------------------	----------------------	--	--	--

Microswitch is operated when the spool is in pos. 1 and 2

8A.10.3 Single microswitch control for multi-sectional valves (last element, T side).

Type 40 (MFL)	Code 200968611400				
-------------------------	----------------------	--	--	--	--

Microswitch is operated when the spool is in pos. 1 and 2

* The microswitch is supplied only on customer's request

1 - Positioner 40 must be assembled only on the last element near T port
2 - Positioner 40 require T port plugged. Use T1 on inlet cover

8A.11 Lever styles

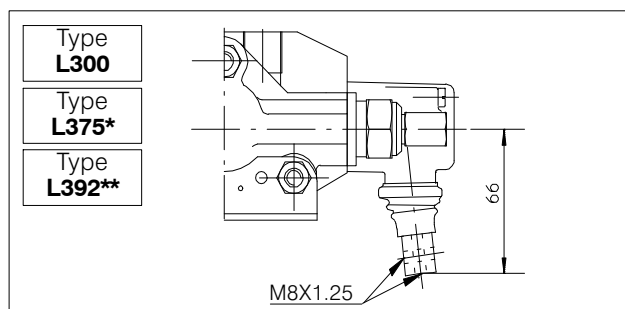
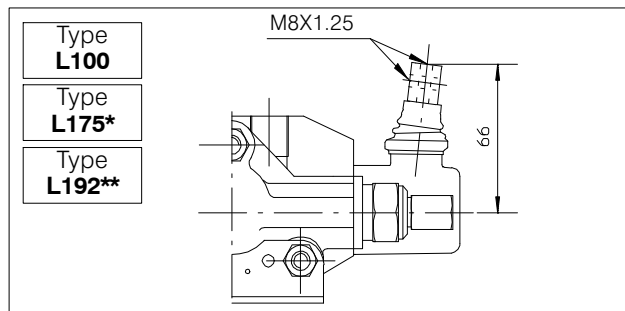
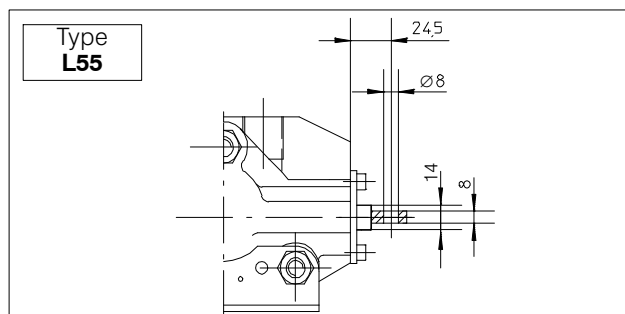

Lo		Type	Code
mm	inches		
150	5.90	AL001	200702210190
200	7.87	AL002	200702210030
250	9.84	AL003	200702210050
300	11.81	AL004	200702210060

*: L175 - L375 only for "Z" spool application

** : L192 - L392 only for "WW" spool application

8A.11.1 Safety levers

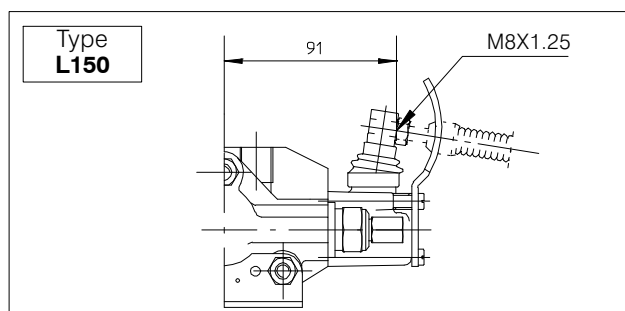
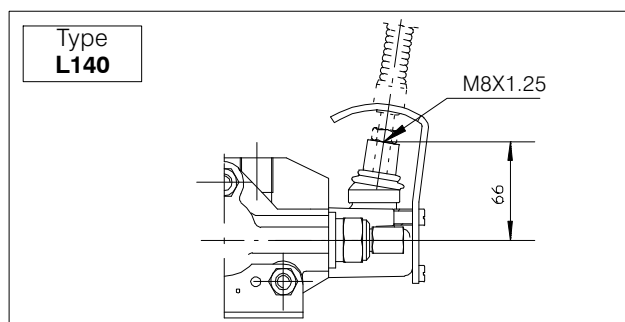

Lo		Type	Code
mm	inches		
160	6.30	AL014	200702210090
180	7.08	AL018	200702210110

8A.11.2 Remote cable control

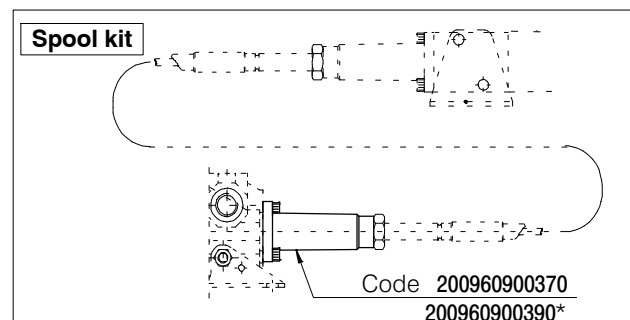
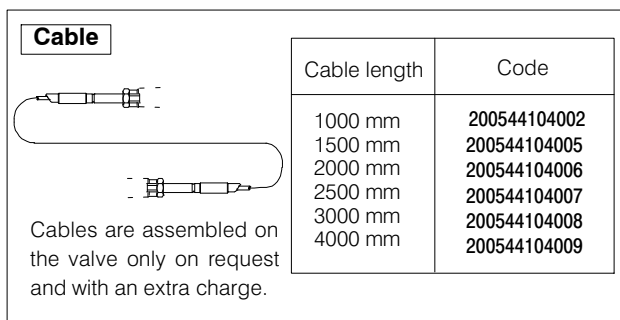
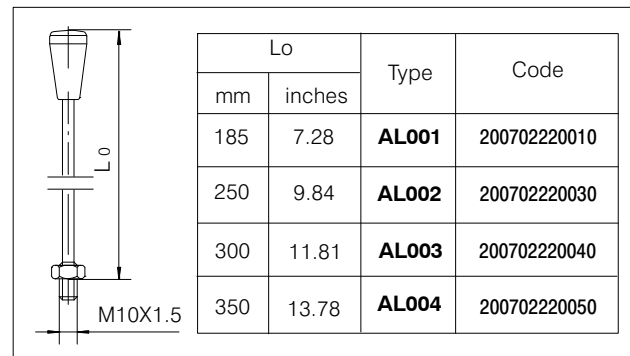
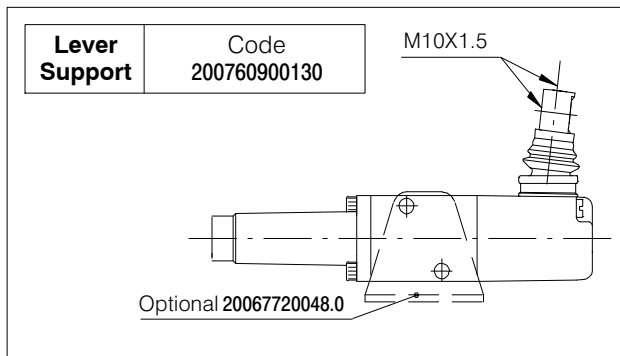

* only for "Z" spool application

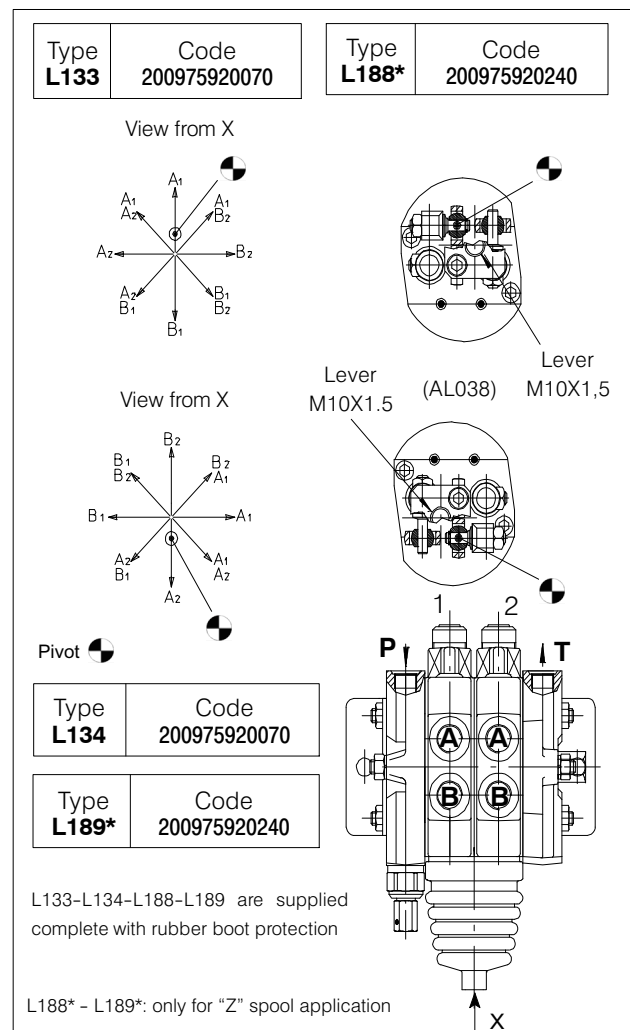
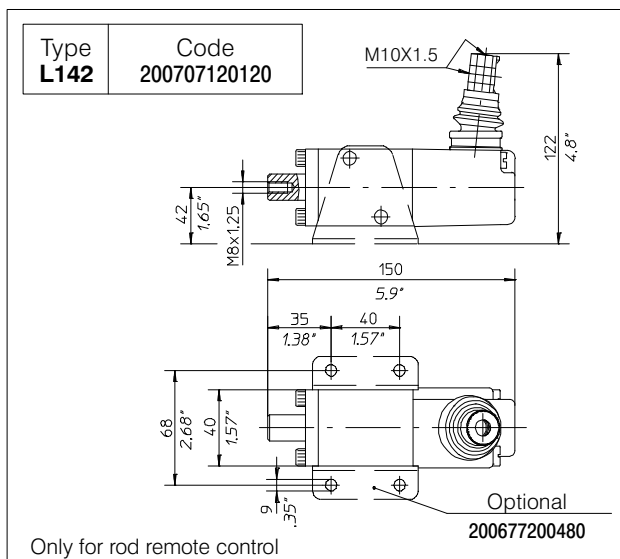

8A.11.3 Cross joystick for dual axis spool control

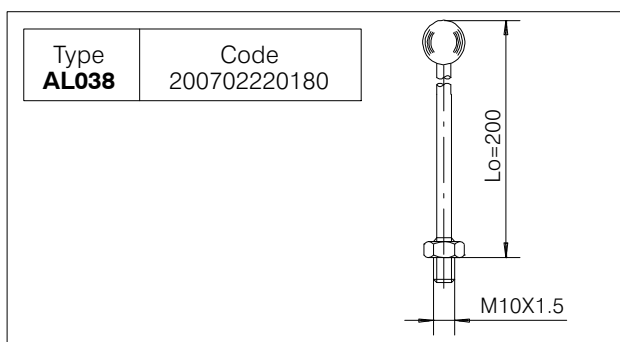

8A.11.4 Cross joystick for dual axis spool control

Type L247-L447	Code 200975920040
--------------------------	----------------------

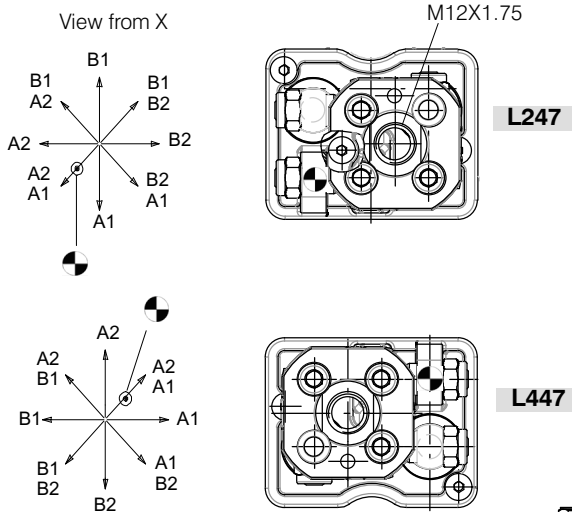

Type L248-L448	Code 200975920050
--------------------------	----------------------

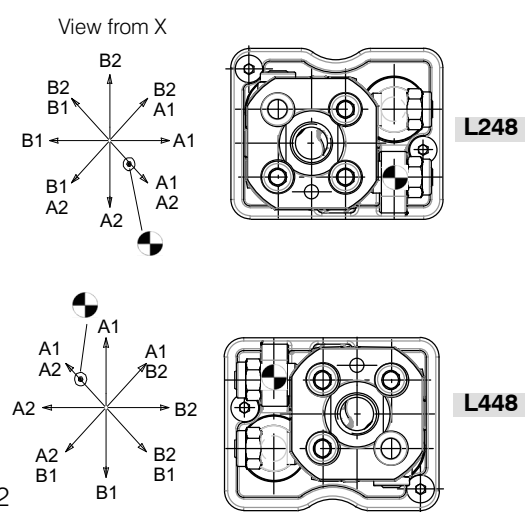

L247-L447-L248-L448 are supplied complete with rubber boot protection
Lever AL010 (M12x1.75) code 200702230040
Pivot

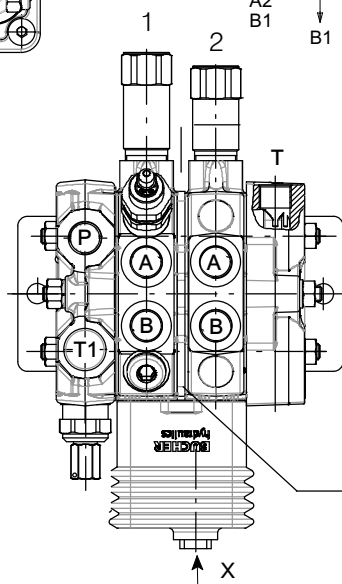

Spacer plate code 200964900470, necessary for L247 - L447 - L248 - L448 - L260 - L460

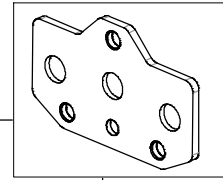

Type L260-L460	Code 200975920411
--------------------------	----------------------

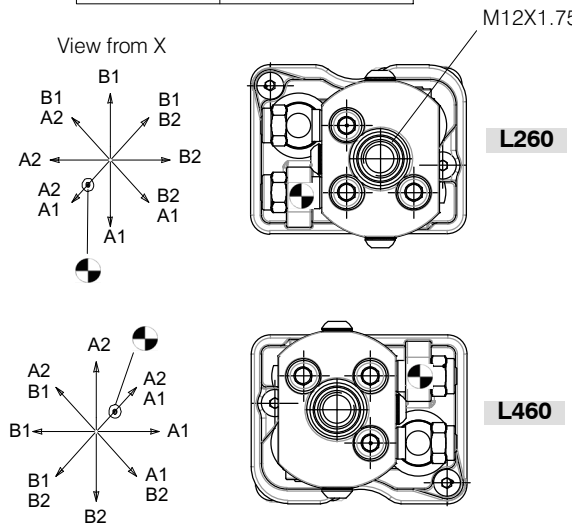

L260-L460 are supplied complete with rubber boot protection

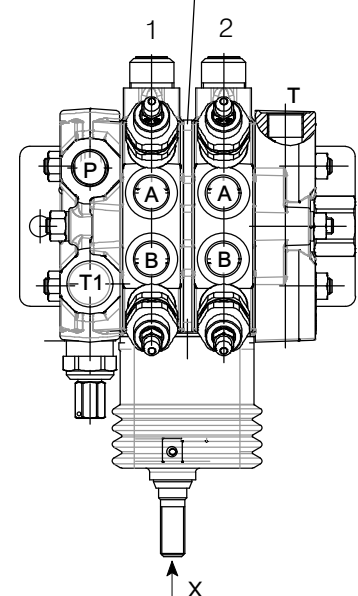

8A.12 Port relief and anti-cavitation valves

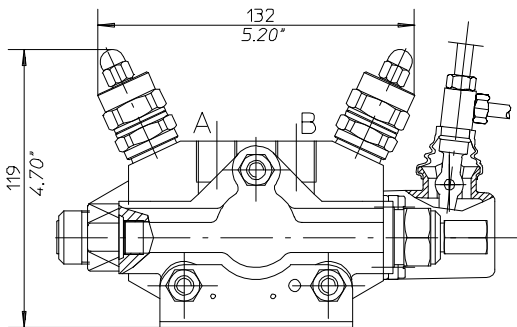

Port relief valve settings

Pressure set range bar (PSI)	Std. Setting bar (PSI)	Type	Spring colour
30 - 130 (400 - 1850)	60 (860)	06	Yellow (YE)
130 - 300 (1850 - 4600)	150 (2100)	15	Green (GR)

8A.12.1 Port relief valve

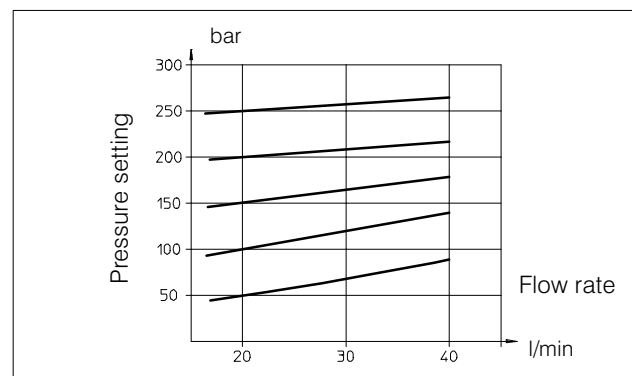
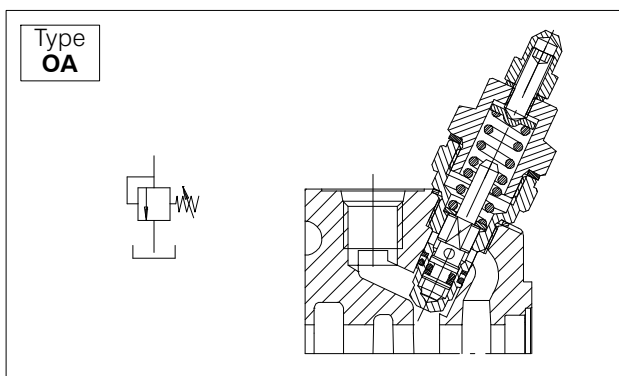

8A.12.2 Anti-cavitation valve

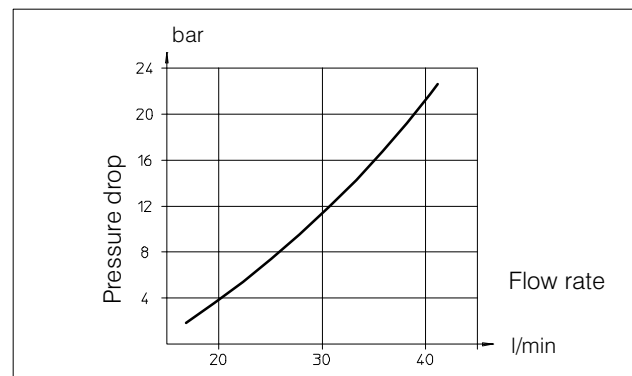
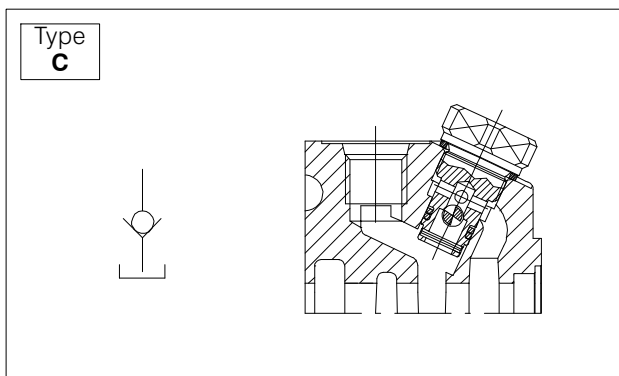

8A.12.3 Combined port relief and anti-cavitation valve

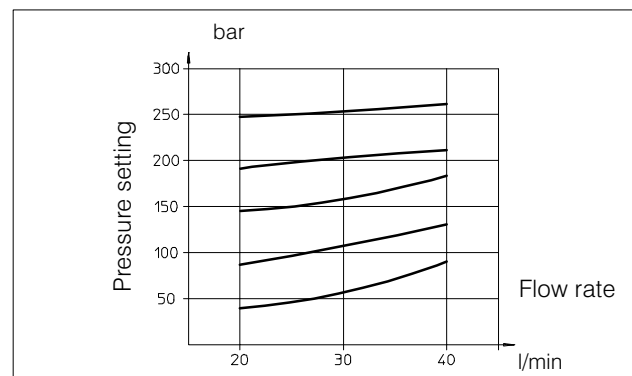
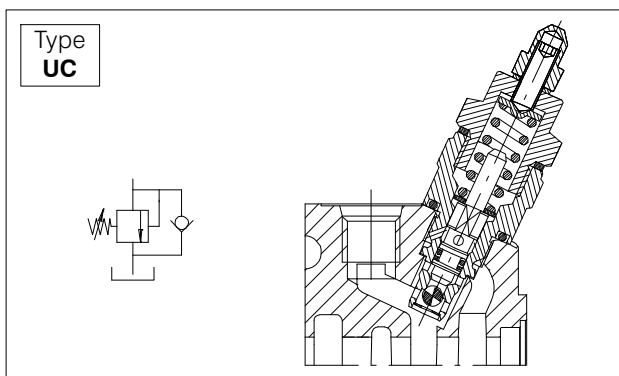

8A.13 Hydraulic-Pneumatic control ON-OFF

Type	Code
HP 24	200968650490

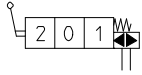

Operating conditions

Hydraulic control:

Pressure range: (bar) Min. 6 - Max. 15
(PSI) Min. 85 - Max. 215

Pneumatic control:

Pressure range: (bar) Min. 6 - Max. 10
(PSI) Min. 85 - Max. 145

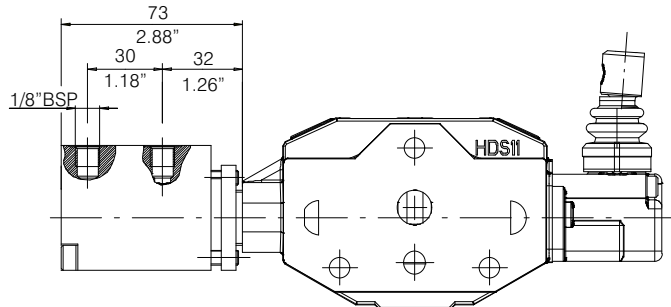

8A.14 Hydraulic control

Type	Code
HP50	200968650583

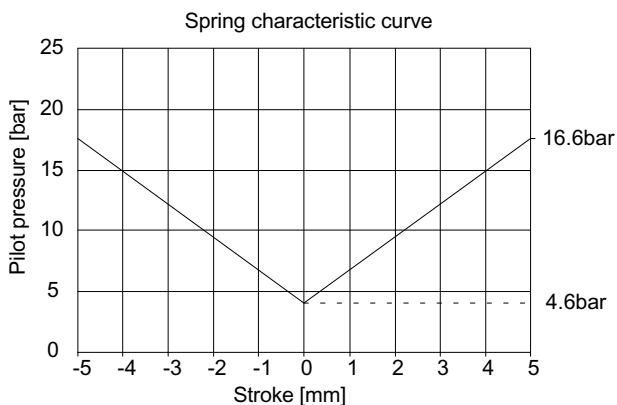
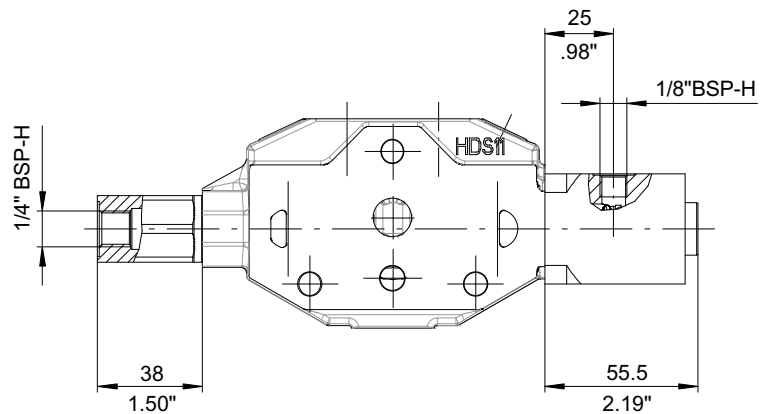
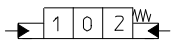

Operating conditions

Hydraulic control:

Pressure range: (bar) Min. 4.6 - Max. 16.6
(PSI) Min. 67 - Max. 241

8B Electromagnetic control EMC (ON-OFF)

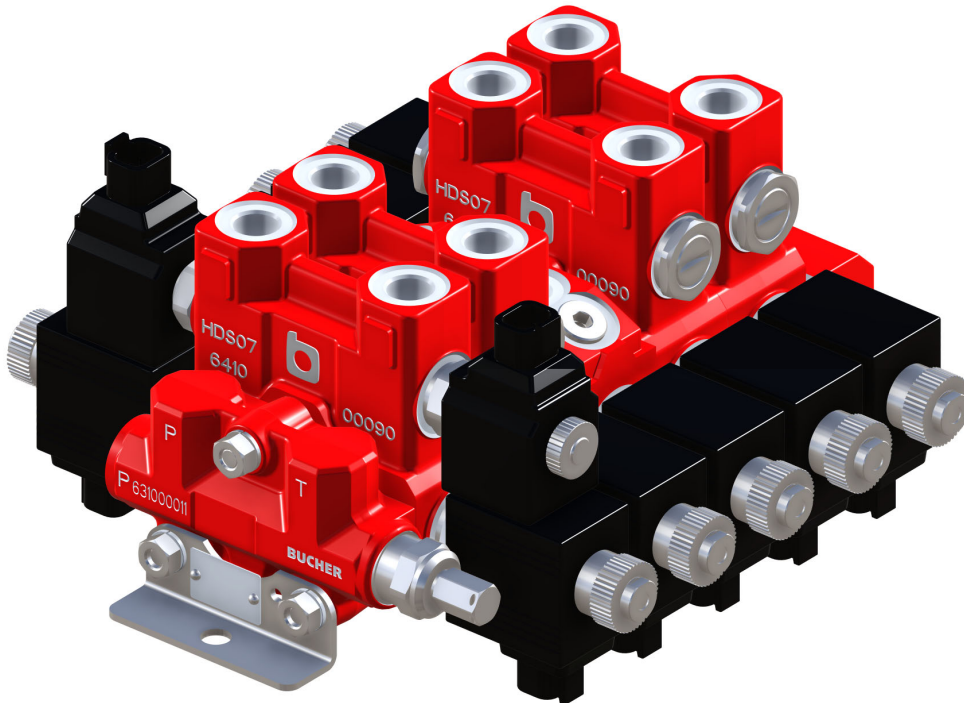

Contents

8B.1	General specification	122
8B.2	Dimensional data	123
8B.3	Performance curves	125
8B.4	Operating limits	126
8B.5	Sectional bodies	127
8B.6	Spool charts	129
8B.7	Spool actions	130
8B.8	4 th Floating Position	131
8B.9	Cartridge valves	133
8B.10	Solenoid operated directional valves	134

8B.1 General specifications

Technical specification		
Max flow rate	l/min U.S.G.P.M.	40 11
Max continuous operating pressure supply port P	bar PSI	250 3600
Max intermittent peak pressure work port A/B	bar PSI	320 4600
Max back pressure on the channel "T"	bar PSI	20 290
Oil temperature	° C ° F	-10 to +80 14 to 180
Oil viscosity	mm ² /sec	20 to 50
Oil filtration	μ	≤ 25

Spool leakage at 100 bar (1450 PSI), Temp. 50° C (120° F), viscosity 27 mm ² /sec:		
Maximum	cm ³ /min Cu. In./min	16 1.138
Average	cm ³ /min Cu. In./min	12 0.854

Number of spools	1 to 10
Adjustable direct operated relief valve (tamper-proof seal available on request)	RV
Load hold check valve in each section	LC
Cartridge anti-shock, anti-cavitation and service relief valve	OA-UC-C

8B.1.1 Material specification:

Body: High strength cast-iron.
Spool: Hardened steel.
Seals: Buna "N".

8B.1.2 Optional features available

Series circuit;
Load sensing circuit;
Spool 3-way or 4-way at 2-3 positions;
Port relief and anti-cavitation valves -OA-UC-C-
Cross port relief valve - AA-
Pilot - Actuated Check Valve - RP-

* for non indicated tension valves, please contact our Sales Department

8B.1.3 Ports

P-T-P₁-T₁-A-B-HPCO (M18X1.5 - 3/8" BSP
-SAE6 - SAE8)

8B.1.4 Input voltages

Continuous Current 12VDC - 24VDC *

8B.1.5 Solenoid specification

Technical specification		
Continuous current voltage	V. D.C.	12 (24) +5% -10%
Power consumption	Watt (W)	36 (37)
Intensity of current	Ampere (A)	3 (1.55)
Resistance	Ohm (Ω)	4 (15.5)
Duty cycle (continuous)	ED	100%
Stabilized temperature at nominal voltage	° C	110
Ambient temperature	° C	-20 to +40

Protection class IP65 (DIN 40050)
Coil insulation class H (VDEO 0580)
STD. connection (DIN 43650)
Manual override.
Explosion-proof version on demand.

8B.1.6 Mechanical specification

Spool diameter 10 mm
Spool stroke 2.50 mm
Overlapping 1.25 mm
Internal passage 10 mm
Dimensional section (width) 40 mm

8B.1.7 Weight

Version	kg	lb
Inlet with RV and P	10	2.23
1 spool section with 2 solenoid	2.50	5.50
1 spool with 1 solenoid	2.10	4.62
End cover with T and HPCO	075	1.65

8B.2 Dimensional data

8B.2.1 Standard circuit: parallel

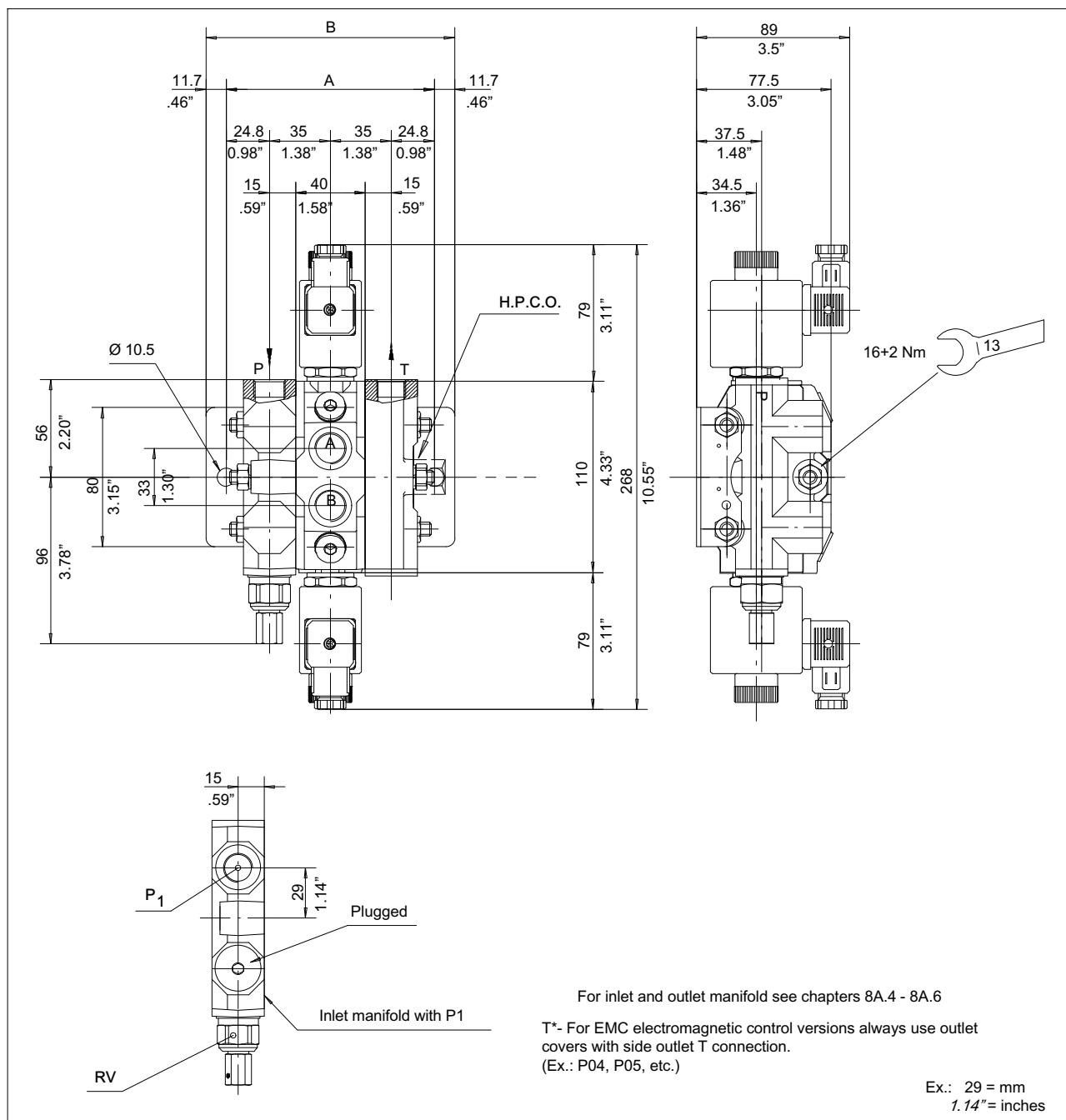

N. of sections		1	2	3	4	5	6	7	8	9	10
Dimension	A	119.6	159.6	199.6	239.6	279.6	319.6	359.6	399.6	439.6	479.6
		4.71"	6.28"	7.86"	9.43"	11.01"	12.58"	14.16"	15.73"	17.31"	18.88"
Dimension	B	143	183	223	263	303	343	383	423	463	503
		5.63"	7.20"	8.78"	10.35"	11.93"	13.50"	15.08"	16.65"	18.23"	19.80"

8B.2.2 Version with SP.../AB valves

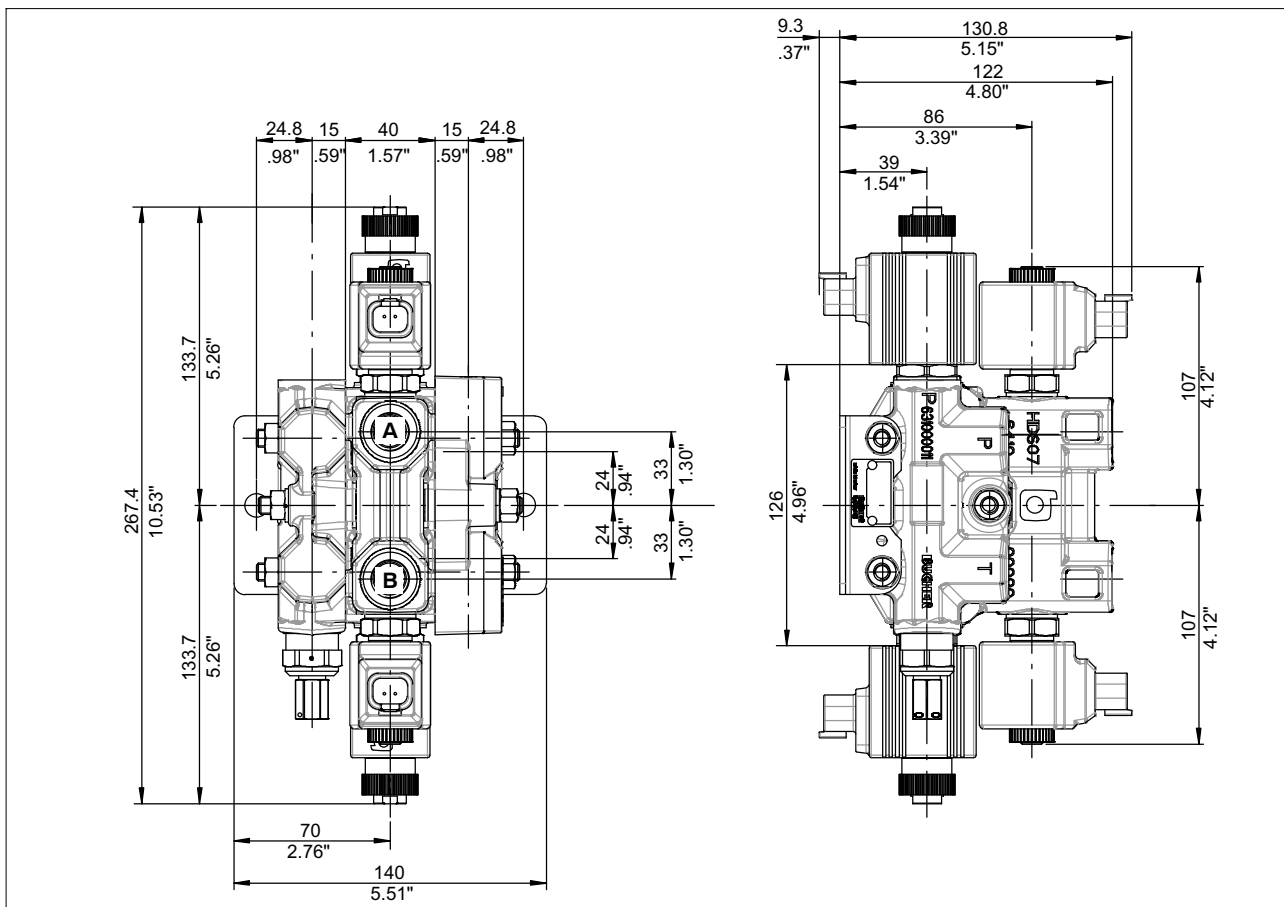

8B.2.3 Version with RP/AB valves

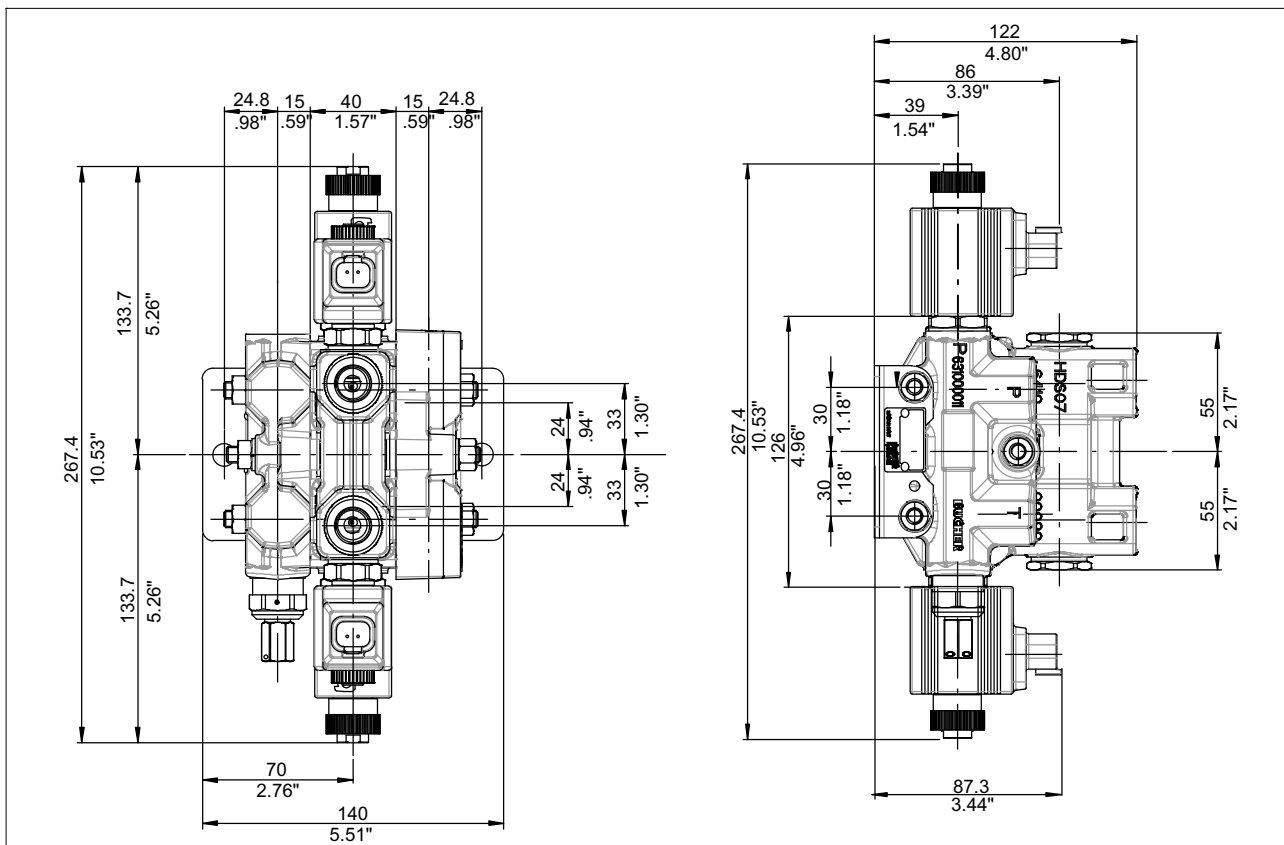

8B.3 Performance curves

Oil: Shell Tellus T37
 Temperature: 50°C (120°F)
 Viscosity: 27 mm²/sec

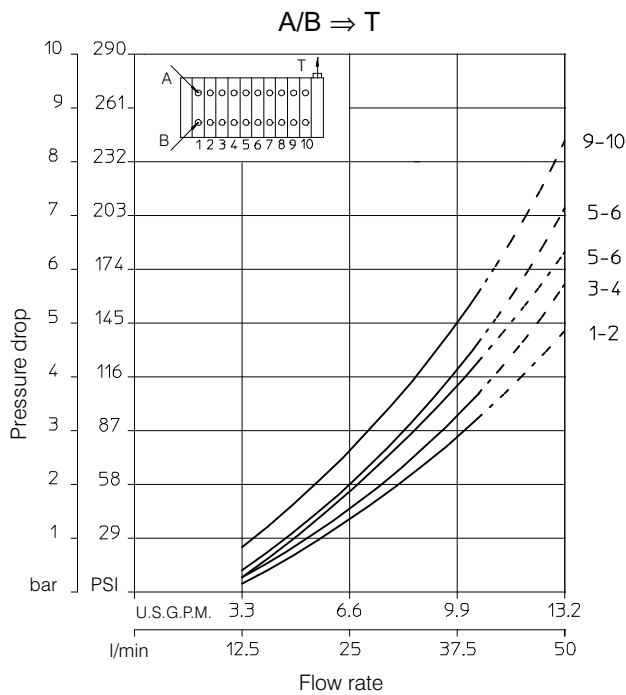
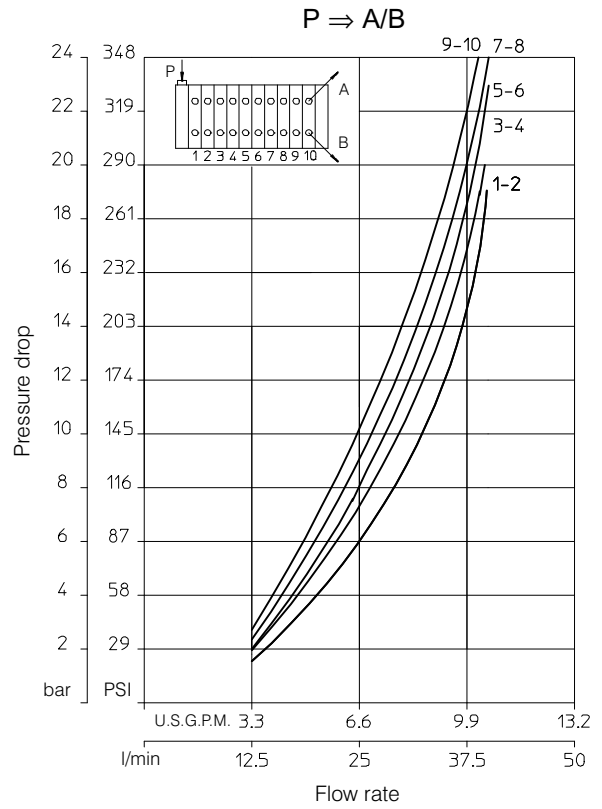
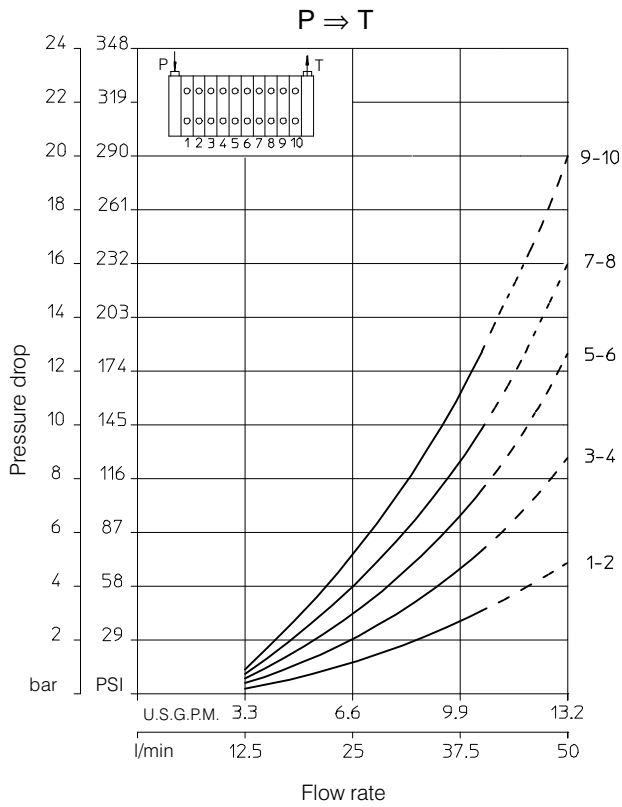

8B.4 Operating limits

Oil: Shell Tellus T37
 Temperature: 50°C (120°F)
 Viscosity: 27 mm²/sec
 Tested with voltage V = -10%

Standard Circuit

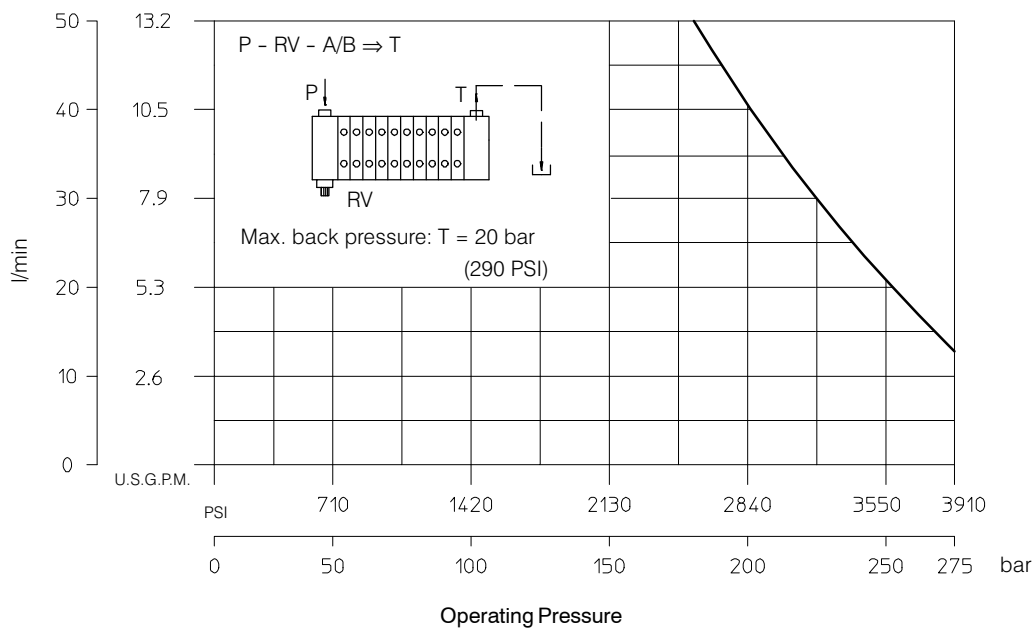

Carry-over Circuit

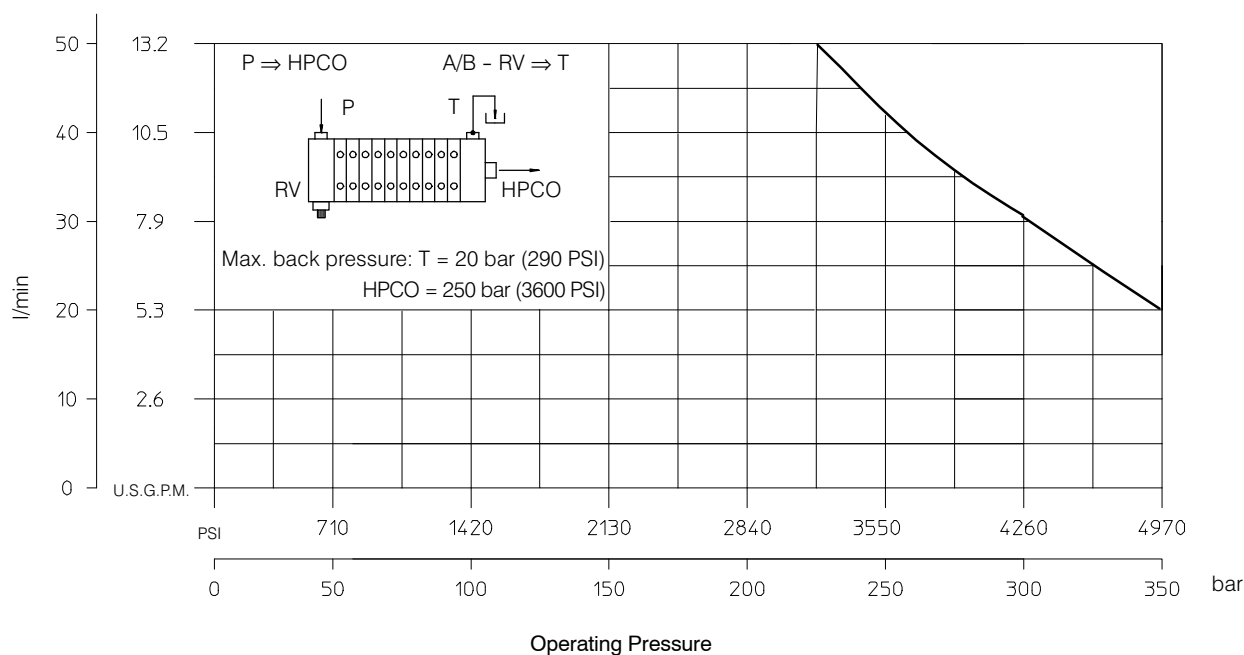

8B.5 Sectional bodies

8B.5.1 Standard circuit: parallel

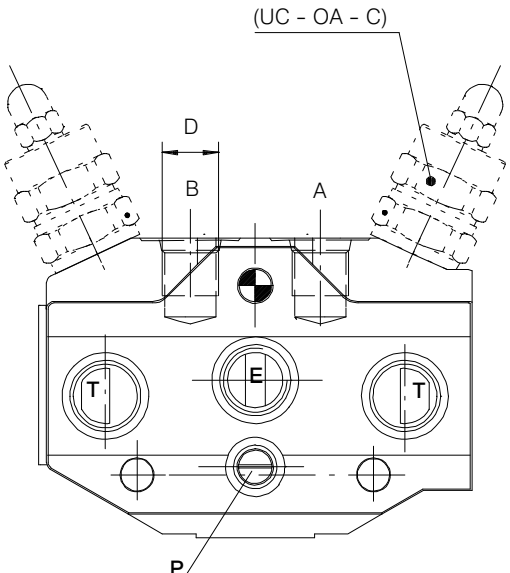

Ø D	Type/Code	
	Standard	Section with valve UC- OA- C
SAE6	K201 200941360550	K211 200941360600
SAE8	K202 200941370310	K212 200941370320
3/8" BSP	K204 200941326280	K214 200941326290
M18X1.5	K205 200941312760	K215 200941312770

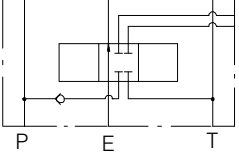

cyl. A
cyl. B

8B.5.2 Optional circuit: series and tandem

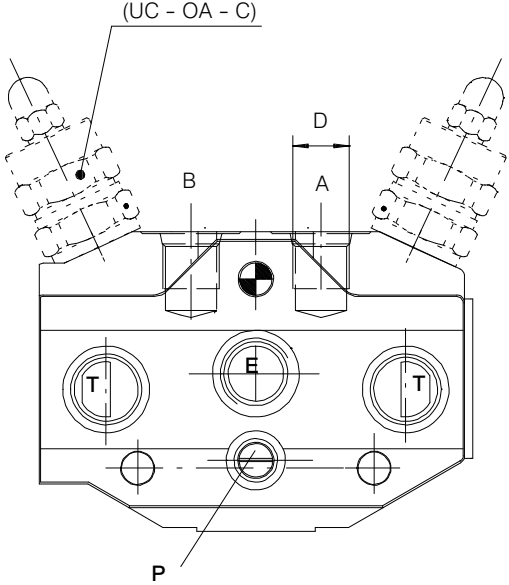

Ø D	Type/Code	
	Standard	Section with valve UC- OA- C
SAE6	K247 200941360660	K252 200941360700
SAE8	K248 200941370390	K253 200941370420
3/8" BSP	K250 200941320420	K255 200941320360
M18X1.5	K251 200941310340	K256 200941310370

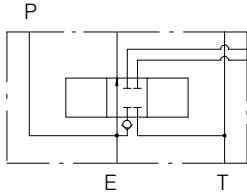

cyl. A
cyl. B

Note: Body code consist of machined casting, seals and hold check valve only. Not to be used for complete valve order.

8B.5.3 Element version with SP817/ TVR valves for standard parallel version

Ø D	Type
SAE6	KH701
3/8" BSP	KH704
M18X1.5	KH705

For SP/SPE817 solenoid valve see chapter 8B.10

Normally open	Type
Double on A-B	TOR/A-B
Single on A	TOR/A
Single on B	TOR/B

Normally closed	Type
Double on A-B	TVR/A-B
Single on A	TVR/A
Single on B	TVR/B

8B.5.4 Element version with RP/AB valves for standard parallel version

Ø D	Type
SAE6	KH711
3/8" BSP	KH714
M18X1.5	KH715

Pilot check valve	Type
Double on A-B	RP/A-B
Single on A	RP/A
Single on B	RP/B

8B.5.5 Emergency manual override



8B.6 Spool charts

Spool scheme	Spool features	Type
	4 way - 3 position A/B closed E open by pass	AE
	4 way - 3 position A/B-E closed	BE
	4 way - 3 position A/B to tank in neutral E open by pass	CE
	4 way - 3 position A closed B to tank in neutral	DE
	3 way - 3 position B closed E open by pass	GE

	4 way - 3 position B closed A to tank in neutral	LE
	3 way - 3 position A closed E open by pass	SE
	4 way - 3 position A/B closed series connection	XE*
	4 way - 3 position A/B to tank in neutral series connection	XCE*
* series body required ** special body required		

8B.7 Spool actions

8B.7.1 Double-Solenoid spring-centered valves

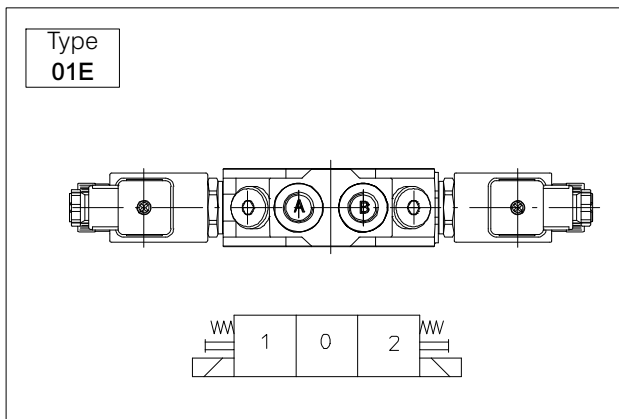

8B.7.3 Single Solenoid spring offset valves

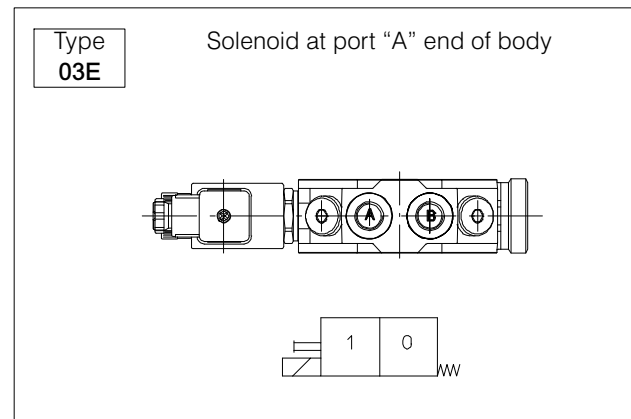

8B.7.2 Single Solenoid spring offset valves

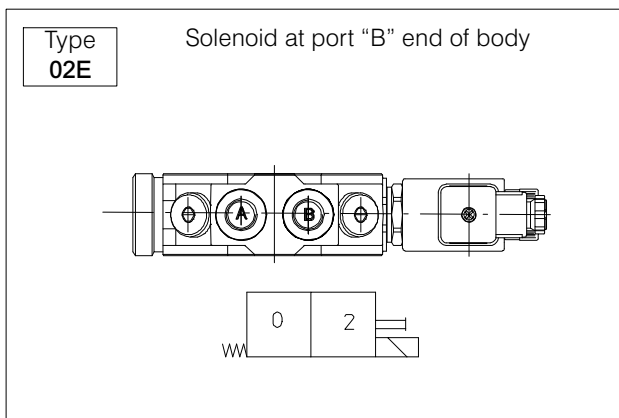

8B.7.4 Double Solenoid, two detent position valves*

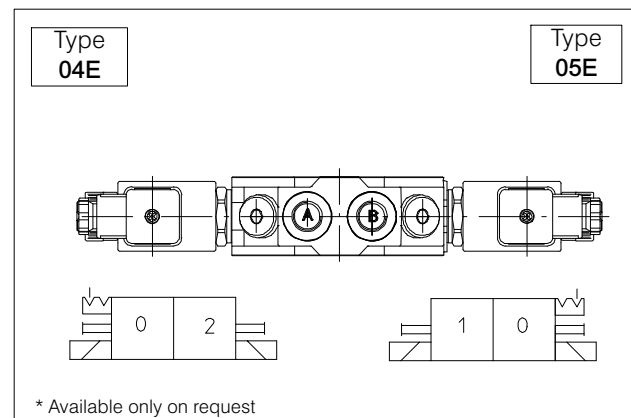

8B.8 4th Floating position

8B.8.1 Main features

Max operating pressure: 250 bar
 Max admitted flow: 35 l/min

Average leakage: 30 cm³/min (100 bar, 50°C, 27 mm²s⁻¹)
 Solenoid power: 48 Watt (12-24 Vdc)

8B.8.2 General specification

- Pressure drops with 35 lt/min:

Pos 0
 P ⇒ T 2 bar

Pos 1 and 2
 P ⇒ A / P ⇒ B 9 bar
 B ⇒ T / A ⇒ T 5.5 bar

Pos 3 (4th floating position)
 A ⇒ T / B ⇒ T 12.5 bar

- Parallel circuit, electric operated
- Compatible for assembling on HDS11 valve series
- Intermediate spacers 15 mm width needed

- In case the directional control valve consists of 2 or more sections, we suggest to position the section (or the sections) with 4th floating position as last section in the pack close to the "T" outlet cover.
- In the electric 4th floating position it is necessary to use always the cover with "T" side outlet (ex. P04, P05, etc.)
- To be used, if possible, in circuits without the carry-over version (on the contrary please contact our Sales Department)
- The 4th floating position must always be realized as from the "0" neutral position with both solenoids not energized.
- It is not possible to have versions with OA-C-UC valves with the 4th floating position section.

8B.8.3 Dimensional data

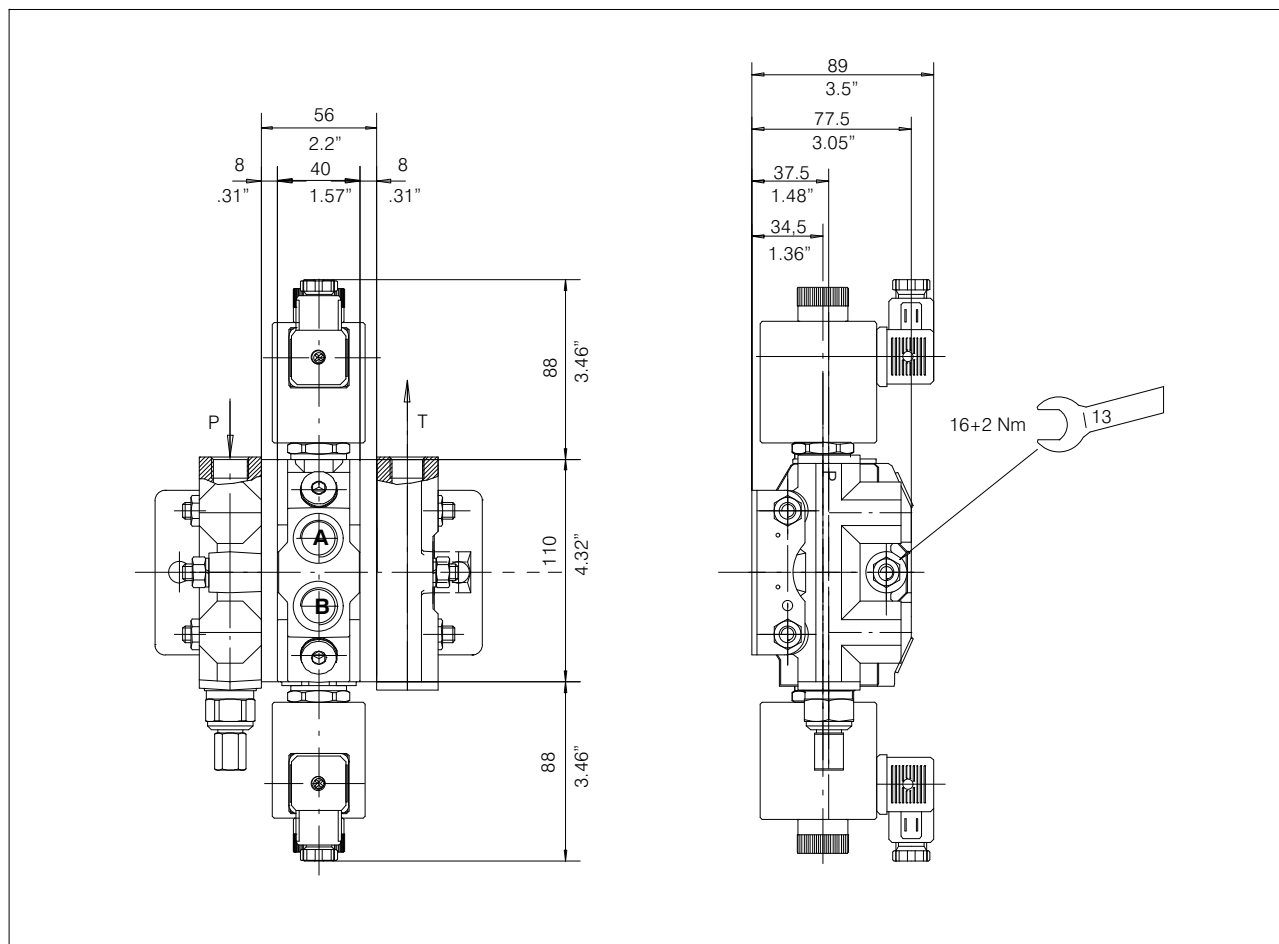

8B.8.4 Hydraulic circuit

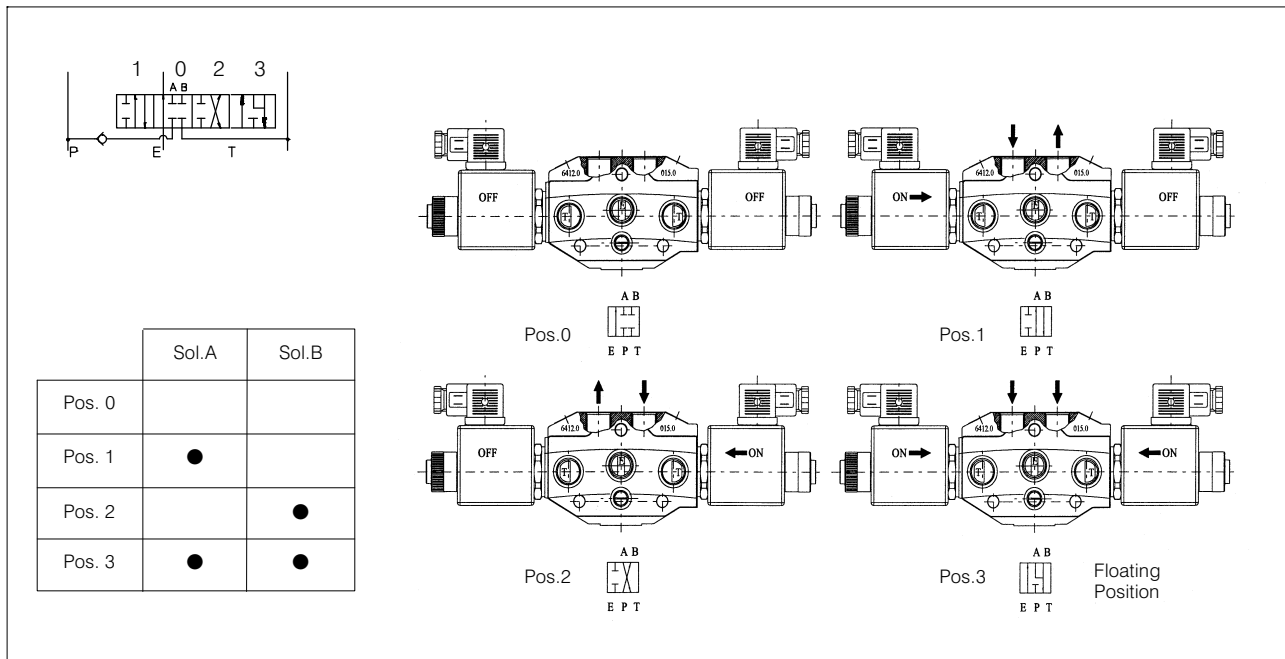

8B.8.5 Spool chart

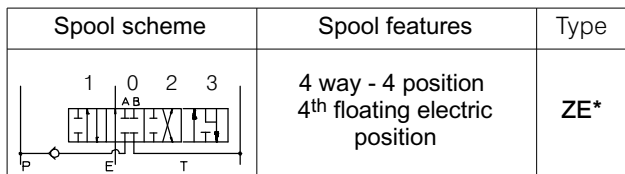

* Special body required

8B.8.6 Spool action

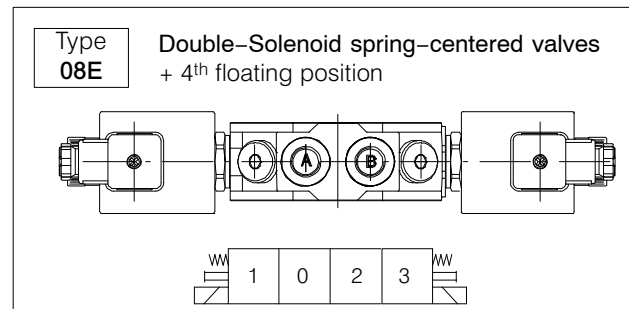

8B.8.7 Sectional body and manifold

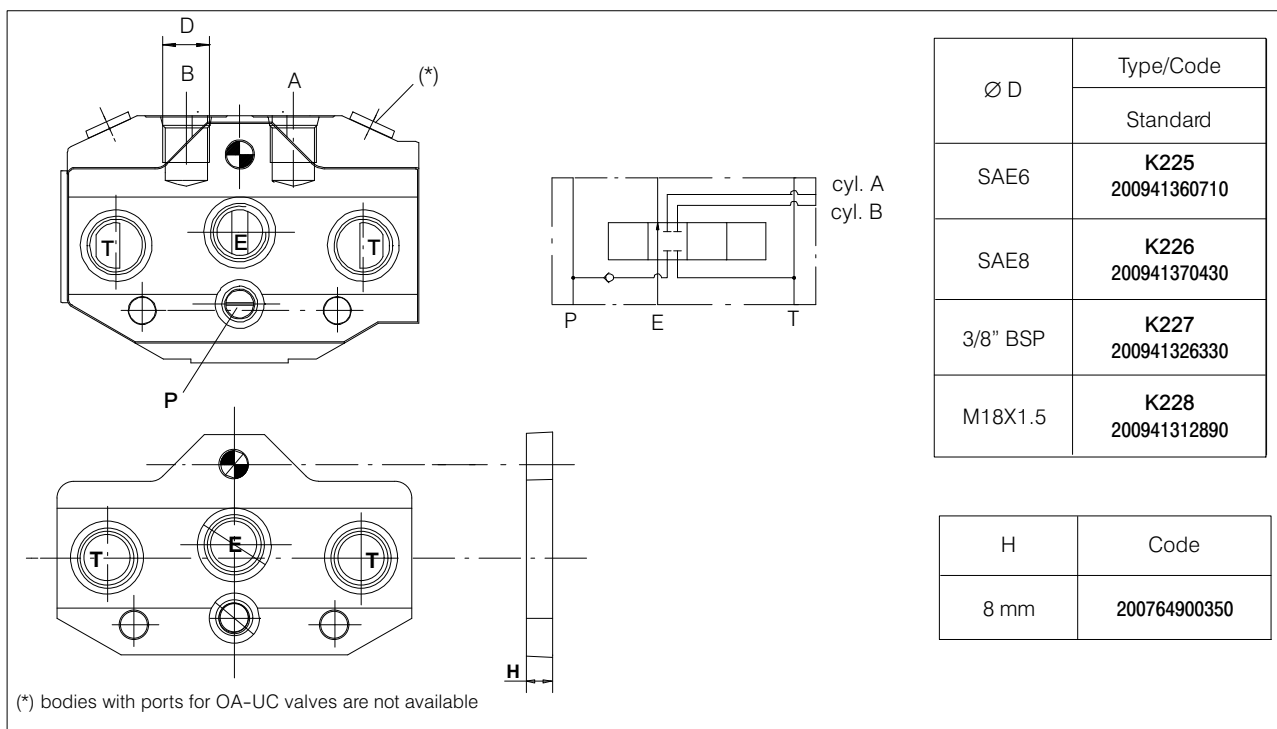

8B.9 Cartridge valves

8B.9.1 Flow control valve series VS

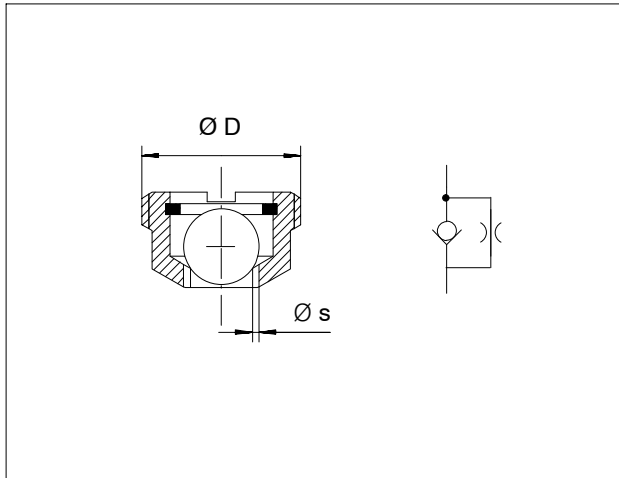

Ø D	Valve type	Code	Ø s
M18X1,5	VS4	200787200430	1.4
	VS6	200787200450	2
	VS11	200787200330	2.5
3/8" BSP	VS15	200787200370	1.4 (Ø 6.5)
	VS16	200787200380	1.4
	VS17	200787200390	1.4 (Ø 7.2)
	VS39	200787201660	2.5
SAE6	VS18	200787200400	1.5
	VS25	200787201040	2
	VS26	200787201050	2

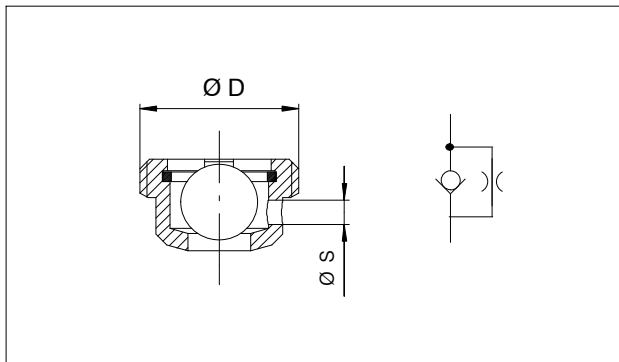

Ø D	Valve type	Code	Ø s
M18x1,5	VS105	200787201690	0.5
	VS108	200787201700	0.8
	VS112	200787201710	1.2
	VS116	200787201720	1.6
	VS125	200787201730	2.5
3/8" BSP	VS225	200787201740	2.5
SAE6	VS625	200787201750	2.5

8B.9.2 Piloted check valve

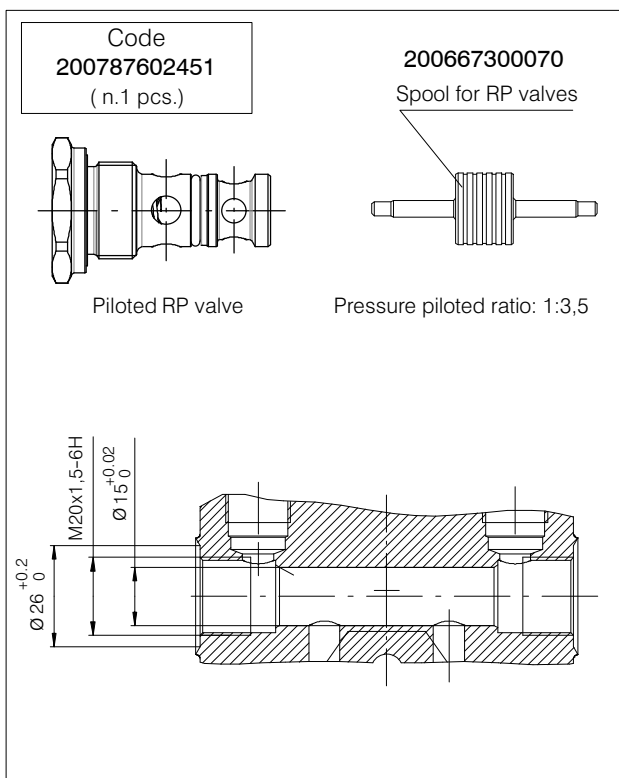

8B.10 Solenoid operated directional valve:

SP817/22-TVR

Normally closed - Pilot type

Poppet type, bi-directional flow admitted

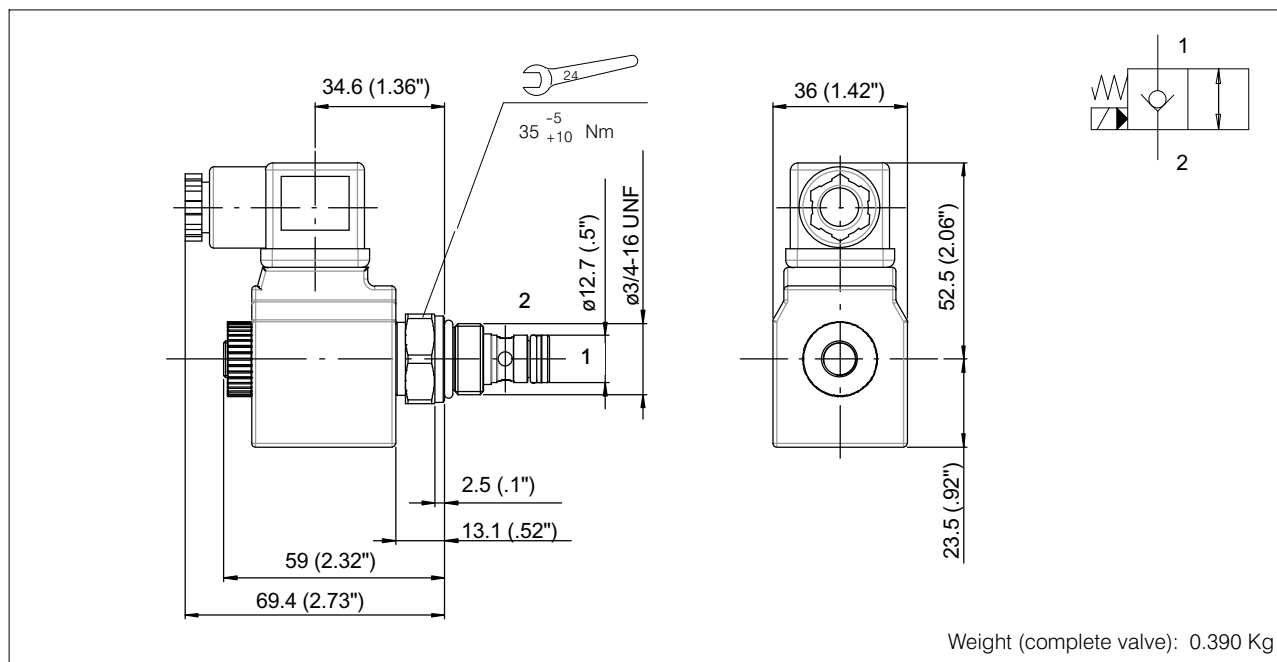

Directional valve without coil and connector

SP817/22-TVR P.M.	200757200750
Complete solenoid valve for D.C. current	
SP817/22-TVR/13-HC	200957010044
SP817/22-TVR/23-HC	200957020046

Coil voltage

	D.C.	
Volt	12 V.	24 V.
Type	13	23

Directional valve without coil and connector

Electric performances	
Max. pressure	300 bar
	4356 PSI
Max. flow	25 l/min.
	6.66 U.S.G.P.M.
Rated power	22 Watt
Intermittence	ED= 100%
Voltage tolerance	± 10%
Internal leakage	0-5 drops/min.
Temperature range	-20/+90° C
Connector type	DIN 43650
Time to open (50-210 bar)	15-100 ms.
Time to close (50-210 bar)	15-100 ms.
O-Ring replacement kit	200974200140

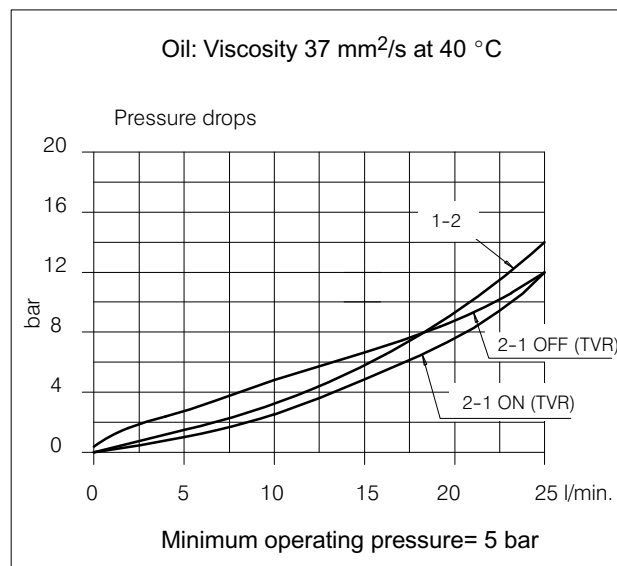

8C Elements with pressure and flow control PQ

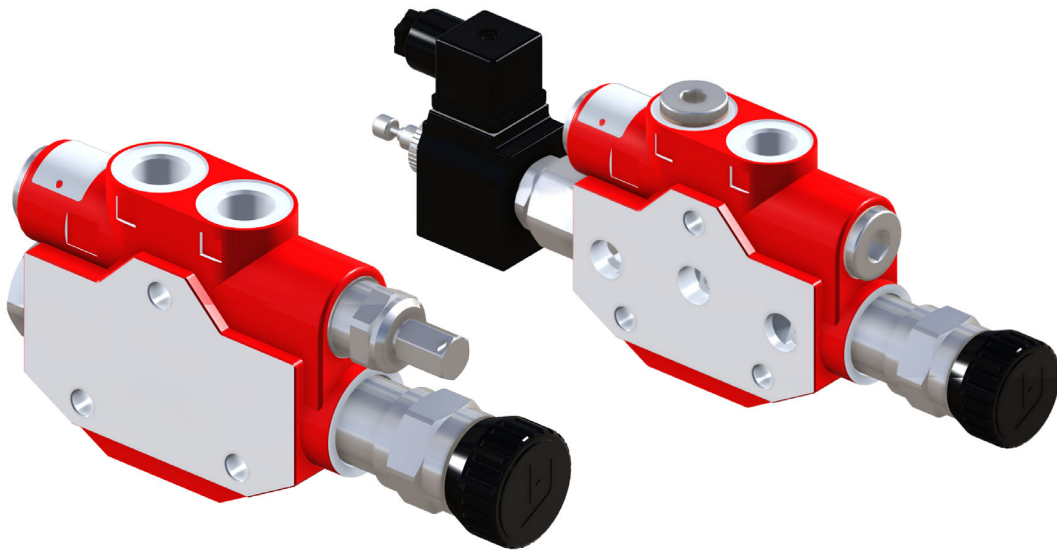

Contents

8C.1	General specification	135
8C.2	Sectional body K100	136
8C.3	Inlet cover T100	137
8C.4	Sectional body K88	138
8C.5	Inlet cover T88	139
8C.6	Sectional body K90	140
8C.7	Inlet cover T90	141
8C.8	Inlet cover T89	142
8C.9	Proportional flow control PFCR11	143
8C.10	Special sectional bodies	144
8C.11	End cover for K100 and T100	145
8C.12	By-pass solenoid valve -BP3-	146

8C.1 General specifications

Max continuous operating pressure supply port P	250 bar	Control accuracy	VDP 40 = 0 to 40 l/min
Max intermittent peak pressure work port A/B	320 bar	Pressure difference Δp	$\pm 5\%$
Max back pressure tank port T	30 bar	Oil temperature range	max. 6 bar
Nominal flow	max. 50 l/min	Viscosity range	-10° to +80° C
		Recommended filtration	16 to 75 mm ² /sec
			≤ 25 micron
Adjustable setting flow range on 350° turning-knob:		Adjustable direct acting:	
Min flow	0 l/min	Relief valve on the lines	Inlet flow: RV1
Max flow (input)	40 l/min		Priority flow: RV2
			Residual flow: RV3
Fixed priority flow	VDPF = 0 to 40 l/min	By-pass solenoid valve	BP3/AE
Adjustable priority flow	VDP 06 = 0 to 6 l/min		BP3/CE
	VDP 12 = 0 to 12 l/min		
	VDP 25 = 0 to 25 l/min		

8C.2 Sectional body K100

8C.2.1 Application variation

Intermediate section with priority flow divider pressure compensated valve, pressure relief valves and by-pass valve.

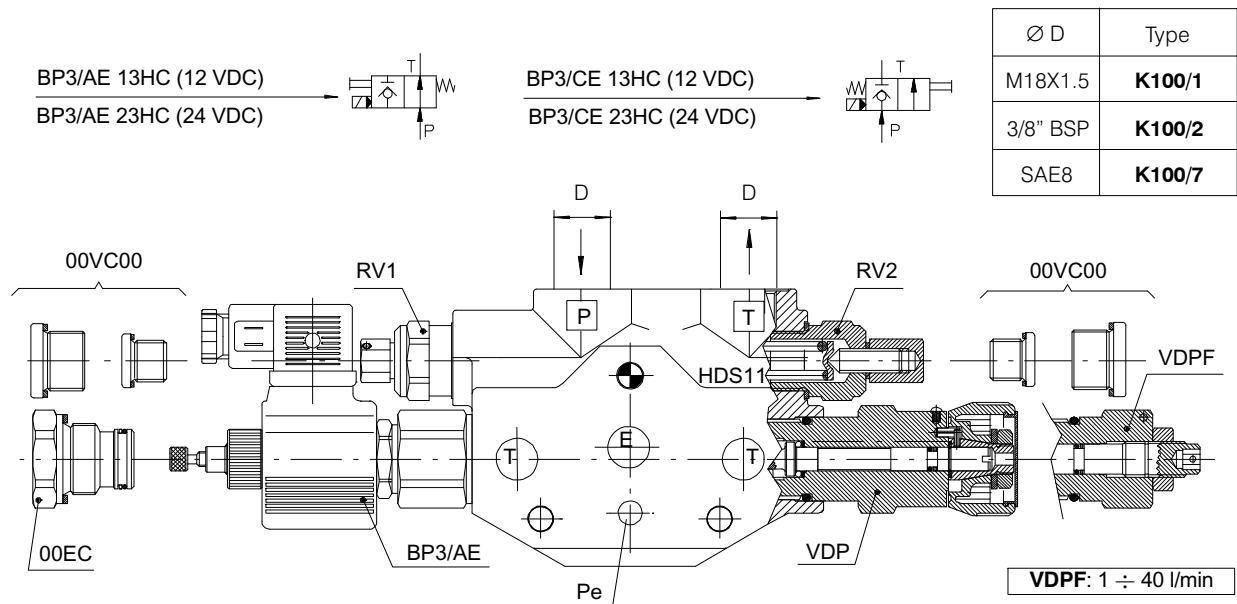

Pressure set range (bar)	Standard Setting bar	Relief valves Type
30 ÷ 95	60	RV1 or RV2 - 06
96 ÷ 210	150	RV1 or RV2 - 15
211 ÷ 320	260	RV1 or RV2 - 26

Flow set range (l/min)	Standard Setting l/min	Flow regulator Type
0 ÷ 6	6	VDP 06
0 ÷ 12	12	VDP 12
0 ÷ 25	25	VDP 25
0 ÷ 40	40	VDP 40

8C.2.2 Scheme example

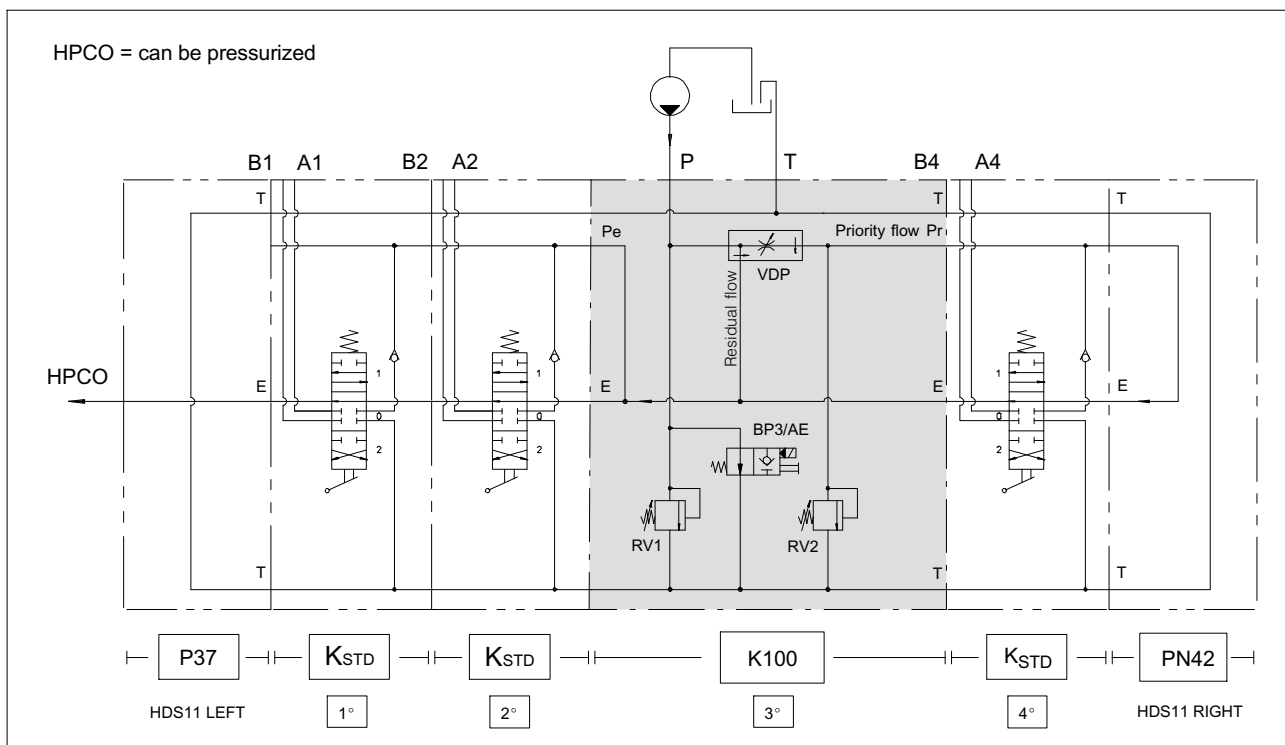

8C.3 Inlet cover T100

8C.3.1 Application variation

Inlet cover with priority flow divider pressure compensated valve, pressure relief valves and by-pass valve.

BP3/AE 13HC (12 VDC)
BP3/AE 23HC (24 VDC)

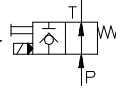

BP3/CE 13HC (12 VDC)
BP3/CE 23HC (24 VDC)

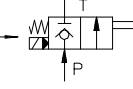

Ø D	Type
M18X1.5	T100/1
3/8" BSP	T100/2
SAE8	T100/7

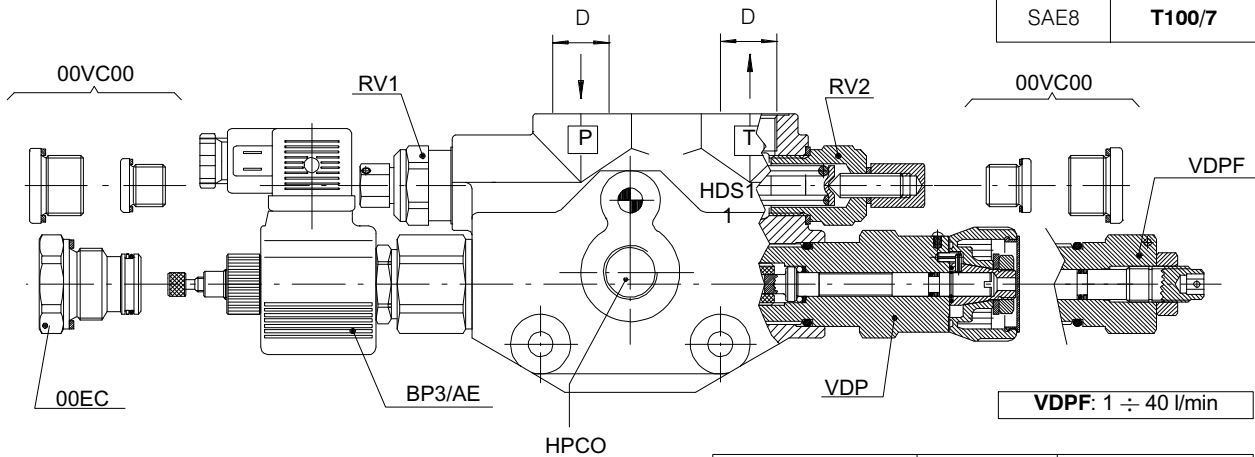

VDPF: 1 ÷ 40 l/min

Pressure set range (bar)	Standard Setting bar	Relief valves Type
30 ÷ 95	60	RV1 or RV2 - 06
96 ÷ 210	150	RV1 or RV2 - 15
211 ÷ 320	260	RV1 or RV2 - 26

Pressure set range (l/min)	Standard Setting l/min	Flow regulator Type
0.5 ÷ 6	6	VDP 06
0.5 ÷ 12	12	VDP 12
0.5 ÷ 25	25	VDP 25
0.5 ÷ 40	40	VDP 40

8C.3.2 Scheme example

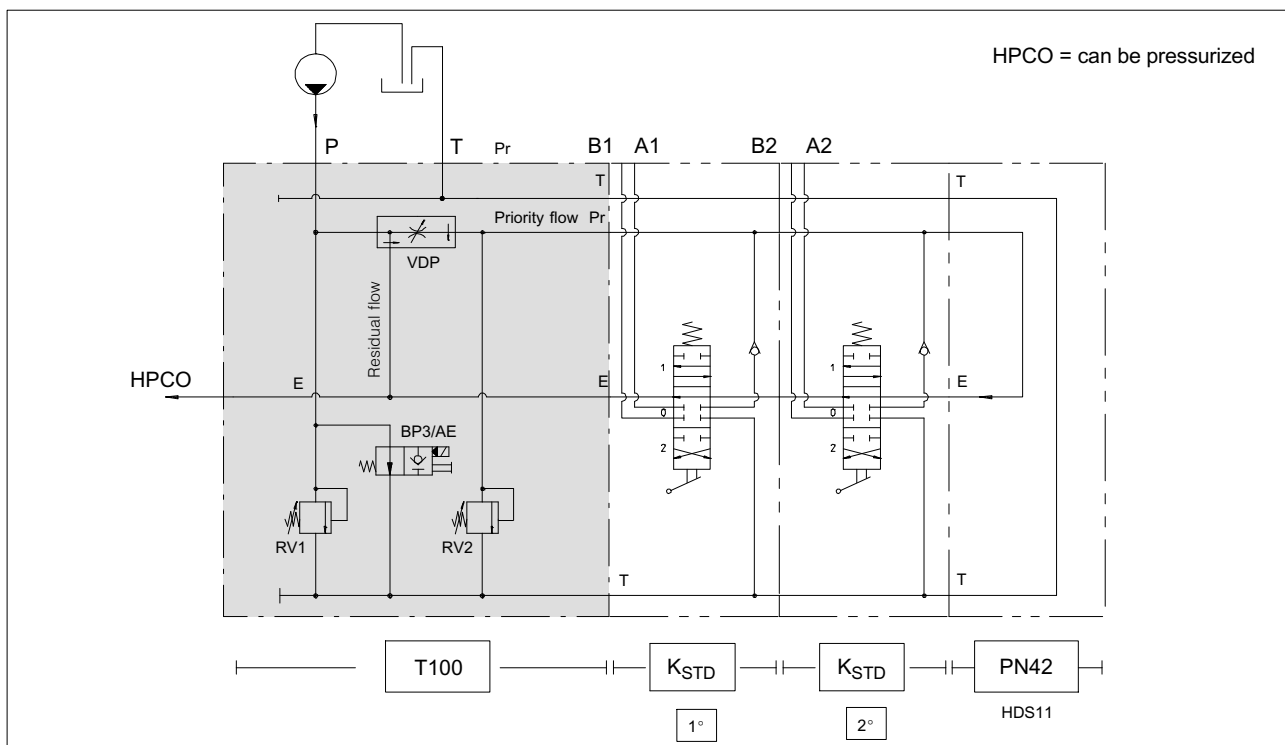

8C.4 Sectional body K88

8C.4.1 Application variation

Intermediate section with priority flow divider pressure compensated valve, pressure relief valves and by-pass valve.

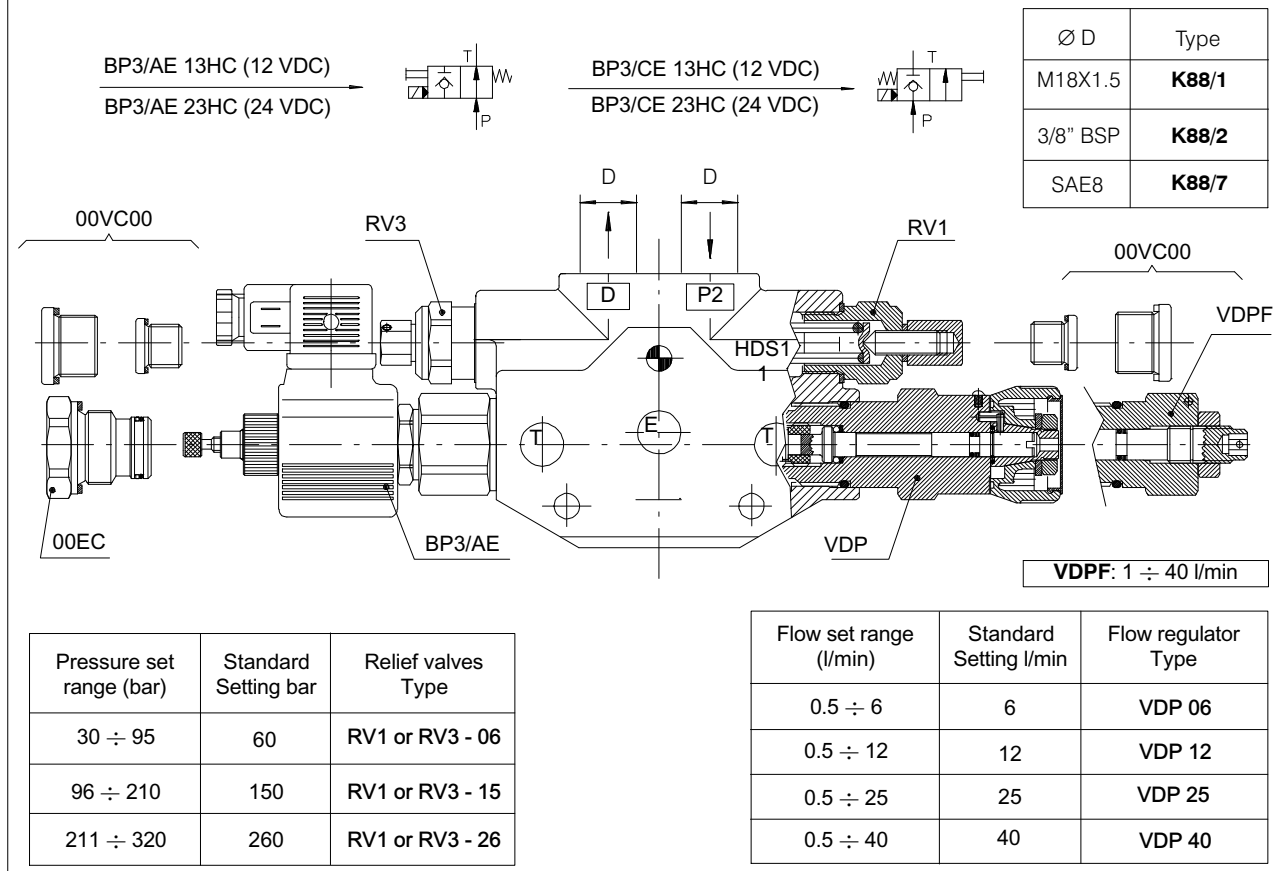

8C.4.2 Scheme example

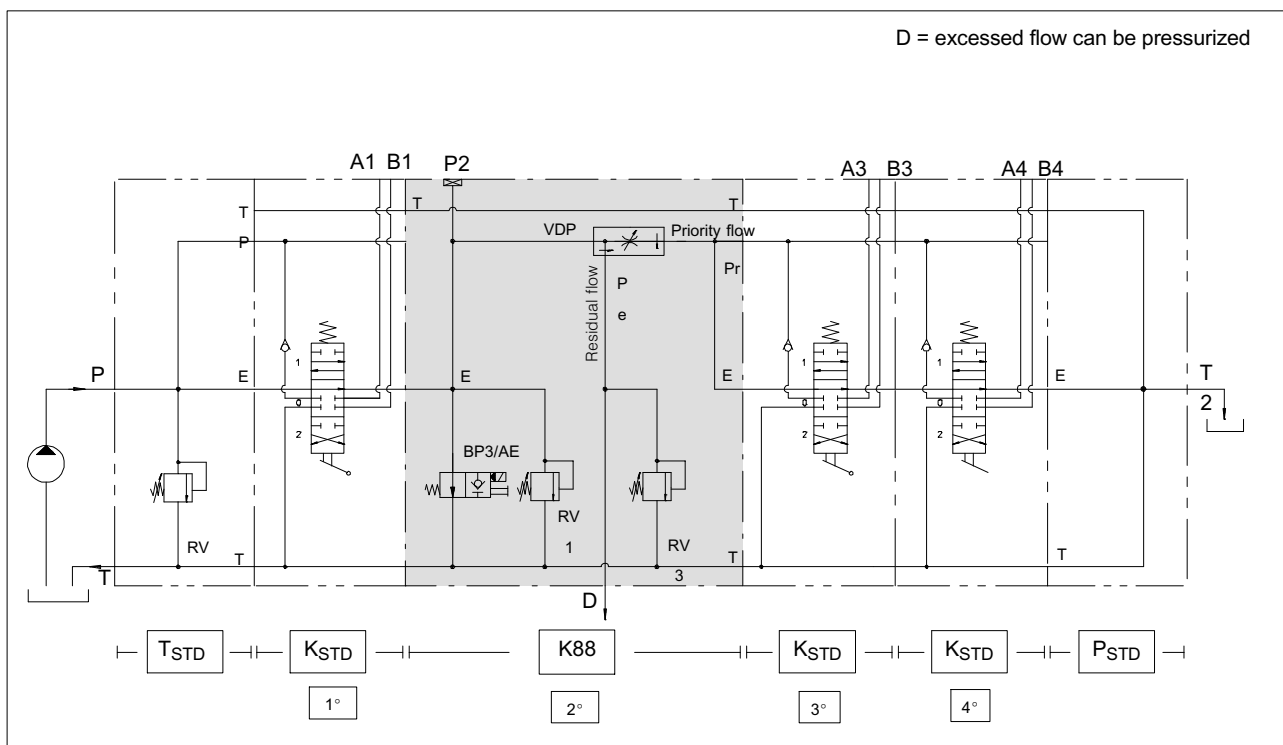

8C.5 Inlet cover T88

8C.5.1 Application variation

Inlet cover with priority flow divider pressure compensated valve, pressure relief valves and by-pass valve.

BP3/AE 13HC (12 VDC)
BP3/AE 23HC (24 VDC)

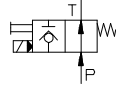

BP3/CE 13HC (12 VDC)
BP3/CE 23HC (24 VDC)

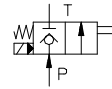

Ø D	Type
M18X1.5	T88/1
3/8" BSP	T88/2
SAE8	T88/7

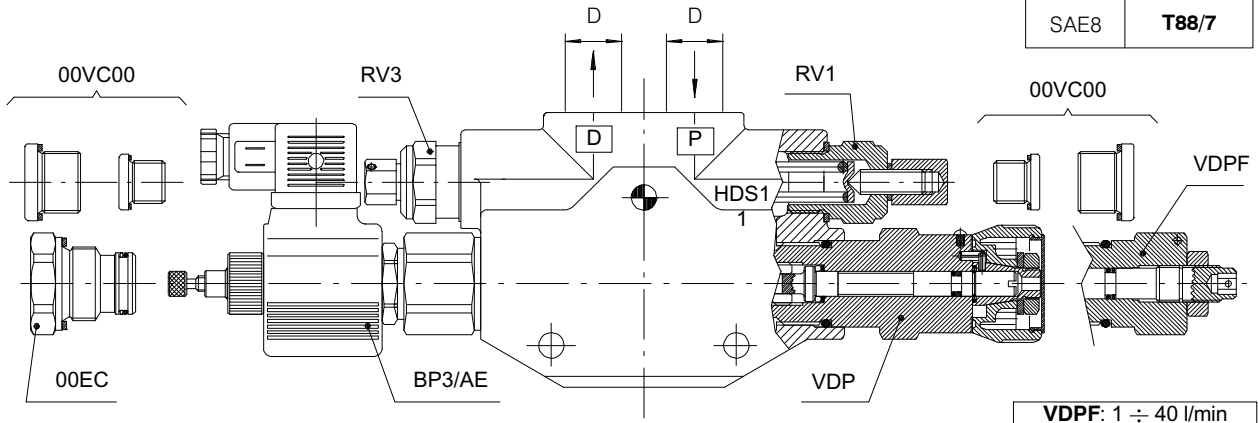

VDPF: 1 ÷ 40 l/min

Pressure set range (bar)	Standard Setting bar	Relief valves Type
30 ÷ 95	60	RV1 or RV3 - 06
96 ÷ 210	150	RV1 or RV3 - 15
211 ÷ 320	260	RV1 or RV3 - 26

Flow set range (l/min)	Standard Setting l/min	Flow regulator Type
0.5 ÷ 6	6	VDP 06
0.5 ÷ 12	12	VDP 12
0.5 ÷ 25	25	VDP 25
0.5 ÷ 40	40	VDP 40

8C.5.2 Scheme example

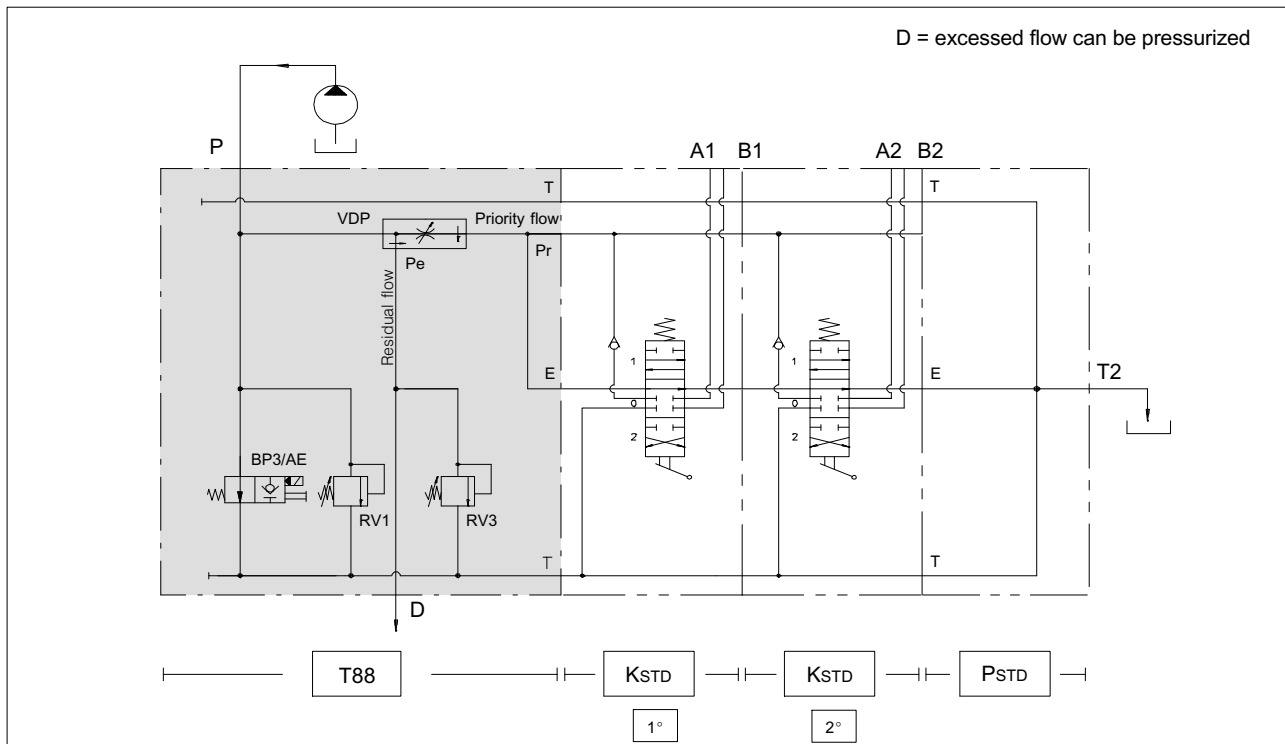

8C.6 Sectional body K90

8C.6.1 Application variation

Intermediate section with priority flow divider pressure compensated valve, pressure relief valves and by-pass valve.
Excess flow to tank.

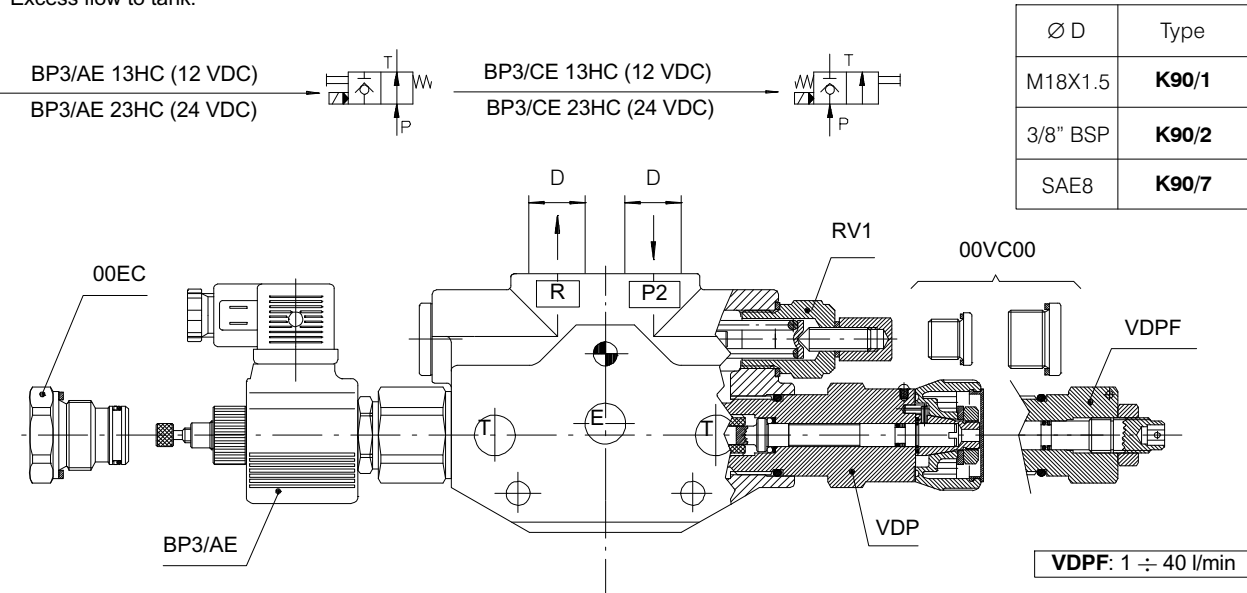

Pressure set range (bar)	Standard Setting bar	Relief valves Type
30 ÷ 95	60	RV1 - 06
96 ÷ 210	150	RV1 - 15
211 ÷ 320	260	RV1 - 26

Flow set range (l/min)	Standard Setting l/min	Flow regulator Type
0.5 ÷ 6	6	VDP 06
0.5 ÷ 12	12	VDP 12
0.5 ÷ 25	25	VDP 25
0.5 ÷ 40	40	VDP 40

8C.6.2 Scheme example

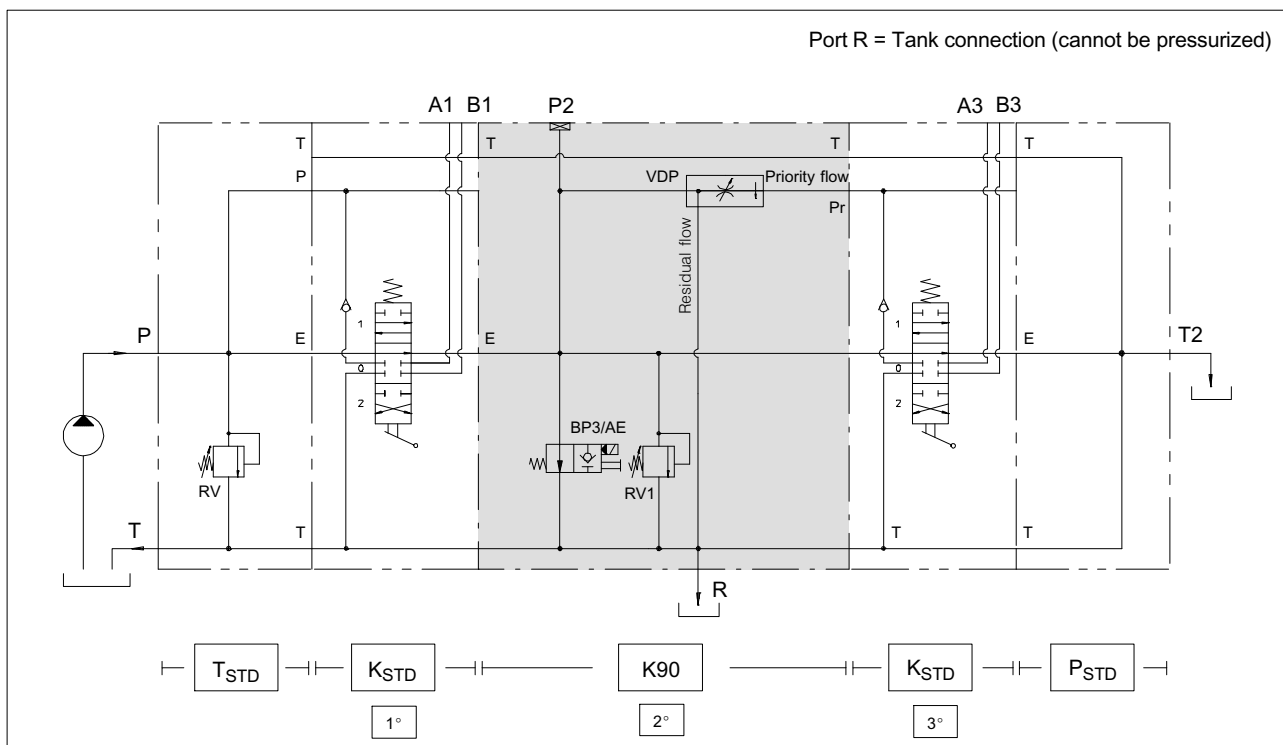

8C.7 Inlet cover T90

8C.7.1 Application variation

Inlet cover with priority flow divider pressure compensated valve, pressure relief valves and by-pass valve. Excess flow to tank.

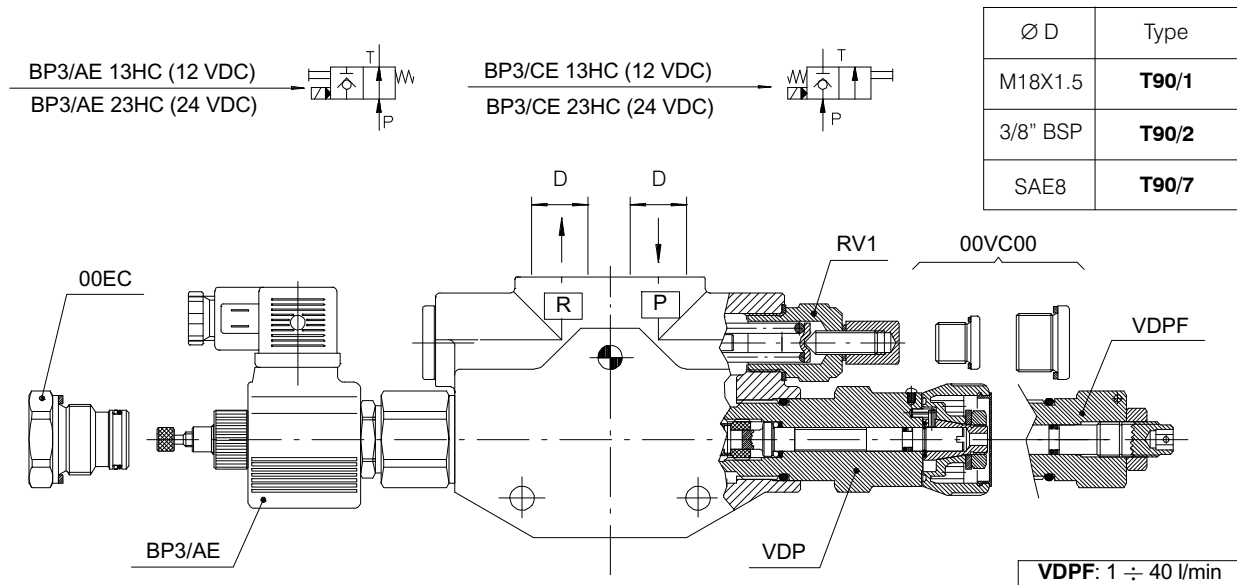

Pressure set range (bar)	Standard Setting bar	Relief valves Type
30 ÷ 95	60	RV1 - 06
96 ÷ 210	150	RV1 - 15
211 ÷ 320	260	RV1 - 26

Flow set range (l/min)	Standard Setting l/min	Flow regulator Type
0.5 ÷ 6	6	VDP 06
0.5 ÷ 12	12	VDP 12
0.5 ÷ 25	25	VDP 25
0.5 ÷ 40	40	VDP 40

8C.7.2 Scheme example

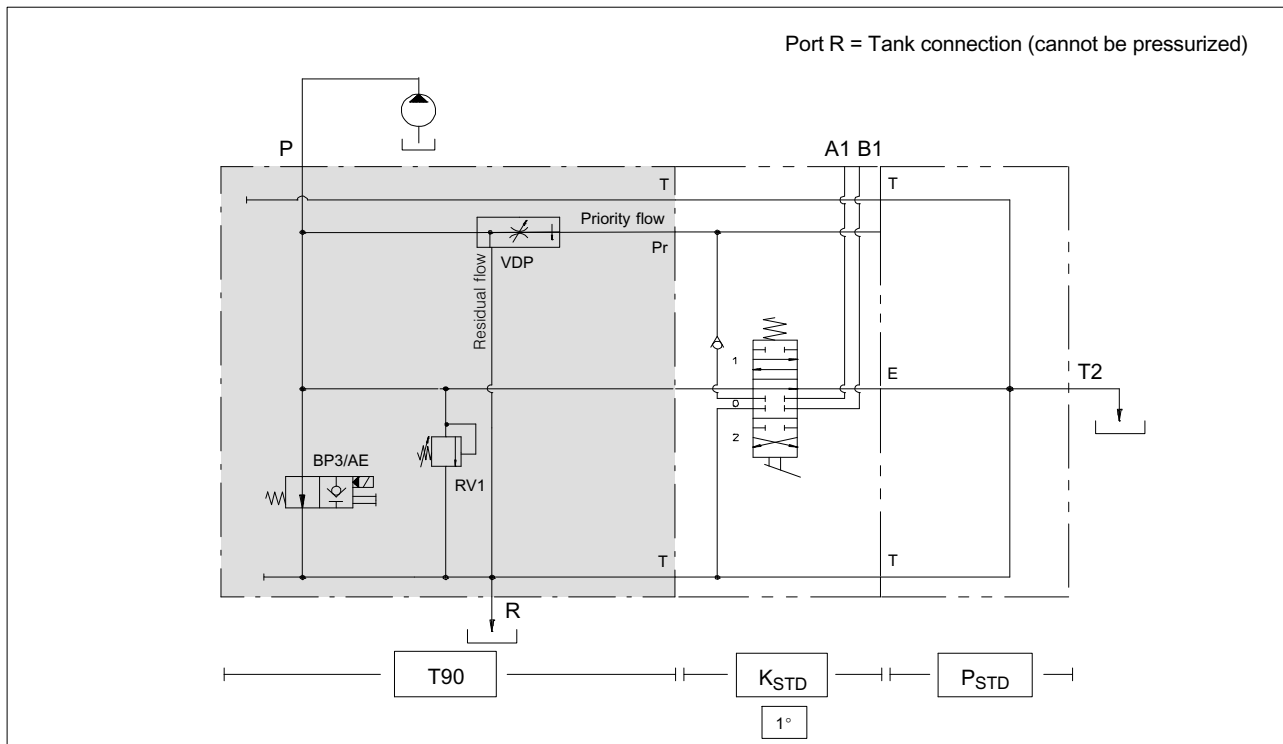

8C.8 Inlet cover T89*

8C.8.1 Application variation

Inlet cover with priority flow divider pressure compensated valve, pressure relief valves and by-pass valve.

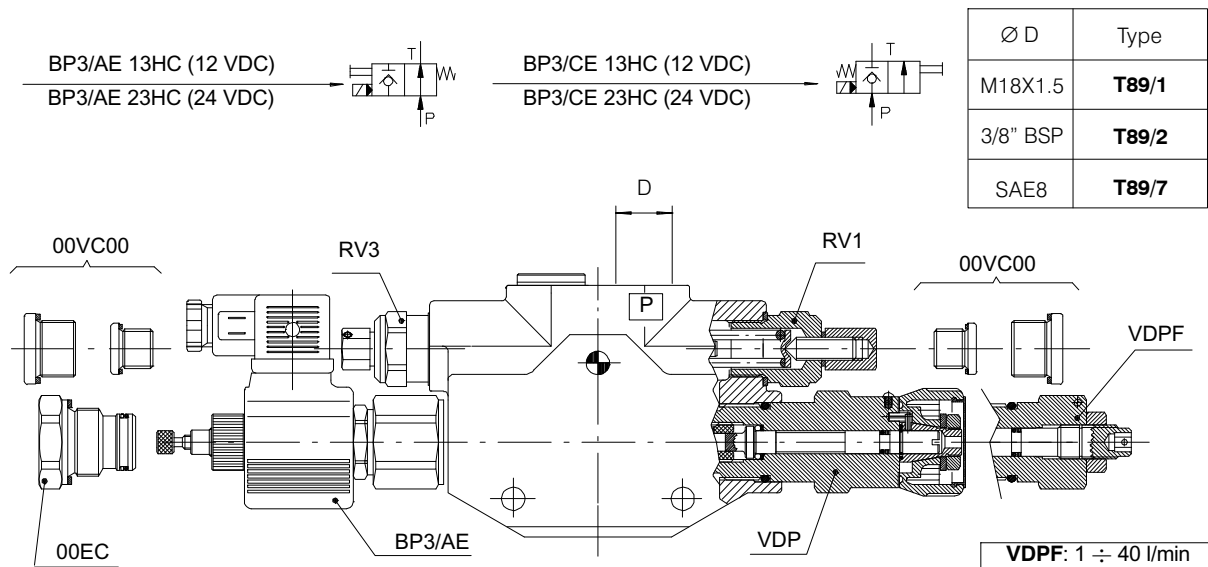

Pressure set range (bar)	Standard Setting bar	Relief valves Type
30 ÷ 95	60	RV1 or RV3 - 06
96 ÷ 210	150	RV1 or RV3 - 15
211 ÷ 320	260	RV1 or RV3 - 26

Flow set range (l/min)	Standard Setting l/min	Flow regulator Type
0.5 ÷ 6	6	VDP 06
0.5 ÷ 12	12	VDP 12
0.5 ÷ 25	25	VDP 25
0.5 ÷ 40	40 </td <td>VDP 40</td>	VDP 40

8C.8.2 Scheme example

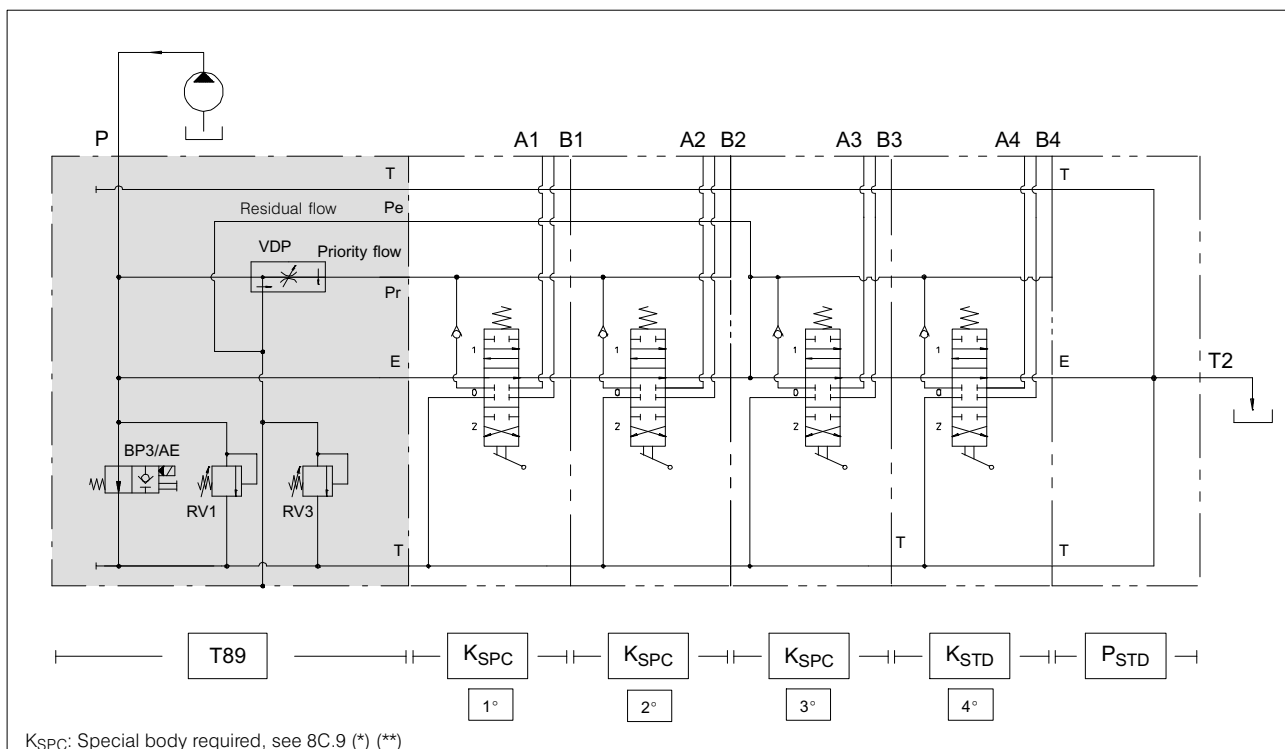

8C.9 Special sectional bodies

8C.9.1 Special element (priority flow): to be used only with T89 (*) inlet cover

Ø D	Type/Code	
	Standard	Section with valve UC - OA - C
SAE6	K111 200941360640	K27 200941360560
SAE8	K112 200941370380	K24 200941370370
3/8" BSP	K113 200941320410	K58 200941320400
M18X1.5	K114 200941310330	K59 200941310320

8C.9.2 Special element (residual flow): to be used only with T89 (**) inlet cover

Ø D	Type/Code	
	Standard	Section with valve UC - OA - C
SAE6	K116 200941360630	K81 200941360590
SAE8	K117 200941370360	K82 200941370350
3/8" BSP	K118 200941320390	
M18X1.5	K119 200941310310	K86 200941310300

Note: Body code consist of machined casting, seals and hold check valve only. Not to be used for complete valve order.

8C.10 Proportional flow control PFCR11

8C.10.1 Example of application on K100 body

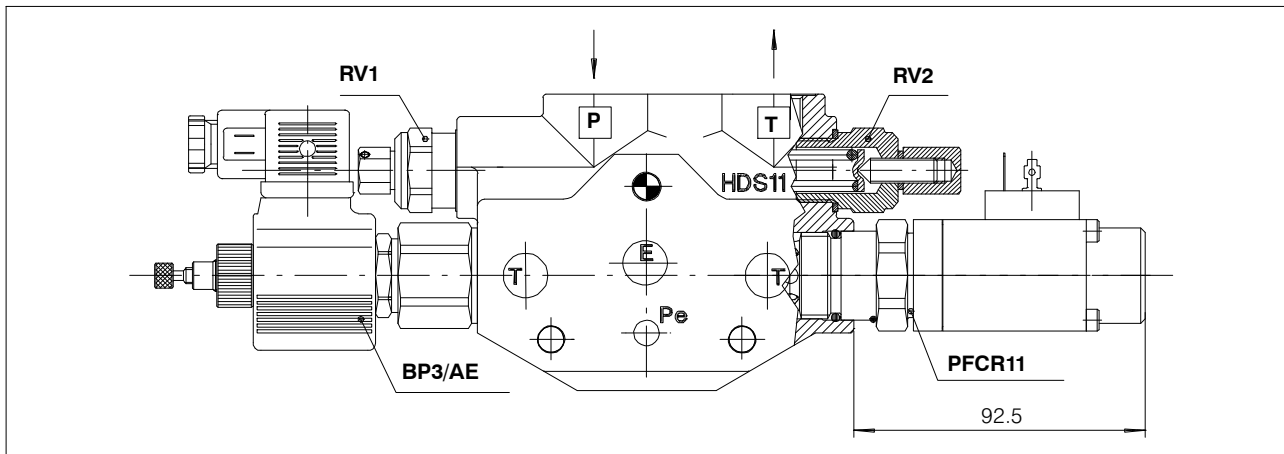

8C.10.2 Example of hydraulic scheme K100

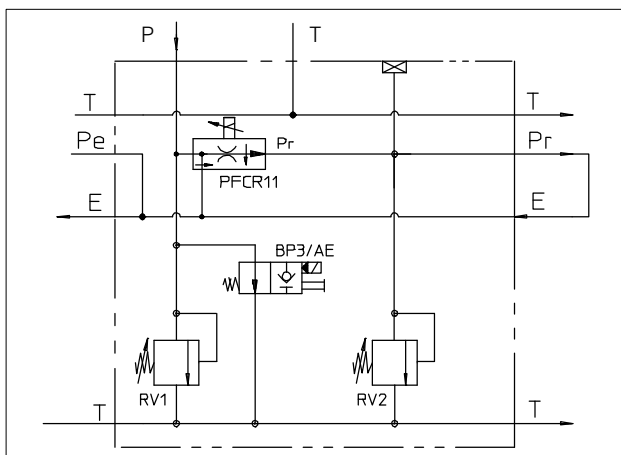

8C.10.3 Electric performances

Coil according to	VDE 0580	
Connector type	DIN 43650	
Duty rating	ED= 100%	
Suggested dither	0-150 Hertz (*)	
Insulation class	IP54 (DIN 40050) without connector	
	IP65 (DIN 40050) with connector	
Coil winding class	F	
Voltage ±5%	12 V (DC)	24 V (DC)
Max current	2.25 A.	1.08 A.
Resistance at 20°C	2.8 Ohm	12.7 Ohm
Nominal power	17.2 Watt	17.4Watt
Insurance	90 mH	406 mH
	armature falling down	armature rising

8C.10.4 Code

Flow l/min	Voltage	Type	Code**
14	12 V	PFCR11/V2-14-P2-13	200788000110
14	24 V	PFCR11/V2-14-P2-23	200788000120
35	12 V	PFCR11/V8-35-P2-13	200788000070
35	24 V	PFCR11/V8-35-P2-23	200788000080

8C.10.5 Hydraulic performances

Max. pressure	270 bar
Max. recommended pressure	230 bar
Regulated flow range	0.5 - 14 l/min
	0.5 - 35 l/min
Temperature range	-5/+70° C

8C.10.6 Current/flow regulated diagram

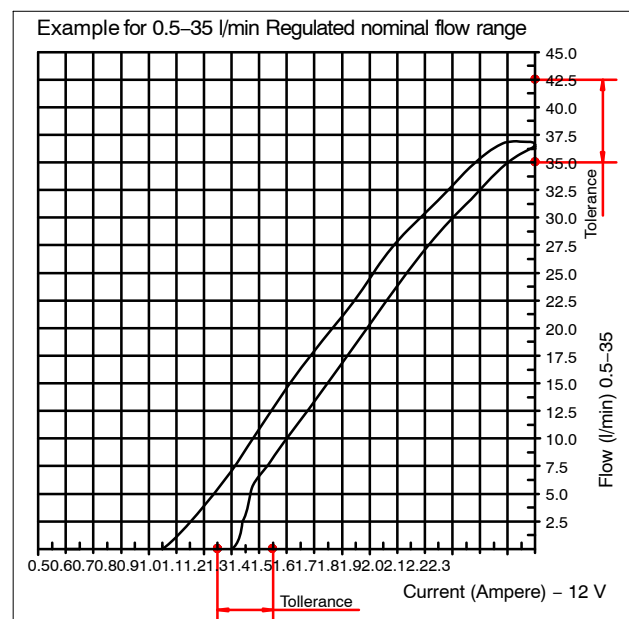

Performances obtained in 60+60 seconds under the following conditions:
 12 VDC Proportional Coil
 Pressure on priority flow channel: 100 bar
 No pressure on the residual flow channel:
 Minimum current: 0 Amp. -Maximum current: 2.3 Amp.
 Inlet flow: 56 l/min
 Ramp UP: 0 sec - Ramp DOWN: 0 sec
 Oil temp: 50° C - Oil viscosity: 32 mm²/s at 40° C

(* frequency could affect the valve seal)
 (**code without connector)

8C.11 End cover for K100 and T100

8C.11.1 Right cover

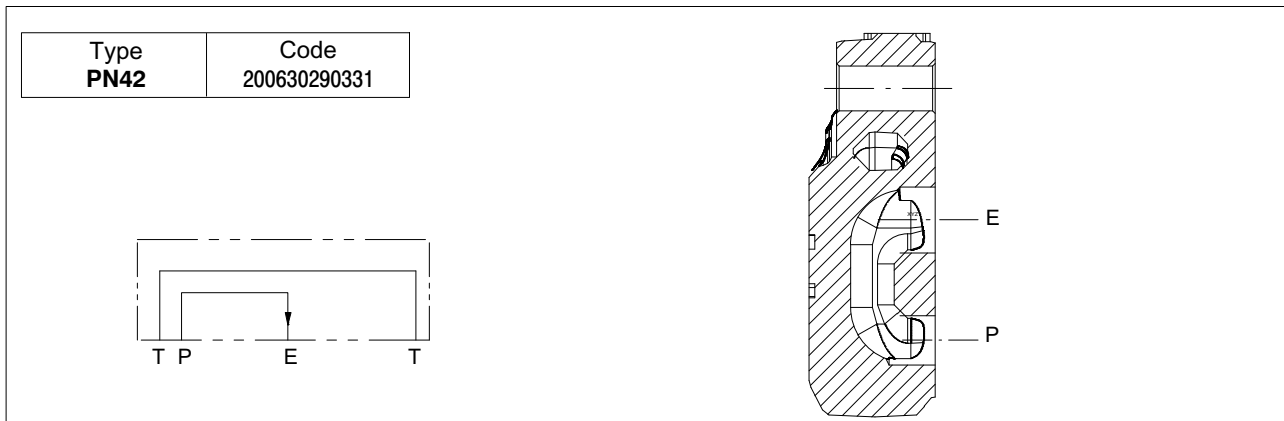

8C.11.2 Standard left cover

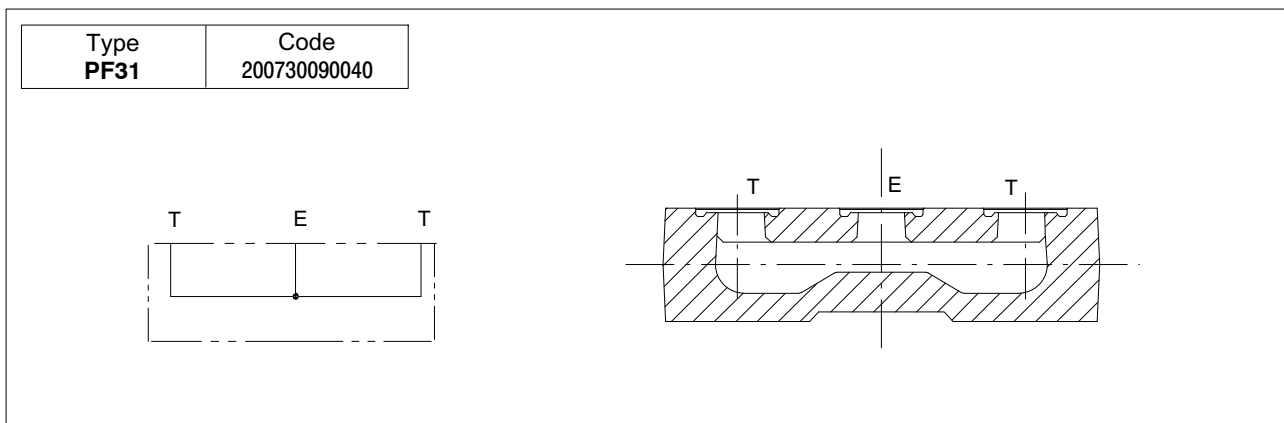

8C.11.3 Carry-over left cover

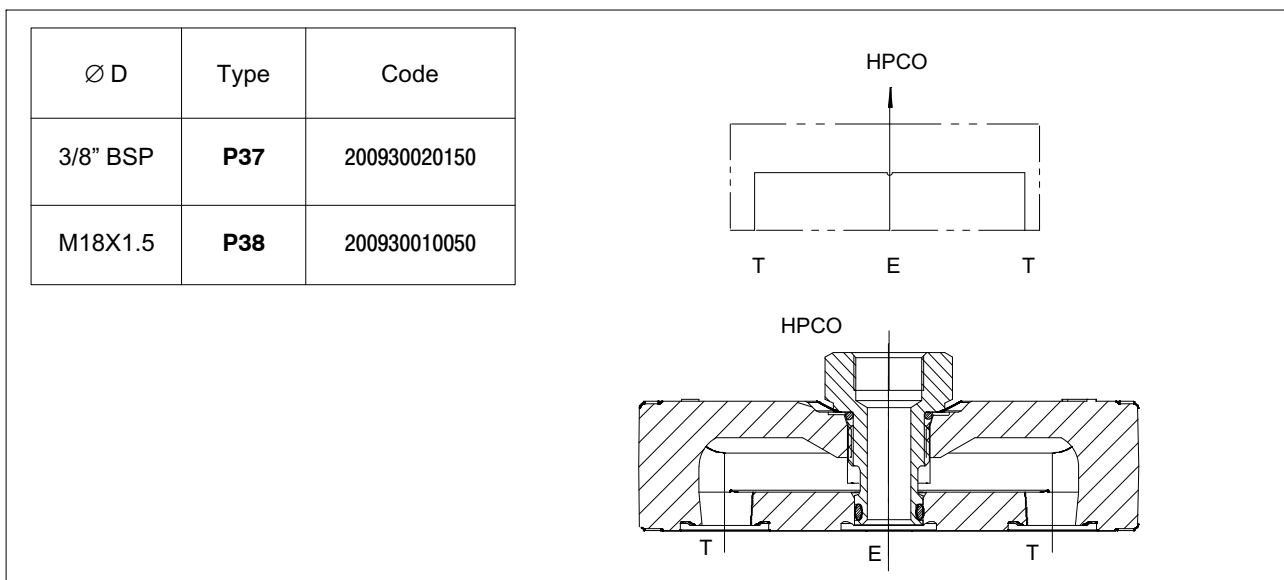

8C.12 By-Pass solenoid valve - BP3 -

8C.12.1 Normally closed with manual override

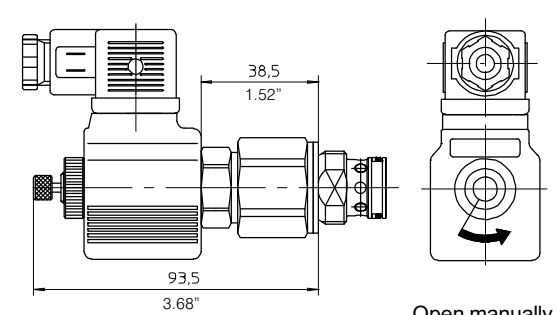

Voltage	Type	Code
without coil	BP3/CE HDS11PQ p.m.	200757200480
12 V. D.C.	BP3/CE 13-HC27 HDS11PQ	200957010074
24 V. D.C.	BP3/CE 23-HC27 HDS11PQ	200957020071

8C.12.2 Normally open with manual override

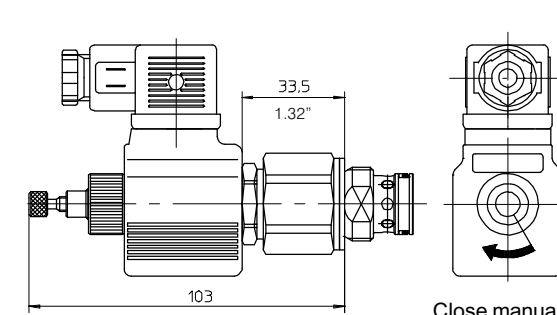

Voltage	Type	Code
without coil	BP3/AE HDS11PQ p.m.	200757200490
12 V. D.C.	BP3/AE 13-HC27 HDS11PQ	200957010083
24 V. D.C.	BP3/AE 23-HC27 HDS11PQ	200957020072

8C.12.3 Dimension

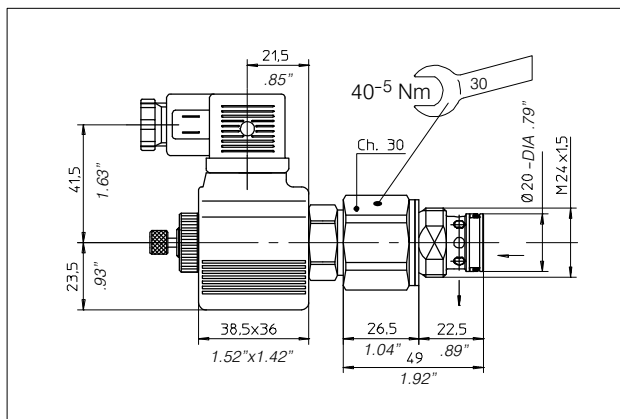

8C.12.4 BP3 Solenoid valve performances

Max. pressure	315 bar
Max. flow	60 l/min
Power	27 Watt
Intermittence	ED 100%
Voltage tolerance	± 10%
Temperature range	-20/+80 °C
Oil filtration	≤ 25 micron
Pressure drop Q= 30 l/min	7.5 bar
Pressure drop Q= 50 l/min	12.7 bar

8C.12.5 Spare parts

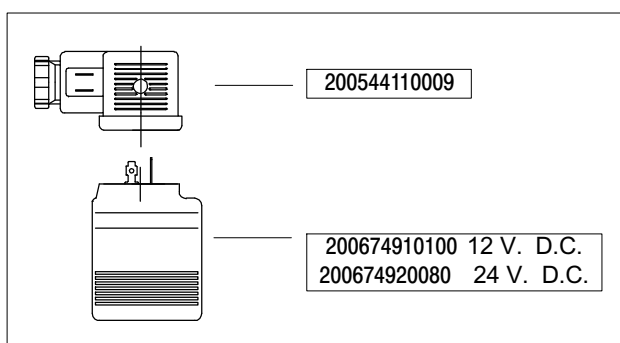

8C.12.6 Coil specifications

Voltage	12	24	V. D.C.
Power	27.2	27	Watt
Resistance (Ambient Temp.)	5.3	21.3	Ohm
Resistance (Stabilized Temp.)	8	32	Ohm
Current (Ambient Temp.)	2.2	1.12	Ampere
Current (Stabilized Temp.)	1.5	0.75	Ampere

info.it@bucherhydraulics.com

www.bucherhydraulics.com

© 2022 by Bucher Hydraulics S.p.A., IT - 42124 Reggio Emilia.

All rights reserved.

Data is provided for the purpose of product description only, and must not be considered as warranted characteristics in the legal sense. The information does not relieve users from the duty of conducting their own evaluations and tests. Because the products are subject to continual improvement, we reserve the right to amend the product specifications contained in this catalogue.

Classification: 430.300.000