

Differential Lock Valve

Series MT..DVD (for 3 motors)

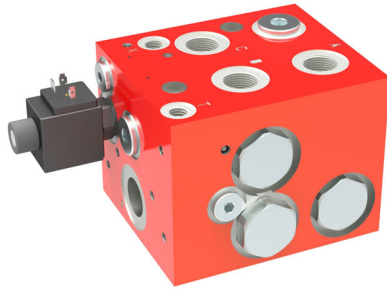

- robust and reliable
- energy-optimised over the whole flow range
- simple control
- compact design offers space-saving installation
- reliable, uniform motion of the wheel-drives being controlled



OIL SOLUTIONS

PO Box 38
Strathfieldsaye, VIC, 3551
1800 OIL SOL
1800 645 765

sales@oilsolutions.com.au

www.oilsolutions.com.au

"For All Your Hydraulic Needs"

1 Description

1.1 General

The differential lock valve consists essentially of two bi-directional flow dividers (dividing and combining) and a directional valve for optionally bypassing the flow dividers. It is intended for use in either open- or closed-loop hydrostatic drives with parallel-connected hydraulic motors. When the lock valve is switched OFF, the inlet flow can divide itself among the motors in any required manner. When the lock valve is switched ON, however, the inlet flow is divided into three pressure compensated portions in accordance with the division ratio of the lock valve. The motors are

thus driven at fixed speeds, regardless of their respective loads. This arrangement prevents any hydraulic wheel motor from spinning in conditions of poor traction. Two balancing orifices can optionally be arranged between the outlets A, B and C. These allow some redistribution of flow and prevent unwanted torque build-up between wheels in these circumstances, and when turning.

The differential lock valves can be supplied with either hydraulic, or electro-hydraulic, actuation.

1.2 Application examples

- Forklifts
- Sweepers

2 Symbols

2.1 Hydraulic actuation

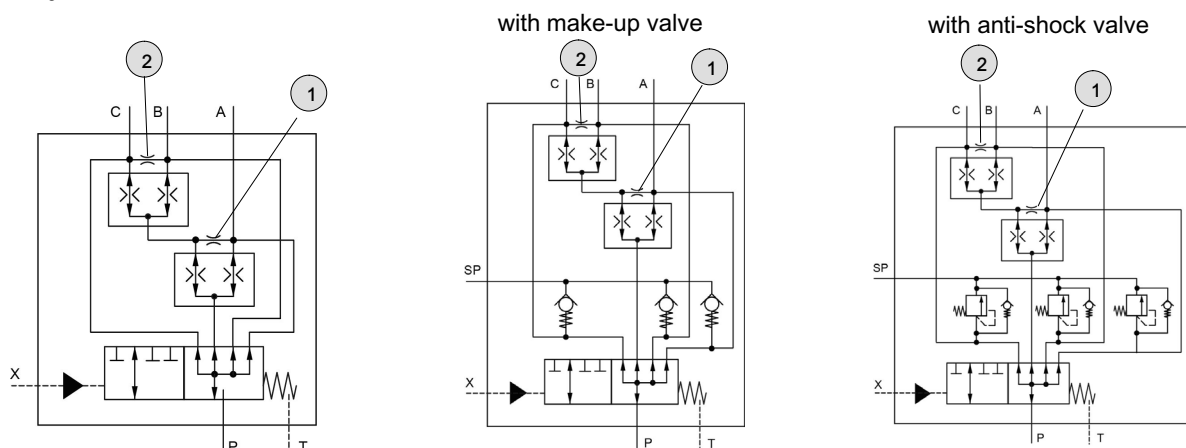

1 Balancing orifice D1 can be fitted

2 Balancing orifice D2 can be fitted

2.2 Electrohydraulic actuation

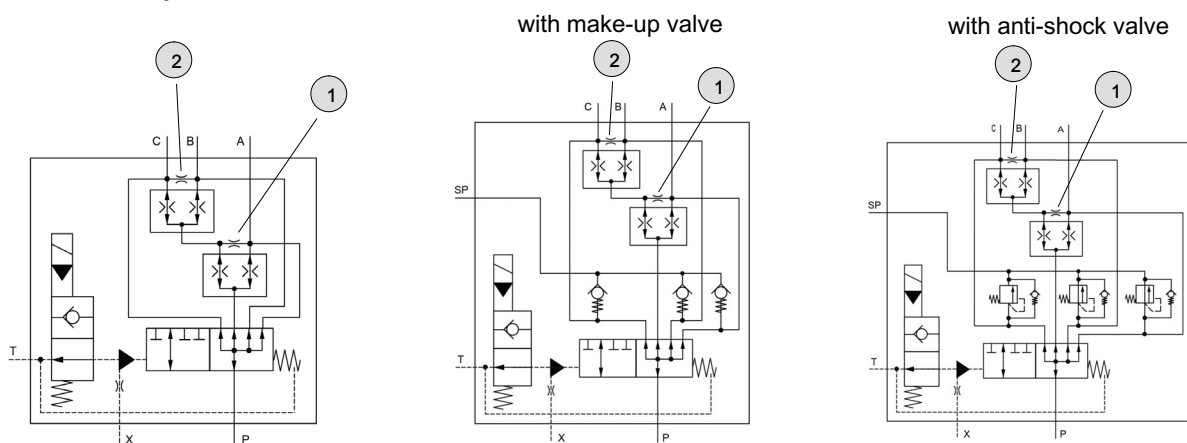

1	Balancing orifice D1 can be fitted	2	Balancing orifice D2 can be fitted
---	------------------------------------	---	------------------------------------

3 Technical data

Hydraulic characteristics	Unit	Description, Value	
		Size 08	Size 16
Nominal flow rate Q_{max}	l/min	100	250
Flow range ^{1) 2)}	l/min	25, 50, 75, 100	120, 160, 200, 250
Operating pressure p_{max}	bar	420	
Pilot pressure $p_p \text{ min.} - p_p \text{ max.}$	bar	10 ... 30	
Viscosity range	mm ² /s	10 ... 300	
Max. admissible level of contamination of the hydraulic fluid		ISO 4406 code 20/18/15, achievable with a filter rating of $\beta_{10} \geq 75$	
Fluid temperature range	°C	-20 ... +80	
Division ratio (for others, contact Bucher Hydraulics)		1:1:1	
Fluids		HL/HLP mineral oils DIN 51524; other fluids consult Bucher Hydraulics	
Electrical characteristics (type of actuation: EH)	Unit	Description, Value	
Voltage	V DC	12 or 24	
Power consumption	W	18	
Nitrile seals		NBR	
Duty cycle		100 ED %	
Ambient temperature	°C	max. +60	
Coil temperature	°C	max. +180 (insulation class H)	
Enclosure protection		GDM plug	IP65
		AMP Junior Timer (2-pole)	IP65
		Deutsch-plug, DT04-2P-EP04	IP67
		(DIN EN 60529)	
Electrical connection		Pin matrix to DIN EN 175301-803 AMP Junior Timer plug connector (2-pole) Deutsch-plug, DT04-2P-EP04	

1) State the application's effective nominal flow when ordering.

2) Observe minimum flow rate in accordance with section 4.1.

4 Performance graphs

Measured with viscosity 35 mm²/s.

4.1 Flow resistance

4.1.1 Dividing function switched OFF

(in relation to the input Q_{zu} volume flow rate)

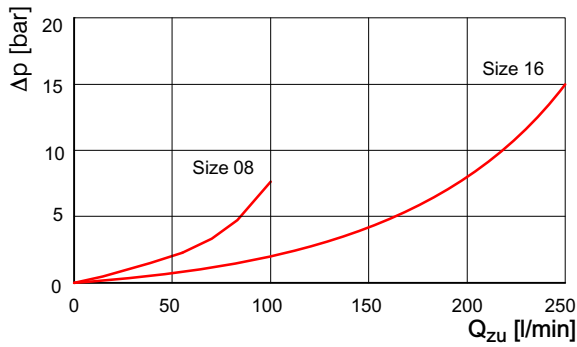

4.2 Division accuracy

Percentage of the applicable flow range without a balancing orifice between A and B (hole plugged)

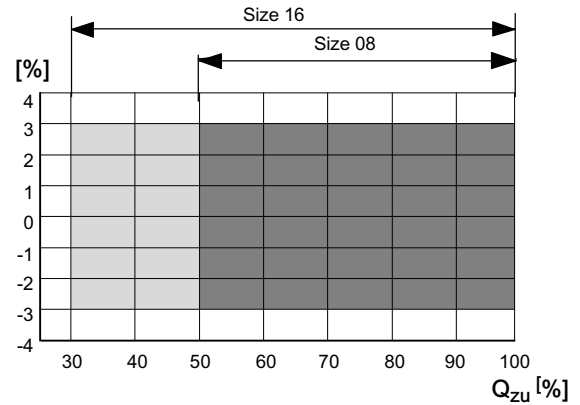

4.1.2 Dividing function switched ON

(in relation to the flow range)

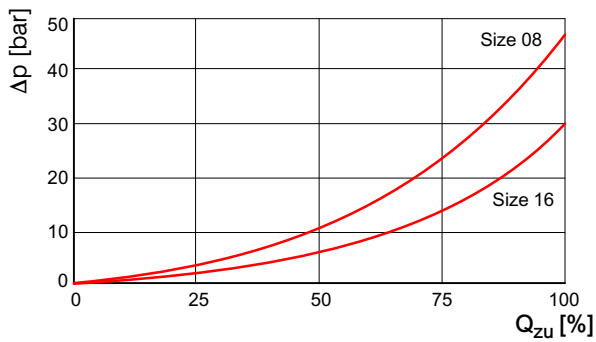

5 Dimensions

5.1 MT08DVD (Serie index 3)

5.1.1 Hydraulic actuation
MT08DVD...-H-3***

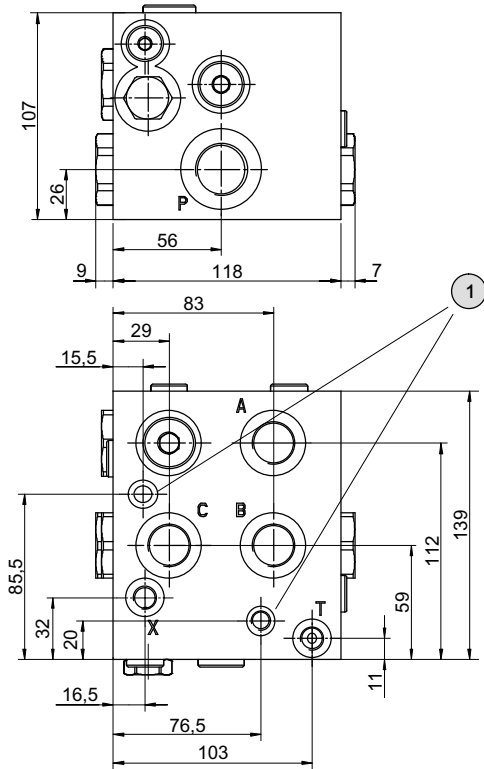

5.1.2 Electrohydraulic actuation
MT08DVD...-EH-3G...

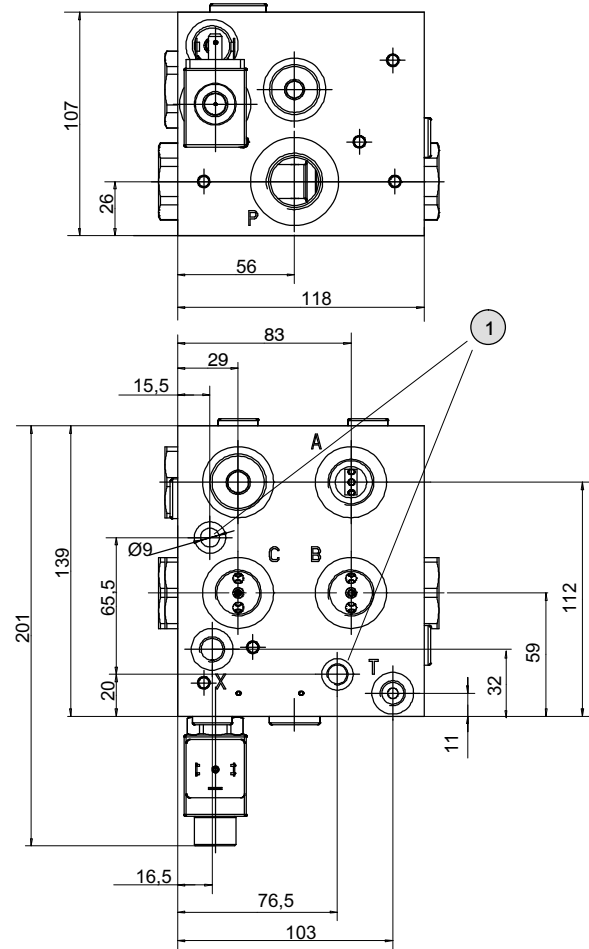

1	Clearance holes for M8 mounting cap screws to DIN 912
---	-------------------------------------------------------

5.2 MT16DVD (Serie index 2)

5.2.1 Hydraulic actuation MT16DVD...-H-2***

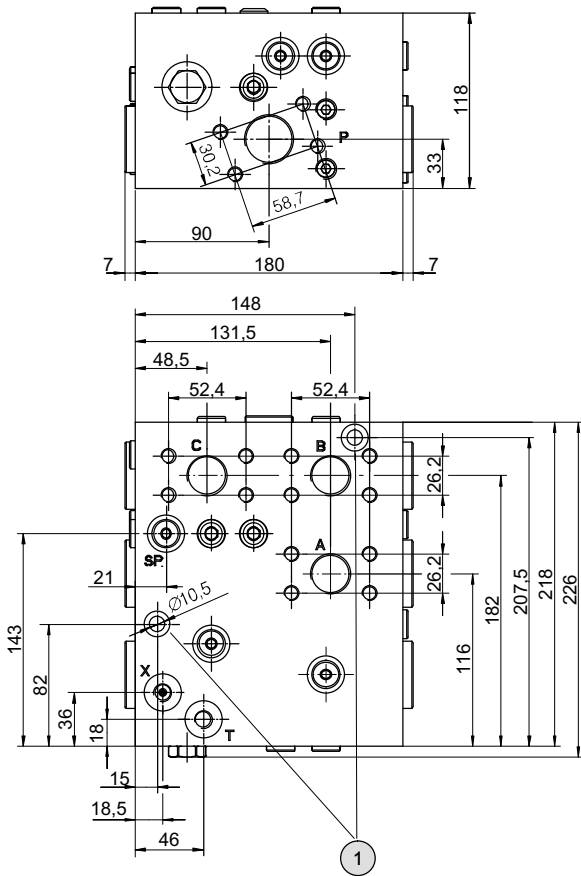

5.2.2 Electrohydraulic actuation MT16DVD...-EH-2G...

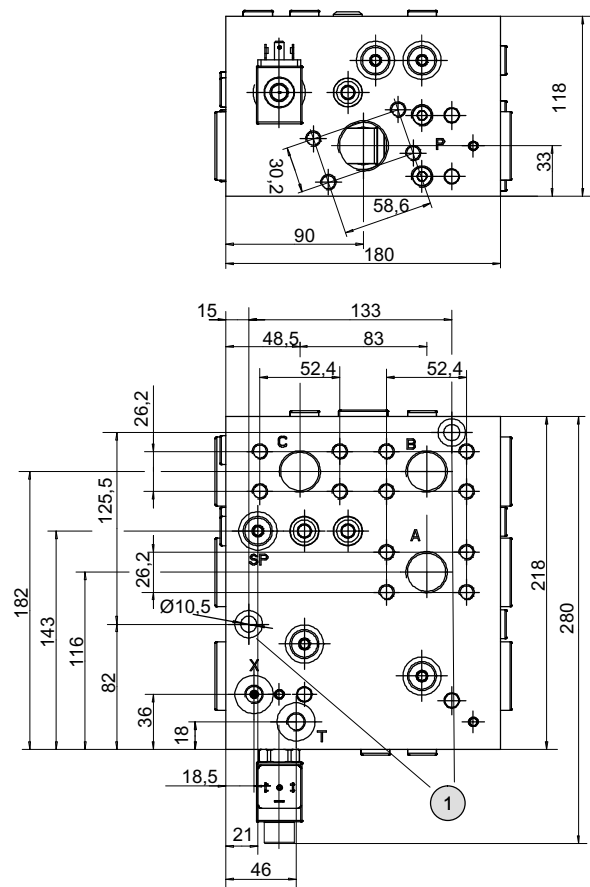

1 Clearance holes for M8 mounting cap screws to DIN 912

5.3 Connection size

MT08DVD		MT16DVD	
Port	Port threads	Port	Port threads
P	M27 x 2	P	M33 x 2 and SAE 1 1/4" (3000 PSI) ¹⁾
A, B, C	M22 x 1,5	A, B, C	M27 x 2 and SAE 1" (3000 PSI) ¹⁾
T, X	M12 x 1,5	T, X	M12 x 1,5

1) SAE-flange see datasheet 100-P-000049

6 Models

6.1 Sockets

GDM plug G	AMP Junior Timer J	Deutsch plug DT04-2P-EP04 T

7 Ordering code

	M	T	0	8	D	V	D	1	0	1	0	0	2	5	-	E	H	-	.	G	1	2	/	*	*	D1 = ... ²⁾ D2 = ...
Series:	= MT..DV																									
Nom. Size:	= 08 or 16																									
3-way differential lock valve:	= D																									
Division ratio, A to (B+C):	1 : 1 = 10 1 : 1,5 = 15 etc. 1)																									
Division ratio B to C:	1 : 1 = 10 1 : 1,5 = 15 etc. 1)																									
Control flow range:	e.g. 25 l/min per sect. 3 = 025																									
Type of actuation :	hydraulic = *H electrohydraulic = EH																									
Design stage	0 - 9 (insert by Bucher Hydraulics)																									
Plug connector:	GDM-plug = G AMP Junior Timer = J Deutsch-plug DT04-2P-EP04 = T																									
Coil voltage:	DC 12 Volt = 12 DC 24 Volt = 24 bei Betätigungsart *H = ***																									
Option: (see section 7.1):	with make-up valve = 01 with anti-shock valves = 02 with make-up valve + inch-size port threads = 07																									

1) With unequal division between A and (B+C), the larger flow goes to (B+C) between B and C, the larger flow goes to C.

2) Size of balancing orifices must be plainly stated (see also sect. 2) e.g. 0.6 / 0.8 / 1.0 e.g. if balancing orifice D1 is to be 0.8 mm, then D1 = 08 if balancing orifice D2 is to be 1.0 mm, then D2 = 10

7.1 Options

In addition to the standard versions, differential-lock valves can also be equipped with numerous auxiliary functions and combined in customer-specific manifold blocks. In these cases, technical datas and performance graphs may differ from standard.

- /01 = With make-up valve
- /02 = With anti-shock valves (pressure-relief+make-up valves)
- /07 = with make-up valves and inch-size port threads

8 Application example

8.1 3-wheel Drive

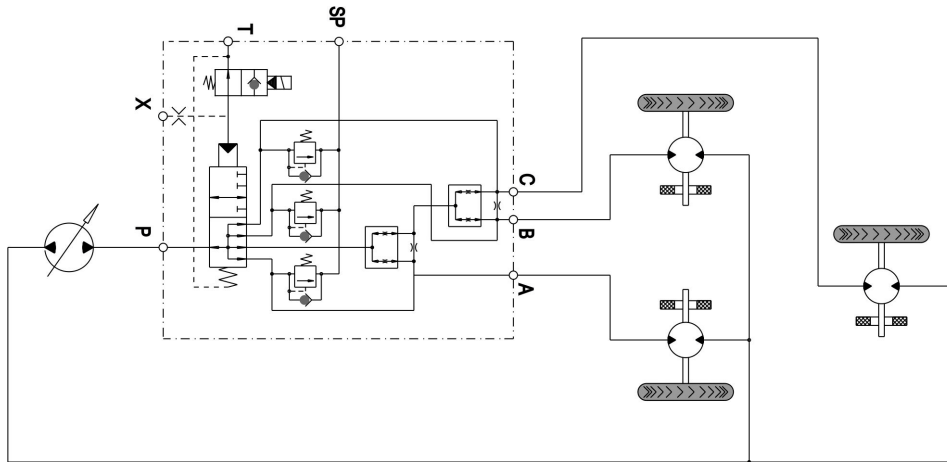

9 Accessories

9.1 Pipe flanges - high pressure type (thread flange)

- Max. operating pressure 420 bar
- Flange size SAE J518 code 61 / ISO 6162-1

Threaded pipe flanges are spot-faced for DIN 2353 pipe fittings
Material: ST37 / for Viton seals (contact Bucher Hydraulics GmbH)

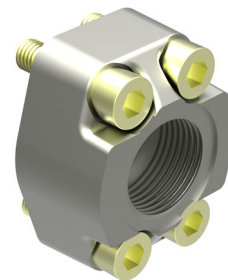
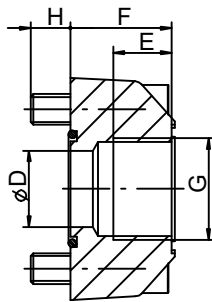
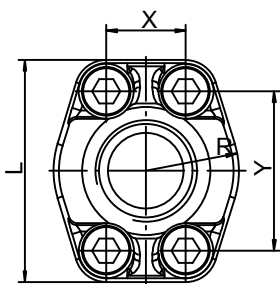

Ordering number	Ordering code	Size	DØ	E	F	H	L	R	X	Y	Viton seal 90 Shore A	Retaining screws DIN912-12.9 [Nm]
100037020	RF 03-R11	G1"	25	20	34	13	70	29	26,2	52,4	32,99x2,62	M10x35 60
100037030	RF 04-R12	G1¼"	32	22	38	14	80	36	30,2	58,6	40,86x3,53	M10x40 60

Other pipe flanges on request

10 Installation

Horizontal mounting is recommended. Do not bolt the valve body onto an uneven mounting surface.

11 Fluid

Differential lock valves require fluid with a minimum cleanliness level of ISO 4406 code 20/18/15.

We recommend the use of fluids that contain anti-wear additives for mixed-friction operating conditions. Fluids without appropriate additives can reduce the service life of pumps and motors.

The user is responsible for maintaining, and regularly checking the fluid quality.

12 Fluid cleanliness class

Cleanliness class (RK) onto ISO 4406.

Code ISO 4406	Number of particles / 100 ml		
	≥ 4 µm	≥ 6 µm	≥ 14 µm
23/21/18	8000000	2000000	250000
22/20/18	4000000	1000000	250000
22/20/17	4000000	1000000	130000
22/20/16	4000000	1000000	64000
21/19/16	2000000	500000	64000
20/18/15	1000000	250000	32000
19/17/14	500000	130000	16000
18/16/13	250000	64000	8000
17/15/12	130000	32000	4000
16/14/12	64000	16000	4000
16/14/11	64000	16000	2000
15/13/10	32000	8000	1000
14/12/9	16000	4000	500
13/11/8	8000	2000	250

13 System augmentation

13.1 Switch valve for traction drives

13.1.1 USV08 and USV16 series

These valves enable switching from a serial connection, for example "drive mode," into a parallel connection using a differential lock valve. For the user, such solutions mean reliable output and fast operating speeds.

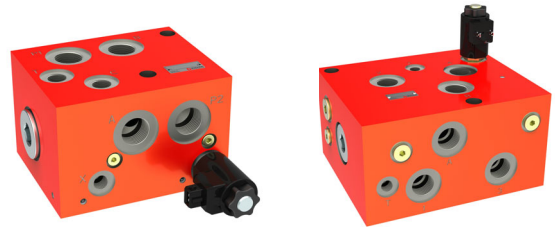

13.1.2 Application examples

- Sweepers
- Cold milling machines
- Black-top pavers
- Forklifts
- Compact rollers

13.1.3 Circuit diagram

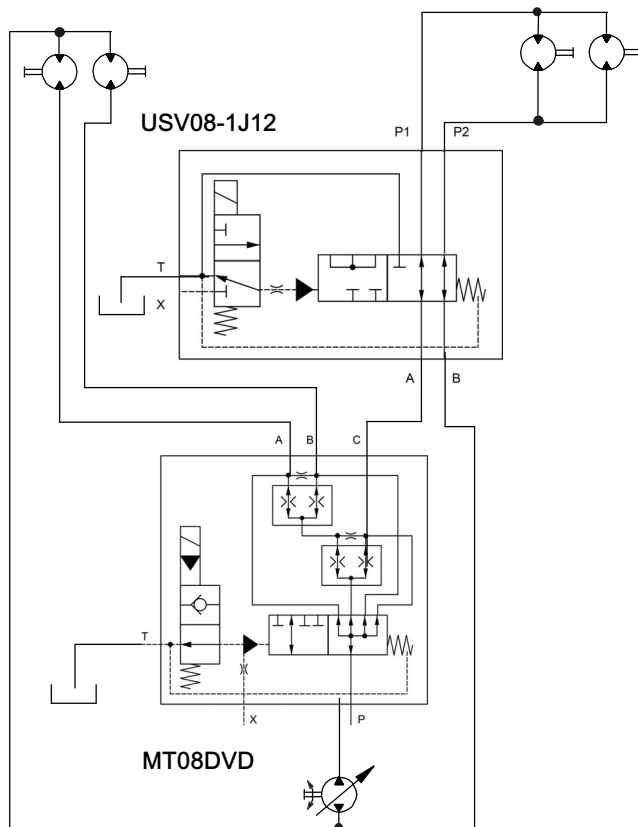

USV16-0G12

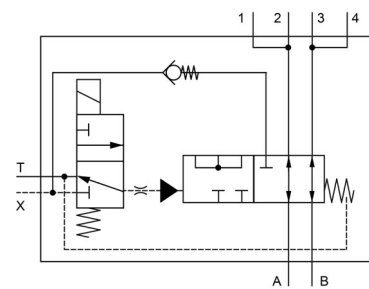

USV08-1J12

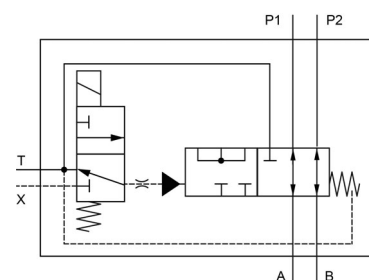

13.1.4 Technical data

Hydraulical characteristics	Unit	Description, Value	
		Size 08	Size 16
Operating pressure p_{max}	bar	420	420
Nominal flow rate	l/min	120	160
Dimensions (valve body without solenoid)	mm	160x105x130	220x118x185
Ordering Information and order number		USV08-1J12 = 100032930	USV16-0G12 = 100028253
Fluid temperature range	°C	-20 ... +80	
Viscosity range	mm ² /s	10 ... 300	
Maximum fluid cleanliness		ISO 4406 class 20/18/15; achievable with a filter rating of $\beta_{10} \geq 75$	
Nitrile seals		NBR (Nitril-Butadien-Kautschuk)	
Port threads: USV08		P1, P2, A, B = M27x2 T, C = M18x1,5 X = M14x1,5 according to DIN EN ISO 9974-1	
USV16		1 - 4, A, B = M27x2 T = M14x1,5 X = M14x1,5 according to DIN EN ISO 9974-1	
Electrical characteristics	Unit	Description, Value	
Supply voltage	V DC	12 or 24	
Supply voltage tolerance		± 10%	
Nominal power consumption - version „N“ - version „E“	V DC	V DC = 27 W / V AC = 25 W V DC = 17 W / V AC = 17 W	
Switching time	ms	Version „E“ (17W): 25 ... 70 (energising) 15 ... 50 (deenergising) Version „N“: (27/25W): 25 ... 100 (energising) 20 ... 70 (deenergising) These times are strongly influenced by fluid pressure, flow rate and viscosity, as well as by the dwell time under pressure.	
Relative duty cycle		100%	
Protection class to EN 60 529		IP68 (when connector plugs are properly fitted)	
Electrical connection		3-pin square plug to ISO 4400 / DIN 43 650 (standard) Deutsch-plug DT04-2P-EB04, AMP Junior Timer (2-pole)	

info.kl@bucherhydraulics.com

www.bucherhydraulics.com

© 2020 by Bucher Hydraulics GmbH, D-79771 Klettgau

All rights reserved.

Data is provided for the purpose of product description only, and must not be construed as warranted characteristics in the legal sense. The information does not relieve users from the duty of conducting their own evaluations and tests. Because the products are subject to continual improvement, we reserve the right to amend the product specifications contained in this catalogue.

Classification: 430.390.335.310.