

Differential Lock Valve

Series MT..DVV (for 4 motors)

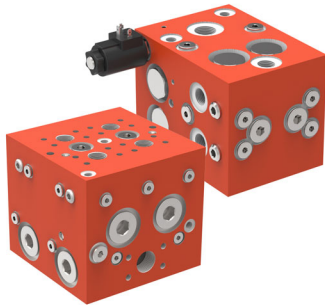

- robust and reliable
- energy-optimised over the whole flow range
- simple control
- compact design offers space-saving installation
- reliable, uniform motion of the wheel-drives being controlled



OIL SOLUTIONS

PO Box 38
Strathfieldsaye, VIC, 3551
1800 OIL SOL
1800 645 765

sales@oilsolutions.com.au
www.oilsolutions.com.au

"For All Your Hydraulic Needs"

1 Description

1.1 General

The differential lock valve consists essentially of three bi-directional flow dividers (dividing and combining) and a directional valve for optionally bypassing the flow dividers. It is intended for use in either open- or closed-loop hydrostatic drives with parallel-connected hydraulic motors. When the lock valve is switched OFF, the inlet flow can divide itself among the motors in any required manner. When the lock valve is switched ON, however, the inlet flow is divided into four pressure compensated portions in accordance with the division ratio of the lock valve. The motors are

thus driven at fixed speeds, regardless of their respective loads. This arrangement prevents any hydraulic wheel motor from spinning in conditions of poor traction. Three balancing orifices can optionally be arranged between the outlets A, B, C and D. These allow some redistribution of flow and prevent unwanted torque build-up between wheels in these circumstances, and when turning.

The differential lock valves can be supplied with either hydraulic, or electro-hydraulic, actuation.

1.2 Application examples

- Construction equipment
- Lifting platforms
- Agricultural equipment

2 Symbols

2.1 Hydraulic actuated

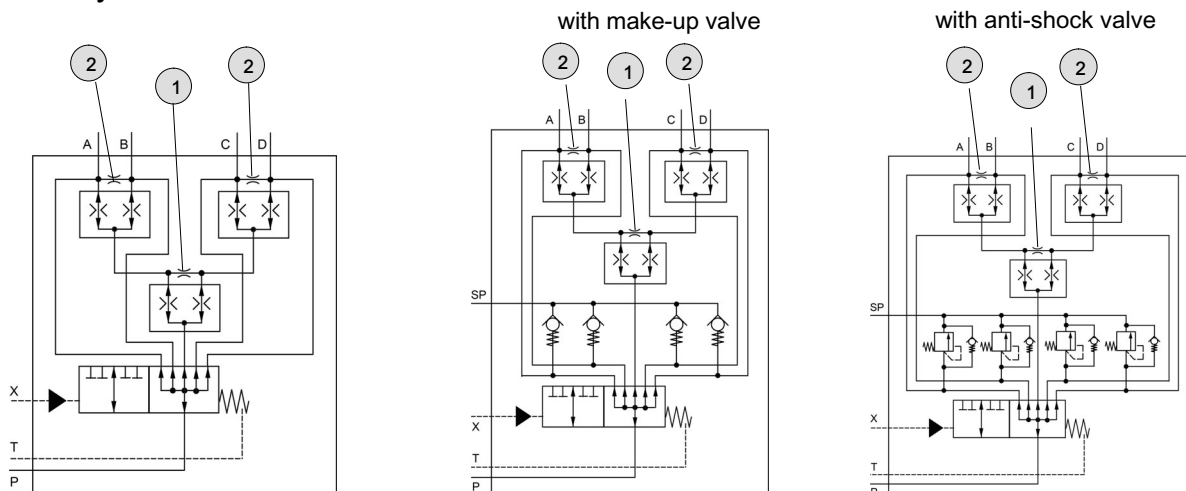

1 Balancing orifice D2 can be fitted

2 Balancing orifice D1 can be fitted

Reference: 100-P-000171-US-03

2.2 Electrohydraulic actuated

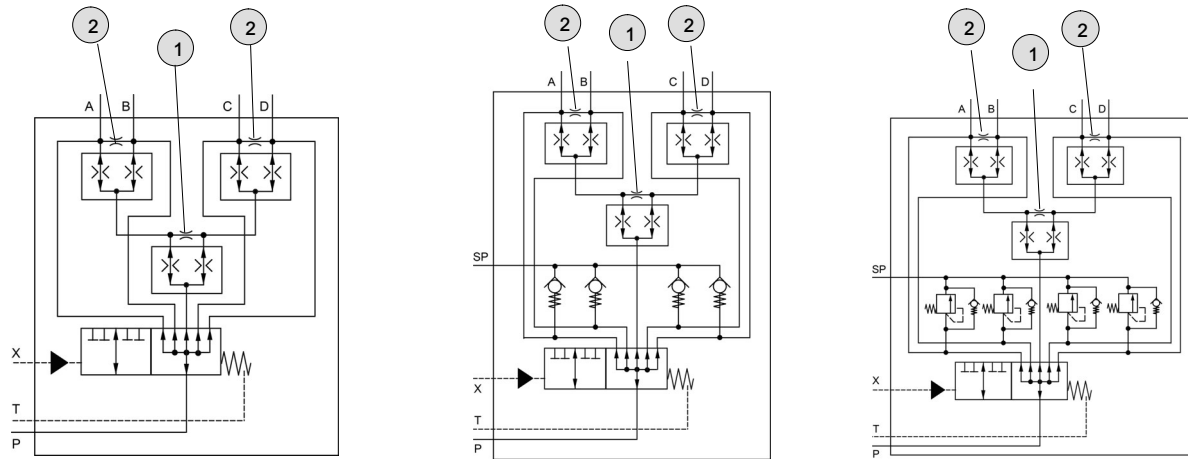

1 Balancing orifice D2 can be fitted

2 Balancing orifice D1 can be fitted

3 Technical data

Hydraulic characteristics	Unit	Description, value	
		Size 08	Size 16
Nominal flow rate	GPM	26,42 (100 l/min)	66,04 (250 l/min)
Flow range ^{1) 2)}	l/min	25, 50, 75, 100	120, 160, 200, 250
Flow range ^{1) 2)}	GPM	6,6 / 13,21 / 19,81 / 26,42	31,7 / 42,27 / 52,83 / 66,04
Operating pressure p_{max}	PSI	6092 (420 bar)	
Pilot pressure p_p min.- p_p max.	PSI	145 ... 435 (10 bar ... 30 bar)	
Viscosity range	ft ² /s	1,08 ... 32,4 (10 mm ² /s ... 300 mm ² /s)	
Max. admissible level of contamination of the hydraulic fluid		ISO 4406 code 20/18/15, achievable with a filter rating of $\beta_{10} \geq 75$	
Fluid temperature range	°F	-4 ... +176 (-20 °C ... +80 °C)	
Division ratio (other values on request)		1:1:1	
Fluids		HL/HLP mineral oils DIN 51524; other fluids consult Bucher Hydraulics	
Electrical characteristics (type of actuation: EH)	Unit	Description, value	
Voltage	V DC	Direct current voltage 12 or 24	
Power consumption	W	18	
Nitrile seals		NBR	
Duty cycle		100% ED	
Ambient temperature	°F	max. +140 (+60 °C)	
Coil temperature	°F	max. +356 (+180 °C) (insulation class H)	
Enclosure protection DIN 40050		GDM Stecker DIN 43650	IP54
		Deutsch Stecker DT04-2P-EP	IP67
		AMP Junior Timer (2-polig)	IP65
Electrical connection		GDM plug DIN 43650: Deutsch plug DT04-2P-EP04 AMP Junior Timer plug connector (2-pole)	

1) State the application's effective nominal flow when ordering.

2) Observe minimum flow rate in accordance with section 4.1.

4 Performance graphs

Measured with viscosity 3,78 ft²/s

4.1 Flow resistance

4.1.1 Dividing function switched OFF

(in relation to the input Q_{zu} volume flow rate)

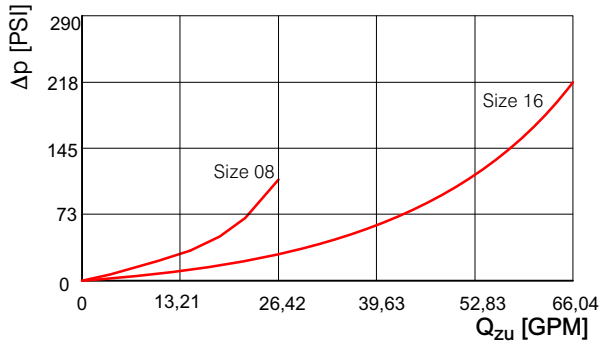

4.1.2 Dividing function switched ON

(in relation to the flow range)

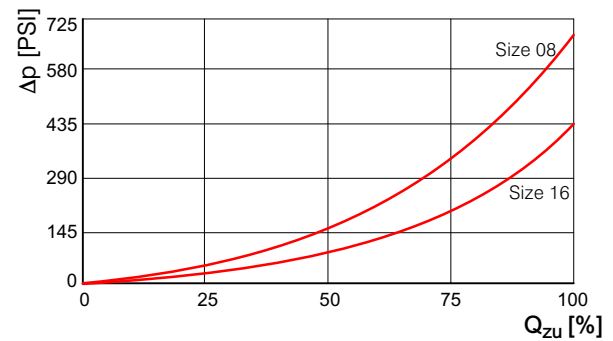

4.2 Division accuracy

Percentage of the applicable flow rate without a balancing orifice between A and B (hole plugged)

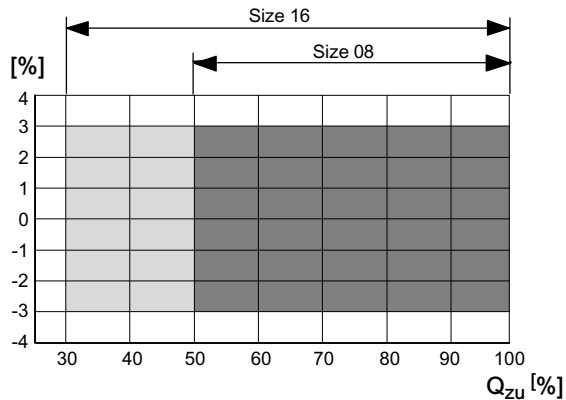

5 Dimensions in inch

5.1 MT08DVV...-H-0*** (hydraulic actuated)

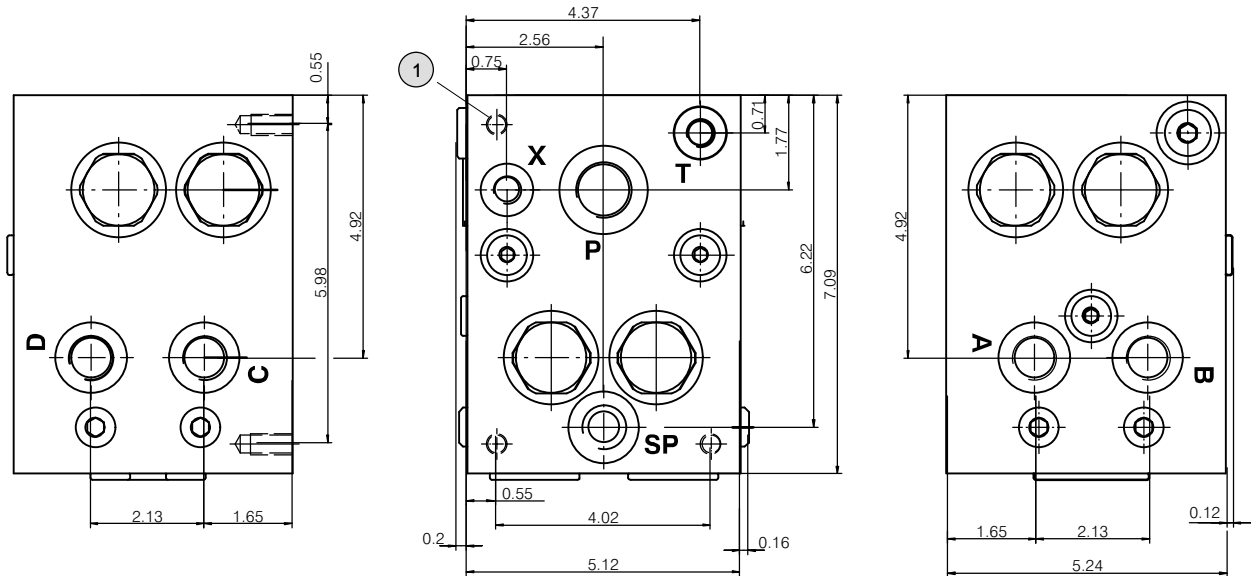

1 4x Mounting thread M10 - 20mm deep

5.2 MT08DVV...-EH-0G... (elektrohydraulic actuated)

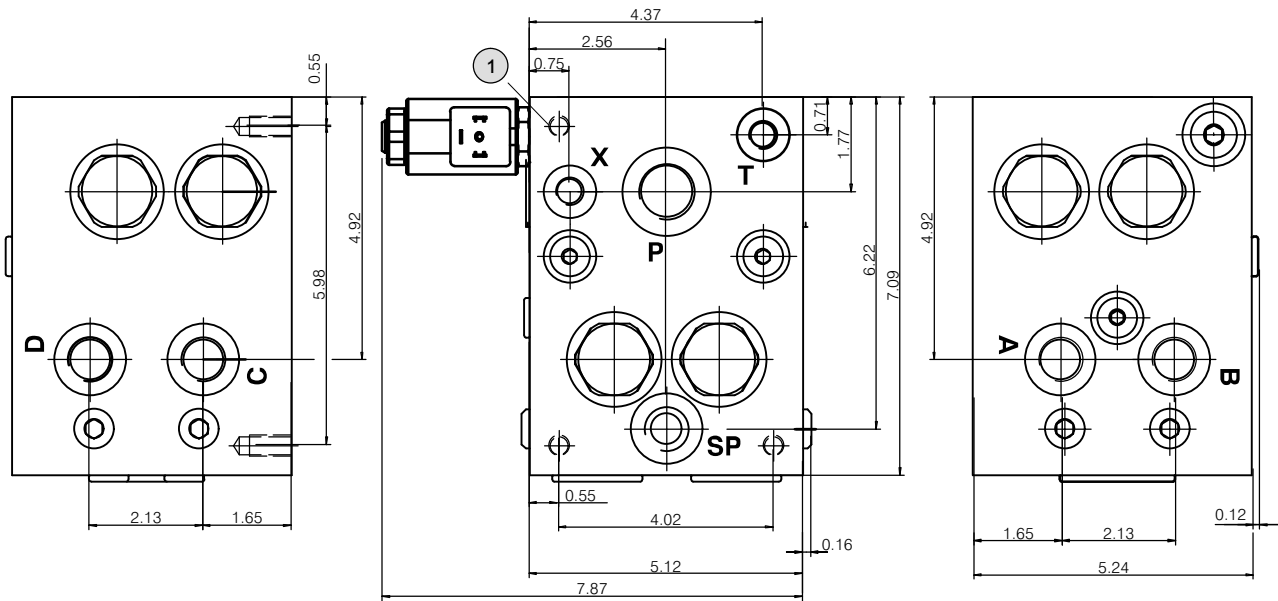

1 4x Mounting thread M10 - 20mm deep

5.3 MT16DVV...-H-0*
(hydraulic actuated)**

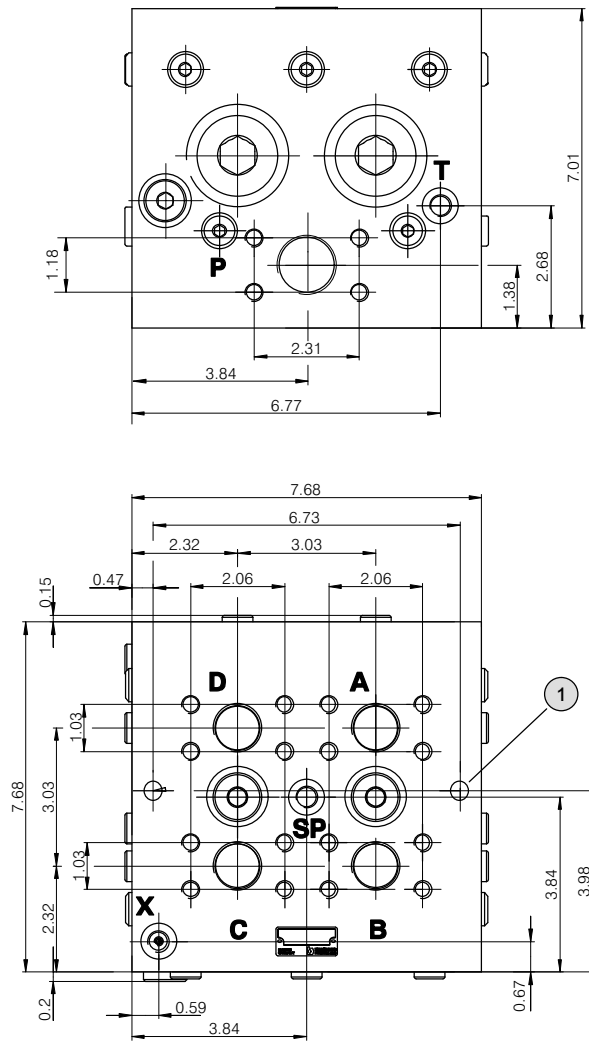

**5.4 MT16DVV...-EH-0G...
(elektrohydraulic actuated)**

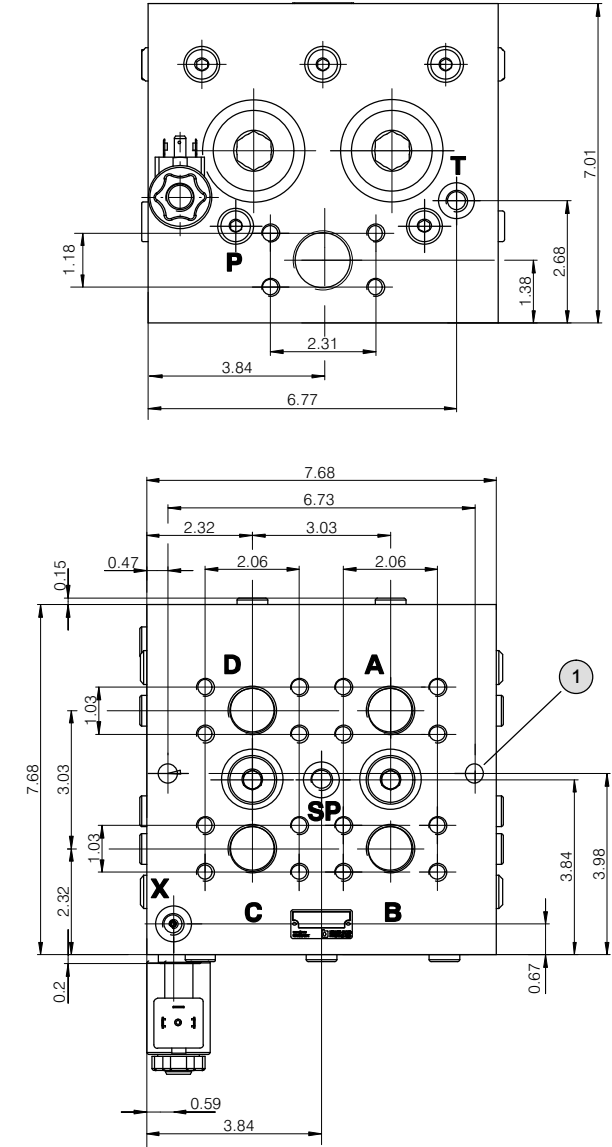

1 Clearance holes for M8 mounting cap screws to DIN 912

5.5 Connection size

MT08DVV		MT16DVV	
Port	Port threads	Port	Port threads
P	G 3/4"	P	M33 x 2 and. SAE 1 1/4" (3000 PSI) 1)
A, B, C, D, SP	G 1/2"	A, B, C, D	M27 x 2 and SAE 1" (3000 PSI) 1)
T, X	G 1/4"	T, X, SP	M12 x 1,5

1) SAE flanges see data sheet 100-P-000049

6 Models

6.1 Sockets

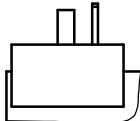
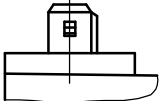
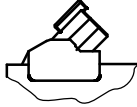
GDM plug to DIN 43650 -G..	AMP Junior Timer -J..-	Deutsch plug DT04-2P-EP04 -T..-
		

7 Ordering code

	M	T	0	8	D	V	V	1	0	1	0	1	0	0	2	5	-	E	H	-	3	G	1	2	*	*	D1 = ... ²⁾	D2 = ...
Series:	= MT..DV																											
Nom. size :	= 08 oder 16																											
4-way differential lock valve:	= V																											
Division ratio, A + B to C+D:	1:1 = 10																											
	1:1,5 = 15 etc. ¹⁾																											
Division ratio A to B:	1:1 = 10																											
	1:1,5 = 15 etc. ¹⁾																											
Division ratio C to D:	1:1 = 10																											
	1:1,5 = 15 etc. ¹⁾																											
Control flow range:	z. B. 25 l/min		= 025																									
	per section.3																											
Type of actuation:	hydraulic		= *H																									
	electrohydraulic		= EH																									
Design stage:	0 - 9		(insert by Bucher Hydraulics)																									
Plug connector:	GDM plug (DIN 43650)		= G																									
	AMP Junior Timer		= J																									
	Deutsch plug DT04-2P-EP04		= T																									
Coil voltage:	DC 12 Volt		= 12																									
	DC 24 Volt		= 24																									
	operating mode *H		= ***																									
Option (see section 7.1):	with make-up valve		= 01																									
	with anti-shock valves		= 02																									

1) With unequal division:
Between A+B to C+D, the larger flow goes to C+D,
Between A and B, the larger flow goes to B,
Between C and D, the larger flow goes to D

2) Size of balancing orifices must be plainly stated (see also sect. 2) e.g. 0.6 / 0.8 / 1.0 ,
e.g. if balancing orifice D1 is to be 0.8 mm, then D1 = 08 if balancing orifice D2 is to be 1.0 mm, then D2 = 10

7.1 Options

In addition to the standard versions, differential-lock valves can also be equipped with numerous auxiliary functions and combined in customer-specific manifold blocks. In these cases, technical datas and performance graphs may differ from standard.

/01 = with make-up valve

/02 = with anti-shock valves (pressure-relief+make-up valves)

7.1.1 Examples

7.1.1.1 MT..DVV.....-EH-0G../01
With make-up valves

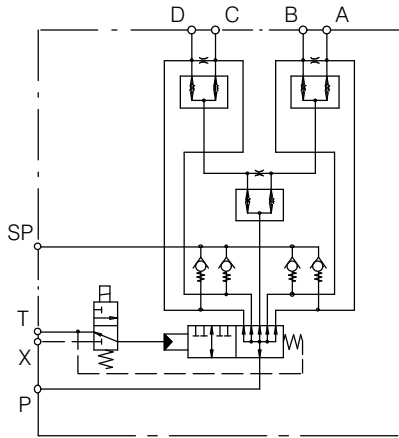

7.1.1.2 MT..DVV.....-EH-0G../02
With anti-shock valves
(pressure-relief+make-up valves)

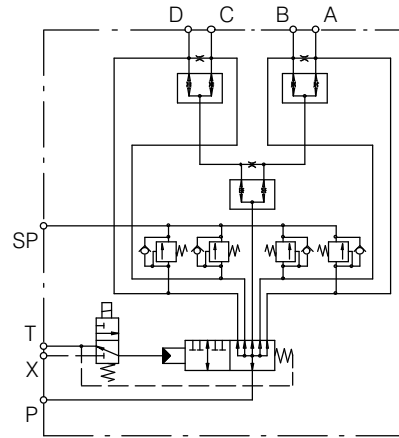

8 Application example

8.1 4-wheel drive with the same flow rates at all 4 wheel motors.

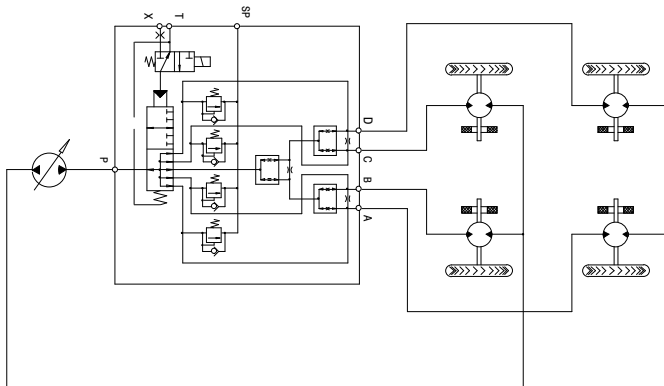

9 Accessories

9.1 Pipe flanges - high pressure type (thread flange)

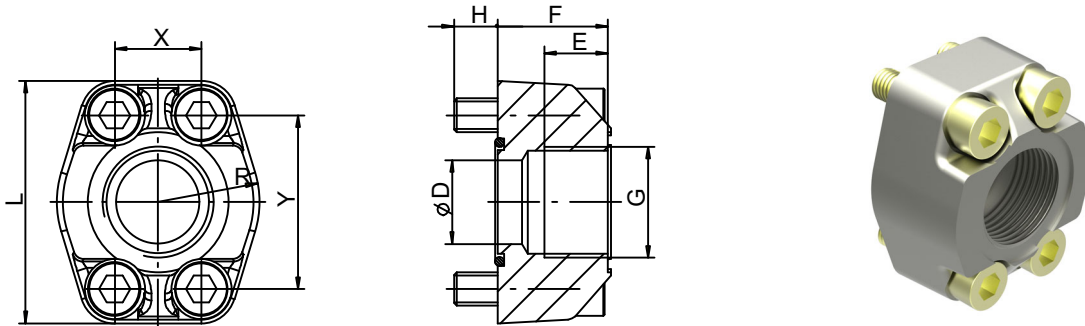

- Max. operating pressure 420 bar
 - Flange size SAE J518 code 61 / ISO 6162-1
- Threaded pipe flanges are spot-faced for DIN 2353 pipe fittings
Material: ST37 / for Viton seals, contact Bucher Hydraulics GmbH

Ordering-number	Ordering code	Size	D \varnothing	E	F	H	L	R	X	Y	Viton seal 90 Shore A	Retaining screws DIN912-12.9 / [Nm]	
100037020	RF 03-R11	G 1"	25	20	34	13	70	29	26,2	52,4	32,99x2,62	M10x35	60
100037030	RF 04-R12	G11/4"	32	22	38	14	80	36	30,2	58,6	40,86x3,53	M10x40	60

* other pipe flanges on request

10 Installation

Horizontal mounting is recommended. Do not bolt the valve body onto an uneven mounting surface.

11 Fluid

Differential lock valves require fluid with a minimum cleanliness level of ISO 4406 code 0/18/15.

We recommend the use of fluids that contain anti-wear additives for mixed-friction operating conditions. Fluids without appropriate additives can reduce the service life of pumps and motors.

The user is responsible for maintaining, and regularly checking the fluid quality.

12 Fluid cleanliness class

Cleanliness class (RK) onto ISO 4406.

Code ISO 4406	Number of particles / 100 ml		
	$\geq 4 \mu\text{m}$	$\geq 6 \mu\text{m}$	$\geq 14 \mu\text{m}$
23/21/18	800000	200000	250000
22/20/18	400000	100000	250000
22/20/17	400000	100000	130000
22/20/16	400000	100000	64000
21/19/16	200000	50000	64000
20/18/15	100000	25000	32000
19/17/14	50000	13000	16000
18/16/13	25000	6400	800
17/15/12	13000	3200	400
16/14/12	6400	1600	400
16/14/11	6400	1600	200
15/13/10	3200	800	100
14/12/9	1600	400	50
13/11/8	800	200	25

info.kl@bucherhydraulics.com

www.bucherhydraulics.com

© 2019 by Bucher Hydraulics GmbH, D-79771 Klettgau

All rights reserved.

Data is provided for the purpose of product description only, and must not be construed as warranted characteristics in the legal sense. The information does not relieve users from the duty of conducting their own evaluations and tests. Because the products are subject to continual improvement, we reserve the right to amend the product specifications contained in this catalogue.

Classification: 430.310.336.347.000