

# System Solutions for Small and Mid-Range Salt/Grit Spreaders

---

System overview



1800-OILSOL  
1800-645765

<https://oilsolutions.com.au/>

[sales@oilsolutions.com.au](mailto:sales@oilsolutions.com.au)



Setting a load-independent working speed for motors or cylinders

# Flow Control Valve for Municipal Equipment

## Flow control valve, series SRCA

- Optimum flow control range 0 ... 50 l/min
- Flow rates unaffected by temperature changes or alternating loads
- Minimum pressure drop
- Satisfies exacting demands on corrosion protection thanks to zinc-nickel coating
- The slip-on coil can be rotated, and it can be replaced without opening the hydraulic envelope

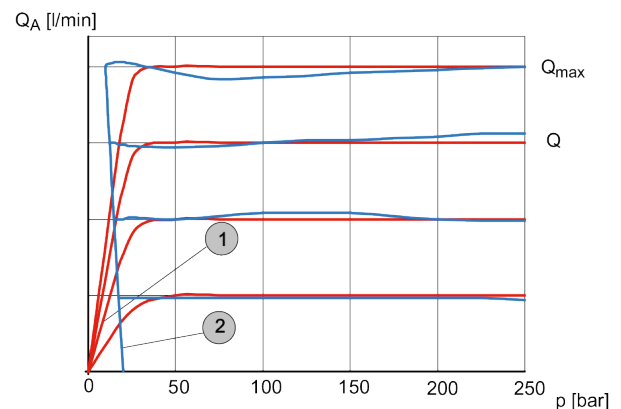
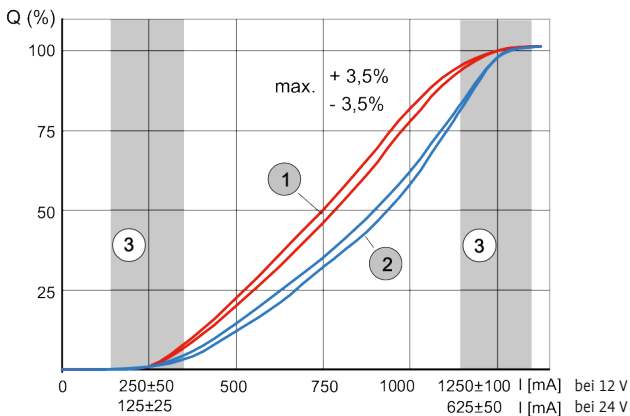
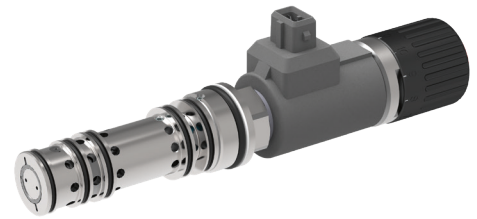

- Key:**
- ① Q-I characteristic at 50 L
  - ② Q-I characteristic at 25 L
  - ③ Fine control range

- ①  $Q_A$  - constant flow pressurised
- ②  $Q_A$  - surplus flow pressurised

## Technical Data

### Hydraulic characteristics

	Description, value
Constant flow range	10, 16, 25, 32, 40, 50 l/min
Maximum flow rate	60 l/min
Maximum operating pressure	250 bar
Maximum leakage flow	60 cm <sup>3</sup> /min at 100 bar (or virtually zero if the priority flow discharges to tank)
Min. pressure difference (pressure compensator)	4 ... 7 bar
Control accuracy (as a % of the nominal flow):	
Load-dependency when under pressure	± 2,5 %
Hysteresis when operated	± 3,5 %
Hydraulic fluid	Mineral oil to DIN 51524 and DIN 51525
Hydraulic fluid temperature range	-20 °C ... +80 °C
Viscosity range	10 ... 300 mm <sup>2</sup> /s (cSt)
Minimum fluid cleanliness; Cleanliness class to ISO 4406:1999	Class 20/18/15

Further information see data sheet 100-P-000144

Adaptable hydraulic combinations for controlling a wide variety of salt/grit spreaders

# Valve Block Solutions

Valve block for spinner/screw

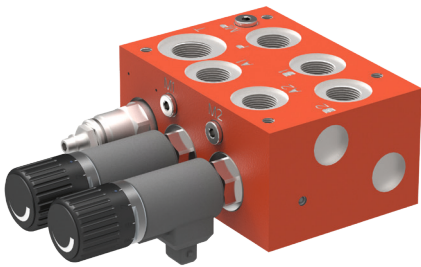

Valve block for spinner/screws/brine pump

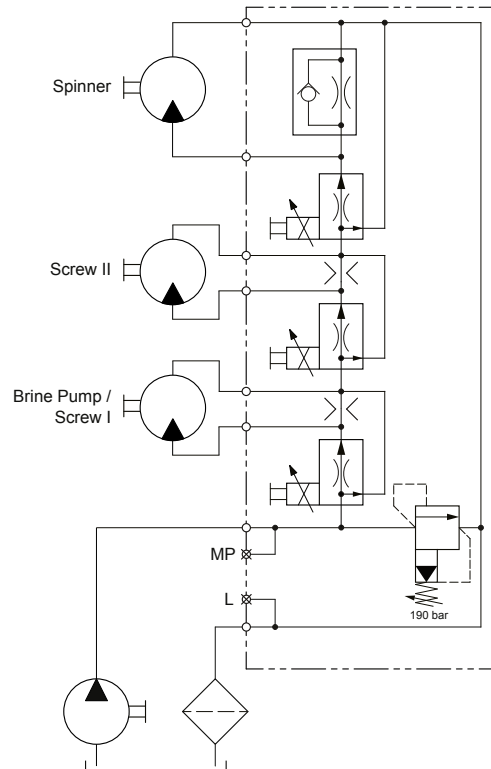
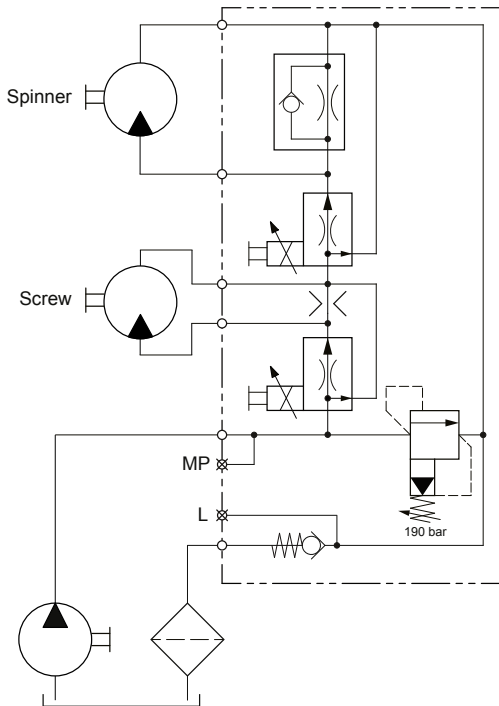
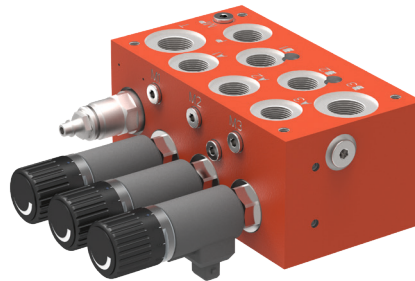

# System Components for Operation

---

Freely combinable electronic components for controlling a wide variety of salt/grit spreaders

---

## Display controller JetViewMobile 104

- Control unit with integrated PLC functionality
- Flexibly configurable JetSpread application software for hydraulically driven spreaders
- 3.5" color TFT screen with backlighting
- Encoder with push-button function and 8 illuminated keys
- 2 CAN interfaces for the internal system functions
- RS232 interface for data logging
- USB interface for software updates and for easy system parametrization via USB stick
- Connection via Deutsch plug
- RAM-mount adaption prepared



---

## Additional control unit JXM-HMI

- 3 encoders with push-button function (start/stop) for screws and spinner plate
- Designed for use at night
- CANopen interface for connection to the JVM 104
- Fitted with the JVM 104 on a common mounting plate, or separately



---

## CANopen®-Slave JXM-IO-E30

- 14 outputs for hydraulic valves, actuators and lighting
- 12 inputs for sensors, including ground-switching speed signals
- 3 short-circuit-protected sensor supplies
- Outputs are short-circuit-protected and diagnosable



**Advantages:**

- Intuitive and safe operation of all relevant functions with 4 rotary encoders
- Clear display with large graphic elements
- Standard and custom software with all typical functions
- Integrated diagnostic function including fault memory
- Customized front-foil design can be supplied
- USB interface for easy upload of software and parameters

**Control functions:**

- Operation of the spinner plate (current-regulated or speed-controlled)
- Operation of max. 2 screw conveyors (current-regulated or speed-controlled)
- Operation of max. 2 brine pumps (one of which is current-regulated or speed-controlled)
- Control of the spreading rate is travel-speed dependent
- Spread-pattern adjustment with position feedback
- Monitoring of spread control, spinner-plate folding, and fill levels
- Operation of beacons and work lights
- Control of devices with spray bars and feed rollers



# Available Models

---

Coordinated, ergonomic control solutions for small and mid-range salt/grit spreaders

---

## Economy

- Inputs and outputs integrated in the display controller
- Proportional duty-cycle control for 2 screw conveyors and 1 spinner plate (without current control)
- Travel signal/speed control



---

## Professional

- Full range of functions for all inputs/outputs
- USB/RS232 interfaces (included)
- Integral real-time clock (battery buffered)
- Data logging to DIN EN15430-1



---

## System parametrization

- Flexible adjustment of all valve currents
- Simple sensor setup/adjustment
- Selection of the various spreading media and adjustment of the screw conveyors
- Simple weighing
- All hoppers can be emptied separately when the gritter is stationary
- Test mode with travel-speed simulation
- Diagnostic function with fault memory

# System Solution at a Glance

Coordinated system solutions with components from Bucher Hydraulics and Jetter for small and mid-range salt/grit spreaders

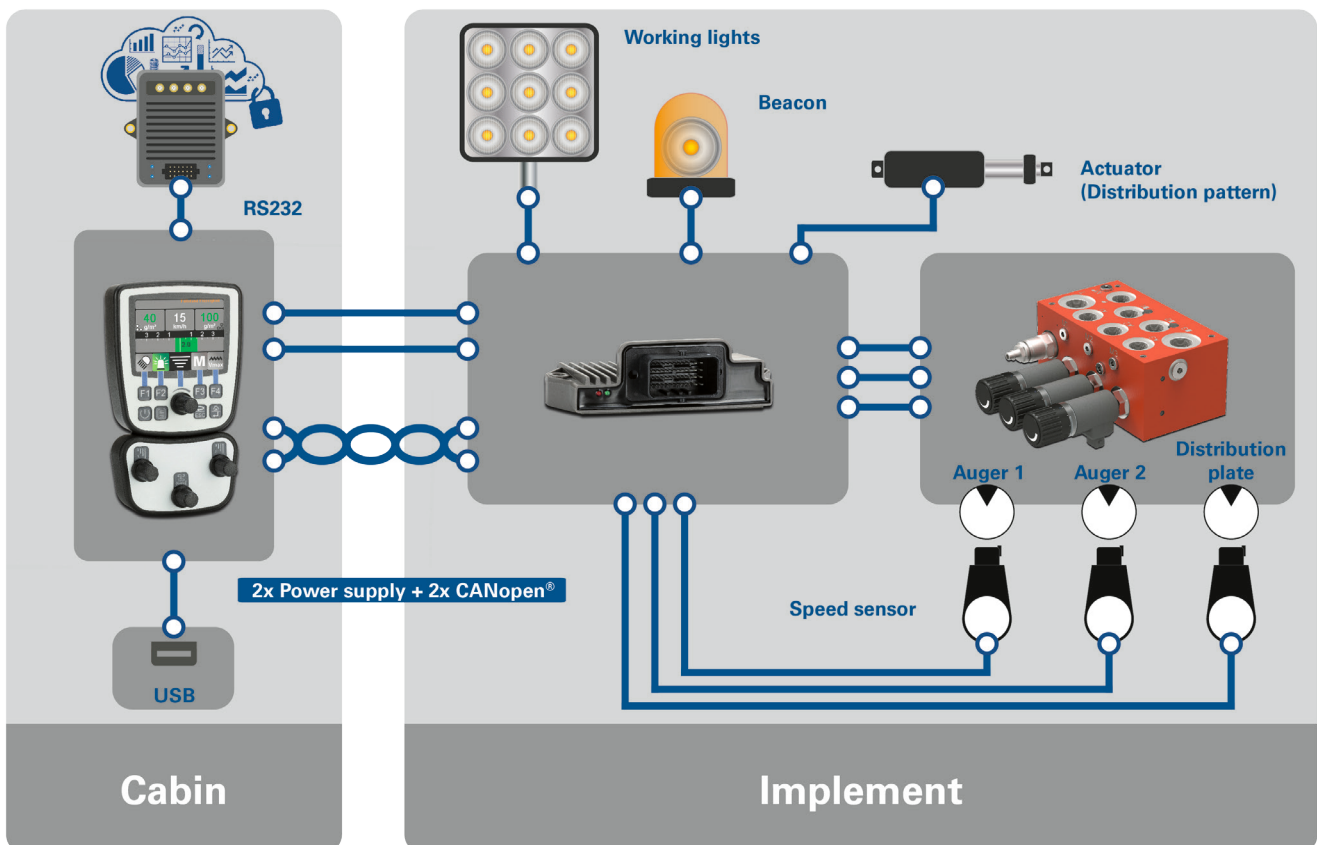

[bucherhydraulics.com](https://www.bucherhydraulics.com)

---

**Bucher Hydraulics GmbH**  
Industriestraße 1  
79771 Klettgau, Germany  
T +49 7742 852 0  
[info@bucherhydraulics.com](mailto:info@bucherhydraulics.com)