

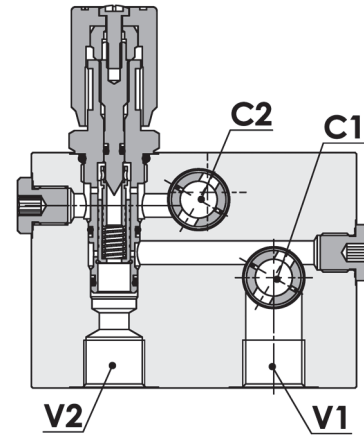

**Regolatore di flusso a 3 vie compensato, con eccedenza a scarico, flangiabile su motori Char-Lynn 2000**  
**Three way, pressure compensated flow regulator, with exceeding flow to tank, flangeable on Char-Lynn 2000 motors**

Rev.01-2010/02

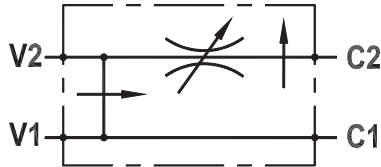

**SPECIFICHE TECNICHE**

**Materiali:** cartucce in acciaio zincato, parti interne in acciaio trattato termicamente. Corpo in lega di alluminio.

**Portata max.:**

- 50 l/min con 30 l/min su ramo regolato "C2"

**Pressione max:** 250 bar (corpo in alluminio)

**Pressione di standby:** 12 bar

**Peso:** 1,250 Kg

**TECHNICAL SPECIFICATIONS**

**Materials:** cartridges in steel zinc plated, internal parts in hardened steel. Body is in high strength aluminium alloy.

**Rated flow:**

- 50 l/min with 30 l/min in "C2" port

**Max. pressure:** 250 bar (aluminium body)

**Standby pressure:** 12 bar

**Weight:** 1,250 Kg

**DIAGRAMMA COMPENSAZIONE - COMPENSATION CURVES**

Viscosità olio 24 mm<sup>2</sup>/sec. (3,5 °E)  
 Temperatura 50 °C

Oil viscosity 24 mm<sup>2</sup>/sec. (3,5 °E)  
 Temperature 50 °C

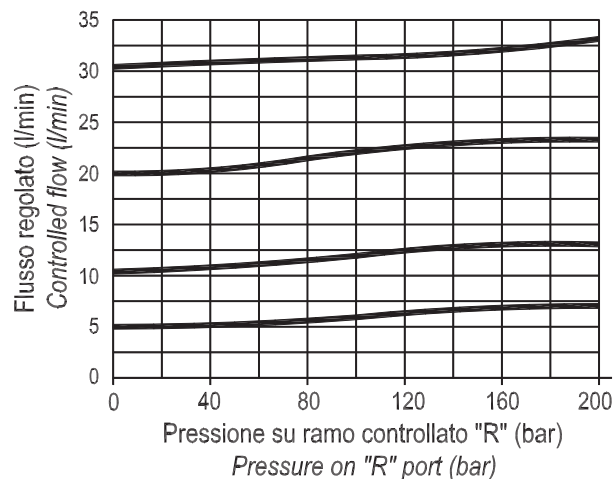

Regolatore di flusso a 3 vie compensato, con eccedenza a scarico, flangiabile su motori Char-Lynn 2000  
 Three way, pressure compensated flow regulator, with exceeding flow to tank, flangeable on Char-Lynn 2000 motors

Rev.01-2010/02

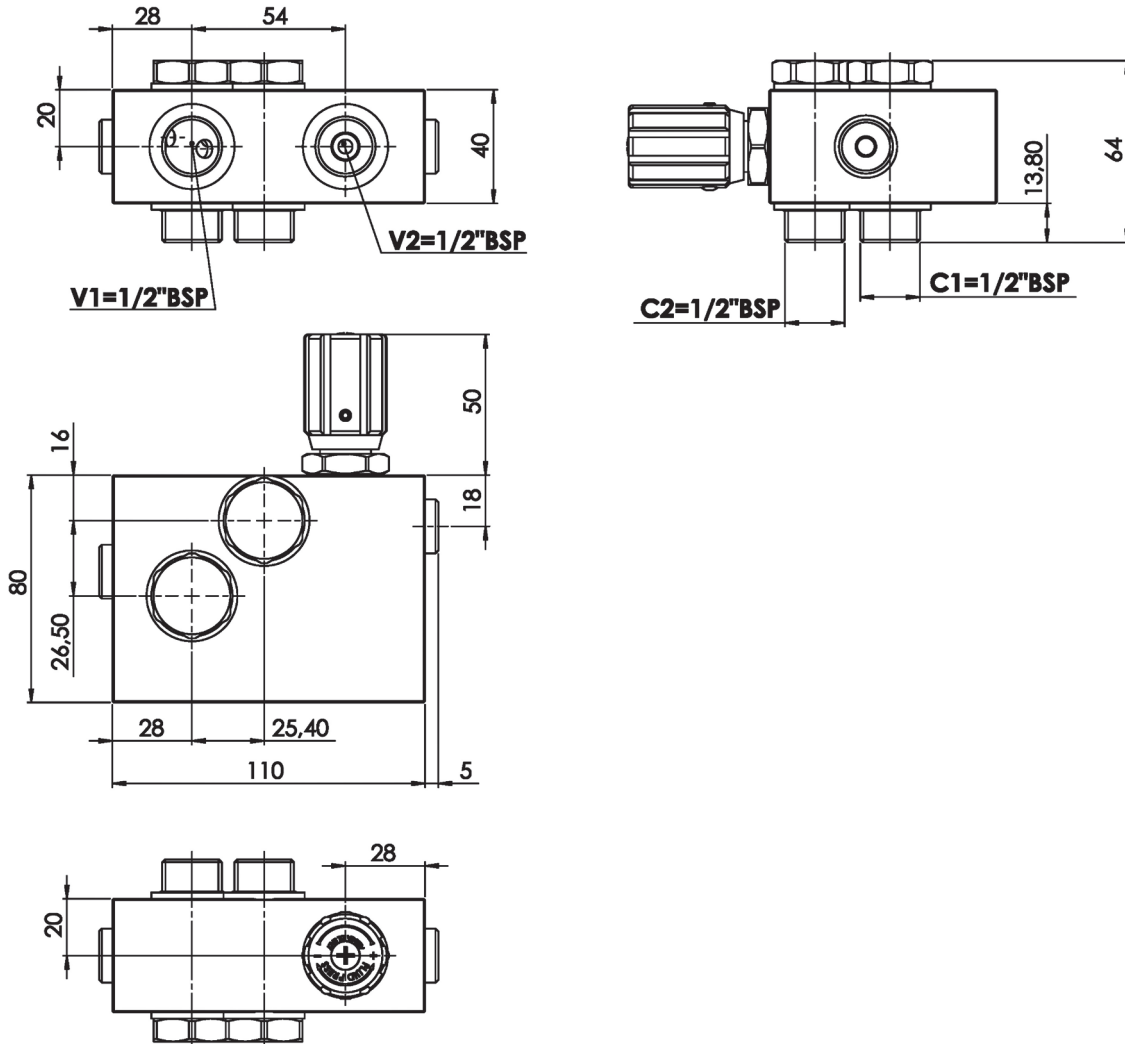

**ESEMPIO DI ORDINAZIONE - ORDERING CODE EXAMPLE**

**F P R F** **5 0** **D V** **E 6** **R** **1 / 2** **S**

Materiale corpo - body material  
 Omettere se alluminio \*  
 Omit if aluminum  
 S = acciaio - steel